

Automatic Fire Sprinkler Systems



3101-310 Poplarwood Court - Raleigh, NC 27604

Ph: 919-212-2722 Fax: 919-212-2720

www.regionalfirenc.info

Fire Alarm Product Data

For:

Krigen Pharmaceuticals

Lillington, NC 27546

ES-50X

Intelligent Addressable FACP with Communicator



Addressable Fire Alarm Control Panels

General

The **ES-50X** is the latest intelligent addressable fire alarm control panel (FACP) from Fire•Lite Alarms and is a direct replacement for the MS-9050UD/LS. The ES-50X comes with a pre-installed communicator and supports up to 50 addressable devices in any combination of detectors or modules. With an extensive list of powerful features, the ES-50X programs just like Fire•Lite's other addressable panels, yet fits into applications previously served only by conventional panels.

The pre-installed IPOTS-COM is a dual technology (POTS and IP) communicator. The POTS transmits system status (alarms, troubles, AC loss, etc.) to a Central Station via the public switched telephone network. The IP communicator's internet monitoring capability sends alarm signals over the Internet saving the monthly cost of two dedicated business telephone lines. Although not required, the secondary telephone line may be retained providing backup communication over the public switched telephone line. Optional cellular reporting is available using the CELL-MOD or CELL-CAB-FL.

Remote and local programming of the control panel is possible using the FS-Tools Upload/Download utility. Programming databases can be uploaded/downloaded via the panel's USB port (and USB cable) or via an ethernet connection using the IPOTS-COM communicator. The USB port also allows for the download or upload of the entire program, history file, walk-test data, current status and system voltages by means of a USB flash drive.

The power supply and all electronics are contained on a circuit board supported on a new quick install chassis and housed in a metal cabinet. Available accessories include local and remote upload/download software, remote annunciators, and reverse polarity/city box transmitter (4XTMF).

Features

- Listed to UL Standard 864, 10th edition
- Pre-installed IPOTS-COM Ethernet IP and POTS (Plain Old Telephone Service) Central Station Communicator
- Optional CELL-MOD or CELL-CAB-FL GSM Central Station Communicator over AlarmNet®
- Compatible with SWIFT® wireless devices
- Auto-programming (learn mode) reduces installation time. Reports two devices set to the same address
- Two independently programmable, built-in Style Z (Class A) or Style Y (Class B) NAC circuits
- Selectable strobe synchronization for System Sensor, Wheelock, and Gentex devices
- Notification Appliance Circuit End of Line resistor matching
- Four programmable function keys for ease of maintenance
- Two programmable relays and one fixed trouble relay
- Built-in Programmer
- Integral 80-character LCD display with backlighting
- Real-time clock/calendar with automatic daylight savings control
- History file with 1,000 event capacity
- Addressable sounder base
- Multi-criteria detector (smoke, heat, CO) with programmable response
- Control module delay timer
- Automatic detector sensitivity testing (NFPA 72 compliant)
- Automatic device type-code verification
- Point trouble identification
- Waterflow selection per module point
- Alarm verification selection per detector point



- Maintenance alert warns when smoke detector dust accumulation is excessive
- One-person audible or silent walktest with walktest log & printout
- System alarm verification selection per detector point
- PAS (Positive Alarm Sequence) and Pre-signal per point (NFPA 72 compliant)
- Up to 16 ANN-BUS annunciators- 8 per each ANN-Bus
- Remote Acknowledge, Alarm Silence, Reset and Drill via addressable modules or remote annunciator
- Upload/Download of program and data via USB with optional FS-Tools Programming Utility

SLC COMMUNICATION LOOP

- Supports LiteSpeed™ and CLIP protocols
- SLC operates up to 10,000 ft. (3,000 m) in LiteSpeed mode with twisted, unshielded wire
- Single addressable SLC loop which meets NFPA Class B and Class A requirements
- 50 addressable device capacity (any combination of addressable detectors and modules)
- Compatible with Fire•Lite's addressable devices (refer to the *SLC Wiring Manual*)

NOTIFICATION APPLIANCE CIRCUITS (NACS)

- Two independently programmable output circuits. Circuits can be configured for the following outputs:
 - **Style Y** (Class B)
 - **Style Z** (Class A)
 - Silence Inhibit and Autosilence timer options
 - Continuous, March Time, Temporal, or California code for main circuit board NACs with two-stage capability
 - Selectable strobe synchronization per NAC
 - 2.5 A special application, 250mA regulated, total power for NACs
- NOTE:** Maximum or total 24VDC system power shared between all NAC circuits and the ANN-BUS is 2.7 A

PROGRAMMING AND SOFTWARE

- Autoprogramming (learn mode) reduces installation time

- Custom English labels (per point) may be manually entered or selected from an internal library file
- Two programmable Form-C relay outputs
- 50 software zones
- Continuous fire protection during online programming
- Program Check automatically catches common errors not linked to any zone or input point
- **OFFLINE PROGRAMMING:** Create the entire program in your office using FS-Tools, a Windows®-based software package, and upload/download system programming locally. Offline programming requires an ethernet connection. FS-Tools is available on www.firelite.com.

User interface

LED INDICATORS

- Fire Alarm (red)
- CO Alarm (red)
- AC Power (green)
- Supervisory (yellow)
- Trouble (yellow)
- Ground fault (yellow)
- Battery fault (yellow)
- Disabled (yellow)
- Maintenance (yellow)
- Communication (yellow)
- Alarm Silenced (yellow)
- F1-F4 Programmable Function Keys (yellow)

KEYPAD

- 16 key alpha-numeric pad
- Acknowledge
- Alarm Silence
- Drill (Manual Evacuate)
- Four (4) programmable function keys
- Reset (lamp test)

Product Line Information

ES-50X: Addressable Fire Alarm Control Panel with one SLC loop. Includes main circuit board with display, pre-installed IPOTS-COM communicator, chassis with transformer, backbox with door, plastic bag containing screws, cables, key, etc. (For ES-50XC, refer to DF-60954.)

FS-Tools: Programming software for Windows®-based PC computer. Available for download at www.firelite.com.

CELL-CAB-FL/CELL-MOD: Optional GSM communicators.

IPOTS-COM: Dual technology (POTS and IP) communicator. (replacement board)

DP-ES-R: Optional dress panel for the ES-50X.

TR-CE: Optional trim ring for semi-flush mounting.

BB-2F: Optional cabinet for one or two modules.

BB-6F: Optional cabinet for up to six modules mounted on CHS-6 chassis.

BB-26: Battery backbox, holds up to two 25 AH batteries & CHG-75.

BB-55F: Battery box, houses two 55 AH batteries

CHS-6: Chassis, mounts up to six multi-modules in a BB-6F cabinet.

CHG-75: Battery charger for lead-acid batteries with a rating of 25 to 75 AH.

CHG-120F: Remote battery charging system for lead-acid batteries with a rating of 55 to 120 AH. Requires additional BB-55F for mounting.

BAT Series: Batteries, see data sheet DF-52397.

PRN Series: UL listed compatible event printer. Uses tractor-fed paper.

OPTIONAL MODULES

4XTMF Reverse Polarity Transmitter Module: Provides a supervised output for local energy municipal box transmitter, alarm and trouble. Includes a disable switch and disable trouble LED.

COMPATIBLE ANNUNCIATORS

ANN-80: Remote, red LCD annunciator mimics the information displayed on the FACP LCD display. Recommended wire type is unshielded.

ANN-100: Remote LCD annunciator mimics the information displayed on the FACP LCD display. Recommended wire type is unshielded. For use in FM applications only.

ANN-I/O: LED Driver Module provides connections to a user supplied graphic annunciator. (See DF-52430.)

ANN-LED: Annunciator Module provides three LEDs for each zone: Alarm, Trouble, and Supervisory. Ships with red enclosure. (See DF-60241.)

ANN-RLED: Provides alarm (red) indicators for up to 30 input zones or addressable points. (See DF-60241.)

ANN-RLY: Relay Module provides 10 programmable Form-C relays. Can be mounted inside the cabinet. (See DF-52431.)

ANN-S/PG: Serial/Parallel Printer Gateway module provides a connection for a serial or parallel printer. (See DF-52429.)

ADDRESSABLE DEVICES

All feature a polling LED and rotary switches for addressing.

SD365: Addressable low-profile photoelectric smoke detector. LiteSpeed only.

SD365-IV: Addressable low-profile photoelectric smoke detector. Ivory. LiteSpeed and CLIP mode.

SD365T: Addressable low-profile photoelectric smoke detector with thermal sensor. LiteSpeed only.

SD365T-IV: Addressable low-profile photoelectric smoke detector with thermal sensor. Ivory. LiteSpeed and CLIP mode.

SD365R: Remote test capable addressable photoelectric smoke detector for use with DNR(W) duct detector housing. LiteSpeed only.

SD365R-IV: Remote test capable addressable photoelectric smoke detector for use with DNR(W) duct detector housing. Ivory. LiteSpeed and CLIP mode.

H365: Low-profile 135°F fixed thermal sensor. LiteSpeed only.

H365-IV: Low-profile 135°F fixed thermal sensor. Ivory. LiteSpeed and CLIP mode.

H365R: Low-profile, intelligent, rate-of-rise thermal sensor. LiteSpeed only.

H365R-IV: Low-profile, intelligent, rate-of-rise thermal sensor. Ivory. LiteSpeed and CLIP mode.

H365HT: Low-profile intelligent 190°F/88°C fixed thermal sensor. LiteSpeed only.

H365HT-IV: Low-profile intelligent 190°F/88°C fixed thermal sensor. Ivory. LiteSpeed and CLIP mode.

Legacy Devices

SD355: Addressable low-profile photoelectric smoke detector.

SD355T: Addressable low-profile photoelectric smoke detector with thermal sensor.

SD355R: Remote test capable addressable photoelectric smoke detector for use with DNR(W) duct detector housing.

SD355CO: Addressable, low-profile device that provides fire, heat, and carbon monoxide (CO) detection.

H355: Fast-response, low-profile heat detector.

H355R: Fast-response, low-profile heat detector with rate-of-rise option.

H355HT: Fast-response, low-profile heat detector that activates at 190°F/88°C.

AD355: Low-profile, intelligent, "Adapt" multi-sensor detector (B350LP base included).

B200S: Programmable, addressable sounder base

B200SR: Addressable sounder base.

BEAM355: Intelligent beam smoke detector.

BEAM355S: Intelligent beam smoke detector with integral sensitivity test.

D355PL: InnovairFlex low-flow non-relay duct-detector housing; includes SD355R.

DNR: InnovairFlex low-flow non-relay duct-detector housing. (Order SD355R/SD365R separately.)

DNRW: InnovairFlex low-flow non-relay duct-detector housing, with NEMA-4 rating. Watertight. (Order SD355R/SD365R separately.)

Addressable Modules

MMF-300: Addressable Monitor Module for one zone of normally-open dry-contact initiating devices. Mounts in standard 4.0" (10.16 cm.) box. Includes plastic cover plate and end-of-line resistor. Module may be configured for either a Style B (Class B) or Style D (Class A) IDC.

MDF-300: Dual Monitor Module. Same as MMF-300 except it provides two Style B (Class B) only IDCs.

MMF-301: Miniature version of MMF-300. Excludes LED and Style D option. Connects with wire pigtailed. May mount in device backbox.

MMF-302: Similar to MMF-300. Addressable Monitor Module for one zone of conventional two-wire detectors. Requires resettable 24 VDC power. Refer to the *Device Compatibility Document* for listed compatible devices and quantity limitation.

CMF-300: Addressable Control Module for one Style Y/Z (Class B/A) zone of supervised polarized Notification Appliances. Mounts directly to a 4.0" (10.16 cm.) electrical box. NAC option requires external 24 VDC to power notification appliances.

CRF-300: Addressable relay module containing two isolated sets of Form-C contacts, which operate as a DPDT switch. Mounts directly to a 4.0" (10.16 cm.) box, surface mount using the SMB500.

BG-12LX: Addressable manual pull station with interface module mounted inside.

I300: This module isolates the SLC loop from short circuit conditions (required for Style 6 or 7 operation).

ISO-6: Six-fault isolator module. Mount one or two modules in a BB-2F cabinet (optional). Mount up to six modules on a CHS-6 chassis in a BB-6F cabinet.

SMB500: Used to mount all modules except MMF-301 and M301.

MMF-300-10: Ten-input monitor module. Mount one or two modules in a BB-2F cabinet (optional). Mount up to six modules on a CHS-6 chassis in a BB-6F cabinet.

MMF-302-6: Six-zone interface module. Mount one or two modules in a BB-2F cabinet (optional). Mount up to six modules on a CHS-6 chassis in a BB-6F cabinet.

CMF-300-6: Six-circuit supervised control module. Mount one or two modules in a BB-2F cabinet (optional). Mount up to six modules on a CHS-6 chassis in a BB-6F cabinet.

CRF-300-6: Six-relay control module (Form-C relays). Mount one or two modules in a BB-2F cabinet (optional). Mount up to six modules on a CHS-6 chassis in a BB-6F cabinet.

SWIFT Wireless Devices

W-GATE: LiteSpeed Wireless Gateway

W-SD355: LiteSpeed intelligent, wireless photo detector.

W-H355R: LiteSpeed intelligent wireless rate of rise (135°) heat detector.

W-SD355T: intelligent wireless photo/heat detector.

W-H355: LiteSpeed intelligent wireless fixed-temperature (135°) heat detector.

W-MMF: LiteSpeed Intelligent wireless monitor module.

W-CRF: LiteSpeed Intelligent wireless relay module.

W-BG12LX: LiteSpeed Intelligent wireless pull station.

WAV-RL, WAV-WL, WAV-CRL, WAV-CWL: LiteSpeed Intelligent AV bases.

W-USB: Wireless USB radio/antenna dongle that plugs into the USB port of a PC running SWIFT Tools.

SWIFT Tools: Programming and diagnostic utility for the Wireless Gateway and devices. Available for download from firelite.com.

NOTE: For more information on Compatible Addressable Devices for use with the ES-50X, see the following data sheets (document numbers): SD365 Series (DF-61010), H365 Series (DF-61011), AD355 (DF-52386), BG-12LX (DF-52013), CMF-300-6 (DF-52365), CRF-300-6 (DF-52374), CMF/CRF Series (DF-52130), CP355 (DF-52383), H355 Series (DF-52385), I300 (DF-52389), ISO-6 (DF-60485), MMF-300 Series/MDF-300 (DF-52121), MMF-300-10 (DF-52347), MMF-302-6 (DF-52356), SD355/SD355T (DF-52384), and SLC Wiring Manual (51309).

NOTE: Legacy 300 Series detection devices such as the CP300/CP350, SD300(T)/SD350(T) and older modules such as the M300, M301, M302, C304, and BG-10LX are not compatible with LiteSpeed polling. If the SLC contains one of these devices, polling must be set for standard CLIP protocol. Please consult factory for further information on previous 300 Series devices.

ADDRESSABLE DEVICE ACCESSORIES

End-of-Line Resistor Assembly (R-47K and R-3.9K): The 47k ohm assembly supervises the MMF-300, MDF-300, MMF-301, and CMF-300 module circuits. The 3.9k ohm assembly supervises the MMF-302 module circuit. These resistors are included with each module.

Power Supervision Relay: Supervises the power to 4-wire smoke detectors and notification appliances.

Wiring Requirements

While shielded wire is not required, it is recommended that all SLC wiring be twisted-pair to minimize the effects of electrical interference. Refer to the panel manual for wiring details.

SYSTEM SPECIFICATIONS

System Capacity

- Intelligent Signaling Line Circuits..... 1
- Addressable device capacity..... 50
- Programmable software zones..... 50
- Annunciators..... 16

Electrical Specifications

AC Power: Operates in either 120 or 240 VAC, 50/60 Hz, 3.25 A, auto-sensing- no switch required. Wire size: minimum 14 AWG (2.00 mm²) with 600 V insulation. Nonpower-limited, supervised.

Battery: Two 12 V 18 AH lead-acid batteries. Battery Charger Capacity: 7-18 AH (ES-50X cabinet holds maximum of two 18 AH batteries.)

Communication Loop: Supervised and power-limited.

Notification Appliance Circuits: Terminal Block provides connections for two NACs, Style Y (Class B) or Style Z (Class A). Special Application power. Power-limited, supervised circuitry. Maximum signaling current per circuit: 2.5 amps special application, 250mA regulated. End-of-Line Resistor: 4.7k ohm, ½ watt (P/N 71252 UL listed) for Style Y (Class B) NAC; system capable of 1.9 kΩ - 22 kΩ ELR range. Refer to the *Fire•Lite Device Compatibility Document* for listed compatible devices.

Two Programmable Relays and One Fixed Trouble Relay: Contact rating: 2.0 A @ 30 VDC (resistive), 0.5 A @ 30 VAC (resistive). Form-C relays, non-power-limited, non-supervised.

Cabinet Specifications

Door: 19.26" (48.92 cm.) high x 16.82" (42.73 cm.) wide x 0.72" (1.82 cm.) deep. **Backbox:** 19.00" (48.26 cm.) high x 16.65" (42.29 cm.) wide x 5.25" (13.34 cm.) deep. **Trim Ring (TR-CE):** 22.00" (55.88 cm.) high x 19.65" (49.91 cm.) wide.

Shipping Specifications

Weight: 26.9 lbs. (12.20 kg.) **Dimensions:** 20.00" (50.80 cm.) high x 22.5" (57.15 cm.) wide x 8.5" (21.59 cm.) deep.

Temperature and Humidity Ranges

This system meets NFPA requirements for operation at 0 – 49°C/32 – 120°F and at a relative humidity 93% ± 2% RH (noncondensing) at 32°C ± 2°C (90°F ± 3°F). However, the useful life of the system's standby batteries and the electronic components may be adversely affected by extreme temperature ranges and humidity. Therefore, it is recommended that this system and its peripherals be installed in an environment with a normal room temperature of 15 – 27°C/60 – 80°F.

NFPA Standards

The ES-50X complies with the following NFPA 72 Fire Alarm Systems requirements:

- **LOCAL** (Automatic, Manual, Waterflow and Sprinkler Supervisory).
- **AUXILIARY** (Automatic, Manual and Waterflow) (requires 4XTMF).
- **REMOTE STATION** (Automatic, Manual and Waterflow) (Where a DACT is not accepted, the alarm, trouble and supervisory relays may be connected to UL 864 listed transmitters. For reverse polarity signaling of alarm and trouble, 4XTMF is required.)
- **PROPRIETARY** (Automatic, Manual and Waterflow).
- **CENTRAL STATION** (Automatic, Manual and Waterflow, and Sprinkler Supervised).
- **OT, PSDN** (Other Technologies, Packet-switched Data Network)
- **IBC 2012, IBC 2009, IBC 2006, IBC 2003, IBC 2000** (Seismic).
- **CBC 2007** (Seismic)

Agency Listings and Approvals

The listings and approvals below apply to the basic ES-50X control panel. In some cases, certain modules may not be listed by certain approval agencies, or listing may be in process. Consult factory for latest listing status.

- **UL:** S624
- **FM approved**
- **CSFM:** 7165-0075:0500
- **FDNY:** COA #6261

NOTE: See DF-60954 for ULC-listed model.

AlarmNet®, Fire-Lite® Alarms, SWIFT®, and System Sensor® are registered trademarks of Honeywell International Inc. Microsoft® and Windows® are registered trademarks of the Microsoft Corporation.
©2018 by Honeywell International Inc. All rights reserved. Unauthorized use of this document is strictly prohibited.



This document is not intended to be used for installation purposes.
We try to keep our product information up-to-date and accurate.
We cannot cover all specific applications or anticipate all requirements.
All specifications are subject to change without notice.

For more information, contact Fire•Lite Alarms. Phone: (800) 627-3473, FAX: (877) 699-4105.
www.firelite.com

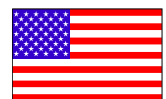

Country of Origin: USA

SD365 Series

Addressable Photoelectric Smoke Detectors



Addressable Devices

The Fire•Lite® Alarms SD365(A), SD365R(A), and SD365HT(A) intelligent plug-in smoke detectors are designed for both performance and aesthetics, and are direct replacements for the SD355 Series. A new modern, sleek, contemporary design and enhanced optical sensing chamber is engineered to sense smoke produced by a wide range of combustion sources in accordance with more stringent code standards.

Exclusively for use with Fire•Lite's addressable fire alarm control panels, the SD365(A) Series point ID capability allows each detector's address to be set with rotary, decimal address switches, providing exact detector location for emergency personnel to quickly locate a fire during its early stages, potentially saving precious rescue time while also reducing property damage. Two LEDs on each sensor light to provide a local, visible sensor indication.

The SD365(A) Series also offers 135°F (57°C) fixed temperature thermal sensing on the SD365T(A) and a remote test capable detector on the SD365R(A) for use with DNR(A)/DNRW duct smoke detector housings.

Features

SLC LOOP:

- Two-wire SLC loop connection
- Unit uses base for wiring
- Compatible with LiteSpeed™ and CLIP protocol systems
- Stable communication technique with noise immunity

ADDRESSING:

- Addressable by device
- Rotary, decimal addressing
(Refer to the *Fire•Lite panel manuals* for device capacity.)

ARCHITECTURE:

- Sleek, low-profile, stylish design
- Unique single-source design to respond quickly and dependably to a broad range of fires
- Integral communications and built-in device-type identification
- Built-in tamper resistant feature
- Remote test feature from the panel
- Walk test with address display (an address on 121 will blink the detector LED: 12-[pause]-1 (*LiteSpeed systems only*))
- Built-in functional test switch activated by external magnet
- Removable cover and insect-resistant screen for simple field cleaning
- Expanded color options

OPERATION:

- Designed to meet UL 268 7th Edition
- Factory preset at 1.5% nominal sensitivity for panel alarm threshold level
- LED "blinks" when the unit is polled (communicating with the fire panel) and latches in alarm.
- Low standby current

MECHANICALS:

- Sealed against back pressure
- SEMS screws for wiring of the separate base
- Designed for direct-surface or electrical-box mounting



- Plugs into separate base for ease of installation and maintenance
- Separate base allows interchange of photoelectric, ionization and thermal sensors

OPTIONS:

- Optional relay, isolator, and sounder bases

Installation

SD365 Series plug-in intelligent smoke detectors use a detachable base to simplify installation, service and maintenance. Installation instructions are shipped with each detector.

Mount detector base (all base types) on an electrical backbox which is at least 1.5" (3.81 cm) deep. For a chart of compatible junction boxes, see *DF-60059*.

NOTE: Because of the inherent supervision provided by the SLC loop, end-of-line resistors are not required. Wiring "T-taps" or branches are permitted for Style 4 (Class "B") wiring only.

When using relay or sounder bases, consult the *I300(A) installation sheet I56-3626* for device limitations between isolator modules and isolator bases.

Construction

These detectors are constructed of fire-resistant plastic. The SD365 Series plug-in intelligent smoke detectors are designed to commercial standards and offer an attractive appearance.

Operation

Each SD365 Series detector uses one of the panel's addresses (total limit is panel dependent) on the Fire•Lite Signaling Line Circuit (SLC). It responds to regular polls from the control panel and reports its type and the status. If it receives a test command from the panel (or a local magnet test), it stimulates its electronics and reports an alarm. It blinks its LEDs when polled and turns the LEDs on when commanded by the panel. The SD365 Series offers features and performance that represent the latest in smoke detector technology.

Detector Sensitivity Test

Each detector can have its sensitivity tested (required per NFPA 72, Chapter 14 on *Inspection, Testing and Maintenance*) when installed/connected to an Fire•Lite addressable fire alarm control panel. The results of the sensitivity test can be printed for record keeping.

Product Line Information

NOTE: “-IV” suffix indicates CLIP and LiteSpeed device.

NOTE: “A” suffix indicates Canadian version.

SD365: White, low-profile intelligent photoelectric sensor, LiteSpeed only

SD365A: Same as SD365 but with ULC listing

SD365-IV: Ivory, low-profile intelligent photoelectric sensor

SD365A-IV: Same as SD365-IV but with ULC listing

SD365T: White, same as **SD365** but includes a built-in 135°F (57°C) fixed-temperature thermal device, LiteSpeed only

SD365TA: Same as SD365T but with ULC listing

SD365T-IV: Ivory, same as SD365T but includes a built-in 135°F (57°C) fixed-temperature thermal device

SD365TA-IV: Same as SD365T-IV but with ULC listing

SD365R: White, low-profile intelligent photoelectric sensor, remote test capable, for use with DNR/DNRW, LiteSpeed only

SD365RA: Same as SD365R but with ULC listing, for use with DNRA

SD365R-IV: Ivory, low-profile intelligent photoelectric sensor, remote test capable, for use with DNR/DNRW

SD365RA-IV: Same as SD365R-IV but with ULC listing, for use with DNRA

INTELLIGENT BASES

NOTE: For details on intelligent bases, see DF-60059.

B300-6: White, 6” base, standard flanged low-profile mounting base (CSFM: 7300-1653:0109)

B300-6-IV: Ivory, 6” base, standard flanged low-profile mounting base (CSFM: 7300-1653:0109)

B300A-6: Same as B300-6, ULC listed

B300A-6-IV: Ivory, 6” standard flanged low-profile mounting base, ULC listed

B300-6-BP: Bulk pack of B300-6, package contains 10

B501-WHITE: White, 4” standard European flangeless mounting base. UL/ULC listed (CSFM: 7300-1653:0109)

B501-BL: Black, 4” standard European flangeless mounting base. UL/ULC listed (CSFM: 7300-1653:0109)

B501-IV: Ivory color, 4” standard European flangeless mounting base. UL/ULC listed (CSFM: 7300-1653:0109)

B501-WHITE-BP: Bulk pack of B501-WHITE contains 10

B224RB-WH: White, relay base (CSFM: 7300-1653:0216)

B224RB-IV: Ivory, relay base (CSFM: 7300-1653:0216)

B224RBA-WH: White, relay base, ULC listing

B224RBA-IV: Ivory, relay base, ULC listing

B224BI-WH: White, isolator detector base (CSFM: 7300-1653:0216)

B224BI-IV: Ivory isolator detector base (CSFM: 7300-1653:0216)

B224BIA-WH: White, isolator detector base, ULC listing

B224BIA-IV: Ivory isolator detector base, ULC listing

B200S-WH: White, Intelligent addressable sounder base capable of producing sound output in high or low volume with ANSI Temporal 3, ANSI Temporal 4, continuous tone, marching tone, and custom tone. Uses FlashScan protocol. (CSFM: 7300-1653:0213)

B200S-IV: Ivory, Intelligent addressable sounder base capable of producing sound output in high or low volume with ANSI Temporal 3, ANSI Temporal 4, continuous tone, marching tone, and custom tone. Uses FlashScan protocol. (CSFM: 7300-1653:0213)

B200SA-WH: Same as B200S-WH, ULC listing

B200SA-IV: Same as B200S-IV, ULC listing

B200SCOA-WH: White, Intelligent, programmable sounder base in English/French (required in Canada for ULC applications with CO Series detector applications)

B200SCOA-IV: Ivory Intelligent, programmable sounder base in English/French (required in Canada for ULC applications with CO Series detector applications, ULC listing)

B200S-LF-WH: White, Low Frequency Intelligent, programmable sounder base. Produces a fundamental frequency of 520 Hz +/- 10% with a square wave or its equivalent; designed to meet the NFPA 72 sleeping space requirement. (CSFM: 7300-1653:0238)

B200S-LF-IV: Ivory, Low Frequency Intelligent, programmable sounder base. Produces a fundamental frequency of 520 Hz +/- 10% with a square wave or its equivalent; designed to meet the NFPA 72 sleeping space requirement. (CSFM: 7300-1653:0238)

B200SR-WH: White, Intelligent sounder base capable of producing sound output with ANSI Temporal 3 or continuous tone. Intended for retrofit applications. (CSFM: 7300-1653:0213)

B200SR-IV: Ivory, Intelligent sounder base capable of producing sound output with ANSI Temporal 3 or continuous tone. Intended for retrofit applications. (CSFM: 7300-1653:0213)

B200SRA-WH: Same as B200SR-WH with, ULC listing

B200SRA-IV: Same as B200SR-IV in Ivory color, ULC listing

B200SR-LF-WH: White, Low Frequency Intelligent, programmable sounder base. Produces a fundamental frequency of 520 Hz +/- 10% with a square wave or its equivalent; designed to meet the NFPA 72 sleeping space requirement. Intended for retrofit applications. (CSFM: 7300-1653:0238)

B200SR-LF-IV: Ivory, Low Frequency Intelligent, programmable sounder base. Produces a fundamental frequency of 520 Hz +/- 10% with a square wave or its equivalent; designed to meet the NFPA 72 sleeping space requirement. Intended for retrofit applications. (CSFM: 7300-1653:0238)

MOUNTING KITS AND ACCESSORIES

TR300: White, replacement flange for B210LP(A) base

TR300-IV: Ivory, replacement flange for B210LP(A) base

RA100Z(A): Remote LED annunciator. 3-32 VDC. Mounts to a U.S. single-gang electrical box. For use with B501(A) and B300-6(A).

M02-04-00: Test magnet

M02-09-00: Test magnet with telescoping handle

CK300: Color Kit (includes cover and trim ring), white, 10-pack

CK300-IV: Color Kit (includes cover and trim ring), ivory, 10-pack

CK300-BL: Color Kit (includes cover and trim ring), black, 10-pack

SYSTEM SPECIFICATIONS

Sensitivity:

- UL Applications: 0.5% to 4.0% per foot obscuration.
- ULC Applications: 0.5% to 3.5% per foot obscuration

Size: 2.0" (5.3 cm) high; base determines diameter

- **B300-6:** 6.1" (15.6 cm) diameter
- **B501:** 4" (10.2 cm) diameter

For a complete list of detector bases see DF-60983

Shipping weight: 3.4 oz. (95 g)

Operating temperature range:

- SD365: 32°F to 122°F (0°C to 50°C)
- SD365T Series: 32°F to 100°F (0°C to 38°C)
- SD365R Series installed in a DNR/DNRW, -4°F to 158°F (-20°C to 70°C)

UL/ULC Listed Velocity Range: 0-4000 ft/min. (1219.2 m/min.), suitable for installation in ducts

Relative humidity: 10% – 93% non-condensing

Thermal ratings: fixed-temperature set point 135°F (57°C), rate-of-rise detection 15°F (8.3°C) per minute, high temperature heat 190°F (88°C)

ELECTRICAL SPECIFICATIONS

Voltage range: 15 - 32 volts DC peak

Standby current (max. avg.): 200µA @ 24 VDC (one communication every 5 seconds with LED enabled)

Max current: 4.5 mA @ 24 VDC ("ON")

DETECTOR SPACING AND APPLICATIONS

Fire•Lite recommends spacing detectors in compliance with NFPA 72. In low airflow applications with smooth ceiling, space detectors 30 feet (9.1m). For specific information regarding detector spacing, placement, and special applications refer to NFPA 72. A *System Smoke Detector Application Guide*, document A05-1003, is available at www.systemsensor.com.

Listings and Approvals

Listings and approvals below apply to the SD365 Series detectors. In some cases, certain modules may not be listed by certain approval agencies, or listing may be in process. Consult factory for latest listing status.

- UL/ULC Listing: S1059
- FM Approved
- CSFM: 7272-0075:0502

LiteSpeed™ is a trademark, and Fire•Lite® Alarms and System Sensor® are registered trademarks of Honeywell International Inc.
©2019 by Honeywell International Inc. All rights reserved. Unauthorized use of this document is strictly prohibited.



This document is not intended to be used for installation purposes.
We try to keep our product information up-to-date and accurate.
We cannot cover all specific applications or anticipate all requirements.
All specifications are subject to change without notice.

For more information, contact Fire•Lite Alarms. Phone: (800) 627-3473, FAX:(877) 699-4105.
www.firelite.com

Country of Origin: Mexico

MMF-300(A) Series, MDF-300

Addressable Monitor Modules



Addressable Devices

General

Four different monitor modules are available for Fire•Lite's intelligent control panels to suit a variety of applications. Monitor modules are used to supervise a circuit of dry-contact input devices, such as conventional heat detectors and pull stations, or monitor and power a circuit of two-wire smoke detectors (MMF-302(A)).

MMF-300(A) is a standard-sized module (typically mounts to a 4" [10.16 cm] square box) that supervises either a Style D (Class A) or Style B (Class B) circuit of dry-contact input devices.

MMF-301(A) is a miniature monitor module a mere 1.3" (3.302 cm) H x 2.75" (6.985 cm) W x 0.65" (1.651 cm) D that supervises a Style B (Class B) circuit of dry-contact input devices. Its compact design allows the MMF-301(A) to be mounted in a single-gang box behind the device it monitors.

MMF-302(A) is a standard-sized module used to monitor and supervise compatible two-wire, 24 volt, smoke detectors on a Style D (Class A) or Style B (Class B) circuit.

MDF-300(A) is a standard-sized dual monitor module used to monitor and supervise two independent two-wire Style B (Class B) dry-contact initiating device circuits (IDCs) at two separate, consecutive addresses in intelligent, two-wire systems.

LiteSpeed™ is a communication protocol developed by Fire•Lite Engineering that greatly increases the speed of communication between analog intelligent devices. Intelligent devices communicate in a grouped fashion. If one of the devices within the group has new information, the panel CPU stops the group poll and concentrates on single points. The net effect is response speed greater than five times that of other communication protocols.

MMF-300(A) Monitor Module

- Built-in type identification automatically identifies this device as a monitor module to the control panel.
- Powered directly by two-wire SLC loop. No additional power required.
- High noise (EMF/RFI) immunity.
- SEMS screws with clamping plates for ease of wiring.
- Direct-dial entry of address: 01 – 159 on MS-9600 series panels, 01 – 99 on other compatible systems.
- LED flashes during normal operation and latches on steady to indicate alarm.

The MMF-300(A) Monitor Module is intended for use in intelligent, two-wire systems, where the individual address of each module is selected using the built-in rotary switches. It provides either a two-wire or four-wire fault-tolerant Initiating Device Circuit (IDC) for normally-open-contact fire alarm and supervisory devices. The module has a panel-controlled LED indicator. The MMF-300(A) can be used to replace M300(A) modules in existing systems.

MMF-300(A) APPLICATIONS

Use to monitor a zone of four-wire smoke detectors, manual fire alarm pull stations, waterflow devices, or other normally-open dry-contact alarm activation devices. May also be used to monitor normally-open supervisory devices with special

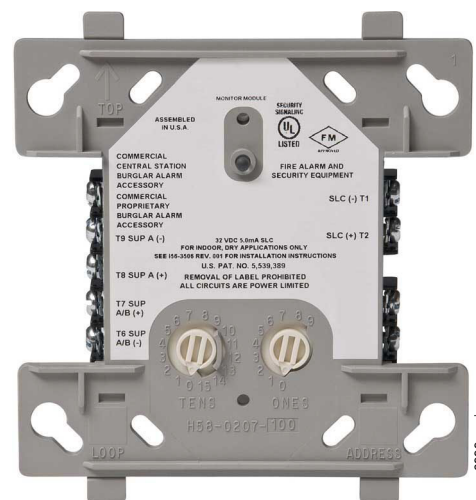

MMF-300(A) (Type H)

supervisory indication at the control panel. Monitored circuit may be wired as an NFPA Style B (Class B) or Style D (Class A) Initiating Device Circuit. A 47K Ohm End-of-Line Resistor (provided) terminates the Style B circuit. No resistor is required for supervision of the Style D circuit.

MMF-300(A) OPERATION

Each MMF-300(A) uses one of the available module addresses on an SLC loop. It responds to regular polls from the control panel and reports its type and the status (open/normal/short) of its Initiating Device Circuit (IDC). A flashing LED indicates that the module is in communication with the control panel. The LED latches steady on alarm (subject to current limitations on the loop).

MMF-300(A) SPECIFICATIONS

Nominal operating voltage: 15 to 32 VDC.

Maximum current draw: 5.0 mA (LED on).

Average operating current: 375 μ A (LED flashing), 1 communication every 5 seconds, 47k EOL.

Maximum IDC wiring resistance: 1500 Ohms.

Maximum IDC Voltage: 11 Volts.

EOL resistance: 47K Ohms.

Temperature range: 32°F to 120°F (0°C to 49°C).

Humidity range: 10% to 93% noncondensing.

Dimensions: 4.5" (11.43 cm) high x 4" (10.16 cm) wide x 1.25" (3.175 cm) deep. Mounts to a 4" (10.16 cm) square x 2.125" (5.398 cm) deep box.

MMF-301(A) Mini Monitor Module

- Built-in type identification automatically identifies this device as a monitor module to the panel.
- Powered directly by two-wire SLC loop. No additional power required.
- High noise (EMF/RFI) immunity.

- Tinned, stripped leads for ease of wiring.
- Direct-dial entry of address: 01 – 159 on MS-9600 series panels, 01 – 99 on other compatible systems

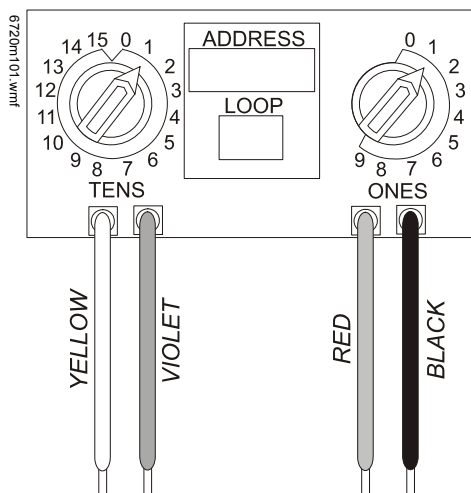

The MMF-301(A) Mini Monitor Module can be installed in a single-gang junction directly behind the monitored unit. Its small size and light weight allow it to be installed without rigid mounting. The MMF-301(A) is intended for use in intelligent, two-wire systems where the individual address of each module is selected using rotary switches. It provides a two-wire initiating device circuit for normally-open-contact fire alarm devices. The MMF-301(A) can be used to replace M301(A) modules in existing systems.

MMF-301(A) APPLICATIONS

Use to monitor a single device or a zone of four-wire smoke detectors, manual fire alarm pull stations, waterflow devices, or other normally-open dry-contact devices. May also be used to monitor normally-open supervisory devices with special supervisory indication at the control panel. Monitored circuit/device is wired as an NFPA Style B (Class B) Initiating Device Circuit. A 47K Ohm End-of-Line Resistor (provided) terminates the circuit.

MMF-301(A) OPERATION

Each MMF-301(A) uses one of the available module addresses on an SLC loop. It responds to regular polls from the control panel and reports its type and the status (open/normal/short) of its Initiating Device Circuit (IDC).

MMF-301(A) SPECIFICATIONS

Nominal operating voltage: 15 to 32 VDC.

Average operating current: 350 μ A, 1 communication every 5 seconds, 47k EOL; 600 μ A Max. (Communicating, IDC Shorted).

Maximum IDC wiring resistance: 1500 Ohms.

Maximum IDC Voltage: 11 Volts.

Maximum IDC Current: 450 μ A.

EOL resistance: 47K Ohms.

Temperature range: 32°F to 120°F (0°C to 49°C).

Humidity range: 10% to 93% noncondensing.

Dimensions: 1.3" (3.302 cm) high x 2.75" (6.985 cm) wide x 0.65" (1.651 cm) deep.

Wire length: 6" (15.24 cm) minimum.

MMF-302(A) Interface Module

- Supports compatible two-wire smoke detectors.

- Supervises IDC wiring and connection of external power source.
- High noise (EMF/RFI) immunity.
- SEMS screws with clamping plates for ease of wiring.
- Direct-dial entry entry of address: 01 – 159 on MS-9600 series panels, 01 – 99 on other compatible systems.
- LED flashes during normal operation.
- LED latches steady to indicate alarm on command from control panel.

The MMF-302(A) Interface Module is intended for use in intelligent, addressable systems, where the individual address of each module is selected using built-in rotary switches. This module allows intelligent panels to interface and monitor two-wire conventional smoke detectors. It transmits the status (normal, open, or alarm) of one full zone of conventional detectors back to the control panel. All two-wire detectors being monitored must be UL compatible with the module. The MMF-302(A) can be used to replace M302(A) modules in existing systems.

MMF-302 (A) APPLICATIONS

Use the MMF-302(A) to monitor a zone of two-wire smoke detectors. The monitored circuit may be wired as an NFPA Style B (Class B) or Style D (Class A) Initiating Device Circuit. A 3.9 K Ohm End-of-Line Resistor (provided) terminates the end of the Style B or D (class B or A) circuit (maximum IDC loop resistance is 25 Ohms). Install ELR across terminals 8 and 9 for Style D application.

MMF-302(A) OPERATION

Each MMF-302(A) uses one of the available module addresses on an SLC loop. It responds to regular polls from the control panel and reports its type and the status (open/normal/short) of its Initiating Device Circuit (IDC). A flashing LED indicates that the module is in communication with the control panel. The LED latches steady on alarm (subject to current limitations on the loop).

MMF-302(A) SPECIFICATIONS

Nominal operating voltage: 15 to 32 VDC.

Maximum current draw: 5.1 mA (LED on).

Maximum IDC wiring resistance: 25 Ohms.

Average operating current: 270 μ A, 1 communication and 1 LED flash every 5 seconds, 3.9k eol.

EOL resistance: 3.9K Ohms.

External supply voltage (between Terminals T10 and T11):

- DC voltage: 24 volts power limited.
- Ripple voltage: 0.1 Vrms maximum.
- Current: 90 mA per module maximum.

Temperature range: 32°F to 120°F (0°C to 49°C).

Humidity range: 10% to 93% noncondensing.

Dimensions: 4.5" (11.43 cm) high x 4" (10.16 cm) wide x 1.25" (3.175 cm) deep. Mounts to a 4" (10.16 cm) square x 2.125" (5.398 cm) deep box.

MDF-300(A) Dual Monitor Module

The MDF-300(A) Dual Monitor Module is intended for use in intelligent, two-wire systems. It provides two independent two-wire initiating device circuits (IDCs) at two separate, consecutive addresses. It is capable of monitoring normally open contact fire alarm and supervisory devices. The module has a single panel-controlled LED.

NOTE: The MDF-300(A) provides two Style B (Class B) IDC circuits ONLY. Style D (Class A) IDC circuits are NOT supported in any application.

MDF-300(A) SPECIFICATIONS

Normal operating voltage range: 15 to 32 VDC.

Maximum current draw: 6.4 mA (LED on).

Average operating current: 750 μ A (LED flashing).

Maximum IDC wiring resistance: 1,500 Ohms.

Maximum IDC Voltage: 11 Volts.

Maximum IDC Current: 240 μ A

EOL resistance: 47K Ohms.

Temperature range: 32° to 120°F (0° to 49°C).

Humidity range: 10% to 93% (non-condensing).

Dimensions: 4.5" (11.43 cm) high x 4" (10.16 cm) wide x 1.25" (3.175 cm) deep. Mounts to a 4" (10.16 cm) square x 2.125" (5.398 cm) deep box.

MDF-300(A) AUTOMATIC ADDRESSING

The MDF-300(A) automatically assigns itself to two addressable points, starting with the original address. For example, if the MDF-300(A) is set to address "26", then it will automatically assign itself to addresses "26" and "27".

NOTE: "Ones" addresses on the MDF-300(A) are 0, 2, 4, 6, or 8 only. Terminals 6 and 7 use the first address, and terminals 8 and 9 use the second address.

CAUTION:

Avoid duplicating addresses on the system.

MDF-300(A): Monitor module, dual, two independent Class B circuits.

SMB500: Optional surface-mount backbox.

NOTE: See installation instructions and refer to the SLC Wiring Manual, PN 51309.

Architects'/Engineers' Specifications

Specifications of these devices and all FireLite products are available from FireLite.

Installation

MMF-300(A), MMF-302(A), and MDF-300(A) modules mount directly to a standard 4" (10.16 cm) square, 2.125" (5.398 cm) deep, electrical box. They may also be mounted to the SMB500 surface-mount box. Mounting hardware and installation instructions are provided with each module. All wiring must conform to applicable local codes, ordinances, and regulations. These modules are intended for power-limited wiring only.

The MMF-301(A) module is intended to be wired and mounted without rigid connections inside a standard electrical box. All wiring must conform to applicable local codes, ordinances, and regulations.

Agency Listings and Approvals

In some cases, certain modules may not be listed by certain approval agencies, or listing may be in process. Consult factory for latest listing status.

- **UL:** S2424.
- **ULC:** S2424.
- **FM Approved.**
- **CSFM:** 7300-0075:0185.
- **MEA:** 72-01-E.

Product Line Information

NOTE: "A" suffix indicates ULC-listed model.

MMF-300(A): Monitor module.

MMF-301(A): Monitor module, miniature.

MMF-302(A): Monitor module, two-wire detectors.

Fire-Lite® is a registered trademark and LiteSpeed™ and FireWatch™ are trademarks of Honeywell International Inc.
©2015 by Honeywell International Inc. All rights reserved. Unauthorized use of this document is strictly prohibited.



This document is not intended to be used for installation purposes.
We try to keep our product information up-to-date and accurate.
We cannot cover all specific applications or anticipate all requirements.
All specifications are subject to change without notice.

For more information, contact Fire•Lite Alarms. Phone: (800) 627-3473, FAX: (877) 699-4105.
www.firelite.com

W-BG12LX & W-BG12LXSP

SWIFT Wireless Pullstations



Intelligent Wireless Devices

The Fire-Lite® SWIFT® addressable pull station is a dual-action, manual pull station with a key-lock reset feature that provides one addressable alarm initiating input. The pull station features similar aesthetic design and durable construction characteristics as the wired counterpart to blend seamlessly throughout the environment. The device communicates to the FACP through the SWIFT mesh network and gateway, and is powered by 4 batteries offering a 2-year, UL listed battery life.

Installation is fast and straightforward by using a mounting plate that can be surface mounted. Once the mounting plate is firmly attached to the wall, the pull station is snapped into place and locked down with 3 screws.

The mechanical operation is simple and easy to use in an emergency with a PUSH IN/PULL DOWN handle that latches in the down position to clearly indicate the station has been operated while the word "ACTIVATED" appears on top of the handle in bright yellow, further indicating the operation of the station.

The wireless pull station meets the Americans with Disabilities Act Accessibility Guidelines' (ADAAG) controls and operating mechanisms guidelines (section 4.1.3[13]) and the Americans with Disabilities Act (ADA) requirement for a 5-pound maximum pull force to activate the pull station and conforms to ANSI/UL Standard 38.

The SWIFT wireless system offers intelligent (addressable) devices which provide secure, reliable communication to the Fire Alarm Control Panel (FACP) across a Class A mesh network. Wireless devices create an opportunity for applications where it is costly (concrete walls/ceilings, buried wires), obtrusive (surface mount conduit), or possibly dangerous (asbestos) to use traditional wired devices. In addition, both wired and wireless devices can be present on the same FACP providing an integrated wired-wireless solution for increased installation potential.

The mesh network within the SWIFT system creates a child-parent relationship between the devices so that each device has two parents providing a second path for communications on every device. If one device can no longer operate for any reason, the rest of the devices can still communicate with each other, directly or through one or more intermediate devices. Once an initial mesh network is formed, mesh restructuring automatically occurs to find the strongest paths possible within the network.

The SWIFT system also engages frequency hopping to prevent system interference whether intentional or accidental. Each device complies with part 15 of the FCC rules meaning operation is subject to the following two conditions: 1) The device may not cause harmful interference and 2) The device must accept any interference received including interference that may cause undesired operation.

Features

- Easy, fast, wireless installation
- Participates in a Class A mesh network
- Built-in tri-color LED, which is visible through the handle of the station, flashes in normal operation and latches steady red when in alarm
- Handle latches in down position and the word "ACTIVATED" appears to clearly indicate the station has been operated
- Maintenance personnel can open station for inspection and address setting without causing an alarm condition
- Standard "code wheel" for setting the SLC address
- For use in commercial applications
- Smooth dual-action design

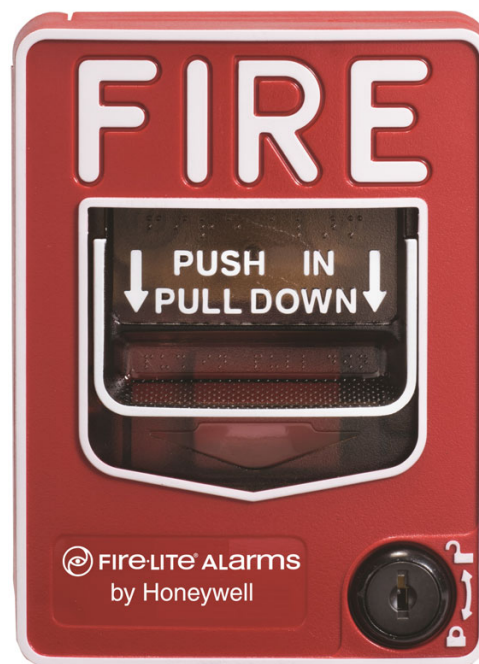

- Meets ADAAG controls and operating mechanisms guidelines (Section 4.1.3[13]); meets ADA requirement for 5lb. maximum activation force.
- Meets UL 38, Standard for Manually Actuated Signaling Boxes
- Highly visible
- Made of durable polycarbonate material
- Attractive shape and textured finish
- Key reset
- Includes Braille text on station handle

Compatible Control Panels

- ES-50X
- ES-200X
- MS-9200UDLS
- MS-9600(UD)LS

Components and Ordering Information

- **W-BG12LX:** Wireless addressable pullstation. Requires (4) CR-123A batteries (included).
- **W-BG12LXSP:** Wireless addressable pullstation. Spanish text. Requires (4) CR-123A batteries (included).
- **W-GATE:** Fire-Lite Wireless SWIFT Gateway - 1 SWIFT Gateway is required for each wireless mesh, and supports up to 48 SWIFT detectors or modules, and one display driver, if required. Connects to the SLC loop of a compatible panel using LiteSpeed protocol. Power may be supplied by the SLC circuit or via an optional 24VDC input.

NOTE: Use of the 24VDC input may be more convenient for service as it allows for powering down a gateway without shutting down an SLC loop.

- **W-DIS-D:** LCD user interface for use with the W-GATE wireless gateway and an ANN-80-W Remote Annunciator. Connects to

the FACP via the ANN-BUS. Both W-DIS-D and ANN-80-W are required to display trouble and supervisory conditions that are specific to the W-GATE and its devices. One W-DIS-D is required for each W-GATE in a system using the MS-9200UDLS or MS-9600(UD)LS.

- **ANN-80-W:** White 80 character LCD annunciator used with the W-DIS-D to display wireless-specific events not displayed on the FACP.
- **W-SD355:** intelligent, wireless photo detector. Ships with B501W base included. Requires (4) CR-123A batteries (included).
- **W-H355R:** intelligent wireless rate of rise (135°) heat detector. Ships with B501W base included. Requires (4) CR-123A batteries (included).
- **W-SD355T:** intelligent wireless photo/heat detector. Ships with B501W base included. Requires (4) CR-123A batteries (included).
- **W-H355:** intelligent wireless fixed-temperature (135°) heat detector. Ships with B501W base included. Requires (4) CR-123A batteries (included).
- **W-MMF:** Wireless monitor module. Used to monitor devices with mechanical contact actuation. Includes a special cover with a built-in tamper magnet. Recommended for installation in a SMB500-WH box (ordered separately) rather than a metal backbox for best performance. Requires (4) CR-123A batteries (included).
- **W-CRF:** Wireless relay module for use with the W-GATE wireless gateway. Includes a special cover with a built-in tamper magnet. Recommended for installation in an SMB500-WH box (ordered separately) rather than a metal backbox for best performance. Requires (4) CR-123A batteries (included).
- **WAV-CRL, WAV-CWL:** SWIFT Wireless Addressable A/V bases. Requires (8) CR-123A batteries (included). Requires a non-compact ceiling System Sensor® L-series notification device (ordered separately).
- **W-SYNC:** Wireless sync module. Requires (4) CR-123A batteries (included).
- **SMB500-WH:** Optional surface-mount backbox.
- **SWIFT Tools:** Programming and diagnostic utility. Free download from www.firelite.com. For installation on a (typically laptop) PC running an approved version of Windows (See Minimum System Requirements for SWIFT Tools). Requires the W-USB radio/antenna dongle for communication with SWIFT Wireless devices.
- **W-USB:** Wireless USB radio/antenna dongle that plugs into the USB port of a PC running SWIFT Tools. The W-USB provides a communication link with SWIFT Wireless devices that are within approximately 20 feet and have not formed a mesh. Alternately, when the devices have formed a mesh, bringing the PC/W-USB within range (20 ft.) of the gateway for that mesh will allow SWIFT Tools to acquire information on all devices in that mesh, including point-to-point signal strength for all links.
- **W-BATCART:** Wireless battery cartridge, 10-pack. For use with wireless pullstations and A/V bases.

Specifications

Maximum Transmit RF Power: 17 dBm

Radio Frequency Range: 902-928 MHz

Temperature Range: 32°F to 120°F (0°C to 49°C)

Humidity: 10% to 93% Non-condensing

Battery Type: 4 Panasonic® CR123A or 4 Duracell® DL123A

Battery Life: 2 year minimum

Battery Replacement: Upon TROUBLE BATTERY LOW display and/or during annual maintenance

Dimensions: 5.6" (142 mm) H x 4.2" (107 mm) W x 2.1" (53 mm) D

Agency Listings and Approvals

The listings and approvals below apply to the W-BG12LX. In some cases, certain modules may not be listed by certain approval agencies or listing may be in process. Consult factory for latest listing status.

UL Listed: S711

CSFM: 7150-0075:0503

FCC ID: AUBWFSPS

NYC Fire Dept: COA #6252, #6253, 6261

FM Approved

Fire-Lite® Alarms, System Sensor®, and SWIFT® are registered trademarks of, and **LiteSpeed™** is a trademark of Honeywell International Inc. Microsoft® and Windows® are registered trademarks of Microsoft Corporation. Duracell® is a registered trademark of Duracell U.S. Operations Inc. Panasonic® is a registered trademark of Panasonic Corporation.

©2018 by Honeywell International Inc. All rights reserved. Unauthorized use of this document is strictly prohibited.



This document is not intended to be used for installation purposes.
We try to keep our product information up-to-date and accurate.
We cannot cover all specific applications or anticipate all requirements.
All specifications are subject to change without notice.

For more information, contact Fire-Lite Alarms. Phone: (800) 627-3473, FAX: (877) 699-4105. Country of Origin: Mexico
www.firelite.com

H365 Series

Addressable Heat Detectors



Addressable Devices

The Fire-Lite® Alarms H365(A), H365R(A), and H365HT(A) addressable plug-in thermal detectors are designed for both performance and aesthetics and are a direct replacement for the H355 Series. A new modern, sleek, contemporary design and advanced thermal technologies make the H365(A) Series ideal for both system operation and building design.

Exclusively for use with Fire-Lite's addressable fire alarm control panels, the H365(A) Series point ID capability allows each detector's address to be set with rotary, decimal address switches, providing exact detector location for emergency personnel to quickly locate a fire during its early stages, potentially saving precious rescue time while also reducing property damage. Two LEDs on each sensor light to provide a local, visible sensor indication.

The H365(A) Series includes fixed temperature, rate-of-rise and high heat fixed temperature detectors that provide effective, intelligent property protection for a variety of applications. Detectors are available for both LiteSpeed™ and CLIP applications as designated.

Features

SLC LOOP:

- Two-wire SLC loop connection
- Unit uses base for wiring

ADDRESSING:

- Addressable by device
- Rotary, decimal addressing
(Refer to the *Fire-Lite panel manuals* for device capacity.)

ARCHITECTURE:

- Designed to meet UL 268 7th Edition
- Sleek, low-profile, stylish design
- State-of-the-art thermistor technology for fast response
- Integral communications and built-in device-type identification
- Built-in tamper resistant feature
- Built-in functional test switch activated by external magnet

OPERATION:

- Fixed temperature model (H365(A)) factory preset to 135°F (57°C)
- Rate-of-rise model (H365R(A)), 15°F (8.3°C) per minute
- High-temperature model (H365HT(A)) factory preset to 190°F (88°C)
- 360°-field viewing angle of the two visual alarm indicators, LEDs blink red in Normal condition and turn on steady red in Alarm
- LEDs blink every time the unit is polled

MECHANICALS:

- Sealed against back pressure
- SEMS screws for wiring of the separate base
- Designed for direct-surface or electrical-box mounting
- Plugs into separate base for ease of installation and maintenance
- Separate base allows interchange of photoelectric, ionization and thermal sensors

OTHER SYSTEM FEATURES:

- Remote test feature from the panel
- Walk test with address display
- Low standby current



OPTIONS:

- Remote LED output connection to optional RA100Z remote LED annunciator

Installation

H365 Series plug-in intelligent thermal detectors use a detachable base to simplify installation, service and maintenance. Installation instructions are shipped with each detector.

Mount detector base (all base types) on an electrical backbox which is at least 1.5" (3.81 cm) deep. For a chart of compatible junction boxes, see *DF-60059*.

NOTE: Because of the inherent supervision provided by the SLC loop, end-of-line resistors are not required. Wiring "T-taps" or branches are permitted for Style 4 (Class "B") wiring only. When using relay or sounder bases, consult the I300(A) installation sheet I56-3626 for device limitations between isolator modules and isolator bases.

Applications

Use thermal detectors for protection of property. For further information, refer to I56-6525, Applications Manual for System Smoke Detectors, which provides detailed information on detector spacing, placement, zoning, wiring, and special applications.

Construction

These detectors are constructed of fire-resistant plastic. The H365 Series plug-in intelligent thermal detectors are designed to commercial standards and offer an attractive appearance.

Operation

Each H365 Series detector uses one of the panel's addresses (total limit is panel dependent) on the Fire-LiteJCI Signaling Line Circuit (SLC). It responds to regular polls from the control panel and reports its type and the status. If it receives a test command from the panel (or a local magnet test), it stimulates its electronics and reports an alarm. It blinks its LEDs when polled and turns the LEDs on when commanded by the panel. The H365 Series offers features and performance that represent the latest in thermal detector technology.

Product Line Information

NOTE: “-IV” suffix indicates CLIP and LiteSpeed device.

NOTE: “A” suffix indicates Canadian version.

H365: White, low-profile intelligent 135°F fixed thermal sensor, LiteSpeed only

H365A: Same as H365 but with ULC listing

H365-IV: Ivory, low-profile intelligent 135°F fixed thermal sensor, LiteSpeed and CLIP

H365A-IV: Same as H365-IV but with ULC listing

H365R: White, low-profile intelligent rate-of-rise thermal sensor, LiteSpeed only

H365RA: Same as H365R but with ULC listing

H365R-IV: Ivory, low-profile intelligent rate-of-rise fixed thermal sensor, LiteSpeed and CLIP

H365RA-IV: Same as H365R-IV but with ULC listing

H365HT: White, low-profile intelligent 190°F fixed thermal sensor, LiteSpeed only

H365HTA: Same as H365H but with ULC listing

H365HT-IV: Ivory, low-profile intelligent 190°F thermal sensor, LiteSpeed and CLIP

H365HTA-IV: Same as H365H-IV but with ULC listing

INTELLIGENT BASES

NOTE: For details on intelligent bases, see DF-60059.

B300-6: White, 6” base, standard flanged low-profile mounting base (CSFM: 7300-1653:0109)

B300-6-IV: Ivory, 6” base, standard flanged low-profile mounting base (CSFM: 7300-1653:0109)

B300A-6: Same as B300-6, ULC listed

B300A-6-IV: Ivory, 6” standard flanged low-profile mounting base, ULC listed

B300-6-BP: Bulk pack of B300-6, package contains 10

B501-WHITE: White, 4” standard European flangeless mounting base. UL/ULC listed (CSFM: 7300-1653:0109)

B501-BL: Black, 4” standard European flangeless mounting base. UL/ULC listed (CSFM: 7300-1653:0109)

B501-IV: Ivory color, 4” standard European flangeless mounting base. UL/ULC listed (CSFM: 7300-1653:0109)

B501-WHITE-BP: Bulk pack of B501-WHITE contains 10

B224RB-WH: White, relay base (CSFM: 7300-1653:0216)

B224RB-IV: Ivory, relay base (CSFM: 7300-1653:0216)

B224RBA-WH: White, relay base, ULC listing

B224RBA-IV: Ivory, relay base, ULC listing

B224BI-WH: White, isolator detector base (CSFM: 7300-1653:0216)

B224BI-IV: Ivory isolator detector base (CSFM: 7300-1653:0216)

B224BIA-WH: White, isolator detector base, ULC listing

B224BIA-IV: Ivory isolator detector base, ULC listing

B200S-WH: White, Intelligent addressable sounder base capable of producing sound output in high or low volume with ANSI Temporal 3, ANSI Temporal 4, continuous tone, marching tone, and custom tone. Uses FlashScan protocol. (CSFM: 7300-1653:0213)

B200S-IV: Ivory, Intelligent addressable sounder base capable of producing sound output in high or low volume with ANSI Temporal 3, ANSI Temporal 4, continuous tone, marching tone, and custom tone. Uses FlashScan protocol. (CSFM: 7300-1653:0213)

B200SA-WH: Same as B200S-WH, ULC listing

B200SA-IV: Same as B200S-IV, ULC listing

B200SCOA-WH: White, Intelligent, programmable sounder base in English/French (required in Canada for ULC applications with CO Series detector applications)

B200SCOA-IV: Ivory Intelligent, programmable sounder base in English/French (required in Canada for ULC applications with CO Series detector applications, ULC listing)

B200S-LF-WH: White, Low Frequency Intelligent, programmable sounder base. Produces a fundamental frequency of 520 Hz +/- 10% with a square wave or its equivalent; designed to meet the NFPA 72 sleeping space requirement. (CSFM: 7300-1653:0238)

B200S-LF-IV: Ivory, Low Frequency Intelligent, programmable sounder base. Produces a fundamental frequency of 520 Hz +/- 10% with a square wave or its equivalent; designed to meet the NFPA 72 sleeping space requirement. (CSFM: 7300-1653:0238)

B200SR-WH: White, Intelligent sounder base capable of producing sound output with ANSI Temporal 3 or continuous tone. Intended for retrofit applications. (CSFM: 7300-1653:0213)

B200SR-IV: Ivory, Intelligent sounder base capable of producing sound output with ANSI Temporal 3 or continuous tone. Intended for retrofit applications. (CSFM: 7300-1653:0213)

B200SRA-WH: Same as B200SR-WH with, ULC listing

B200SRA-IV: Same as B200SR-IV in Ivory color, ULC listing

B200SR-LF-WH: White, Low Frequency Intelligent, programmable sounder base. Produces a fundamental frequency of 520 Hz +/- 10% with a square wave or its equivalent; designed to meet the NFPA 72 sleeping space requirement. Intended for retrofit applications. (CSFM: 7300-1653:0238)

B200SR-LF-IV: Ivory, Low Frequency Intelligent, programmable sounder base. Produces a fundamental frequency of 520 Hz +/- 10% with a square wave or its equivalent; designed to meet the NFPA 72 sleeping space requirement. Intended for retrofit applications. (CSFM: 7300-1653:0238)

MOUNTING KITS AND ACCESSORIES

TR300: White, replacement flange for B210LP(A) base

TR300-IV: Ivory, replacement flange for B210LP(A) base

RA100Z(A): Remote LED annunciator. 3-32 VDC. Mounts to a U.S. single-gang electrical box. For use with B501(A) and B300-6(A).

M02-04-00: Test magnet

M02-09-00: Test magnet with telescoping handle

CK300: Color Kit (includes cover and trim ring), white, 10-pack

CK300-IV: Color Kit (includes cover and trim ring), ivory, 10-pack

CK300-BL: Color Kit (includes cover and trim ring), black, 10-pack

SYSTEM SPECIFICATIONS

Size: 2.0" (5.3 cm) high; base determines diameter

- **B300-6:** 6.1" (15.6 cm) diameter
- **B501:** 4" (10.2 cm) diameter

For a complete list of detector bases see DF-60983

Shipping weight: 3.4 oz. (95 g)

Operating temperature range:

- H365, H365R Series: –4°F to 100°F (–20°C to 38°C)
- H365H Series: –4°F to 150°F (–20°C to 66°C)

Detector spacing: UL approved for 50 ft. (15.24 m) center-to-center, FM approved for 25 x 25 ft. (7.62 x 7.62 m) spacing

Relative humidity: 10% – 93% non-condensing

Thermal ratings: fixed-temperature set point 135°F (57°C), rate-of-rise detection 15°F (8.3°C) per minute, high temperature heat 190°F (88°C)

Mounting: B300-6(A) flanged base, included

See “**Product Line Information: Intelligent Bases,**” if using a different base.

ELECTRICAL SPECIFICATIONS

Voltage range: 15 - 32 volts DC peak

Standby current (max. avg.): 200µA @ 24 VDC (one communication every 5 seconds with LED enabled)

Max current: 4.5 mA @ 24 VDC (“ON”)

Listings and Approvals

Listings and approvals below apply to the H365 Series detectors. In some cases, certain modules may not be listed by certain approval agencies, or listing may be in process. Consult factory for latest listing status.

- UL/ULC Listing: S2517
- FM Approved
- CSFM: 7272-0075:0501

LiteSpeed™ is a trademark and Fire•Lite® Alarms is a registered trademark of Honeywell International Inc.
©2019 by Honeywell International Inc. All rights reserved. Unauthorized use of this document is strictly prohibited.



This document is not intended to be used for installation purposes.
We try to keep our product information up-to-date and accurate.
We cannot cover all specific applications or anticipate all requirements.
All specifications are subject to change without notice.

For more information, contact Fire•Lite Alarms. Phone: (800) 627-3473, FAX:(877) 699-4105.
www.firelite.com

Country of Origin: Mexico



Indoor Selectable-Output Horns, Strobes, and Horn Strobes for Wall Applications

SpectrAlert® Advance audible visible notification products are rich with features guaranteed to cut installation times and maximize profits.



SPECTRAlert
ADVANCE
from System Sensor

Features

- Plug-in design with minimal intrusion into the back box
- Tamper-resistant construction
- Automatic selection of 12- or 24-volt operation at 15 and 15/75 candela
- Field-selectable candela settings on wall units: 15, 15/75, 30, 75, 95, 110, 115, 135, 150, 177, and 185
- Horn rated at 88+ dBA at 16 volts
- Rotary switch for horn tone and three volume selections
- Universal mounting plate for wall units
- Mounting plate shorting spring checks wiring continuity before device installation
- Electrically Compatible with legacy SpectrAlert devices
- Compatible with MDL3 sync module
- Listed for ceiling or wall mounting

The SpectrAlert Advance series offers the most versatile and easy-to-use line of horns, strobes, and horn strobes in the industry. With white and red plastic housings, wall and ceiling mounting options, and plain and FIRE-printed devices, SpectrAlert Advance can meet virtually any application requirement.

Like the entire SpectrAlert Advance product line, wall-mount horns, strobes, and horn strobes include a variety of features that increase their application versatility while simplifying installation. All devices feature plug-in designs with minimal intrusion into the back box, making installations fast and foolproof while virtually eliminating costly and time-consuming ground faults.

To further simplify installation and protect devices from construction damage, SpectrAlert Advance utilizes a universal mounting plate with an onboard shorting spring, so installers can test wiring continuity before the device is installed.

Installers can also easily adapt devices to a suit a wide range of application requirements using field-selectable candela settings, automatic selection of 12- or 24-volt operation, and a rotary switch for horn tones with three volume selections.

Agency Listings



S4011 (chimes, horn strobes, horns)
S5512 (strobes)



3023572



MEA452-05-E



7125-1653:186 (indoor strobes)
7125-1653:188 (horn strobes,
chime strobes)
7135-1653:189 (horns, chimes)

SpectrAlert Advance Specifications

Architect/Engineer Specifications

General

SpectrAlert Advance horns, strobes, and horn strobes shall mount to a standard 4 × 4 × 1½-inch back box, 4-inch octagon back box, or double-gang back box. Two-wire products shall also mount to a single-gang 2 × 4 × 17/8-inch back box. A universal mounting plate shall be used for mounting ceiling and wall products. The notification appliance circuit wiring shall terminate at the universal mounting plate. Also, SpectrAlert Advance products, when used with the Sync•Circuit™ Module accessory, shall be powered from a non-coded notification appliance circuit output and shall operate on a nominal 12 or 24 volts. When used with the Sync•Circuit Module, 12-volt-rated notification appliance circuit outputs shall operate between 8.5 and 17.5 volts; 24-volt-rated notification appliance circuit outputs shall operate between 16.5 and 33 volts. Indoor SpectrAlert Advance products shall operate between 32 and 120 degrees Fahrenheit from a regulated DC or full-wave rectified unfiltered power supply. Strobes and horn strobes shall have field-selectable candela settings including 15, 15/75, 30, 75, 95, 110, 115, 135, 150, 177, and 185.

Strobe

The strobe shall be a System Sensor SpectrAlert Advance Model _____ listed to UL 1971 and shall be approved for fire protective service. The strobe shall be wired as a primary-signaling notification appliance and comply with the Americans with Disabilities Act requirements for visible signaling appliances, flashing at 1 Hz over the strobe's entire operating voltage range. The strobe light shall consist of a xenon flash tube and associated lens/reflector system.

Horn Strobe Combination

The horn strobe shall be a System Sensor SpectrAlert Advance Model _____ listed to UL 1971 and UL 464 and shall be approved for fire protective service. The horn strobe shall be wired as a primary-signaling notification appliance and comply with the Americans with Disabilities Act requirements for visible signaling appliances, flashing at 1 Hz over the strobe's entire operating voltage range. The strobe light shall consist of a xenon flash tube and associated lens/reflector system. The horn shall have three audibility options and an option to switch between a temporal three pattern and a non-temporal (continuous) pattern. These options are set by a multiple position switch. On four-wire products, the strobe shall be powered independently of the sounder. The horn on horn strobe models shall operate on a coded or non-coded power supply.

Synchronization Module

The module shall be a System Sensor Sync•Circuit model MDL3 listed to UL 464 and shall be approved for fire protective service. The module shall synchronize SpectrAlert strobes at 1 Hz and horns at temporal three. Also, while operating the strobes, the module shall silence the horns on horn strobe models over a single pair of wires. The module shall mount to a 411/16 × 411/16 × 21/8-inch back box. The module shall also control two Style Y (class B) circuits or one Style Z (class A) circuit. The module shall synchronize multiple zones. Daisy chaining two or more synchronization modules together will synchronize all the zones they control. The module shall not operate on a coded power supply.

Physical/Electrical Specifications

Standard Operating Temperature	32°F to 120°F (0°C to 49°C)
Humidity Range	10 to 93% non-condensing
Strobe Flash Rate	1 flash per second
Nominal Voltage	Regulated 12 DC/FWR or regulated 24 DC/FWR ¹
Operating Voltage Range²	8 to 17.5 V (12 V nominal) or 16 to 33 V (24 V nominal)
Operating Voltage Range MDL3 Sync Module	8.5 to 17.5 V (12 V nominal) or 16.5 to 33 V (24 V nominal)
Input Terminal Wire Gauge	12 to 18 AWG
Wall-Mount Dimensions (including lens)	5.6" L × 4.7" W × 2.5" D (142 mm L × 119 mm W × 64 mm D)
Horn Dimensions	5.6" L × 4.7" W × 1.3" D (142 mm L × 119 mm W × 33 mm D)
Wall-Mount Trim Ring Dimensions (sold as a 5 pack) (TR-HS)	5.7" L × 4.8" W × 0.35" D (145 mm L × 122 mm W × 9 mm D)

Notes:

1. Full Wave Rectified (FWR) voltage is a non-regulated, time-varying power source that is used on some power supply and panel outputs.
2. P, S, PC, and SC products will operate at 12 V nominal only for 15 and 15/75 cd.

UL Current Draw Data

UL Max. Strobe Current Draw (mA RMS)						UL Max. Horn Current Draw (mA RMS)					
	Candela	8–17.5 Volts		16–33 Volts		Sound Pattern	dB	8–17.5 Volts		16–33 Volts	
		DC	FWR	DC	FWR			DC	FWR	DC	FWR
Standard Candela Range	15	123	128	66	71	Temporal	High	57	55	69	75
	15/75	142	148	77	81	Temporal	Medium	44	49	58	69
	30	NA	NA	94	96	Temporal	Low	38	44	44	48
	75	NA	NA	158	153	Non-temporal	High	57	56	69	75
	95	NA	NA	181	176	Non-temporal	Medium	42	50	60	69
	110	NA	NA	202	195	Non-temporal	Low	41	44	50	50
	115	NA	NA	210	205	Coded	High	57	55	69	75
High Candela Range	135	NA	NA	228	207	Coded	Medium	44	51	56	69
	150	NA	NA	246	220	Coded	Low	40	46	52	50
	177	NA	NA	281	251						
	185	NA	NA	286	258						

UL Max. Current Draw (mA RMS), 2-Wire Horn Strobe, Standard Candela Range (15–115 cd)									
DC Input	8–17.5 Volts		16–33 Volts		30	75	95	110	115
	15	15/75	15	15/75					
Temporal High	137	147	79	90	107	176	194	212	218
Temporal Medium	132	144	69	80	97	157	182	201	210
Temporal Low	132	143	66	77	93	154	179	198	207
Non-Temporal High	141	152	91	100	116	176	201	221	229
Non-Temporal Medium	133	145	75	85	102	163	187	207	216
Non-Temporal Low	131	144	68	79	96	156	182	201	210
FWR Input									
Temporal High	136	155	88	97	112	168	190	210	218
Temporal Medium	129	152	78	88	103	160	184	202	206
Temporal Low	129	151	76	86	101	160	184	194	201
Non-Temporal High	142	161	103	112	126	181	203	221	229
Non-Temporal Medium	134	155	85	95	110	166	189	208	216
Non-Temporal Low	132	154	80	90	105	161	184	202	211

UL Max. Current Draw (mA RMS), 2-Wire Horn Strobe, High Candela Range (135–185 cd)									
DC Input	16–33 Volts				FWR Input	16–33 Volts			
	135	150	177	185		135	150	177	185
Temporal High	245	259	290	297	Temporal High	215	231	258	265
Temporal Medium	235	253	288	297	Temporal Medium	209	224	250	258
Temporal Low	232	251	282	292	Temporal Low	207	221	248	256
Non-Temporal High	255	270	303	309	Non-Temporal High	233	248	275	281
Non-Temporal Medium	242	259	293	299	Non-Temporal Medium	219	232	262	267
Non-Temporal Low	238	254	291	295	Non-Temporal Low	214	229	256	262

Horn Tones and Sound Output Data

Horn and Horn Strobe Output (dBA)										
Switch Position	Sound Pattern	dB	8–17.5 Volts		16–33 Volts		24-Volt Nominal			
			DC	FWR	DC	FWR	Reverberant		Anechoic	
			DC	FWR	DC	FWR	DC	FWR	DC	FWR
1	Temporal	High	78	78	84	84	88	88	99	98
2	Temporal	Medium	75	75	80	80	86	86	96	96
3	Temporal	Low	71	71	76	76	83	80	94	89
4	Non-Temporal	High	82	82	88	88	93	92	100	100
5	Non-Temporal	Medium	78	78	85	85	90	90	98	98
6	Non-Temporal	Low	73	74	81	81	88	84	96	92
7†	Coded	High	82	82	88	88	93	92	101	101
8†	Coded	Medium	78	78	85	85	90	90	97	98
9†	Coded	Low	74	75	81	81	88	85	96	92

†Settings 7, 8, and 9 are not available on 2-wire horn strobes.

SpectrAlert Advance Dimensions

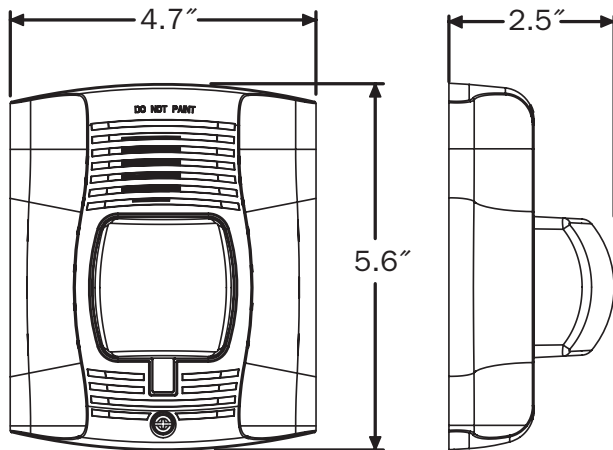

Wall-mount horn strobes

SpectrAlert Advance Ordering Information

Model	Description
Wall Horn Strobes	
P2R	2-Wire Horn Strobe, Standard cd, Red
P2R-P	2-Wire Horn Strobe, Standard cd, Red, Plain
P2R-SP	2-Wire Horn Strobe, Standard cd, Red, "FUEGO"
P2RH	2-Wire Horn Strobe, High cd, Red
P2RH-P	2-Wire Horn Strobe, High cd, Red, Plain
P2W	2-Wire Horn Strobe, Standard cd, White
P2W-P	2-Wire Horn Strobe, Standard cd, White, Plain
P2WH	2-Wire Horn Strobe, High cd, White
P2WH-P	2-Wire Horn Strobe, High cd, White, Plain
P4R	4-Wire Horn Strobe, Standard cd, Red
P4R-P	4-Wire Horn Strobe, Standard cd, Red, Plain
P4RH	4-Wire Horn Strobe, High cd, Red
P4W	4-Wire Horn Strobe, Standard cd, White
Wall Strobes	
SR	Strobe, Standard cd, Red
SR-P	Strobe, Standard cd, Red, Plain
SR-SP	Strobe, Standard cd, Red, "FUEGO"

Model	Description
Wall Strobes (cont.)	
SRH	Strobe, High cd, Red
SRH-P	Strobe, High cd, Red, Plain
SRH-SP	Strobe, High cd, Red, "FUEGO"
SW	Strobe, Standard cd, White
SW-P	Strobe, Standard cd, White, Plain
SWH	Strobe, High cd, White
SWH-P	Strobe, High cd, White, Plain
Horns	
HR	Horn, Red
HW	Horn, White
Accessories	
TR-HS	Trim Ring, Wall, Red
SBBR	Indoor Surface Mount Back Box, Red
SBBW	Indoor Surface Mount Back Box, White

Notes:

All -P models have a plain housing (no "FIRE" marking on cover)

All -SP models have "FUEGO" marking on cover

"Standard cd" refers to strobes that include 15, 15/75, 30, 75, 95, 110, and 115 candela settings.

"High cd" refers to strobes that include 135, 150, 177, and 185 candela settings.



3825 Ohio Avenue • St. Charles, IL 60174
 Phone: 800-SENSOR2 • Fax: 630-377-6495
www.systemsensor.com

©2014 System Sensor.
 Product specifications subject to change without notice. Visit systemsensor.com
 for current product information, including the latest version of this data sheet.
 AVDS10201 • 1/14