



First Security Service, Inc.

Custom Audio Solutions

---

**Fire Alarm Submittals  
For  
Carolina Charter Academy  
8529 Hwy 55  
Angier, NC 27501**

*Prepared By:*

*Joe Dobson*

[joed@firstsecurityserviceinc.com](mailto:joed@firstsecurityserviceinc.com)

*919-730-4327*

4319 Western Park Place • Durham, NC 27705 | PO Box 61779 • Durham, NC 27715  
(919) 383-7610 • 1-800-446-8602 • Fax (919) 383-7362 • [www.firstsecurityserviceinc.com](http://www.firstsecurityserviceinc.com)

---

Security • Structured Cable • Home Theater • Audio/Video • Fire Systems • CCTV • Automated Gates • Access Control

---



## **Carolina Charter Academy Fire Alarm Equipment List**

1	IFP-300	Silent Knight Addressable Fire Alarm Control Panel
2	12V 7Amp	Batteries
1	IPGSM4G	Cellular Fire Alarm Communicator
6	IDP-PULL-DA	Pull Stations-Double Action
6	Stopper II	Pull Station Covers with Horn
18	IDP-Photo	Addressable Photoelectric Smoke Detectors with bases
2	IDP-HEAT-ROR	Addressable Rate of Rise Heat Detectors-135 Degree with bases
29	IDP-FIRE-CO	Addressable Photoelectric CO Detectors with Sounder Base
11	DNRW	Weather Proof Duct Housings w/ Sampling Tubes
11	IDP-PhotoR	Addressable Photoelectric Smoke Detectors
11	RTS151KEY	Remote Test/Reset Stations with Key
25	IDP-Relay	Addressable Relay Modules
6	IDP-Monitor	Addressable Monitor Modules
17	P2WL	Wall Mount Horn/Strobes
31	PC2WL	Ceiling Mount Horn/Strobes
22	SWL	Wall Mount Strobes
2	HWL	Wall Mount Horn
1	EA-200	Temp Alert

## IFP-300 / IFP-300B

### Intelligent Fire Alarm Control Panel

The IFP-300 (red) and IFP-300B (black) are intelligent analog/addressable fire alarm control panels (FACP). The basic IFP-300 panel contains one built in signaling line circuit (SLC), which can support 159 (IDP/SK) System Sensor<sup>®</sup> sensors and 159 IDP/SK modules or 127 (SD) Hochiki<sup>®</sup> devices per loop. Additional SLC loops can be added using the model 6815 SLC expander for SK/IDP devices to increase the overall point capacity to a maximum of 300 points per panel, or model 5815XL for SD devices to increase the overall point capacity to a maximum of 254 points per panel.

IFP-300 has the interconnection capability for up to 32 panels. The system has two modes of operation, multiple panels covering one larger building, or multiple independent buildings. To network panels together use the SK-NIC network interface card. Copper wire or fiber optic cable panel connectivity can be used within the same networked system.

IFP-300 has a built-in dual phone line, digital alarm communicator/transmitter (DACT), IP or optional cellular technologies, Form C trouble relay, and two programmable Form C relays. IFP-300 has powerful features such as detector sensitivity, day/night thresholds, drift compensation, pre-trouble maintenance alert, and calibration trouble alert.

The IFP-300 supports a variety of devices, including RA-2000, RA-1000 or RA-100 remote annunciator, 5824 serial/parallel printer interface module (for printing system reports), RPS-1000 power module, and IDP, SK or SD devices.



**IFP-300B**

## FEATURES & BENEFITS

- Network support for up to 32 Sites
- Built-in support for up to 159 IDP/SK detectors and 159 IDP/SK modules or 127 SD SLC devices
- Four line LCD display with 40 characters per line
- Available in a red or black cabinet
- IFP-300 can be surface or flush mounted
- Built-in USB interface for convenient and quick programming
- Firmware can be upgraded in the field
- Network card allows copper network connection with a multi-mode or single-mode fiber connection option
- Built-in dual phone line, digital alarm communicator/transmitter (DACT), IP or optional cellular technologies
- JumpStart AutoProgramming feature for easy programming
- Supports up to four SWIFT wireless gateways. Each gateway can have up to 49 wireless devices
- Supports Class B (Style 4) and Class A (Style 6 or Style 7 configuration for SLC, and SBUS
- Built in synchronization for appliances from AMSECO, Gentex, System Sensor, and Wheelock

# IFP-300 Technical Specifications

## PHYSICAL:

**Overall Dimensions:** 26.4"H x 16.4"W x 4.11"D

**Weight:** 45 lbs.

**Color:** Red or Black

## ENVIRONMENTAL

**Operating Temperature:** 32°F to 120°F (0°C to 49°C)

**Humidity:** 0 to 93% relative humidity (non-condensing)

## ELECTRICAL:

**IFP-300 Primary AC:** 120VAC @ 60 Hz, 3.3A Total Accessory Load: 6A @ 24VDC power-limited

**Standby Current:** 190mA

**Alarm Current:** 250mA

**Battery Charging Capacity:** 17 to 55AH

**Battery Size:** 18AH max, allowed in control panel cabinet. Larger capacity batteries can be housed in RBB accessory cabinet.

## AGENCY LISTINGS AND APPROVALS

**NFPA 13, NFPA 15, NFPA 16, NFPA 70, & NFPA 72:** Central Station; Remote Signalling; Local Protective Signalling Systems; Auxiliary Protected Premises Unit; & Water Deluge Releasing Service

**UL Listed**

**CSFM:** 7165-0559:0504

**FDNY:** COA#6245

**Seismic (CA)** (pending)

**FM approved**

## APPROVED RELEASING SOLENOIDS

Asco T8210A107 24 VDC 3 A max 0 Hz

Asco 8210G207 24 VDC 3 A max 0 Hz

## COMPATIBLE DEVICES

See the data sheets listed below for a complete listing of the IDP, SK, SWIFT or SD devices.

**350361:** IDP Device Protocol data sheet

**53623:** SK Device Protocol data sheet

**350360:** SD Device Protocol data sheet

**350615 & 350617:** SWIFT devices data sheet

## ORDERING INFORMATION

**IFP-300:** Intelligent Fire Alarm Control Panel, Red Cabinet.

**IFP-300B:** Intelligent Fire Alarm Control Panel Black Cabinet.

## SBUS ACCESSORIES

**RA-2000, RA-1000, RA-1000R, RA-100, RA-2000GRAY:** Remote annunciators

**6815:** Signal Line Circuit (SLC) Expander for IDP or SK devices

**5815XL:** Signal Line Circuit (SLC) Expander for SD devices

**RPS-1000:** Power Supply

**5496:** NAC Expander

**5824:** Serial/Parallel Module

**5880:** LED I/O Module

**5865-3 or 5865-4:** LED Annunciator

**5883:** Relay Interface

## MISCELLANEOUS ACCESSORIES

**HFSS:** Software Suite. Provides programming, upload/download and event reporting

**RBB:** Remote Battery Box Cabinet. Use for backup batteries up to 35 AH. Dimensions: 16" W x 10" H x 6" D

**SK-SCK:** Seismic Compliance Kit

**SK-NIC:** Network Interface Card

**SK-NIC-KIT:** Installation Accessory Kit

**SK-FML:** Fiber-Optic Multi Mode, transmitter and receiver

**SK-FSL:** Fiber-Optic Single Mode

**CELL-MOD:** Cellular Communicator in Plastic Enclosure

**CELL-CAB-SK:** Cellular Communicator in Metal Enclosure with lock and key

For a complete listing of all compliance approvals and certifications, please visit [www.farenhyt.com](http://www.farenhyt.com).

Microsoft, Windows, and the Windows Logo are registered trademarks or trademarks of Microsoft Corporation

SWIFT<sup>®</sup> and Honeywell<sup>®</sup> are registered trademarks of and Farenhyt<sup>™</sup> is a trademark of Honeywell International, Inc.

This document is not intended to be used for installation purposes. We try to keep our product information up-to-date and accurate. We cannot cover all specific applications or anticipate all requirements. All specifications are subject to change without notice.

For Technical Support, Please call 800-446-6444.

## For more information

Learn more about Honeywell's Farenhyt Series and other products available by visiting [www.farenhyt.com](http://www.farenhyt.com)

## Honeywell Farenhyt

12 Clintonville Road  
Northford, CT 06472  
800-328-0103

351603 | A | 11/17  
© 2017 Honeywell International Inc.

**Honeywell**



# 5495

## Distributed Power Module

The 5495 Distributed Power Module is the most powerful and cost-effective power supply available today. It delivers 6 amps of notification appliance circuit power and built-in synchronization for appliances from System Sensor®, Gentex®, AMSECO®, and Wheelock. The 5495's switch mode power supply design is up to 50% more efficient than competitive linear mode power supplies. Also, ADA retrofits are easier and less expensive with the 5495 because it integrates into current systems without the costly investment in new components.

The 5495 is a 6 amp notification power expander that provides its own AC power connection, battery charging circuit, and backup battery. The 5495 is the cost-effective solution for powering notification appliances required by the Americans with Disabilities Act (ADA). The 5495 has built-in ANSI cadence pattern, which can upgrade older control panels that lack cadence capability.

### CONNECTION TO LOCAL FIRE CONTROL

The 5495 may be connected to a local fire control which utilizes Class A or Class B type notification circuits operating between 9 and 32 VDC. The control panel's notification circuit is connected to one of the inputs on the 5495. The control panel's notification circuit end-of-line resistor is also connected across two terminals on the 5495, which provides supervision between the 5495 and the fire control panel. Polarized audible and/or visual notification devices are then connected to the 5495 signal circuits using the 4.7kΩ end-of-line resistors provided. Since the 5495 draws very little power from the control, it is possible to connect one 5495 to each notification circuit on the control panel and still provide full supervision of the notification circuits all the way back to the control panel.



5495

## FEATURES & BENEFITS

- UL Listed for 6 amps of notification power
- Power supply's advanced switch mode design reduces damaging heat and manages power up to 50% more efficiently than other systems
- Dip switches allow for easy reconfiguration
- 24 VDC filtered output voltage
- Four power-limited notification outputs; 2 Class A or 4 Class B, or 1 Class A and 2 Class B
- Additional continuous auxiliary output
- 3 amps per output circuit
- 2 inputs; 2 Class B or 2 Class A
- Ground fault detector/indicator
- Independent trouble relay
- AC loss delay option shuts off power to non-essential high-current accessories like magnetic door holders
- Built-in synchronization for appliances from System Sensor, Gentex, AMSECO, and Wheelock
- Stand alone operation
- Lightweight design adds to ease of installation and reduces shipping costs
- Operates with most polarized, UL Listed notification devices
- ANSI Cadence pattern output capability built-in

# 5495 Technical Specifications

## Model 5495 Block Diagram

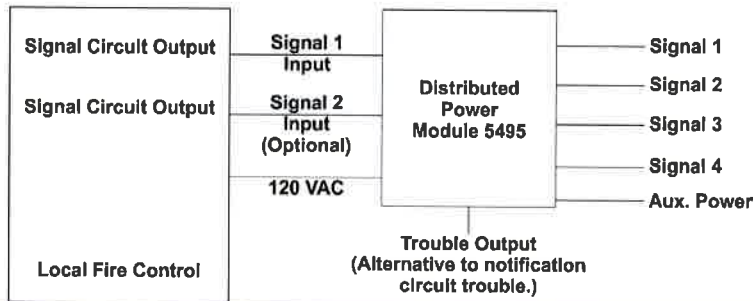

### SUPERVISION

The 5495 supervises a variety of functions including:

- Low AC power
- Low battery condition
- Earth ground fault
- Auxiliary output power limit condition
- EOL supervision trouble or power limited condition at an output

When a trouble condition occurs, the 5495 creates a trouble condition on the host control signal circuits to which it is connected, the 5495 still maintains the ability to be activated by the host control. In addition, the 5495 provides a Form C trouble relay output as an alternative to using the notification circuit trouble.

### PHYSICAL

**Dimensions:** 12.25"W x 16"H x 3"D (30.88 cm W x 40.64 cm H x 7.62 cm D)

### ENVIRONMENTAL

**Operating Temperature:** 32°F to 120°F (0°C to 49°C)

**Humidity:** 10% - 93% non-condensing)

### ELECTRICAL

**AC input:** 120 VAC at 2A

**Output:** 24 VDC at 6A

**Current:** Standby 75mA; Alarm 205mA

**Auxiliary power circuit:** 1

**Notification circuits:** 4

**Output configuration:** 2 Class A (Style Z); 4 Class B (Style Y) (1 Class A & 2 Class B)

**Amps per output circuit:** 3.0 (6.0 amps total)

**Notification circuit output:** Alarm Current (for typical voltages) drawn from main panel's notification appliance circuits.

**12 VDC 6.5 mA**

**24 VDC One input circuit:** 15 mA; Both input circuits: 0 mA

**No. of inputs:** 2

**Input configuration:** 2 Class B or 2 Class A

**Input voltage range:** 9 - 32VDC

**Battery charging capacity:** 35.0AH

### INDICATOR LIGHTS

**AC power on :** Green

**Battery trouble:** Yellow

**Ground fault:** Yellow

**Aux trouble:** Yellow

**Output troubles (1-4):** Yellow

### ORDERING INFORMATION

**5495:** Distributed Power Module

### ACCESSORIES

**SK-SCK:** Seismic Compliance Kit

### AGENCY LISTINGS

- UL listed
- CSFM 7300-0559:123
- Meets NFPA 72 requirements
- MEA 429-92-E Vol XII
- OSHPD (CA) OSP-0065-10

For a complete listing of all compliance approvals and certifications, please visit [www.silentknight.com](http://www.silentknight.com).

Microsoft, Windows, and the Windows Logo are registered trademarks or trademarks of Microsoft Corporation.

System Sensor<sup>®</sup> and Honeywell<sup>®</sup> are registered trademarks of Honeywell International, Inc

This document is not intended to be used for installation purposes. We try to keep our product information up-to-date and accurate. We cannot cover all specific applications or anticipate all requirements. All specifications are subject to change without notice.

For Technical Support, call 800-446-6444.

### For more information

Learn more about Honeywell Silent Knight and other products by visiting [www.silentknight.com](http://www.silentknight.com)

### Honeywell Silent Knight

12 Clintonville Road  
Northford, CT 06472  
800-328-0103

Doc 350395| Rev H1 11/17  
© 2017 Honeywell International Inc.

**Honeywell**  
**SILENT KNIGHT**

## IPGSM-4G

### Single or Dual Path Commercial Fire Communicator

#### General

The IPGSM-4G is a commercial fire alarm communicator that offers contact ID reporting with any Fire Alarm Control Panel (FACP) that has a built-in dialer. This *single or dual path* communicator connects directly to the primary and secondary communication ports of a fire panel's Digital Alarm Communicator Transmitter (DACT). It offers three selectable reporting paths which include: Cellular only, IP only, or IP primary/cellular backup. All signals from the IPGSM-4G are delivered to Honeywell's AlarmNet® Network Control Center, which routes highly encrypted Ethernet data packets via a customer provided internet connection or cellular network to the appropriate central station. The state of the art AlarmNet network control center is fully redundant and monitored 24/7. AlarmNet has the ability to route messages using AlarmNet-I and 800 PLUS services, providing true redundancy and multi-path message delivery.

Alternative communication methods are critical in the marketplace due to VoIP (Voice over IP), migration from POTS (Plain Old Telephone Service) and growth of digital radio networks. The IPGSM-4G's single path communications solution allows one technology to be used (either IP or cellular) to provide the appropriate connectivity to a central station. For added reliability, our exclusive dual path solution allows both technologies (IP and cellular) to be used together for maximum survivability or for local jurisdiction requirements that specify a dual technology system.



## FEATURES & BENEFITS

- Saves the cost of two dedicated phone lines.
- Single or dual path communications- (can communicate to central station using cellular technology, internet, or both.
- Requires no change to the existing Fire Alarm Control Panel configuration. (Connects directly to the primary and secondary telephone ports of a DACT.)
- Operates over the following communication protocols: HSPA+ (4G) HSPA (HSDPA & HSUPA) (3G), EDGE (2G GPRS) (2G).
- Selectable reporting paths and supervision intervals to meet NFPA 72, chapter 26 requirements. (Compliant with NFPA 72 2010 and 2013 supervision requirements.)
- Works over any type of customer provided Ethernet 10/100 based network connection (LAN or WAN), DSL modem or cable modem.
- Data transmits over standard contact-ID protocol but is secured with the industry's advanced encryption standard (AES 256 bit).
- Supports both dynamic (DHCP) or Public and Private Static IP addressing.
- Built-In Power Supply module: On board charging circuit design accommodates back-up battery. Includes primary power and battery supervision.
- Diagnostic LEDs: Signal strength and status indicators.
- Reliable connection: IP and GSM connection tested every day.
- QOS: Quality of Service diagnostics via AlarmNet conveys vital communicator information including when message was received, signal strength, and message path used.
- 7720P Hand-held programmer for easy setup.

The IPGSM-4G is designed to operate over the most common cellular networks, including 3G and HSPA+. Its multi-GSM platform technology automatically chooses the best available cellular signal in the area based on signal strength and seamlessly self-adjusts to maintain critical life safety communication. In addition, it connects to any type of customer provided Ethernet 10/100 base network connection (LAN or WAN), DSL model or cable modem. Our selectable reporting path feature allows the radio to be configured for a single or dual path solution as well as the appropriate supervision intervals based on NFPA 72 requirements. (See diagram below for selectable paths and supervision timing intervals.)

Selectable Path	Description	Supervision Times
2010 GSM	Single Path (cellular only)	5 minutes
2010 IP	Single Path (IP only)	5 minutes
2010 IP & GSM	Dual Path (IP and cellular)	24 hours
2013 GSM	Single Path (cellular only)	1 hour
2013 IP	Single Path (IP only)	1 hour
2013 IP & GSM	Dual Path (IP and cellular)	6 hours

## Operation

When an event occurs, the Fire Alarm Control Panel goes off hook to dial the central station. The IPGSM-4G Dialer Capture Module detects the off-hook condition and provides the fire panel with a dial tone. When the fire panel detects the dial tone, it begins dialing the central station. After the dialing is completed, the Dialer Capture Module returns a handshake to the fire panel. The fire panel then sends the contact ID reports to the Dialer Capture Module, which in turn sends a kiss-off after the report is successfully received from the fire panel. The Dialer Capture Module sends the contact ID reports to the IPGSM communications module. When all the reports are sent, the fire panel goes on-hook. The IPGSM communications module then transmits the messages to the central station either over the GSM network or the Internet (dependent on configuration).

## Easy to Program

The IPGSM-4G communicator can be pre-programmed using the 7720P programmer to enter all central-station information. This is saved to the IPGSM-4G communicator panel memory. When the IPGSM-4G communicator is installed at the site and connected to the Internet/Intranet, it registers itself with the AlarmNet receiver.

For most installations, the only required parameters are:

- Primary City ID (two digits) obtained from your monitoring station.
- Primary Central Station ID (two digits) obtained from your monitoring station.
- Primary Subscriber ID (four digits) obtained from your monitoring station.
- Communication Module's MAC ID, and MAC CRC number located on outside of box, and inside of the module.

All of these parameters are assigned by the monitoring station.

**Note:** Some assembly is required. See Installation and Setup Guide #800-12454 for full details.

## Fire Communicator Capability

The IPGSM-4G is compatible with fire panels that use the Contact ID communications format as described in the SIA DC-05 standard.

## AlarmNet

Honeywell's AlarmNet has been the nationwide leader in alarm communications technology since 1986. A reliable alternative for the transmission of alarm signals, our radio network provides extensive coverage in the United States and Canada. AlarmNet Network Control center processes signals from powerful servers in multiple locations equipped with 24/7 infrastructure support. The AlarmNet network consist of redundant hardware servers, hot back-up databases and generators with battery back-up at all locations to ensure continuity of service. Signals from Alarm-Net are transmitted to the central station's receivers using multiple communications paths consisting of the Internet, radio network or toll-free POTS service.

## Installation Requirements

### UL COMPLIANCE

To meet UL864/NFPA, ensure the following:

- IPGSM-4G must be installed in accordance with NFPA (National Fire Protection Association) standards 70 and 72.
- IPGSM-4G must be mounted in the same room and within 20 feet of the fire panel.
- IPGSM-4G, and all equipment used for the IP connection (such as the router, hub, modem, etc.) shall be listed, must be powered from an un-switched branch circuit, and be provided with appropriate standby power.
- IPGSM-4G must use the 7AH battery (not supplied) to provide 24-hour backup capability.



# IPGSM-4G Technical Specifications

## ELECTRICAL

### Transformer:

**Primary:** 120VAC, 60Hz, 0.5A

**Secondary:** 18VDC, 50VA

### Battery:

**One 12 V 7.0 AH lead-acid battery:** (not supplied)

**Battery charging current:** 1 Amp maximum

**Battery discharge current:** Standby 230mA, Active 950mA

## CABINET SPECIFICATIONS

**Dimensions:** 14.875" H x 12.75" W x 3.0" D (37.8 cm H x 32.4 cm W x 7.6 cm D)

**Color:** Red

## SHIPPING SPECIFICATIONS

**Weight:** 5.3 lbs. (6.94 kg)

**Dimensions:** 15.625" H x 13.79" W x 9.25" D (39.7 cm H x 34.9 cm W x 23.9 cm D)

## TEMPERATURE AND HUMIDITY RANGES

This system meets NFPA requirements for operation at 0 - 49°C/32 - 120°F and at a relative humidity 93% ± 2% RH (non condensing at 32°C ± 2°C (90°F ± 3°F)). However, the useful life of the system's standby batteries and the electronic components may be adversely affected by extreme temperature ranges and humidity. Therefore, it is recommended that this system and its peripherals be installed in an environment with a normal room temperature of 15 - 27°C/60 - 80°F.

## PRODUCT LINE INFORMATION

**IPGSM-4G:** Internet and Digital Cellular Fire Alarm Communicator Panel. Includes red cabinet with Ademco® key and lock, wall outlet box, Dialer Capture Module, IGSM Communications Module, antenna & mounting adapter, PowerBoost1 power supply, LED display board, transformer, manual, & required screws, cables, etc.

### Antenna External Hardware

**GSM-ANT3DB:** 3db gain external/remote antenna

**WA7626-CA:** SNA to N Adapter

**7626-50HC:** 50 ft. antenna cable, low loss

**7626-25HC:** 25 ft. antenna cable, low loss

**Note:** The GSM-ANT3DB and the WA7626-CA are both required for installing an external antenna along with the necessary cable needed (7626-50HC: 50 ft. or 7626-25HC: 25 ft.)

### Other Accessories

**7720P:** IPGSM-4G hand held programmer.

**HPTCOVER:** Plug-in transformer box for IPGSM communicator.

**BAT-1270:** Battery 12 Volts, 7 AH, sealed.

## AGENCY LISTINGS AND APPROVALS

The listings and approvals below apply to the basic IPGSM-4G communicator panel. In some cases, certain modules may not be listed by certain approval agencies, or listing may be in process.

*Consult factory for latest listing status.*

**UL Listed:** S789

**CSFM:** 7300-1645:0199

**FDNY:** COA #6219

Ademco® and AlarmNet® are registered trademarks of Honeywell International Inc.

This document is not intended to be used for installation purposes. We try to keep our product information up-to-date and accurate. We cannot cover all specific applications or anticipate all requirements. All specifications are subject to change without notice.

## For more information

Learn more about Honeywell's IPGSM-4G and other products available by visiting [www.honeywellpower.com](http://www.honeywellpower.com).

## Honeywell Power Products

12 Clintonville Road  
Northford, CT 06472-1610  
877.HPP.POWER  
[www.honeywell.com](http://www.honeywell.com)

DH-60769 | F | 06/17  
©2017 Honeywell International Inc.

**Honeywell**  
THE POWER OF CONNECTED

# Farenhyt



## Addressable Single Action and Dual Action Pull Stations

### IDP-Pull-SA & IDP-Pull-DA

The IDP-Pull-SA is a single action pull station requiring only one motion to activate the station. The IDP-Pull-DA is a dual action pull station requiring two motions to activate the station. Both pull stations are designed to work with Silent Knight IFP-series fire alarm control panels (FACPs).

### Features

- Installer can open station without causing an alarm condition
- Dual-color LED is visible through handle of station blinks green to indicate normal operation and remains steady red in an alarm condition
- Key operated test and reset lock using lock plate actuator
- Key matches compatible FACP locks
- Meets the Americans with Disabilities Act Accessibility Guidelines (ADAAG) controls and operating mechanisms guidelines (Section 4.1.3[13])
- Meets ADA requirement for 5 lbs maximum pull force to active
- Shell, door, and handle molded from durable LEXAN®
- Reliable analog communications for trouble-free operation
- Braille text on station handle
- Handle latches in down position and the word *Activated* appears, clearly indicating the station has been pulled
- Rotary address switches for fast installation
- UL Listed, including UL 38, Standard of Manually Actuated Signaling System

### Installation

The IDP-Pull-SA and IDP-Pull-DA can be surface mounted to an SB-I/O surface back box or semi-flush mounted on a standard single-gang with a minimum depth of 2.13" (5.40 cm) or double-gang or 4" (10.61 cm) square electrical box. You can also use the optional (System Sensor® PN BG-TR) trim ring if the station is being semi-flush mounted.

### Compatibility

The IDP-Pull-SA and IDP-Pull-DA are compatible with the following FACPs:

- IFP-2000 / RPS-2000 Intelligent Fire Panel
- IFP-2000ECS Emergency Communication System with Fire Panel
- IFP-1000 / ECS Intelligent Fire Panel

## Agency Listings



**MEA**  
67-02-E Vol. IX  
For IDP-Pull-DA



IDP-Pull-SA



IDP-Pull-DA

- IFP-100 / ECS Intelligent Fire Panel
- IFP-50 Intelligent Fire Panel

P/N 350286 Rev G

© 2015 Honeywell International Inc

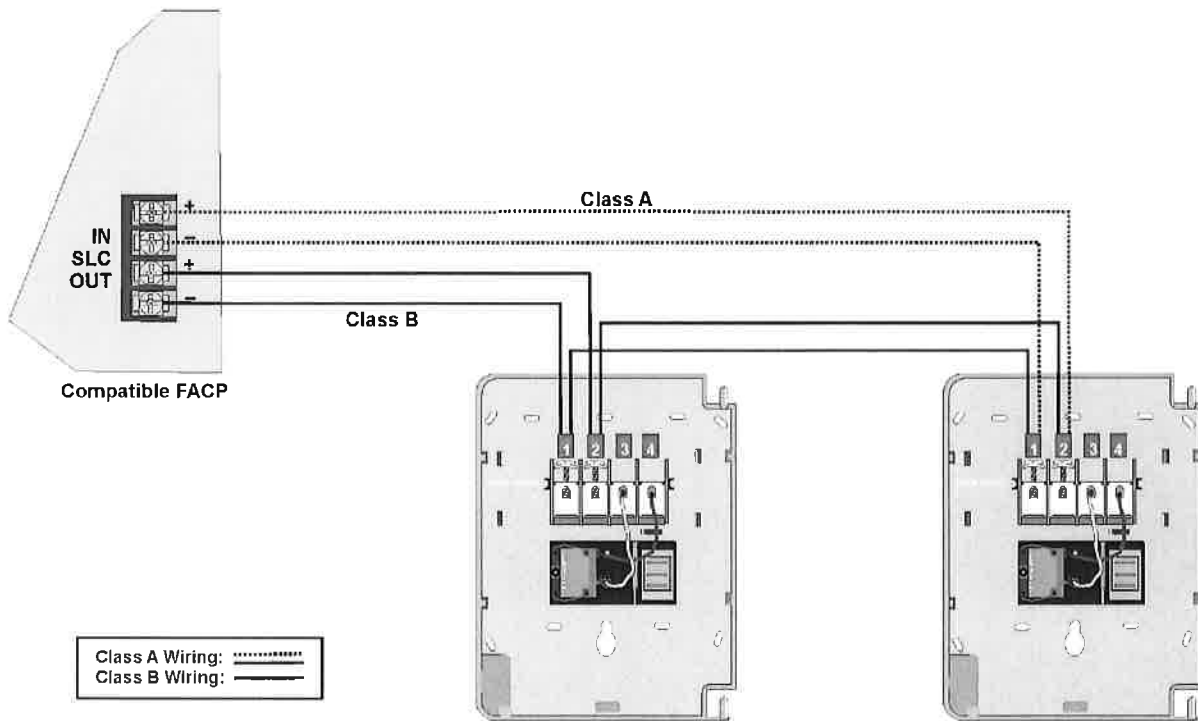

Wiring IDP-Pull-SA & IDP-Pull-DA Pull Stations

## Specifications\*

### Physical

Height: 5.5" (14 cm)

Width: 4" (10.2 cm)

Depth: 5.4 oz. (3.7 cm)

Housing Material: LEXAN polycarbonate resin

Bi-Colored LED:

Blinking Green: Normal

Steady Red: Alarm

Switch: Single pole, single throw (SPST) normally open (N/O) switch which closes upon activation of the pull station

### Electrical

Operating Voltage: 15–32 VDC

SLC Standby and Alarm Current: 350  $\mu$ A

Wire Gauge: Up to 12 AWG (3.1 mm<sup>2</sup>)

### Environmental

Operating Temperature 32° – 120°F (0°C – 49°C)

Humidity: 10% – 93% non-condensing

## Ordering Information

IDP-Pull-SA	Single Action Pull Station
IDP-Pull-DA	Dual Action Pull Station

## Accessories

BG-TR	Optional trim ring.
SB-I/O	Surface backbox, indoor/outdoor.

\* Unless otherwise noted, specifications apply to IDP-Pull-SA and IDP-Pull-DA.



**SILENT  
KNIGHT**

by Honeywell

This document is not intended to be used for installation purposes. We try to keep our product information up-to-date and accurate. We cannot cover all specific applications or anticipate all requirements. All specifications are subject to change without notice. For more information, contact Silent Knight 12 Clintonville Road, Northford, CT 06472-1610 Phone: (800) 328-0103, Fax: (203) 484-7118. For Technical Support, Please call 800-446-6444. [www.farenhyt.com](http://www.farenhyt.com)

# STI STOPPER II®



STI-1100

## PRODUCT OVERVIEW

This protective cover has been helping to stop false fire alarms around the world for more than 30 years, without restricting legitimate alarms. All models offer excellent protection against physical damage (both accidental and intentional) and several against severe environments both inside and out. It is ideal for schools, colleges, hospitals, nursing homes, stores, hotels and public buildings of almost every kind where there is a threat of false alarms.

## HOW IT WORKS

Stopper II consists of a clear, tamperproof, tough polycarbonate shield and frame, but the line includes models with the option of a piezo horn, spacer, Form "C" dry relay contact and gaskets. The cover accommodates most manual pull stations. When the Stopper II with horn is lifted to gain access to the protected alarm, a piercing self-contained 95 or 105 dB warning horn (at one foot) sounds. Immediate attention is drawn to the area and a prankster will either run or be caught. The cover is connected to the frame by a cable. When the cover is lifted, it drops off of the frame and a horn will sound (models with horn) until the cover is snapped back onto the frame or for the life of the battery.

## KEY FEATURES

### General Information

- Proven effective for more than 30 years in helping stop false fire alarms without restricting legitimate alarms.
- Can be used as a guard against physical damage to a manual pull station, with or without the optional warning horn.
- Protect devices such as EPOs, call boxes, telephones and emergency shutdowns by changing the color and messaging.
- Three year guarantee against breakage of polycarbonate in normal use (one year on electro mechanical and electronic components).

### Design

- Larger sizes and surface mounted pull stations accommodated with STI-3100 conduit spacer.
- Weather models have closed cell gaskets.
- The Stopper II design is a registered trademark of Safety Technology International, Inc.

### Construction

- UL Listed to U.S. and Canadian safety standards (also for custom labeling).

### Installation

- When covering a pull station outside, UL requires stations to be listed for outdoor use.
- Typical working properties of polycarbonate are -40° to 250°F (-40° to 121°C).

### Electronics

- Power source is a 9V DC alkaline battery included on standard Stopper II (remote powered unit available).
- "RC" models include one Form "C" dry relay contact and are capable of operating from 9-24V DC remote power or 9V DC battery power.

### Options

- Optional horn has a choice of 95 or 105 dB at one foot.
- Standard red units have "In Case of Fire..." label unless specified with "no label" or "custom label" (extra charge for custom label).
- Horn housing is available in red, blue, green or yellow with optional custom labeling.

# STI Stopper II®

## Dimensions and Technical Information

### MODELS AVAILABLE

#### Stopper II® Models Indoor Use

- STI-1100\* With horn for flush mount
- STI-1130\* With horn and spacer
- STI-1200\* Without horn flush mount
- STI-1230\* Without horn with spacer

#### Weather Stopper® with gaskets (Indoor/Outdoor rated)

- STI-1150\* Stopper II with horn flush mount
- STI-1155\* Stopper II with horn and spacer
- STI-1250\* STI-1200 flush mount and gasket
- STI-3150\* STI-1200 with spacer and gaskets

#### Accessories

- STI-3100 2" conduit spacer with 1/2" conduit entry (no gaskets included)
- STI-3104 2" conduit spacer with 3/4" conduit entry (includes one 3/4" conduit entry gasket)
- STI-1102 Replacement horn for cover with alarm
- STI-1280 Backplate for Stopper II and Weather Stopper series

- \* Add NR for no label on horn housing
- Add CR for custom label on horn housing

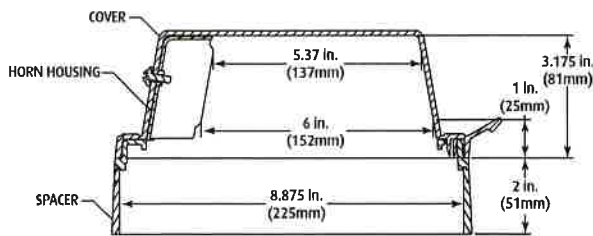

SIDE VIEW  
MODELS WITH HORN (STI-1100 Series)

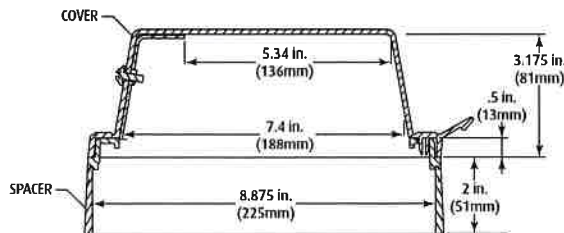

SIDE VIEW  
MODELS WITHOUT HORN (STI-3150 Series)

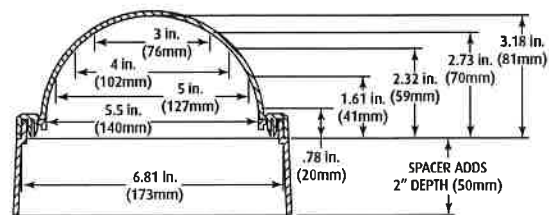

ALL MODELS END VIEW

### APPROVALS & WARRANTY

#### TESTING

It has been tested and approved or listed by:

- UL/cUL Listed No. S2466
- For fire alarm applications, UL38 requires outdoor listed stations for outdoor use
- Factory Mutual No. OG6A2.AY (STI-1100 and STI-1130 only)
- State of California (obtain local fire marshal approval)
- MEA 49-00-E (STI-1200)
- Flush models ADA Compliant. Surface models ADA Compliant for operation (UL Certified No. S2466)
- Weather Stopper® versions designed to meet the requirements of IP54.
- The indoor/outdoor rated station covers, when mounted on a smooth surface, provide a rain tight seal similar to a 3R enclosure rating.

#### WARRANTY

Three year guarantee against breakage of polycarbonate in normal use (one year on electro mechanical and electronic components).

### IMPORTANT NOTICE

Stopper II "FIRE" models are intended to be used in areas where the incidence of false fire alarms from manual pull stations is high or has proven to be a serious problem. Any disadvantage of this device is more than balanced when one considers the consequences of false fire alarms, especially if fire service personnel and equipment are responding to a false fire alarm when they are needed for a real fire somewhere else. Add to this the disruption to the facility when false alarms occur. If you have, or may have, a problem with false fire alarms or physical/weather damage to your fire alarm activation devices, the Stopper II could prove invaluable.

\*WARNING: ⚠ For RC models: UL Listing does not permit relay contacts to connect to the fire alarm or a life safety function. The power supply for horns, according to UL Listing, cannot be connected to a UL Listed fire alarm system. For electrical specifications see install book. RC models contain one set of Form "C" dry contacts. Contacts rated 30 VAC/VDC 1 amp.

- EXTERNAL DIMENSIONS:
- Flush 7.2 W x 10.2 H x 3.3 D in. (183x259x84mm)
  - Surface 7.2 W x 10.2 H x 5.5 D in. (183x259x140mm)



**Safety Technology  
International**

2306 Airport Road  
Waterford, Michigan  
48327, USA

Tel: 248-673-9898  
Fax: 248-673-1246  
Toll-free: 800-888-4784  
info@sti-usa.com  
www.sti-usa.com

Taylor House  
34 Sherwood Road  
Bromsgrove, Worcestershire  
B60 3DR, England

Tel: +44 (0)1527 520 999  
Fax: +44 (0)1527 501 999  
info@sti-emea.com  
www.sti-emea.com

# Farenhyt



**SILENT  
KNIGHT**

by Honeywell  
Intelligent Devices

## Intelligent Photoelectric Smoke Detector & Photoelectric Smoke with Thermal

### IDP-Photo, IDP-Photo-T and IDP-PhotoR

The IDP-Photo is a photoelectric smoke detector and the IDP-Photo-T is a photoelectric smoke detector with thermal. These plug in smoke detectors, with integral communication, provide features that surpass conventional detectors and are for use with Silent Knight IFP-series fire alarm control panels (FACPs).

Detector sensitivity can be programmed from the FACP software. Sensitivity is continuously monitored and reported to the FACP. Point ID capability allows each detector's address to be set with rotary address switches, providing exact detector locations for selective maintenance when chamber contamination reaches unacceptable levels.

IDP-Photo and IDP-Photo-T have a unique optical sensing chamber that is engineered to sense smoke produced by a wide range of combustion sources. In the IDP-Photo-T, dual electronic thermistors add 135°F (57°C) thermal technology to maximize detection.

The IDP-PhotoR is a remote test capable detector for use with the DNR (W) duct smoke detectors. It is UL 268A listed when used with the DNR (W) duct smoke detector.

### Features

- Sleek, low-profile design
- Reliable analog communications for trouble-free operation
- Age resistant polymer housing
- Dual electronic thermistor design on the IDP-Photo-T
- Superior EMI resistance for reliability
- Simple field cleaning for code compliance
- Variety of mounting options to meet any application
- Dual LED indicators for 360° visibility
- Detector transmits signal to indicate maintenance is required
- Optional remote LED annunciator (System Sensor® PN RA100Z)
- Plug-in mounting provides ease of installation
- Tamper-proof feature available on mounting bases
- Listed for use in duct applications
- Rotary address switches for fast installation
- UL Listed



**MEA**  
225-02-E Vol. V



IDP-Photo (Base not Included)

### Installation

The IDP-Photo and IDP-Photo-T plug into a compatible IDP-series detector base. The IDP-PhotoR is a remote test capable detector for use with the DNR (W) duct smoke detector.

### Compatibility

The IDP-Photo, IDP-Photo-T and IDP-PhotoR are compatible with the following IDP-series detector bases:

- B210LP 6" Mounting Base
- B501 4" Mounting Base
- B224BI 6" Isolator Base
- B224RB 6" Relay Base
- B200SR 6" Sounder Base

The IDP-Photo, IDP-Photo-T and IDP-PhotoR are compatible with the following FACPs:

- IFP-2000 / RPS-2000 Intelligent Fire Panel
- IFP-2000ECS Emergency Communication System with Fire Panel
- IFP-1000 / ECS Intelligent Fire Panel
- IFP-100 / ECS Intelligent Fire Panel
- IFP-50 Intelligent Fire Panel
- IFP-25 Intelligent Fire Panel

P/N 350280 Rev H

Copyright © 2017 Honeywell International Inc.

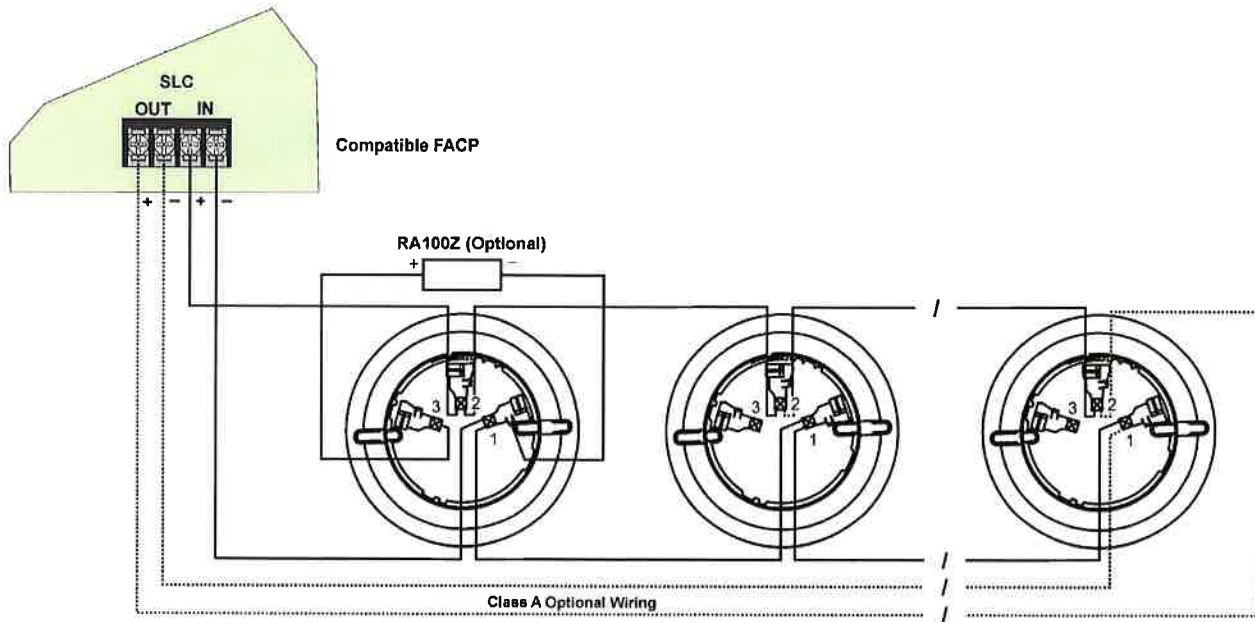

Wiring IDP-Series Detector Mounting Bases

## Wiring IDP-Series Detector Mounting Bases

### Specifications\*

#### Physical

Height: 2.0" (5.0 cm)

Diameter: 4.1" (10.4 cm) installed in B501 base

#### Electrical

Operating Voltage: 15–32 VDC

SLC Standby and Alarm Current: 300  $\mu$ A

#### Environmental

Operating Temperature

IDP-Photo: 32° – 120°F (0°C – 49°C)

IDP-Photo-T: 32° – 100°F (0°C – 38°C)

Humidity: 10% – 93% non-condensing

#### Other Ratings

IDP-Photo-T Thermal: Fixed temperature setpoint 135°F (57°C)

Velocity: 0 – 4000 fpm (0 – 20 m/sec) (suitable for installation in ducts)

IDP-Photo Insect Screen Hole Size: 0.016" (0.41 mm) nominal

### Ordering Information

IDP-Photo	Photoelectric Smoke Detector
IDP-Photo-T	Photoelectric Smoke Detector with Thermal (135°F)
IDP-PhotoR	Photoelectric smoke detector, remote test capable, for use with DNR (W) duct smoke detector

### Accessories

RA100Z	Remote LED Annunciator.
XR2B	Detector Removal Tool. A removal and replacement tool for IDP plug-in detectors. Includes the T55-127-000.
M02-04-01	Detector Test Magnet.
M02-09-00	Test Magnet with Telescoping Handle.
XP-4	Extension Pole for XR2B. Extends from 5 – 15 ft.
T55-127-000	Detector Removal Head.
BCK-200B	Black Detector Kit. For IDP-series detectors.

\* Unless otherwise noted, specifications apply to IDP-Photo and IDP-Photo-T.



by Honeywell

This document is not intended to be used for installation purposes. We try to keep our product information up-to-date and accurate. We cannot cover all specific applications or anticipate all requirements. All specifications are subject to change without notice. For more information, contact Silent Knight 12 Clintonville Road, Northford, CT 06472-1610 Phone: (800) 328-0103, Fax: (203) 484-7118. For Technical Support, Please call 800-446-6444. [www.farenhyt.com](http://www.farenhyt.com)

# Farenhyt



**SILENT  
KNIGHT**

by Honeywell

Intelligent Devices

## Intelligent Thermal and Rate-of-Rise Thermal Detectors

### IDP-Heat, IDP-Heat-HT, & IDP-Heat-ROR

The IDP-Heat, IDP-Heat-HT, and IDP-Heat-ROR are plug in thermal detectors, with integral communication, that provide features that surpass conventional detectors. These thermal detectors are for use with Silent Knight IFP-series fire alarm control panels (FACPs).

Detector sensitivity can be programmed from the FACP software. Sensitivity is continuously monitored and reported to the FACP. Point ID capability allows each detector's address to be set with rotary address switches, providing exact detector locations for selective maintenance when chamber contamination reaches unacceptable levels.

IDP-Heat is a fixed temperature thermal detector that uses a thermistor sensing circuit to produce 135°F (57°C) fixed thermal detection.

IDP-Heat-HT is a variable high temperature detector that provides high temperature detection at 135°F – 190°F (57°C – 88°C).

IDP-Heat-ROR is a fixed temperature and rate-of-rise thermal detector that uses a thermistor sensing circuit to produce 135°F (57°C) thermal protection.

### Features

- Sleek, low-profile design
- Reliable analog communications for trouble-free operation
- Age resistant polymer housing
- Innovative thermistor sensing circuit
- Superior EMI resistance for reliability
- Variety of mounting options to meet any application
- Dual LED indicators for 360° visibility
- Detector transmits signal to indicate maintenance is required
- Plug-in mounting provides ease of installation
- Optional remote LED annunciator (System Sensor® PN RA100Z)
- Tamper-proof feature available on mounting bases
- Rotary address switches for fast installation
- UL Listed

### Installation

The IDP thermal detectors plug into a compatible IDP-series detector base.

### Compatibility

The IDP-Heat, IDP-Heat-HT, and IDP-Heat-ROR are compatible with the following IDP-series detector bases:

## Agency Listings



**MEA**

383-02-E Vol. VI



**IDP-Heat Installed In the B210LP Mounting Base  
(Base Not Included)**

- B210LP 6" Mounting Base
- B501 4" Mounting Base
- B224BI 6" Isolator Base
- B224RB 6" Relay Base
- B200SR Sounder Base

The IDP-Heat-HT, and IDP-Heat-ROR are compatible with the following FACPs:

- IFP-2000 / RPS-2000 Intelligent Fire Panel
- IFP-2000ECS Emergency Communication System with Fire Panel
- IFP-1000 / ECS Intelligent Fire Panel
- IFP-100 / ECS Intelligent Fire Panel
- IFP-50 Intelligent Fire Panel

The IDP-Heat is compatible with the following FACPs:

- IFP-2000 / RPS-2000 Intelligent Fire Panel
- IFP-2000ECS Emergency Communication System with Fire Panel
- IFP-1000 / ECS Intelligent Fire Panel
- IFP-100 / ECS Intelligent Fire Panel
- IFP-50 Intelligent Fire Panel
- IFP-25 Intelligent Fire Panel

P/N 350285 Rev G

Copyright © 2015 Honeywell International Inc.



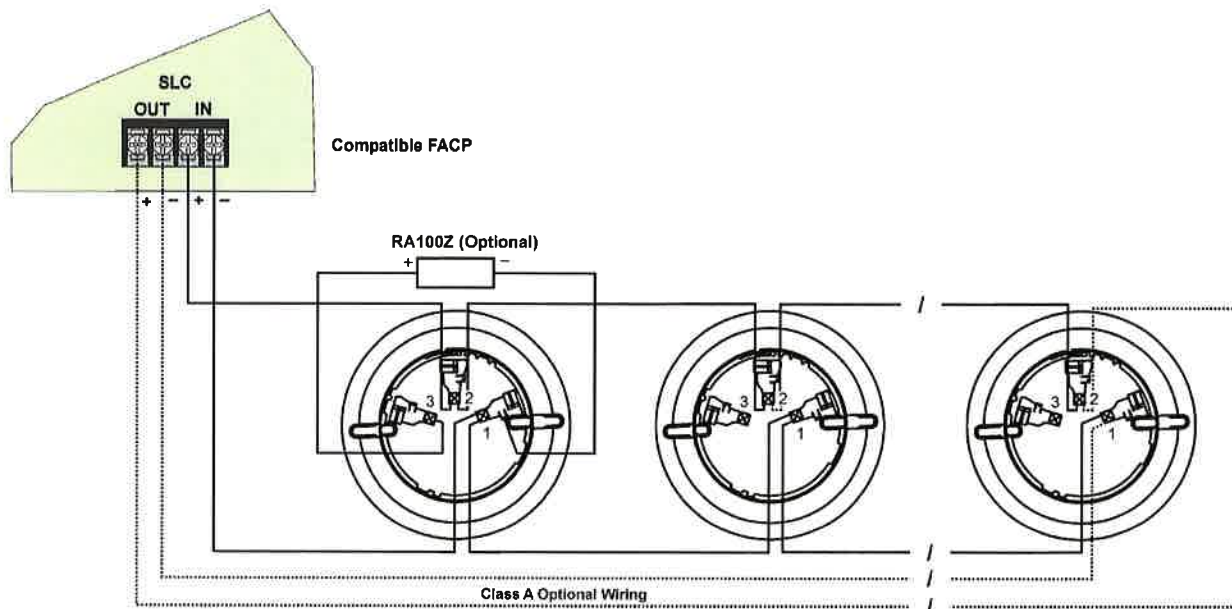

Wiring IDP-Series Detector Mounting Bases  
**Wiring IDP-Series Detector Mounting Bases**

## Specifications\*

### Physical

Height: 2.0" (5.0 cm)

Diameter: 4.1" (10.4 cm)

Shipping Weight: 4.8 oz (136 g)

### Electrical

Operating Voltage: 15 – 32 VDC

SLC Standby and Alarm Current Draw: 300 µA

### Environmental

Operating Temperature

IDP-Heat & IDP-Heat-ROR: -4° – 100°F (-20°C – 38°C)

IDP-Heat-HT: -4° – 150°F (-20°C – 66°C)

Humidity: 10% – 93% non-condensing

### Thermal Ratings

IDP-Heat: Fixed temperature setpoint 135°F (57°C)

IDP-Heat-HT: High temperature heat 135°F – 190°F (57°C – 88°C)

IDP-Heat-ROR: Rate-of-rise detection 15°F/min (9°C/min)

## Ordering Information

IDP-Heat	Fixed Temperature Thermal Detector
IDP-Heat-HT	Fixed High Temperature Thermal Detector
IDP-Heat-ROR	Fixed Temperature and Rate-of-Rise Thermal Detector

## Accessories

RA100Z	Remote LED Annunciator
XR2B	Detector Removal Tool. A removal and replacement tool for IDP plug-in detectors. Includes the T55-127-000
M02-04-00	Replacement Test Magnet.
M02-09-00	Test Magnet with Telescoping Handle
XP-4	Extension Pole for XR2B. Extends from 5 – 15 ft
T55-127-000	Detector Removal Head
BCK-200B	Black Detector Kit. For IDP-series detectors

\* Unless otherwise noted, specifications apply to all IDP thermal detectors.



**SILENT  
KNIGHT**

by Honeywell

This document is not intended to be used for installation purposes. We try to keep our product information up-to-date and accurate. We cannot cover all specific applications or anticipate all requirements. All specifications are subject to change without notice. For more information, contact Silent Knight 12 Clintonville Road, Northford, CT 06472-1610 Phone: (800) 328-0103, Fax: (203) 484-7118.

For Technical Support, Please call 800-446-6444. [www.farenhyt.com](http://www.farenhyt.com)

# Farenhyt



## Addressable Relay Module

### IDP-Relay

The IDP-Relay is an addressable relay module for use with Silent Knight IFP-series fire alarm control panels (FACPs). The

IDP-Relay allows a Silent Knight FACP to switch discrete contacts by code command. The relay contains two isolated sets of Form C contacts, which operate as a DPDT switch. No supervision is provided for the notification appliance circuit.

The IDP-Relay contacts can be used for virtually any normally open or normally closed application. Each IDP-Relay is programmed with a unique signaling line circuit (SLC) loop address. When an event occurs that controls the IDP-Relay, the relay is triggered by the FACP.

### Features

- Two sets of Form C contacts
- Contacts are rated for a variety of amps (see Specifications)
- Panel controlled status LED that flashes green in normal state and is solid red in alarm
- Relay programming is completely flexible—can be mapped to zone conditions
- Polling LED visible through the cover plate
- Attractive ivory cover plate
- Rotary address switches for fast installation
- SEMS screws for easy wiring
- UL Listed

### Relay Contact Ratings

Current Rating	Max Voltage	Load Description	Application
3 A	30 VDC	Resistive	Noncoded
2 A	30 VDC	Resistive	Coded
0.7 A	70.7 VDC	PF = 0.35	Noncoded
0.9 A	125 VAC	Resistive	Noncoded
0.46 A	30 VDC	L/R = 20 ms	Noncoded
0.5 A	125 VAC	PF = 0.75	Noncoded
0.3 A	125 VAC	PF = 0.35	Noncoded
2 A	25 VAC	PF = 0.35	Noncoded

### Agency Listings



MEA  
386-02-E Vol II

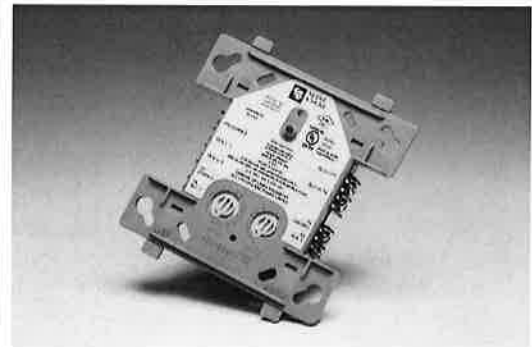

IDP-Relay

### Compatibility

The IDP-Relay is compatible with the following FACPs:

- IFP-2000 / RPS-2000 Intelligent Fire Panel
- IFP-2000ECS Emergency Communication System with Fire Panel
- IFP-1000 / ECS Intelligent Fire Panel
- IFP-100 / ECS Intelligent Fire Panel
- IFP-50 Intelligent Fire Panel
- IFP-25 Intelligent Fire Panel

### Installation

The IDP-Relay mounts directly into a 4" square electrical box. The box must have a minimum depth of 2-1/8". A surface mount electrical box (System Sensor® PN SMB500) is available from Silent Knight.

P/N 350290 Rev J

© 2015 Honeywell International Inc.

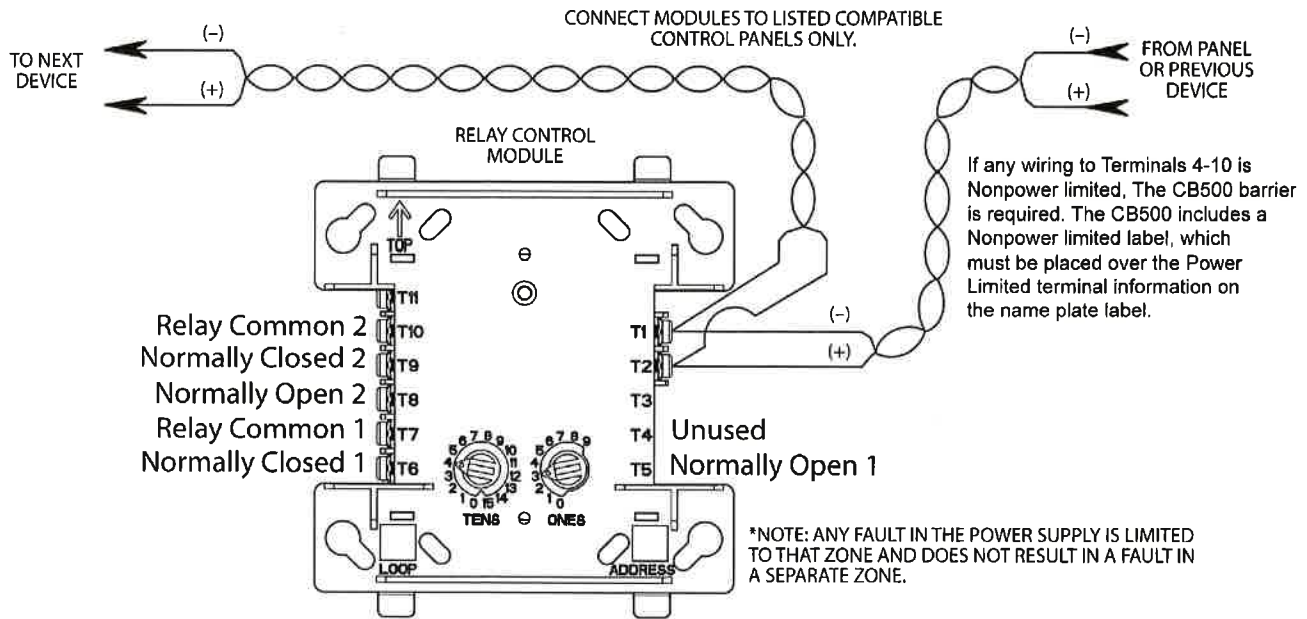

## Specifications

### Physical

4.675" H x 4.275" W x 1.4" D

Shipping Weight: 6.3 oz (196 g)

### Environmental

Operating Temperature: 32°F – 120°F (0°C – 49°C)

Humidity: 10% – 93% non-condensing

### Electrical

Operating Voltage: 15 – 32 VDC

End-of-Line Resistance: Not used

SLC Standby & Alarm Current: .255mA max @ 24 VDC  
(one communication every 5 sec with LED enabled)

## Ordering Information

IDP-Relay      Relay Module

## Accessories

SMB500      4" Square Surface Mount Electrical Box  
CB500      Module Barrier



This document is not intended to be used for installation purposes. We try to keep our product information up-to-date and accurate. We cannot cover all specific applications or anticipate all requirements. All specifications are subject to change without notice. For more information, contact Silent Knight 12 Clintonville Road, Northford, CT 06472-1610 Phone: (800) 328-0103, Fax: (203) 484-7118. For Technical Support, Please call 800-446-6444. [www.farenhyt.com](http://www.farenhyt.com)



# Farenhyt



## Advanced Multi-Criteria Fire/CO Detector IDP-FIRE-CO

The IDP-FIRE-CO is a plug-in, addressable device that provides both fire and carbon monoxide (CO) detection. For fire, the detector combines four separate sensing elements in one unit (smoke, CO, light/flame, and heat) to sense multiple components of a fire. This approach enables enhanced sensitivity to real fire with heightened immunity to nuisance particulate. For CO, the detector's electrochemical sensing cell creates a separate signal for life safety CO detection.

Released through the incomplete burning of various fuels, CO is a colorless, odorless and deadly gas that is virtually impossible to detect with the human senses. Because the potential exists for dangerous levels of CO to accumulate in almost any building, legislation mandating the use of CO detection in commercial spaces continues to increase across the U.S. and Canada. The IDP-FIRE-CO is listed to the UL 2075 standard for system-connected life safety carbon monoxide monitoring.

The IDP-FIRE-CO should be used in conjunction with the B200S/B200S-LF intelligent sounder base (sold separately), which can generate either a Temp 3 pattern for fire or a Temp 4 pattern for CO alarm indication. With each sounder base carrying a unique address, the FACP can then command an individual sounder, or a group of sounders, to activate. The command set from the panel can be tailored to the specific event, allowing selection of tone, and group. For more information on the B200S/B200S-LF refer to Data Sheet P/N 351564.

IDP-FIRE-CO can also be used with the B210LP 6" standard base, the B200SR sounder base or the B224RB relay base.

### Features

- Unique ability to detect all four major elements of a fire:
  - Smoke
  - Carbon Monoxide (CO)
  - Light/flame
  - Heat
- Separate CO detection signal
- Highest nuisance alarm immunity
- Automatic drift compensation of smoke sensor and CO cell
- Uses only one address on the SLC
- RealTest<sup>®</sup> CO testing capability
- UL 268 and UL 2075 listed
- Separates audible signal for fire or CO alarm when used with B200S/B200S-LF base
- CO cell end-of-life warning and fault

### Agency Listings



**IDP-Fire-CO**  
installed in a B200S/B200S-LF  
Sounder Base (sold separately)

### Compatibility

The IDP-FIRE-CO is compatible with the following FACP's programmed for System Sensor protocol: (Firmware version 13.0 or higher for IFP-100 & IFP-1000. Firmware version 4.0 or higher for IFP-2000).

- IFP-2000/RPS-2000 Intelligent Fire Panel
- IFP-2000ECS Emergency Communication System with Fire Alarm Control Panel
- IFP-1000 Intelligent Fire Panel
- IFP-1000ECS Emergency Communication System with Fire Alarm Control Panel
- IFP-100 Intelligent Fire Panel
- IFP-100ECS Emergency Communication System with Fire Alarm Control Panel
- IFP-50 Intelligent Fire Panel

P/N 351180 Rev F

Copyright © 2015 Honeywell International Inc.

## Specifications

### Physical

Diameter: 6.875" (17.46 cm) installed in a B200S base  
Height: 3.46" (8.79 cm) installed in B200S base  
Shipping Weight: 4.6 oz  
Color: Ivory

### Operating

Temperature Range: 32° F to 100° F (0° C to 38° C)  
Humidity: 15 to 90% relative humidity (non-condensing)  
Air Velocity: 0 to 4,000 ft/min (0 to 20 m/sec)

### Electrical

Operating Voltage: 15 to 32 VDC  
SLC Standby and Alarm Current: 300 µA

### Sensitivity Settings

Sensitivity settings are programmable through zone programming.

Low: 4% per foot (30.48 cm) of smoke. Used in equipment rooms, kitchens, paint shop.  
Medium: 3% per foot (30.48 cm) of smoke. Moderately clean environments: Used in hotel rooms, dorm rooms.  
High: 2% per foot (30.48 cm) of smoke. Clean environments: Used in offices.

**Warning:** After the CO cell has reached the end-of-life, the CO sensor no longer provides life safety protection. However, when the fire detector enters Photo, Thermal, Infrared (PTIR) mode, the following sensitivities apply:  
Level 1: 1% per foot (30.48 cm) of smoke.

Very clean environments- Used in laboratories.

Level 2: 2% per foot (30.48 cm) of smoke. Clean environments - offices.

Level 5: 3% per foot (30.48 cm) of smoke. Moderately clean environments- Used in hotel rooms, dorm rooms.

Level 6: Thermal alarm at 135° F (57° C).

### CO Monitoring UL Standard Reference - Alarm Thresholds are as follows:

Parts Per Million	Detector Response Time
70 ± 5 ppm	60-240 min.
150 ± 5 ppm	10-50 min.
400 ± 10 ppm	4-15 min.

Note: Per UL Standard 2075, the IDP-FIRE-CO has been tested to the sensitivity limits defined in UL Standard 2034.

### Ordering Information

IDP-FIRE-CO Multi-Criteria CO Detector (base not included)

*Note: Due to the unique nature of this detector, please consult your Fire Alarm Control Panel Manufacturer for the specific model and compatibility.*

### Optional Accessories

B200S Intelligent sounder base  
B200S-LF Low Frequency Intelligent sounder base  
B210LP 6" mounting base  
B200SR Sounder base  
B224RB Relay base  
M02-04-01 Detector test magnet  
M02-09-01 Telescoping test magnet



**SILENT  
KNIGHT**

by Honeywell

This document is not intended to be used for installation purposes. We try to keep our product information up-to-date and accurate. We cannot cover all specific applications or anticipate all requirements. All specifications are subject to change without notice. For more information, contact Silent Knight 12 Clintonville Road, Northford, CT 06472-1610 Phone: (800) 328-0103, Fax: (203) 484-7118.

For Technical Support, Please call 800-446-6444. [www.farenhyt.com](http://www.farenhyt.com)



## Intelligent Non-Relay Photoelectric Duct Smoke Detector

The InnovairFlex™ Series are the only duct smoke detectors flexible enough to fit configurations from square to rectangular and everything in between.

### Features

- Photoelectric, integrated low-flow technology (detector head sold separately)
- Air velocity rating from 100 ft/min to 4,000 ft/min
- Adjusts to square and rectangular mounting configurations
- Broad ranges for operating temperature (–4°F to 158°F) and humidity (0% to 95% non-condensing)
- Patented tool-free, plug-in sampling tubes
- New cover tamper signal
- Increased wiring space with a new 3/4-inch conduit knockout
- Housing has space for mounting a relay module
- Easily accessible code wheels on sensor head (sold separately)
- Clear cover for convenient visual inspection
- UL 268A listed
- Remote testing capability
- Requires com line power only
- NEMA Type 4 UL listed for non-hazardous indoor and outdoor applications (**DNRW only**)
- UV-resistant, UL-listed housing and cover material (**DNRW only**)

### Agency Listings

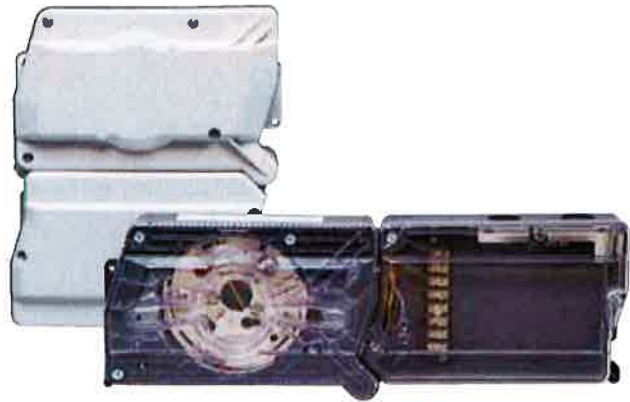

Innovairflex

The **InnovairFlex Series DNR** and **DNRW** are intelligent (addressable) non-relay photoelectric duct smoke detectors. Like all InnovairFlex detectors, the DNR and DNRW both feature an adjustable housing design that fits square and rectangular installation footprints, mounts to both round and rectangular ductwork, and utilizes tool-free, plug-in sampling tubes for increased application flexibility and installation ease.

These units sense smoke in challenging conditions, operating in airflow speeds of 100 to 4,000 feet per minute, temperatures of –4°F to 158°F, and a humidity range of 0 to 95 percent (non-condensing). For even more extreme environments like rooftops, the DNRW's NEMA 4-rated watertight and UV-resistant housing protects against windblown dirt and dust, rain, and hose directed water, enabling it to be installed without a costly enclosure, saving time and money.

The InnovairFlex housing cover isolates the sensor head from the low-flow feature for simple maintenance, and a cover tamper feature initiates a trouble signal for a removed or improperly installed sensor cover. The housing also provides a 3/4-inch conduit knockout and ample space to facilitate easy wiring and mounting of a relay module to meet specific application requirements. These detectors can be customized to meet local codes and specifications without additional wiring.

The InnovairFlex line is compatible with all previous Innovair models, including remote test accessories, for easy retrofits.

**WARNING:** Duct smoke detectors have specific limitations.

## InnovairFlex Duct Smoke Detector Specifications

### Architectural/Engineering Specifications

The air duct smoke detector shall be a System Sensor InnovairFlex™ DNR Intelligent Non-Relay Photoelectric Duct Smoke Detector and DNRW Watertight NEMA 4 Duct Smoke Detector. The detector housing shall be UL listed per UL 268A specifically for use in air handling systems. The flexible housing of the duct smoke detector fits both square and rectangular footprints. The detector shall operate at air velocities of 100 ft/min to 4,000 ft/min (0.5 m/sec to 20.32 m/sec). The unit shall be capable of providing a trouble signal in the event that the sensor cover is removed or improperly installed. It shall be capable of local testing via magnetic switch or remote testing using the RTS151KEY remote test station. Terminal connections shall be of the strip and clamp method suitable for 12–18 AWG wiring.

### Physical Specifications

**Size: (Rectangular)** 14.38 in (37 cm) Length; 5 in (12.7 cm) Width; 2.5 in (6.6 cm) Depth  
**(Square)** 7.75 in (19.7 cm) Length; 9 in (22.9 cm) Width ; 2.5 in (6.35 cm) Depth

**Weight:** 1.6 lb (0.73 kg)

**Environmental Rating:** NEMA 4 (DNRW only)

**Operating Temperature Range:** –4°F to 158°F (–20°C to 70°C)

**Storage Temperature Range:** –22°F to 158°F (–30°C to 70° C)

**Operating Humidity Range:** 0% to 95% relative humidity (non-condensing)

**Air Duct Velocity:** 100 to 4,000 ft/min (0.5 to 20.32 m/s)

**DCOIL (if included):** 17.5 – 26.4 VDC, 95 mA max

### Electrical Ratings

Please see detector head installation manual for electrical specifications

### Accessory Current Loads at 24 VDC

Device	Standby	Alarm
RA100Z	0 mA	12 mA Max.
RTS151/RTS151KEY	0 mA	12 mA Max.

## Installing the InnovairFlex Sampling Tube

The InnovairFlex sampling tube may be installed from the front or back of the detector. The tube locks securely into place and can be removed by releasing the front or rear locking tab (front locking tab shown below right).



# Wiring for Intelligent Non-Relay Duct Smoke Detector

System wiring diagram for DNR:

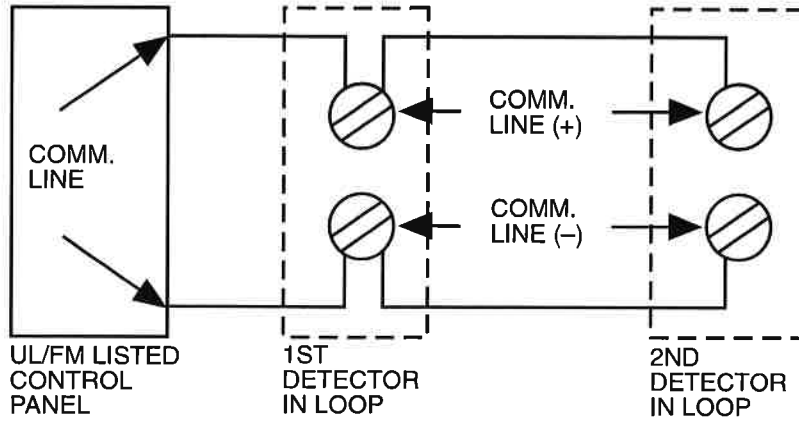

DNR to RA100Z:

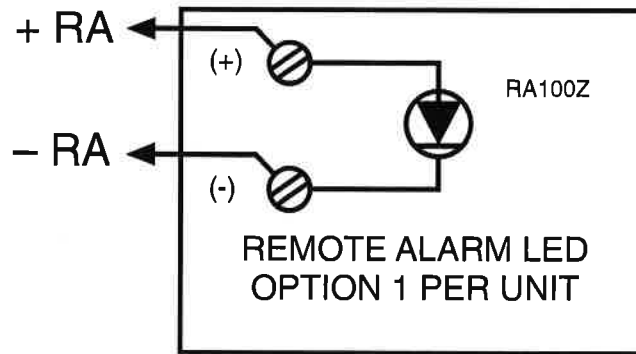

DNR to RTS151/RTS151KEY with "R" Remote Test Capable Detector Head Option:

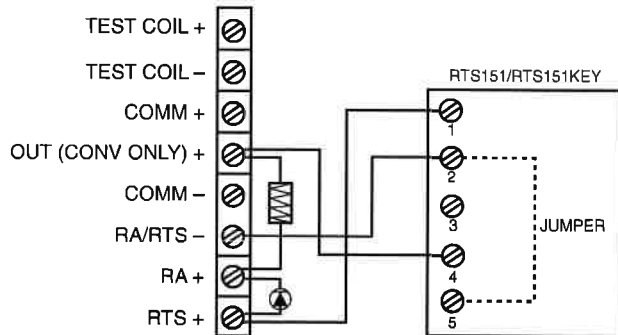

DNR to RTS151/RTS151KEY with DCOIL Option\*:

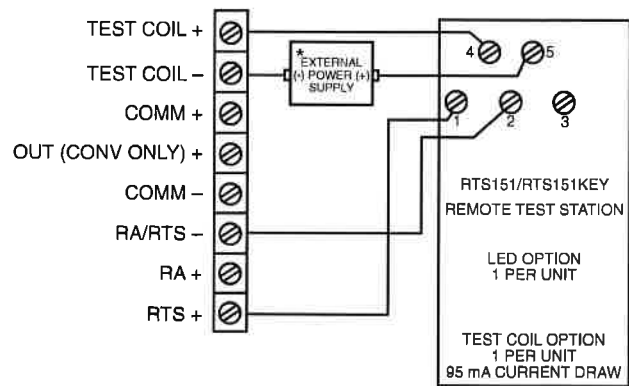

### \*Important Notes

- The use of either the RTS151 or RTS151KEY requires the installation of an accessory coil, DCOIL, sold separately. Please refer to the DNR or DNRW installation manual for more information.
- The RTS151/RTS151KEY test coil circuit requires an external 24 VDC power supply which must be UL listed.



## Accessories

System Sensor provides system flexibility with a variety of accessories, including two remote test stations and different means of visible and audible system annunciation. As with our duct smoke detectors, all duct smoke detector accessories are UL listed.



RTS151 UL S2522



RTS151KEY UL S2522



RA100Z UL S2522

## Ordering Information

Part No.	Description
DNR	Intelligent non-relay photoelectric low-flow duct smoke detector
DNRW	Watertight intelligent non-relay photoelectric low-flow duct smoke detector
<b>Accessories</b>	
DCOIL	Remote test coil required with RTS451/RTS451KEY/RTS151/RTS151KEY
DST1	Metal sampling tube duct width up to 1ft (0.3m)
DST1.5	Metal sampling tube duct widths 1 ft to 2 ft (0.3 to 0.6 m)
DST3	Metal sampling tube duct widths 2 ft to 4 ft (0.6 to 1.2 m)
DST5	Metal sampling tube duct widths 4 ft to 8 ft (1.2 to 2.4 m)
DST10	Metal sampling tube duct widths 8 ft to 12 ft (2.4 to 3.7 m)
P48-21-00	End cap for metal sampling tubes
ETX	Metal exhaust tube duct width 1ft (0.3 m)
M02-04-00	Test magnet
RA100Z	Remote annunciator alarm LED
RTS151	Remote test station
RTS151KEY	Remote test station with key lock
DH4000E-1	Weatherproof enclosure



3825 Ohio Avenue • St. Charles, IL 60174  
Phone: 800-SENSOR2 • Fax: 630-377-6495

©2010 System Sensor  
Product specifications subject to change without notice. Visit [systemsensor.com](http://systemsensor.com) for  
current product information, including the latest version of this data sheet  
A05-0422-005 - 9/10 - #2470

# Farenhyt



**SILENT  
KNIGHT**

by Honeywell  
Intelligent Devices

## Intelligent Photoelectric Smoke Detector & Photoelectric Smoke with Thermal

### IDP-Photo, IDP-Photo-T and IDP-PhotoR

The IDP-Photo is a photoelectric smoke detector and the IDP-Photo-T is a photoelectric smoke detector with thermal. These plug in smoke detectors, with integral communication, provide features that surpass conventional detectors and are for use with Silent Knight IFP-series fire alarm control panels (FACPs).

Detector sensitivity can be programmed from the FACP software. Sensitivity is continuously monitored and reported to the FACP. Point ID capability allows each detector's address to be set with rotary address switches, providing exact detector locations for selective maintenance when chamber contamination reaches unacceptable levels.

IDP-Photo and IDP-Photo-T have a unique optical sensing chamber that is engineered to sense smoke produced by a wide range of combustion sources. In the IDP-Photo-T, dual electronic thermistors add 135°F (57°C) thermal technology to maximize detection.

The IDP-PhotoR is a remote test capable detector for use with the DNR (W) duct smoke detectors. It is UL 268A listed when used with the DNR (W) duct smoke detector.

### Features

- Sleek, low-profile design
- Reliable analog communications for trouble-free operation
- Age resistant polymer housing
- Dual electronic thermistor design on the IDP-Photo-T
- Superior EMI resistance for reliability
- Simple field cleaning for code compliance
- Variety of mounting options to meet any application
- Dual LED indicators for 360° visibility
- Detector transmits signal to indicate maintenance is required
- Optional remote LED annunciator (System Sensor® PN RA100Z)
- Plug-in mounting provides ease of installation
- Tamper-proof feature available on mounting bases
- Listed for use in duct applications
- Rotary address switches for fast installation
- UL Listed



**MEA**  
225-02-E Vol. V



IDP-Photo (Base not included)

### Installation

The IDP-Photo and IDP-Photo-T plug into a compatible IDP-series detector base. The IDP-PhotoR is a remote test capable detector for use with the DNR (W) duct smoke detector.

### Compatibility

The IDP-Photo, IDP-Photo-T and IDP-PhotoR are compatible with the following IDP-series detector bases:

- B210LP 6" Mounting Base
- B501 4" Mounting Base
- B224BI 6" Isolator Base
- B224RB 6" Relay Base
- B200SR 6" Sounder Base

The IDP-Photo, IDP-Photo-T and IDP-PhotoR are compatible with the following FACPs:

- IFP-2000 / RPS-2000 Intelligent Fire Panel
- IFP-2000ECS Emergency Communication System with Fire Panel
- IFP-1000 / ECS Intelligent Fire Panel
- IFP-100 / ECS Intelligent Fire Panel
- IFP-50 Intelligent Fire Panel
- IFP-25 Intelligent Fire Panel

P/N 350280 Rev H

Copyright © 2017 Honeywell International Inc.

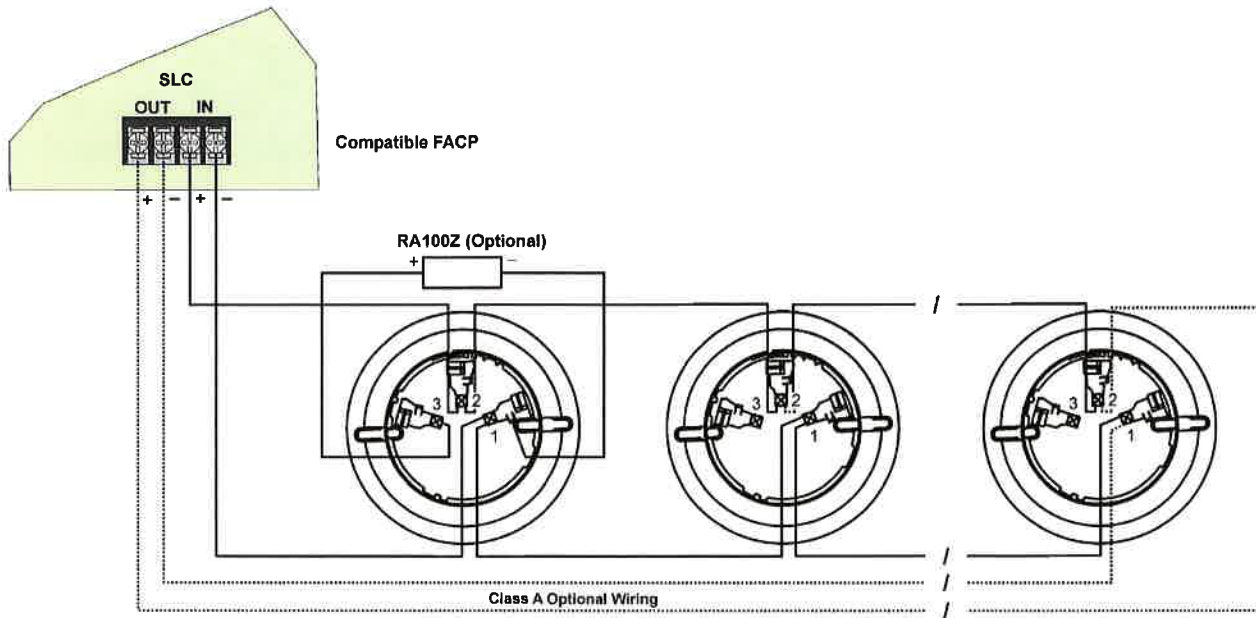

Wiring IDP-Series Detector Mounting Bases

## Wiring IDP-Series Detector Mounting Bases

### Specifications\*

#### Physical

Height: 2.0" (5.0 cm)

Diameter: 4.1" (10.4 cm) installed in B501 base

#### Electrical

Operating Voltage: 15–32 VDC

SLC Standby and Alarm Current: 300  $\mu$ A

#### Environmental

Operating Temperature

IDP-Photo: 32° – 120°F (0°C – 49°C)

IDP-Photo-T: 32° – 100°F (0°C – 38°C)

Humidity: 10% – 93% non-condensing

#### Other Ratings

IDP-Photo-T Thermal: Fixed temperature setpoint 135°F (57°C)

Velocity: 0 – 4000 fpm (0 – 20 m/sec) (suitable for installation in ducts)

IDP-Photo Insect Screen Hole Size: 0.016" (0.41 mm) nominal

### Ordering Information

IDP-Photo	Photoelectric Smoke Detector
IDP-Photo-T	Photoelectric Smoke Detector with Thermal (135°F)
IDP-PhotoR	Photoelectric smoke detector, remote test capable, for use with DNR (W) duct smoke detector

### Accessories

RA100Z	Remote LED Annunciator.
XR2B	Detector Removal Tool. A removal and replacement tool for IDP plug-in detectors. Includes the T55-127-000.
M02-04-01	Detector Test Magnet.
M02-09-00	Test Magnet with Telescoping Handle.
XP-4	Extension Pole for XR2B. Extends from 5 – 15 ft.
T55-127-000	Detector Removal Head.
BCK-200B	Black Detector Kit. For IDP-series detectors.

\* Unless otherwise noted, specifications apply to IDP-Photo and IDP-Photo-T.



by Honeywell

This document is not intended to be used for installation purposes. We try to keep our product information up-to-date and accurate. We cannot cover all specific applications or anticipate all requirements. All specifications are subject to change without notice. For more information, contact Silent Knight 12 Clintonville Road, Northford, CT 06472-1610 Phone: (800) 328-0103, Fax: (203) 484-7118. For Technical Support, Please call 800-446-6444. [www.farenhyt.com](http://www.farenhyt.com)

# Farenhyt



**SILENT  
KNIGHT**

by Honeywell

Intelligent Device

## Addressable Monitor Module

### IDP-Monitor

The IDP-Monitor is an addressable monitor module for use with Silent Knight IFP-series fire alarm control panels (FACPs). The IDP-Monitor acts as an interface to contact devices, such as waterflow switches and pull stations.

The IDP-Monitor supports Class A supervised or Class B supervised wiring to the load device. Conventional 4-wire smoke detectors can be monitored for alarm and trouble conditions.

### Features

- Single contact monitor
- Support for Class A and Class B wiring
- Fully supervised
- Panel controlled status LED that flashes green in normal state and is solid red in alarm
- Attractive ivory cover plate
- Rotary address switches for fast installation
- SEMS screws for easy wiring
- UL Listed

### Installation

The IDP-Monitor mounts directly into a 4" square electrical box. The box must have a minimum depth of 2-1/8". A surface mount electrical box (System Sensor® PN SMB500) is available from Silent Knight.

## Agency Listings



**MEA**  
386-0-E-Vol 2

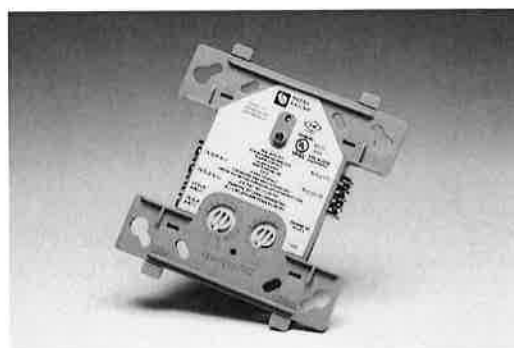

**IDP-Monitor**

## Compatibility

The IDP-Monitor is compatible with the following FACPs:

- IFP-2000 / RPS-2000 Intelligent Fire Panel
- IFP-2000ECS Emergency Communication System with Fire Panel
- IFP-1000 / ECS Intelligent Fire Panel
- IFP-100 / ECS Intelligent Fire Panel
- IFP-50 Intelligent Fire Panel

P/N 350288 Rev J

Copyright © 2015 Honeywell International Inc.

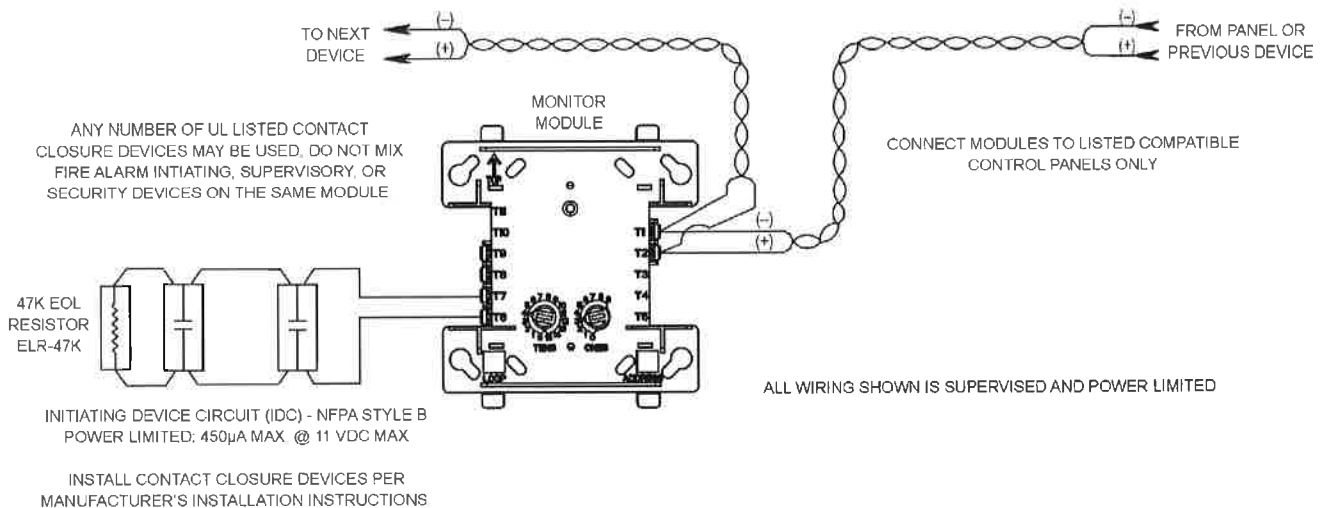

Typical Wiring for IDP-Monitor Module, NFPA Style B

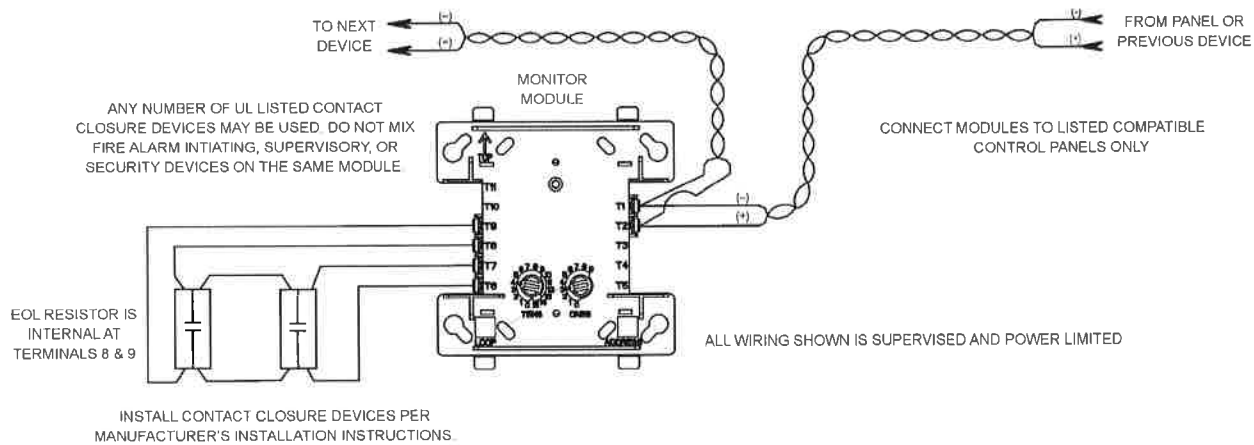

Typical Wiring for IDP-Monitor Module, NFPA Style D

## Specifications

### Physical

Height: 4.5" (11.4 cm)

Width: 4" (10.2 cm)

Depth: 1.25" (3 cm)

Shipping Weight: 6.3 oz (196 g)

### Electrical

Operating Voltage: 15 – 32 VDC

SLC Standby and Alarm Current Draw: 350 µA

End-of-Line Resistance: 47K Ω

Max. IDC wiring resistance: 1,500 Ω

Max. IDC Voltage: 11 Volts

Max. IDC Current: 450 µA

SLC Loop Resistance: 40 Ω max.

### Environmental

Operating Temperature: 32°F – 120°F (0°C – 49°C)

Humidity: 10% – 93% non-condensing

### Ordering Information

IDP-Monitor      Monitoring Module

### Accessories

SMB500      4" Square Surface Mount Electrical Box



**SILENT  
KNIGHT**

by Honeywell

This document is not intended to be used for installation purposes. We try to keep our product information up-to-date and accurate. We cannot cover all specific applications or anticipate all requirements. All specifications are subject to change without notice. For more information, contact Silent Knight 12 Clintonville Road, Northford, CT 06472-1610 Phone: (800) 328-0103, Fax: (203) 484-7118.

For Technical Support, Please call 800-446-6444. [www.farenhyt.com](http://www.farenhyt.com)



## Indoor Selectable-Output Horns, Strobes, and Horn Strobes for Wall Applications

*System Sensor L-Series audible visible notification products are rich with features guaranteed to cut installation times and maximize profits with lower current draw and modern aesthetics.*

### Features

- Updated Modern Aesthetics
- Small profile devices for Horns and Horn Strobes
- Plug-in design with minimal intrusion into the back box
- Tamper-resistant construction
- Automatic selection of 12- or 24-volt operation at 15 and 30 candela
- Field-selectable candela settings on wall units: 15, 30, 75, 95, 110, 135, and 185
- Horn rated at 88+ dBA at 16 volts
- Rotary switch for horn tone and two volume selections
- Mounting plate for all standard and all compact wall units
- Mounting plate shorting spring checks wiring continuity before device installation
- Electrically Compatible with legacy SpectrAlert and SpectAlert Advance devices
- Compatible with MDL3 sync module
- Listed for wall mounting only

### Agency Listings



FM approved except  
for ALERT models  
3057363, 3057072



7125-1853 18104  
7125-1853 0500



**The System Sensor L-Series** offers the most versatile and easy-to-use line of horns, strobes, and horn strobes in the industry with lower current draws and modern aesthetics. With white and red plastic housings, standard and compact devices, and plain, FIRE, and FUEGO-printed devices, System Sensor L-Series can meet virtually any application requirement.

The L-Series line of wall-mount horns, strobes, and horn strobes include a variety of features that increase their application versatility while simplifying installation. All devices feature plug-in designs with minimal intrusion into the back box, making installations fast and foolproof while virtually eliminating costly and time-consuming ground faults.

To further simplify installation and protect devices from construction damage, the L-Series utilizes a universal mounting plate for all models with an onboard shorting spring, so installers can test wiring continuity before the device is installed.

Installers can also easily adapt devices to suit a wide range of application requirements using field-selectable candela settings, automatic selection of 12- or 24-volt operation, and a rotary switch for horn tones with two volume selections.

## L-Series Specifications

### Architect/Engineer Specifications

#### General

L-Series standard horns, strobes, and horn strobes shall mount to a standard 2 x 4 x 1 7/8-inch back box, 4 x 4 x 1 1/2-inch back box, 4-inch octagon back box, or double-gang back box. L-Series compact products shall mount to a single-gang 2 x 4 x 1 7/8-inch back box. A universal mounting plate shall be used for mounting ceiling and wall products for all standard models and a separate universal mounting plate shall be used for mounting wall compact models. The notification appliance circuit wiring shall terminate at the universal mounting plate. Also, L-Series products, when used with the Sync•Circuit™ Module accessory, shall be powered from a non-coded notification appliance circuit output and shall operate on a nominal 12 or 24 volts. When used with the Sync•Circuit Module, 12-volt-rated notification appliance circuit outputs shall operate between 8.5 and 17.5 volts; 24-volt-rated notification appliance circuit outputs shall operate between 16.5 and 33 volts. Indoor L-Series products shall operate between 32 and 120 degrees Fahrenheit from a regulated DC or full-wave rectified unfiltered power supply. Strobes and horn strobes shall have field-selectable candela settings including 15, 30, 75, 95, 110, 135, and 185.

#### Strobe

The strobe shall be a System Sensor L-Series Model \_\_\_\_\_ listed to UL 1971 and shall be approved for fire protective service. The strobe shall be wired as a primary-signaling notification appliance and comply with the Americans with Disabilities Act requirements for visible signaling appliances, flashing at 1 Hz over the strobe's entire operating voltage range. The strobe light shall consist of a xenon flash tube and associated lens/reflector system.

#### Horn Strobe Combination

The horn strobe shall be a System Sensor L-Series Model \_\_\_\_\_ listed to UL 1971 and UL 464 and shall be approved for fire protective service. The horn strobe shall be wired as a primary-signaling notification appliance and comply with the Americans with Disabilities Act requirements for visible signaling appliances, flashing at 1 Hz over the strobe's entire operating voltage range. The strobe light shall consist of a xenon flash tube and associated lens/reflector system. The horn shall have two audibility options and an option to switch between a temporal three pattern and a non-temporal (continuous) pattern. These options are set by a multiple position switch. The horn on horn strobe models shall operate on a coded or non-coded power supply.

#### Synchronization Module

The module shall be a System Sensor Sync•Circuit model MDL3 listed to UL 464 and shall be approved for fire protective service. The module shall synchronize SpectrAlert strobes at 1 Hz and horns at temporal three. Also, while operating the strobes, the module shall silence the horns on horn strobe models over a single pair of wires. The module shall mount to a 4 1/16 x 4 1/16 x 2 1/8-inch back box. The module shall also control two Style Y (class B) circuits or one Style Z (class A) circuit. The module shall synchronize multiple zones. Daisy chaining two or more synchronization modules together will synchronize all the zones they control. The module shall not operate on a coded power supply.

### Physical/Electrical Specifications

<b>Standard Operating Temperature</b>	32°F to 120°F (0°C to 49°C)
<b>Humidity Range</b>	10 to 93% non-condensing
<b>Strobe Flash Rate</b>	1 flash per second
<b>Nominal Voltage</b>	Regulated 12 DC or regulated 24 DC/FWR <sup>1,2</sup>
<b>Operating Voltage Range</b>	8 to 17.5 V (12 V nominal) or 16 to 33 V (24 V nominal)
<b>Operating Voltage Range MDL3 Sync Module</b>	8.5 to 17.5 V (12 V nominal) or 16.5 to 33 V (24 V nominal)
<b>Input Terminal Wire Gauge</b>	12 to 18 AWG
<b>Wall-Mount Dimensions (including lens)</b>	5.6" L x 4.7" W x 1.91" D (143 mm L x 119 mm W x 49 mm D)
<b>Compact Wall-Mount Dimensions (including lens)</b>	5.26" L x 3.46" W x 1.91" D (133 mm L x 88 mm W x 49 mm D)
<b>Horn Dimensions</b>	5.6" L x 4.7" W x 1.25" D (143 mm L x 119 mm W x 32 mm D)
<b>Compact Horn Dimensions</b>	5.25" L x 3.45" W x 1.25" D (133mm L x 88mm W x 32mm D)

1. Full Wave Rectified (FWR) voltage is a non-regulated, time-varying power source that is used on some power supply and panel outputs.

2. Strobe products will operate at 12 V nominal only for 15 cd and 30 cd.

## UL Current Draw Data

UL Max. Strobe Current Draw (mA RMS)				
Candela Range	Candela	8-17.5 Volts		16-33 Volts
		DC	DC	FWR
Candela Range	15	88	43	60
	30	143	63	83
	75	N/A	107	136
	95	N/A	121	155
	110	N/A	148	179
	135	N/A	172	209
	185	N/A	222	257

UL Max. Horn Current Draw (mA RMS)				
Sound Pattern	dB	8-17.5 Volts		16-33 Volts
		DC	DC	FWR
Temporal	High	39	44	54
Temporal	Low	28	32	54
Non-Temporal	High	43	47	54
Non-Temporal	Low	29	32	54
3.1 KHz Temporal	High	39	41	54
3.1 KHz Temporal	Low	29	32	54
3.1 KHz Non-Temporal	High	42	43	54
3.1 KHz Non-Temporal	Low	28	29	54
Coded	High	43	47	54
3.1 KHz Coded	High	42	43	54

UL Max. Current Draw (mA RMS), 2-Wire Horn Strobe, Candela Range (15-115 cd)										
DC Input	8-17.5 Volts		16-33 Volts							
	15cd	30cd	15cd	30cd	75cd	95cd	110cd	135cd	185cd	
Temporal High	98	158	54	74	121	142	162	196	245	
Temporal Low	93	154	44	65	111	133	157	184	235	
Non-Temporal High	106	166	73	94	139	160	182	211	262	
Non-Temporal Low	93	156	51	71	119	139	162	190	239	
3.1K Temporal High	93	156	53	73	119	140	164	190	242	
3.1K Temporal Low	91	154	45	66	112	133	160	185	235	
3.1K Non-Temporal High	99	162	69	90	135	157	175	208	261	
3.1K Non-Temporal Low	93	156	52	72	119	138	162	192	242	
16-33 Volts										
FWR Input	15cd	30cd	75cd	95cd	110cd	135cd	185cd			
Temporal High	83	107	156	177	198	234	287			
Temporal Low	68	91	145	165	185	223	271			
Non-Temporal High	111	135	185	207	230	264	316			
Non-Temporal Low	79	104	157	175	197	235	283			
3.1K Temporal High	81	105	155	177	196	234	284			
3.1K Temporal Low	68	90	145	166	186	222	276			
3.1K Non-Temporal High	104	131	177	204	230	264	326			
3.1K Non-Temporal Low	77	102	156	177	199	234	291			

## Horn Tones and Sound Output Data

Horn and Horn Strobe Output (dBA)					
Switch Position	Sound Pattern	dB	8-17.5 Volts	16-33 Volts	FWR
			DC	DC	
1	Temporal	High	84	89	89
2	Temporal	Low	75	83	83
3	Non-Temporal	High	85	90	90
4	Non-Temporal	Low	76	84	84
5	3.1 KHz Temporal	High	83	88	88
6	3.1 KHz Temporal	Low	76	82	82
7	3.1 KHz Non-Temporal	High	84	89	89
8	3.1 KHz Non-Temporal	Low	77	83	83
9*	Coded	High	85	90	90
10*	3.1 KHz Coded	High	84	89	89

\* Settings 9 and 10 are not available on the 2-wire horn strobes.



## L-Series Dimensions

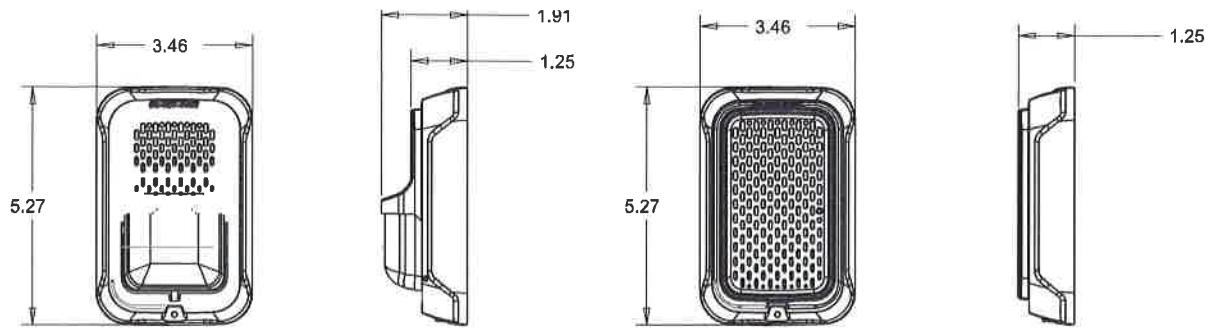

Compact Strobe / Horn Strobe

Compact Horn

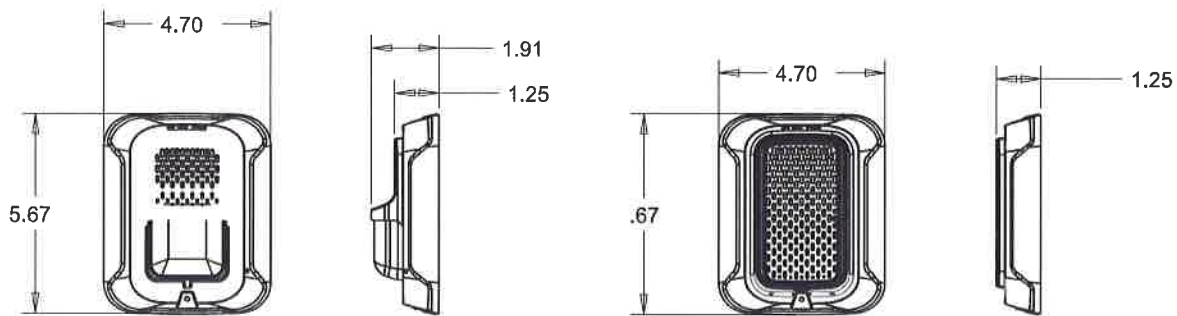

Strobe / Horn Strobe

Horn

## L-Series Ordering Information

Model	Description
<b>Wall Horn Strobes</b>	
P2RL	2-Wire, Horn Strobe, Red
P2WL	2-Wire, Horn Strobe, White
P2GRL	2-Wire, Compact Horn Strobe, Red
P2GWL	2-Wire, Compact Horn Strobe, White
P2RL-P	2-Wire, Horn Strobe, Red, Plain
P2WL-P	2-Wire, Horn Strobe, White, Plain
P2RL-SP	2-Wire, Horn Strobe, Red, FUEGO
P2WL-SP	2-Wire, Horn Strobe, White, FUEGO
<b>Wall Strobes</b>	
SRL	Strobe, Red
SWL	Strobe, White
SGRL	Compact Strobe, Red
SGWL	Compact Strobe, White
SRL-P	Strobe, Red, Plain
SWL-P	Strobe, White, Plain
SRL-SP	Strobe, Red, FUEGO
SWL-CLR-ALERT	Strobe, White, ALERT

Model	Description
<b>Horns</b>	
HRL	Horn, Red
HWL	Horn, White
HGRL	Compact Horn, Red
HGWL	Compact Horn, White
<b>Accessories</b>	
TR-2	Universal Wall Trim Ring Red
TR-2W	Universal Wall Trim Ring White
SBBRL	Wall Surface Mount Back Box, Red
SBBWL	Wall Surface Mount Back Box, White
SBBGRL	Compact Wall Surface Mount Back Box, Red
SBBGWL	Compact Wall Surface Mount Back Box, White

### Notes:

All -P models have a plain housing (no "FIRE" marking on cover)  
 All -SP models have "FUEGO" marking on cover  
 All -ALERT models have "ALERT" marking on cover



3825 Ohio Avenue • St. Charles, IL 60174  
 Phone: 800-SENSOR2 • Fax: 630-377-6495  
[www.systemsensor.com](http://www.systemsensor.com)

©2017 System Sensor.  
 Product specifications subject to change without notice. Visit [systemsensor.com](http://systemsensor.com)  
 for current product information, including the latest version of this data sheet.  
 AVDS86503 • 03/17

**ENVIROALERT®****DUAL ZONE CRITICAL CONDITION MONITORING OF TEMPERATURE, HUMIDITY AND WATER**

- Simultaneously monitor 2 zones (has 1 on-board ambient temp sensor, accepts 1 remote sensor).
- Monitor for temperature, humidity, or water presence.
- Graphic LCD data display that flashes under alarm condition.
- User-friendly configuration set up with tamper proof lock.
- 2 zone-specific relays plus 1 auxiliary relay.
- Auxiliary alarm silence feature with 10 minute timer.
- Alarm time delay up to 120 minutes to avoid nuisance alarms (excellent for freezer defrost cycles)
- Temperature and humidity high/low set points.

**EA200-12****EA200-24****Specifications**

Power requirements	12VDC @ < 200mA	24VDC @ < 200mA
Remote Sensor Inputs	1 (1 on-board sensor)	
Unit Operating Range	32 to 122° F (0 to 50° C)	

Power requirements	12VDC @ < 200mA	24VDC @ < 200mA
Low & High Limit Adjust Range	-58 to 299° F (-50 to 150° C)	
Alarm Outputs	2 - SPDT Relays (1A @ 30 VDC) configurable	
Auxiliary Alarm Output	1 - SPDT Relay - non-configurable	
Weight	.55 lb (0.25 kg)	
Dimensions	6 x 4.75 x 1.25" (15.24 x 12.07 x 3.18 cm)	
Mounting	Standard 2-gang box or surface mount	

## Consoles and Accessory Sensors

Console	Model Number	Voltage
EnviroAlert	EA200-12	12 V
EnviroAlert	EA200-24	24V
Sensor Detection	Model Number	Range
Temp Low (Blue) Stainless Steel	TEMP-L-S	-58° to 158° F (-50 to 70° C)
Temp Low (Blue) Waterproof	TEMP-L-W	-58° to 158° F (-50 to 70° C)
Temp High (Red) Stainless Steel	TEMP-H-S	32° to 299° F (0 to 150° C)
Temp High (Red) Waterproof	TEMP-H-W	32° to 221° F (0 to 105° C)
Humidity*	HAIH+	5% to 95% RH
Water Surface Sensor (supervised)	W-S-S	Wet/Dry
Water Under Carpet (supervised)	W-UC-S	Wet/Dry



Visit [www.winland.com](http://www.winland.com), call 800.635.4269 or email [info@winland.com](mailto:info@winland.com) to learn more.

