

MECHANICAL GAS VALVE
- INSTALLATION BEFORE
FIRST APPLIANCE

(3) 16" FRYERS 24"x24" GRIDDLE 24"x24" GRIDDLE 24"x24" GRIDDLE 24"x24" GRIDDLE

Reviewed For Code Compliance By:
16" INDUCTION RANGE D. Banks Wallace
Chief Deputy Fire Marshal
04/15/2019 4:25:07 PM

REMOTE PULL STATION

SHALL BE INSTALLED 42" - 48" ABOVE THE FINISHED FLOOR AND A DISTANCE OF AT LEAST 10FT FROM THE HAZARD BUT NOT MORE THAN 20FT. IT SHALL BE INSTALLED IN THE PATH OF EXIT AND REQUIRE A MAXIMUM FORCE OF 40 LBS AND A MAXIMUM MOVEMENT OF 14" FOR ACTUATION

CLASS K WET CHEMICAL EXTINGUISHER

SHALL BE INSTALLED 42" - 48" ABOVE THE FINISHED FLOOR - 10' to 30' FROM THE HAZARD

ANSUL R102 – 9 GALLON SYSTEM
TANK 1 USES 10 of 11 FLOW POINTS
TANK 2 USES 5 of 11 FLOW POINTS
TANK 3 USES 8 of 11 FLOW POINTS

SYSTEM PIPING LIMITATIONS

9 GALLON SYSTEM PER TANK				
Requirments	Supply	Duct Branch	Plenum Branch	Appliance Branch
Pipe Size	3/8"	3/8"	3/8"	3/8"
Maximum Length	40 FT	8 FT	4 FT	12 FT
Maximum Rise	6 FT	4 FT	2 FT	2 FT
Max 90 Elbow	9	4	4	6
Max Tees	1	2	2	4
Max Flow Points	11	4	2	4



Johnson Controls Fire Protection
540 Civic Blvd #105
Raleigh, NC 27610

BISCUITVILLE
1608 NC HWY 24/87
CAMERON NC 28326

SIZE	DWG #	DWG	REV
		KITCHEN FIRE SYSTEM	1
SCALE	N/A	SHEET	1 OF 5

GENERAL NOTES:

1. System shall be Pre-Engineered
2. System shall be manufactured by ANSUL INC.
3. ANSUL R102 systems have the following Listings and Approvals:

Underwriters Laboratories Inc, UL 300 / UL 1254, UL EX 3470
4. System Temperature Limitations – 32F min / 120F Max
5. Installation requirements, nozzle limitations and design criteria shall comply with the ANSUL R102 Manual and all addendums as published by ANSUL
6. Pipe and fittings shall be Schedule 40 Black, Chrome Plated or Stainless. Galvanized Pipe Shall Not Be Used.
7. All required electrical work shall be performed by others and is not included on this shop drawing.
8. All required plumbing work be performed by others and is not included on this shop drawing

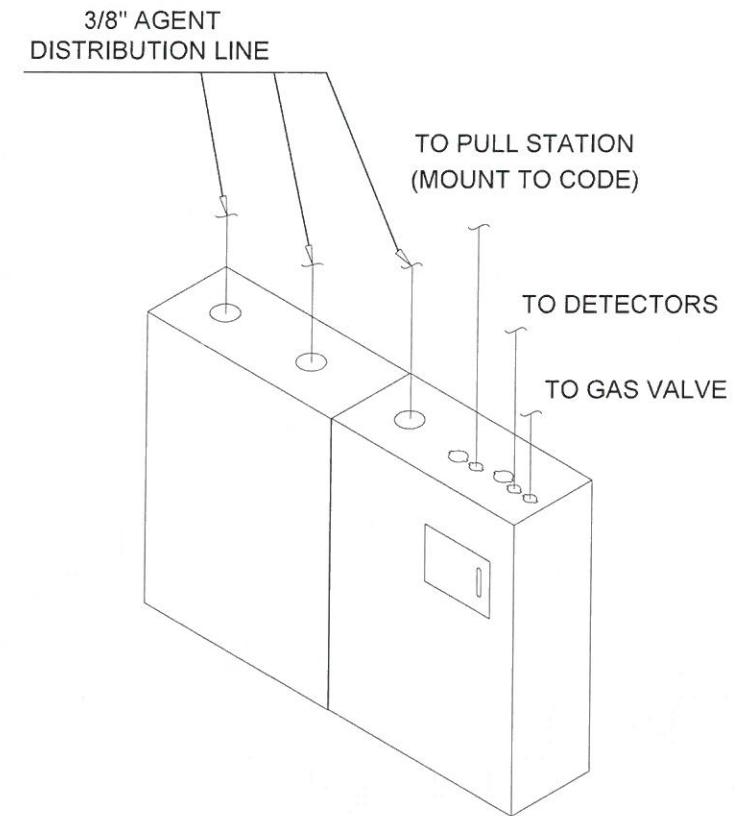

9 GAL. SYSTEM DETAIL
N.T.S.

General Piping Requirements

1. All R-102 system piping is straight line. Therefore, the need for critical lengths and balancing is minimized.
2. Two 45° elbows count as one 90° elbow.
3. Each branch line includes the tee or elbow leading to it, and all fittings within the branch line itself.
4. The minimum piping length of Schedule 40, 3/8 in. pipe from the tank outlet to any nozzle protecting a range, fryer, or wok must be 6 ft. (1.8 m).
5. Pipe lengths are measured from center of fitting to center of fitting. See Figure 85.

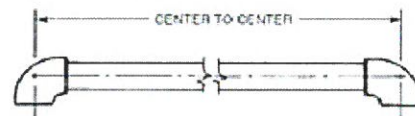

FIGURE 85

6. All distribution piping must be 3/8 in. Schedule 40 black iron, chrome-plated, or stainless steel. **Do not use hot dipped galvanized pipe on the distribution piping.**
7. All threaded connections located in and above the protected area must be sealed with pipe tape. Tape should be applied to male threads only. Make certain tape does not extend over the end of the thread, as this could cause possible blockage of the agent distribution.
8. Before installing blow-off caps on nozzles, apply a small amount of Dow Corning No. 111 silicone grease across the opening in the nozzle tip and also a small amount coating the exterior of the blow-off cap. This will help keep cooking grease from building up on the cap.
9. Tees used in the distribution piping can be used as thru tees, side outlet tees, or bull tees.

TANK AND CARTRIDGE REQUIREMENTS

Once the hazard analysis is completed and the total nozzle flow numbers are established, the quantity and size of agent tanks and cartridges needed to supply the nozzles with the proper volumes of agent at the proper flow rates can be determined. For cartridges used in the regulated release mechanism, flow capacities, tank quantities and sizes, and regulated release cartridge options are given in the table below.

Total Flow Numbers*	Quantity and Size of Tank(s)	Regulated Release Cartridge Options	
		Nitrogen	Carbon Dioxide
1 – 5	(1) 1.5 Gallon	LT-20-R	101-10
6 – 11	(1) 3.0 Gallon	LT-30-R	101-20
11 – 16	(1) 1.5 Gallon (1) 3.0 Gallon	Double	101-30
16 – 22	(2) 3.0 Gallon	Double	101-30**
16 – 22	(2) 3.0 Gallon (Manifold)	Double	–
22 – 33	(3) 3.0 Gallon	Double	–

When one or more regulated actuators are used, the following tank and cartridge combinations apply for each regulated actuator:

Regulated Actuator Tank(s)	Regulated Actuator Cartridge
(1) 1.5 Gallon	LT-20-R or 101-10
(1) 3.0 Gallon	LT-30-R or 101-20
(1) 1.5 Gallon and (1) 3.0 Gallon	LT-A-101-30 or 101-30** or double tank
(2) 3.0 Gallon	LT-A-101-30 or 101-30** or double tank
(2) 3.0 Gallon (Manifold)	LT-A-101-30 or Double
(3) 3.0 Gallon	LT-A-101-30 or Double

	Johnson Controls Fire Protection 540 Civic Blvd #105 Raleigh, NC 27610		
	BISCUITVILLE 1608 NC HWY 24/87 CAMERON NC 28326		
SIZE	DWG #	DWG	REV
		KITCHEN FIRE SYSTEM	1
SCALE	N/A	SHEET	2 OF 5

HORIZONTAL PROTECTION – OPTION 1

1N NOZZLE – PART NO. 419335 – SINGLE BANK PROTECTION

One 1N nozzle will protect 10 linear feet (3.1 m) of single filter bank plenum. The nozzle(s) must be mounted in the plenum, 2 to 4 in. (5 to 10 cm) from the face of the filter, centered between the filter height dimension, and aimed down the length. The nozzle must be positioned 0-6 in. (0-15 cm) from the end of the hood to the tip of the nozzle. See Figure 9.

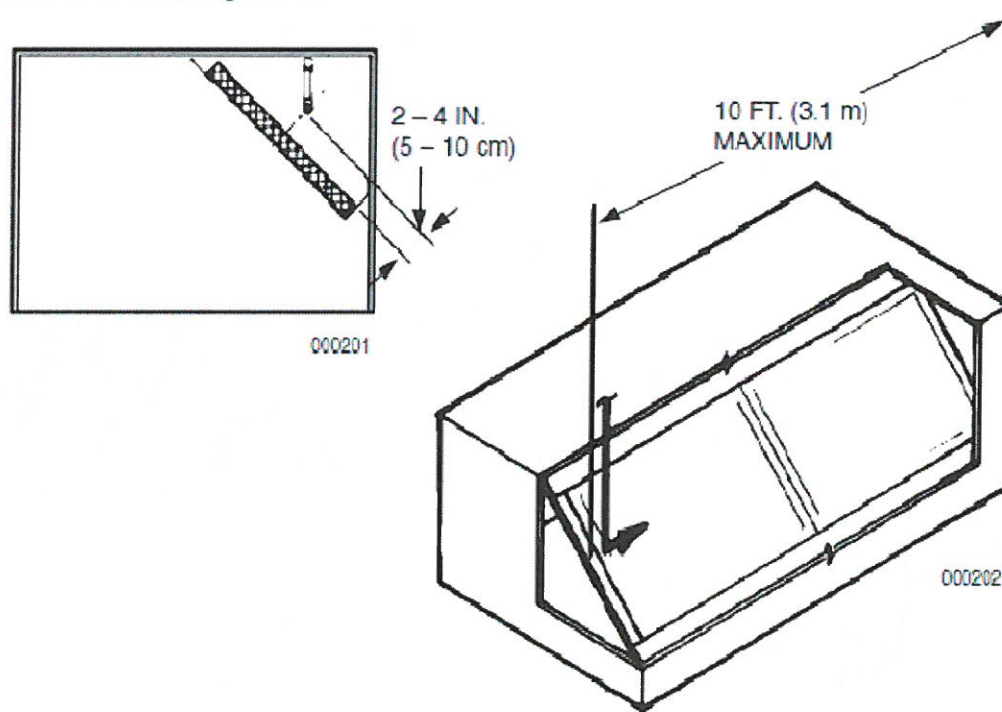

DUCT PROTECTION

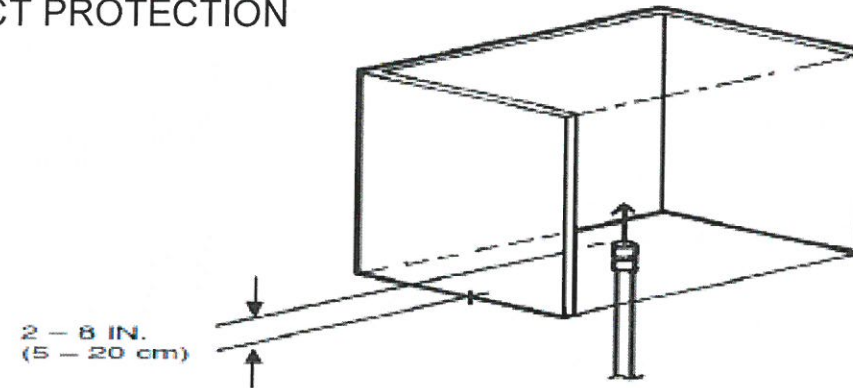

DUCT SIZES UP TO 50 IN. (127 cm)
PERIMETER/ 16 IN. (41 cm) DIAMETER

- One 1W nozzle (Part No. 419336) = one flow number
- 50 in. (127 cm) perimeter maximum
- 16 in. (41 cm) diameter maximum

DUCT SIZES UP TO 100 IN. (254 cm)
PERIMETER/ 32 IN. (81.3 cm) DIAMETER

- One 2W Nozzle (Part No. 419337) = two flow numbers
- 100 in. (254 cm) perimeter maximum
- 32 in. (81.3 cm) diameter maximum

The chart below shows the maximum protection available from each duct nozzle.

Description	Part No.	3.0 Gallon System	1.5 Gallon System
2W Nozzle	419337	Maximum 100 in. (254 cm) Perimeter	Maximum 100 in. (254 cm) Perimeter
1W Nozzle	419336	Maximum 50 in. (127 cm) Perimeter	Maximum 50 in. (127 cm) Perimeter

ALL PENETRATIONS TO THE HOOD SHALL BE SEALED WITH AN APPROVED QUICK SEAL DEVICE

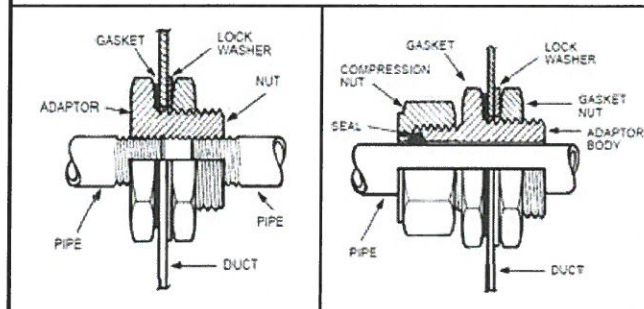

Johnson Controls Fire Protection
540 Civic Blvd #105
Raleigh, NC 27610

BISCUITVILLE
1608 NC HWY 24/87
CAMERON NC 28326

SIZE	DWG #	DWG	REV
		KITCHEN FIRE SYSTEM	1
SCALE	N/A	SHEET	3 OF 5

Griddle Protection 260 (2-Flow) Nozzle – High Proximity Application

Option 2 – Nozzle Perimeter Located

30 in. to 50 in. (762 mm to 1270 mm) above the cooking surface.

This high proximity application uses the 260 nozzle.

- ▶ The nozzle is stamped with 260 indicating this is a two-flow nozzle and must be counted as two flow numbers.

One 260 nozzle will protect a maximum cooking area of 1440 in.² (92903 mm²) with a maximum dimension of 48 in. (1219 mm).

When using this nozzle for griddle protection, the nozzle must be positioned along the cooking surface perimeter to 2 in. (50 mm) inside perimeter, and aimed at the center of the cooking surface. See Figure 4-43 and 4-44.

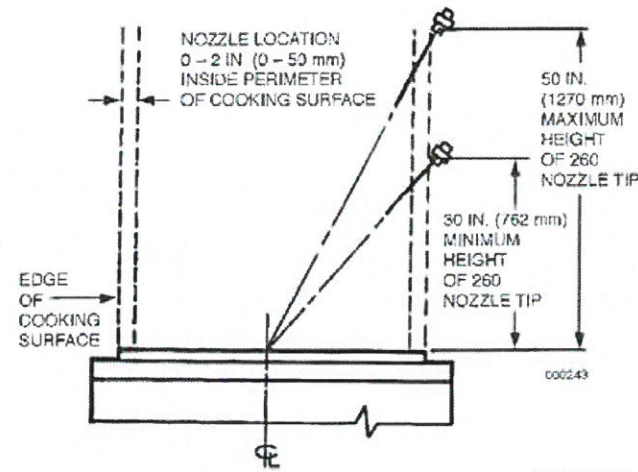
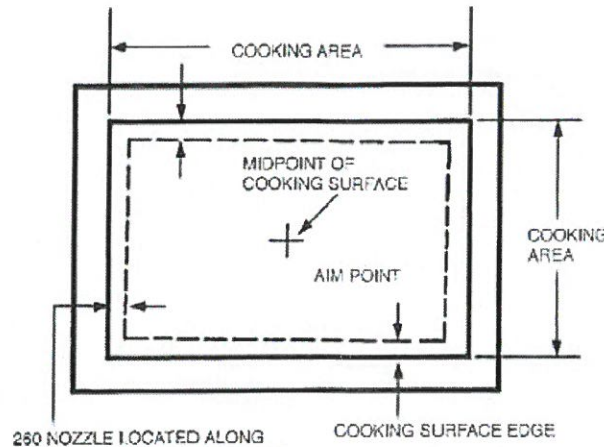



FIGURE 4-43
000243



260 NOZZLE LOCATED ALONG ANY SIDE OF GRIDDLE SURFACE WITHIN 0 - 2 IN. (0 - 51 mm) OF COOKING SURFACE EDGE. NOZZLE MUST BE AIMED AT MIDPOINT OF COOKING SURFACE.

FIGURE 4-44
000241

	Johnson Controls Fire Protection 540 Civic Blvd #105 Raleigh, NC 27610		
	BISCUITVILLE 1608 NC HWY 24/87 CAMERON NC 28326		
SIZE	DWG #	DWG	REV
		KITCHEN FIRE SYSTEM	1
SCALE	N/A	SHEET	4 OF 5

FRYER PROTECTION

Fryer – Single Nozzle Protection

1. Design requirements for fryers are broken down into two types.

A. FRYERS WITHOUT DRIPBOARDS

If the fryer does not include a dripboard, measure the internal depth (horizontal dimension from front to back) and length of the frypot.

B. FRYERS WITH DRIPBOARDS

If the fryer includes any dripboard areas, measure both the internal depth (horizontal dimension from front to back) and length of the frypot portion, and then measure the internal depth and length of the overall hazard area including any dripboard areas.

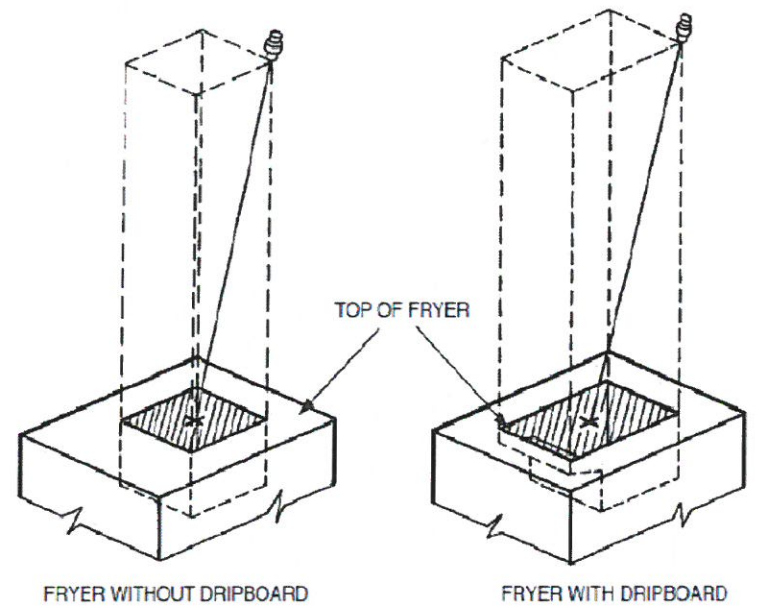

NOZZLE TIP POSITIONED ANYWHERE ALONG OR WITHIN PERIMETER OF COOKING SURFACE AND AIMED TO THE CENTER OF THE COOKING AREA.

Max. Size Frypot Only	Max. Size Overall With Dripboard	Type of Nozzle	Nozzle Height Above Top of Fryer
18 in. x 18 in. ▶ (457 mm x 457 mm)	18 in. x 27 3/4 in. (457 mm x 704 mm)	3N	25 in. to 35 in. (635 mm to 889 mm)

Range Protection 260 (2-Flow) Nozzle (With or Without Back Shelf/Obstruction)

Single and multiple burner ranges can be protected using a 260 nozzle. The nozzle is stamped with 260 indicating that it is a two-flow nozzle and must be counted as two flow numbers.

When using the 260 nozzle for range protection with or without back shelf or other similarly sized obstruction, the maximum length of burner grates being protected must not exceed 32 in. (812 mm) and the maximum area of the burner grates must not exceed 384 in.² (24774 mm²). Nozzle must be located on the front edge of the burner grates and aimed at a point 10 in. (254 mm) from the back edge of the burner grates. Nozzle must be mounted 30 to 40 in. (762 to 1016 mm) above the hazard surface. See Figure 4-38.

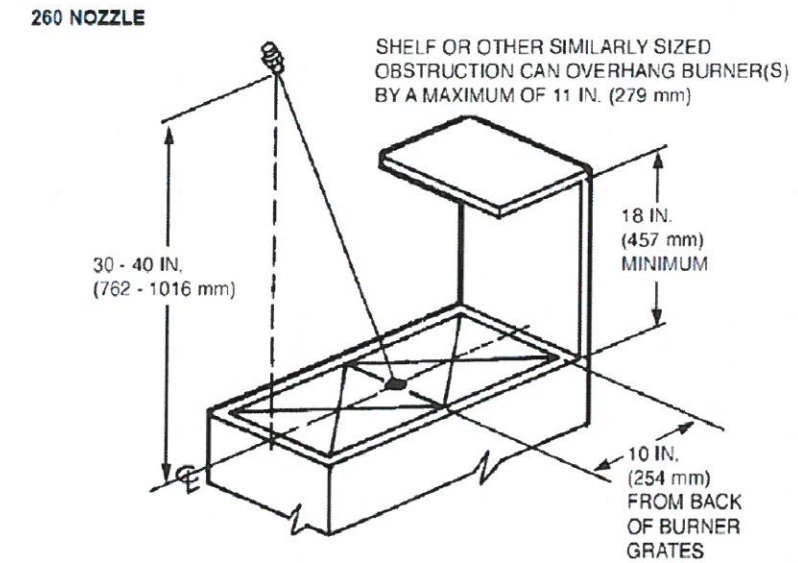

FIGURE 4-38

000238a



Johnson Controls Fire Protection
540 Civic Blvd #105
Raleigh, NC 27610

BISCUITVILLE
1608 NC HWY 24/87
CAMERON NC 28326

SIZE	DWG #	DWG	REV
		KITCHEN FIRE SYSTEM	1
SCALE	N/A	SHEET	5 OF 5