

ES-50X

Intelligent Addressable FACP with Communicator



Addressable Fire Alarm Control Panels

General

The ES-50X is the latest intelligent addressable fire alarm control panel (FACP) from Fire-Lite Alarms and is a direct replacement for the MS-9050UD/LS. The ES-50X comes with a pre-installed communicator and supports up to 50 addressable devices in any combination of detectors or modules. With an extensive list of powerful features, the ES-50X programs just like Fire-Lite's other addressable panels, yet fits into applications previously served only by conventional panels.

The pre-installed IPOTS-COM is a dual technology (POTS and IP) communicator. The POTS transmits system status (alarms, troubles, AC loss, etc.) to a Central Station via the public switched telephone network. The IP communicator's internet monitoring capability sends alarm signals over the Internet saving the monthly cost of two dedicated business telephone lines. Although not required, the secondary telephone line may be retained providing backup communication over the public switched telephone line. Optional cellular reporting is available using the CELL-MOD or CELL-CAB-FL.

Remote and local programming of the control panel is possible using the FS-Tools Upload/Download utility. Programming databases can be uploaded/downloaded via the panel's USB port (and USB cable) or via an ethernet connection using the IPOTS-COM communicator. The USB port also allows for the download or upload of the entire program, history file, walk-test data, current status and system voltages by means of a USB flash drive.

The power supply and all electronics are contained on a circuit board supported on a new quick install chassis and housed in a metal cabinet. Available accessories include local and remote upload/download software, remote annunciators, and reverse polarity/city box transmitter (4XTMF).

Features

- Listed to UL Standard 864, 10th edition
- Pre-installed IPOTS-COM Ethernet IP and POTS (Plain Old Telephone Service) Central Station Communicator
- Optional CELL-MOD or CELL-CAB-FL GSM Central Station Communicator over AlarmNet®
- Compatible with SWIFT® wireless devices
- Auto-programming (learn mode) reduces installation time. Reports two devices set to the same address
- Two independently programmable, built-in Style Z (Class A) or Style Y (Class B) NAC circuits
- Selectable strobe synchronization for System Sensor, Wheelock, and Gentex devices
- Notification Appliance Circuit End of Line resistor matching
- Four programmable function keys for ease of maintenance
- Two programmable relays and one fixed trouble relay
- Built-in Programmer
- Integral 80-character LCD display with backlighting
- Real-time clock/calendar with automatic daylight savings control
- History file with 1,000 event capacity
- Addressable sounder base
- Multi-criteria detector (smoke, heat, CO) with programmable response
- Control module delay timer
- Automatic detector sensitivity testing (NFPA 72 compliant)
- Automatic device type-code verification
- Point trouble identification
- Waterflow selection per module point
- Alarm verification selection per detector point

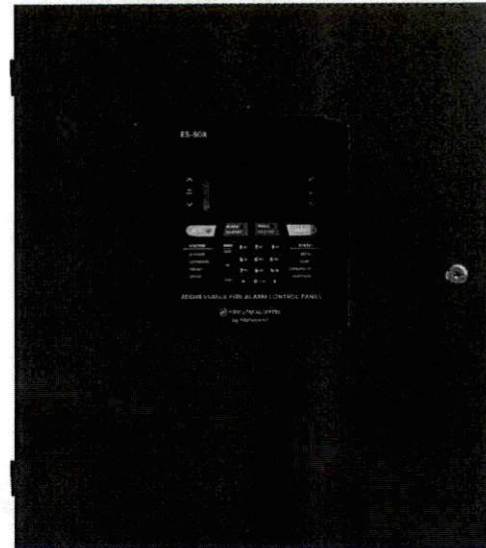

- Maintenance alert warns when smoke detector dust accumulation is excessive
- One-person audible or silent walktest with walktest log & printout
- System alarm verification selection per detector point
- PAS (Positive Alarm Sequence) and Pre-signal per point (NFPA 72 compliant)
- Up to 16 ANN-BUS annunciators- 8 per each ANN-Bus
- Remote Acknowledge, Alarm Silence, Reset and Drill via addressable modules or remote annunciator
- Upload/Download of program and data via USB with optional FS-Tools Programming Utility

SLC COMMUNICATION LOOP

- Supports LiteSpeed™ and CLIP protocols
- SLC operates up to 10,000 ft. (3,000 m) in LiteSpeed mode with twisted, unshielded wire
- Single addressable SLC loop which meets NFPA Class B and Class A requirements
- 50 addressable device capacity (any combination of addressable detectors and modules)
- Compatible with Fire-Lite's addressable devices (refer to the *SLC Wiring Manual*)

NOTIFICATION APPLIANCE CIRCUITS (NACS)

- Two independently programmable output circuits. Circuits can be configured for the following outputs:
 - Style Y (Class B)
 - Style Z (Class A)
 - Silence Inhibit and Autosilence timer options
 - Continuous, March Time, Temporal, or California code for main circuit board NACs with two-stage capability
 - Selectable strobe synchronization per NAC
 - 2.5 A special application, 250mA regulated, total power for NACs
- NOTE:** Maximum or total 24VDC system power shared between all NAC circuits and the ANN-BUS is 2.7 A

PROGRAMMING AND SOFTWARE

- Autoprogramming (learn mode) reduces installation time

- Custom English labels (per point) may be manually entered or selected from an internal library file
- Two programmable Form-C relay outputs
- 50 software zones
- Continuous fire protection during online programming
- Program Check automatically catches common errors not linked to any zone or input point
- **OFFLINE PROGRAMMING:** Create the entire program in your office using FS-Tools, a Windows®-based software package, and upload/download system programming locally. Offline programming requires an ethernet connection. FS-Tools is available on www.firelite.com.

User interface

LED INDICATORS

- Fire Alarm (red)
- CO Alarm (red)
- AC Power (green)
- Supervisory (yellow)
- Trouble (yellow)
- Ground fault (yellow)
- Battery fault (yellow)
- Disabled (yellow)
- Maintenance (yellow)
- Communication (yellow)
- Alarm Silenced (yellow)
- F1-F4 Programmable Function Keys (yellow)

KEYPAD

- 16 key alpha-numeric pad
- Acknowledge
- Alarm Silence
- Drill (Manual Evacuate)
- Four (4) programmable function keys
- Reset (lamp test)

Product Line Information

ES-50X: Addressable Fire Alarm Control Panel with one SLC loop. Includes main circuit board with display, pre-installed IPOTS-COM communicator, chassis with transformer, backbox with door, plastic bag containing screws, cables, key, etc. (For ES-50XC, refer to DF-60954.)

FS-Tools: Programming software for Windows®-based PC computer. Available for download at www.firelite.com.

CELL-CAB-FL/CELL-MOD: Optional GSM communicators.

IPOTS-COM: Dual technology (POTS and IP) communicator. (replacement board)

DP-ES-R: Optional dress panel for the ES-50X.

TR-CE: Optional trim ring for semi-flush mounting.

BB-2F: Optional cabinet for one or two modules.

BB-6F: Optional cabinet for up to six modules mounted on CHS-6 chassis.

BB-26: Battery backbox, holds up to two 25 AH batteries & CHG-75.

BB-55F: Battery box, houses two 55 AH batteries

CHS-6: Chassis, mounts up to six multi-modules in a BB-6F cabinet.

CHG-75: Battery charger for lead-acid batteries with a rating of 25 to 75 AH.

CHG-120F: Remote battery charging system for lead-acid batteries with a rating of 55 to 120 AH. Requires additional BB-55F for mounting.

BAT Series: Batteries, see data sheet DF-52397.

PRN Series: UL listed compatible event printer. Uses tractor-fed paper.

OPTIONAL MODULES

4XTMF Reverse Polarity Transmitter Module: Provides a supervised output for local energy municipal box transmitter, alarm and trouble. Includes a disable switch and disable trouble LED.

COMPATIBLE ANNUNCIATORS

ANN-80: Remote, red LCD annunciator mimics the information displayed on the FACP LCD display. Recommended wire type is unshielded.

ANN-100: Remote LCD annunciator mimics the information displayed on the FACP LCD display. Recommended wire type is unshielded. For use in FM applications only.

ANN-I/O: LED Driver Module provides connections to a user supplied graphic annunciator. (See DF-52430.)

ANN-LED: Annunciator Module provides three LEDs for each zone: Alarm, Trouble, and Supervisory. Ships with red enclosure. (See DF-60241.)

ANN-RLED: Provides alarm (red) indicators for up to 30 input zones or addressable points. (See DF-60241.)

ANN-RLY: Relay Module provides 10 programmable Form-C relays. Can be mounted inside the cabinet. (See DF-52431.)

ANN-S/PG: Serial/Parallel Printer Gateway module provides a connection for a serial or parallel printer. (See DF-52429.)

ADDRESSABLE DEVICES

All feature a polling LED and rotary switches for addressing.

SD365: Addressable low-profile photoelectric smoke detector. LiteSpeed only.

SD365-IV: Addressable low-profile photoelectric smoke detector. Ivory. LiteSpeed and CLIP mode.

SD365T: Addressable low-profile photoelectric smoke detector with thermal sensor. LiteSpeed only.

SD365T-IV: Addressable low-profile photoelectric smoke detector with thermal sensor. Ivory. LiteSpeed and CLIP mode.

SD365R: Remote test capable addressable photoelectric smoke detector for use with DNR(W) duct detector housing. LiteSpeed only.

SD365R-IV: Remote test capable addressable photoelectric smoke detector for use with DNR(W) duct detector housing. Ivory. LiteSpeed and CLIP mode.

H365: Low-profile 135°F fixed thermal sensor. LiteSpeed only.

H365-IV: Low-profile 135°F fixed thermal sensor. Ivory. LiteSpeed and CLIP mode.

H365R: Low-profile, intelligent, rate-of-rise thermal sensor. LiteSpeed only.

H365R-IV: Low-profile, intelligent, rate-of-rise thermal sensor. Ivory. LiteSpeed and CLIP mode.

H365HT: Low-profile intelligent 190°F/88°C fixed thermal sensor. LiteSpeed only.

H365HT-IV: Low-profile intelligent 190°F/88°C fixed thermal sensor. Ivory. LiteSpeed and CLIP mode.

Legacy Devices

SD355: Addressable low-profile photoelectric smoke detector.

SD355T: Addressable low-profile photoelectric smoke detector with thermal sensor.

SD355R: Remote test capable addressable photoelectric smoke detector for use with DNR(W) duct detector housing.

SD355CO: Addressable, low-profile device that provides fire, heat, and carbon monoxide (CO) detection.

H355: Fast-response, low-profile heat detector.

H355R: Fast-response, low-profile heat detector with rate-of-rise option.

H355HT: Fast-response, low-profile heat detector that activates at 190°F/88°C.

AD355: Low-profile, intelligent, "Adapt" multi-sensor detector (B350LP base included).

B200S: Programmable, addressable sounder base

B200SR: Addressable sounder base.

BEAM355: Intelligent beam smoke detector.

BEAM355S: Intelligent beam smoke detector with integral sensitivity test.

D355PL: InnovairFlex low-flow non-relay duct-detector housing; includes SD355R.

DNR: InnovairFlex low-flow non-relay duct-detector housing. (Order SD355R/SD365R separately.)

DNRW: InnovairFlex low-flow non-relay duct-detector housing, with NEMA-4 rating. Watertight. (Order SD355R/SD365R separately.)

Addressable Modules

MMF-300: Addressable Monitor Module for one zone of normally-open dry-contact initiating devices. Mounts in standard 4.0" (10.16 cm.) box. Includes plastic cover plate and end-of-line resistor. Module may be configured for either a Style B (Class B) or Style D (Class A) IDC.

MDF-300: Dual Monitor Module. Same as MMF-300 except it provides two Style B (Class B) only IDCs.

MMF-301: Miniature version of MMF-300. Excludes LED and Style D option. Connects with wire pigtailed. May mount in device backbox.

MMF-302: Similar to MMF-300. Addressable Monitor Module for one zone of conventional two-wire detectors. Requires resettable 24 VDC power. Refer to the *Device Compatibility Document* for listed compatible devices and quantity limitation.

CMF-300: Addressable Control Module for one Style Y/Z (Class B/A) zone of supervised polarized Notification Appliances. Mounts directly to a 4.0" (10.16 cm.) electrical box. NAC option requires external 24 VDC to power notification appliances.

CRF-300: Addressable relay module containing two isolated sets of Form-C contacts, which operate as a DPDT switch. Mounts directly to a 4.0" (10.16 cm.) box, surface mount using the SMB500.

BG-12LX: Addressable manual pull station with interface module mounted inside.

I300: This module isolates the SLC loop from short circuit conditions (required for Style 6 or 7 operation).

ISO-6: Six-fault isolator module. Mount one or two modules in a BB-2F cabinet (optional). Mount up to six modules on a CHS-6 chassis in a BB-6F cabinet.

SMB500: Used to mount all modules except MMF-301 and M301.

MMF-300-10: Ten-input monitor module. Mount one or two modules in a BB-2F cabinet (optional). Mount up to six modules on a CHS-6 chassis in a BB-6F cabinet.

MMF-302-6: Six-zone interface module. Mount one or two modules in a BB-2F cabinet (optional). Mount up to six modules on a CHS-6 chassis in a BB-6F cabinet.

CMF-300-6: Six-circuit supervised control module. Mount one or two modules in a BB-2F cabinet (optional). Mount up to six modules on a CHS-6 chassis in a BB-6F cabinet.

CRF-300-6: Six-relay control module (Form-C relays). Mount one or two modules in a BB-2F cabinet (optional). Mount up to six modules on a CHS-6 chassis in a BB-6F cabinet.

SWIFT Wireless Devices

W-GATE: LiteSpeed Wireless Gateway

W-SD355: LiteSpeed intelligent, wireless photo detector.

W-H355R: LiteSpeed intelligent wireless rate of rise (135°) heat detector.

W-SD355T: intelligent wireless photo/heat detector.

W-H355: LiteSpeed intelligent wireless fixed-temperature (135°) heat detector.

W-MMF: LiteSpeed Intelligent wireless monitor module.

W-CRF: LiteSpeed Intelligent wireless relay module.

W-BG12LX: LiteSpeed Intelligent wireless pull station.

WAV-RL, WAV-WL, WAV-CRL, WAV-CWL: LiteSpeed Intelligent AV bases.

W-USB: Wireless USB radio/antenna dongle that plugs into the USB port of a PC running SWIFT Tools.

SWIFT Tools: Programming and diagnostic utility for the Wireless Gateway and devices. Available for download from firelite.com.

NOTE: For more information on *Compatible Addressable Devices* for use with the ES-50X, see the following data sheets (document numbers): SD365 Series (DF-61010), H365 Series (DF-61011), AD355 (DF-52386), BG-12LX (DF-52013), CMF-300-6 (DF-52365), CRF-300-6 (DF-52374), CMF/CRF Series (DF-52130), CP355 (DF-52383), H355 Series (DF-52385), I300 (DF-52389), ISO-6 (DF-60485), MMF-300 Series/MDF-300 (DF-52121), MMF-300-10 (DF-52347), MMF-302-6 (DF-52356), SD355/SD355T (DF-52384), and SLC Wiring Manual (51309).

NOTE: Legacy 300 Series detection devices such as the CP300/CP350, SD300(T)/SD350(T) and older modules such as the M300, M301, M302, C304, and BG-10LX are not compatible with LiteSpeed polling. If the SLC contains one of these devices, polling must be set for standard CLIP protocol. Please consult factory for further information on previous 300 Series devices.

ADDRESSABLE DEVICE ACCESSORIES

End-of-Line Resistor Assembly (R-47K and R-3.9K): The 47k ohm assembly supervises the MMF-300, MDF-300, MMF-301, and CMF-300 module circuits. The 3.9k ohm assembly supervises the MMF-302 module circuit. These resistors are included with each module.

Power Supervision Relay: Supervises the power to 4-wire smoke detectors and notification appliances.

Wiring Requirements

While shielded wire is not required, it is recommended that all SLC wiring be twisted-pair to minimize the effects of electrical interference. Refer to the panel manual for wiring details.

SYSTEM SPECIFICATIONS

System Capacity

- Intelligent Signaling Line Circuits..... 1
- Addressable device capacity..... 50
- Programmable software zones..... 50
- Annunciators..... 16

Electrical Specifications

AC Power: Operates in either 120 or 240 VAC, 50/60 Hz, 3.25 A, auto-sensing- no switch required. Wire size: minimum 14 AWG (2.00 mm²) with 600 V insulation. Nonpower-limited, supervised.

Battery: Two 12 V 18 AH lead-acid batteries. Battery Charger Capacity: 7-18 AH (ES-50X cabinet holds maximum of two 18 AH batteries.)

Communication Loop: Supervised and power-limited.

Notification Appliance Circuits: Terminal Block provides connections for two NACs, Style Y (Class B) or Style Z (Class A). Special Application power. Power-limited, supervised circuitry. Maximum signaling current per circuit: 2.5 amps special application, 250mA regulated. End-of-Line Resistor: 4.7k ohm, ½ watt (P/N 71252 UL listed) for Style Y (Class B) NAC; system capable of 1.9 kΩ - 22 kΩ ELR range. Refer to the *Fire•Lite Device Compatibility Document* for listed compatible devices.

Two Programmable Relays and One Fixed Trouble Relay: Contact rating: 2.0 A @ 30 VDC (resistive), 0.5 A @ 30 VAC (resistive). Form-C relays, non-power-limited, non-supervised.

Cabinet Specifications

Door: 19.26" (48.92 cm.) high x 16.82" (42.73 cm.) wide x 0.72" (1.82 cm.) deep. **Backbox:** 19.00" (48.26 cm.) high x 16.65" (42.29 cm.) wide x 5.25" (13.34 cm.) deep. **Trim Ring (TR-CE):** 22.00" (55.88 cm.) high x 19.65" (49.91 cm.) wide.

Shipping Specifications

Weight: 26.9 lbs. (12.20 kg.) **Dimensions:** 20.00" (50.80 cm.) high x 22.5" (57.15 cm.) wide x 8.5" (21.59 cm.) deep.

Temperature and Humidity Ranges

This system meets NFPA requirements for operation at 0 – 49°C/32 – 120°F and at a relative humidity 93% ± 2% RH (noncondensing) at 32°C ± 2°C (90°F ± 3°F). However, the useful life of the system's standby batteries and the electronic components may be adversely affected by extreme temperature ranges and humidity. Therefore, it is recommended that this system and its peripherals be installed in an environment with a normal room temperature of 15 – 27°C/60 – 80°F.

NFPA Standards

The ES-50X complies with the following NFPA 72 Fire Alarm Systems requirements:

- **LOCAL** (Automatic, Manual, Waterflow and Sprinkler Supervisory).
- **AUXILIARY** (Automatic, Manual and Waterflow) (requires 4XTMF).
- **REMOTE STATION** (Automatic, Manual and Waterflow) (Where a DACT is not accepted, the alarm, trouble and supervisory relays may be connected to UL 864 listed transmitters. For reverse polarity signaling of alarm and trouble, 4XTMF is required.)
- **PROPRIETARY** (Automatic, Manual and Waterflow).
- **CENTRAL STATION** (Automatic, Manual and Waterflow, and Sprinkler Supervised).
- **OT, PSDN** (Other Technologies, Packet-switched Data Network)
- **IBC 2012, IBC 2009, IBC 2006, IBC 2003, IBC 2000** (Seismic).
- **CBC 2007** (Seismic)

Agency Listings and Approvals

The listings and approvals below apply to the basic ES-50X control panel. In some cases, certain modules may not be listed by certain approval agencies, or listing may be in process. Consult factory for latest listing status.

- **UL:** S624
- **FM approved**
- **CSFM:** 7165-0075:0500
- **FDNY:** COA #6261

NOTE: See DF-60954 for ULC-listed model.

AlarmNet®, Fire-Lite® Alarms, SWIFT®, and System Sensor® are registered trademarks of Honeywell International Inc. Microsoft® and Windows® are registered trademarks of the Microsoft Corporation. ©2018 by Honeywell International Inc. All rights reserved. Unauthorized use of this document is strictly prohibited.



This document is not intended to be used for installation purposes.
We try to keep our product information up-to-date and accurate.
We cannot cover all specific applications or anticipate all requirements.
All specifications are subject to change without notice.

For more information, contact Fire•Lite Alarms. Phone: (800) 627-3473, FAX: (877) 699-4105.
www.firelite.com



Country of Origin: USA

CELL-CAB-FL(C) and CELL-MOD(C)

Cellular Fire Alarm Communicators



Communicators

General

The CELL-CAB-FL(C) and CELL-MOD(C) are cellular communicator options for Fire-Lite Endurance Series addressable fire alarm control panels (FACPs).

These GSM communicators provide cellular communication as an alternate method of central station reporting. Combined with the FACP's onboard communicator, they provide dual path cellular and IP reporting capability, while eliminating the need and cost of separate dialer capture modules and special programming. Battery backup from the control panel maximizes overall system efficiency.

Small in size, easy to install, with a programmable supervision time of 1-60 minutes, these communicator models can be positioned remotely from the fire alarm control panel via 4-wire serial bus for optimum reception. The CELL-CAB-FL(C) and CELL-MOD(C) are UL 864 and NFPA 72 fire code compliant for sole, primary, or backup communications. They work with AlarmNet® to provide a UL-listed connection to the central station.

The CELL-CAB-FL(C) includes a GSM communicator within a metal cabinet enclosure with lock and key and includes an external antenna. The CELL-MOD(C) houses the GSM communicator in a plastic enclosure and has an option for an external antenna.

Compatibility

The CELL-CAB-FL(C) and CELL-MOD(C) are compatible with the following Endurance Series FACPs:

- ES-50X(C): 50 point addressable FACP
- ES-200X(C): 198 point addressable FACP

Features

- Communicate directly with Endurance Series panels
- Easy installation - no need for special programming or separate dialer module
- Battery backup provided by the panel to increase system efficiency and decrease cost
- Provide dual-path cellular and IP reporting capability
- UL 864 and NFPA 72 code compliant for sole, primary, and backup communications
- Easily managed accounts through on-line management tools
- Remote mounting up to 6,000 feet (1,828.8m)
- Quality of Service (QOS) diagnostics via AlarmNet convey vital communicator information such as when messages are received, signal strength, and message path used
- Programmable supervision time from 1-60 minutes
- Provide full data reporting using Contact ID format

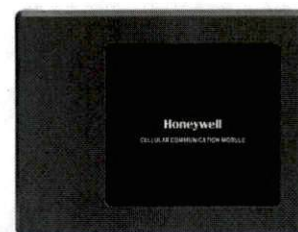

CELL-MOD(C)



CELL-CAB-FL(C)

SYSTEM SPECIFICATIONS

PHYSICAL

CELL-CAB-FL(C): 10.38"W x 10.165"H x 3.176"D
(26.37cm x 25.82 cm x 8.07cm)

CELL-MOD(C): 7.809"W x 5.982"H x 1.5"D
(19.83cm x 15.19cm x 3.81cm)

Shipping Weight:

- CELL-MOD: 1.3 lbs (589.7 g)
- CELL-CAB-FL: 5.2 lbs (2.36 Kg)

Color: Red

ENVIRONMENTAL

Operating Temperature: 32°F to 120°F (0°C to 49°C)

Humidity: 10 to 93% relative humidity (non-condensing)

ELECTRICAL

Standby Current: 55mA

Alarm Current: 100mA

RADIO TRANSCEIVER

- 3G Cellular Radio
- UMTS WCDMA FDD 850/1900MHz
- FCC part 15, 22, 24, and 68 compliant

COMMUNICATION PROTOCOLS

- HSPA+ (4G) and HSPA (HSDPA & HSUPA) (3G)

ORDERING INFORMATION

CELL-CAB-FL: Cellular module housed in a metal cabinet with lock and key. Includes external antenna

CELL-CAB-FLC: Cellular module housed in a metal cabinet with lock and key. Includes external antenna. For use in Canadian applications with Canadian model FACPs.

CELL-MOD: Cellular module housed in a plastic enclosure. (External antenna sold separately)

CELL-MODC: Cellular module housed in a plastic enclosure. (External antenna sold separately) For use in Canadian applications with Canadian model FACPs.

CELL-ANTENNA: 3dB gain external/remote antenna

7626-50HC: 50 ft. (15.24 m) antenna cable, low loss

ES-50X: 50 point addressable FACP with pre-installed IPOTS-COM communicator

ES-50XC: 50 point addressable FACP with pre-installed IPOTS-COM communicator, for use in Canadian applications

ES-200X: 198 point addressable FACP with pre-installed IPOTS-COM communicator

ES-200XC: 198 point addressable FACP with pre-installed IPOTS-COM communicator, for use in Canadian applications

IPOTS-COM: Dual technology (POTS and IP) communicator (replacement board) for the Endurance Series panels

APPROVALS

- **UL:** S3511 (CELL-MOD), S2424 (CELL-CAB-FL)
- **ULC:** S3511 (CELL-MODC), S2424 (CELL-CAB-FLC)
- **CSFM:** 7300-0075:0504
- **FCC ID:** CFS8DLPHS8-US

AlarmNet® and Fire-Lite® Alarms are registered trademarks of Honeywell International Inc.

©2018 by Honeywell International Inc. All rights reserved. Unauthorized use of this document is strictly prohibited.



This document is not intended to be used for installation purposes.
We try to keep our product information up-to-date and accurate.
We cannot cover all specific applications or anticipate all requirements.
All specifications are subject to change without notice.

For more information, contact Fire-Lite Alarms. Phone: (800) 627-3473, FAX: (877) 699-4105.
www.firelite.com



Country of Origin: USA

ANN-80

80-Character LCD Serial Annunciator

 **FIRE·LITE ALARMS**
by Honeywell

Annunciators

General

The ANN-80 annunciator is a compact, backlit, 80-character LCD fire annunciator that mimics the Fire Alarm Control Panel (FACP) display. It provides system status indicators for AC Power, Alarm, Trouble, Supervisory, and Alarm Silenced conditions. The ANN-80 and the FACP communicate over a two-wire serial interface employing the ANN-BUS communication format. Connected devices are powered, via two additional wires, by either the host FACP or a remote UL-listed, filtered power supply. ANN-80 is red; for white, order ANN-80-W.

The ANN-80 displays English-language text of system point information including device type, zone, independent point alarm, trouble or supervisory status, as well as any custom alpha labels programmed into the control panel. It includes control switches for remote control of critical system functions. (A keyswitch prevents unauthorized operation of the control switches.)

Up to eight ANN-80s may be connected to the ANN-BUS of each FACP. No programming is required, which saves time during system commissioning.

Features

- Listed to UL Standard 864, 9th Edition.
- Backlit 80-character LCD display (20 characters x 4 lines).
- Mimics all display information from the host panel.
- Control switches for System Acknowledge, Signal Silence, Drill, and Reset.
- Control switches can be independently enabled or disabled at the FACP.
- Keyswitch enables/disables control switches and mechanically locks annunciator enclosure
- Keyswitch can be enabled or disabled at the FACP.
- Enclosure supervised for tamper.
- System status LEDs for AC Power, Alarm, Trouble, Supervisory, and Alarm Silence.
- Local sounder can be enabled or disabled at the FACP.
- ANN-80 connects to the ANN-BUS terminal on the FACP and requires minimal panel programming.
- Displays device type identifiers, individual point alarm, trouble, supervisory, zone, and custom alpha labels.
- Time-and date display field.
- Surface mount directly to wall or to single, double, or 4" square electrical box.
- Semi-flush mount to single, double, or 4" square electrical box. Use ANN-SB80KIT for angled view mounting.
- Can be remotely located up to 6,000 feet (1,800 m) from the panel.
- Backlight turns off during AC loss to conserve battery power but will turn back on if an alarm condition occurs.
- May be powered by 24 VDC from the host FACP or by remote power supply (requires 24 VDC).
- Up to eight ANN-80s can be connected on the ANN-BUS.

Controls and Indicators

- AC Power
- Alarm
- Trouble



- Supervisory
- Alarm Silenced

Specifications

- **Operating voltage range:** 18 VDC to 28 VDC.
- **Current consumption @ 24 VDC nominal** (filtered and non-resettable): 40 mA maximum.
- **Ambient temperature:** 32°F to 120°F (0°C to 49°C).
- **Relative humidity:** 93% ± 2% RH (noncondensing) at 32°C ± 2°C (90°F ± 3°F).
- 5.375" (13.65 cm.) high x 6.875" (17.46 cm.) wide x 1.375" (3.49 cm.) deep.
- For use indoors in a dry location.
- All connections are power-limited and supervised.

Agency Listings and Approvals

The listings and approvals below apply to the ANN-80. In some cases, certain modules may not be listed by certain approval agencies, or listing may be in process. Consult factory for latest listing status.

- **UL:** S2424
- **FM approved**
- **CSFM:** 7120-0075:211
- **MEA:** 442-06-E

The ANN-BUS

POWERING THE DEVICES ON THE ANN-BUS FROM AUXILIARY POWER SUPPLY

The ANN-BUS can be powered by an auxiliary power supply when the maximum number of ANN-BUS devices exceeds the ANN-BUS power requirements. See the FACP manual for more information.

ANN-BUS DEVICE ADDRESSING

Each ANN-BUS device requires a unique address (ID Number) in order to communicate with the FACP. A maximum of 8 devices can be connected to the FACP ANN-BUS communication circuit. See the FACP manual for more information.

WIRE REQUIREMENTS: COMMUNICATIONS CIRCUIT

The ANN-80 connects to the FACP ANN-BUS communications circuit. To determine the type of wire and the maximum wiring distance that can be used with FACP ANN-BUS accessory modules, it is necessary to calculate the total worst case current draw for all modules on a single 4-conductor bus. The total worst case current draw is calculated by adding the individual worst case currents for each module.

NOTE: For total worst case current draw on a single ANN-BUS refer to appropriate FACP manual.

After calculating the total worst case current draw, the following table specifies the maximum distance the modules can be located from the FACP on a single wire run. The table ensures 6.0 volts of line drop maximum. In general, the wire length is limited by resistance, but for heavier wire gauges, capacitance is the limiting factor.

These cases are marked in the chart with an asterisk (*). Maximum length can never be more than 6,000 feet (1,800 m), regardless of gauge used. See table below.

WIRE REQUIREMENTS: POWER CIRCUIT

- 14 to 18 AWG (0.75 - 2.08 mm²) wire for 24 VDC power circuit is acceptable. Power wire distance limitation is set by 1.2 volt maximum line drop from source to end of circuit.
- All connections are power-limited and supervised.
- A maximum of eight ANN-80 modules may be connected to this circuit.

Communication Pair Wiring Distance: FACP to Last ANN-BUS Module				
Total Worst Case Current Draw (amps)	22 Gauge	18 Gauge	16 Gauge	14 Gauge
0.100	1,852 ft.	4,688 ft.	* 6,000 ft.	*6,000 ft.
0.200	926 ft.	2,344 ft.	3,731 ft.	5,906 ft.
0.300	617 ft.	1,563 ft.	2,488 ft.	3,937 ft.
0.400	463 ft.	1,172 ft.	1,866 ft.	2,953 ft.
0.500	370 ft.	938 ft.	1,493 ft.	2,362 ft.
0.600	309 ft.	781 ft.	1,244 ft.	1,969 ft.
0.700	265 ft.	670 ft.	1,066 ft.	1,687 ft.
0.800	231 ft.	586 ft.	933 ft.	1,476 ft.
0.900	206 ft.	521 ft.	829 ft.	1,312 ft.
1.000 (max.)	185 ft.	469 ft.	746 ft.	1,181 ft.

WIRING CONFIGURATION

The following figure illustrates the wiring between the FACP and ANN-BUS devices.

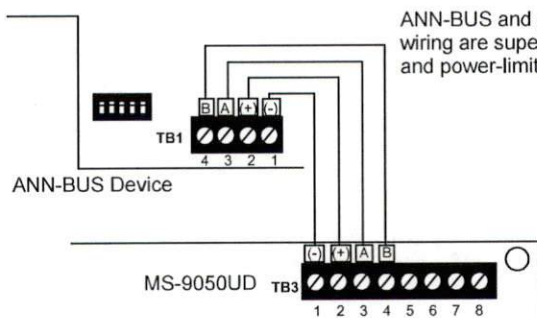

FACP Wiring to ANN-BUS Device

ORDERING OPTIONS:

ANN-80: Red 80 character LCD Annunciator.

ANN-80-W: White, 80 character LCD Annunciator.

ANN-SB80KIT-R: Red surface mount backbox with angled wedge.

ANN-SB80KIT-W: White surface mount backbox with angled wedge.

FireLite® Alarms is a registered trademark of Honeywell International Inc. ©2009 by Honeywell International Inc. All rights reserved. Unauthorized use of this document is strictly prohibited.



This document is not intended to be used for installation purposes. We try to keep our product information up-to-date and accurate. We cannot cover all specific applications or anticipate all requirements. All specifications are subject to change without notice.



For more information, contact Fire•Lite Alarms. Phone: (800) 627-3473, FAX: (877) 699-4105. www.firelite.com

BG-12LX

Addressable Manual Pull Station



Addressable Devices

General

The Fire-Lite BG-12LX is a state-of-the-art, dual-action (i.e., requires two motions to activate the station) pull station that includes an addressable interface (mounted inside) for Fire-Lite's addressable fire alarm control panels (FACPs). Because the BG-12LX is addressable, the control panel can display the exact location of the activated manual station. This leads fire personnel quickly to the location of the alarm.

Features

- Maintenance personnel can open station for inspection and address setting without causing an alarm condition.
- Built-in bicolor LED, which is visible through the handle of the station, flashes in normal operation and latches steady red when in alarm.
- Handle latches in down position and the word "ACTIVATED" appears to clearly indicate the station has been operated.
- Captive screw terminals wire-ready for easy connection to SLC loop (accepts up to 12 AWG/3.25 mm² wire).
- Can be surface mounted (with SB-10 or SB-I/O) or semi-flush mounted. Semi-flush mount to a standard single-gang, double-gang, or 4" (10.16 cm) square electrical box.
- Smooth dual-action design.
- Meets ADAAG controls and operating mechanisms guidelines (Section 4.1.3[13]); meets ADA requirement for 5 lb. maximum activation force.
- Highly visible.
- Attractive shape and textured finish.
- Key reset.
- Includes Braille text on station handle.
- Optional trim ring (BG12TR).
- Meets UL 38, Standard for Manually Actuated Signaling Boxes.

Construction

Shell, door, and handle are molded of durable polycarbonate material with a textured finish.

Specifications

- **Shipping Weight:** 9.6 oz. (272.15 g)
- **Normal operating voltage:** 24 VDC.
- **Maximum SLC loop voltage:** 28.0 VDC.
- **Maximum SLC standby current:** 375 μ A.
- **Maximum SLC alarm current:** 5 mA.
- **Temperature Range:** 32°F to 120°F (0°C to 49°C)
- **Relative Humidity:** 10% to 93% (noncondensing)
- **For use indoors in a dry location**

Installation

The BG-12LX will mount semi-flush into a single-gang, double-gang, or standard 4" (10.16 cm) square electrical outlet box, or will surface mount to the model SB-10 or SB-I/O surface backbox. If the BG-12LX is being semi-flush mounted, then the optional trim ring (BG12TR) may be used. The BG12TR is



FLPullStation.jpg

usually needed for semi-flush mounting with 4" (10.16 cm) or double-gang boxes (not with single-gang boxes).

Operation

Pushing in, then pulling down on the handle causes it to latch in the down/activated position. Once latched, the word "ACTIVATED" (in bright yellow) appears at the top of the handle, while a portion of the handle protrudes from the bottom of the station. To reset the station, simply unlock the station with the key and pull the door open. This action resets the handle; closing the door automatically resets the switch.

Each manual station, on command from the control panel, sends data to the panel representing the state of the manual switch. Two rotary decimal switches allow address settings (1 – 159 with Breakaway Tab removed for MS-9600 Series, 1 – 99 and MS-9200UDLS, 1 – 50 for MS-9050UD).

Architectural/Engineering Specifications

Manual Fire Alarm Stations shall be non-coded, with a key-operated reset lock in order that they may be tested, and so designed that after actual Emergency Operation, they cannot be restored to normal except by use of a key. An operated station shall automatically condition itself so as to be visually detected as activated. Manual stations shall be constructed of red-colored polycarbonate material with clearly visible operating instructions provided on the cover. The word FIRE shall appear on the front of the stations in white letters, 1.00 inches (2.54 cm) or larger. Stations shall be suitable for surface mounting on matching backbox SB-10 or SB-I/O; or semi-flush mounting on a standard single-gang, double-gang, or 4" (10.16 cm) square electrical box, and shall be installed

within the limits defined by the Americans with Disabilities Act (ADA) or per national/local requirements. Manual Stations shall be Underwriters Laboratories listed.

Manual stations shall connect with two wires to one of the control panel SLC loops. The manual station shall, on command from the control panel, send data to the panel representing the state of the manual switch. Manual stations shall provide address setting by use of rotary decimal switches.

Product Line Information

BG-12LX: Dual-action addressable pull station. Includes key locking feature. (Listed for Canadian and non-Canadian applications.)

SB-10: Surface backbox; metal.

SB-I/O: Surface backbox; plastic.

BG12TR: Optional trim ring.

17003: Keys, set of two.

Agency Listings and Approvals

In some cases, certain modules or applications may not be listed by certain approval agencies, or listing may be in process. Consult factory for latest listing status.

- **UL/ULC Listed:** S711 (listed for Canadian and non-Canadian applications).
- **MEA:** 67-02-E.
- **CSFM:** 7150-0075:0184.
- **FM Approved.**

Patented: U.S. Patent No. D428,351; 6,380,846; 6,314,772; 6,632,108.

FireLite® Alarms® is a registered trademark of Honeywell International Inc. ©2012 by Honeywell International Inc. All rights reserved. Unauthorized use of this document is strictly prohibited.



This document is not intended to be used for installation purposes.
We try to keep our product information up-to-date and accurate.
We cannot cover all specific applications or anticipate all requirements.
All specifications are subject to change without notice.



Made in the U.S. A.

For more information, contact Fire•Lite Alarms. Phone: (800) 627-3473, FAX: (877) 699-4105.
www.firelite.com

SD355(A) Series

Addressable Photoelectric Smoke Detectors

Addressable Devices

General

The SD355(A), SD355T(A), and SD355R(A) addressable, low-profile plug-in photoelectric detectors use a state-of-the-art photoelectric sensing chamber with communications to provide open area protection and are used exclusively with Fire-Lite's Addressable Fire Alarm Control Panels (FACPs). The SD355T(A) adds thermal sensors that will alarm at a fixed temperature of 135°F (57°C). Since these detectors are addressable, they will help emergency personnel quickly locate a fire during its early stages, potentially saving precious rescue time while also reducing property damage. Two LEDs on each sensor light to provide a local, visible sensor indication. Remote LED annunciator capability is available as an optional accessory, PN RA100Z(A). The SD355R(A) is a remote test capable detector for use with D355PL(A) or DNR(A)/DNRW duct smoke detector housings.

Features

SLC LOOP

- Two-wire loop connection.
- Unit uses base for wiring.

ADDRESSING

- Addressable by device.
- Rotary, decimal addressing: 01 – 99 with MS-9200UD(LS), and 01 – 159 with MS-9600UD(LS).

ARCHITECTURE

- Unique single-source, dual-chamber design to respond quickly and dependably to a broad range of fires.
- Sleek, low-profile design.
- Integral communications and built-in type identification.
- Built-in tamper-resistant feature.
- Removable cover and insect-resistant screen for simple field cleaning.

OPERATION

- Withstands air velocities up to 4,000 feet-per-minute (20 m/sec.) without triggering a false alarm.
- Factory preset at 1.5% nominal sensitivity for panel alarm threshold level.
- Visible LED "blinks" when the unit is addressed (communicating with the fire panel) and latches on in alarm.

MECHANICALS

- Sealed against back pressure.
- Direct surface mounting or electrical box mounting.
- Mounts to: single-gang box, 3.5" (8.89 cm) or 4.0" (10.16 cm) octagonal box, or 4.0" (10.16 cm) square electrical box (using a plaster ring — included).

OTHER SYSTEM FEATURES

- Fully coated circuit boards and superior RF/transient protection.
- 94-V0 plastic flammability rating.
- Low standby current.



SD355(A) in B210LP(A) Base

2151_2251B_CEILING.png

OPTIONS

- Remote LED output connection, PN RA100Z(A).

Applications

Use photoelectric detectors in life-safety applications to provide a broad range of fire-sensing capability, especially where smoldering fires are anticipated. Ionization detectors are often better than photoelectric detectors at sensing fast, flaming fires.

Construction

These detectors are constructed of off-white fire resistant plastic. SD355(A) series plug-in, low-profile smoke detectors are designed to commercial standards and offer an attractive appearance.

Installation

SD355(A) series plug-in detectors use a detachable mounting base to simplify installation, service and maintenance.

Mount base (all base types) on an electrical backbox which is at least 1.5" (3.81 cm) deep. For a chart of compatible junction boxes, see DF-60059.

NOTE: Because of the inherent supervision provided by the SLC loop, end-of-line resistors are not required. Wiring "T-taps" or branches are permitted for Style 4 (Class B) wiring. SD355R(A) mounts in a D355PL(A) or DNR(A)/DNRW duct detector housing.

Operation

Each SD355(A) series detector uses one of 99 possible addresses on the MS-9200UD(LS) and up to 318 (159 on each loop) on the MS-9600UD(LS) Signaling Line Circuit (SLC). It responds to regular polls from the system and reports its type and status.

The addressable photoelectric sensor in the SD355(A) series has a unique unipolar chamber that responds quickly and uniformly to a broad range of smoke conditions. It can withstand wind gusts up to 4,000 feet-per-minute (20 m/sec.) without sending an alarm level signal. Because of its unipolar chamber, the SD355(A) series is approximately two times more responsive than most photoelectric sensors. This makes it a more stable detector.

Detector Sensitivity Test

Each detector can have its sensitivity tested (required per NFPA 72, Chapter 14 on *Inspection, Testing and Maintenance*) when installed/connected to a MS-9200UD(LS) or MS-9600UD(LS) addressable fire alarm control panel. The results of the sensitivity test can be printed off the MS-9200UD(LS) or MS-9600UD(LS) for record keeping.

Specification

Voltage range: 15 – 32 VDC (peak).

Standby current: 300 μ A @ 24 VDC.

LED current: 6.5 mA @ 24 VDC (latched "ON").

Air velocity: 4,000 ft./min. (20 m/sec.) maximum.

Size: 2.1" (5.33 cm) high; base determines diameter.

- **B210LP(A):** 6.1" (15.5 cm) diameter.
- **B501(A):** 4.1" (10.4 cm) diameter.
- **B200SR(A):** 6.875" (17.46 cm) diameter.
- **B224RB(A):** 6.2" (15.748 cm) diameter.

Weight: 3.6 oz. (102 g).

Operating temperature range: for **SD355(A):** 0°C to 49°C (32°F to 120°F); for **SD355T(A):** 0°C to 38°C (32°F to 100°F). **SD355R(A):** installed in a DNR(A)/DNRW -20°C to 70°C (-4°F to 158°F).

Temperature: 0°C – 49°C (32°F – 120°F).

Relative humidity: 10% – 93%, non-condensing.

Listings

Listings and approvals below apply to the SD355(A), SD355T(A), and SD355RT(A) detectors. In some cases, certain modules may not be listed by certain approval agencies, or listing may be in process. Consult factory for latest listing status.

- **UL Listed:** S1059.
- **ULC Listed:** S1059.
- **CSFM:** 7272-0075:0194.
- **MEA:** 243-02-E.
- **FM approved.**

Product Line Information

NOTE: "A" suffix indicates ULC Listed model.

SD355: Addressable photoelectric detector; B210LP base included.

SD355A: Same as SD355 with ULC Listing; B210LPA base included.

SD355T: Same as SD355 but with **thermal** element; B210LP base included.

SD355TA: Same as SD355T with ULC Listing; B210LPA base included.

SD355R: Remote test capable addressable photoelectric detector for use with a D355PL(A) or DNRA/DNRW duct detector housing; B210LP base included.

SD355RA: Same as SD355R with ULC Listing for use with a D355PLA or DNRA duct detector housing; B210LPA base included.

INTELLIGENT BASES

NOTE: "A" suffix indicates ULC Listed model.

NOTE: The detector's plug-in base can be changed off for special applications. For details about intelligent bases and their mounting, see DF-60059.

B210LP(A): Plug-in detector base (included); standard U.S. flanged low-profile mounting base.

B210LPBP: Bulk pack of B210LP; package contains 10.

B501(A): Standard European flangeless mounting base.

B501BP: Bulk pack of B501; package contains 10.

B200SR(A): Intelligent sounder base capable of producing sound output with ANSI Temporal 3 or continuous tone. Replaces B501BH series bases in retrofit applications.

B224RB(A): Plug-in System Sensor **relay** base. Screw terminals: up to 14 AWG (2.0 mm²). Relay type: Form-C. Rating: 2.0 A @ 30 VDC resistive; 0.3 A @ 110 VDC inductive; 1.0 A @ 30 VDC inductive.

B224BI(A): Plug-in System Sensor **isolator** detector base. Maximum 25 devices between isolator bases (see DF-52389).

ACCESSORIES

F110: Retrofit flange to convert B210LP(A) to match the B350LP(A) profile, or to convert older high-profile bases to low-profile.

F110BP: Bulk pack of F110; package contains 15.

F210: Replacement flange for B210LP(A) base.

RA100Z(A): Remote LED annunciator. 3 – 32 VDC. Mounts to a U.S. single-gang electrical box. For use with B501(A) and B210LP(A) bases only.

SMB600: Surface mounting kit

M02-04-00: Test magnet.

M02-09-00: Test magnet with telescoping handle.

XR2B: Detector removal tool. Allows installation and/or removal of detector heads from bases in high ceiling applications.

XP-4: Extension pole for XR2B. Comes in three 5-foot (1.524 m) sections.

T55-127-010: Detector removal tool without pole.

BCK-200B: Black detector covers for use with SD355(A) only; box of 10.

WCK-200B: White detector covers for use with SD355(A) only; box of 10.

FireLite® Alarms is a registered trademark of Honeywell International Inc. ©2015 by Honeywell International Inc. All rights reserved. Unauthorized use of this document is strictly prohibited.



This document is not intended to be used for installation purposes.
We try to keep our product information up-to-date and accurate.
We cannot cover all specific applications or anticipate all requirements.
All specifications are subject to change without notice.

For more information, contact Fire•Lite Alarms. Phone: (800) 627-3473, FAX: (877) 699-4105.
www.firelite.com



Indoor Selectable-Output Strobes and Horn Strobes for Ceiling Applications

System Sensor L-Series audible visible notification products are rich with features guaranteed to cut installation times and maximize profits with lower current draw and modern aesthetics.



Features

- Plug-in design with minimal intrusion into the back box
- Tamper-resistant construction
- Automatic selection of 12- or 24-volt operation at 15 and 30 candela
- Field-selectable candela settings on ceiling units: 15, 30, 75, 95, 115, 150, and 177
- Horn rated at 88+ dBA at 16 volts
- Rotary switch for horn tone and two volume selections
- Universal mounting plate for ceiling units
- Mounting plate shorting spring feature checks wiring continuity before device installation
- Electrically Compatible with legacy SpectrAlert and SpectrAlert Advance devices
- Compatible with MDL3 sync module
- Listed for ceiling mounting only

The System Sensor L-Series offers the most versatile and easy-to-use line of horns, strobes, and horn strobes in the industry with lower current draws and modern aesthetics. With white and red plastic housings, wall and ceiling mounting options, System Sensor L-Series can meet virtually any application requirement.

The entire L-Series product line of ceiling-mount strobes and horn strobes include a variety of features that increase their application versatility while simplifying installation. All devices feature a plug-in design with minimal intrusion into the back box, making installations fast and foolproof while virtually eliminating costly and time-consuming ground faults.

To further simplify installation, the L-Series utilizes a universal mounting plate so installers can mount them to a wide array of back boxes. With an onboard shorting spring, installers can test wiring continuity before the device is installed.

Installers can also easily adapt devices to suit a wide range of application requirements using field-selectable candela settings, automatic selection of 12- or 24-volt operation, and a rotary switch for horn tones with two volume selections.

Agency Listings



FM approved except
for ALERT models
3057383



7125-1653 0504
7135-1653 0503

L-Series Specifications

Architect/Engineer Specifications

General

L-Series ceiling-mount strobes and horn strobes shall mount to a standard 4 × 4 × 1½-inch back box, 4-inch octagon back box, or double-gang back box. Two-wire products shall also mount to a single-gang 2 × 4 × 17/8-inch back box. A universal mounting plate shall be used for mounting ceiling and wall products. The notification appliance circuit wiring shall terminate at the universal mounting plate. Also, L-Series products, when used with the Sync•Circuit™ Module accessory, shall be powered from a non-coded notification appliance circuit output and shall operate on a nominal 12 or 24 volts. When used with the Sync•Circuit Module, 12-volt-rated notification appliance circuit outputs shall operate between 8.5 and 17.5 volts; 24-volt-rated notification appliance circuit outputs shall operate between 16.5 and 33 volts. Indoor L-Series products shall operate between 32 and 120 degrees Fahrenheit from a regulated DC or full-wave rectified unfiltered power supply. Ceiling strobes and horn strobes shall have field-selectable candela settings including 15, 30, 75, 95, 115, 150, and 177.

Strobe

The strobe shall be a System Sensor L-Series Model _____ listed to UL 1971 and shall be approved for fire protective service. The strobe shall be wired as a primary-signaling notification appliance and comply with the Americans with Disabilities Act requirements for visible signaling appliances, flashing at 1 Hz over the strobe's entire operating voltage range. The strobe light shall consist of a xenon flash tube and associated lens/reflector system.

Horn Strobe Combination

The horn strobe shall be a System Sensor L-Series Model _____ listed to UL 1971 and UL 464 and shall be approved for fire protective service. The horn strobe shall be wired as a primary-signaling notification appliance and comply with the Americans with Disabilities Act requirements for visible signaling appliances, flashing at 1 Hz over the strobe's entire operating voltage range. The strobe light shall consist of a xenon flash tube and associated lens/reflector system. The horn shall have two audibility options and an option to switch between a temporal three pattern and a non-temporal (continuous) pattern. These options are set by a multiple position switch. The horn on horn strobe models shall operate on a coded or non-coded power supply.

Synchronization Module

The module shall be a System Sensor Sync•Circuit model MDL3 listed to UL 464 and shall be approved for fire protective service. The module shall synchronize L-Series strobes at 1 Hz and horns at temporal three. Also, while operating the strobes, the module shall silence the horns on horn strobe models over a single pair of wires. The module shall mount to a 4 11/16 × 4 11/16 × 2 1/8-inch back box. The module shall also control two Style Y (class B) circuits or one Style Z (class A) circuit. The module shall synchronize multiple zones. Daisy chaining two or more synchronization modules together will synchronize all the zones they control. The module shall not operate on a coded power supply.

Physical/Electrical Specifications

Standard Operating Temperature	32°F to 120°F (0°C to 49°C)
Humidity Range	10 to 93% non-condensing
Strobe Flash Rate	1 flash per second
Nominal Voltage	Regulated 12 VDC or regulated 24 DC/FWR ¹
Operating Voltage Range²	8 to 17.5 V (12 V nominal) or 16 to 33 V (24 V nominal)
Operating Voltage Range (MDL3)	8.5 to 17.5V (12 V nominal) or 16.5 to 33 V (24V nominal)
Input Terminal Wire Gauge	12 to 18 AWG
Ceiling-Mount Dimensions (including lens)	6.8" diameter × 2.5" high (173 mm diameter × 64 mm high)
Ceiling-Mount Surface Mount Back Box Skirt Dimensions (SBBCL, SBBCLW)	6.9" diameter × 3.4" high (175 mm diameter × 86 mm high)

Notes:

1. Full Wave Rectified (FWR) voltage is a non-regulated, time-varying power source that is used on some power supply and panel outputs.
2. P, S, PC, and SC products will operate at 12 V nominal only for 15 and 30 cd.

UL Current Draw Data

UL Max. Strobe Current Draw (mA RMS)				
Candela Range	Candela	8-17.5 Volts		16-33 Volts
		DC	DC	FWR
Candela Range	15	87	41	60
	30	153	63	86
	75	N/A	111	142
	95	N/A	134	164
	115	N/A	158	191
	150	N/A	189	228
	177	N/A	226	264

UL Max. Horn Current Draw (mA RMS)				
Sound Pattern	dB	8-17.5 Volts		16-33 Volts
		DC	DC	FWR
Temporal	High	39	44	54
Temporal	Low	28	32	54
Non-Temporal	High	43	47	54
Non-Temporal	Low	29	32	54
3.1 KHz Temporal	High	39	41	54
3.1 KHz Temporal	Low	29	32	54
3.1 KHz Non-Temporal	High	42	43	54
3.1 KHz Non-Temporal	Low	28	29	54
Coded	High	43	47	54
3.1 KHz Coded	High	42	43	54

UL Max. Current Draw (mA RMS), Ceiling Horn Strobe, Candela Range (15-177 cd)									
DC Input	8-17.5 Volts			16-33 Volts					
	15cd	30cd	15cd	30cd	75cd	95cd	115cd	150cd	177cd
Temporal High	103	167	71	90	143	165	187	217	254
Temporal Low	96	165	54	71	137	161	185	211	249
Non-Temporal High	106	173	71	90	141	165	187	230	273
Non-Temporal Low	95	166	54	71	124	161	170	216	258
3.1K Temporal High	111	164	69	94	147	163	184	229	257
3.1K Temporal Low	103	163	54	88	143	155	185	212	252
3.1K Non-Temporal High	111	172	69	94	144	164	202	229	271
3.1K Non-Temporal Low	103	169	54	88	131	155	187	217	259

FWR Input	16-33 Volts						
	15cd	30cd	75cd	95cd	115cd	150cd	177cd
Temporal High	107	135	179	198	223	254	286
Temporal Low	78	101	151	172	199	229	262
Non-Temporal High	107	135	179	198	223	254	286
Non-Temporal Low	78	101	151	172	199	229	262
3.1K Temporal High	108	135	179	200	225	255	289
3.1K Temporal Low	79	101	150	171	196	229	260
3.1K Non-Temporal High	108	135	179	200	225	255	289
3.1K Non-Temporal Low	79	101	150	171	196	229	260

Horn Strobe Tones and Sound Output Data

Horn Strobe Output (dBA)					
Switch Position	Sound Pattern	dB	8-17.5	16-33	FWR
			Volts	Volts	
			DC	DC	
1	Temporal	High	84	89	89
2	Temporal	Low	75	83	83
3	Non-Temporal	High	85	90	90
4	Non-Temporal	Low	76	84	84
5	3.1 KHz Temporal	High	83	88	88
6	3.1 KHz Temporal	Low	76	82	82
7	3.1 KHz Non-Temporal	High	84	89	89
8	3.1 KHz Non-Temporal	Low	77	83	83

L-Series Dimensions

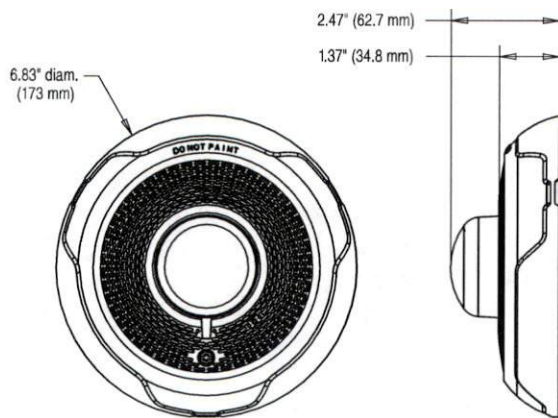

Ceiling-Mount Horn Strobes

A0545-00

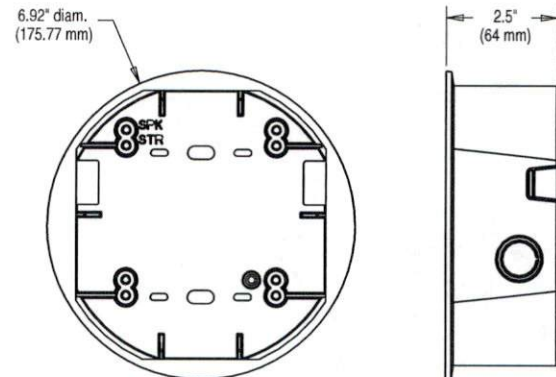

Ceiling Surface Mount Back Box

A0546-00

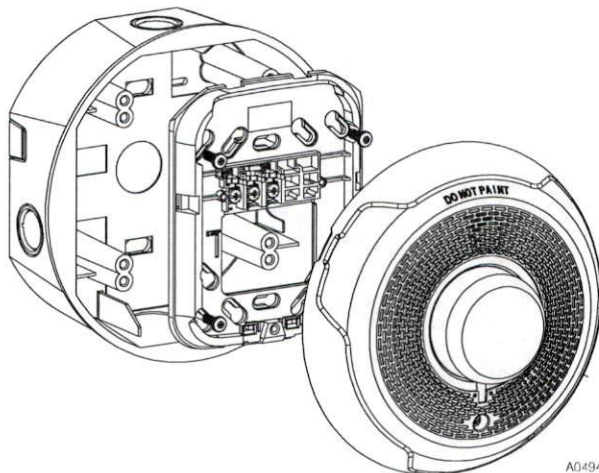

2-Wire Ceiling Mount Horn Strobes
with Ceiling Surface Mount Back Box

A0494-01

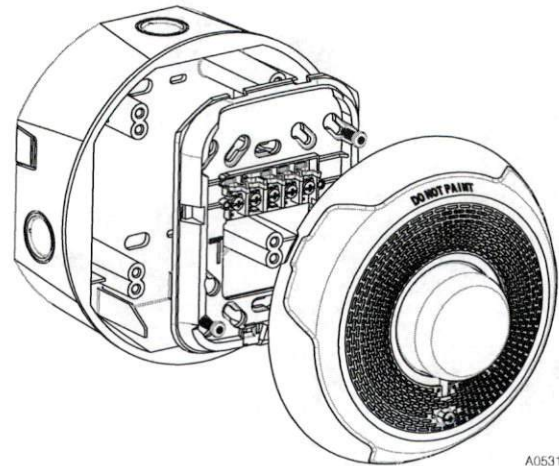

4-Wire Ceiling Mount Horn Strobes
with Ceiling Surface Mount Back Box

A0531-01

L-Series Ordering Information

Model	Description
Ceiling Horn Strobes	
PC2RL	2-Wire, Horn Strobe, Red
PC2WL	2-Wire, Horn Strobe, White
PC4RL	4-Wire, Horn Strobe, Red
PC4WL	4-Wire, Horn Strobe, White

Model	Description
Ceiling Strobes	
SCRL	Strobe, Red
SCWL	Strobe, White
SCWL-CLR-ALERT	Strobe, White, ALERT
Accessories	
TRC-2	Universal Ceiling Trim Ring Red
TRC-2W	Universal Ceiling Trim Ring White
SBBCRL	Ceiling Surface Mount Back Box, Red
SBBCWL	Ceiling Surface Mount Back Box, White

For a ceiling-listed horn-only device, see AVDS865 "Indoor Selectable-Output Horns, Strobes, and Horn Strobes for Wall Applications".



3825 Ohio Avenue • St. Charles, IL 60174
Phone: 800-SENSOR2 • Fax: 630-377-6495

©2017 System Sensor.
Product specifications subject to change without notice. Visit systemsensor.com
for current product information, including the latest version of this data sheet.
AVDS868-02 • 12/01/2017

SpectrAlert® Advance

Selectable Output Notification Appliances



Audio/Visual Devices

General

System Sensor® SpectrAlert® Advance selectable-output horns, strobes and horn/strobes are rich with features guaranteed to cut installation times and maximize profits. The SpectrAlert Advance series of notification appliances is designed to simplify your installations, with features such as: plug-in designs, instant feedback messages to ensure correct installation of individual devices, and eleven field-selectable candela settings for wall and ceiling strobes and horn/strobes.

More specifically, when installing Advance products, first attach a universal mounting plate to a four-inch square, four-inch octagon, or double-gang junction box. The two-wire mounting plate attaches to a single-gang junction box.

Then, connect the notification appliance circuit wiring to the SEMS terminals on the mounting plate.

Finally, attach the horn, strobe, or horn/strobe to the mounting plate by inserting the product's tabs in the mounting plate's grooves. The device will rotate into position, locking the product's pins into the mounting plate's terminals. The device will temporarily hold in place with a catch until it is secured with a captured mounting screw.

SpectrAlert Advance products allow you to choose:

- 12 or 24 volts.
- 15, 15/75, 30, 75, 95, 110, 115, 135, 150, 177, or 185 candela by way of a rear-mounted slide switch and front viewing window.
- Horn tones and volume by way of a rotary switch.
- The SpectrAlert Advance series includes outdoor notification appliances. Outdoor strobes and horn/strobes (two-wire and four-wire) are available for wall or ceiling. Outdoor horns are available for wall only. All System Sensor outdoor products are rated between -40°F and 151°F (-40°C and 66°C) in wet or dry applications.

Models available:

- Indoor wall-mount: horn, strobe, 2-wire horn/strobe, 4-wire horn/strobe.
- Indoor ceiling-mount: strobe, 2-wire horn/strobe, 4-wire horn/strobe.
- Outdoor wall-mount: horn, strobe, 2-wire horn/strobe, 4-wire horn/strobe.
- Outdoor ceiling-mount: strobe, 2-wire horn/strobe, 4-wire horn/strobe.

Features

- Plug-in design.
- Same mounting plate for wall- and ceiling-mount units.
- Shorting spring on mounting plate for continuity check before installation.
- Captive mounting screw.
- Tamper-resistance capability.
- Field-selectable candela settings on wall and ceiling units: 15, 15/75, 30, 75, 95, 110, 115, 135, 150, 177, 185.
- Automatic selection of 12 or 24 volt operation at 15 and 15/75 candela.
- Outdoor wall and ceiling products.



Indoor Ceiling
Horn/Strobe



Outdoor Ceiling
Strobe



Indoor Wall
Horn/Strobe



Indoor Ceiling
Strobe

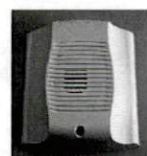

Indoor Wall
Horn



Outdoor Wall
Strobe

- Outdoor products rated from -40°F and 151°F (-40°C and 66°C).
- Outdoor products rainproof per UL50 (NEMA 3R) and weatherproof per NEMA 4X, IP56
- Minimal intrusion into the backbox.
- Horn rated at 88+ dbA at 16 volts.
- Rotary switch for tone selection.
- Three horn volume settings.
- Electrically compatible with existing SpectrAlert products.

Engineering Specifications

SpectrAlert Advance horns, strobes, and horn/strobes shall mount to a standard 4.0" x 4.0" x 1.5" (10.16 x 10.16 x 3.81 cm) backbox, 4.0" (10.16 cm) octagonal backbox, or a double-gang backbox. Two-wire products shall also mount to a single-gang 2.0" x 4.0" x 1.875" (5.08 x 10.16 x 4.763 cm) backbox. A universal mounting plate shall be used for mounting ceiling and wall products. The notification appliance circuit wiring shall terminate at the universal mounting plate. Also, SpectrAlert Advance products, when used with the SyncCircuit™ Module accessory, shall be powered from a non-coded notification appliance circuit output and shall operate on a nominal 12 or 24 volts. When used with the SyncCircuit Module, 12-volt rated notification appliance circuit outputs shall operate between 9 and 17.5 volts; 24-volt rated notification appliance circuit outputs shall operate between 17 and 33 volts. Indoor SpectrAlert Advance products shall operate between 32°F and 120°F (0°C and 49°C) from a regulated DC, or full-wave-rectified, unfiltered power supply. Strobes and horn/strobes shall have field-selectable candela settings including 15, 15/75, 30, 75, 95, 110, 115, 135, 150, 177, 185.

STROBE

The strobe shall be a System Sensor SpectrAlert Advance Model _____ listed to UL 1971 and shall be approved for fire protective service. The strobe shall be wired as a primary-signaling notification appliance and comply with the Americans with Disabilities Act requirements for visible signaling appliances, flashing at 1 Hz over the strobe's entire operating voltage range. The strobe light shall consist of a xenon flash tube and associated lens/reflector system.

HORN/STROBE COMBINATION

The horn/strobe shall be a System Sensor SpectrAlert Advance Model _____ listed to UL 1971 and UL 464 and shall be approved for fire protective service. The horn/strobe shall be wired as a primary-signaling notification appliance and comply with the Americans with Disabilities Act requirements for visible signaling appliances, flashing at 1 Hz over the strobe's entire operating voltage range. The strobe light shall consist of a xenon flash tube and associated lens/reflector system. The horn shall have three audibility options and an option to switch between a Temporal 3 pattern and a Non-Temporal (continuous) pattern. These options are set by a multiple position switch. On four-wire products, the strobe shall be powered independently of the sounder. The horn on horn/strobe models shall operate on a coded or non-coded power supply.

OUTDOOR PRODUCTS

SpectrAlert Advance outdoor horns, strobes and horn/strobes shall be listed for outdoor use by UL and shall operate between -40°F and 151°F (-40°C and 66°C). The products shall be listed for use with a System Sensor outdoor/weather-proof backbox with half-inch and three-fourths-inch conduit entries.

SYNCHRONIZATION MODULE

The module shall be a System Sensor Sync•Circuit MDL3R or MDL3W listed to UL 464 and shall be approved for fire protective service. The module shall synchronize SpectrAlert strobes at 1 Hz and horns at Temporal 3. Also, while operating the strobes, the module shall silence the horns on horn/strobe models over a single pair of wires. The module shall mount to a 4.688" x 4.688" x 2.125" (11.906 x 11.906 x 5.398 cm) backbox. The module shall also control two Style Y (class B) circuits or one Style Z (Class A) circuit. The module shall synchronize multiple zones. Daisy-chaining two or more synchronization modules together will synchronize all the zones they control. The module shall not operate on a coded power supply.

Strobe Current Draw, UL Maximum (mA RMS)

Candela	8 – 17.5 V		16 – 33 V		
	DC	FWR	DC	FWR	
Standard Candela Range	15	123	128	66	71
	15/75	142	148	77	81
	30	NA	N/A	94	96
	75	NA	NA	158	153
	95	NA	NA	181	176
	110	NA	NA	202	195
	115	NA	NA	210	205
High Candela Range	135	NA	NA	228	207
	150	NA	NA	246	220
	177	NA	NA	281	251
	185	NA	NA	286	258

Operating Specifications

- **Standard operating temperature:** 32°F to 120°F (0°C to 49°C).
- **K Series operating temperature:** -40°F to 151°F (-40°C to 66°C).
- **Humidity range:** 10% to 93% non-condensing (indoor products).
- **Strobe flash rate:** 1 flash per second.
- **Nominal voltage:** regulated 12 VDC/FWR or regulated 24 VDC/FWR. **NOTE:** Full Wave Rectified (FWR) voltage is a non-regulated, time-varying power source that is used on some power supply and panel outputs.
- **Operating voltage range:** 8 V to 17.5 V (12 V nominal); or 16 V to 33 V (24 V nominal). **NOTE:** P, S, PC, and SC products will operate at 12 V nominal only for 15 cd and 15/75 cd.
- **Input terminal wire gauge:** 12 to 18 AWG (3.31 to 0.821 mm²).
- **Ceiling-mount dimensions (including lens):** 6.8" diameter x 2.5" deep (17.3 cm diameter x 6.4 cm deep).
- **Wall-mount dimensions (including lens):** 5.6" H x 4.7" W x 2.5" D (14.2 cm H x 11.9 cm W x 6.4 cm D).
- **Horn dimensions:** 5.6" H x 4.7" W x 1.3" D (14.2 cm H x 11.9 cm W x 3.3 cm D).

Agency Listings and Approvals

The listings and approvals below apply to SpectrAlert Advance Selectable Output Notification Devices. In some cases, certain modules may not be listed by certain approval agencies, or listing may be in process. Consult factory for latest listing status.

- **UL Listed:** S4011 (HR_, HW_, P2_, P4_, PC2_, PC4_ models); S5512 (models SCR, SCRH, SCW, SCWH, SR, SRH, SW, SWH); S3593 (SCRHK, SCRK, SRHK, SRK).
- **ULC Listed:** S4011 (HRA, HRKA); S5512 (typically "A" models, with exception of outdoor strobes). See Canadian data sheet for listings and specifications.
- **FM approved**
- **MEA:** 452-05-E
- **CSFM:** 7125-1653:0186 (SCR, SCRH, SCW, SCWH, SR, SRH, SW, SWH); 7300-1653:0188 (P2_, P4_, PC2_, PC4_ modules); 7135-1653:0189 (HR, HRK, HW); 7300-1653:0187 (SCRHK, SCRK, SRHK, SRK).

Horn Current Draw, UL Maximum (mA RMS)

Sound Pattern	dB	8 – 17.5 V		16 – 33 V	
		DC	FWR	DC	FWR
Temporal	High	57	55	69	75
Temporal	Medium	44	49	58	69
Temporal	Low	38	44	44	48
Non-temporal	High	57	56	69	75
Non-temporal	Medium	42	50	60	69
Non-temporal	Low	41	44	50	50
Coded	High	57	55	69	75
Coded	Medium	44	51	56	69
Coded	Low	40	46	52	50

Horn and Horn/Strobe Rotary Switch Setting

Setting	Repetition Rate	dB Level
1	Temporal horn	High
2	Temporal horn	Medium
3	Temporal horn	Low
4	Normal horn	High
5	Normal horn	Medium
6	Normal horn	Low
7*	Externally coded	High
8*	Externally coded	Medium
9*	Externally coded	Low

*NOTE: Settings 7, 8, and 9 are not available on 2-wire horn/strobe.

Horn and Horn/Strobe Output (dBA)

Switch Position	Sound Pattern	dB	8 – 17.5 V		16 – 33 V	
			DC	FW R	DC	FW R
1	Temporal	High	78	78	84	84
2	Temporal	Medium	74	74	80	80
3	Temporal	Low	71	73	76	76
4	Non-temporal	High	82	82	88	88
5	Non-temporal	Medium	78	78	85	85
6	Non-temporal	Low	75	75	81	81
7*	Coded	High	82	82	88	88
8*	Coded	Medium	78	78	85	85
9*	Coded	Low	75	75	81	81

*NOTE: Settings 7, 8, and 9 are not available on 2-wire horn/strobe.

Two-Wire Horn/Strobe, STANDARD Candela Range (15 – 115 cd), UL Maximum Current Draw (mA RMS)

Input, Sound Pattern, dB Level	8 – 17.5 V		16 – 33 V						
	15	15/75	15	15/75	30	75	95	110	115
DC Input, Temporal, High	137	147	79	90	107	176	194	212	218
DC Input, Temporal, Medium	132	144	69	80	97	157	182	201	210
DC Input, Temporal, Low	132	143	66	77	93	154	179	198	207
DC Input, Non-temporal, High	141	152	91	100	116	176	201	221	229
DC Input, Non-temporal, Medium	133	145	75	85	102	163	187	207	216
DC Input, Non-temporal, Low	131	144	68	79	96	156	182	201	210
FWR Input, Temporal, High	136	155	88	97	112	168	190	210	218
FWR Input, Temporal, Medium	129	152	78	88	103	160	184	202	206
FWR Input, Temporal, Low	129	151	76	86	101	160	184	194	201
FWR Input, Non-temporal, High	142	161	103	112	126	181	203	221	229
FWR Input, Non-temporal, Medium	134	155	85	95	110	166	189	208	216
FWR Input, Non-temporal, Low	132	154	80	90	105	161	184	202	211

Two-Wire Horn/Strobe, HIGH Candela Range (135 – 185 cd), UL Maximum Current Draw (mA RMS)

DC Input	16 – 33 V				FWR Input	16 – 33 V			
	135	150	177	185		135	150	177	185
DC, Temporal, High	245	259	290	297	FWR, Temporal, High	215	231	258	265
DC, Temporal, Medium	235	253	288	297	FWR, Temporal, Medium	209	224	250	258
DC, Temporal, Low	232	251	282	292	FWR, Temporal, Low	207	221	248	256
DC, Non-temporal, High	255	270	303	309	FWR, Non-temporal, High	233	248	275	281
DC, Non-temporal, Medium	242	259	293	299	FWR, Non-temporal, Medium	219	232	262	267
DC, Non-temporal, Low	238	254	291	295	FWR, Non-temporal, Low	214	229	256	262

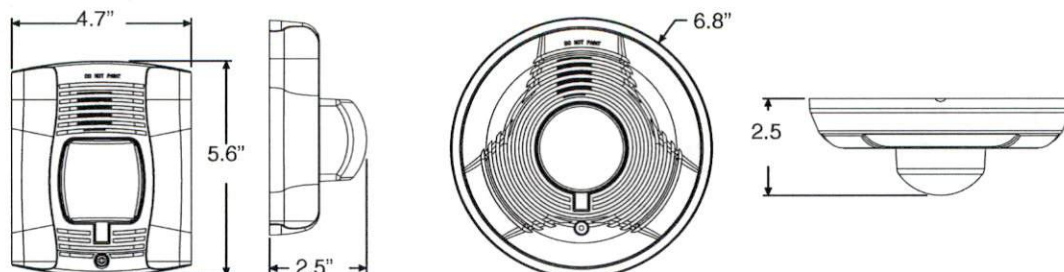

7087dim12009.tif

Ordering Information

Model	Description	Model	Description
WALL HORN/STROBES		CEILING HORN/STROBES	
P2R	2-wire horn/strobe, standard cd, red.	PC2R	2-wire horn/strobe, standard cd, red.
P2RH	2-wire horn/strobe, high cd, red.	PC2RH	2-wire horn/strobe, high cd, red.
P2RK	2-wire horn/strobe, standard cd, red, outdoor.	PC2RK	2-wire horn/strobe, standard cd, red, outdoor.
P2RHK	2-wire horn/strobe, high cd, red, outdoor.	PC2RHK	2-wire horn/strobe, high cd, red, outdoor.
P2W	2-wire horn/strobe, standard cd, white.	PC2W	2-wire horn/strobe, standard cd, white.
P2WH	2-wire horn/strobe, high cd, white.	PC2WH	2-wire horn/strobe, high cd, white.
P4R	4-wire horn/strobe, standard cd, red.	PC4R	4-wire horn/strobe, standard cd, red.
P4RH	4-wire horn/strobe, high cd, red.	PC4RH	4-wire horn/strobe, high cd, red.
P4RK	4-wire horn/strobe, standard cd, red, outdoor.	PC4RK	4-wire horn/strobe, standard cd, red, outdoor.
P4RHK	4-wire horn/strobe, high cd, red, outdoor.	PC4RHK	4-wire horn/strobe, high cd, red, outdoor.
P4W	4-wire horn/strobe, standard cd, white.	PC4W	4-wire horn/strobe, standard cd, white.
P4WH	4-wire horn/strobe, high cd, white.	PC4WH	4-wire horn/strobe, high cd, white.
WALL STROBES		CEILING STROBES	
SR	Strobe, standard cd, red.	SCR	Strobe, standard cd, red.
SRH	Strobe, high cd, red.	SCRH	Strobe, high cd, red.
SRK	Strobe, standard cd, red, outdoor.	SCRK	Strobe, standard cd, red, outdoor.
SRHK	Strobe, high cd, red, outdoor.	SCRHK	Strobe, high cd, red, outdoor.
SW	Strobe, standard cd, white.	SCW	Strobe, standard cd, white.
SWH	Strobe, high cd, white.	SCWH	Strobe, high cd, white.
ACCESSORIES		HORNS	
BBS-2A	Backbox skirt, wall, red.	HR	Horn, red.
BBSW-2A	Backbox skirt, wall, white.	HRK	Horn, red, outdoor.
BBSC-2A	Backbox skirt, ceiling, red.	HW	Horn, white.
BBSCW-2A	Backbox skirt, ceiling, white.	ACCESSORIES, continued	
SA-WBB	Weatherproof backbox, wall.	TR-HS	Trim Ring, wall, red, package of 5
SA-WBBC	Weatherproof backbox, ceiling.	TRW-HS	Trim Ring, wall, white, package of 5
WTP	Weatherproof, flush mount plate, red	TRC-HS	Trim Ring, ceiling, red, package of 5
WTPW	Weatherproof, flush mount plate, white	TRCW-HS	Trim Ring, ceiling, white, package of 5
<p>NOTE: "High cd" refers to strobes that include 135, 150, 177, and 185 candela settings. "Standard cd" refers to strobes that include 15, 15/75, 30, 75, 95, 110, and 115 candela settings.</p> <p>NOTE: For strobes and horn/strobes, add suffix "F" for French or "B" for Bilingual.</p> <p>NOTE: All outdoor models ("K(A)" suffix) include a plastic weatherproof backbox.</p> <p>NOTE: Add "-R" to models for weatherproof replacement device (no back box included). Only for use with weatherproof outdoor flush mounting plate, WTP and WTPW.</p> <p>NOTE: Add "P" to model for plain housing. (No "FIRE" marking on cover.)</p>			

Sync•Circuit™ is a trademark and SpectrAlert® is a registered trademark of Honeywell International Inc.
 ©2011 by Honeywell International Inc. All rights reserved. Unauthorized use of this document is strictly prohibited.



This document is not intended to be used for installation purposes.
 We try to keep our product information up-to-date and accurate.
 We cannot cover all specific applications or anticipate all requirements.
 All specifications are subject to change without notice.



Made in the U.S. A.

For more information, contact Fire•Lite Alarms. Phone: (800) 627-3473, FAX: (877) 699-4105.
www.firelite.com

CRF-300(A)

Relay Module

Addressable Devices

General

The **CRF-300(A)** Addressable Relay Module provides the system with a dry-contact output for activating a variety of auxiliary devices, such as fans, door holders, dampers, control equipment, etc. Addressability allows the dry contact to be activated through panel programming, on a select basis.

LiteSpeed™ is a communication protocol developed by Fire-Lite Engineering that greatly enhances the speed of communication between analog intelligent devices. Intelligent devices communicate in a grouped fashion. If one of the devices within the group has new information, the panel CPU stops the group poll and concentrates on single points. The net effect is response speed greater than five times that of other designs.

Features

- Built-in type identification automatically identifies these devices to the control panel.
- Internal circuitry and relay powered directly by two-wire SLC loop.
- Integral LED "blinks" green each time a communication is received from the control panel and turns on in steady red when activated.
- High noise immunity (EMF/RFI).
- Wide viewing angle of LED.
- SEMS screws with clamping plates for wiring ease.
- Direct-dial entry of address: 01– 159 for MS-9600(A) series panels, 01 – 99 on MS-9200UDLS(A) and MS-9050UD(A).

Applications

The CRF-300(A) may be programmed to operate dry contacts for door holders, Air Handling Unit shutdown, etc., and to reset four-wire smoke detector power.

Construction

- The face plate is made of off-white heat-resistant plastic.
- Controls include two rotary switches for direct-dial entry of address setting.
- The CRF-300(A) is configured for a single Class B (Style Y) or Class A (Style Z) Notification Appliance Circuit.
- The CRF-300(A) provides two Form-C dry contacts that switch together.

Operation

Each CRF-300(A) uses one of the addresses on a SLC loop. It responds to regular polls from the control panel and reports its type and status, including the open/normal/short status of its Notification Appliance Circuit (NAC). The LED blinks with each poll received. On command, it activates its internal relay.

NOTE: Open/short supervision is suspended with the CRF-300.

Rotary switches set a unique address for each module. The address may be set before or after mounting. The built-in TYPE CODE (not settable) will identify the module to the control panel, so as to differentiate between a control module and a relay module.

CRF-300(A)

Specifications

Normal operating voltage: 15 to 32 VDC.

Maximum SLC current draw: 6.5 mA (LED on).

Average operating current: 230 µA direct poll (CLIP mode), 255 µA group poll (LiteSpeed mode) with LED flashing.

EOL resistance: not used.

Temperature range: 32°F to 120°F (0°C to 49°C).

Humidity range: 10% to 93% non-condensing.

Dimensions: 4.5" (11.43 cm) high x 4" (10.16 cm) wide x 1.25" (3.175 cm) deep. Mounts to a 4" (10.16 cm) square x 2.125" (5.398 mm) deep box.

Relay Contact Ratings

Load Description	Application	Maximum Voltage	Current Rating
Resistive	Non-Coded	30 VDC	3.0 A
Resistive	Coded	30 VDC	2.0 A
Resistive	Non-Coded	110 VDC	0.9 A
Resistive	Non-Coded	125 VAC	0.9 A
Inductive (L/R=5ms)	Coded	30 VDC	0.5 A
Inductive (L/R=2ms)	Coded	30 VDC	1.0 A
Inductive (PF=0.35)	Non-Coded	125 VAC	0.5 A

Agency Listings and Approvals

In some cases, certain modules may not be listed by certain approval agencies, or listing may be in process. Consult factory for latest listing status.

- UL: S2424
- ULC: S2424
- FM approved
- CSFM: 7300-0075:185
- MEA: 72-01-E

Product Line Information

CRF-300(A): Intelligent addressable relay module.

: Intelligent addressable relay module, ULC listed model.

SMB500: Optional surface-mount backbox.

NOTE: For installation instructions, see document I56-1190-005 and refer to the SLC Wiring Manual, document 51309.

LiteSpeed™ is a trademark and **Fire•Lite®** Alarms is a registered trademark of Honeywell International Inc.
©2009 by Honeywell International Inc. All rights reserved. Unauthorized use of this document is strictly prohibited.

ISO 9001
CERTIFIED
ENGINEERING & MANUFACTURING
QUALITY SYSTEMS

This document is not intended to be used for installation purposes.
We try to keep our product information up-to-date and accurate.
We cannot cover all specific applications or anticipate all requirements.
All specifications are subject to change without notice.



Made in the U.S. A.

For more information, contact Fire•Lite Alarms. Phone: (800) 627-3473, FAX: (877) 699-4105.
www.firelite.com

D355PL(A)/DNRW InnovairFlex Intelligent Non-Relay Photoelectric Duct Smoke Detector

FIRE•LITE ALARMS
by Honeywell

Intelligent Addressable Devices

General

The Fire•Lite InnovairFlex® D355PL(A) intelligent non-relay photoelectric duct smoke detector and DNRW watertight non-relay photoelectric duct smoke detector feature a pivoting housing that fits both square and rectangular footprints capable of mounting to a round or rectangular duct.

DNRW duct smoke detector, with its NEMA-4 rating, is listed as a watertight, UV resistant enclosure providing protection against falling dirt, rain, and windblown dust, splashing and hose directed water, allowing operators to use the detector in the most extreme environments.

These units sense smoke in the most challenging conditions, operating in airflow speeds of 100 to 4,000 feet per minute (0.5 to 20.32 m/s), temperatures of -4°F to 158°F (-20°C to 70°C), and a humidity range of 0 to 95 percent (non-condensing.)

An improved cover design isolates the sensor head, which allows for ease of maintenance. A cover tamper feature indicates a trouble signal for a removed or improperly installed sensor cover. The Fire•Lite InnovairFlex housing provides a 3/4-inch conduit knockout and ample space to facilitate easy wiring and mounting of a relay module.

The Fire•Lite InnovairFlex duct smoke detector can be customized to meet local codes and specifications without additional wiring. The new InnovairFlex product line is compatible with all previous Innovair models, including remote test accessories.

Features

- Photoelectric, integrated low-flow technology.
- Air velocity rating from 100 ft/min to 4,000 ft/min (0.5 m/s to 20.32 m/s).
- Versatile mounting options: square or rectangular configuration.
- Broad ranges for operating temperature (-4°F to 158°F, -20°C to 70°C) and humidity (0% to 95% non-condensing).
- Patented sampling tube installs from front or back of the detector with no tools required.
- Cover tamper signal.
- Increased wiring space with a newly added 3/4" conduit knockout.
- Available space within housing to accommodate mounting of a relay module.
- Easily accessible code wheels on sensor head (sold separately).
- Clear cover for convenient visual inspection.
- Remote testing capability.
- Requires com line power only.
- Accommodates the installation of an addressable relay module, sold separately, (CRF-300) for applications requiring a Form-C relay.

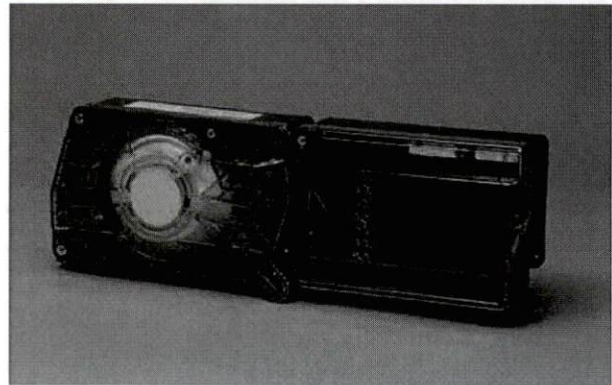

Specifications

Size: (Rectangle) 14.38 in (37 cm) Length; 5 in (12.7 cm) Width, 2.5 in (6.6 cm) Depth.

Size: (Square) 7.75 in (19.7 cm) Length; 9 in (22.9 cm) Width; 2.5 in (6.35 cm) Depth.

Weight: 1.6 lb (0.73 kg).

Operating Temperature Range: -4°F to 158°F (-20°C to 70°C).

Storage Temperature Range: -22°F to 158°F (-30°C to 70°C).

Operating Humidity Range: 0% to 95% relative humidity (non-condensing).

Air Duct Velocity: 100 to 4,000 ft/min (0.5 to 20.32 m/s).

Accessories

Fire•Lite provides system flexibility with a variety of accessories, including two remote test stations and different means of visible and audible system annunciation. As with our duct smoke detectors, all duct smoke detectors accessories are UL listed.

D355PLs and DNRWs with a date code of 0013 or higher do not require external 24VDC for remote test applications when used with a remote-test-capable detector.

ACCESSORY CURRENT LOADS AT 24 VDC

Device	Standby	Alarm
RA100Z	0mA	12 mA Max
RTS151/ RTS151KEY	0mA	12mA Max

Agency Listings and Approvals

Consult product manual for lists of compatible UL-Listed devices. In some cases, certain modules may not be listed by certain approval agencies, or listing may be in process. Consult factory for latest listing status.

- **UL:** S1059.
- **ULC:** S1059

- **CSFM:** 3242-1653:0209.
- **FM approved.**

Product Line Information

D355PL: Intelligent non-relay photoelectric low flow smoke detector housing. Includes SD355R Detector.

DNRW: Watertight intelligent non-relay photoelectric low flow duct smoke detector housing. Does not include detector head.

SD355R(A): Remote test capable addressable low-profile photoelectric smoke detector.

SD355(A): Addressable low-profile photoelectric smoke detector.

DCOIL: Remote test coil. Required for older DNR(W) duct detector housing.

DST1: Metal sampling tube duct width up to 1 ft (0.3m).

DST1.5: Metal sampling tube duct widths up to 1 ft to 2 ft (0.3 to 0.6 m).

DST3: Metal sampling tube duct widths up to 2 ft to 4 ft (0.6 to 1.2 m).

DST5: Metal sampling tube duct widths up to 4 ft to 8 ft (1.2 to 2.4 m).

DST10: Metal sampling tube duct widths up to 8 ft to 12 ft (2.4 to 3.7 m).

DH400OE-1: Weatherproof enclosure.

ETX: Metal exhaust tube duct, width 1 ft (0.3 m).

M02-04-00: Test magnet.

P48-21-00: End cap for metal sampling tubes.

RA100Z: Remote annunciator alarm LED.

RTS151: Remote test station.

RTS151KEY: Remote test station with key lock.

Important Note

- DNRW duct detector housings with a date code of 0013 or higher do not require a DCOIL or auxiliary 24 VDC for remote test applications when used with a remote test capable detector.
- DNRW duct detector housings with a date code of 0012 or earlier require a DCOIL and auxiliary 24 VDC power for remote test applications.

Fire•Lite® Alarms is a registered trademark of Honeywell International Inc. ©2012 by Honeywell International Inc. All rights reserved. Unauthorized use of this document is strictly prohibited.



This document is not intended to be used for installation purposes.
 We try to keep our product information up-to-date and accurate.
 We cannot cover all specific applications or anticipate all requirements.
 All specifications are subject to change without notice.



Made in the U.S. A.

For more information, contact Fire•Lite Alarms. Phone: (800) 627-3473, FAX: (877) 699-4105.
www.firelite.com

H355(A) Series

Intelligent Addressable Thermal Detectors

Addressable Devices

General

The Fire•Lite Alarms H355(A) Series thermal detectors are addressable sensors that use a state-of-the-art thermistor sensing circuit for fast response. These sensors provide open-area protection and are intended for use with Fire•Lite's addressable Fire Alarm Control Panels (FACPs).

The H355(A) and H355R(A) sensors provide fixed temperature alarm detection at 135°F (57°C). The H355R(A) sensor also responds to rate-of-rise conditions of greater than 15°F (8.3°C) per minute. The H355HT(A) is a fixed high-temperature detector that activates at 190°F (88°C). These thermal detectors provide addressable property protection in a variety of applications.

Two LEDs on each sensor light to provide a local, visible sensor indication. Remote LED annunciator capability is available using an optional accessory, the RA100Z.

Features

SLC loop:

- Two-wire SLC loop connection.
- Unit uses base for wiring.

Addressing:

- Addressable by device.
- Rotary, decimal addressing: 01 – 159 with MS-9600 series, 01 – 99 with MS-9200 series.

Architecture:

- Sleek, low-profile, stylish design.
- State-of-the-art thermistor technology for fast response.
- Integral communications and built-in device-type identification.
- Built-in tamper resistant feature.
- Built-in functional test switch activated by external magnet.

Operation:

- Factory preset at 135°F (57°C) for the H355(A) and H355R(A); 190°F (88°C) for the H355HT(A).
- Rate-of-rise triggers at 15°F (8.3°C) per minute for the H355R(A).
- 360°-field viewing angle of the visual alarm indicators (two bicolor LEDs). LEDs blink red in Normal condition and turn on steady red in Alarm.
- Visible LEDs "blink" every time the unit is addressed.

Mechanicals:

- Sealed against back pressure.
- SEMS screws for wiring of the separate base.
- Designed for direct-surface or electrical-box mounting.
- Plugs into separate base for ease of installation and maintenance.
- Separate base allows interchange of photoelectric, ionization and thermal sensors.

Other system features:

- Remote test feature from the panel.
- Walk test with address display.
- Low standby current.



H355(A) in B210LP(A) Base

B210-2251.jpg

- 94-5V plastic flammability rating.

Options:

- Remote LED output connection to optional RA100Z remote LED annunciator.
- Flanged surface mounting kit.

Installation

H355(A) Series plug-in intelligent thermal detectors use a detachable base to simplify installation, service and maintenance. Installation instructions are shipped with each detector.

Mount base (all base types) on an electrical backbox which is at least 1.5" (3.81 cm) deep. For a chart of compatible junction boxes, see DF-60059.

NOTE: Because of the inherent supervision provided by the SLC loop, end-of-line resistors are not required. Wiring "T-taps" or branches are permitted for Style 4 (Class "B") wiring only.

Applications

Use thermal detectors for protection of property.

Construction

These detectors are constructed of off-white fire-resistant plastic. The H355(A) Series plug-in intelligent thermal detectors are designed to commercial standards and offer an attractive appearance.

Operation

Each H355(A) Series detector uses one of 159 (MS-9600 series) or 99 (MS-9200 series) possible addresses on a control panel SLC loop. It responds to regular polls from the control panel and reports its type and the status. If it receives a test command from the panel (or a local magnet test), it stimulates its electronics and reports an alarm. It blinks its LEDs when polled and turns the LEDs on when commanded by the panel. The H355(A) Series offers features and performance that represent the latest in thermal detector technology.

Specifications

Size: 2.1" (5.3 cm) high; base determines diameter.

- **B210LP(A):** 6.1" (15.5 cm) diameter.
- **B501(A):** 4.1" (10.4 cm) diameter.
- **B200SR(A):** 6.875" (17.46 cm) diameter.
- **B224RB(A):** 6.2" (15.748 cm) diameter.

Shipping weight: 4.8 oz. (137 g).

Installation temperature:

- H355(A), H355R(A): –4°F to 100°F (–20°C to 38°C).
- H355HT(A): –4°F to 150°F (–20°C to 66°C).

Humidity range: 10% to 93% relative humidity (noncondensing).

Voltage range: 15 to 32 VDC peak.

Standby current: 300 µA @ 24 VDC (one communication every five seconds with LED blink enabled).

LED current: 6.5 mA @ 24 VDC.

Mounting: B210LP(A) flanged base, included. See "Product Line Information: Intelligent Bases" if using a different base.

Fixed-temperature setpoint: 135°F (57°C) for the H355(A) and H355R(A); 190°F (88°C) for the H355HT(A).

Rate-of-rise detection: responds to greater than 15°F (8.3°C) per minute.

Listings and Approvals

Listings and approvals below apply to the H355(A) Series detectors. In some cases, certain modules may not be listed by certain approval agencies, or listing may be in process. Consult factory for latest listing status.

- **UL Listed:** S2517.
- **ULC Listed** (models H355A, H355RA, H355HTA).
- **CSFM approved:** 7270-0075:0195.
- **FM approved.**

Product Line Information

NOTE: "A" suffix indicates ULC Listed model.

H355: Intelligent thermal sensor; 135° F (57° C); B210LP base included.

H355A: Same as H355 but with ULC Listing; B210LPA base included.

H355R: Same as H355 with *rate-of-rise* feature; B210LP base included.

H355RA: Same as H355R but with ULC Listing; B210LPA base included.

H355HT: Intelligent fixed high-temperature thermal detector; 190° F (88° C); B210LP base included.

H355HTA: Same as H355HT but with ULC Listing; B210LPA base included.

INTELLIGENT BASES

NOTE: "A" suffix indicates ULC Listed model.

NOTE: The detector's plug-in base can be changed off for special applications. For details about intelligent bases and their mounting, see DF-60059.

B210LP(A): Plug-in detector base (included); standard U.S. flanged low-profile mounting base.

B210LPBP: Bulk pack of B210LP; package contains 10.

B501(A): Standard European flangeless mounting base.

B501BP: Bulk pack of B501; package contains 10.

B200SR(A): Intelligent sounder base capable of producing sound output with ANSI Temporal 3 or continuous tone. Replaces B501BH series bases in retrofit applications.

B224RB(A): Plug-in System Sensor **relay** base. Screw terminals: up to 14 AWG (2.0 mm²). Relay type: Form-C. Rating: 2.0 A @ 30 VDC resistive; 0.3 A @ 110 VDC inductive; 1.0 A @ 30 VDC inductive.

B224BI(A): Plug-in System Sensor **isolator** detector base. Maximum 25 devices between isolator bases (*see DF-52389*).

ACCESSORIES

F110: Retrofit flange to convert B210LP(A) to match the B350LP(A) profile, or to convert older high-profile bases to low-profile.

F110BP: Bulk pack of F110; package contains 15.

F210: Replacement flange for B210LP(A) base.

RA100Z(A): Remote LED annunciator. 3 – 32 VDC. Mounts to a U.S. single-gang electrical box. For use with B501(A) and B210LP(A) bases only.

SMB600: Surface mounting kit

M02-04-00: Test magnet.

M02-09-00: Test magnet with telescoping handle.

XR2B: Detector removal tool. Allows installation and/or removal of detector heads from bases in high ceiling applications.

XP-4: Extension pole for XR2B. Comes in three 5-foot (1.524 m) sections.

T55-127-010: Detector removal tool without pole.

Fire•Lite® Alarms is a registered trademark of Honeywell International Inc.
©2013 by Honeywell International Inc. All rights reserved. Unauthorized use of this document is strictly prohibited.



This document is not intended to be used for installation purposes.
We try to keep our product information up-to-date and accurate.
We cannot cover all specific applications or anticipate all requirements.
All specifications are subject to change without notice.



For more information, contact Fire•Lite Alarms. Phone: (800) 627-3473, FAX: (877) 699-4105.
www.firelite.com

BAT Series Batteries

Sealed Lead-Acid



Power Supplies/Accessories

General

BAT Series Batteries are Power Sonic brand batteries. BAT Series (or Power Sonic brand) batteries are recommended for secondary power or backup power for all Fire•Lite fire alarm control equipment.

Features

- Provide secondary power for control panels.
- Sealed and maintenance-free.
- Overcharge protected.
- Easy handling with leakproof construction.
- Ruggedly constructed, high-impact case (ABS, polystyrene, or polypropylene, depending on models).
- Long service life.
- Compact design.

Agency Listings and Approvals

The listings and approvals below apply to BAT Series Batteries. In some cases, certain modules may not be listed by certain approval agencies, or listing may be in process. Consult factory for latest listing status.

- **UL Recognized Components:** MH20845 (*Power-Sonic*)

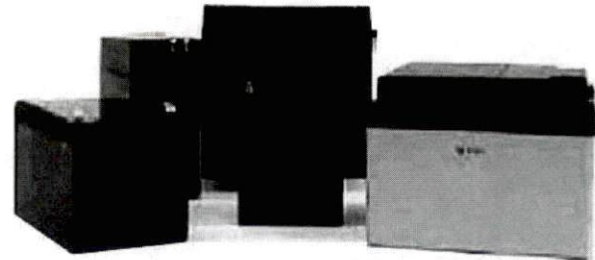

6933cov.jpg

Ordering Information

BAT-1250-BP: 10-unit bulk pack of BAT-1250 (12 V 5 AH)

BAT-1270-BP: 5-unit bulk pack of BAT-1270 (12 V 7 AH)

BAT-12120-BP: 4-unit bulk pack of BAT-12120 (12V 12 AH)

BAT-12180-BP: 2-unit bulk pack of BAT-12180 (12 V 18 AH)

BAT-12260-BP: 2-unit bulk pack of BAT-12260 (12 V 26 AH)

BAT-12550: single battery (12 V 55 AH)

BAT-121000: single battery (12 V 100 AH)

Part Number Reference & Specifications

Part Number	Power Sonic Part Number	Battery Description			DIMENSIONS									
		Nominal Voltage V	Nominal Capacity @ 20 hr. rate A.H.		Width		Depth		Height		Height over terminal		Weight	
					in.	mm	in.	mm	in.	mm	in.	mm	lb.	kg.
BAT-1250	PS-1250	12	5	sealed	3.54	90	2.76	70	4.02	102	4.21	107	4.1	1.9
BAT-1270	PS-1270	12	7	sealed	5.95	151	2.56	65	3.7	94	3.86	98	4.8	2.18
BAT-12120	PS-12120	12	12	sealed	5.95	151	3.86	98	3.7	94	3.94	100	7.92	3.59
BAT-12180	PS-12180	12	18	sealed	7.13	181	2.99	76	6.57	167	6.57	167	12.6	5.8
BAT-12260	PS-12260	12	26	sealed	6.56	167	6.97	177	4.92	125	4.92	125	17	7.71
BAT-12550	PS-12250	12	55	sealed	9.04	230	6.54	138	8.2	208	8.98	228	36	16.33
BAT-121000	PS-121000	12	100	sealed	12	305	6.6	168	8.2	208	8.98	228	68	30.84

Characteristic Discharge Curves

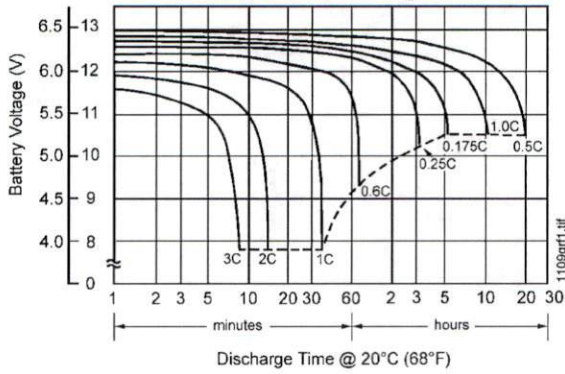

Effect of Temperature on Capacity

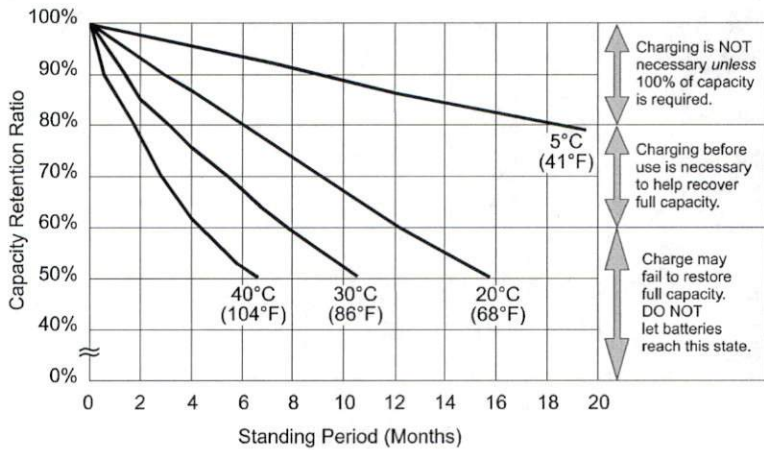
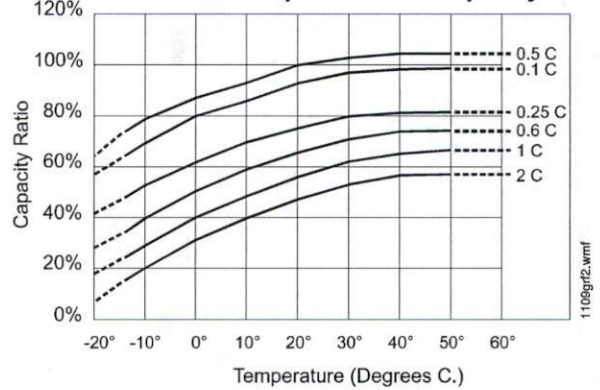

at left:
**PS-121000
Shelf-Life
and Storage**

Charging is NOT necessary unless 100% of capacity is required.
Charging before use is necessary to help recover full capacity.
Charge may fail to restore full capacity. DO NOT let batteries reach this state.

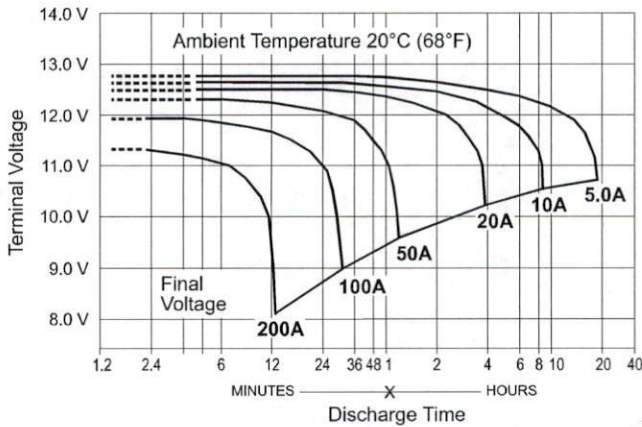

at left:
**PS-121000
Discharge
Characteristics**

Fire•Lite® Alarms is a registered trademark of Honeywell International Inc. Batteries display trademarks of the manufacturer. ©2011 by Honeywell International Inc. All rights reserved. Unauthorized use of this document is strictly prohibited.



This document is not intended to be used for installation purposes. We try to keep our product information up-to-date and accurate. We cannot cover all specific applications or anticipate all requirements. All specifications are subject to change without notice.



For more information, contact Fire•Lite Alarms. Phone: (800) 627-3473, FAX: (877) 699-4105. www.firelite.com



INTRODUCTION

The StarLink™ models **SLE-CDMA-FIRE / SLE-GSM-FIRE** and **SLECDMA-CFB / SLE3/4G-CFB** are fully supervised, sole path approved, commercial cellular fire alarm communicators supported by an extensive nationwide wireless network. Both models are compatible with most 12 or 24VDC Fire Alarm Control Panels with low standby and transmit current draw that allows them to be powered directly from the FACP. Both models are approved for use as sole path primary Fire Alarm communications or as a backup to existing telephone lines. In backup mode, the units will automatically switch the communication channel from the telephone line to the network when a telephone line trouble is detected. For Commercial installations, mount the unit to a single-, dual-, or three-gang electrical box and route the wires through the back knockout(s), or as specified by local codes. See **WI2140** for programming information.

STARLINK RADIO REPORTING PATH

The diagram below shows the transmission path of a signal from the StarLink radio to the central station.

1. **Signal from a Control Panel.**
2. **StarLink** radio receives the signal transmission (from the TIP and RING wires); sends RF signal through the GPRS network operator.
3. **Network Operator**, part of the vendor system, a section of the cellular spectrum.
4. **SLE Network Operations Center**, receives / routes data.
5. **Central Station.**

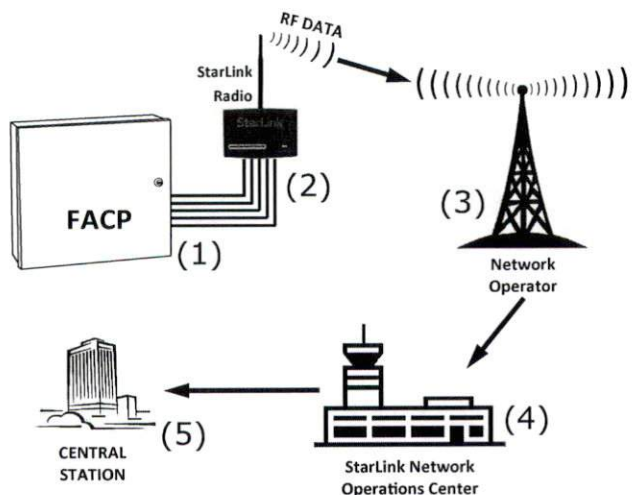

SLE-CDMA-FIRE SLE-GSM-FIRE SLECDMA-CFB SLE3/4G-CFB

Commercial Fire Series Alarm Communicators Submission Data Sheet

The SLE Series radios use proprietary data-capture technology that captures the alarm report from the control panel and transmits the alarm signals to the SLE Network Operations Center; the alarm signals are then forwarded to ANY central station via Contact ID or Sur-Gard System II via TCP/IP using standard line security. The SLE Network Operations Center reports a trouble signal in the event that the network does not receive the expected supervision signal from the wireless communicator. In addition, all models are powered directly from the control panel.

SLE-CDMA-FIRE/SLE-GSM-FIRE

Commercial / Residential Fire and Burglary CDMA / GSM radio in red plastic enclosure. Rated 12/24VDC input.



SLECDMA-CFB / SLE3/4G-CFB

Commercial / Residential Fire and Burglary CDMA / GSM radio in red metal housing. Powered directly from the control panel, rated 12/24VDC input.



FIRE ALARM COMPATABILITY

The StarLink™ models **SLE-CDMA-FIRE / SLE-GSM-FIRE** and **SLECDMA-CFB / SLE3/4G-CFB** communicators are compatible with any FACP that has a regulated 12 or 24VDC output with sufficient standby current to provide 71mA in standby mode, and 200mA in transmit mode (momentary). The FACP must be equipped with a DACT that transmits central station reports in Contact ID or 4/2 central station formats. The control panel may also trigger communication events through the use of FACP dry contacts connecting the (3) radio inputs, capable of transmitting (4) distinct alarm and trouble event reports to the central station.

ADDITIONAL COMPONENTS

In addition to the models listed above, the following accessories are available and permitted by UL:

SLE-DLCBL - Download Cable, 6 feet.

SLE-ANTEXT - Extended antenna with 15 feet of cable.

Note: Use the SLE-ANTEXT or any other External Antenna intended for the 824-894MHz and 1850-1990MHz bands.

SPECIFICATIONS

The following applies to all StarLink radio models unless otherwise stated:

Electrical Ratings (all models powered by control panel)

- Input Voltage: 12-25VDC regulated (power-limited output from Listed control panel)
- Input Current: 71mA with peak RF transmission current of 200mA

Electrical Ratings for the IN 1 Burg/Fire Input:

- Input Voltage: 9-15VDC regulated. **Note:** Models are rated 9-25VDC input
- Maximum Input Current: Up to 2mA from FACP NAC circuit

Electrical Ratings for IN 2 and IN 3:

- Maximum Loop Voltage: 15VDC. **Note:** Models are rated max 25VDC input
- Maximum Loop Current: 1.2mA
- End of Line Resistor (EOLR) Value: 10K (2 req'd)

Electrical Ratings for 3 PGM Outputs:

- Open Collector Outputs: Maximum Voltage 3V when active; 15V maximum when not active. **Note:** Models are rated max 25VDC output

- Maximum PGM Sink Current: 50mA (up to 15VDC), 25mA (15.1VDC - 25VDC)

Plastic Housings Physical

- W x H x D: $8 \times 5\frac{29}{64} \times 1\frac{1}{2}$ " (20.3 x 13.9 x 3.8cm)
- Mounting: Plastic housing includes 3 keyhole slots for mounting to single-, dual-, or three-gang electrical boxes

Metal Housings Physical

- W x H x D: $11\frac{1}{2} \times 9\frac{1}{2} \times 3\frac{1}{2}$ " (29.2 x 24.1 x 8.9cm)
- Mounting: Metal housing includes two keyhole slots for wall mounting (see WI for measurements)

Environmental

- Operating Temperature: 0°C - 49°C (32°F - 120°F)
- Humidity: Maximum 93% Non-Condensing
- Indoor / dry location use only



AGENCY LISTINGS

- UL864 9th Edition: Commercial Fire
- UL985: Household Fire Warning System Units
- UL1023: Household Burglar Alarm System Units
- UL1610: Central Station Burglar Alarm Units
- NFPA 72 National Fire Alarm Code
- CSFM: California State Fire Marshall (Fire Systems Only)
- NYCFD: NYC Fire Department (Fire Systems Only), COA #6213

CDMA models are Verizon® Network Certified
3/4G models are AT&T Accepted / Certified

NOTICE TO AUTHORITIES HAVING JURISDICTION, USERS, INSTALLERS, DEALERS, AND OTHER AFFECTED PARTIES

FIRE PROGRAMMING OPTION	PERMITTED IN UL864? (Y/N)	AVAILABLE SETTINGS	REQUIRED UL 864 SETTINGS
Unattended Remote Downloading	No	Enable / Disable	Disabled (Jumper 1 installed). Also required for Commercial / Burglary installations. Note: See Installation Instructions section "Configuration Download / Firmware Updates" for jumper instructions.
IN2 and IN3 Unsupervised	No	Supervised / Unsupervised	Supervised (Jumpers 4 and 5 installed)
Radio Path Supervision	No	200 seconds, 5 minutes, 60 minutes, 7 days	200 seconds (UL 864 / UL 1610), 5 minutes (UL 864 9th edition), 60 minutes (UL 864 10th edition), 7 days (UL 985 / UL 1023)

*For Commercial Fire installations, a UL Listed Fire Alarm regulated power supply or FACP regulated auxiliary output is required.