

Rainbow Child Care Center
95 Centennial pkwy
spout springs NC 23826



7144 Weddington Road NW, Suite 140
Charlotte, NC 28217
704-315-2600 FAX 704-315-2617
SC FA LICENSE # FAC.13537
NC FA LICENSE # 27833-SPFA/LV

MANUFACTURE'S EQUIPMENT
DATA SHEETS

FOR SUBMITTAL RECORD DRAWINGS

I have reviewed these plans and

certify that they comply with the referenced codes and standards

A handwritten signature in black ink, appearing to read "Chad Putney", is written over a horizontal line.

Signature NICET #132756 Fire Alarm Systems Level III

Chad Putney

1.26.2012

APS Printed Name

Date

ES-200X

Intelligent Addressable FACP with Communicator

 **FIRE-LITE ALARMS**
by Honeywell

Addressable Fire Alarm Control Panels

General

The **ES-200X** is the latest intelligent addressable Fire Alarm Control Panel (FACP) from Fire-Lite Alarms and is a direct replacement for the MS-9200UDLS. The ES-200X comes with a pre-installed communicator and supports up to 198 addressable devices (99 detectors and 99 modules). With an extensive list of powerful features, the ES-200X programs just like Fire-Lite's other addressable products, yet fits into applications previously served only by conventional panels.

The pre-installed IPOTS-COM is a dual technology (POTS and IP) communicator. The POTS transmits system status (alarms, troubles, AC loss, etc.) to a Central Station via the public switched telephone network. The IP communicator's internet monitoring capability sends alarm signals over the Internet saving the monthly cost of two dedicated business telephone lines. Although not required, the secondary telephone line may be retained providing backup communication over the public switched telephone line. Optional cellular reporting is available using the CELL-MOD or CELL-CAB-FL.

Remote and local programming of the control panel is possible using the FS-Tools Upload/Download utility. Programming databases can be uploaded/downloaded via the panel's USB port (and USB cable) or via an ethernet connection using the IPOTS-COM communicator. The USB port also allows for the download or upload of the entire program, history file, walk-test data, current status and system voltages by means of a USB flash drive.

The power supply and all electronics are contained on a circuit board supported on a new quick install chassis and housed in a metal cabinet. Available accessories include local and remote upload/download software, remote annunciators, and reverse polarity/city box transmitter (4XTMF).

Features

- Listed to UL Standard 864, 10th edition
- Pre-installed IPOTS-COM Ethernet IP and POTS (Plain Old Telephone Service) Central Station Communicator over AlarmNet
- Optional CELL-MOD or CELL-CAB-FL GSM Central Station Communicator over AlarmNet®
- Automated activation of the ECC-50/100 Emergency Command Center
- ECC-FFT Firefighter Telephone option
- Compatible with SWIFT® wireless devices
- Auto-programming (learn mode) reduces installation time. Reports two devices set to the same address
- Four built-in, independently programmable Style Z (Class A) or Style Y (Class B) NAC circuits
- Selectable strobe synchronization for System Sensor, Wheelock, and Gentex devices
- Notification Appliance Circuit End of Line resistor matching
- Four programmable function keys for ease of maintenance
- Two programmable relays and one fixed trouble relay
- Built-in Programmer
- Integral 80-character LCD display with backlighting
- Real-time clock/calendar with automatic daylight savings control
- History file with 1,000 event capacity
- Addressable sounder base compatibility
- Multi-criteria detector (smoke, heat, CO) with programmable response
- Control module delay timer
- Automatic detector sensitivity testing (NFPA 72 compliant)
- Automatic device type-code verification
- Point trouble identification
- Waterflow selection per module point

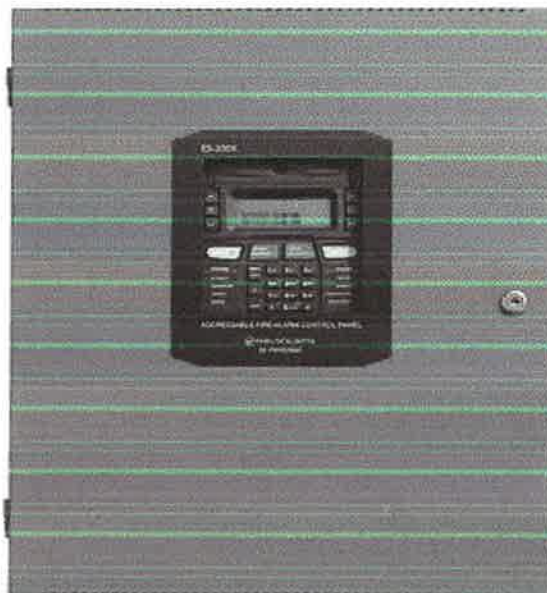

- Alarm verification selection per detector point
- Maintenance alert warns when smoke detector dust accumulation is excessive
- One-person audible or silent walk test with walk-test log and printout
- System alarm verification selection per detector point
- PAS (Positive Alarm Sequence) and Pre-signal per point (NFPA 72 compliant)
- Up to 16 ANN-BUS annunciators- 8 per each ANN-Bus
- Remote Acknowledge, Alarm Silence, Reset and Drill via addressable modules or remote annunciator
- Upload/Download of program and data via USB with optional FS-Tools Programming Utility

SLC COMMUNICATION LOOP

- Supports LiteSpeed™ and CLIP protocols
- SLC operates up to 10,000 ft. (3,000 m) in LiteSpeed mode with twisted, unshielded wire
- Single addressable SLC loop which meets NFPA Class B and Class A requirements
- 198 addressable device capacity (99 addressable detectors and 99 modules)
- Compatible with Fire-Lite's addressable devices (refer to the *SLC Wiring Manual*)

NOTIFICATION APPLIANCE CIRCUITS (NACS)

- Four independently programmable output circuits. Circuits can be configured for the following outputs:
 - Style Y (Class B)
 - Style Z (Class A)
- Silence Inhibit and Autosilence timer options
- Continuous, March Time, Temporal, or California code for main circuit board NACs with two-stage capability
- Selectable strobe synchronization per NAC
- 2.5 A special application, 250mA regulated, total power for NACs

NOTE: Maximum or total 24VDC system power shared between all NAC circuits and the ANN-BUS is 2.7 A

PROGRAMMING AND SOFTWARE

- Autoprogramming (learn mode) reduces installation time
- Custom English labels (per point) may be manually entered or selected from an internal library file
- Two programmable Form-C relay outputs
- 99 software zones
- Continuous fire protection during online programming
- Program Check automatically catches common errors not linked to any zone or input point
- **OFFLINE PROGRAMMING:** Create the entire program in your office using FS-Tools, a Windows®-based software package, and upload/download system programming locally. Offline programming requires an ethernet connection. FS-Tools is available on www.firelite.com.

User interface

LED INDICATORS

- Fire Alarm (red)
- CO Alarm (red)
- AC Power (green)
- Supervisory (yellow)
- Trouble (yellow)
- Ground fault (yellow)
- Battery fault (yellow)
- Disabled (yellow)
- Maintenance (yellow)
- Communication (yellow)
- Alarm Silenced (yellow)
- F1-F4 Programmable Function Keys (yellow)

KEYPAD

- 16 key alpha-numeric pad
- Acknowledge
- Alarm Silence
- Drill (Manual Evacuate)
- Four (4) programmable function keys
- Reset (lamp test)

PRODUCT LINE INFORMATION

ES-200X: Addressable Fire Alarm Control Panel with one SLC loop. Includes main circuit board with display, pre-installed communicator, chassis with transformer, backbox with door, plastic bag containing screws, cables, key, etc. (For ES-200XC, refer to DF-60958.)

FS-Tools: Programming software for Windows®-based PC computer. Available for download at www.firelite.com.

CELL-CAB-FL/CELL-MOD: Optional GSM communicators.

IPOTS-COM: Dual technology (POTS and IP) communicator. (replacement board)

DP-ES-R: Optional dress panel for the ES-200X.

TR-CE: Optional trim ring for semi-flush mounting.

BB-2F: Optional cabinet for one or two modules.

BB-6F: Optional cabinet for up to six modules mounted on CHS-6 chassis.

BB-26: Battery backbox, holds up to two 25 AH batteries and CHG-75.

BB-55F: Battery box, houses two 55 AH batteries

CHS-6: Chassis, mounts up to six multi-modules in a BB-6F cabinet.

CHG-75: Battery charger for lead-acid batteries with a rating of 25 to 75 AH.

CHG-120F: Remote battery charging system for lead-acid batteries with a rating of 55 to 120 AH. Requires additional BB-55F for mounting.

BAT Series: Batteries, see data sheet DF-52397.

PRN Series: UL listed compatible event printer. Uses tractor-fed paper.

OPTIONAL MODULES

4XTMF Reverse Polarity Transmitter Module: Provides a supervised output for local energy municipal box transmitter, alarm and trouble. Includes a disable switch and disable trouble LED.

PWRMOD24 Power Expander Module: Optional power module. Increases alarm power output to 6 amps.

COMPATIBLE ANNUNCIATORS

ANN-80: Remote LCD annunciator mimics the information displayed on the FACP LCD display. Recommended wire type is unshielded.

ANN-100: Remote LCD annunciator mimics the information displayed on the FACP LCD display. Recommended wire type is unshielded. For use in FM applications only.

ANN-IO: LED Driver Module provides connections to a user supplied graphic annunciator. (See DF-52430.)

ANN-LED: Annunciator Module provides three LEDs for each zone: Alarm, Trouble, and Supervisory. Ships with red enclosure. (See DF-60241.)

ANN-RLED: Provides alarm (red) indicators for up to 30 input zones or addressable points. (See DF-60241.)

ANN-RLY: Relay Module provides 10 programmable Form-C relays. Can be mounted inside the cabinet. (See DF-52431.)

ANN-S/PG: Serial/Parallel Printer Gateway module provides a connection for a serial or parallel printer. (See DF-52429.)

ADDRESSABLE DEVICES

All feature a polling LED and rotary switches for addressing.

SD365: Addressable low-profile photoelectric smoke detector. LiteSpeed only.

SD365-IV: Addressable low-profile photoelectric smoke detector. Ivory. LiteSpeed and CLIP mode.

SD365T: Addressable low-profile photoelectric smoke detector with thermal sensor. LiteSpeed only.

SD365T-IV: Addressable low-profile photoelectric smoke detector with thermal sensor. Ivory. LiteSpeed and CLIP mode.

SD365R: Remote test capable addressable photoelectric smoke detector for use with DNR(W) duct detector housing. LiteSpeed only.

SD365R-IV: Remote test capable addressable photoelectric smoke detector for use with DNR(W) duct detector housing. Ivory. LiteSpeed and CLIP mode.

H365: Low-profile 135°F fixed thermal sensor. LiteSpeed only.

H365-IV: Low-profile 135°F fixed thermal sensor. Ivory. LiteSpeed and CLIP mode.

H365R: Low-profile, intelligent, rate-of-rise thermal sensor. LiteSpeed only.

H365R-IV: Low-profile, intelligent, rate-of-rise thermal sensor. Ivory. LiteSpeed and CLIP mode.

H365HT: Low-profile intelligent 190°F/88°C fixed thermal sensor. LiteSpeed only.

H365HT-IV: Low-profile intelligent 190°F/88°C fixed thermal sensor. Ivory. LiteSpeed and CLIP mode.

Legacy Devices

CP355: Addressable low-profile ionization smoke detector.

SD355: Addressable low-profile photoelectric smoke detector.

SD355T: Addressable low-profile photoelectric smoke detector with thermal sensor.

SD355R: Remote test capable addressable photoelectric smoke detector for use with DNR(W) duct detector housing.

SD355CO: Addressable, low-profile device that provides fire, heat, and carbon monoxide (CO) detection.

H355: Fast-response, low-profile heat detector.

H355R: Fast-response, low-profile heat detector with rate-of-rise option.

H355HT: Fast-response, low-profile heat detector that activates at 190°F/88°C.

AD355: Low-profile, intelligent, "Adapt" multi-sensor detector (B350LP base included).

B200S: Programmable, addressable sounder base.

B200SR: Addressable sounder base.

BEAM355: Intelligent beam smoke detector.

BEAM355S: Intelligent beam smoke detector with integral sensitivity test.

D355PL: InnovairFlex low-flow non-relay duct-detector housing; includes SD355R.

DNR: InnovairFlex low-flow non-relay duct-detector housing. (Order SD355R/SD365R separately.)

DNRW: InnovairFlex low-flow non-relay duct-detector housing, with NEMA-4 rating. Watertight. (Order SD355R/SD365R separately.)

Addressable Modules

MMF-300: Addressable Monitor Module for one zone of normally-open dry-contact initiating devices. Mounts in standard 4.0" (10.16 cm.) box. Includes plastic cover plate and end-of-line resistor. Module may be configured for either a Style B (Class B) or Style D (Class A) IDC.

MDF-300: Dual Monitor Module. Same as MMF-300 except it provides two Style B (Class B) only IDCs.

MMF-301: Miniature version of MMF-300. Excludes LED and Style D option. Connects with wire pigtailed. May mount in device backbox.

MMF-302: Similar to MMF-300. Addressable Monitor Module for one zone of conventional two-wire detectors. Requires resettable 24 VDC power. Refer to the *Device Compatibility Document* for listed compatible devices and quantity limitation.

CMF-300: Addressable Control Module for one Style Y/Z (Class B/A) zone of supervised polarized Notification Appliances. Mounts directly to a 4.0" (10.16 cm.) electrical box. NAC option requires external 24 VDC to power notification appliances.

CRF-300: Addressable relay module containing two isolated sets of Form-C contacts, which operate as a DPDT switch. Mounts directly to a 4.0" (10.16 cm.) box, surface mount using the SMB500.

BG-12LX: Addressable manual pull station with interface module mounted inside.

I300: This module isolates the SLC loop from short circuit conditions (required for Style 6 or 7 operation).

ISO-6: Six-fault isolator module. Mount one or two modules in a BB-2F cabinet (optional). Mount up to six modules on a CHS-6 chassis in a BB-6F cabinet.

SMB500: Used to mount all modules except the MMF-301 and M301.

MMF-300-10: Ten-input monitor module. Mount one or two modules in a BB-2F cabinet (optional). Mount up to six modules on a CHS-6 chassis in a BB-6F cabinet.

MMF-302-6: Six-zone interface module. Mount one or two modules in a BB-2F cabinet (optional). Mount up to six modules on a CHS-6 chassis in a BB-6F cabinet.

CMF-300-6: Six-circuit supervised control module. Mount one or two modules in a BB-2F cabinet (optional). Mount up to six modules on a CHS-6 chassis in a BB-6F cabinet.

CRF-300-6: Six-relay control module (Form-C relays). Mount one or two modules in a BB-2F cabinet (optional). Mount up to six modules on a CHS-6 chassis in a BB-6F cabinet.

SWIFT Wireless Devices

W-GATE: LiteSpeed Wireless Gateway

W-SD355: LiteSpeed intelligent, wireless photo detector.

W-H355R: LiteSpeed intelligent wireless rate of rise (135°) heat detector.

W-SD355T: Intelligent wireless photo/heat detector.

W-H355: LiteSpeed intelligent wireless fixed-temperature (135°) heat detector.

W-MMF: LiteSpeed Intelligent wireless monitor module.

W-CRF: LiteSpeed Intelligent wireless relay module.

W-BG12LX: LiteSpeed Intelligent wireless pull station.

WAV-RL, WAV-WL, WAV-CRL, WAV-CWL: LiteSpeed Intelligent AV bases.

W-USB: Wireless USB radio/antenna dongle that plugs into the USB port of a PC running SWIFT Tools.

SWIFT Tools: Programming and diagnostic utility for the Wireless Gateway and devices. Available for download from firelite.com.

NOTE: For more information on Compatible Addressable Devices for use with the ES-200X, see the following data sheets (document numbers): SD365 Series (DF-61010), H365 Series (DF-61011), AD355 (DF-52386), BG-12LX (DF-52013), CMF-300-6 (DF-52365), CRF-300-6 (DF-52374), CMF/CRF Series (DF-52130), CP355 (DF-52383), H355 Series (DF-52385), I300 (DF-52389), ISO-6 (DF-60485), MMF-300 Series/MDF-300 (DF-52121), MMF-300-10 (DF-52347), MMF-302-6 (DF-52356), SD355/SD355T (DF-52384), and SLC Wiring Manual (51309).

NOTE: Legacy 300 Series detection devices such as the CP300/CP350, SD300(T)/SD350(T) and older modules such as the M300, M301, M302, C304, and BG-10LX are not compatible with LiteSpeed polling. If the SLC contains one of these devices, polling must be set for standard CLIP protocol. Please consult factory for further information on previous 300 Series devices.

ADDRESSABLE DEVICE ACCESSORIES

End-of-Line Resistor Assembly (R-47K and R-3.9K): The 47k ohm assembly supervises the MMF-300, MDF-300, MMF-301, and CMF-300 module circuits. The 3.9k ohm assembly supervises the MMF-302 module circuit. These resistors are included with each module.

Power Supervision Relay: Supervises the power to 4-wire smoke detectors and notification appliances.

Wiring Requirements

While shielded wire is not required, it is recommended that all SLC wiring be twisted-pair to minimize the effects of electrical interference. Refer to the panel manual for wiring details.

ECC-50/100(E)

Emergency Command Center

 **Fire-Lite Alarms**
by Honeywell

Emergency Communications

General

Fire-Lite's ECC-50/100 and ECC-50/100E are multipurpose emergency voice evacuation panels for fire applications, mass notification applications, or both. The Primary Operating Consoles (POCs) deliver 50 or 100 watts of audio power for distribution to up to eight speaker circuits (i.e. zones). The ECC-50/100(E) comes standard with a single speaker circuit and a built-in 25Vrms, 50 watt amplifier. A secondary 50 watt amplifier (ECC-50W-25/70V) can be added for single speaker circuit backup or to increase system capacity to two speaker circuits and an additional 50 watts of audio power. An optional ECC-CE6 module added to the ECC-50/100(E) will upgrade the system to a maximum of eight speaker circuit outputs. All speaker output circuits can be wired in either Style Y (Class B) or Style Z (Class A) configuration. The ECC-50/100(E) has fourteen field programmable messages (up to 60 seconds each), built-in field configurable pre- and post-announce tone generators and a fully supervised Notification Appliance Circuit (NAC) with 2.0 amps of synchronized NAC power. The ECC-50/100(E) includes three built-in Form-C relay contacts, (AC power, trouble and MNS active) a NAC follower input for triggering the on board NAC circuit and 500mA special application power. A built-in power supply with switch mode technology delivers operational power to the panel and an onboard battery charger supports charging up to 26AH batteries (ECC cabinet holds up to 18AH batteries).

For fire protection applications, the ECC-50/100(E) is an adjunct (slave) to any UL listed FACP, providing reverse polarity or contact closure; can be used as a stand-alone unit for non-fire applications. For seamless integration between fire and mass notification, the ECC-50/100(E) can be directly activated via serial communication between the ES-200X, MS-9600(UD)LS, or MS-9200UDLS. Activation of the ECC-50/100(E) via other FACPs uses the eight on board Command Input Circuits (CMDs). Two of the eight CMD circuits (CMD 1 & CMD 2) can be individually field programmed for activation by an FACP Notification Appliance Circuit reverse polarity and all eight can be activated by a contact closure. In addition, the ECC-50/100(E) can be activated from a building's Private Branch Exchange (PBX) with the integral night ring feature.

All ECC-50/100(E) programming is done by using a simple, built-in programming utility accessed from any laptop. For added flexibility, the ECC-50/100(E) supports both 25Vrms and 70.7Vrms speaker output operation. By adding a 70V transformer conversion module (ECC-XRM-70V) or an additional 70.7 volt secondary amplifier (ECC-50W-25/70V) the system supports 70.7 volt speaker devices.

The ECC-50/100(E) can expand in order to accommodate larger or more complex installations. To add more control and increase system capacity, any combination of up to eight external remote consoles (including the ECC-LOC, ECC-RPU, and ECC-RM) and up to eight distributed audio amplifiers (including the ECC-50DA(E), ECC-50BDA and ECC-125-DA(E)) can be connected on the external data bus and audio riser data bus to create a fully integrated command center. A fully loaded system supports up to 1100 watts of total audio power and up to 24 speaker circuit outputs.

TYPICAL APPLICATIONS

- Schools
- Healthcare Facilities
- Factories
- Theaters
- Military facilities
- Restaurants
- Auditoriums
- Places of Worship
- Office Buildings
- Dormitories

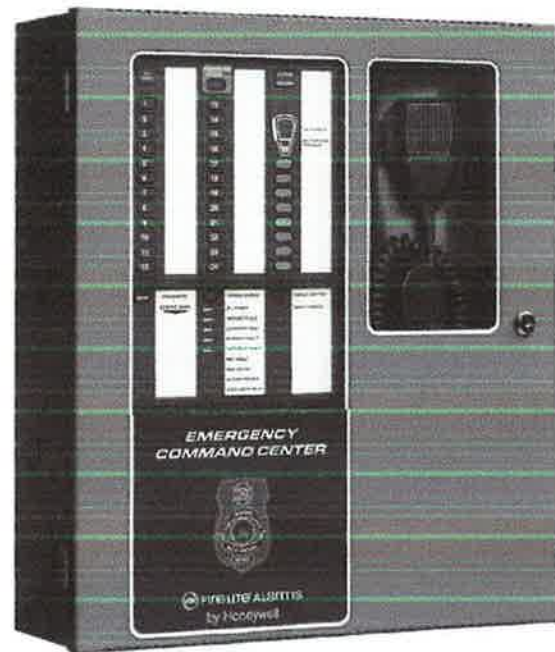

Features

- **UL Listed** to UL 2572 Communication (Control Units Mass Notification Systems) and UL 864 (emergency voice evacuation for fire)
- Modular design for system flexibility and easy expansion
- Removable terminal blocks for ease of servicing and module replacement
- 50 watts of 25V audio power (expandable to 100 watts) RMS
- 2 amp Notification Appliance Circuit (NAC) output, sync generator, or follower for System Sensor, Wheelock or Gentex protocols
- **Optional 70.7V RMS conversion transformer** available for the primary amplifier. (Note that speaker wiring continues to be supervised in standby, alarm and when background music is playing with this optional transformer installed)
- **Eight Command Input Circuits** to activate messages 1 to 8:
 - CMD1 and CMD2 are field selectable to be activated from 12 or 24 VDC Notification Appliance Circuits (reverse polarity) or contact closures
 - CMD3-CMD8 are activated by contact closures
- **Speaker Circuits**
 - Single Style Y (Class B) or Style Z (Class A) speaker Circuit
 - Two Style Y (Class B) or Style Z (Class A) speaker circuits (with optional ECC-50W-25/70V Audio Amplifier installed)
 - Eight Style Y (Class B) or Style Z (Class A) speaker circuits (with optional ECC-50W-25/70V and ECC-CE6 installed)
- 520Hz square wave tones available, which can be uploaded to the ECC-50/100 to meet NFPA Low Frequency requirements (*Refer to the Device Compatibility Document 15384 for listed compatible speakers.*)
- ECC-50/100(E) can be controlled by an FACP via the ANN/ACS (EIA-485) link. Compatible FACPs include the ES-200X, MS-9600(UD)LS, and MS-9200UDLS

- Certified for seismic applications when used with the appropriate seismic mounting kit
- Integral supervised microphone
- Microphone time-out feature which reverts back to prerecorded message if emergency page exceeds the programmed time
- 14 recorded messages
- Field-selectable message and custom message recording capability using the local microphone, a USB port, or an external audio input
- External Audio Input can be used for background music
- Up to 60 second message duration for all messages
- Integral tone generators field selectable for multiple tone types
- Powered by integral AC power supply or batteries during AC fail
- Programmable delay of immediate, 2 hours or 6 hours reporting of AC Loss
- Piezo sounder for local trouble
- 100 event history log
- Three Form-C relays:
 - AC Power Loss Relay - TB1
 - System Trouble Relay - TB2
 - MNS Active - TB3
- 500mA (0.5A) Special Application (auxiliary power) output for addressable modules when interfaced with compatible addressable FACP's and End-of-Line power supervision relays
- System Status LEDs (Refer to "Controls and Indicators" in product manual LS10001-000FL-E.)
- Integral Dress Panel
- Optional TR-CE semi-flush trim ring
- Any combination of up to eight (8) external remote consoles:
 - Optional ECC-RM Remote Microphone (includes cabinet) See DF-60760.
 - Optional ECC-RPU Remote Page Unit (includes cabinet) See DF-60761.
 - Optional ECC-LOC Local operator console (includes cabinet) See DF-60762.
- Any combination of up to eight (8) distributed audio amplifiers:
 - Optional ECC-50DA(E) distributed amplifier, 50 watts. See DF-60763.
 - Optional ECC-125DA(E) distributed amplifier, 125 watts. See DF-60763.
 - Optional ECC-50BDA distributed amplifier with backup, 100 watts. See DF-60760.

Optional Internal Expansion Modules

ECC-CE6: Circuit Expander Module provides connections for up to six Style Z (Class A) or Style Y (Class B) speaker circuits. Circuits are configured through the web-based programming utility.

ECC-50W-25V: 25V, 50 watt audio amplifier module. Adding a second speaker circuit increases the total ECC-50/100 power output to 100 watts or can also be used as a backup amplifier.

ECC-50W-70V: 70V, 50 watt audio amplifier module. Adding a second speaker circuit increases the total ECC-50/100 power output to 100 watts or can also be used as a backup amplifier.

ECC-XRM-70V: 70V Transformer Conversion Module. Converts the ECC-50/100(E) primary amplifier to a 70V output. This transformer mounts directly to the ECC-50/100(E) main control board by two metal brackets.

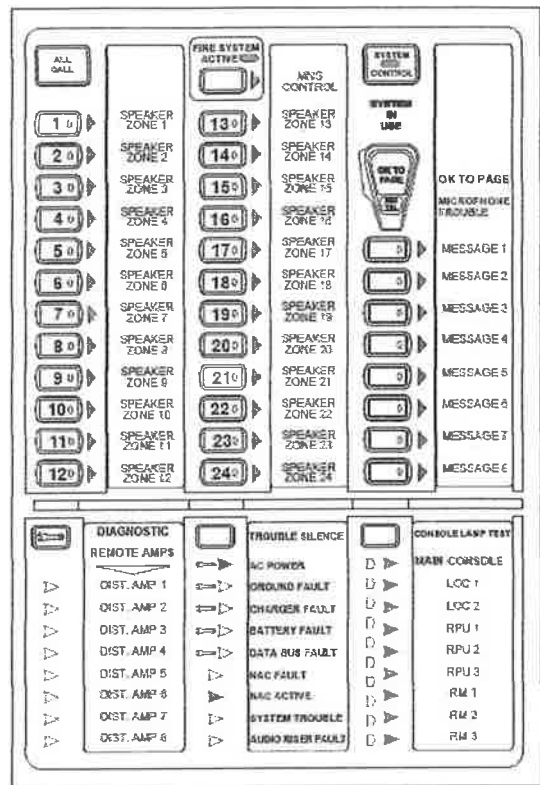

Control and Indicators

PUSH BUTTON CONTROLS

- All Call
- MNS Control
- System Control
- Speaker Select 1-24
- Message Select 1-14
- Diagnostic Select
- Trouble Silence
- Console Lamp Test

LED Status Indicators (visible with door closed)

- Fire System Active (green)
- MNS Control (green)
- System Control (green)
- System in Use (green)
- Speaker Zone 1-24 Active (green)
- Speaker Zone 1-24 Fault (yellow)
- OK to Page (green)
- Microphone Trouble (yellow)
- Message 1-8 Active (red)
- Message 1-8 Fault (yellow)
- Remote Amplifier 1-8 Fault (yellow)
- LOC/RPU/RM 1-8 Fault (yellow)
- LOC/RPU/RM 1-8 Active (green)
- Main Console Fault (yellow)
- AC Power (green)
- Ground Fault (yellow)
- Charger Fault (yellow)
- Battery Fault (yellow)
- Data Bus Fault (yellow)
- NAC Fault (yellow)
- NAC Active (green)
- System Trouble (yellow)
- Audio Riser Fault (yellow)

LED Indicators (visible with door and dress panel open)

- Speaker Volume Control Fault (yellow)
- Option Card Fault (yellow)
- Amplifier Over Current Fault (yellow)

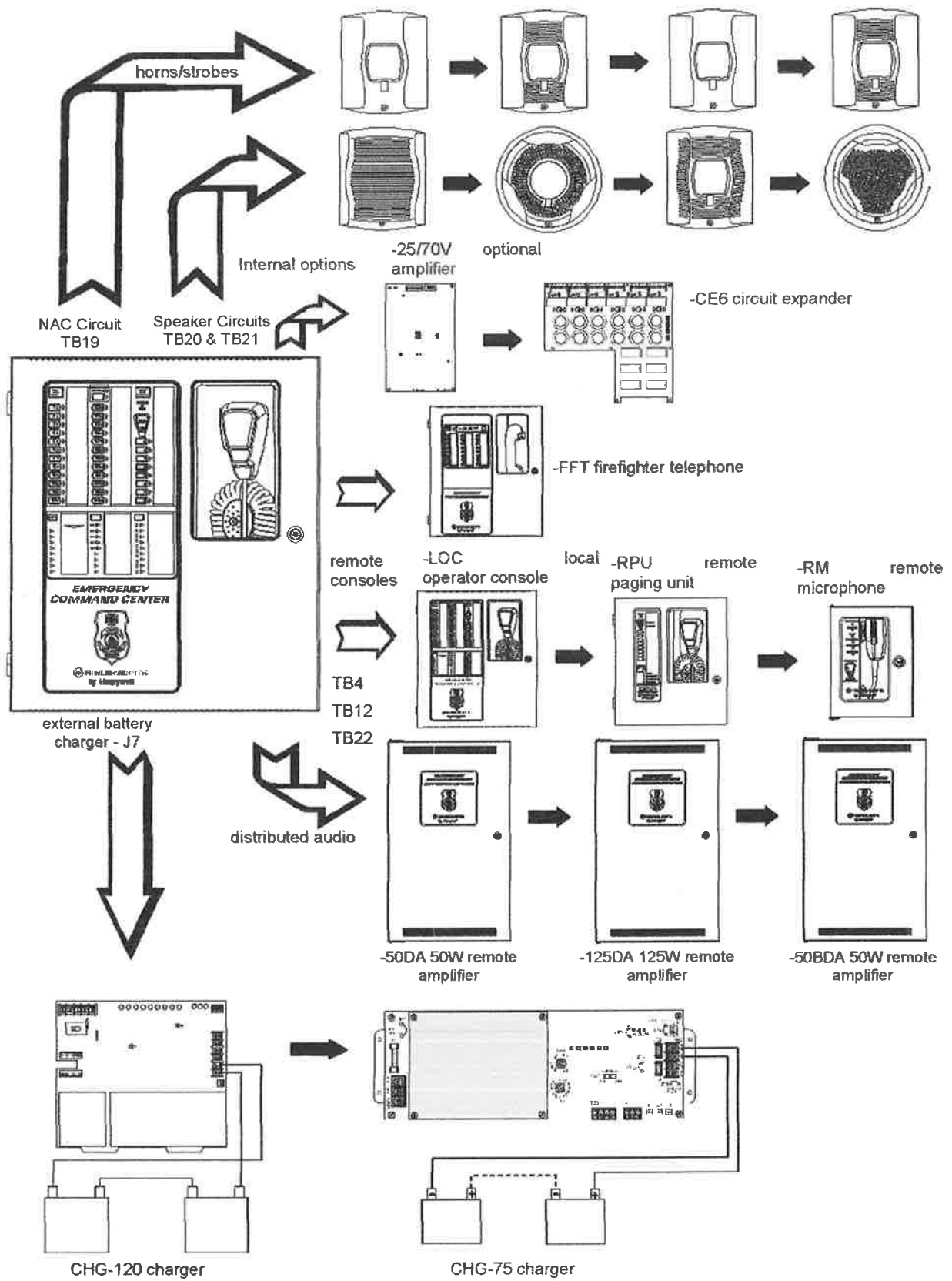

Product Line Information

ECC-50/100: (Primary Operating Console) 50 Watt, 25VRMS single speaker zone emergency voice evacuation system, integral microphone, built in tone generator and 14 recordable messages.

ECC-50/100E: Export version (Primary Operating Console) 50 Watt, 25VRMS single speaker zone emergency voice evacuation system, integral microphone, built in tone generator and 14 recordable messages. (240 VAC, 50Hz).

ECC-CE6: Speaker Circuit/Zone Expander Module.

ECC-50W-25V: 25V, 50 watt audio amplifier module. Adding a second speaker circuit increases the total ECC-50/100 power output to 100 watts or can also be used as a backup amplifier.

ECC-50W-70V: 70V, 50 watt audio amplifier module. Adding a second speaker circuit increases the total ECC-50/100 power output to 100 watts or can also be used as a backup amplifier.

ECC-XRM-70V: 70V Transformer Conversion Module. Converts the ECC-50/100(E) primary amplifier to a 70V output. This transformer mounts directly to the ECC-50/100(E) main control board by two metal brackets.

ECC-LOC: Local Operator Console (Complete user interface). Please refer to the data sheet DF-60762 for more information.

ECC-RPU: Remote Page Unit Hand held microphone, 14 message buttons. Please refer to the data sheet DF-60761 for more information.

ECC-RM: Remote Microphone only. Please refer to the data sheet DF-60760 for more information.

ECC-50DA: Distributed (Remote) Audio Amplifier, 50 watts. Please refer to the data sheet DF-60763 for more information.

ECC-50DAE: Export version. Distributed (Remote) Audio Amplifier, 50 watts. (240 VAC, 50Hz). Please refer to the data sheet DF-60763 for more information.

ECC-125DA: Distributed (Remote) Audio Amplifier, 125 watts. Please refer to the data sheet DF-60763 for more information.

ECC-125DAE: Export version. Distributed (Remote) Audio Amplifier, 125 watts. (240 VAC, 50Hz). Please refer to the data sheet DF-60763 for more information.

ECC-50BDA: Distributed (Remote) Audio Amplifier with back up, 50 watts/100 watts at 25Vrms or 70Vrms. Please refer to the data sheet DF-60763 for more information.

ECC-50WBU: Expander card for ECC-50BDA remote amplifier for 100 watt primary / 50 watt back up operation. Please refer to the data sheet DF-60763 for more information.

ECC-CE4: Distributed Audio Speaker Circuit/Zone expander module.

ECC-FFT: Fire Fighter Telephone System. Please refer to the data sheet DF-60765 for more information.

ECC-RTZM: Remote Telephone Zone Module. Allows for secure access to the ECC via cell phone or remote telephone means; not UL listed. Please refer to the data sheet DF-60785 for more information.

SEISKIT-COMMENC: Seismic kit for the ECC-50/100. Includes battery bracket for two 12 AH or 18 AH batteries.

FPJ-F: Remote Phone Jack.

FHS-F: Fire Fighters Remote Handset.

FHSC-RF: Fire Fighters Handset Cabinet Recessed.

FHSC-SF: Fire Fighters Handset Cabinet Surface Mount.

MMF-301: Addressable Mini-Monitor Module.

I300: SLC Line Isolation Module.

TR-CE: Optional Trim Ring.

THUMBLTCH: Optional Thumb Latch. (Non UL-Listed).

CHG-75: 25 to 75 ampere-hours (AH) External Battery Charger.

CHG-120F: 25-120 ampere-hours (AH) External Battery Charger.

ECC-MICROPHONE: Replacement Microphone only.

BAT-1270: Battery, 12 volt, 7.0 AH (Two required).

BAT-12120: Battery, 12 volt, 12.0 AH (Two required).

BAT-12180: Battery, 12 volt, 18.0 AH (Two required).

Wiring Requirements

See product manual, part number LS10001-000FL-E for detailed wiring requirements.

Total System Capacity: (ECC-50/100(E) only)

- Total Built-in Audio Power: 50 Watts.
- Total Expandable Audio Power: 100 Watts.
- Total Built-in Speaker Circuits: 2.
- Total Expandable Speaker Circuits: 8.
- Audio Message Max Time Duration: 60 seconds.
- External Audio Input: 1.

Total System Capacity: (Fully Loaded System)

- Total Distributed Audio Power: 1100 Watts.
- Total Speaker Circuits Per System: 24.
- Total Remote Consoles Supported: 8.
- Total Distributed Audio Amplifiers Supported: 8.

Electrical Specifications

PRIMARY (AC) POWER (TB15)

ECC-50/100: 120 VAC, 60 Hz, 3.5 amps.

ECC-50/100E: 240 VAC, 50 Hz, 2.0 amps.

Wire size: minimum #14 AWG (2.00mm²) with 600 V insulation.

SECONDARY POWER (BATTERY) CHARGING CIRCUIT (JT)

- Supports lead-acid batteries only.
- Float charge voltage at 27.3V
- Maximum charge current: 1.0 Amp
- Maximum battery charge capability: 2.8 Amps, 26AH (ECC cabinet holds max. 18AH battery).
- Minimum Battery size: 12 Amp Hour.

AC LOSS RELAY CONTACT RATING (TB3)

- 2.0 amps @ 30 VDC (resistive), 0.5 amps @ 30 VAC (resistive).

FORM C - TROUBLE RELAY CONTACT RATING (TB2)

- 2.0 amps @ 30 VDC (resistive), 0.5 amp @ 30 VAC (resistive).

MNS ACTIVE RELAY CONTACT RATING (TB1)

- 2.0 amps @ 30 VDC (resistive), 0.5 amps @ 30 VAC (resistive).

NOTIFICATION APPLIANCE CIRCUIT (NAC) OUTPUT RATING (TB19)

- One (1) Style Y (Class B) or Style Z (Class A) circuit.
- Power-limited circuitry, (Class 2) supervised.
- Nominal operating voltage: 24 VDC.
- Maximum signaling current for special application power: 2.0A.
- Maximum signaling current for regulated power: 200mA.
- Maximum wiring impedance: 1Ω.
- Current limit: fuse-less, electronic, power-limited.

- End-Of-Line Resistor: 4.7 K Ω , ½ watt, (P/N 71252) required for Style Y (Class B) operation.

Refer to the Device Compatibility Document 15384 for listed compatible devices.

NAC FOLLOWER OUTPUT REMOTE SYNC (TB18)

- Connections for FACP NAC synchronization trigger signal.
- Output terminals: pass-through to other system components.
- Trigger input voltage: 9 to 32 VDC, 24 VDC rated.
- Input current draw in Alarm condition: 10 mA at rated voltage.

SPECIAL APPLICATION POWER (AUX. POWER) (TB17)

- 500 mA @ 24 VDC.
- Used for powering addressable modules and associated End-of-Line power supervision relays.

Power-limited circuitry. Refer to the Device Compatibility Document 15384 for a list of compatible devices.

SPEAKER VOLUME CONTROL OVERRIDE (TB23)

- Style Y (Class B) or Style Z (Class A) circuit.
- Special application power.
- Power-limited circuitry, supervised.
- Nominal operating voltage: 24 VDC.
- Maximum signaling current: 0.25 amps.
- Current limit: fuse-less, electronic, power-limited.
- End-Of-Line Resistor: 4.7 K Ω , ½ watt, (P/N 71252) required for Style Y (Class B) operation.

SPEAKER CIRCUITS

- Primary Speaker Circuit (TB20)
- Secondary Speaker Circuit (TB21) (with optional amplifier only).
 - Circuit can be wired Style Y (Class B) or Style Z (Class A).
 - Power-limited circuitry.
 - Normal Operating Voltage: 25 VRMS @ 2 amps max and maximum Load Impedance of 12.5 Ω (70.7 VRMS @ 700 mA max. with maximum load Impedance of 100 Ω operation possible by plugging optional ECC-XRM-70V conversion transformer into J12 of the main control board).
 - Output Power: 50 watts (10 watts when background music is employed).
 - Frequency Range: 400Hz - 4,000Hz.
 - Maximum total capacitance for each speaker circuit: 250 μ F.
 - End-of-Line Resistor required for Style Y circuit: 15 K Ω , 1 watt (P/N: ELR-15K).

COMMAND INPUT CIRCUITS (ALARM POLARITIES SHOWN)

CMD1 - TB4 Terminals 3(+) & 4(-) are input terminals and Terminals 1(-) and 2(+) are output terminals which provide feed through of the NAC circuits to NAC devices down stream.

CMD2 - TB5 Terminals 3(+) & 4(-) are input terminals and Terminals 1(-) and 2(+) are output terminals which provide feed through of the NAC circuits to NAC devices downstream.

CMD3 - TB6 Terminals 1(+) & 2(-) are input terminals for contact closure only.

CMD4 - TB6 Terminals 3(+) & 4(-) are input terminals for contact closure only.

CMD5 - TB7 Terminals 1(+) & 2(-) are input terminals for contact closure only.

CMD6 - TB7 Terminals 3(+) & 4(-) are input terminals for contact closure only.

CMD7 - TB8 Terminals 1(+) & 2(-) are input terminals for contact closure only.

CMD8 - TB8 Terminals 3(+) & 4(-) are input terminals for contact closure only.

- Power-limited and supervised circuitry.
- Normal Operating Voltage Range: 10.5 VDC - 29 VDC; (Maximum Voltage: 29 VDC).
- NAC Reverse Polarity Current (requires End-of-Line Resistor from NAC): 1.6 mA maximum.
- Contact Closure Operation Current (requires 4.7K Ω , ½ watt End-of-Line Resistor P/N 27072): 6.6 mA maximum.
- Maximum Wiring Impedance CMD1 - CMD8 (Contact Closure Operation): 200 Ω .

NOTE: When the system is programmed for Mass Notification, CMD1 and CMD2 will be programmed for Reverse Polarity only. See manual P/N LS10001-000FL-E for more details.

MAXIMUM INPUT IMPEDANCE:

- CMD1 & CMD2 (Reverse Polarity Operation): 20K Ω .
- CMD1 - CMD8 (Contact Closure Operation): 4.75K Ω .

NIGHT RING INPUT - TB16, TERMINALS 1 (+) & 2 (-)

- Contact closure input.
- Isolated, non-supervised.
- Operation current: 3.8 mA, maximum.
- Maximum wiring impedance: 30K Ω .
- Minimum isolation withstand voltage: 1500 VRMS.

EXTERNAL OPERATOR INTERFACE POWER OUTPUT (TB24)

- Non-resettable power for external operator interface components.
- Power-limited circuitry, non-supervised.
- Nominal operating voltage: 24 VDC.
- Maximum output current: 0.80 amps.
- Current limit: fuse-less, electronic, power-limited circuit.

EXTERNAL DATA BUS (EIA-485) (TB12)

- Data connections for external operator interface components.
- Redundant transceiver circuitry for Class A operability.
- Power-limited circuitry, supervised.
- Maximum wiring impedance: 13.2 Ω

FACP DATA BUS (EIA-485) (TB13)

- Dedicated connection to FACP serial bus.
- Output terminals: pass-through to other system components.
- Isolated, supervised.
- Minimum isolation withstand voltage: 1500 VRMS.
- Maximum wiring impedance: 40 Ω (ANN-BUS), 26 Ω (ACS-BUS).
- External Audio Riser (TB22).
- Style Y (Class B) or Style Z (Class A) audio connections to external operator interface components.
- Power-limited circuitry, supervised.
- Audio signal level: 3.85 V, maximum.
- Frequency range: 400 Hz - 4 KHz RMS.
- Frequency range (ECC-50/125DA): 800Hz - 2KHz RMS.

Electrical Specifications Display Board

EXTERNAL AUDIO INPUT (TB5)

- Input Impedance: 8.5K Ω nominal @1KHz
- Input Voltage: 700 mV rms maximum
- Input Current: 0.1 mA maximum @ 700 mV

NOTE: Some laptops/personal computers only provide an audio output for headphones. It may be necessary to adjust the headphone output level for proper recording of voice messages.

ECC-CE6 Circuit Expander Module Specifications

- Power-limited circuitry.
- Up to six (6) circuits on the ECC-CE6 can be wired as Style Y (Class B) or Style Z (Class A).
- Normal Operating Voltage for Speaker Circuits: 25 VRMS @ 2.0 amps max. (Maximum Load Impedance of 12.5 Ω).
- 70.0 VRMS @ 700 mA max. with maximum Load Impedance of 100 Ω operation possible for the primary circuit by plugging in an optional ECC-XRM-70V conversion transformer into J12 of the main control board. The same operation is possible for the optional 50W amplifier by selecting the ECC-50W-70V model.
- Speaker circuit wiring is supervised during standby, background music, and alarm.
- Output Power: 50 watts total; Frequency Range: 400Hz - 4,000Hz.
- Maximum total capacitance: 250 μ F. (Note that the total capacitance for the speaker outputs must not exceed the maximum of 250 μ F.)
- End-of-Line Resistor required for Style Y (Class B) speaker circuit: 15 K Ω , 1 watt (P/N: ELR-15K) TB13 on the main control board; ACS/ANN (EIA-485) electrically isolated link to FACP provides programmed speaker control.

Cabinet Specifications

- Backbox: 19.0"(48.26 cm) high x 16.65"(42.29 cm) wide x 5.20"(13.23 cm) deep.
- Door: 19.26" (48.92 cm) high x 16.82"(42.73 cm) wide x 0.12"(0.30 cm) deep.
- Trim Ring (TR-CE): 22.00" (55.88 cm) high x 19.65" (49.91 cm) wide.

Shipping Specifications

Base Unit Weight: 27.85 lbs (12.63 kg).

Temperature and Humidity ranges

This system meets NFPA requirements for operation at 0 – 49°C/32 – 120°F and at a relative humidity 93% \pm 2% RH (noncondensing) at 32°C \pm 2°C (90°F \pm 3°F). However, the useful life of the system's standby batteries and the electronic components may be adversely affected by extreme temperature ranges and humidity. Therefore, it is recommended that this system and its peripherals be installed in an environment with a normal room temperature of 15 – 27°C/60 – 80°F.

Agency Listings and Approvals

The listings and approvals below apply to the basic ECC-50/100(E) control panel. In some cases, certain modules may not be listed by certain approval agencies or listing may be in process. Consult factory for latest listing status.

- UL/ULC Listed: S2424
- CSFM: 6911-0075:0226
- NYC Fire Dept. Certificate of Approval: #6152
- FM Approved

Standards and Codes

The ECC-50/100(E) complies with the following UL Standards, NFPA 72, International Building Codes, and California Building Codes.

- UL 864
- UL 2572
- UFC 4-021-01
- IBC 2012, IBC 2009, IBC 2006, IBC 2003, IBC 2000 (Seismic)
- CBC 2007 (Seismic)

Fire-Lite® Alarms is a registered trademark of Honeywell International Inc. ©2018 by Honeywell International Inc. All rights reserved. Unauthorized use of this document is strictly prohibited.



This document is not intended to be used for installation purposes.
We try to keep our product information up-to-date and accurate.
We cannot cover all specific applications or anticipate all requirements.
All specifications are subject to change without notice.



For more information, contact Fire-Lite Alarms. Phone: (800) 627-3473, FAX: (877) 699-4105.
www.firelite.com

Country of Origin: USA

ANN-80

80-Character Serial LCD Annunciator

 **Fire-Lite Alarms**
by Honeywell

Annunciators

General

The ANN-80 annunciator is a compact, backlit, 80-character LCD fire annunciator that mimics the Fire Alarm Control Panel (FACP) display. It provides system status indicators for AC Power, Alarm, Trouble, Supervisory, and Alarm Silenced conditions. The ANN-80 and the FACP communicate over a two-wire serial interface employing the ANN-Bus communication format. Connected devices are powered, via two additional wires, by either the host FACP or a remote UL-listed, filtered power supply. The ANN-80 is red; for white, order ANN-80-W.

The ANN-80 displays English-language text of system point information including device type, zone, independent point alarm, trouble or supervisory status, as well as any custom alpha labels programmed into the control panel. It includes control switches for remote control of critical system functions. (A keyswitch prevents unauthorized operation of the control switches.)

Up to eight ANN-80s may be connected to the ANN-Bus of each FACP. No programming is required, which saves time during system commissioning.

Features

- Listed to UL Standard 864, 9th Edition
- Backlit 80-character LCD display (20 characters x 4 lines)
- Mimics all display information from the host panel
- Control switches for System Acknowledge, Signal Silence, Drill, and Reset
- Control switches can be independently enabled or disabled at the FACP
- Keyswitch enables/disables control switches and mechanically locks annunciator enclosure
- Keyswitch can be enabled or disabled at the FACP
- Enclosure supervised for tamper
- System status LEDs for AC Power, Alarm, Trouble, Supervisory, and Alarm Silence
- Local sounder can be enabled or disabled at the FACP
- ANN-80 connects to the ANN-Bus terminal on the FACP and requires minimal panel programming
- Displays device type identifiers, individual point alarm, trouble, supervisory, zone, and custom alpha labels
- Time-and date display field
- Surface mount directly to wall or to single, double, or 4" square electrical box
- Semi-flush mount to single, double, or 4" square electrical box. Use ANN-SB80KIT for angled view mounting
- Can be remotely located up to 6,000 feet (1,800 m) from the panel
- Backlight turns off during AC loss to conserve battery power but will turn back on if an alarm condition occurs
- May be powered by 24 VDC from the host FACP or by remote power supply (requires 24 VDC)
- Up to eight ANN-80s can be connected on the ANN-Bus

Controls and Indicators

- AC Power
- Alarm
- Trouble



- Supervisory
- Alarm Silenced

Specifications

- **Operating voltage range:** 18 VDC to 28 VDC
- **Current consumption @ 24 VDC nominal** (filtered and non-resettable): 40 mA maximum
- **Ambient temperature:** 32°F to 120°F (0°C to 49°C)
- **Relative humidity:** 93% ± 2% RH (non-condensing) at 32°C ± 2°C (90°F ± 3°F)
- 5.375" (13.65 cm.) high x 6.875" (17.46 cm.) wide x 1.375" (3.49 cm.) deep
- For use indoors in a dry location
- All connections are power-limited and supervised

The ANN-Bus

POWERING THE DEVICES ON THE ANN-BUS FROM AUXILIARY POWER SUPPLY

The ANN-Bus can be powered by an auxiliary power supply when the maximum number of ANN-Bus devices exceeds the ANN-Bus power requirements. See the FACP manual for more information.

ANN-BUS DEVICE ADDRESSING

Each ANN-Bus device requires a unique address (ID Number) in order to communicate with the FACP. A maximum of 8 devices can be connected to the FACP ANN-Bus communication circuit. See the FACP manual for more information.

WIRE REQUIREMENTS: COMMUNICATIONS CIRCUIT

The ANN-80 connects to the FACP ANN-Bus communications circuit. To determine the type of wire and the maximum wiring distance that can be used with FACP ANN-Bus accessory modules, it is necessary to calculate the total worst case current draw for all modules on a single 4-conductor bus. The total worst case current draw is calculated by adding the individual worst case currents for each module.

NOTE: For total worst case current draw on a single ANN-Bus refer to appropriate FACP manual.

WIRE REQUIREMENTS: POWER CIRCUIT

- 14 to 18 AWG (0.75 - 2.08 mm²) wire for 24 VDC power circuit is acceptable. Power wire distance limitation is set by 1.2 volt maximum line drop from source to end of circuit.
- All connections are power-limited and supervised.
- A maximum of eight ANN-80 modules may be connected to this circuit.

Ordering Options

ANN-80: Red 80 character LCD Annunciator.

ANN-80-W: White, 80 character LCD Annunciator.

ANN-SB80KIT-R: Red surface mount backbox with angled wedge.

ANN-SB80KIT-W: White surface mount backbox with angled wedge.

Agency Listings and Approvals

The listings and approvals below apply to the ANN-80. In some cases, certain modules may not be listed by certain approval agencies, or listing may be in process. Consult factory for latest listing status.

- **UL:** S2424
- **FM approved**
- **CSFM:** 7120-0075:0211
- **MEA:** 442-06-E

Fire-Lite® Alarms is a registered trademark of Honeywell International Inc.
©2018 by Honeywell International Inc. All rights reserved. Unauthorized use of this document is strictly prohibited.



This document is not intended to be used for installation purposes.
We try to keep our product information up-to-date and accurate.
We cannot cover all specific applications or anticipate all requirements.
All specifications are subject to change without notice.

For more information, contact Fire-Lite Alarms. Phone: (800) 627-3473, FAX: (877) 699-4105.
www.firelite.com



Country of Origin: USA



Indoor Selectable-Output Horns, Strobes, and Horn Strobes for Wall Applications

System Sensor L-Series audible visible notification products are rich with features guaranteed to cut installation times and maximize profits with lower current draw and modern aesthetics.

Features

- Updated Modern Aesthetics
- Small profile devices for Horns and Horn Strobes
- Plug-in design with minimal intrusion into the back box
- Tamper-resistant construction
- Automatic selection of 12- or 24-volt operation at 15 and 30 candela
- Field-selectable candela settings on wall units: 15, 30, 75, 95, 110, 135, and 185
- Horn rated at 88+ dBA at 16 volts
- Rotary switch for horn tone and two volume selections
- Mounting plate for all standard and all compact wall units
- Mounting plate shorting spring checks wiring continuity before device installation
- Electrically compatible with legacy SpectrAlert and SpectrAlert Advance devices
- Compatible with MDL3 sync module
- Strobes and Horn Strobes listed for wall mounting only
- Horns listed for wall or ceiling use

Agency Listings



FM approved except
for A-EPT models:
3057323, 3057072



7125-1853 0524
7126-1853 0503

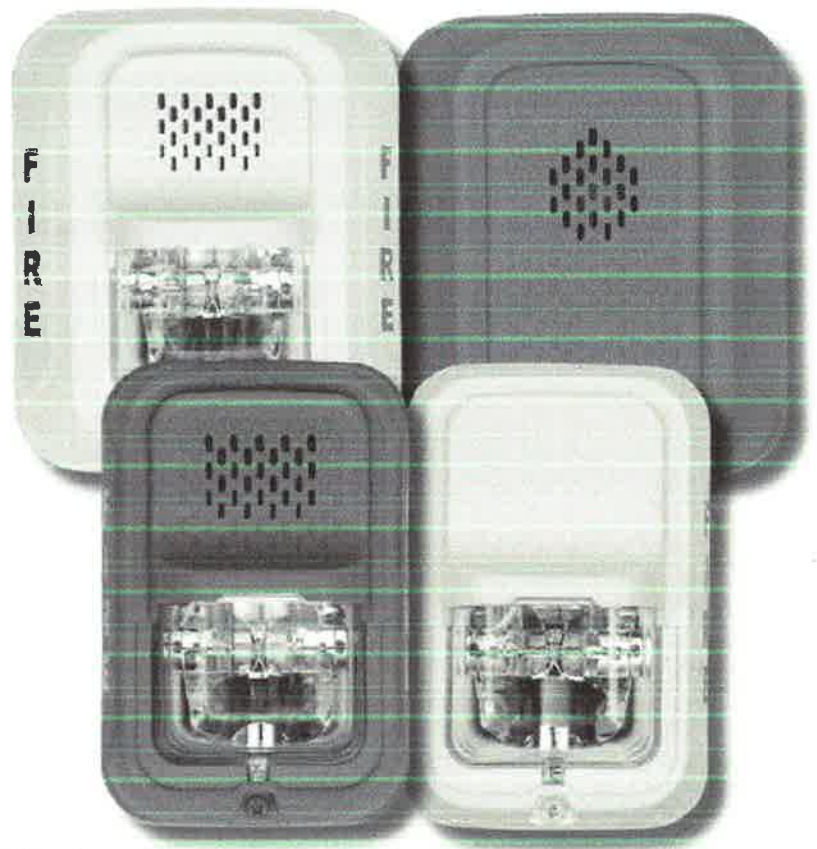

The System Sensor L-Series offers the most versatile and easy-to-use line of horns, strobes, and horn strobes in the industry with lower current draws and modern aesthetics. With white and red plastic housings, standard and compact devices, and plain, FIRE, and FUEGO-printed devices, System Sensor L-Series can meet virtually any application requirement.

The L-Series line of wall-mount horns, strobes, and horn strobes include a variety of features that increase their application versatility while simplifying installation. All devices feature plug-in designs with minimal intrusion into the back box, making installations fast and foolproof while virtually eliminating costly and time-consuming ground faults.

To further simplify installation and protect devices from construction damage, the L-Series utilizes a universal mounting plate for all models with an onboard shorting spring, so installers can test wiring continuity before the device is installed.

Installers can also easily adapt devices to a suit a wide range of application requirements using field-selectable candela settings, automatic selection of 12- or 24-volt operation, and a rotary switch for horn tones with two volume selections.

L-Series Specifications

Architect/Engineer Specifications

General

L-Series standard horns, strobes, and horn strobes shall mount to a standard 2 x 4 x 1⁷/₈-inch back box, 4 x 4 x 1⁷/₈-inch back box, 4-inch octagon back box, or double-gang back box. L-Series compact products shall mount to a single-gang 2 x 4 x 1⁷/₈-inch back box. A universal mounting plate shall be used for mounting ceiling and wall products for all standard models and a separate universal mounting plate shall be used for mounting wall compact models. The notification appliance circuit wiring shall terminate at the universal mounting plate. Also, L-Series products, when used with the Sync•Circuit™ Module accessory, shall be powered from a non-coded notification appliance circuit output and shall operate on a nominal 12 or 24 volts. When used with the Sync•Circuit Module, 12-volt-rated notification appliance circuit outputs shall operate between 8.5 and 17.5 volts; 24-volt-rated notification appliance circuit outputs shall operate between 16.5 and 33 volts. Indoor L-Series products shall operate between 32 and 120 degrees Fahrenheit from a regulated DC or full-wave rectified unfiltered power supply. Strobes and horn strobes shall have field-selectable candela settings including 15, 30, 75, 95, 110, 135, and 185.

Strobe

The strobe shall be a System Sensor L-Series Model SRL listed to UL 1971 and shall be approved for fire protective service. The strobe shall be wired as a primary-signaling notification appliance and comply with the Americans with Disabilities Act requirements for visible signaling appliances, flashing at 1 Hz over the strobe's entire operating voltage range. The strobe light shall consist of a xenon flash tube and associated lens/reflector system.

Horn Strobe Combination

The horn strobe shall be a System Sensor L-Series Model N/A listed to UL 1971 and UL 464 and shall be approved for fire protective service. The horn strobe shall be wired as a primary-signaling notification appliance and comply with the Americans with Disabilities Act requirements for visible signaling appliances, flashing at 1 Hz over the strobe's entire operating voltage range. The strobe light shall consist of a xenon flash tube and associated lens/reflector system. The horn shall have two audibility options and an option to switch between a temporal three pattern and a non-temporal (continuous) pattern. These options are set by a multiple position switch. The horn on horn strobe models shall operate on a coded or non-coded power supply.

Synchronization Module

The module shall be a System Sensor Sync•Circuit model MDL3 listed to UL 464 and shall be approved for fire protective service. The module shall synchronize Strobes at 1 Hz and horns at temporal three. Also, while operating the strobes, the module shall silence the horns on horn strobe models over a single pair of wires. The module shall mount to a 4¹¹/₁₆ x 4¹¹/₁₆ x 2¹/₈-inch back box. The module shall also control two Style Y (class B) circuits or one Style Z (class A) circuit. The module shall synchronize multiple zones. Daisy chaining two or more synchronization modules together will synchronize all the zones they control. The module shall not operate on a coded power supply.

Physical/Electrical Specifications

Standard Operating Temperature	32°F to 120°F (0°C to 49°C)
Humidity Range	10 to 93% non-condensing
Strobe Flash Rate	1 flash per second
Nominal Voltage	Regulated 12 DC or regulated 24 DC/FWR ¹
Operating Voltage Range ²	8 to 17.5 V (12 V nominal) or 16 to 33 V (24 V nominal)
Operating Voltage Range MDL3 Sync Module	8.5 to 17.5 V (12 V nominal) or 16.5 to 33 V (24 V nominal)
Input Terminal Wire Gauge	12 to 18 AWG
Wall-Mount Dimensions (including lens)	5.6" L x 4.7" W x 1.91" D (143 mm L x 119 mm W x 49 mm D)
Compact Wall-Mount Dimensions (including lens)	5.26" L x 3.46" W x 1.91" D (133 mm L x 88 mm W x 49 mm D)
Horn Dimensions	5.6" L x 4.7" W x 1.25" D (143 mm L x 119 mm W x 32 mm D)
Compact Horn Dimensions	5.25" L x 3.45" W x 1.25" D (133 mm L x 88 mm W x 32 mm D)

1. Full Wave Rectified (FWR) voltage is a non-regulated, time-varying power source that is used on some power supply and panel outputs.

2. Strobe products will operate at 12 V nominal only for 15 cd and 30 cd.

UL Current Draw Data

UL Max. Strobe Current Draw (mA RMS)				
Candela Range	Candela	8-17.5 Volts		
		DC	DC	FWR
Candela Range	15	88	43	60
	30	143	63	83
	75	N/A	107	136
	95	N/A	121	155
	110	N/A	148	179
	135	N/A	172	209
	185	N/A	222	257

UL Max. Horn Current Draw (mA RMS)				
Sound Pattern	dB	8-17.5 Volts		
		DC	DC	FWR
Temporal	High	39	44	54
Temporal	Low	28	32	54
Non-Temporal	High	43	47	54
Non-Temporal	Low	29	32	54
3.1 KHz Temporal	High	39	41	54
3.1 KHz Temporal	Low	29	32	54
3.1 KHz Non-Temporal	High	42	43	54
3.1 KHz Non-Temporal	Low	28	29	54
Coded	High	43	47	54
3.1 KHz Coded	High	42	43	54

UL Max. Current Draw (mA RMS), Wall Horn Strobe, Candela Range (15-185 cd)									
DC Input	8-17.5 Volts			16-33 Volts					
	15cd	30cd	15cd	30cd	75cd	95cd	110cd	135cd	185cd
Temporal High	98	158	54	74	121	142	162	196	245
Temporal Low	93	154	44	65	111	133	157	184	235
Non-Temporal High	106	166	73	94	139	160	182	211	262
Non-Temporal Low	93	156	51	71	119	139	162	190	239
3.1K Temporal High	93	156	53	73	119	140	164	190	242
3.1K Temporal Low	91	154	45	66	112	133	160	185	235
3.1K Non-Temporal High	99	162	69	90	135	157	175	208	261
3.1K Non-Temporal Low	93	156	52	72	119	138	162	192	242
FWR Input	16-33 Volts								
	15cd	30cd	75cd	95cd	110cd	135cd	185cd		
Temporal High	83	107	156	177	198	234	287		
Temporal Low	68	91	145	165	185	223	271		
Non-Temporal High	111	135	185	207	230	264	316		
Non-Temporal Low	79	104	157	175	197	235	283		
3.1K Temporal High	81	105	155	177	196	234	284		
3.1K Temporal Low	68	90	145	166	186	222	276		
3.1K Non-Temporal High	104	131	177	204	230	264	326		
3.1K Non-Temporal Low	77	102	156	177	199	234	291		

Horn Tones and Sound Output Data

Horn and Horn Strobe Output (dBA)					
Switch Position	Sound Pattern	dB	8-17.5 Volts		
			DC	DC	FWR
1	Temporal	High	84	89	89
2	Temporal	Low	75	83	83
3	Non-Temporal	High	85	90	90
4	Non-Temporal	Low	76	84	84
5	3.1 KHz Temporal	High	83	88	88
6	3.1 KHz Temporal	Low	76	82	82
7	3.1 KHz Non-Temporal	High	84	89	89
8	3.1 KHz Non-Temporal	Low	77	83	83
9*	Coded	High	85	90	90
10*	3.1 KHz Coded	High	84	89	89

* Settings 9 and 10 are not available on 2-wire horn strobes. Temporal coding must be provided by the NAC. If the NAC voltage is held constant, the horn output remains constantly on.

L-Series Dimensions

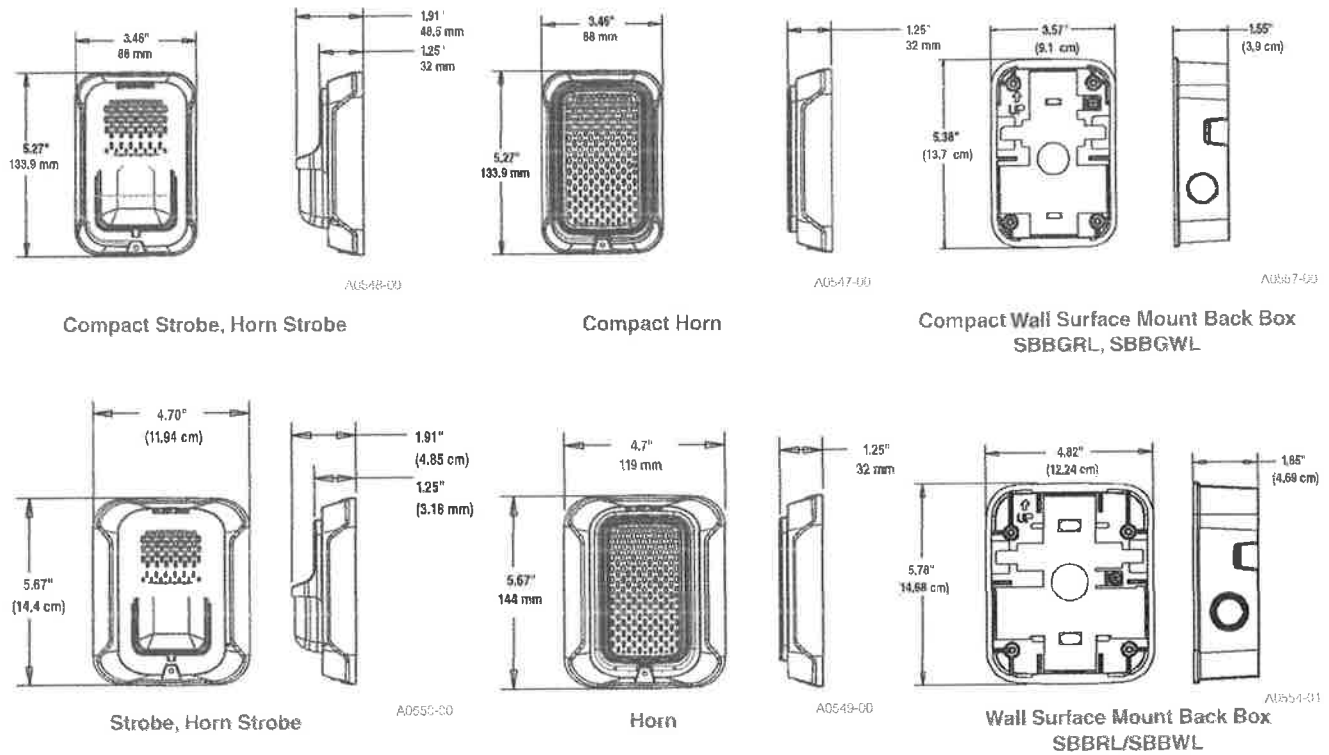

L-Series Ordering Information

Model	Description
Wall Horn Strobes	
P2RL	2-Wire, Horn Strobe, Red
P2WL	2-Wire, Horn Strobe, White
P2GRL	2-Wire, Compact Horn Strobe, Red
P2GWL	2-Wire, Comp 2 fil act Horn Strobe, White
P2RL-P	2-Wire, Horn Strobe, Red, Plain
P2WL-P	2-Wire, Horn Strobe, White, Plain
P2RL-SP	2-Wire, Horn Strobe, Red, FUEGO
P2WL-SP	2-Wire, Horn Strobe, White, FUEGO
P4RL	4-Wire, Horn Strobe, Red
P4WL	4-Wire, Horn Strobe, White
Wall Strobes	
SRL	Strobe, Red
SWL	Strobe, White
SGRL	Compact Strobe, Red
SGWL	Compact Strobe, White
SRL-P	Strobe, Red, Plain
SWL-P	Strobe, White, Plain
SRL-SP	Strobe, Red, FUEGO
SWL-CLR-ALERT	Strobe, White, ALERT

Model	Description
Horns*	
HRL*	Horn, Red
HWL*	Horn, White
HGRL*	Compact Horn, Red
HGWL*	Compact Horn, White
Accessories	
TR-2	Universal Wall Trim Ring Red
TR-2W	Universal Wall Trim Ring White
SBBRL	Wall Surface Mount Back Box, Red
SBBWL	Wall Surface Mount Back Box, White
SBBGRL	Compact Wall Surface Mount Back Box, Red
SBBGWL	Compact Wall Surface Mount Back Box, White

Notes:

All -P models have a plain housing (no "FIRE" marking on cover).
 All -SP models have "FUEGO" marking on cover.
 All -ALERT models have "ALERT" marking on cover.
 *Horn-only models are listed for wall or ceiling use.



3825 Ohio Avenue • St. Charles, IL 60174
 Phone: 800-SENSOR2 • Fax: 630-377-6495
www.systemsensor.com

©2018 System Sensor
 Product specifications subject to change without notice. Visit www.systemsensor.com
 for current product information, including the latest version of this data sheet.
 AVDS865-02 • 2/22/2018



Indoor Selectable-Output Speaker Strobes and Dual Voltage Evacuation Speakers for Wall Applications

System Sensor L-Series selectable output speaker strobes and dual-voltage evacuation speakers can reduce ground faults and enable faster installation with lower current draw and modern aesthetics.

Features

- Plug-in design and protective cover reduce ground faults
- Universal mounting plate with an onboard shorting spring tests wiring continuity before installation
- No extension ring required
- Field selectable candela settings on wall units: 15, 30, 75, 95, 110, 135, 185
- Automatic selection of 12- or 24-volt operation at 15 and 30 candela
- Rotary switch simplifies field selection of speaker voltage (25 and 70.7 Vrms) and power settings (¼, ½, 1 and 2 watts)
- Speakers offer high fidelity and high volume sound output
- 520 Hz +/- 10% square wave tone capable with compatible FACP
- Compatible with System Sensor synchronization protocol
- Electrical compatibility with existing SpectrAlert and SpectrAlert Advance products
- Tamper-resistant construction
- Updated modern aesthetics

Agency Listings



FM approved except for A_ERT models 3257410



3320-1831 0525



The System Sensor L-Series of speakers and speaker strobes reduce costly ground faults using a plug-in design and universal mounting plate that allow the installer to pre-wire mounting plates, dress the wires, and confirm wiring continuity before plugging in the speakers. In addition, a protective plastic cover prevents nicked wires by covering exposed speaker components.

These devices also enable faster installations by providing instant feedback to ensure that wiring is properly connected, rotary switches to select voltage and power settings, and 7 field-selectable candela settings for wall speaker strobes.

The low total harmonic distortion of the speaker offers high fidelity sound output while still offering high volume sound output for use in high ambient noise applications.

System Sensor L-Series makes installation easy

- Attach a universal mounting plate to a 4 x 4 x 2 1/8 inch back box. Flush-mount applications do not require an extension ring.
- Connect the notification appliance circuit or speaker wiring to the terminals on the mounting plate.
- Attach the speaker or speaker strobe to the mounting plate by inserting the product tabs into the mounting plate grooves. Hinge the device into position to lock the product pins into the mounting plate terminals. The device will temporarily hold in place with a catch until it is secured with a captured mounting screw.

L-Series Speaker and Speaker Strobe Specifications

Architectural/Engineering Specifications

General

L-Series speaker and speaker strobes shall mount to a 4 x 4 x 2 1/8-inch back box. A universal mounting plate shall be used for mounting ceiling and wall products. The notification appliance circuit and amplifier wiring shall terminate at the universal mounting plate. Also, L-Series speaker strobes, when used with the Sync•Circuit™ Module accessory, shall be powered from a non-coded notification appliance circuit output and shall operate on a nominal 12 or 24 volts. When used with the Sync•Circuit Module, 12-volt rated notification appliance circuit outputs shall operate between 8.5 and 17.5 volts; 24-volt rated notification appliance circuit outputs shall operate between 16.5 and 33 volts. Indoor L-Series products shall operate between 32°F and 120°F from a regulated DC, or full-wave rectified, unfiltered power supply. Wall-mount speaker strobes shall have field-selectable cardela settings including 15, 30, 75, 95, 110, 135, 185.

Speaker

N/A

The speaker shall be aSp System Sensor L-Series model _____ dual-voltage transformer speaker capable of operating at 25.0 or 70.7 nominal Vrms. It should be listed to UL 1480 and shall be approved for fire protective service. The speaker shall have a frequency range of 400 to 4,000 Hz and shall have an operating temperature between 32°F and 120°F. The speaker shall have power taps and voltage that are selected by rotary switches.

Speaker Strobe combination

SPSRL

The speaker strobe shall be a System Sensor L-Series model _____ listed to UL1480 and UL 1971 and be approved for fire protective signaling systems. The speaker shall be capable of operating at 25.0 or 70.7 nominal Vrms selected via rotary switch, and shall have a frequency range of 400 to 4,000 Hz. The speaker shall have power taps that are selected by rotary switch. The strobe shall comply with the NFPA 72 requirements for visible signaling appliances, flashing at 1 Hz over the strobe's entire operating voltage range. The strobe light shall consist of a xenon flash tube and associated lens/reflector system.

Synchronization Module

The module shall be a System Sensor Sync•Circuit model MDL3 listed to UL 464 and shall be approved for fire protective service. The module shall synchronize strobes at 1 Hz. The module shall mount to a 4 1/16 x 4 1/16 x 2 1/8-inch back box. The module shall also control two Style Y (class B) circuits or one Style Z (class A) circuit. The module shall synchronize multiple zones. Daisy chaining two or more synchronization modules together will synchronize all the zones they control. The module shall not operate on a coded power supply.

Physical Specifications

Operating Temperature	32°F to 120°F (0°C to 49°C)		
Humidity Range	10 to 93% non-condensing		
Dimensions, Wall-Mount	Length	Width	Depth
SPL Speaker	6.5 in, 165 mm	5 in, 127 mm	0.97 in, 23 mm
With Surface Mount Back Box	6.6 in, 168 mm	5.1 in, 130 mm	3.2 in, 82 mm
SPSL Speaker/Strobe (including lens and speaker)	6.5 in, 165 mm	5.0 in, 127 mm	2.3 in, 58 mm
With Surface Mount Back Box	6.6 in, 168 mm	5.1 in, 130 mm	4.5 in, 116 mm

*When using 12AWG, 14 AWG, or adding extra wires in the box, a deeper box or extension ring is recommended.

Electrical/Operating Specifications

Nominal Voltage (speakers)	25 Volts or 70.7 Volts (nominal)
Maximum Supervisory Voltage (speakers)	50 VDC
Strobe Flash Rate	1 flash per second
Nominal Voltage (strobes)	Regulated 12 VDC or regulated 24 DC/FWR ^{1,2}
Operating Voltage Range (includes fire alarm panels with built in sync)	8 to 17.5 V (12 V nominal) or 16 to 33 V (24 V nominal)
Operating Voltage with MDL3 Sync Module	8.5 to 17.5 V (12 V nominal) or 16.5 to 33 V (24 V nominal)
Frequency Range	400 to 4000 Hz ³
Power	¼, ½, 1, 2 watts

1. Full Wave Rectified (FWR) voltage is a non-regulated, time-varying power source that is used on some power supply and panel outputs.

2. Strobe products will operate at 12 V nominal only for 15 and 30 cfd

3. 520 Hz +/- 10% square wave tone capable with compatible FACP.

UL Current Draw Data

UL Max Strobe Current Draw (mA RMS)			
Candela	8 to 17.5 Volts		16 to 33 Volts
	DC		DC FWR
15	88		60
30	143		83
75	N/A	107	136
95	N/A	121	155
110	N/A	148	179
135	N/A	172	209
185	N/A	222	257

Sound Output Speaker Strobe				
	¼ W	½ W	1 W	2 W
UL Reverberant (dBA @10 ft)	77	80	83	86
UL Anechoic (dBA @10 ft)	77	80	83	86

Sound Output Speaker				
	¼ W	½ W	1 W	2 W
UL Reverberant (dBA @10 ft)	79	82	85	88
UL Anechoic (dBA @10 ft)	79	82	85	88

L-Series Dimensions

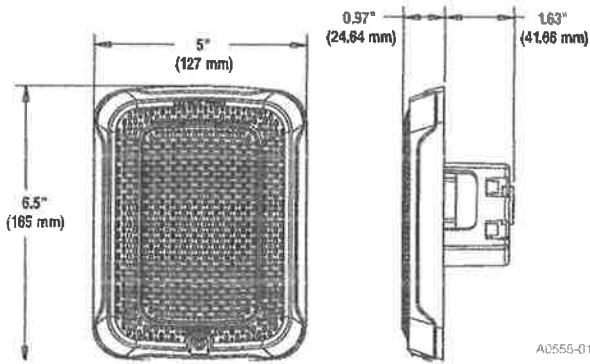

Wall-Mount Speaker

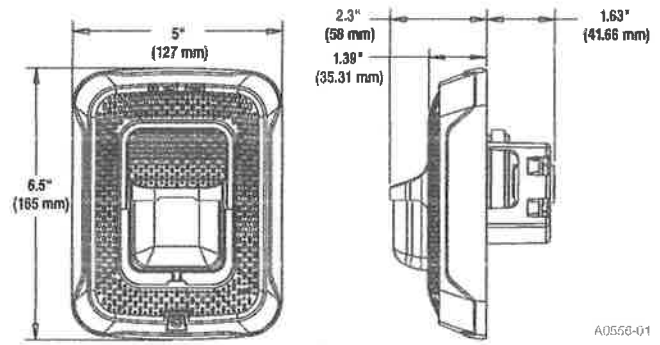

Wall-Mount Speaker Strobe

Surface Mounting

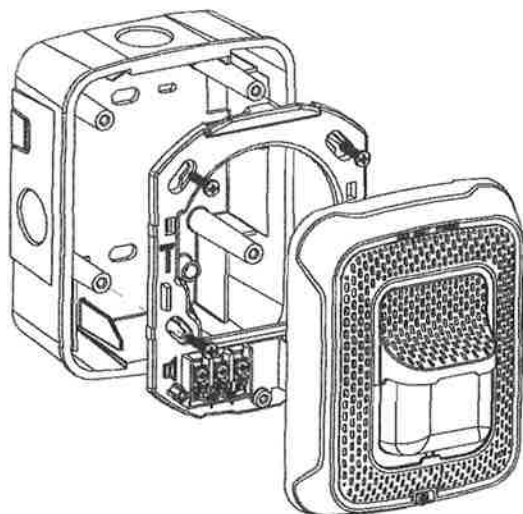

A1202431

Wall-Mount Speaker Strobe
with SBBSPRL/ SBBSPWL Surface Mount Back Box

L-Series Ordering Information

Wall Mount		
White	Red	Description
SPWL	SPRL	Speaker only
SPSWL	SPSRL	Speaker Strobe
SPSWL-P	SPSRL-P	Plain Speaker Strobe
SPSWL-ALERT	—	Speaker Strobe, Amber Lens
SPSWL-CLR-ALERT	—	Speaker Strobe Clear Lens
—	SPSRL-SP	Speaker Strobe, Fuego

Accessories		
White	Red	Description
RFPW	RFP	7 in x 9.5 in Retrofit Plate
SBBSPWL	SBBSPRL	Surface Mount Back Box for Speakers and Speaker Strobes
TR-2W	TR-2	Wall Mount Trim Ring

Notes:

All -P models have a plain housing (no "FIRE" marking on the cover)



3825 Ohio Avenue • St. Charles, IL 60174
Phone: 800-SENSOR2 • Fax: 630-377-6495
www.systemsensor.com

©2018 System Sensor.
Product specifications subject to change without notice. Visit systemsensor.com
for current product information, including the latest version of this data sheet.
AVD5867-02 • 03/23/2018



Indoor Selectable-Output Speaker Strobes and Dual Voltage Evacuation Speakers for Ceiling Applications

System Sensor L-Series selectable-output speaker strobes and dual-voltage evacuation speakers can reduce ground faults and enable faster installation with lower current draw and modern aesthetics.

Features

- Plug-in design and protective cover reduce ground faults
- Universal mounting plate with an onboard shorting spring tests wiring continuity before installation
- No extension ring required
- Field selectable candela settings on ceiling units: 15, 30, 75, 95, 115, 150, and 177
- Automatic selection of 12- or 24-volt operation at 15 and 30 candela
- Rotary switch simplifies field selection of speaker voltage (25 and 70.7 Vrms) and power settings (¼, ½, 1 and 2 watts)
- Speakers offer high fidelity and high volume sound output
- 520 Hz +/- 10% square wave tone capable with compatible FACP
- Compatible with System Sensor synchronization protocol
- Electrical compatibility with existing SpectrAlert and SpectrAlert Advance products
- Tamper-resistant construction
- Updated modern aesthetics

Agency Listings



File approved except for A_LERT models
3057495

1520-100A-000

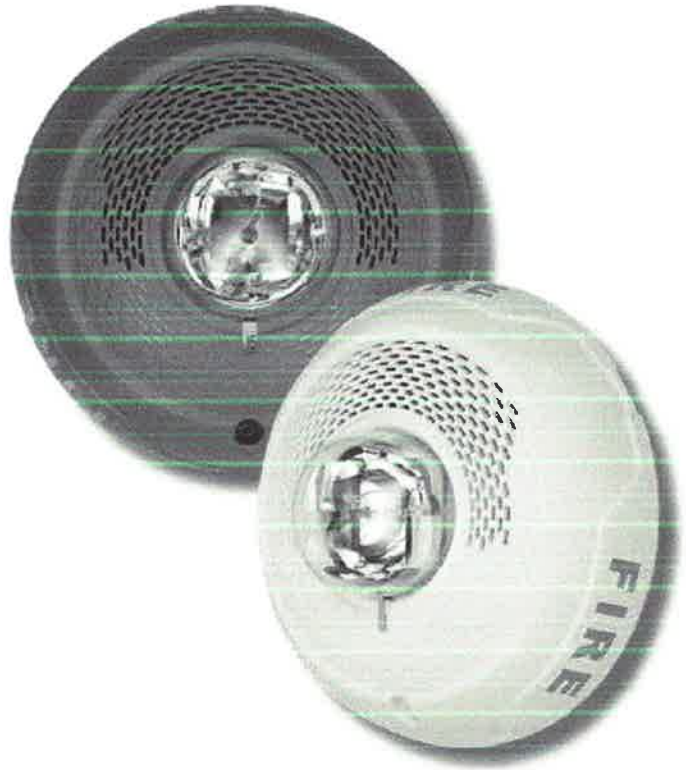

System Sensor L-Series of speakers and speaker strobes reduce costly ground faults using a plug-in design and universal mounting plate that allow the installer to pre-wire mounting plates, dress the wires, and confirm wiring continuity before plugging in the speakers. In addition, a protective plastic cover prevents nicked wires by covering exposed speaker components.

These devices also enable faster installations by providing instant feedback to ensure that wiring is properly connected, rotary switches to select voltage and power settings, and 7 field-selectable candela settings for both wall and ceiling speaker strobes.

The low total harmonic distortion of the SP speaker offers high fidelity sound output while still offering high volume sound output for use in high ambient noise applications.

L-Series makes installation easy

- Attach a universal mounting plate to a 4 x 4 x 2 1/8 inch back box. Flush-mount applications do not require an extension ring.
- Connect the notification appliance circuit or speaker wiring to the terminals on the mounting plate.
- Attach the speaker or speaker strobe to the mounting plate by inserting the product tabs into the mounting plate grooves. Hinge the device into position to lock the product pins into the mounting plate terminals. The device will temporarily hold in place with a catch until it is secured with a captured mounting screw.

L-Series Speaker and Speaker Strobe Specifications

Architectural/Engineering Specifications

General

L-Series speaker and speaker strobes shall mount to a 4 x 4 x 2 1/8-inch back box. A universal mounting plate shall be used for mounting ceiling and wall products. The notification appliance circuit and amplifier wiring shall terminate at the universal mounting plate. Also, L-Series speaker strobes, when used with the Sync•Circuit™ Module accessory, shall be powered from a non-coded notification appliance circuit output and shall operate on a nominal 12 or 24 volts. When used with the Sync•Circuit Module, 12-volt rated notification appliance circuit outputs shall operate between 8.5 and 17.5 volts; 24-volt rated notification appliance circuit outputs shall operate between 16.5 and 33 volts. Indoor L-Series products shall operate between 32°F and 120°F from a regulated DC, or full-wave rectified, unfiltered power supply. Speaker strobes shall have field-selectable candela settings including 15, 30, 75, 95, 115, 150, 177.

Speaker

N/A

The speaker shall be a System Sensor L-Series model _____ dual-voltage transformer speaker capable of operating at 25.0 or 70.7 nominal Vrms. It should be listed to UL 1480 and shall be approved for fire protective service. The speaker shall have a frequency range of 400 to 4,000 Hz and shall have an operating temperature between 32°F and 120°F. The speaker shall have power taps and voltage that are selected by rotary switches.

Speaker Strobe combination

SPSCRL

The speaker strobe shall be a System Sensor L-Series model _____ listed to UL 1480 and UL 1971 and be approved for fire protective signaling systems. The speaker shall be capable of operating at 25.0 or 70.7 nominal Vrms selected via rotary switch, and shall have a frequency range of 400 to 4,000 Hz. The speaker shall have power taps that are selected by rotary switch. The strobe shall comply with the NFPA 72 requirements for visible signaling appliances, flashing at 1 Hz over the strobe's entire operating voltage range. The strobe light shall consist of a xenon flash tube and associated lens/reflector system.

Synchronization Module

The module shall be a System Sensor Sync•Circuit model MDL3 listed to UL 464 and shall be approved for fire protective service. The module shall synchronize SpectraAlert strobes at 1 Hz. The module shall mount to a 4 1/16 x 4 1/16 x 2 1/8-inch back box. The module shall also control two Style Y (class B) circuits or one Style Z (class A) circuit. The module shall synchronize multiple zones. Daisy chaining two or more synchronization modules together will synchronize all the zones they control. The module shall not operate on a coded power supply.

Physical Specifications

Operating Temperature	32°F to 120°F (0°C to 49°C)	
Humidity Range	10 to 93% non-condensing	
Dimensions, Ceiling-Mount	Diameter	Depth
SPC Speaker	6.8 in, 173 mm	1.0 in, 25 mm
With Surface Mount Back Box	6.9 in, 176 mm	3.5 in, 89 mm
SPSC Speaker Strobe	6.8 in, 173 mm	2.8 in, 73 mm
With Surface Mount Back Box	6.9 in, 176 mm	5.37 in, 136 mm

*When using 12AWG, 14 AWG, or adding extra wires in the box, a deeper box or extension ring is recommended.

Electrical/Operating Specifications

Nominal Voltage (speakers)	25 Volts or 70.7 Volts (nominal)
Maximum Supervisory Voltage (speakers)	50 VDC
Strobe Flash Rate	1 flash per second
Nominal Voltage (strobes)	Regulated 12 VDC or regulated 24 VDC/FWR ^{1,2}
Operating Voltage Range (includes fire alarm panels with built in sync)	8 to 17.5 V (12 V nominal) or 16 to 33 V (24 V nominal)
Operating Voltage with MDL3 Sync Module	8.5 to 17.5 V (12 V nominal) or 16.5 to 33 V (24 V nominal)
Frequency Range	400 to 4,000 Hz ³
Power	1/4, 1/2, 1, 2 watts

1. Full Wave Rectified (FWR) voltage is a non-regulated, time-varying power source that is used on some power supply and panel outputs.
2. Strobe products will operate at 12 V nominal only for 15 and 30 cd.
3. 520 Hz +/- 10% square wave tone capable with compatible FACP.

UL Current Draw Data

UL Max. Strobe Current Draw (mA RMS)			
Candela	8 to 17.5 Volts		16 to 33 Volts
	DC	DC	FWR
15	87	41	60
30	153	63	86
75	NA	111	142
95	NA	134	164
115	NA	158	191
150	NA	189	228
177	NA	226	264

Ceiling-Mount Speaker Sound Output		
Setting	UL Reverberant (dBA @ 10 ft)	UL Anechoic (dBA @ 10 ft)
1/4 W	79	79
1/2 W	82	82
1 W	85	85
2 W	88	88

Ceiling-Mount Speaker Strobe Sound Output		
Setting	UL Reverberant (dBA @ 10 ft)	UL Anechoic (dBA @ 10 ft)
1/4 W	77	77
1/2 W	80	80
1 W	83	83
2 W	86	86

L-Series Dimensions

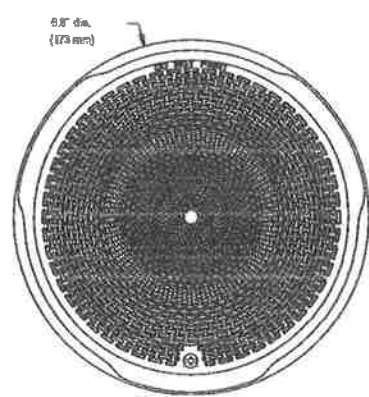

Ceiling Speaker

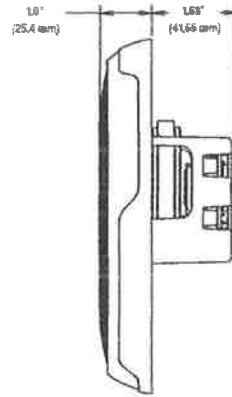

A0543-00

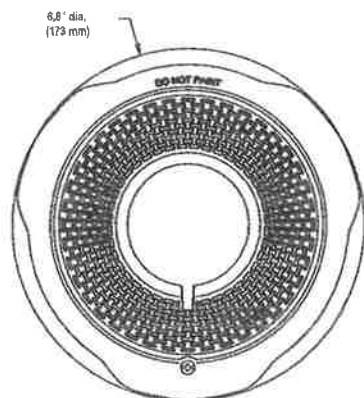

Ceiling Speaker Strobe

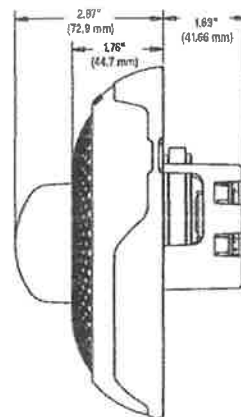

A0544-00

Surface Mounting

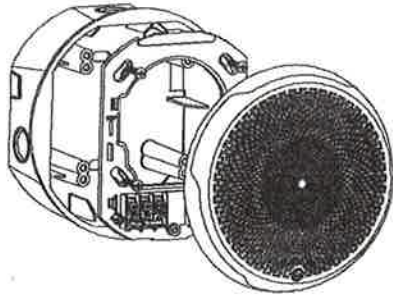

A0504-01

Ceiling Speaker with Surface Mount Back Box

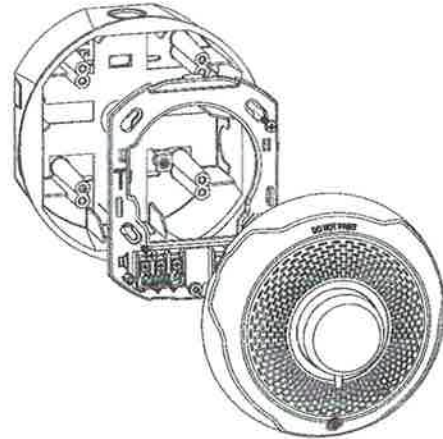

A0520-01

Ceiling Speaker Strobe with Surface Mount Back Box

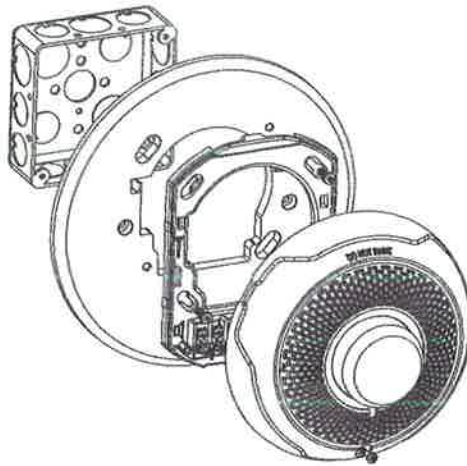

A0542-00

Ceiling Speaker Strobe with Trim Ring and 4" Square Electrical Box

L-Series Ordering Information

Ceiling Mount		
White	Red	Description
SPCWL	SPCRL	Speaker only
SPSCWL	SPSCRL	Speaker Strobe
SPSCWL-P	—	Plain, Speaker Strobe
SPSCWL-SP	—	Fuego, Speaker Strobe
SPSCWL-CLR-ALERT	—	Alert, Speaker Strobe, Clear Lens

Accessories		
White	Red	Description
SBBCWL	SBBCRL	Universal Ceiling Surface Mount Back Box
TRC-2W	TRC-2	Universal Ceiling Trim Ring



3825 Ohio Avenue • St. Charles, IL 60174
 Phone: 800-SENSOR2 • Fax: 630-377-6495
www.systemsensor.com

©2018 System Sensor.
 Product specifications subject to change without notice. Visit systemsensor.com
 for current product information, including the latest version of this data sheet.
 AVDS266-03 • 03/29/2018

CRF-300(A)

Relay Module



Addressable Devices

General

The CRF-300(A) Addressable Relay Module provides the system with a dry-contact output for activating a variety of auxiliary devices, such as fans, door holders, dampers, control equipment, etc. Addressability allows the dry contact to be activated through panel programming, on a select basis.

LiteSpeed™ is a communication protocol developed by Fire-Lite Engineering that greatly enhances the speed of communication between analog intelligent devices. Intelligent devices communicate in a grouped fashion. If one of the devices within the group has new information, the panel CPU stops the group poll and concentrates on single points. The net effect is response speed greater than five times that of other designs.

Features

- Built-in type identification automatically identifies these devices to the control panel.
- Internal circuitry and relay powered directly by two-wire SLC loop.
- Integral LED "blinks" green each time a communication is received from the control panel and turns on in steady red when activated.
- High noise immunity (EMF/RFI).
- Wide viewing angle of LED.
- SEMS screws with clamping plates for wiring ease.
- Direct-dial entry of address: 01–159 for MS-9600(A) series panels, 01–99 on MS-9200UDLS(A) and MS-9050UD(A).

Applications

The CRF-300(A) may be programmed to operate dry contacts for door holders, Air Handling Unit shutdown, etc., and to reset four-wire smoke detector power.

Construction

- The face plate is made of off-white heat-resistant plastic.
- Controls include two rotary switches for direct-dial entry of address setting.
- The CRF-300(A) is configured for a single Class B (Style Y) or Class A (Style Z) Notification Appliance Circuit.
- The CRF-300(A) provides two Form-C dry contacts that switch together.

Operation

Each CRF-300(A) uses one of the addresses on a SLC loop. It responds to regular polls from the control panel and reports its type and status, including the open/normal/short status of its Notification Appliance Circuit (NAC). The LED blinks with each poll received. On command, it activates its internal relay.

NOTE: Open/short supervision is suspended with the CRF-300.

Rotary switches set a unique address for each module. The address may be set before or after mounting. The built-in TYPE CODE (not settable) will identify the module to the control panel, so as to differentiate between a control module and a relay module.



CRF-300(A)

Specifications

Normal operating voltage: 15 to 32 VDC.

Maximum SLC current draw: 6.5 mA (LED on).

Average operating current: 230 μ A direct poll (CLIP mode), 255 μ A group poll (LiteSpeed mode) with LED flashing.

EOL resistance: not used.

Temperature range: 32°F to 120°F (0°C to 49°C).

Humidity range: 10% to 93% non-condensing.

Dimensions: 4.5" (11.43 cm) high x 4" (10.16 cm) wide x 1.25" (3.175 cm) deep. Mounts to a 4" (10.16 cm) square x 2.125" (5.398 mm) deep box.

Relay Contact Ratings

Load Description	Application	Maximum Voltage	Current Rating
Resistive	Non-Coded	30 VDC	3.0 A
Resistive	Coded	30 VDC	2.0 A
Resistive	Non-Coded	110 VDC	0.9 A
Resistive	Non-Coded	125 VAC	0.9 A
Inductive (L/R=5ms)	Coded	30 VDC	0.5 A
Inductive (L/R=2ms)	Coded	30 VDC	1.0 A
Inductive (PF=0.35)	Non-Coded	125 VAC	0.5 A

Agency Listings and Approvals

In some cases, certain modules may not be listed by certain approval agencies, or listing may be in process. Consult factory for latest listing status.

- UL: S2424
- ULC: S2424
- FM approved
- CSFM: 7300-0075:185
- MEA: 72-01-E

Product Line Information

CRF-300(A): Intelligent addressable relay module.

: Intelligent addressable relay module, ULC listed model.

SMB500: Optional surface-mount backbox.

NOTE: For installation instructions, see document 156-1190-005 and refer to the SLC Wiring Manual, document 51309.

LiteSpeed™ is a trademark and Fire•Lite® Alarms is a registered trademark of Honeywell International Inc.
©2009 by Honeywell International Inc. All rights reserved. Unauthorized use of this document is strictly prohibited.



This document is not intended to be used for installation purposes.
We try to keep our product information up-to-date and accurate.
We cannot cover all specific applications or anticipate all requirements.
All specifications are subject to change without notice.



Made in the U.S. A.

For more information, contact Fire•Lite Alarms. Phone: (800) 627-3473, FAX: (877) 699-4105.
www.firelite.com

MMF-300(A) Series, MDF-300

Addressable Monitor Modules



Addressable Devices

General

Four different monitor modules are available for Fire-Lite's intelligent control panels to suit a variety of applications. Monitor modules are used to supervise a circuit of dry-contact input devices, such as conventional heat detectors and pull stations, or monitor and power a circuit of two-wire smoke detectors (MMF-302(A)).

MMF-300(A) is a standard-sized module (typically mounts to a 4" [10.16 cm] square box) that supervises either a Style D (Class A) or Style B (Class B) circuit of dry-contact input devices.

MMF-301(A) is a miniature monitor module a mere 1.3" (3.302 cm) H x 2.75" (6.985 cm) W x 0.65" (1.651 cm) D that supervises a Style B (Class B) circuit of dry-contact input devices. Its compact design allows the MMF-301(A) to be mounted in a single-gang box behind the device it monitors.

MMF-302(A) is a standard-sized module used to monitor and supervise compatible two-wire, 24 volt, smoke detectors on a Style D (Class A) or Style B (Class B) circuit.

MDF-300(A) is a standard-sized dual monitor module used to monitor and supervise two independent two-wire Style B (Class B) dry-contact initiating device circuits (IDCs) at two separate, consecutive addresses in intelligent, two-wire systems.

LiteSpeed™ is a communication protocol developed by Fire-Lite Engineering that greatly increases the speed of communication between analog intelligent devices. Intelligent devices communicate in a grouped fashion. If one of the devices within the group has new information, the panel CPU stops the group poll and concentrates on single points. The net effect is response speed greater than five times that of other communication protocols.

MMF-300(A) Monitor Module

- Built-in type identification automatically identifies this device as a monitor module to the control panel.
- Powered directly by two-wire SLC loop. No additional power required.
- High noise (EMF/RFI) immunity.
- SEMS screws with clamping plates for ease of wiring.
- Direct-dial entry of address: 01 – 159 on MS-9600 series panels, 01 – 99 on other compatible systems.
- LED flashes during normal operation and latches on steady to indicate alarm.

The MMF-300(A) Monitor Module is intended for use in intelligent, two-wire systems, where the individual address of each module is selected using the built-in rotary switches. It provides either a two-wire or four-wire fault-tolerant Initiating Device Circuit (IDC) for normally-open-contact fire alarm and supervisory devices. The module has a panel-controlled LED indicator. The MMF-300(A) can be used to replace M300(A) modules in existing systems.

MMF-300(A) APPLICATIONS

Use to monitor a zone of four-wire smoke detectors, manual fire alarm pull stations, waterflow devices, or other normally-open dry-contact alarm activation devices. May also be used to monitor normally-open supervisory devices with special

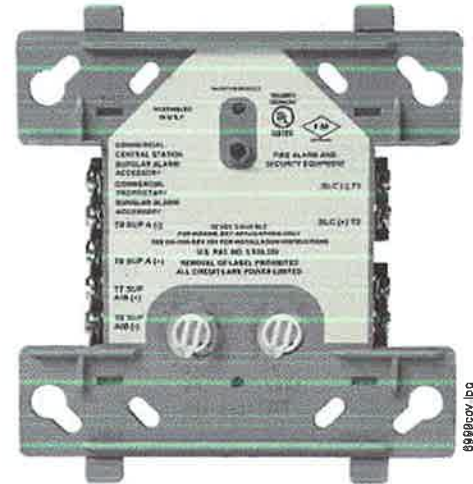

MMF-300(A) (Type H)

supervisory indication at the control panel. Monitored circuit may be wired as an NFPA Style B (Class B) or Style D (Class A) Initiating Device Circuit. A 47k Ohm End-of-Line Resistor (provided) terminates the Style B circuit. No resistor is required for supervision of the Style D circuit.

MMF-300(A) OPERATION

Each MMF-300(A) uses one of the available module addresses on an SLC loop. It responds to regular polls from the control panel and reports its type and the status (open/normal/short) of its Initiating Device Circuit (IDC). A flashing LED indicates that the module is in communication with the control panel. The LED latches steady on alarm (subject to current limitations on the loop).

MMF-300(A) SPECIFICATIONS

Nominal operating voltage: 15 to 32 VDC.

Maximum current draw: 5.0 mA (LED on).

Average operating current: 375 µA (LED flashing), 1 communication every 5 seconds, 47k EOL.

Maximum IDC wiring resistance: 1500 Ohms.

Maximum IDC Voltage: 11 Volts.

EOL resistance: 47k Ohms.

Temperature range: 32°F to 120°F (0°C to 49°C).

Humidity range: 10% to 93% noncondensing.

Dimensions: 4.5" (11.43 cm) high x 4" (10.16 cm) wide x 1.25" (3.175 cm) deep. Mounts to a 4" (10.16 cm) square x 2.125" (5.398 cm) deep box.

MMF-301(A) Mini Monitor Module

- Built-in type identification automatically identifies this device as a monitor module to the panel.
- Powered directly by two-wire SLC loop. No additional power required.
- High noise (EMF/RFI) immunity.

- Tinned, stripped leads for ease of wiring.
- Direct-dial entry of address: 01 – 159 on MS-9600 series panels, 01 – 99 on other compatible systems

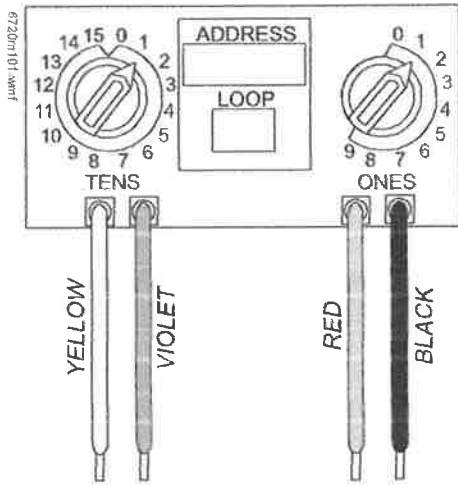

The MMF-301(A) Mini Monitor Module can be installed in a single-gang junction directly behind the monitored unit. Its small size and light weight allow it to be installed without rigid mounting. The MMF-301(A) is intended for use in intelligent, two-wire systems where the individual address of each module is selected using rotary switches. It provides a two-wire initiating device circuit for normally-open-contact fire alarm devices. The MMF-301(A) can be used to replace M301(A) modules in existing systems.

MMF-301(A) APPLICATIONS

Use to monitor a single device or a zone of four-wire smoke detectors, manual fire alarm pull stations, waterflow devices, or other normally-open dry-contact devices. May also be used to monitor normally-open supervisory devices with special supervisory indication at the control panel. Monitored circuit/device is wired as an NFPA Style B (Class B) Initiating Device Circuit. A 47K Ohm End-of-Line Resistor (provided) terminates the circuit.

MMF-301(A) OPERATION

Each MMF-301(A) uses one of the available module addresses on an SLC loop. It responds to regular polls from the control panel and reports its type and the status (open/normal/short) of its Initiating Device Circuit (IDC).

MMF-301(A) SPECIFICATIONS

- Nominal operating voltage:** 15 to 32 VDC.
- Average operating current:** 350 μ A, 1 communication every 5 seconds, 47k EOL; 600 μ A Max. (Communicating, IDC Shorted).
- Maximum IDC wiring resistance:** 1500 Ohms.
- Maximum IDC Voltage:** 11 Volts.
- Maximum IDC Current:** 450 μ A.
- EOL resistance:** 47K Ohms.
- Temperature range:** 32°F to 120°F (0°C to 49°C).
- Humidity range:** 10% to 93% noncondensing.
- Dimensions:** 1.3" (3.302 cm) high x 2.75" (6.985 cm) wide x 0.65" (1.651 cm) deep.
- Wire length:** 6" (15.24 cm) minimum.

MMF-302(A) Interface Module

- Supports compatible two-wire smoke detectors.

- Supervises IDC wiring and connection of external power source.
- High noise (EMF/RFI) immunity.
- SEMS screws with clamping plates for ease of wiring.
- Direct-dial entry of address: 01 – 159 on MS-9600 series panels, 01 – 99 on other compatible systems.
- LED flashes during normal operation.
- LED latches steady to indicate alarm on command from control panel.

The MMF-302(A) Interface Module is intended for use in intelligent, addressable systems, where the individual address of each module is selected using built-in rotary switches. This module allows intelligent panels to interface and monitor two-wire conventional smoke detectors. It transmits the status (normal, open, or alarm) of one full zone of conventional detectors back to the control panel. All two-wire detectors being monitored must be UL compatible with the module. The MMF-302(A) can be used to replace M302(A) modules in existing systems.

MMF-302 (A) APPLICATIONS

Use the MMF-302(A) to monitor a zone of two-wire smoke detectors. The monitored circuit may be wired as an NFPA Style B (Class B) or Style D (Class A) Initiating Device Circuit. A 3.9 K Ohm End-of-Line Resistor (provided) terminates the end of the Style B or D (class B or A) circuit (maximum IDC loop resistance is 25 Ohms). Install ELR across terminals 8 and 9 for Style D application.

MMF-302(A) OPERATION

Each MMF-302(A) uses one of the available module addresses on an SLC loop. It responds to regular polls from the control panel and reports its type and the status (open/normal/short) of its Initiating Device Circuit (IDC). A flashing LED indicates that the module is in communication with the control panel. The LED latches steady on alarm (subject to current limitations on the loop).

MMF-302(A) SPECIFICATIONS

- Nominal operating voltage:** 15 to 32 VDC.
- Maximum current draw:** 5.1 mA (LED on).
- Maximum IDC wiring resistance:** 25 Ohms.
- Average operating current:** 270 μ A, 1 communication and 1 LED flash every 5 seconds, 3.9k eol.
- EOL resistance:** 3.9K Ohms.
- External supply voltage (between Terminals T10 and T11):**
 - DC voltage: 24 volts power limited.
 - Ripple voltage: 0.1 Vrms maximum.
 - Current: 90 mA per module maximum.
- Temperature range:** 32°F to 120°F (0°C to 49°C).
- Humidity range:** 10% to 93% noncondensing.
- Dimensions:** 4.5" (11.43 cm) high x 4" (10.16 cm) wide x 1.25" (3.175 cm) deep. Mounts to a 4" (10.16 cm) square x 2.125" (5.398 cm) deep box.

MDF-300(A) Dual Monitor Module

The MDF-300(A) Dual Monitor Module is intended for use in intelligent, two-wire systems. It provides two independent two-wire initiating device circuits (IDCs) at two separate, consecutive addresses. It is capable of monitoring normally open contact fire alarm and supervisory devices. The module has a single panel-controlled LED.

NOTE: The MDF-300(A) provides two Style B (Class B) IDC circuits ONLY. Style D (Class A) IDC circuits are NOT supported in any application.

MDF-300(A) SPECIFICATIONS

Normal operating voltage range: 15 to 32 VDC.

Maximum current draw: 6.4 mA (LED on).

Average operating current: 750 μ A (LED flashing).

Maximum IDC wiring resistance: 1,500 Ohms.

Maximum IDC Voltage: 11 Volts.

Maximum IDC Current: 240 μ A

EOL resistance: 47K Ohms.

Temperature range: 32° to 120°F (0° to 49°C).

Humidity range: 10% to 93% (non-condensing).

Dimensions: 4.5" (11.43 cm) high x 4" (10.16 cm) wide x 1.25" (3.175 cm) deep. Mounts to a 4" (10.16 cm) square x 2.125" (5.398 cm) deep box.

MDF-300(A) AUTOMATIC ADDRESSING

The MDF-300(A) automatically assigns itself to two addressable points, starting with the original address. For example, if the MDF-300(A) is set to address "26", then it will automatically assign itself to addresses "26" and "27".

NOTE: "Ones" addresses on the MDF-300(A) are 0, 2, 4, 6, or 8 only. Terminals 6 and 7 use the first address, and terminals 8 and 9 use the second address.

CAUTION:

Avoid duplicating addresses on the system.

MDF-300(A): Monitor module, dual, two independent Class B circuits.

SMB500: Optional surface-mount backbox.

NOTE: See installation instructions and refer to the SLC Wiring Manual, PN 51309.

Architects'/Engineers' Specifications

Specifications of these devices and all FireLite products are available from FireLite.

Installation

MMF-300(A), MMF-302(A), and MDF-300(A) modules mount directly to a standard 4" (10.16 cm) square, 2.125" (5.398 cm) deep, electrical box. They may also be mounted to the SMB500 surface-mount box. Mounting hardware and installation instructions are provided with each module. All wiring must conform to applicable local codes, ordinances, and regulations. These modules are intended for power-limited wiring only.

The MMF-301(A) module is intended to be wired and mounted without rigid connections inside a standard electrical box. All wiring must conform to applicable local codes, ordinances, and regulations.

Agency Listings and Approvals

In some cases, certain modules may not be listed by certain approval agencies, or listing may be in process. Consult factory for latest listing status.

- **UL:** S2424.
- **ULC:** S2424.
- **FM Approved.**
- **CSFM:** 7300-0075:0185.
- **MEA:** 72-01-E.

Product Line Information

NOTE: "A" suffix indicates ULC-listed model.

MMF-300(A): Monitor module.

MMF-301(A): Monitor module, miniature.

MMF-302(A): Monitor module, two-wire detectors.

BG-12LX

Addressable Manual Pull Station



Addressable Devices

General

The Fire-Lite BG-12LX is a state-of-the-art, dual-action (i.e., requires two motions to activate the station) pull station that includes an addressable interface (mounted inside) for Fire-Lite's addressable fire alarm control panels (FACPs). Because the BG-12LX is addressable, the control panel can display the exact location of the activated manual station. This leads fire personnel quickly to the location of the alarm.

Features

- Maintenance personnel can open station for inspection and address setting without causing an alarm condition.
- Built-in bicolor LED, which is visible through the handle of the station, flashes in normal operation and latches steady red when in alarm.
- Handle latches in down position and the word "ACTIVATED" appears to clearly indicate the station has been operated.
- Captive screw terminals wire-ready for easy connection to SLC loop (accepts up to 12 AWG/3.25 mm² wire).
- Can be surface mounted (with SB-10 or SB-I/O) or semi-flush mounted. Semi-flush mount to a standard single-gang, double-gang, or 4" (10.16 cm) square electrical box.
- Smooth dual-action design.
- Meets ADAAG controls and operating mechanisms guidelines (Section 4.1.3[13]); meets ADA requirement for 5 lb. maximum activation force.
- Highly visible.
- Attractive shape and textured finish.
- Key reset.
- Includes Braille text on station handle.
- Optional trim ring (BG12TR).
- Meets UL 38, Standard for Manually Actuated Signaling Boxes.

Construction

Shell, door, and handle are molded of durable polycarbonate material with a textured finish.

Specifications

- **Shipping Weight:** 9.6 oz. (272.15 g)
- **Normal operating voltage:** 24 VDC.
- **Maximum SLC loop voltage:** 28.0 VDC.
- **Maximum SLC standby current:** 375 μ A.
- **Maximum SLC alarm current:** 5 mA.
- **Temperature Range:** 32°F to 120°F (0°C to 49°C)
- **Relative Humidity:** 10% to 93% (noncondensing)
- **For use indoors in a dry location**

Installation

The BG-12LX will mount semi-flush into a single-gang, double-gang, or standard 4" (10.16 cm) square electrical outlet box, or will surface mount to the model SB-10 or SB-I/O surface backbox. If the BG-12LX is being semi-flush mounted, then the optional trim ring (BG12TR) may be used. The BG12TR is



FL-PullStation.jpg

usually needed for semi-flush mounting with 4" (10.16 cm) or double-gang boxes (not with single-gang boxes).

Operation

Pushing in, then pulling down on the handle causes it to latch in the down/activated position. Once latched, the word "ACTIVATED" (in bright yellow) appears at the top of the handle, while a portion of the handle protrudes from the bottom of the station. To reset the station, simply unlock the station with the key and pull the door open. This action resets the handle; closing the door automatically resets the switch.

Each manual station, on command from the control panel, sends data to the panel representing the state of the manual switch. Two rotary decimal switches allow address settings (1 – 159 with Breakaway Tab removed for MS-9600 Series, 1 – 99 and MS-9200UDLS, 1 – 50 for MS-9050UD).

Architectural/Engineering Specifications

Manual Fire Alarm Stations shall be non-coded, with a key-operated reset lock in order that they may be tested, and so designed that after actual Emergency Operation, they cannot be restored to normal except by use of a key. An operated station shall automatically condition itself so as to be visually detected as activated. Manual stations shall be constructed of red-colored polycarbonate material with clearly visible operating instructions provided on the cover. The word FIRE shall appear on the front of the stations in white letters, 1.00 inches (2.54 cm) or larger. Stations shall be suitable for surface mounting on matching backbox SB-10 or SB-I/O; or semi-flush mounting on a standard single-gang, double-gang, or 4" (10.16 cm) square electrical box, and shall be installed

within the limits defined by the Americans with Disabilities Act (ADA) or per national/local requirements. Manual Stations shall be Underwriters Laboratories listed.

Manual stations shall connect with two wires to one of the control panel SLC loops. The manual station shall, on command from the control panel, send data to the panel representing the state of the manual switch. Manual stations shall provide address setting by use of rotary decimal switches.

Product Line Information

BG-12LX: Dual-action addressable pull station. Includes key locking feature. (Listed for Canadian and non-Canadian applications.)

SB-10: Surface backbox; metal.

SB-I/O: Surface backbox; plastic.

BG12TR: Optional trim ring.

17003: Keys, set of two.

Agency Listings and Approvals

In some cases, certain modules or applications may not be listed by certain approval agencies, or listing may be in process. Consult factory for latest listing status.

- **UL/ULC Listed:** S711 (listed for Canadian and non-Canadian applications).
- **MEA:** 67-02-E.
- **CSFM:** 7150-0075:0184.
- **FM Approved.**

Patented: U.S. Patent No. D428,351; 6,380,846; 6,314,772; 6,632,108.

FireLite® Alarms® is a registered trademark of Honeywell International Inc. ©2012 by Honeywell International Inc. All rights reserved. Unauthorized use of this document is strictly prohibited.



This document is not intended to be used for installation purposes.
We try to keep our product information up-to-date and accurate.
We cannot cover all specific applications or anticipate all requirements.
All specifications are subject to change without notice.



Made in the U.S. A.

For more information, contact Fire-Lite Alarms. Phone: (800) 627-3473, FAX: (877) 699-4105.
www.firelite.com

-GENESIS-

Plenum Rated Power Limited Fire Alarm Cable

Part Number: 4511

16 AWG 2 Solid Conductors

Ratings FPLP, CL3P, FT6

Approvals UL Listed

Construction

Conductor 16 AWG Solid Bare Copper

Conductor Count 2

Insulation Plenum PVC (0.009" nom.)

Insulation Colors Black, Red

Lay Length 4.25" nom.

Shielding N/A

Rip Cord Yes

Jacket Plenum PVC (0.015 " nom.)

Overall Diameter 0.177" nom.

Print Legend GENESIS P/N 4511 2C 16AWG E175105 (UL) FPLP OR CL3P FT6 75C (RoHS) W/O#
XXXXXX-XXXXXXX XXXXFT A B C D E F 1 2 3 4 5 6 7 8 9

Properties

Operating Voltage 300 Volts max.

DC Resistance 4.1 Ohms/1000' at 20°C

Capacitance 21.8 pF/ft. nom.

Impedance 66 Ohms nom.

Temperature -20°C to 75°C

Flame Rating NFPA 262 (Plenum); CSA C22.2 No. 2556 (FT6)

RoHS Compliant Yes

Country of Origin USA