

RESIDENTIAL ROOFTOP SOLAR PERMIT PACKAGE



Kaila Myatt
 214 Young Farm Dr
 Lillington, North Carolina 27546
 9094553592



1403 N 630 E
 Orem, Utah 84097
 (800) 377-4480
 BlueRavenSolar.com

SCOPE OF WORK
 INSTALLATION OF ROOFTOP MOUNTED PHOTOVOLTAIC SOLAR SYSTEM



SHEET INDEX

- PV1 COVER SHEET
- PV2 SITE PLAN
- PV3 ROOF PLAN
- PV4 STRUCTURAL
- PV5 ELECTRICAL 3-LINE
- PV6 ELECTRICAL CALCULATIONS
- PV7 LABELS
- PV8 PLACARD
- SS SPEC SHEETS

CUSTOMER NAME: Kaila Myatt
 214 Young Farm Dr
 Lillington, North Carolina 27546

AHJ: Harnett County

UTILITY COMPANY: Duke Energy Progress

TYPICAL STRUCTURAL INFORMATION

ROOF MATERIAL: Comp Shingle
 SHEATHING: OSB
 FRAMING: Manufactured Truss
 RACKING: PEGASUS RAIL
 ROOF ATTACHMENT: PEGASUS BUTYL-FOOT
 TOTAL ATTACHMENTS: 36

NEW PV SYSTEM INFORMATION

DC SYSTEM SIZE: 6.44 kW DC
 AC SYSTEM SIZE: 5.32 kW AC
 MODULE TYPE: (14) REC Solar REC460AA Pure-RX
 INVERTER TYPE: (14) Enphase IQ8X-80-M-US

TOTAL PV DC SYSTEM SIZE
 6.440 kW DC

TOTAL PV AC SYSTEM SIZE
 5.320 kW AC

DESIGN CRITERIA

WIND SPEED: 115
 WIND EXPOSURE FACTOR: C
 RISK CATEGORY: II
 GROUND SNOW LOAD: 15
 ROOF SNOW LOAD: 10.5
 SEISMIC DESIGN CATEGORY: B

WEATHER STATION DATA

WEATHER STATION: SEYMOUR-JOHNSON AFB
 HIGH TEMP 2% AVG: 35°C
 EXTREME MINIMUM TEMP: -10°C

GENERAL NOTES

Sealed For Existing Roof & Attachment Only



11/15/24
 Firm No. : D-0449

Digitally signed by John Calvert
 Date: 2024.11.15 11:01:49 -07'00'

AHJ
 Harnett County

UTILITY COMPANY
 Duke Energy Progress

APPLICABLE CODES

*2017 NATIONAL ELECTRIC CODE (NEC)
 *2018 NORTH CAROLINA BUILDING CODE (NCBC)
 *2018 NORTH CAROLINA RESIDENTIAL CODE (NCRC), PLUMBING CODE (NPC), AND ALL STATE AND LOCAL BUILDING, ELECTRICAL, AND PLUMBING CODES

PROJECT ID: 1075499

PV DC SYSTEM SIZE: 6.440 kW DC
 PV AC SYSTEM SIZE: 5.320 kW AC

REVISIONS:

A	
B	
C	
D	

DRAWN BY: Brendan Fillmore

PLOT DATE: November 15, 2024

DRAWING TITLE: Cover Sheet

DRAWING NUMBER: PV1



1403 N 630 E
Orem, Utah 84097
(800) 377-4480
BlueRavenSolar.com

Kaila Myatt
214 Young Farm Dr
Lillington, North Carolina 27546

AHJ: Harnett County
UTILITY COMPANY: Duke Energy Progress

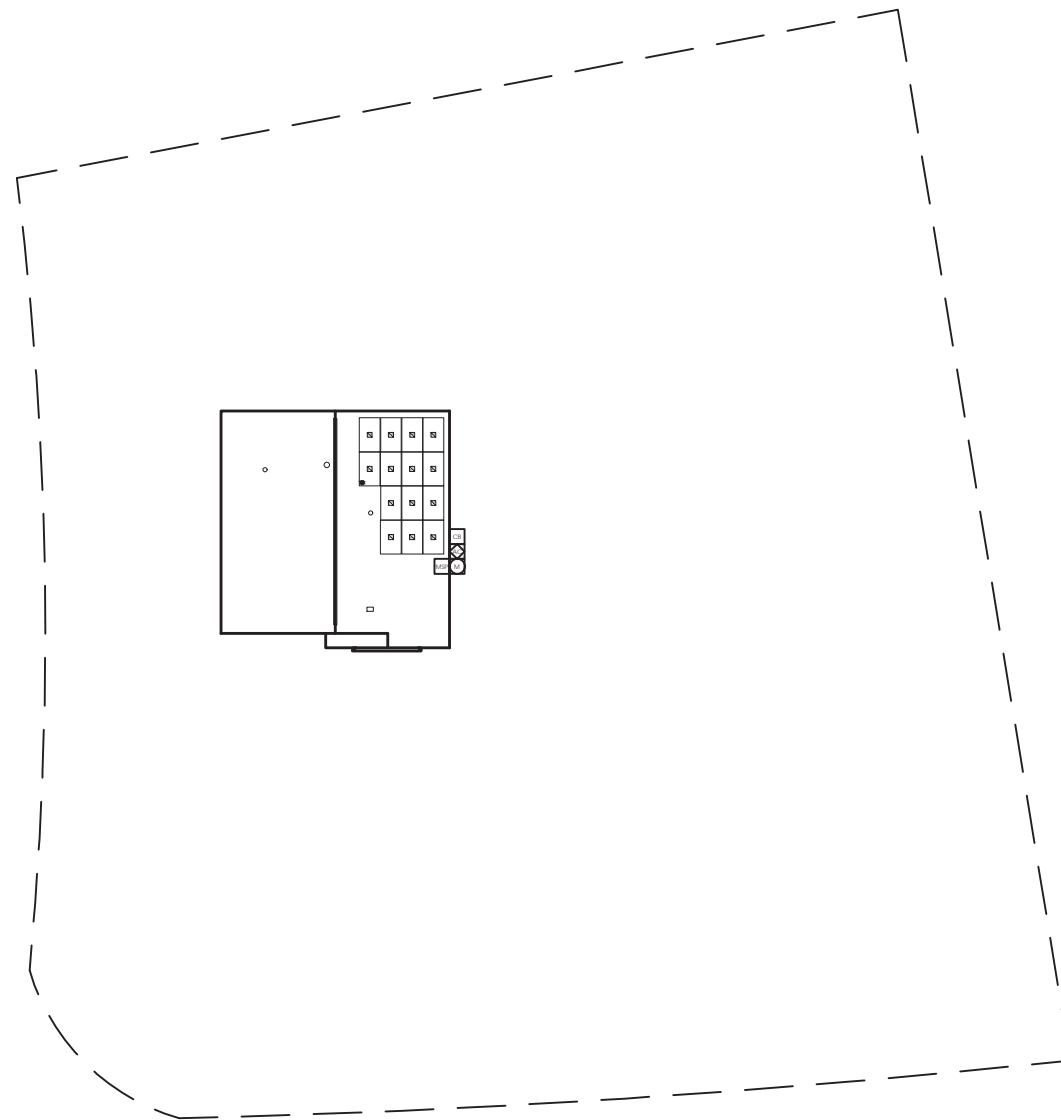

FRONT OF HOME
214 Young Farm Dr

Sealed For
Existing Roof &
Attachment Only



11/15/24
Firm No. : D-0449

PROJECT ID:
1075499

PV DC SYSTEM SIZE:
6.440 kW DC

PV AC SYSTEM SIZE:
5.320 kW AC

REVISIONS:

A	
B	
C	
D	

DRAWN BY:
Brendan Fillmore

PLOT DATE:
November 15, 2024

DRAWING TITLE:
Site Plan

DRAWING NUMBER:
PV2

SITE PLAN
SCALE: 1/32" = 1'-0"

LEGEND

UTILITY METER	BREAKER ENCLOSURE	ESS - BATTERY	FIRE SETBACK HATCH	TRENCH OR OVERHEAD
MAIN SERVICE PANEL	AC DISCONNECT	ESS - CONTROLLER	MICROINVERTER	PROPERTY LINE
SUBPANEL	PV PRODUCTION METER	REMOTE POWER OFF SWITCH	ROOF TOP JUNCTION BOX	<i>ICONS WITH DOTTED OUTLINE INDICATE INTERIOR LOCATION</i>
UTILITY METER CT CABINET	COMBINER BOX	GENERATOR ATS PANEL	INVERTER	

PV SYSTEM SPECIFICATIONS

NEW PV SYSTEM INFORMATION

PV MODULE: (14) REC Solar REC460AA Pure-RX, **POWER RATING:** 460 W
INVERTER: (14) Enphase IQ8X-80-M-US, **POWER RATING:** 380 W

COMPASS

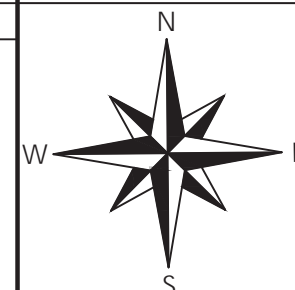

DC SYSTEM SIZE: 6.44 KW DCMODULE: REC 460INVERTER(S): Enphase IQ8X Microinverters



1403 N 630 E
Orem, Utah 84097
(800) 377-4480
BlueRavenSolar.com

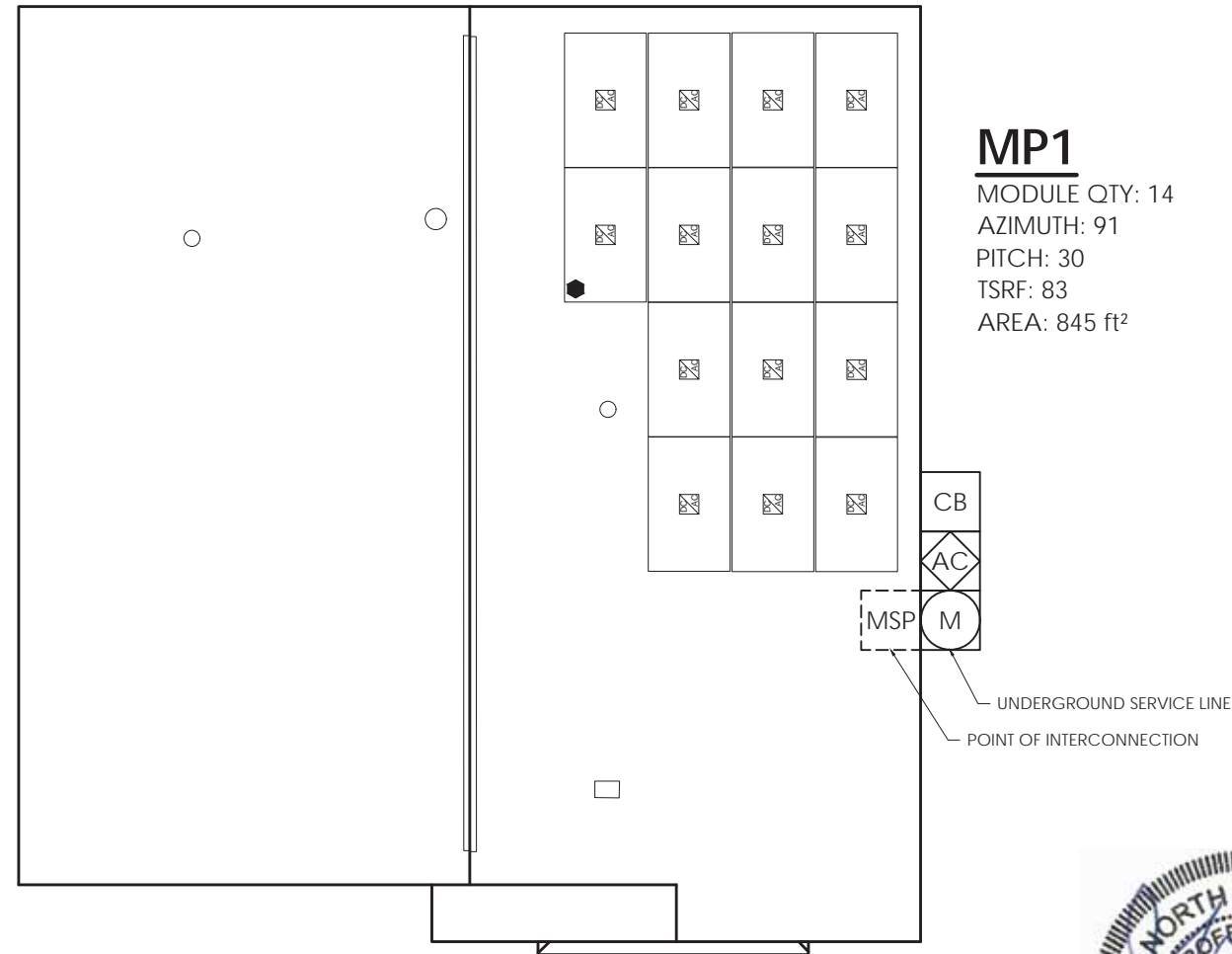

MP1
MODULE QTY: 14
AZIMUTH: 91
PITCH: 30
TSRF: 83
AREA: 845 ft²

Sealed For Existing Roof & Attachment Only



FRONT OF HOME

ROOF PLAN
SCALE: 1/8" = 1'-0"

CUSTOMER NAME: **Kaila Myatt**
214 Young Farm Dr
Lillington, North Carolina 27546
AHJ: Harnett County
UTILITY COMPANY: Duke Energy Progress

PROJECT ID: **1075499**

PV DC SYSTEM SIZE: 6.440 kW DC

PV AC SYSTEM SIZE: 5.320 kW AC

REVISIONS:

A	
B	
C	
D	

DRAWN BY: Brendan Fillmore

PLOT DATE: November 15, 2024

DRAWING TITLE: **Roof Plan**

DRAWING NUMBER: **PV3**

LEGEND

UTILITY METER	BREAKER ENCLOSURE	ESS - BATTERY	FIRE SETBACK HATCH	TRENCH OR OVERHEAD
MAIN SERVICE PANEL	AC DISCONNECT	ESS - CONTROLLER	MICROINVERTER	PROPERTY LINE
SUBPANEL	PV PRODUCTION METER	REMOTE POWER OFF SWITCH	ROOF TOP JUNCTION BOX	<i>ICONS WITH DOTTED OUTLINE INDICATE INTERIOR LOCATION</i>
UTILITY METER CT CABINET	COMBINER BOX	GENERATOR ATS PANEL	INVERTER	

PV SYSTEM SPECIFICATIONS

NEW PV SYSTEM INFORMATION
PV MODULE: (14) REC Solar REC460AA Pure-RX, **POWER RATING:** 460 W
INVERTER: (14) Enphase IQ8X-80-M-US, **POWER RATING:** 380 W

COMPASS

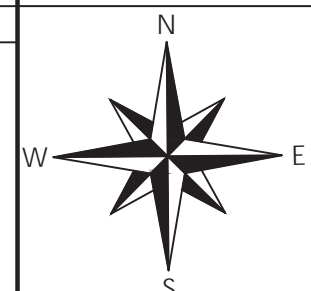

11/15/24
Firm No. : D-0449

NEW PV SYSTEM

PANEL COUNT	AZIMUTH (DEG)	PITCH (DEG)	TSRF (%)	AREA (ft²)	ROOF MATERIAL	SHEATHING TYPE	FRAMING TYPE	FRAMING SIZE AND SPACING	CEILING JOIST/PURLINS SIZE AND SPACING	RACKING TYPE	ATTACHMENT TYPE	MAXIMUM ATTACHMENT SPACING (S)	MAXIMUM CANTILEVER (C)
MP1	14	91	30	845	Comp Shingle	OSB	Manufactured Truss	2x4 @ 24 in OC	2x4 @ 24 in OC	PEGASUS RAIL	PEGASUS BUTYL-FOOT	72"L / 48"P	24"L / 16"P
MP2	0												
MP3	0												
MP4	0												
MP5	0												
MP6	0												
MP7	0												
MP8	0												
MP9	0												
MP10	0												

TOTAL PV ARRAY AREA (ft²)	313.83
TOTAL ROOF AREA (ft²)	1697.35
DISTRIBUTED LOAD (psf)	2.23
ROOF COVERAGE (%)	18.49
TOTAL PV ARRAY WEIGHT (lbs)	700
TOTAL PV ATTACHMENTS	36
POINT LOAD (lbs/att.)	19.4



1403 N 630 E
Orem, Utah 84097
(800) 377-4480
BlueRavenSolar.com

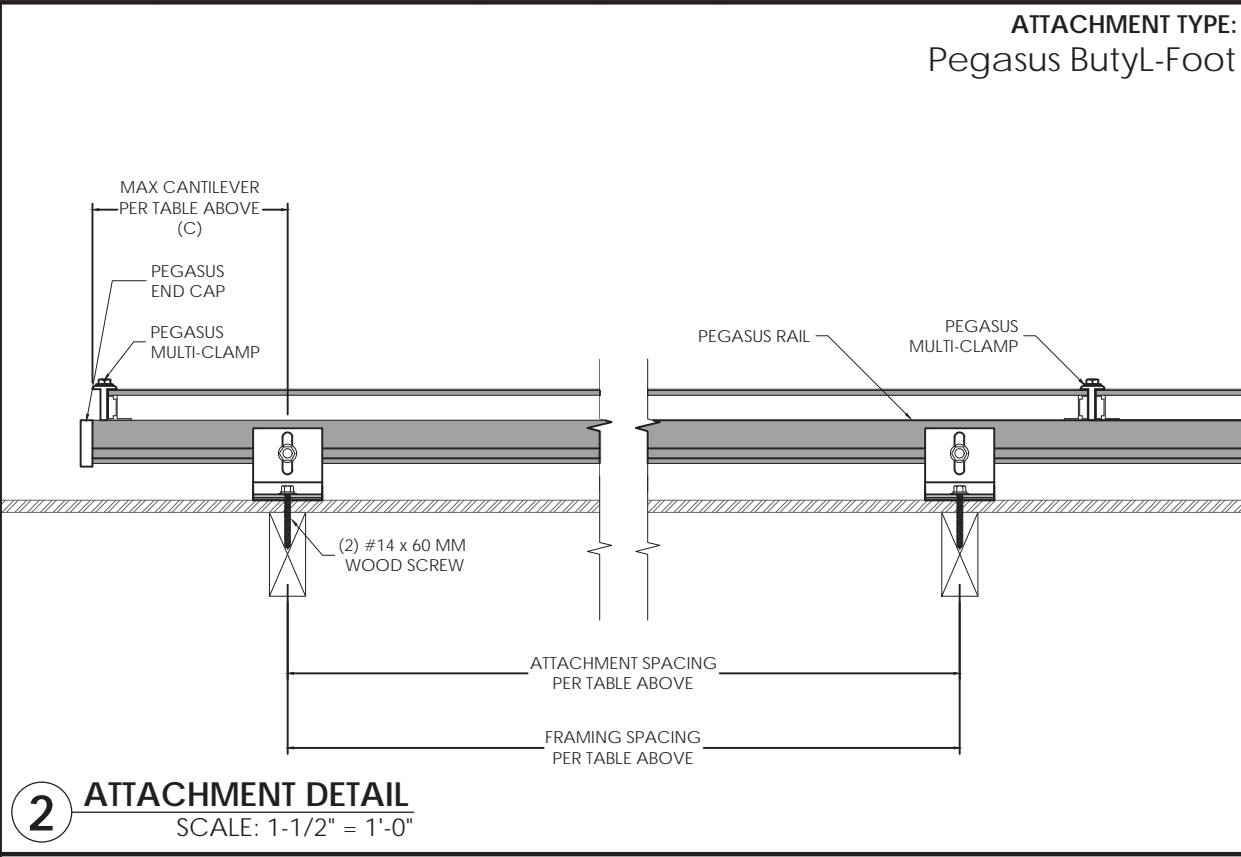
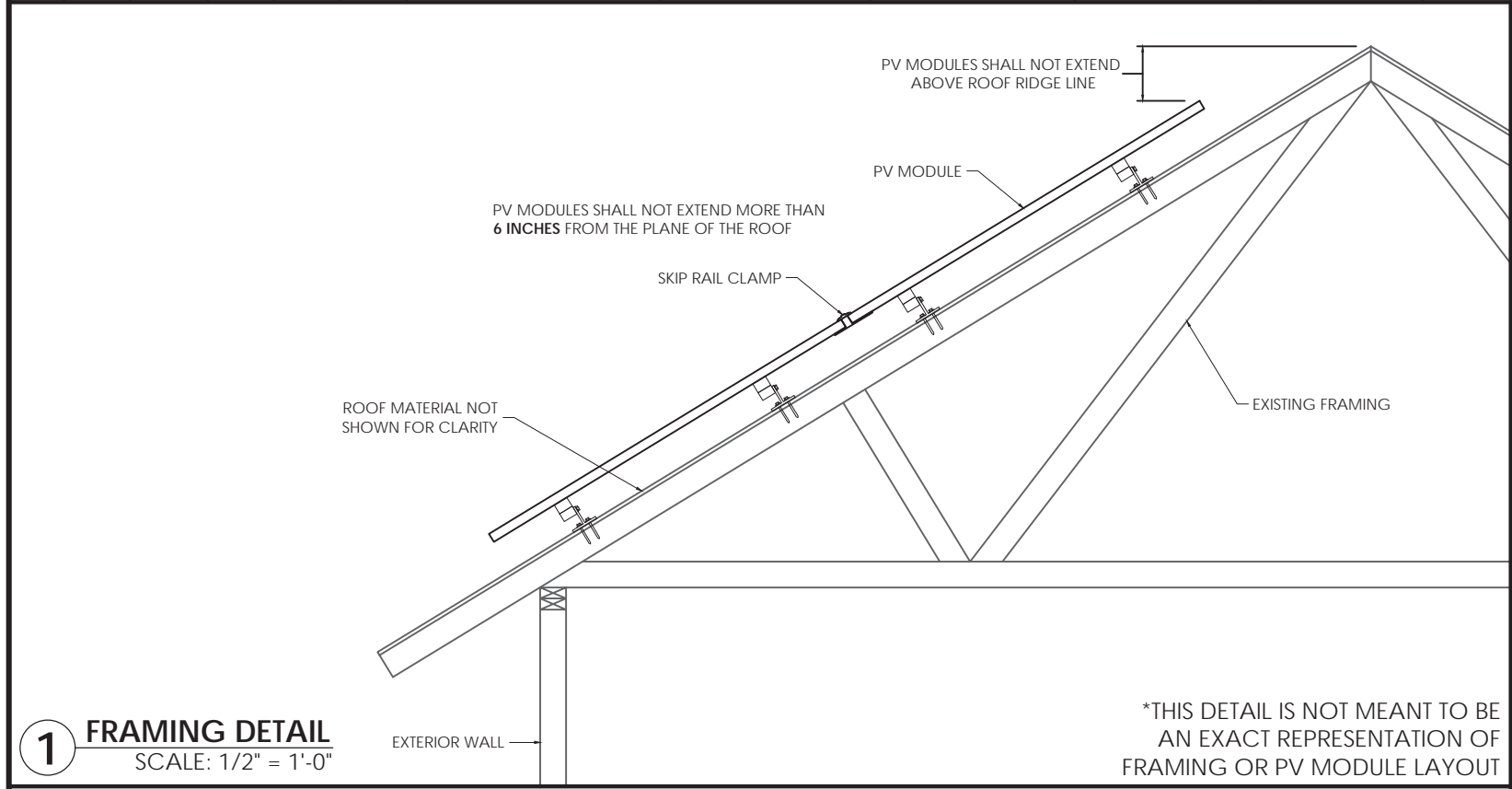

CUSTOMER NAME: **Kaila Myatt**
214 Young Farm Dr
Lillington, North Carolina 27546

AHJ: Harnett County

UTILITY COMPANY: Duke Energy Progress

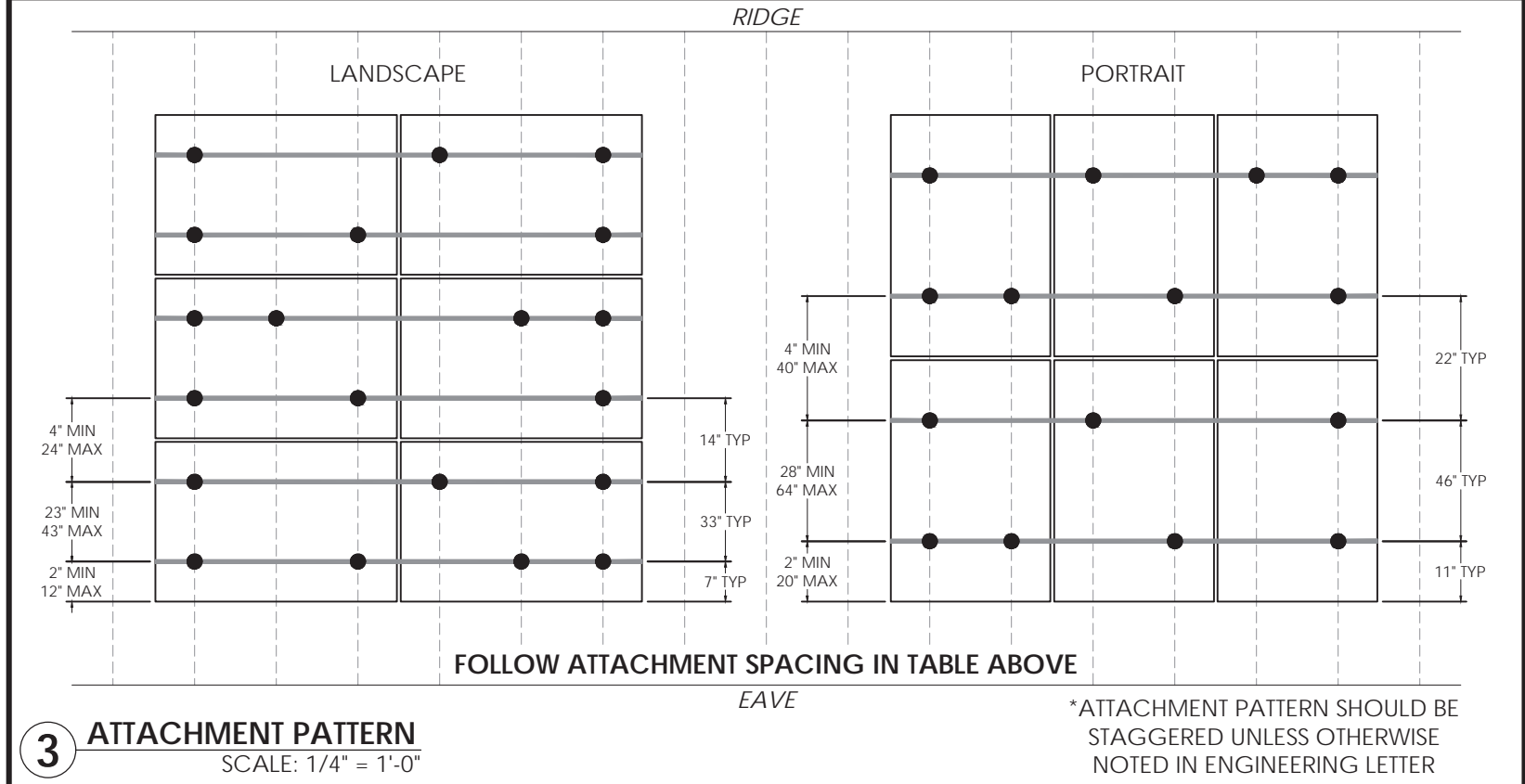

NOTES

Sealed For Existing Roof & Attachment Only

11/15/24
Firm No. : D-0449

PROJECT ID:	1075499								
PV DC SYSTEM SIZE:	6.440 kW DC								
PV AC SYSTEM SIZE:	5.320 kW AC								
REVISIONS:	<table border="1"> <tr><td>A</td><td></td></tr> <tr><td>B</td><td></td></tr> <tr><td>C</td><td></td></tr> <tr><td>D</td><td></td></tr> </table>	A		B		C		D	
A									
B									
C									
D									
DRAWN BY:	Brendan Fillmore								
PLOT DATE:	November 15, 2024								
DRAWING TITLE:	Structural								
DRAWING NUMBER:	PV4								

4	L1 (1) 10 AWG THHN/THWN-2 CU BLACK	3/4 INCH EMT	Exterior
	L2 (1) 10 AWG THHN/THWN-2 CU RED		
	N (1) 10 AWG THHN/THWN-2 CU WHITE		
	G (1) 10 AWG THHN/THWN-2 CU GREEN		

3	L1 (2) 10 AWG THHN/THWN-2 CU BLACK	3/4 INCH EMT*	*
	L2 (2) 10 AWG THHN/THWN-2 CU RED		
	G (1) 10 AWG THHN/THWN-2 CU GREEN		

2	L1 (1) 10 AWG THHN/THWN-2 CU BLACK	3/4 INCH	*
	L2 (1) 10 AWG THHN/THWN-2 CU RED		
	G (1) 10 AWG THHN/THWN-2 CU GREEN		

1	L1 (1) 12 AWG THHN/THWN-2 CU BLACK	ENPHASE O-CABLE, 2-WIRE, FREE AIR	Exterior
	L2 (1) 12 AWG THHN/THWN-2 CU RED		
	G (1) 6 AWG BARE, CU		

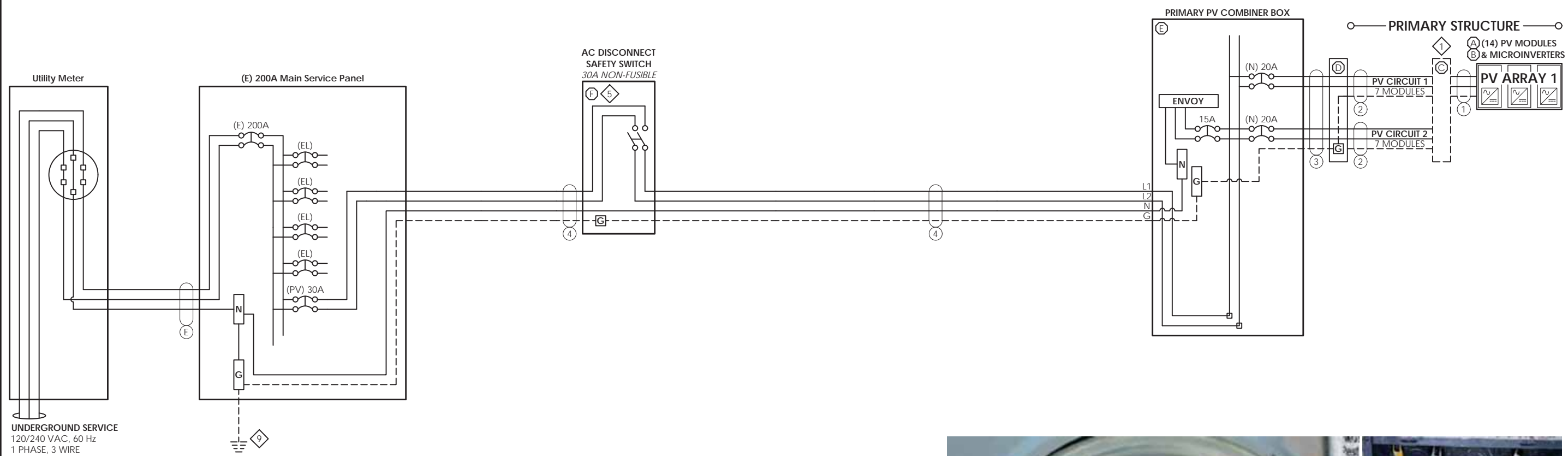

INTERCONNECTION NOTES

Utility Meter Number: 338453985

Load side breaker in MSP. Interior POI.

LEGEND

(E) EXISTING	(PV) PV BREAKER
(N) NEW	(FIB) FACTORY INSTALLED BREAKER
(EL) EXISTING LOADS	SPD SURGE PROTECTIVE DEVICE
(RL) RELOCATED LOADS	MI MECHANICAL INTERLOCK

EQUIPMENT NOTES

1 FINAL CONFIGURATION OF PV CIRCUITS TO BE DECIDED BY INSTALLER. MUST COMPLY WITH MAX MICROINVERTERS PER CIRCUIT AS LISTED ON ATTACHED SPEC SHEET.

2

3

4

5

6

7

8

9 GROUNDING ELECTRODE SYSTEM SHALL BE IN ACCORDANCE WITH NEC 250.53.

10

11

12

EQUIPMENT DESCRIPTIONS

(A) PV MODULE: REC Solar REC460AA Pure-RX, 460 W DC, UL 1703 / UL 61730 COMPLIANT

(B) MICROINVERTER: ENPHASE IQ8X-80-M-US, 380 W AC (0.380 kW), 1 PHASE, UL 1741 COMPLIANT

(C) ROOFTOP JUNCTION BOX: EZ SOLAR JB-1.2 JUNCTION BOX

(D) JUNCTION BOX: PVC 4 X 4 JUNCTION BOX

(E) PV COMBINER BOX: ENPHASE COMBINER 5 (X-IQ-AM1-240-5)

(F) SQUARE-D SAFETY SWITCH 30A, 2P, 240VAC, NON-FUSIBLE (DU221RB)

(G)

(H)

(I)

(J)

(K)

(L)

(M)

(N)

(O)

(P)

(Q)

(R)

(S)

(T)

(U)

(V)

(W)

(X)

(Y)

(Z)

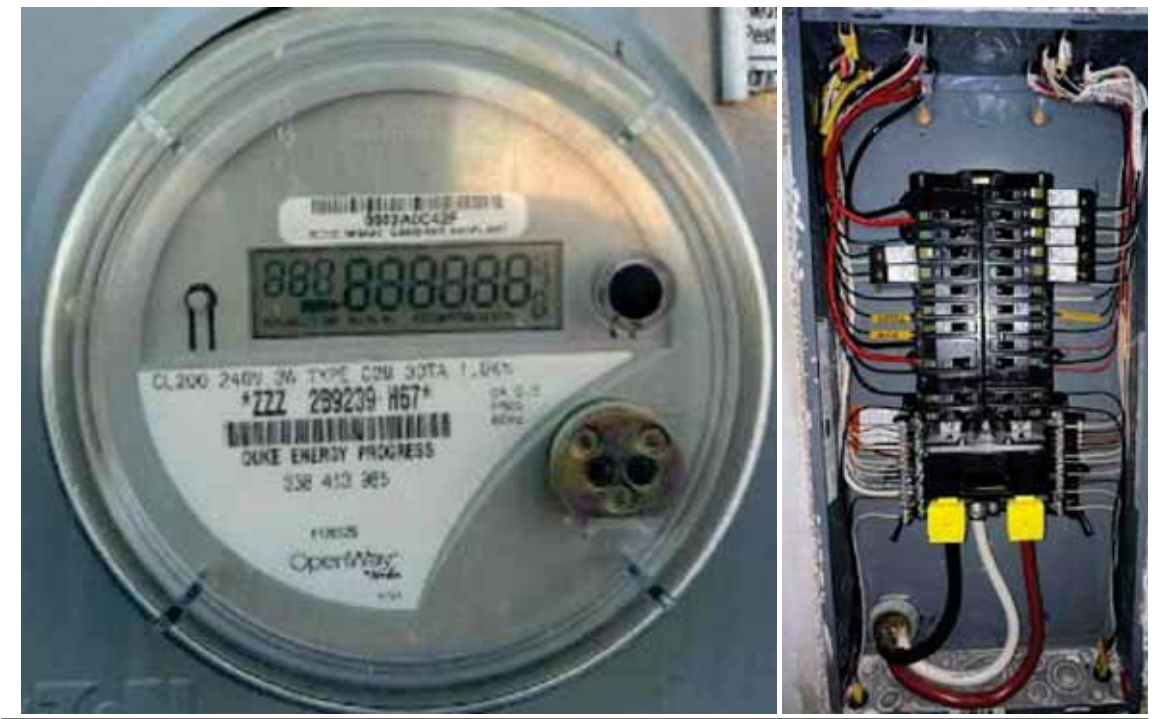

OTHER NOTES

14 MICROINVERTERS X 380 W AC = 5.32 KW AC; PANEL WATTAGE = 460 W DC



1403 N 630 E
Orem, Utah 84097
(800) 377-4480
BlueRavenSolar.com

CUSTOMER NAME: Kaila Myatt
214 Young Farm Dr
Lillington, North Carolina 27546

AHI: Harnett County

UTILITY COMPANY: Duke Energy Progress

PROJECT ID: 1075499

PV DC SYSTEM SIZE: 6.440 kW DC

PV AC SYSTEM SIZE: 5.320 kW AC

REVISIONS:

A	
B	
C	
D	

DRAWN BY: Brendan Fillmore

PLOT DATE: November 15, 2024

DRAWING TITLE: Electrical 3-Line

DRAWING NUMBER: PV5

ELECTRICAL INFORMATION	
UTILITY ELECTRICAL SYSTEM	
1-Phase, 3-Wire, 60Hz, 120/240V	
NEW PV SYSTEM	
1-Phase, 3-Wire, 60Hz, 120/240V	
AC SYSTEM SIZE	5.32kW AC
DC SYSTEM SIZE	6.44kW DC
PV MODULES	
QUANTITY	14
TYPE	REC Solar REC460AA Pure-RX
WATTAGE	460W DC
MICROINVERTERS	
TYPE	Enphase IQ8X-80-M-US
OUTPUT CURRENT	1.58A AC
NOMINAL VOLTAGE	240V AC
OUTPUT POWER	380W AC

PV BREAKER BACKFEED CALCULATIONS			
NEC 705.12(B) -- "120% RULE"			
(BUSBAR RATING * 120%) - OCPD RATING = AVAILABLE BACKFEED			
	MAIN SERVICE PANEL	SUBPANEL 1	SUBPANEL 2
BUSBAR RATING	200A	---A	---A
PANEL OCPD RATING	200A	---A	---A
AVAILABLE BACKFEED (120% RULE)	40A	##A	##A
PV BREAKER RATING	30A	30A	30A
<i>*THESE CALCULATIONS ARE ONLY APPLICABLE IF PV INTERCONNECTION IS A LOAD SIDE BREAKER. *PV BREAKER MUST BE RATED LESS THAN OR EQUAL TO AVAILABLE BACKFEED FOR CODE COMPLIANCE*</i>			

DESIGN LOCATION AND TEMPERATURES	
DATA SOURCE	ASHRAE Weather Station Data
STATE	North Carolina
CITY	Lillington
WEATHER STATION	SEYMOUR-JOHNSON AFB
HIGH TEMP 2% AVG	35°C
EXTREME MINIMUM TEMP	-10°C

WIRE SIZE SPECIFICATIONS										
	①	②	③	④	⑤	⑥	⑦	⑧	⑨	⑩
MINIMUM CONDUCTOR AMPACITY	13.83A AC	13.83A AC	13.83A AC	27.65A AC	---A AC	---A AC	---A AC	---A AC	---A AC	---A AC
CONDUCTOR MATERIAL	CU	CU	CU	CU	---	---	---	---	---	---
CONDUCTOR TYPE	THHN/THWN-2	THHN/THWN-2	THHN/THWN-2	THHN/THWN-2	---	---	---	---	---	---
CONDUCTOR SIZE	12 AWG	10 AWG	10 AWG	10 AWG	---	---	---	---	---	---
CONDUCTOR AMPACITY	30A	40A	40A	40A	---A	---A	---A	---A	---A	---A
AMBIENT TEMPERATURE ADJUSTMENT FACTOR	0.96	0.96	0.96	0.96	---	---	---	---	---	---
CONDUIT FILL ADJUSTMENT FACTOR	1	1	0.8	1	---	---	---	---	---	---
ADJUSTED CONDUCTOR AMPACITY	28.8A	38.4A	30.72A	38.4A	---A	---A	---A	---A	---A	---A
WIRE RUN DISTANCE (FT)	46	40	20	5	---	---	---	---	---	---
CALCULATED VOLTAGE DROP	0.48%	0.46%	0.23%	0.11%	0%	0%	0%	0%	0%	0%

PV CIRCUIT SPECIFICATIONS													
	PRIMARY STRUCTURE								DETACHED STRUCTURE				
	CIRCUIT 1	CIRCUIT 2	CIRCUIT 3	CIRCUIT 4	CIRCUIT 5	CIRCUIT 6	CIRCUIT 7	CIRCUIT 8	CIRCUIT 1	CIRCUIT 2	CIRCUIT 3	CIRCUIT 4	CIRCUIT 5
NUMBER OF MODULES PER CIRCUIT	7	7	0	0	0	0	0	0	0	0	0	0	0
RATED AC OUTPUT CURRENT (I _{out})	11.1A	11.1A	0.0A	0.0A	0.0A	0.0A	0.0A	0.0A	0.0A	0.0A	0.0A	0.0A	0.0A
MINIMUM AMPACITY (I _{out} x 125%)	13.8A	13.8A	0.0A	0.0A	0.0A	0.0A	0.0A	0.0A	0.0A	0.0A	0.0A	0.0A	0.0A
OVERCURRENT PROTECTION RATING	20A	20A	20A	20A	20A	20A	20A	20A	20A	20A	20A	20A	20A
COMBINED AC OUTPUT CURRENT (C _{out})	22.1A								0.0A				
MINIMUM AMPACITY (C _{out} x 125%)	27.7A								0.0A				
COMBINED PV BREAKER RATING	30AA								0AA				

TOTAL VOLTAGE DROP	
WIRE TAG	VOLTAGE DROP
WIRE TAG #1	0.48%
WIRE TAG #2	0.46%
WIRE TAG #3	0.23%
WIRE TAG #4	0.11%
WIRE TAG #5	0%
WIRE TAG #6	0%
TOTAL	1.280000%



1403 N 630 E
Orem, Utah 84097
(800) 377-4480
BlueRavenSolar.com

Kaila Myatt
214 Young Farm Dr
Lillington, North Carolina 27546

AHJ: Harnett County
UTILITY COMPANY: Duke Energy Progress

CUSTOMER NAME:

PROJECT ID:

1075499

PV DC SYSTEM SIZE:
6.440 kW DC

PV AC SYSTEM SIZE:
5.320 kW AC

REVISIONS:

A
B
C
D

DRAWN BY:
Brendan Fillmore

PLOT DATE:
November 15, 2024

DRAWING TITLE:
Electrical Calculations

DRAWING NUMBER:

PV6

WARNING LABELS

UTILITY METER

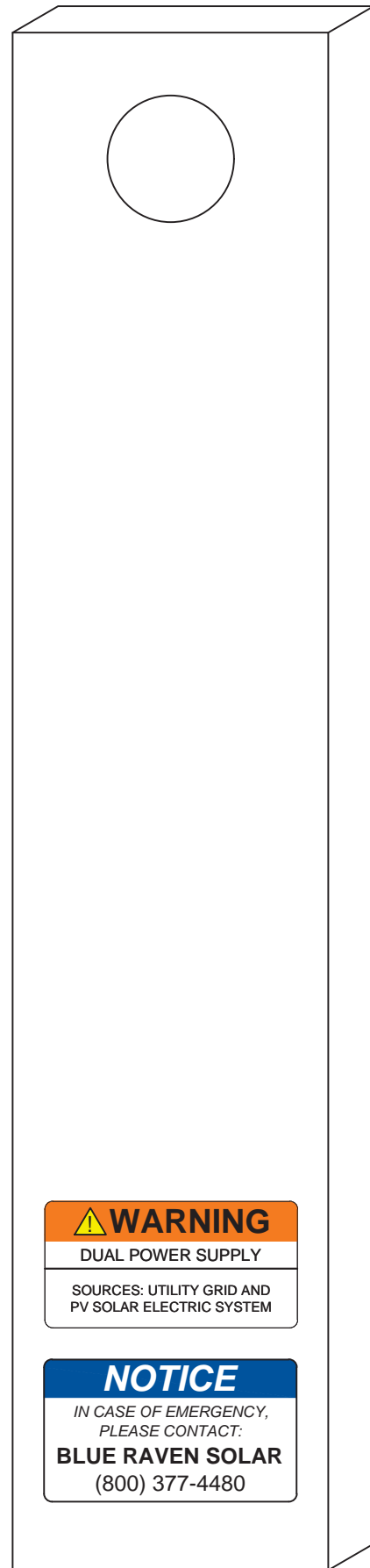

MAIN SERVICE PANEL

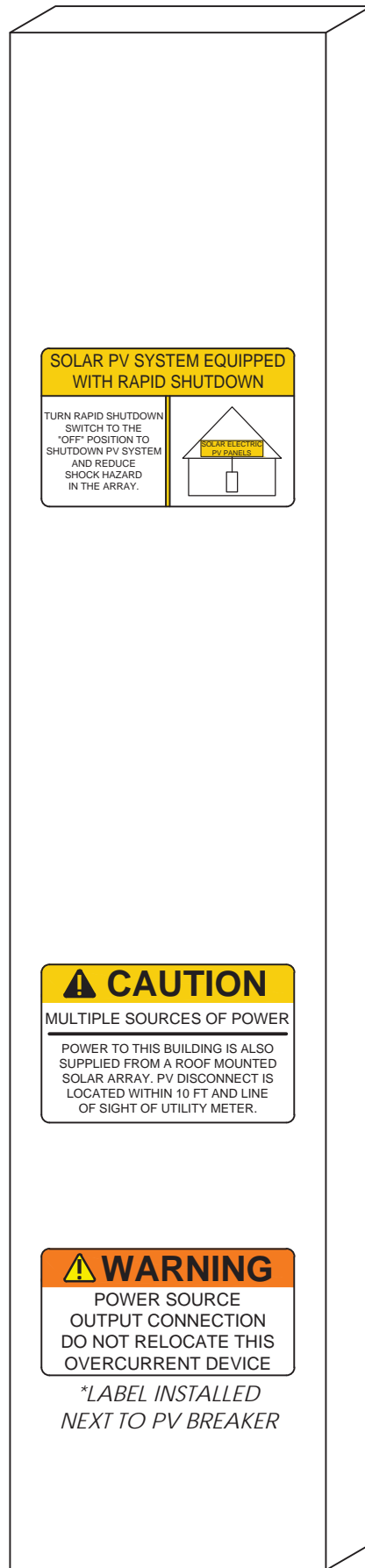

PV AC DISCONNECT

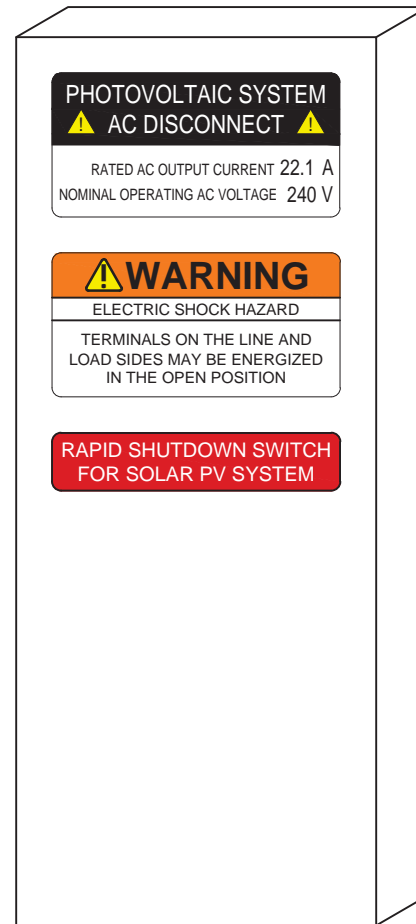

PV COMBINER BOX



1403 N 630 E
Orem, Utah 84097
(800) 377-4480
BlueRavenSolar.com

Customer Name: Kaila Myatt
214 Young Farm Dr
Lillington, North Carolina 27546

AHJ: Harnett County

Utility Company: Duke Energy Progress

PROJECT ID: 1075499

PV DC SYSTEM SIZE: 6.440 kW DC

PV AC SYSTEM SIZE: 5.320 kW AC

REVISIONS:

A	
B	
C	
D	

DRAWN BY: Brendan Fillmore

PLOT DATE: November 15, 2024

DRAWING TITLE: Warning Labels

DRAWING NUMBER: PV7

SOLAR'S MOST TRUSTED



REC ALPHA[®] PURE-RX SERIES

DATASHEET

470 W_P
22.6% EFFICIENCY
226 W/M²



9 A MODULE CURRENT
COMPATIBLE WITH MLPE



EXPERIENCE



PERFORMANCE

REC ALPHA[®] PURE-RX SERIES DATASHEET



GENERAL DATA	
Cell Type	88 half-cut bifacial REC heterojunction cells, with gapless technology
Glass	3.2 mm solar glass with anti-reflective surface treatment in accordance with EN12150
Backsheet	Highly resistant polymer (Black)
Frame	Anodized aluminum (Black)
Junction Box	4-part, 4 bypass diodes, IP68 rated, in accordance with IEC 62790
Connectors	Stäubli MC4 PV-KBT4/KST4 (4 mm ²) in accordance with IEC 62852, IP68 only when connected
Cable	4 mm ² solar cable, 1.7 m + 1.7 m in accordance with EN50618
Dimensions	1728 x 1205 x 30 mm (2.08 m ²)
Weight	22.7 kg
Origin	Made in Singapore

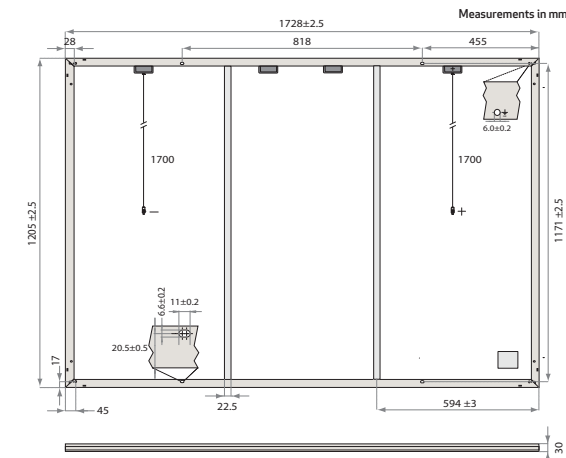

ELECTRICAL DATA		PRODUCT CODE*: RECxxxAA Pure-RX		
STC	Power Output - P _{MAX} (W _p)	450	460	470
	Watt Class Sorting - (W)	0/+10	0/ .0	0/+10
	Nominal Power Voltage - V _{MPP} (V)	54.3	54.9	55.4
	Nominal Power Current - I _{MPP} (A)	8.29	8.38	8.49
	Open Circuit Voltage - V _{OC} (V)	65.1	65.3	65.6
	Short Circuit Current - I _{SC} (A)	8.81	8.88	8.95
	Power Density (W/m ²)	216	221	226
	Panel Efficiency (%)	21.6	22.1	22.6
NMOT	Power Output - P _{MAX} (W _p)	343	350	358
	Nominal Power Voltage - V _{MPP} (V)	51.2	51.7	52.2
	Nominal Power Current - I _{MPP} (A)	6.70	6.77	6.86
	Open Circuit Voltage - V _{OC} (V)	61.3	61.6	61.8
	Short Circuit Current - I _{SC} (A)	7.11	7.17	7.23

Values at standard test conditions (STC: air mass AM 1.5, irradiance 1000 W/m², temperature 25°C), based on a production spread with a tolerance of P_{max}, V_{oc} & I_{sc} ±3% within one watt class. Nominal module operating temperature (NMOT: air mass AM 1.5, irradiance 800 W/m², temperature 20°C, windspeed 1 m/s). * Where xxx indicates the nominal power class (P_{max}) at STC above.

MAXIMUM RATINGS*	
Operational Temperature	-40 °C - 85 °C
System Voltage	1000 V
Maximum Test Load (front)	+7000 Pa (713 kg/m ²)
Maximum Test Load (rear)	-4000 Pa (407 kg/m ²)
Max Series Fuse Rating	25 A
Max Reverse Current	25 A

TEMPERATURE RATINGS*	
Nominal Module Operating Temperature	44 °C ± 2°C
Temperature coefficient of P _{MAX}	-0.24% / °C
Temperature coefficient of V _{OC}	-0.24% / °C
Temperature coefficient of I _{SC}	0.04% / °C

DELIVERY INFORMATION	
Panels per Pallet	33
Panels per 40 ft GP/high cube container	594 (18 Pallets)
Panels per 13.6 m truck	660 (20 Pallets)

Available from:

Founded in 1996, REC Group is an international pioneering solar energy company dedicated to empowering consumers with clean, affordable solar power. As Solar's Most Trusted, REC is committed to high quality, innovation, and a low carbon footprint in the solar materials and solar panels it manufactures. Headquartered in Norway with operational headquarters in Singapore, REC also has regional hubs in North America, Europe, and Asia-Pacific.

CERTIFICATIONS	
IEC 61215:2011; IEC61730:2016; UL61730	
ISO 11925-2 Ignitability (EN 13501-1 Class E)	
IEC 62716 Ammonia Resistance	
IEC 61701 Salt Mist (SM6)	
IEC 61215:2016 Hailstone (35 mm)	
UL 61730 Fire Type 2	
ISO 14001; ISO9001; IEC45001; IEC62941	



WARRANTY			
	Standard	REC ProTrust	
Installed by an REC Certified Professional	No	Yes	Yes
System Size	All	<25 kW	25-500 kW
Product Warranty (yrs)	20	25	25
Power Warranty (yrs)	25	25	25
Labor Warranty (yrs)	0	25	10
Power in Year 1	98%	98%	98%
Annual Degradation	0.25%	0.25%	0.25%
Power in Year 25	92%	92%	92%

The REC ProTrust Warranty is only available on panels purchased through an REC Certified Solar Professional installer. Warranty conditions apply. See www.recgroup.com for more details

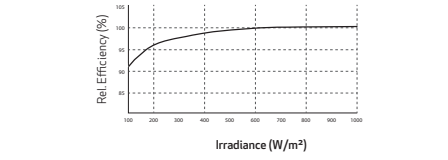

REC Solar PTE. LTD.
20 Tuas South Ave. 14
Singapore 637312
post@recgroup.com
www.recgroup.com



Specifications subject to change without notice.

Ref: PM-DS-12-06-Rev-4.45.2024

DRAWING NUMBER:
SS

IQ8X Microinverter



IQ8X Microinverter

Our newest IQ8 Series Microinverters are the industry's first microgrid-forming*, software-defined microinverters with split-phase power conversion capability to convert DC power to AC power efficiently. The brain of the semiconductor-based microinverter is our proprietary application-specific integrated circuit (ASIC), which enables the microinverter to operate in grid-tied or off-grid mode. This chip is built using advanced 55-nm technology with high-speed digital logic and superfast response times to changing loads and grid events, alleviating constraints on battery sizing for home energy systems.

IQ8X Microinverter is the latest addition to this family, designed to support PV modules with high input DC voltage and cell counts, such as 80-half-cut cells, 88-half-cut cells and 96-cells.



Part of the Enphase Energy System, IQ8 Series Microinverters integrate with the IQ Battery, IQ Gateway, and the Enphase App monitoring and analysis software.



IQ8 Series Microinverters redefine reliability standards with more than one million cumulative hours of power-on testing, enabling an industry-leading limited warranty of up to 25 years.

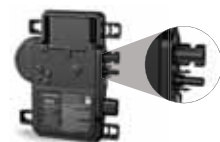

Connect PV modules quickly and easily to the IQ8 Series Microinverters with integrated MC4 connectors.



IQ8 Series Microinverters are UL Listed as PV rapid shutdown equipment and conform with regulations when installed according to the manufacturer's instructions.

*Meets UL 1741 only when installed with IQ System Controller 2 and 3.

Easy to install

- Lightweight and compact with plug-and-play connectors
- Power line communication (PLC) between components
- Faster installation with simple two-wire cabling

High productivity and reliability

- Produces power even when the grid is down*
- More than one million cumulative hours of testing
- Class II double-insulated enclosure
- Optimized for the latest high-powered PV modules

Microgrid-forming

- Complies with the latest advanced grid support
- Remote automatic updates for the latest grid requirements
- Configurable to support a wide range of grid profiles
- Meets CA Rule 21 (UL 1741-SA) and IEEE 1547:2018 (UL 1741-SB)

NOTE:

- IQ8 Series Microinverters cannot be mixed with previous generations of Enphase microinverters (IQ7 Series, IQ6 Series, and so on) in the same system.
- IQ Gateway is required to change the default grid profile at the time of installation to meet local Authority Having Jurisdiction (AHJ) requirements.

INPUT DATA (DC)	UNIT	IQ8X-80-M-US
Commonly used module pairings ¹	W	320-540
Module compatibility	—	To meet compatibility, PV modules must be within the following maximum input DC voltage and maximum module I _{sc} . Module compatibility can be checked at https://enphase.com/installers/microinverters/calculator
MPPT voltage range	V	43-60
Operating range	V	25-79.5
Minimum and maximum start voltage	V	30-79.5
Maximum input DC voltage	V	79.5
Maximum continuous operating DC current	A	10
Maximum input DC short-circuit current	A	16
Maximum module I _{sc}	A	13
Overvoltage class DC port	—	II
DC port backfeed current	mA	0
PV array configuration	—	Ungrounded array; no additional DC side protection required; AC side protection requires maximum 20 A per branch circuit

OUTPUT DATA (AC)	UNIT	IQ8X-80-M-US @240 VAC	IQ8X-80-M-US @208 VAC
Peak output power	VA	384	366
Maximum continuous output power	VA	380	360
Nominal grid voltage (L-L)	V	240, split-phase (L-L), 180°	208, single-phase (L-L), 120° ⁴
Minimum and maximum grid voltage ²	V	211-264	183-229
Max. continuous output current	A	1.58	1.73
Nominal frequency	Hz	60	
Extended frequency range	Hz	47-68	
AC short circuit fault current over three cycles	A _{rms}	2.70	
Maximum units per 20 A (L-L) branch circuit ³	—	10	9
Total harmonic distortion	%	<5	
Overvoltage class AC port	—	III	
AC port backfeed current	mA	18	
Power factor setting	—	1.0	
Grid-tied power factor (adjustable)	—	0.85 leading ... 0.85 lagging	
Peak efficiency	%	97.3	97.0
CEC weighted efficiency	%	96.5	96.5
Nighttime power consumption	mW	26	12

MECHANICAL DATA	
Ambient temperature range	-40°C to 65°C (-40°F to 149°F)
Relative humidity range	4% to 100% (condensing)
DC connector type	Stäubli MC4
Dimensions (H × W × D); Weight	212 mm (8.3") × 175 mm (6.9") × 30.2 mm (1.2"); 1.1 kg (2.43 lbs)
Cooling	Natural convection - no fans
Approved for wet locations; Pollution degree	Yes; PD3
Enclosure	Class II double-insulated, corrosion-resistant polymeric enclosure
Environmental category; UV exposure rating	NEMA Type 6; outdoor

COMPLIANCE	
Certifications	CA Rule 21 (UL 1741-SA), UL 62109-1, IEEE 1547:2018 (UL 1741-SB), FCC Part 15 Class B, ICES-0003 Class B, CAN/CSA-C22.2 NO. 1071-01 This product is UL Listed as PV rapid shutdown equipment and conforms with NEC 2014, NEC 2017, NEC 2020, and NEC 2023 section 690.12 and C22.1-2018 Rule 64-218 rapid shutdown of PV systems for AC and DC conductors when installed according to the manufacturer's instructions.

(1) No enforced DC/AC ratio.
 (2) Nominal voltage range can be extended beyond nominal if required by the utility.
 (3) Limits may vary. Refer to local requirements to define the number of microinverters per branch in your area.
 (4) IQ8X is not certified for use with Enphase Three Phase Network Protection Relay (NPR-3P-208-NA) and therefore designed for single-phase operation only. Check with the local utility requirements if you wish to install single phase inverter across three phases.

Enphase Q Cable Accessories

The **Enphase Q Cable™** and accessories are part of the latest generation Enphase IQ System™. These accessories provide simplicity, reliability, and faster installation times.

Enphase Q Cable

- Two-wire, double-insulated Enphase Q Cable is 50% lighter than the previous generation Enphase cable
- New cable numbering and plug and play connectors speed up installation and simplify wire management
- Link connectors eliminate cable waste

Field-Wireable Connectors

- Easily connect Q cables on the roof without complex wiring
- Make connections from any open connector and center feed any section of cable within branch limits
- Available in male and female connector types

Enphase Q Cable Accessories

CONDUCTOR SPECIFICATIONS

Certification	UL3003 (raw cable), UL 9703 (cable assemblies), DG cable
Flame test rating	FT4
Compliance	RoHS, OIL RES I, CE, UV Resistant, combined UL for Canada and United States
Conductor type	THHN/THWN-2 dry/wet
Disconnecting means	The AC and DC bulkhead connectors have been evaluated and approved by UL for use as the load-break disconnect required by NEC 690.





Q CABLE TYPES / ORDERING OPTIONS

Connectorized Models	Size / Max Nominal Voltage	Connector Spacing	PV Module Orientation	Connector Count per Box
Q-12-10-240	12 AWG / 277 VAC	1.3 m (4.2 ft)	Portrait	240
Q-12-17-240	12 AWG / 277 VAC	2.0 m (6.5 ft)	Landscape (60-cell)	240
Q-12-20-200	12 AWG / 277 VAC	2.3 m (7.5 ft)	Landscape (72-cell)	200

ENPHASE Q CABLE ACCESSORIES

Name	Model Number	Description
Raw Q Cable	Q-12-RAW-300	300 meters of 12 AWG cable with no connectors
Field-wireable connector (male)	Q-CONN-10M	Make connections from any open connector
Field-wireable connector (female)	Q-CONN-10F	Make connections from any Q Cable open connector
Cable Clip	Q-CLIP-100	Used to fasten cabling to the racking or to secure looped cabling
Disconnect tool	Q-DISC-10	Disconnect tool for Q Cable connectors, DC connectors, and AC module mount
Q Cable sealing caps (female)	Q-SEAL-10	One needed to cover each unused connector on the cabling
Terminator	Q-TERM-10	Terminator cap for unused cable ends
Enphase EN4 to MC4 adaptor ¹	ECA-EN4-S22	Connect PV module using MC4 connectors to IQ micros with EN4 (TE PV4-S SOLARLOK). 150mm/5.9" to MC4.
Enphase EN4 non-terminated adaptor ¹	ECA-EN4-FW	For field wiring of UL certified DC connectors. EN4 (TE PV4-S SOLARLOK) to non-terminated cable. 150mm/5.9"
Enphase EN4 to MC4 adaptor (long) ¹	ECA-EN4-S22-L	Longer adapter cable for EN4 (TE PV4-S SOLARLOK) to MC4. Use with split cell modules or PV modules with short DC cable. 600mm/23.6"
Replacement DC Adaptor (MC4)	Q-DCC-2	DC adaptor to MC4 (max voltage 100 VDC)
Replacement DC Adaptor (UTX)	Q-DCC-5	DC adaptor to UTX (max voltage 100 VDC)

1. Qualified per UL subject 9703.

	TERMINATOR Terminator cap for unused cable ends, sold in packs of ten (Q-TERM-10)		SEALING CAPS Sealing caps for unused aggregator and cable connections (Q-BA-CAP-10 and Q-SEAL-10)
	DISCONNECT TOOL Plan to use at least one per installation, sold in packs of ten (Q-DISC-10)		CABLE CLIP Used to fasten cabling to the racking or to secure looped cabling, sold in packs of one hundred (Q-CLIP-100)



X-IQ-AM1-240-5
X-IQ-AM1-240-5C

IQ Combiner 5/5C

The IQ Combiner 5/5C consolidates interconnection equipment into a single enclosure and streamlines IQ Series Microinverters and IQ Gateway installation by providing a consistent, pre-wired solution for residential applications. IQ Combiner 5/5C uses wired control communication and is compatible with IQ System Controller 3/3G and IQ Battery 5P.

The IQ Combiner 5/5C, IQ Series Microinverters, IQ System Controller 3/3G, and IQ Battery 5P provide a complete grid-agnostic Enphase Energy System.



IQ Series Microinverters
The high-powered smart grid-ready IQ Series Microinverters (IQ6, IQ7, and IQ8 Series) simplify the installation process.



IQ System Controller 3/3G
Provides microgrid interconnection device (MID) functionality by automatically detecting grid failures and seamlessly transitioning the home energy system from grid power to backup power.



IQ Battery 5P
Fully integrated AC battery system. Includes six field-replaceable IQ8D-BAT Microinverters.



IQ Load Controller
Helps prioritize essential appliances during a grid outage to optimize energy consumption and prolong battery life.





5-year limited warranty

*For country-specific warranty information, see the <https://enphase.com/installers/resources/warranty> page.

© 2024 Enphase Energy. All rights reserved. Enphase, the e and CC logos, IQ, and certain other marks listed at <https://enphase.com/trademark-usage-guidelines> are trademarks of Enphase Energy, Inc. in the U.S. and other countries. Data subject to change.

Smart

- Includes IQ Gateway for communication and control
- Includes Enphase Mobile Connect (CELLMODEM-M1-06-SP-05), only with IQ Combiner 5C
- Supports flexible networking: Wi-Fi, Ethernet, or cellular
- Provides production metering (revenue grade) and consumption monitoring

Easy to install

- Mounts to one stud with centered brackets
- Supports bottom, back, and side conduit entries
- Supports up to four 2-pole branch circuits for 240 VAC plug-in breakers (not included)
- 80 A total PV branch circuits
- Bluetooth-based Wi-Fi provisioning for easy Wi-Fi setup

Reliable

- Durable NRTL-certified NEMA type 3R enclosure
- 5-year limited warranty
- 2-year labor reimbursement program coverage included for both the IQ Combiner SKUs¹
- UL1741 Listed

IQ Combiner 5/5C

MODEL NUMBER	
IQ Combiner 5 (X-IQ-AM1-240-5)	IQ Combiner 5 with IQ Gateway printed circuit board for integrated revenue-grade PV production metering (ANSIC12.20 ±0.5%), consumption monitoring (± 2.5%), and IQ Battery monitoring (±2.5%). Includes a silver solar shield to deflect heat.
IQ Combiner 5C (X-IQ-AM1-240-5C)	IQ Combiner 5C with IQ Gateway printed circuit board for integrated revenue-grade PV production metering (ANSI C12.20 ±0.5%), consumption monitoring (±2.5%) and IQ Battery monitoring (±2.5%). Includes Enphase Mobile Connect cellular modem (CELLMODEM-M1-06-SP-05) ¹ . Includes a silver solar shield to deflect heat.

WHAT'S IN THE BOX	
IQ Gateway printed circuit board	IQ Gateway is the platform for total energy management for comprehensive, remote maintenance, and management of the Enphase Energy System
Busbar	80 A busbar with support for 1 × IQ Gateway breaker and 4 × 20 A breaker for installing IQ Series Microinverters and IQ Battery 5P
IQ Gateway breaker	Circuit breaker, 2-pole, 10 A/15 A
Production CT	Pre-wired revenue-grade solid-core CT, accurate up to ±0.5%
Consumption CT	Two consumption metering clamp CTs, shipped with the box, accurate up to ±2.5%
IQ Battery CT	One battery metering clamp CT, shipped with the box, accurate up to ±2.5%
CTRL board	Control board for wired communication with IQ System Controller 3/3G and the IQ Battery 5P
Enphase Mobile Connect (only with IQ Combiner 5C)	4G-based LTE-M1 cellular modem (CELLMODEM-M1-06-SP-05) with a 5-year T-Mobile data plan
Accessories kit	Spare control headers for the COMMS-KIT-02 board

ACCESSORIES AND REPLACEMENT PARTS (NOT INCLUDED, ORDER SEPARATELY)	
CELLMODEM-M1-06-SP-05	4G-based LTE-M1 cellular modem with a 5-year T-Mobile data plan
CELLMODEM-M1-06-AT-05	4G-based LTE-M1 cellular modem with a 5-year AT&T data plan
Circuit breakers (off-the-shelf)	Supports Eaton BR2XX, Siemens Q2XX and GE/ABB THQL21XX Series circuit breakers (XX represents 10, 15, 20, 30, 40, 50, or 60). Also supports Eaton BR220B, BR230B, and BR240B circuit breakers compatible with the hold-down kit.
Circuit breakers (provided by Enphase)	BRK-10A-2-240V, BRK-15A-2-240V, BRK-20A-2P-240V, BRK-15A-2P-240V-B, and BRK-20A-2P-240V-B (more details in the "Accessories" section)
XA-SOLARSHIELD-ES	Replacement solar shield for IQ Combiner 5/5C
XA-ENV2-PCBA-5	IQ Gateway replacement printed circuit board (PCB) for IQ Combiner 5/5C
X-IQ-NA-HD-125A	Hold-down kit compatible with Eaton BR-B Series circuit breakers (with screws)
XA-COMMS2-PCBA-5	Replacement COMMS-KIT-02 printed circuit board (PCB) for IQ Combiner 5/5C

ELECTRICAL SPECIFICATIONS	
Rating	80 A
System voltage and frequency	120/240 VAC, 60 Hz
Busbar rating	125 A
Fault current rating	10 kAIC
Maximum continuous current rating (input from PV/storage)	64 A
Branch circuits (solar and/or storage)	Up to four 2-pole Eaton BR, Siemens Q, or GE/ABB THQL Series distributed generation (DG) breakers only (not included)
Maximum total branch circuit breaker rating (input)	80 A of distributed generation/95 A with IQ Gateway breaker included
IQ Gateway breaker	10 A or 15 A rating GE/Siemens/Eaton included
Production metering CT	200 A solid core pre-installed and wired to IQ Gateway
Consumption monitoring CT (CT-200-CLAMP)	A pair of 200 A clamp-style current transformers is included with the box
IQ Battery metering CT	200 A clamp-style current transformer for IQ Battery metering, included with the box

1. A plug-and-play industrial-grade cell modem for systems of up to 60 microinverters. Available in the United States, Canada, Mexico, Puerto Rico, and the US Virgin Islands, where there is adequate cellular service in the installation area.

Accessories



Mobile Connect

4G-based LTE-M1 cellular modem with a 5-year data plan (CELLMODEM-M1-06-SP-05 for Sprint and CELLMODEM-M1-06-AT-05 for AT&T)



Circuit breakers

BRK-10A-2-240V Circuit breaker, 2-pole, 10 A, Eaton BR210
BRK-15A-2-240V Circuit breaker, 2-pole, 15 A, Eaton BR215
BRK-20A-2P-240V Circuit breaker, 2-pole, 20 A, Eaton BR220
BRK-15A-2P-240V-B Circuit breaker, 2-pole, 15 A, Eaton BR215B with hold-down kit support
BRK-20A-2P-240V-B Circuit breaker, 2-pole, 20 A, Eaton BR220B with hold-down kit support



CT-200-SOLID

200 A revenue-grade solid core Production CT with <0.5% error rate (replacement SKU)



CT-200-CLAMP

200 A clamp-style consumption and battery metering CT with <2.5% error rate (replacement SKU)

MECHANICAL DATA

Dimensions (W × H × D)	37.5 cm × 49.5 cm × 16.8 cm (14.75" × 19.5" × 6.63"). Height is 21.06" (53.5 cm) with mounting brackets
Weight	7.5 kg (16.5 lbs)
Ambient temperature range	-40°C to 46°C (-40°F to 115°F)
Cooling	Natural convection, plus heat shield
Enclosure environmental rating	Outdoor, NRTL-certified, NEMA type 3R, polycarbonate construction
Wire sizes	<ul style="list-style-type: none"> 20 A to 50 A breaker inputs: 14 to 4 AWG copper conductors 60 A breaker branch input: 4 to 1/0 AWG copper conductors Main lug combined output: 10 to 2/0 AWG copper conductors Neutral and ground: 14 to 1/0 copper conductors Always follow local code requirements for conductor sizing
Communication (in-premise connectivity)	Built-in CTRL board for wired communication with IQ Battery 5P and IQ System Controller 3/3G. Integrated power line communication for IQ Series Microinverters
Altitude	Up to 2,600 meters (8,530 feet)

COMMUNICATION INTERFACES

Integrated Wi-Fi	802.11b/g/n (dual band 2.4 GHz/5 GHz), for connecting the Enphase Cloud through the internet
Wi-Fi range (recommended)	10 m (32.8 feet)
Bluetooth	BLE4.2, 10 m range to configure Wi-Fi SSID
Ethernet	Optional, 802.3, Cat5E (or Cat 6) UTP Ethernet cable (not included), for connecting to the Enphase Cloud through the internet
Cellular/Mobile Connect	CELLMODEM-M1-06-SP-05 or CELLMODEM-M1-06-AT-05 (included with IQ Combiner 5C)
Digital I/O	Digital input/output for grid operator control
USB 2.0	Mobile Connect, COMMS-KIT-01 for IQ Battery 3/3T/10/10T, COMMS-KIT-02 for IQ Battery 5P
Access point (AP) mode	For connection between the IQ Gateway and a mobile device running the Enphase Installer App
Metering ports	Up to two Consumption CTs, one IQ Battery CT, and one Production CT
Power line communication	90–110 kHz
Web API	See https://developer-v4.enphase.com
Local API	See guide for local API

COMPLIANCE

IQ Combiner with IQ Gateway	UL 1741, CAN/CSA C22.2 No. 107.1, Title 47 CFR, Part 15, Class B, ICES 003, NOM-208-SCFI-2016, UL 60601-1/CANCSA 22.2 No. 61010-1, IEEE 1547: 2018 (UL 1741-SB, 3rd Ed.), IEEE 2030.5/CSIP Compliant, Production metering: ANSI C12.20 accuracy class 0.5 (PV production)
-----------------------------	---

COMPATIBILITY

PV	Microinverters	IQ6, IQ7, and IQ8 Series Microinverters
	IQ System Controller	EP200G101-M240US00
COMMS-KIT-01 ²	IQ System Controller 2	EP200G101-M240US01
	IQ Battery	ENCHARGE-3-1P-NA, ENCHARGE-10-1P-NA, ENCHARGE-3T-1P-NA, ENCHARGE-10T-1P-NA
COMMS-KIT-02 ³	IQ System Controller 3	SC200D111C240US01, SC200G111C240US01
	IQ Battery	IQBATTERY-5P-1P-NA

2. For information about IQ Combiner 5/5C compatibility with the 2nd-generation batteries, refer to the [compatibility matrix](#).
3. IQ Combiner 5/5C comes pre-equipped with COMMS-KIT-02.

Enphase IQ Envoy

The **Enphase IQ Envoy™** communications gateway delivers solar production and energy consumption data to Enphase Enlighten™ monitoring and analysis software for comprehensive, remote maintenance and management of the Enphase IQ System.

With integrated revenue grade production metering and optional consumption monitoring, Envoy IQ is the platform for total energy management and integrates with the Enphase Ensemble™ and the Enphase IQ Battery™.



Smart

- Enables web-based monitoring and control
- Bidirectional communications for remote upgrades
- Supports power export limiting and zeroexport applications

Simple

- Easy system configuration using Enphase Installer Toolkit™ mobile app
- Flexible networking with Wi-Fi, Ethernet, or cellular

Reliable

- Designed for installation indoors or outdoors
- Five-year warranty

Enphase IQ Envoy

MODEL NUMBERS

Enphase IQ Envoy™ ENV-IQ-AM1-240	Enphase IQ Envoy communications gateway with integrated revenue grade PV production metering (ANSI C12.20 +/- 0.5%) and optional consumption monitoring (+/- 2.5%). Includes one 200A continuous rated production CT (current transformer).
-------------------------------------	---

ACCESORIES (Order Separately)

Enphase Mobile Connect™ CELLMODEM-M1 (4G based LTE-M/5-year data plan) CELLMODEM-M1-B (4G-based LTE-M1/5-year data plan)	Plug and play industrial grade cellular modem with data plan for systems up to 60 microinverters. (Available in the US, Canada, Mexico, Puerto Rico, and the US Virgin Islands, where there is adequate cellular service in the installation area.)
Consumption Monitoring CT CT-200-SPLIT	Split-core consumption CTs enable whole home metering.
Ensemble Communications Kit COMMS-KIT-01	Installed at the IQ Envoy. For communications with Enphase Encharge™ storage and Enphase Enpower™ smart switch. Includes USB cable for connection to IQ Envoy or Enphase IQ Combiner™ and allows wireless communication with Encharge and Enpower.

POWER REQUIREMENTS

Power requirements	120/240 VAC split-phase. Max 20 A overcurrent protection required.
Typical Power Consumption	5W

CAPACITY

Number of microinverters polled	Up to 600
---------------------------------	-----------

MECHANICAL DATA

Dimensions (WxHxD)	21.3 x 12.6 x 4.5 cm (8.4" x 5" x 1.8")
Weight	17.6 oz (498 g)
Ambient temperature range	-40° to 65° C (-40° to 149° F) -40° to 46° C (-40° to 115° F) if installed in an enclosure
Environmental rating	IP30. For installation indoors or in an NRTL-certified, NEMA type 3R enclosure.
Altitude	To 2000 meters (6,560 feet)
Production CT	- Limited to 200A of continuous current / 250A OCPD – 72kW AC - Internal aperture measures 19.36mm to support 250MCM THWN conductors (max) - UL2808 certified for revenue grade metering
Consumption CT	- For electrical services to 250A with parallel runs up to 500A - Internal aperture measures 0.84" x 0.96" (21.33mm x 24.38mm) to support 3/0 THWN conductor - UL2808 certified, for use at service entrance for services up to 250Vac

INTERNET CONNECTION OPTIONS

Integrated Wi-Fi	802.11b/g/n
Ethernet	802.3, Cat5E (or Cat 6) UTP Ethernet cable (not included)
Mobile	CELLMODEM-M1 (4G) or CELLMODEM-M1-B (4G). Not included. Note that an Enphase Mobile Connect cellular modem is required for all Ensemble installations.

COMPLIANCE

Compliance	UL 61010-1 CAN/CSA C22.2 No. 61010-1 47 CFR, Part 15, Class B, ICES 003 IEC/EN 61010-1:2010, EN50065-1, EN61000-4-5, EN61000-6-1, EN61000-6-2 Metering: ANSI C12.20 accuracy class 0.5 (PV production only)
------------	--



1403 N. Research Way
Orem, UT 84097

800.377.4480
WWW.BLUERAVENSOLAR.COM

CONFIDENTIAL- THE INFORMATION HEREIN CONTAINED SHALL NOT BE USED FOR THE BENEFIT OF ANYONE EXCEPT BLUE RAVEN SOLAR NOR SHALL IT BE DISCLOSED IN WHOLE OR IN PART TO OTHERS OUTSIDE RECIPIENTS ORGANIZATION, EXCEPT IN CONNECTION WITH THE SALE AND USE OF THE RESPECTIVE EQUIPMENT, WITHOUT THE WRITTEN PERMISSION OF BLUE RAVEN SOLAR LLC.



PV INSTALLATION
PROFESSIONAL

Scott Gurney
#PV-011719-015866

CONTRACTOR:
BRS FIELD OPS
385-498-6700

DRAWING BY:

PLOT DATE:

PROJECT NUMBER:

SHEET NAME:

SPEC SHEET

REVISION:

PAGE NUMBER:

SS



To learn more about Enphase offerings, visit enphase.com



To learn more about Enphase offerings, visit enphase.com

© 2021 Enphase Energy. All rights reserved. Enphase, the Enphase logo, IQ Envoy, and other trademarks or service names are the trademarks of Enphase Energy, Inc. Data subject to change. 06-30-2021



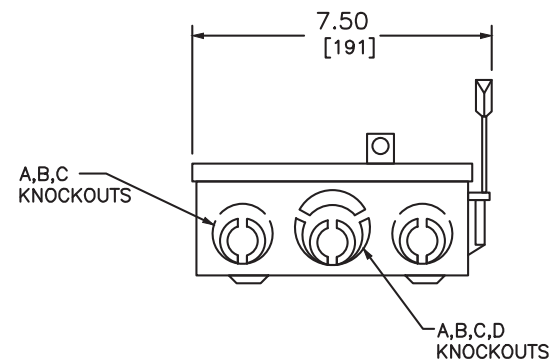
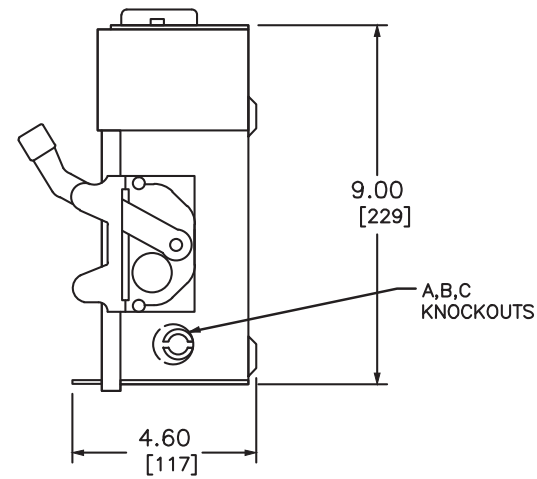
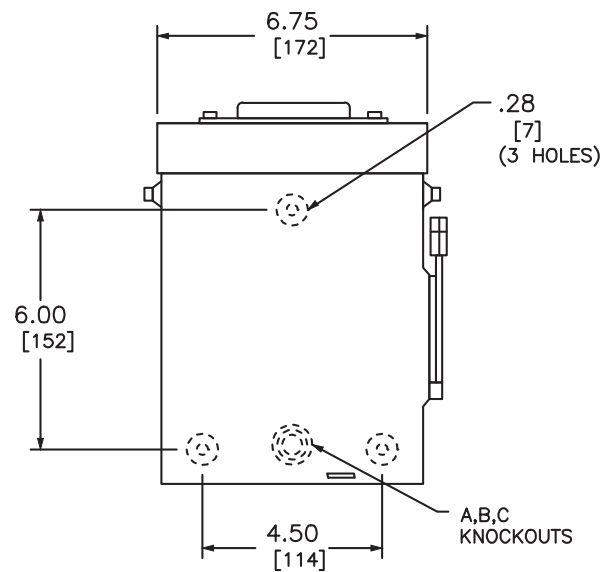

NEMA TYPE 3R
ILLUSTRATED

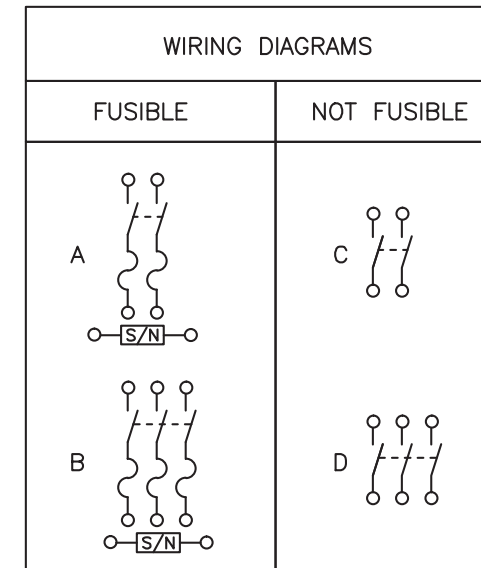

TERMINAL LUGS ‡

AMPERES	MAX. WIRE	MIN. WIRE	TYPE
30	# 6 AWG	# 12 AWG	AL
	# 6 AWG	# 14 AWG	CU

KNOCKOUTS

SYMBOL	A	B	C	D
CONDUIT SIZE	.50	.75	1	1.25

DUAL DIMENSIONS: INCHES
MILLIMETERS

CATALOG NUMBER	VOTAGE RATINGS	WIRING DIAG.	HORSEPOWER RATINGS					
			120VAC		240VAC			
			STD.	MAX.	STD.		MAX.	
			1 Ø	1 Ø	1 Ø	3 Ø	1 Ø	3 Ø
D211NRB●■	240VAC	A	1/2	2	1 1/2	-	3	-
D221NRB	240VAC	A	-	-	1 1/2	3*	3	7 1/2*
D321NRB	240VAC	B	-	-	1 1/2	3	3	7 1/2
DU221RB	240VAC	C	-	-	-	-	3	-
DU321RB	240VAC	D	-	-	-	-	3	7 1/2

NOTES:
 FINISH - GRAY BAKED ENAMEL ELECTRODEPOSITED OVER CLEANED PHOSPHATIZED STEEL.
 UL LISTED - FILE E-2875
 ALL NEUTRALS - INSULATED GROUNDABLE
 SUITABLE FOR USE AS SERVICE EQUIPMENT
 TOP OF NEMA TYPE 3R SWITCHES HAVE PROVISIONS FOR MAXIMUM 2 1/2" BOLT-ON HUB.
 SHORT CIRCUIT CURRENT RATINGS:
 ● 10,000 AMPERES.
 ■ 10,000 AMPERES WHEN USED WITH OR PROTECTED BY CLASS H OR K FUSES.
 ■ 100,000 AMPERES WITH CLASS R FUSES.
 * FOR CORNER GROUNDED DELTA SYSTEMS.
 ■ PLUG FUSES
 ‡ LUGS SUITABLE FOR 60°C OR 75° CONDUCTORS.

GENERAL DUTY SAFETY SWITCHES
 VISIBLE BLADE TYPE
 30 AMPERE
 ENCLOSURE - NEMA TYPE 3R RAINPROOF



DWG# 1852
NO.

A. System Specifications and Ratings

- Maximum Voltage: 1,000 Volts
- Maximum Current: **JB-1.2:** 80 Amps; **JB-1.XL:** 120 Amps
- Allowable Wire: 14 AWG – 6 AWG
- Spacing: Please maintain a spacing of at least ½” between uninsulated live parts and fittings for conduit, armored cable, and uninsulated live parts of opposite polarity.
- Enclosure Rating: Type 3R
- Roof Slope Range: 2.5 – 12:12
- Max Side Wall Fitting Size: 1”
- Max Floor Pass-Through Fitting Size: 1”
- Ambient Operating Conditions: (-35°C) - (+75°C)
- Compliance:
 - **JB-1.2:** UL1741, CSA C22.2 No. 290; **JB-1.XL:** UL1741, CSA C22.2 No. 290
 - Approved wire connectors: must conform to UL1741, CSA C22.2 No. 290
- System Marking: **Interek Symbol and File #5019942**
- Periodic Re-inspections: If re-inspections yield loose components, loose fasteners, or any corrosion between components, components that are found to be affected are to be replaced immediately.



Table 1: Typical Wire Size, Torque Loads and Ratings

	1 Conductor	2 Conductor	Torque				
			Type	NM	Inch Lbs	Voltage	Current
ABB ZS6 terminal block	10-24 awg	16-24 awg	Sol/Str	0.5-0.7	6.2-8.85	600V	30 amp
ABB ZS10 terminal block	6-24 awg	12-20 awg	Sol/Str	1.0-1.6	8.85-14.16	600V	40 amp
ABB ZS16 terminal block	4-24 awg	10-20 awg	Sol/Str	1.6-2.4	14.6-21.24	600V	60 amp
ABB M6/8 terminal block	8-22 awg		Sol/Str	.08-1	8.85	600V	50 amp
Ideal 452 Red <small>WING-NUT Wire Connector</small>	8-18 awg		Sol/Str	Self-Torque	Self-Torque	600V	
Ideal 451 Yellow <small>WING-NUT Wire Connector</small>	10-18 awg		Sol/Str	Self-Torque	Self-Torque	600V	
Ideal, In-Sure <small>Push-In Connector Part #39</small>	10-14 awg		Sol/Str	Self-Torque	Self-Torque	600V	
WAGO, 2204-1201	10-20 awg	16-24 awg	Sol/Str	Self-Torque	Self-Torque	600V	30 amp
WAGO, 221-612	10-20 awg	10-24 awg	Sol/Str	Self-Torque	Self-Torque	600V	30 amp
Dottie DRC75	6-12 awg		Sol/Str	Snap-In	Snap-In		
ESP NG-53	4-6 awg		Sol/Str		45	2000V	
	10-14 awg		Sol/Str		35		
ESP NG-717	4-6 awg		Sol/Str		45	2000V	
	10-14 awg		Sol/Str		35		
Brumall 4-5,3	4-6 awg		Sol/Str		45	2000V	
	10-14 awg		Sol/Str		35		

Table 2: Minimum wire-bending space for conductors through a wall opposite terminals in mm (inches)

Wire size, AWG or kcmil (mm2)	Wires per terminal (pole)			
	1 mm (inch)	2 mm (inch)	3 mm (inch)	4 or More mm (inch)
14-10 (2.1-5.3)	Not Specified	-	-	-
8 (8.4)	38.1 (1-1/2)	-	-	-
6 (13.3)	50.8 (2)	-	-	-

ITEM NO.	PART NUMBER	DESCRIPTION	QTY
1	JB-1.2 BODY	POLYCARBONATE WITH UV INHIBITORS	1
2	JB-1.2 LID	POLYCARBONATE WITH UV INHIBITORS	1
3	#10 X 1-1/4" PHILLIPS PAN HEAD SCREW		6
4	#8 X 3/4" PHILLIPS PAN HEAD SCREW		6

SIZE	DWG. NO.	REV
B	JB-1.2	
SCALE: 1:2	WEIGHT: 1.45 LBS	SHEET 1 OF 3
TORQUE SPECIFICATION:	15-20 LBS	
CERTIFICATION:	UL 1741, NEMA 3R CSA C22.2 NO. 290	
WEIGHT:	1.45 LBS	

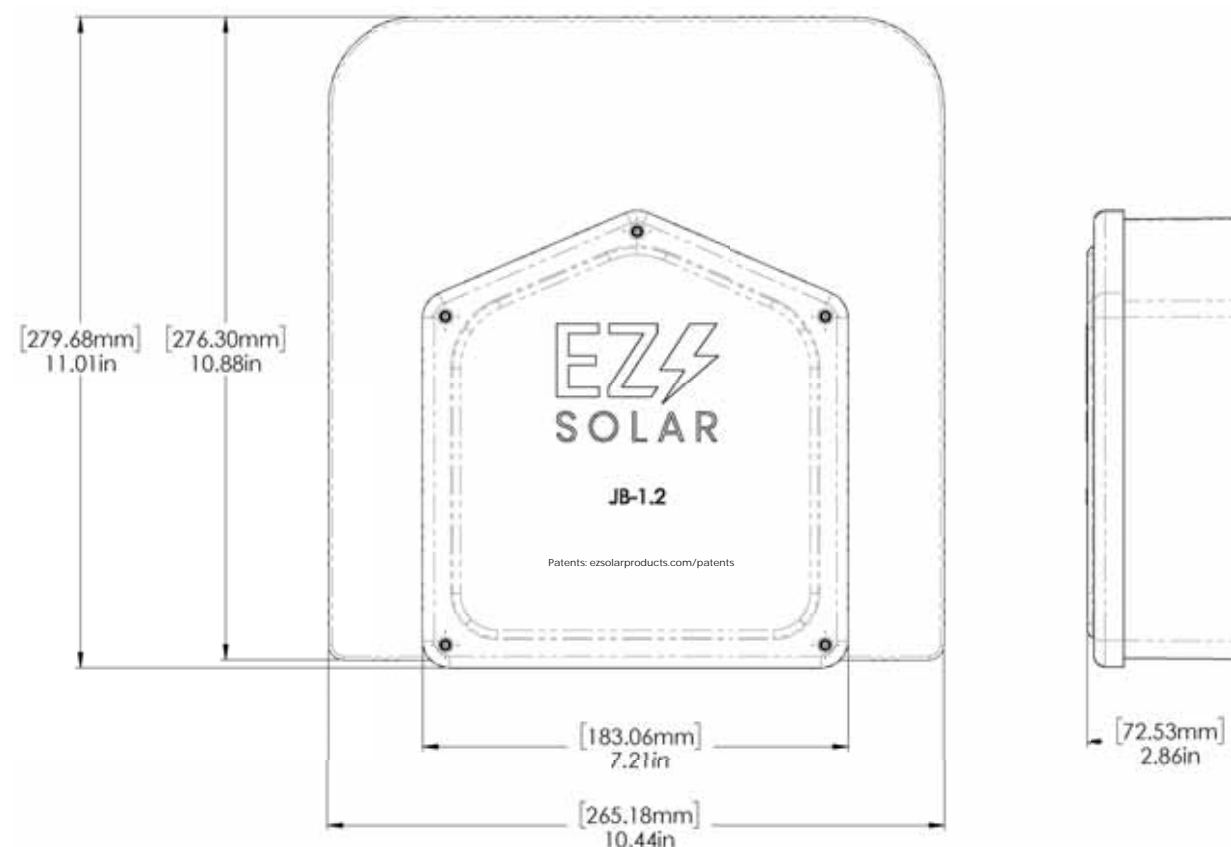

PROPRIETARY AND CONFIDENTIAL: THE INFORMATION CONTAINED IN THIS DRAWING IS THE SOLE PROPERTY OF EZ SOLAR. ANY REPRODUCTION IN PART OR AS A WHOLE WITHOUT THE WRITTEN PERMISSION OF EZ SOLAR IS PROHIBITED.



DRAWING NUMBER:

SS

RIGID PVC CONDUIT FITTINGS

JB444 JUNCTION BOXES

ISSUE DATE:
DATE D'EMISSION: 2009 04 30

SUPERCEDES:
REPLACE: 2004 07 15

RIGID PVC CONDUIT FITTINGS

JB444 JUNCTION BOXES

ISSUE DATE:
DATE D'EMISSION: 2009 04 30

SUPERCEDES:
REPLACE: 2004 07 15

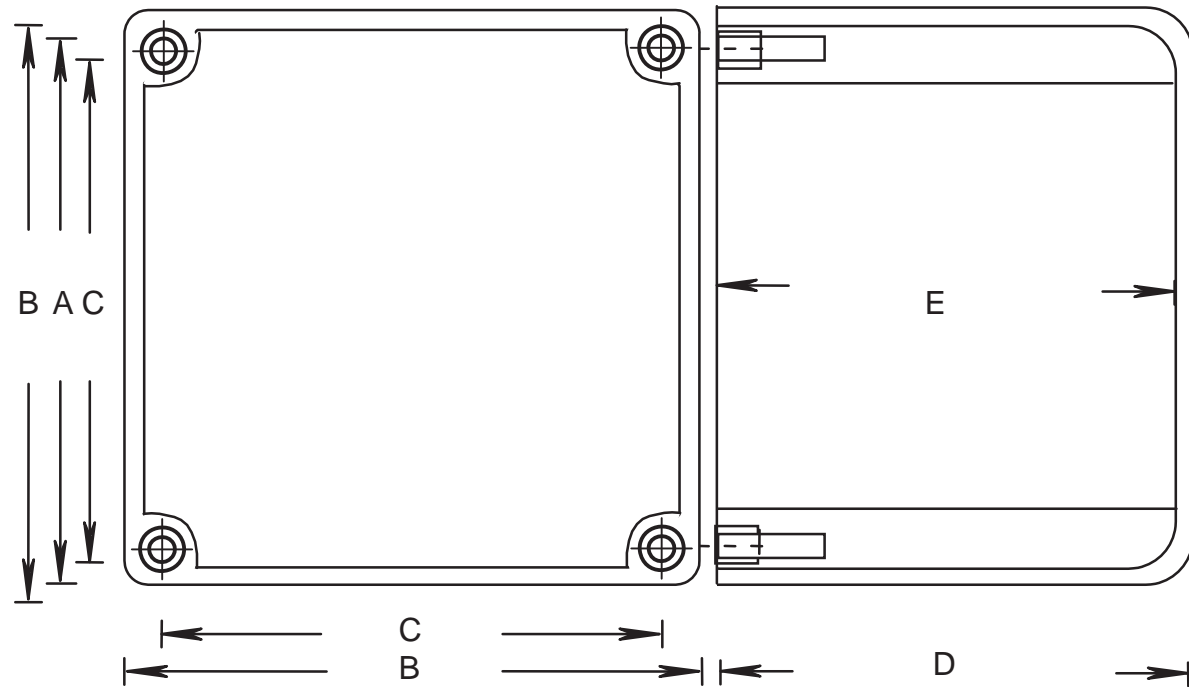

COVER DIMENSIONS

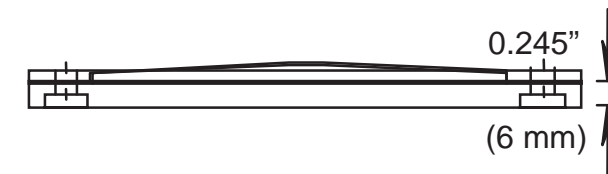
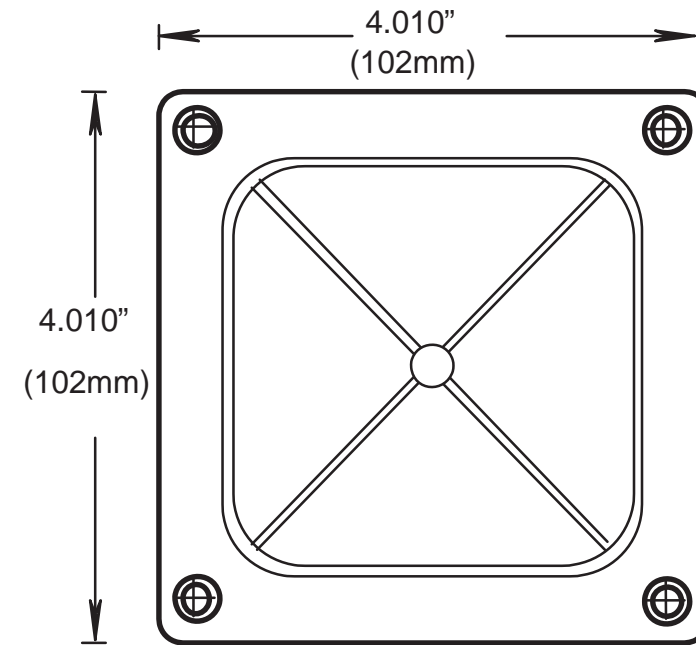

PRODUCT CODE	PART NUMBER	NOMINAL SIZE		A		B		C	
		(in)	(mm)	(in)	(mm)	(in)	(mm)	(in)	(mm)
076668	J444 STAHLIN	4	103	3.675	93	4.000	102	3.450	88
076259	AMJB444 ALLIED	4	103	3.675	93	4.000	102	3.450	88
077643*	2037-424T CANLET	4	103	3.675	93	4.000	102	3.450	88
077696	JB 444	4	103	4.000	101	4.395	112	3.950	101

PRODUCT CODE	PART NUMBER	NOMINAL SIZE		D		E		VOLUME	
		(in)	(mm)	(in)	(mm)	(in)	(mm)	(cu. In)	(cu. Cm)
076668	J444 STAHLIN	4	103	4.180	106.	3.850	98	51.5	844.6
076259	AMJB444 ALLIED	4	103	4.180	106	3.850	98	51.5	844.6
077643*	2037-424T CANLET	4	103	4.180	106	3.850	98	51.5	844.6
077696	JB 444	4	103	4.170	106	3.930	100	51.5	844.6

PRODUCT CODE	PART NUMBER	NOMINAL SIZE		GASKET CODE	INSERT CODE	SCREW CODE	M.FEET CODE
		(in)	(mm)				
076668	J444 STAHLIN	4	103		072538 (4)		
076259	AMJB444 ALLIED	4	103		072538 (4)		
077643*	2037-424T CANLET	4	103		072538 (4)		
077696	JB 444	4	103	097731	072538 (4) 072539 (2)	072522 (4) 072513 (2)	097747

* BOX WITH MOLDED MOUNTING FEET, INSERT ONLY; NO COVER, OR GASKET, UL LISTED 576J

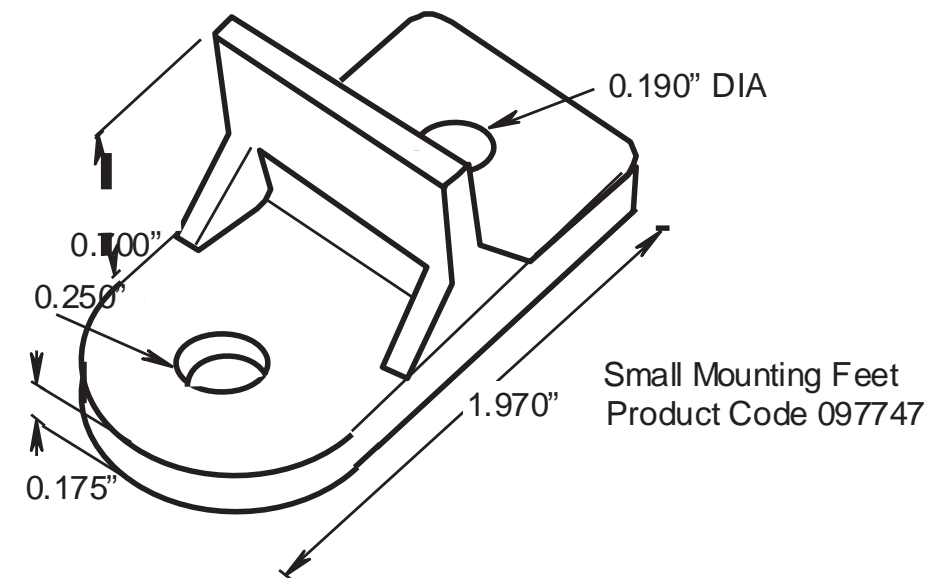

Small Mounting Feet
Product Code 097747

“Stay Connected” with **HEYCO** Solar Power Components
a PennEngineering® Company

Heyco®-Tite Liquid Tight Cordgrips for Enphase Q Cables

Straight-Thru, NPT Hubs with Integral Sealing Ring

The Ultimate in Liquid Tight Strain Relief Protection

ALL NEW
PRODUCT!



GLAND CONFIGURATION Conductors	PART NO.	DESCRIPTION	UL/CSA or SA	PART DIMENSIONS											
				A Clearance Hole Dia.	B Max. O.A. Length	C Thread Length	D Wrenching Nut Thickness	E Flat Size							
Type * Size mm.	No.	Black		in.	mm.	in.	mm.	in.	mm.	in.	mm.				
Oval Gland															
Q Cable	6,1 x 9,7	1	M3231GCZ	LTCG 1/2 6.1x9.7MM	UL/CSA	.875	22,2	1.70	43,2	.61	15,5	.21	5,3	.98	24,9
Break-Thru Skinned Over Gland															
Q Cables plus Ground	6,1 x 9,7 3,3	2 1	M3234GDA-SM	SMCG 3/4 2-6.1x9.7MM 1-3.3MM	UL/CSA	1.040	26,4	2.00	50,8	.62	15,7	.25	6,4	1.30	33,0

Metal Locknuts INCLUDED.

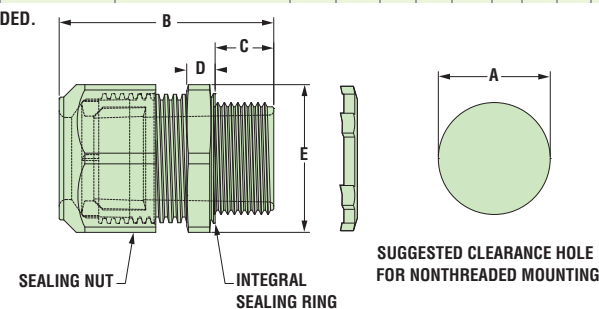

Material	Nylon 6/6 with TPE Sealing Gland
Certifications	UL Listed under Underwriters' Laboratories File E504900 CSA Certified by the Canadian Standards Association File 93876
Flammability Rating	94V-2
Temperature Range	Static -40°F (-40°C) to 239°F (115°C) Dynamic -4°F (-20°C) to 212°F (100°C)
IP Rating	IP 68

- Two new cordgrips now accommodate the Enphase Q Cable – M3231GCZ (1/2" NPT) and M3234GDA-SM (3/4" NPT).
- The 1/2" version provides liquid tight entry for one Enphase Q Cable – .24 x .38" (6,1 x 9,7 mm).
- The 3/4" version provides liquid tight entry for up to two Enphase Q Cables – .24 x .38" (6,1 x 9,7 mm) and an additional .130" (3,3 mm) dia. hole for a #8 solid grounding cable.
- The 3/4" version utilizes our skinned-over technology so any unused holes will retain a liquid tight seal.
- Rated for use with DG Cable.

Heyco® Helios® UVX Clip – Blind Mount

ALL NEW
PRODUCT!



PANEL THICKNESS RANGE		WIRE DIAMETER RANGE 1-2 Wires		PART NO.	DESCRIPTION	MOUNTING HOLE DIA. A		OVERALL HEIGHT C		
Minimum in.	Maximum mm.	Minimum in.	Maximum mm.			in.	mm.	in.	mm.	
1-2 Wires										
.028	0,7	.250	6,4	.23 (5,8 mm) - .32 (8,0 mm) each cable	S6520 S6560	Helios UVX Clip 100 Pack Helios UVX Clip Bulk	.260	6,6	.96	24,4

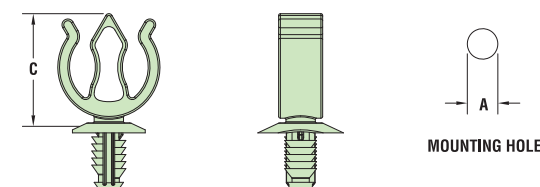

Material	Nylon 6/6 with extended UV Capabilities
Flammability Rating	94V-2
Temperature Range	Dynamic -4°F (-20°C) to 185°F (85°C)

- The jersey pine tree mounting style installs easily with superior holding power.
- UVX nylon protects from corrosion due to outdoor exposure.
- Installs into .260" (6,6 mm) mounting hole.
- Holds up to 2 cables between .230 - .315" (5,8 - 8,0 mm) each.
- Cables install with fingertip pressure.
- Molded from our robust UVX nylon 6/6 with extended UV capabilities for our Solar 20 Year Warranty.



RAIL SYSTEM



RAIL SYSTEM



Instant Bonding

The N-S Bonding Jumper bonds row to row with no tools.



One Clamp Anywhere

The Multi-Clamp works as mid- or end-clamp, and fits standard 30-40mm frames.



Lifetime Wire Management

Open rail channel holds and protects wires. Clamps won't pinch wires after tightening.



Bonding Structural Splice

Connect rails instantly, without tools, interference or limitations.

Next-Level Solar Mounting

A complete system for hassle-free rooftop installation, from watertight mounts to lifetime wire management.



Simplicity

1/2" socket for everything. One clamp for mid or end. No tool splicing and bonding. Easy wire management.



Code Compliant

UL 2703 listed
LTR-AE-001-2012 listed
Class A fire rating for any slope
ASCE 7-16 PE Certified
FL Cert of Approval FL41396



Premium Aesthetics

The narrowest panel gap available. Optional Hidden End Clamps and End Caps provide a flush look on the edge of the array.



Watertight for Life

Secured on industry-leading Pegasus Mounts, for composite shingle and tile roofs. Backed by a 25-year warranty.



Pegasus Rail

Available in 14' and 7' lengths for easy layout and shipping. Open-channel design holds MC4 connectors, PV wire and trunk cables. Black and Mill finish



Pegasus Max Rail

Maximum-strength design. Meets specifications for high snow-load and hurricane zones. Black and Mill finish



Splice and Max Splice

Installs by hand. Works over mounts. Structurally connects and bonds rails automatically; UL2703 listed as reusable.



Dovetail T-bolt

Dovetail shape for extra strength. Uses 1/2" socket.



Multi-Clamp

Fits 30-40mm PV frames, as mid- or end-clamp. Twist-locks into position; doesn't pinch wires in rail. Bonds modules to rail; UL2703 listed as reusable



Hidden End Clamp

Offers premium edge appearance. Preinstalled pull-tab grips rail edge, allowing easy, one-hand installation. Tucks away for reuse.



Ground Lug

Holds 6 or 8 AWG wire. Mounts on top or side of rail. Assembled on MLPE Mount. UL2703 listed as reusable.



N-S Bonding Jumper

Installs by hand, eliminates row-to-row copper wire. UL2703 listed as reusable only with Pegasus Rail.



MLPE Mount

Secures and bonds most micro-inverters and optimizers to rail. Connectors and wires easily route underneath after installation. UL2703 listed as reusable.



Cable Grip

Secures four PV wires or two trunk cables. Stainless-steel backing provides durable grip. Eliminates sagging wires.



Wire Clip

Hand operable. Holds wires in channel. Won't slip.



End Cap and Max End Cap

Fits flush to PV module and hides raw or angled cuts. Hidden drain quickly clears water from rail.

Certifications:

- UL 2703, Edition 1
- LTR-AE-001-2012
- ASCE 7-16 PE certified
- Class A fire rating for any slope roof
- FL Cert of Approval FL41396



Quickly calculate the most efficient layout, spans and materials needed to suit your job. Visit the Pegasus Customer Portal. pegasussolar.com/portal

Patents pending. All rights reserved. ©2023 Pegasus Solar Inc.

LOAD		SPAN				
SNOW (psf)	WIND (MPH)	32"	48"	72"	96"	120"
0	100	PEGASUS RAIL	PEGASUS RAIL	PEGASUS RAIL	PEGASUS MAX RAIL	PEGASUS MAX RAIL
	130					
10	140	PEGASUS RAIL	PEGASUS RAIL	PEGASUS RAIL	PEGASUS MAX RAIL	PEGASUS MAX RAIL
	190					
30	190	PEGASUS RAIL	PEGASUS RAIL	PEGASUS RAIL	PEGASUS MAX RAIL	PEGASUS MAX RAIL
50						
100						
120		PEGASUS RAIL	PEGASUS RAIL	PEGASUS RAIL	PEGASUS MAX RAIL	PEGASUS MAX RAIL

For reference only. Spans above are calculated using 7-16 for a Gable Roof, Exposure Category B, 0-20deg roof angle, 30ft mean roof height with non-exposed modules. For PE certified span tables, visit www.pegasussolar.com/spans.

Appendix A - Compatible PV Mod-

Pegasus Rail System may be used to ground a PV module complying with UL 2703 only when the specific module has been evaluated for grounding and/or mounting in compliance with this installation manual. Unless otherwise specified, "xxx" refers to the power rating of the PV module. Both black & silver frames are included in the UL2703 listing.



Manufacturer	Model
Auxin	AXN6M612Txxx
Aptos	DNA-144-BF26-xxxW; DNA-144-MF26-xxxW; DNA-120-BF26-xxxW; DNA-120-MF26-xxxW; DNA-120-MF10-xxxW; DNA-120-BF10-xxxW; DNA-108-BF10-xxxW; DNA-108-MF10-xxxW; DNA-120MF23-xxxW
Axitec	AC-xxxM/156-60S; AC-xxxM/60S; AC-xxxMH/120S; AC-xxxMH/144S; AC-xxxMBT/108V
Boviet	BVM6610M-xxx; BVM6610P-xxx
Canadian Solar	CS1H-xxxMS; CS1K-xxxMS; CS1Y-xxxMS; CS3K-xxxMS; CS3U-xxxMS; CS6K-xxxM; CS6K-xxxMS; CS6K-xxxP; CS6U-xxxM; CS6U-xxxP; CS6X-xxxM; CS6X-xxxP; BiHiKu CS3W-xxxMB-AG; CS3L-xxxMS; CS6R-xxxMS; CS3W-xxxPB-AG; CS3W-xxxP; CS3W-xxxMS; CS3L-xxxP; CS3L-xxxMS; CS3N-xxxMS; CS6W-xxxMB-AG; CS7N-xxxMB-AG; CS6.1-54TM-xxxH; CS6.1-60TM-xxxH
CertainTeed	CTxxxHC11-04; CTxxxM10-02; CTxxxM11-02; CTxxxM11-03; CTxxxHC00-04; CTxxxHC12-06; CTxxxHC11-06; CTM10440HC11-09
Chint Solar	CHSM6612M-xxx
Freedom Forever	FF-MP-BBB-xxx
Hansol	HSxxxTD-AN3
Heliene	Heliene20M xxx; Heliene36M xxx; Heliene36P xxx; Heliene60M xxx; Heliene60P xxx; Heliene72M Bifacial xxx; Heliene72P xxx; Heliene96M xxx Bifacial; Heliene96M xxx; Heliene 96P xxx; HSPE-144M M6 HC Bifacial xxx; HSPE 120M M6 HC Monofacial xxx; 144HC-M10-Bifacial; 46C-144M-HC-M6
Hyperion	HY-DH108P8B-xxx
Hyundai	HiD-SxxxRG(BK); HiS-MxxxRG; HiS-SxxxK; HiS-SxxxRG; HiS-SxxxRG(BK); HiS-SxxxRT; HiS-SxxxTI; HiA-SxxxHI; HiS-SxxxXG(BK); HiN-SxxxXG(BK); HiS-SxxxYH(BK); HiS-SxxxYH(BK)
Imperial Star	ISM7-SHDD108-xxx/M; ISM7-SHSB108-xxx/M
JA Solar	JAM72S01-xxx/PR; JAP72S01-xxx/SC; JAM72D2C-xxx/MB; JAM54S30-xxx/LR; JAM72D3C-xxx-MB-DS; JAM54S31-xxx-MR
Jinko	JKMxxxM-60; JKMxxxM-60B; JKMxxxM-60BL; JKMxxxM-60HBL; JKMxxxM-60HL; JKMxxxM-60L; JKMxxxM-60-Y; JKMxxxM-72; JKMxxxM-72HL-V; JKMxxxM-72H-V; JKMxxxM-72-V; JKMxxxP-60; JKMxxxPP-60; JKMxxxN-6RL3; JKMxxxM-6RL3-B; JKMxxxM-7RL3-TV; JKMxxxM-72HBL-V; JKMxxxN-54HL4-B
LG	LGN1K-G4; LGS1C-A5; LGxxxA1C-A5; LGxxxE1C-A5; LGxxxN1C-A3; LGxxxN1C-A5; LGxxxN1C-B3; LGxxxN1C-G3; LGxxxN1C-G4; LGxxxN1C-V5; LGxxxN1C-Z4; LGxxxN1K-A5; LGxxxN1K-G4; LGxxxN1K-V5; LGxxxN1K-Z4; LGxxxN2T-A5; LGxxxN2W-A5; LGxxxN2W-V5; LGxxxN2W-L5; LGxxxQ1C-A5; LGxxxQ1C-V5; LGxxxQ1K-A5; LGxxxQ1K-V5; LGxxxS1C-A5; LGxxxS1C-G4; LGxxxS2W-A5; LGxxxN1K-L5; LGxxxNIC-N5; LGxxxM1K-A6; LGxxxN1K-B6; LGxxxQ1C-A6; LGxxxQAC-A6; LGxxxQAK-A6; LGxxxM1C-A6; LGxxxN2W-E6; LGxxxN2T-E6; LGxxxN1K-E6; LGxxxN3K-V6; LGxxxN1C-A6
Longi	LR6-60BP-xxx; LR6-60HPB-xxx; LR6-60HPH-xxx; LR6-60PB-xxx; LR6-60PE-xxx; LR6-60-xxx; LR4-60HPH-xxxM; LR4-HPB-xxxM; LR4-72HPH-xxxM; LR4-72HBD-xxxM; LR5-54HPH-xxxM; LR5-72HBD-xxxM; LR5-54HAB-xxxM; LR5-54HPB-xxxM; LR7-72HGD-xxxM
Maxeon	SPR-MAX3-xxx-COM; SPR-MAX3-xxx-BLK; SPR-MAX5-xxx-COM; SPR-MAX6-xxx-COM; SPR-X21/22-xxx-COM; SPR-MAX3-XXX-BLK-R; SPR-MAX6-XXX-BLK
Meyer Burger	MB_B120AyB-xxx; MB_TG120ByB-xxx; MB_W120AyB-xxx
Mission Solar	MSE60Axxx; MSExxxSB1A; MSExxxSO6J; MSExxxSQ5K; MSExxxSQ5T; MSExxxSQ8K; MSExxxSQ8T; MSExxxSQ9S; MSExxxSX6S; MSExxxSX6W; MSExxxSX5T; MSExxxSX5K; MSExxxSX5R; MSExxxSX6Z; MSExxxSX9R; MSExxxSX9Z; MSExxxSR9S; MSExxxSR8K; MSExxxSR8T; MSExxxHTOB; MS11C-xxxHT4G; MS11C-xxxHT4T; MS11C-xxxHN4G; MSExxxHNDB
Mitrex	Mxxx-L3H; Mxxx-I3H; Mxxx-H1H; Mxxx-B1F; Mxxx-A1F
mSolar	TX110-xxx108BB
Panasonic	VBHNxxxKA01; VBHNxxxKA03; VBHNxxxSA16; VBHNxxxSA16B; VBHNxxxSA17; VBHNxxxSA17E; EVPVxxx; EVPVxxxK; EVPVxxxPK; EVPVxxxH; EVPVxxxHK; EVPVxxxPK
Philadelphia Solar	PS-M60(BF)-xxx; PS-M72(BF)-xxx; PS-MNB144(HCBF)-xxxW
QCells	Q.Peak 265; Q.PEAK BLK-G3.1 xxx; Q.PEAK BLK-G4.1 xxx; Q.PEAK DUO BLK-G5 xxx; Q.PEAK DUO BLK-G5/SC xxx; Q.PEAK DUO BLK-G6+ xxx; Q.PEAK DUO G6+ xxx AC ENP IQ7+; Q.PEAK DUO BLK-G9+ xxx; Q.PEAK DUO L-G5.2 xxx; Q.PEAK DUO L-G5.3 xxx; Q.PEAK DUO-G5 xxx; Q.PEAK DUO-G5/SC xxx; Q.PEAK DUO-G7 xxx; Q.PEAK G4.1 xxx; Q.PEAK G4.1/ Max xxx; Q.PEAK G4.1/SC xxx; Q.PEAK G4.1/TAA xxx; Q.PEAK L-G4.2 xxx; Q.PLUS BFR-G4.1 xxx; Q.PLUS BFR-G4.1/TAA xxx; Q.PLUS L-G4.1 xxx; Q.PLUS L-G4.2 xxx; Q.PLUS L-G4.2/TAA xxx; Q.PRO BFR-G4.1 xxx; Q.PEAK DUO L-G8.2 xxx; Q.PEAK DUO BLK-G8 xxx; Q.PEAK DUO BLK-G8+ xxx; Q.PEAK DUO BLK ML G9 xxx; Q.PEAK DUO BLK ML G9+ xxx; Q.PEAK DUO BLK-G10 xxx; Q.PEAK DUO BLK-G10+ xxx; Q.PEAK DUO ML-G10+; Q.PEAK DUO BLK ML-G10.a+; Q.PEAK DUO XL G10 xxxBFG; Q.PEAK DUC-G10 xxx; Q.PEAK DUC-G10+ xxx; Q.PEAK DUO-G10.a xxx; Q.PEAK DUO-G10.a+ xxx; Q.PEAK DUO BLK-G10.a xxx; Q.PEAK DUO BLK-G10.a+ xxx; Q.PEAK DUO ML-G10 xxx; Q.PEAK DUO ML-G10.a xxx; Q.PEAK DUO ML-G10.a+ xxx; Q.PEAK DUO BLK ML-G10 xxx; Q.PEAK DUO BLK ML-G10+ xxx; Q.PEAK DUO BLK ML-G10.a xxx; Q.PEAK DUO ML-G10+ t xxx; Q.TRON BLK M-G2+ xxx; Q.TRON M-G2+ xxx; Q.TRON XL-G2.3/BFG; Q.PEAK DUO XL-G11S.3/BFG; Q.PEAK DUO XL-G11.3/BFG; Q.PEAK DUO ML-G12S.3 / BFG; Q.PEAK DUO ML-G12S.d / BFG; Q.PEAK DUO BLK M-G2+/AC; Q.PEAK DUO BLK ML-G10.a+; Q.PEAK DUO BLK ML-G10+; Q.PEAK DUO BLK ML-G10.B+



Appendix A - Compatible PV Modules (cont.)

Pegasus Rail System may be used to ground a PV module complying with UL 2703 only when the specific module has been evaluated for grounding and/or mounting in compliance with this installation manual. Unless otherwise specified, "xxx" refers to the power rating of the PV module. Both black & silver frames are included in the UL2703 listing.



Manufacturer	Model
REC	RECxxxNP; RECxxxNP Black; RECxxxPE; RECxxxPE 72; RECxxxPE(BLK); RECxxxTP; RECxxxTP BLK; RECxxxTP2; RECxxxTP2 BLK; RECxxxTP2 BLK Q2; RECxxxTP2 BLK2; RECxxxTP2M; RECxxxTP2S 72; RECxxxAA; RECxxxAA Pure; RECxxxAA Black; RECxxxAA 72; RECxxxAA PURE-F; RECxxxNP3 Black; RECxxxNP2 Black; RECxxxNP2; RECxxxAA Pure-FX; RECxxxAA Pure 2; RECxxxAA PRO L; RECxxxAA Pro M
S-Energy	SNxxxM-10; SNxxxM-10(B); SNxxxM-10T; SC20-60MBE-xxxM
SEG	SEG-xxx-BMA-HV; SEG-xxx-BMA-TB; SEG-xxx-BMA-BG; SEG-xxx-BMB-HV; SEG-xxx-BMA-BG; SEG-xxx-BMD-HV; SEG-xxx-BMD-TB; SEG-xxx-BMB-BG; SEG-xxx-BMC-HV; SEG-xxx-BMC-TB; SEG-xxx-BMC-BG; SEG-xxx-BTD-BG; SEG-xxx-BTB-BG
Silfab	SILxxxBL; SILxxxNL; SLAxxxM; SLAxxxM; SLGxxxM; SSAxxxM; SIL-xxxNX; SIL-xxxHL; SIL-xxxNX; SIL-xxxBK; SIL-xxxHC; SIL-xxxHC+; SIL-xxxBG; SIL-xxxHN; SIL-xxxHM; SIL-520QM; ; SIL-xxx-QD
Sonali	SS-XXXW-M60 M10
Solar4America	S4Axxx-72MH5BB; S4Axxx-60MH5BB; S4Axxx-108MH10BB; S4Axxx-144MH10STT; S4Axxx-108TH10BB; S4Axxx-144TH10STT; S4Axxx-108TH16BB; S4Axxx-144TH16XXX
SolarEver	SE-182*91-xxxM-108N; SE-166*83-xxxM-144; SE-182*91-XXXM-108; SE-182*91-XXXM-144; SE-182*105-xxxM-96-BD
Solaria	PowerXT-xxxR-AC; PowerXT-xxxR-BD; PowerXT-xxxR-BX; PowerXT-xxxR-PD; PowerXT-xxxR-PX; PowerXT-xxxR-PM; PowerXT-xxxR-PL; PowerX-xxxR; PowerX-xxxR-4T
SunPower	SPR-Axxx-G-AC; SPR-E19-xxx; SPR-E19-xxx-D-AC; SPR-E20-xxx; SPR-E20-xxx-C-AC; SPR-E20-xxx-COM; SPR-E20-xxx-D-AC; SPR-E20-xxx-E-AC; SPR-X20-xxx-D-AC; SPR-X20-xxx-E-AC; SPR-X21-xxx; SPR-X21-xxx-BLK; SPR-X21-xxx-BLK-C-AC; SPR-X21-xxx-BLK-D-AC; SPR-X21-xxx-BLK-E-AC; SPR-X21-xxx-C-AC; SPR-X21-xxx-D-AC; SPR-X22-xxx; SPR-X22-xxx-C-AC; SPR-X22-xxx-COM; SPR-X22-xxx-D-AC; SPR-X22-xxx-D-AC; SPR-X22-xxx-E-AC; SPR-xxxE-WHT-D; SPR-xxxNE-WHT-D; SPR-Mxxx-H-AC; SPR-Mxxx-BLK-H-AC
Talesun	TP6L60M; TP6L60M(H); TP7F60M; TP7F60M(H); TP7F54M; TP7F54M
Tesla	SC315B2; SCxxx; SCxxxB1; SCxxxB2; TxxxS; TxxxH; SxxxH
Trina	TSM-xxxDD05A; TSM-xxxDD05A(I); TSM-xxxDD05A.05(I); TSM-xxxDD05A.08(I); TSM-xxxDD05A.18(I); TSM-xxxDD05H.05(I); TSM-xxxDD05H.08(I); TSM-xxxPA05.18; TSM-xxxPD05.05; TSM-xxxPD05.18; TSM-xxxPD14; TSM-xxxDD06M.05(I); TSM-DD06H.08(I); TSM-DD06H.05(I); TSM-DE09C.05; TSM-DE09.05; TSM-DE09.07; TSM-DE09C.07; TSM-DE06X.05(I); TSM-DD06M.05(I); TSM-DE15V(I); TSM-DE15M(I); TSM-DE15H(I); TSM-14H(I); TSM-DE09.08; TSM-NE09RC.05
United Ren. Energy	D6MxxxH3A
URE Co.	FAMxxxE8-BB; FAMxxxE8G-BB; FBMxxxMFG-BB; FAKxxxC8G; FAKxxxE8G; FAMxxxE7G-BB; FBMxxxMFG; FBMxxxM7G-BB
Vikram	VSM DH.66. xxx.05; VSM DH.72. xxx.05; VSM DH.78. xxx.05; VSM DH.72. xxx.05
VSun	VSUN-xxx-108BMH; VSUNxxx-120BMH; VSUNxxx-108M-BB; VSUNxxx-144BMH-DG; VSUNxxxN-108BMH; VSUNxxxN-108MH
Waaree	WSMDI-xxx
Winaico	WSP-xxxM6
Yingli	YLxxxD-30b; YLxxxP-29b
ZNShine	ZXM6-NHLD144; ZXM6-SP150; ZXM6-SP120; ZXM6-SPLD120; ZXM6-NH144; ZXM6-NH132; ZXM6-NH120; ZXM7-SPLD144; ZXM6-NHLD120; ZXM6-NHLD132; ZXM7-SH108





ButyL-FOOT

1/2" Drive Fasteners

Use one tool for the entire Pegasus Rail System installation

Optional Deck Attach Method

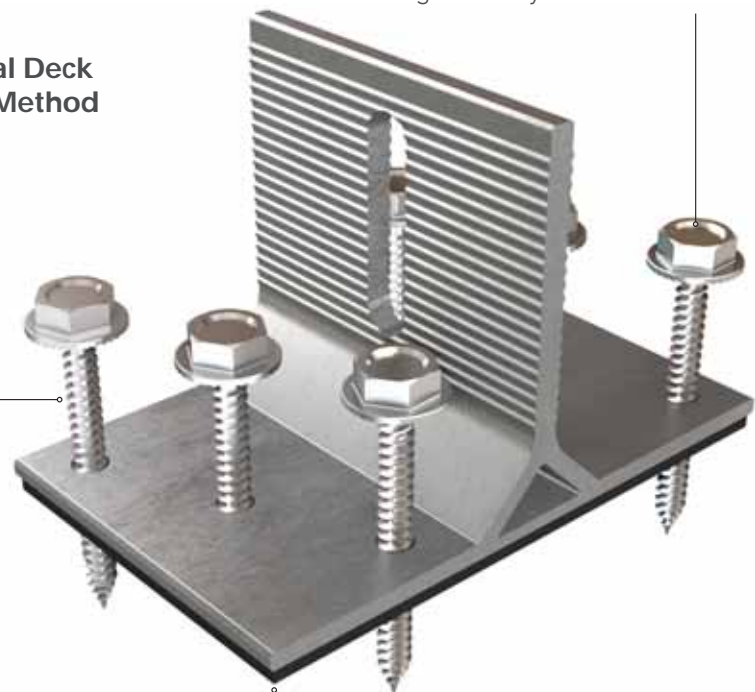

Extra Thick Butyl Tape

Conforms to un-even shingles

Simple Deck Attach Solution for Composite Roofs

The ButyL-Foot is a cost-effective solution to mount rails to composition shingle roofs. Pegasus' proprietary dual-purpose deck and rafter fasteners provide superior strength compared to standard screws.



25-Year Warranty

Manufactured with advanced materials and coatings to outlast the roof itself



Code Compliant

Fully IBC/CBC Code Compliant Exceeds ASCE 7-16 Standards UL2703 Certified



Mechanical Attachment

Extra Strength Proprietary fastener design increases pull-out strength



Universal Fit

Universal Use Installs into Rafters or Decking

Pegasus Solar Inc | 506 West Ohio Avenue, Richmond, CA 94804 | www.pegasussolar.com



ButyL-FOOT

1 Avoid installation when the temperature is below 32F or above 150F. ButyL-Foot must be installed on a dry surface. Remove liner on butyl tape.

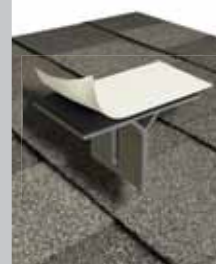

2 Shingle Joints Avoid placing the ButyL-Foot directly over the joint between shingle sheets ("butt joints"). If unavoidable, fill butt joint up to the above shingle course with approved sealant.



Shingle Tabs If the shingle tab height difference is more than 1/8inch, add in a spare shingle tab to level the ButyL-Foot. **Do not install fasteners in the gap between the shingle tabs.**



3 Rafter Attach Align ButyL-Foot with marked Rafter, and install 2 screws into rafter.



Rafter Attach If Rafter is missed with 1st screw, install 2nd and 3rd screws into rafter using either the right or left pair of holes. **Do not strip the wood.**



Deck Attach Install all 6 screws until snug. **Do not strip the wood.** Check ButyL-Foot Span Tables for appropriate span between mounts.

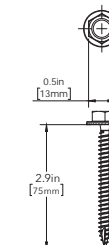
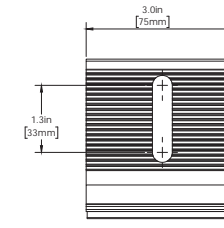
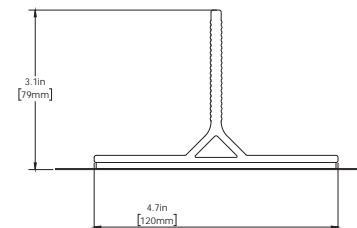
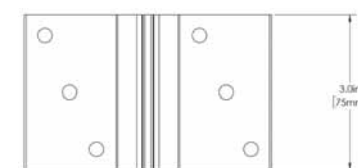

ButyL-FOOT	PBF-MDT
Finish	Mill
Kit Contents	Mill ButyL-foot, Pegasus Deck Fasteners, Dovetail T-bolt w/ Nut
Attachment Type	Deck or Rafter Attached
Roof Type	Composition Shingle
Waterproofing	Extra-thick Butyl Tape; Instantly Waterproof
Temperature Range	32°F to 150°F
Certifications	IBC, CBC, ASCE 7-16, UL2703 Certified
Kit Quantity	24 ButyL-Feet, 25 Dovetail T-bolts, 70 Pegasus Roof Screws

All rights reserved. ©2023 Pegasus Solar Inc. See www.PS-IP.com for intellectual property details.

Failure to follow the exact installation instructions will void the Pegasus Solar Warranty.

Pegasus Solar Inc | 506 West Ohio Avenue, Richmond, CA 94804 | www.pegasussolar.com



DRAWING TITLE:

SPEC SHEET

DRAWING NUMBER:

SS