

SCOPE OF WORK

INSTALL A ROOF-MOUNTED PV SYSTEM :

- (24) CERTAINTED CT370HC11-06 MODULES
- (8) TESLA SOLAR SHUTDOWN DEVICES
- (02) TESLA POWERWALL 3 (11.5KW, 13.5KWH)
- (01) TESLA GATEWAY 2
- (01) FUSED AC DISCONNECT

TOTAL PV SIZE: 8.88KW DC, 20.000KW CEC AC

GOVERNING CODES

- ALL WORK TO COMPLY WITH:
- 2018 INTERNATIONAL BUILDING CODE
 - 2018 INTERNATIONAL RESIDENTIAL CODE
 - 2017 NATIONAL ELECTRICAL CODE
 - 2013 INTERNATIONAL FIRE CODE

SITE PLAN

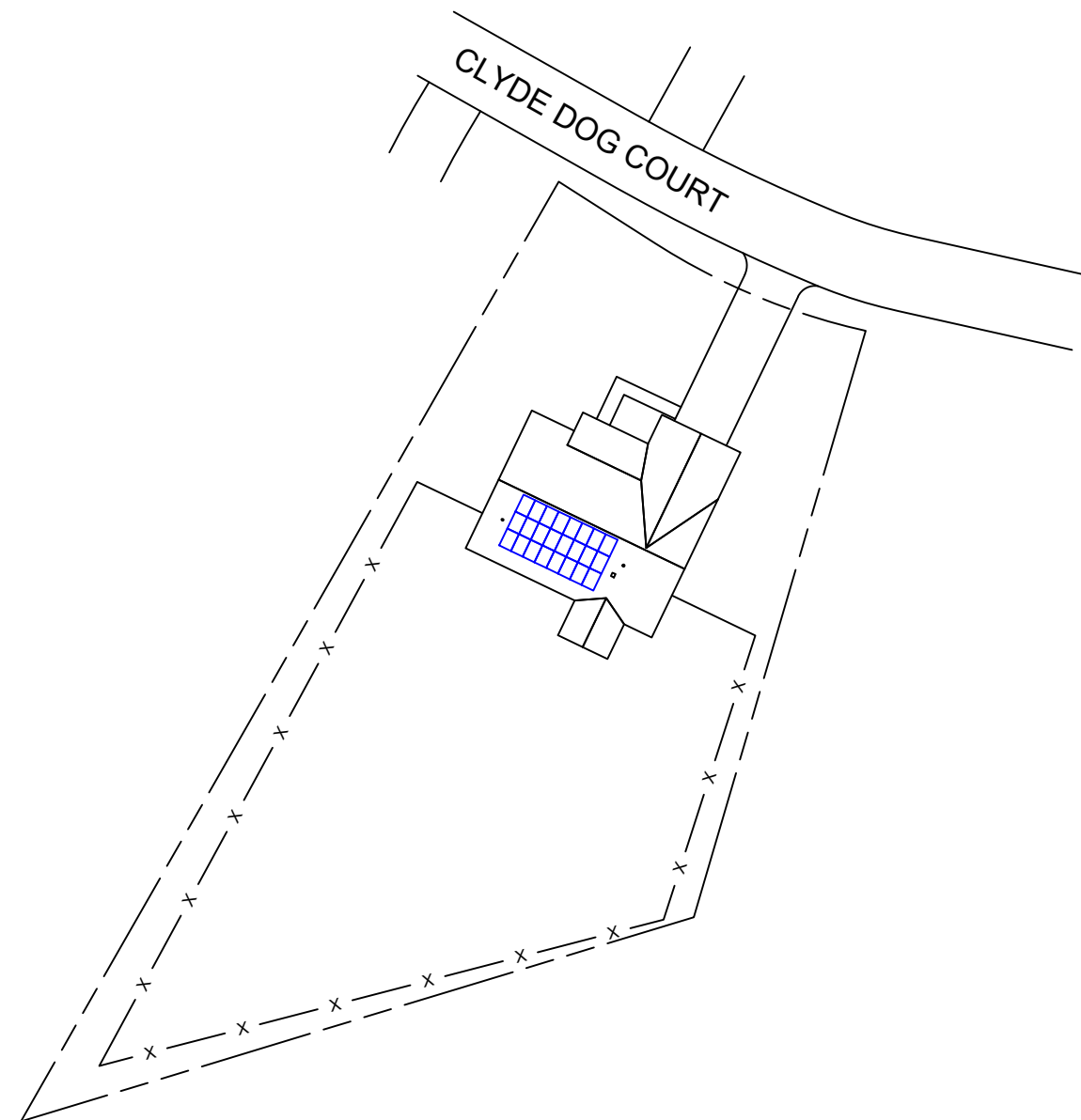

TABLE OF CONTENTS

PV-1	COVER SHEET
PV-2	ROOF PLAN & MODULES
PV-2A	ROOF, MODULES & ATTACHMENT DETAILS
PV-3A	STRINGING PAGE
PV-4	SINGLE-LINE DIAGRAM
PV-4A	DESIGN TABLES
PV-5	LABELS & PLACARD
PV-6+	EQUIPMENT DATASHEETS
PV-12	MAPPING SHEET

GENERAL NOTES

- ALL WORK SHALL CONFORM TO APPLICABLE BUILDING, ELECTRICAL CODE AND ANY LOCALLY ADOPTED ORDINANCES.
- DRAWINGS ARE DIAGRAMMATIC, SITE CONDITIONS SHALL PREVAIL. IF NO SCALE IS GIVEN, DRAWINGS ARE NOT TO SCALE. ALL DIMENSIONS SHALL BE VERIFIED BY THE CONTRACTOR IN THE FIELD UPON COMMENCEMENT OF CONSTRUCTION.
- ALL CONDUIT AND WIRE RUNS ARE DIAGRAMMATIC, SUBJECT TO FIELD CONDITIONS ROUTING OF RACEWAYS SHALL BE FINALIZED BY THE CONTRACTOR. IF THE DISTANCES FOR WIRE RUNS ARE DIFFERENT THAN AS SHOWN, THE CONTRACTOR SHALL NOTIFY THE DESIGN TEAM TO VALIDATE THE WIRE SIZE.
- ALL EQUIPMENT SHALL BE LISTED AND LABELED BY A RECOGNIZED TESTING LABORATORY AND INSTALLED PER THE LISTING AND MANUFACTURER'S REQUIREMENTS.
- ALL EQUIPMENT SHALL BE INSTALLED IN ACCORDANCE WITH REQUIRED ACCESS AND WORKING CLEARANCES PER CEC ARTICLE 110.
- ALL NEW MAIN SERVICE PANELS AND SUBPANELS WILL HAVE APPROPRIATE FIELD IDENTIFICATION PER CEC 408.4.
- ALL EQUIPMENT WILL BE INSTALLED WHERE IT IS NOT EXPOSED TO PHYSICAL DAMAGE PER CEC110.27(B).

AERIAL PHOTO



SITE DETAILS

ASHRAE MIN TEMP	-11.1°C
ASHRAE 2% HIGH TEMP	37.1°C
BUILDING OCCUPANCY	R-3
TYPE OF CONSTRUCTION	V-B
SPRINKLERS SYSTEM PER NFPA 13D	NO
# OF STORIES	1
WIND SPEED (ASCE 7-10)	115 MPH
WIND EXPOSURE	B
RISK CATEGORY	II
GROUND SNOW LOAD	15 LBS
SQUARE FOOTAGE	-- SQ FT
UTILITY PROVIDER	DUKE ENERGY



0 24' 48'

RENU ENERGY SOLUTIONS, LLC
 801 PRESSLEY ROAD, SUITE 100
 CHARLOTTE, NORTH CAROLINA, 28217
 704-525-6767 | RENUENERGYSOLUTIONS.COM

NC GC #76615
 NC ELE #U.34519

PREPARED BY:
 RENU ENERGY SOLUTIONS
 LEVI JOHNSON

SCALE: 1/48" = 1'-0"

SHEET SIZE: 11" x 17"

TEMPLATE V2.0

AHJ: HARNETT COUNTY

APN: 0539-71-5559.000

DATE: 09/09/2024

NICOLE THOMPSON
 185 CLYDE DOG COURT
 LILLINGTON, NC 27546

PV-1
 COVER SHEET

PV ROOF COVERAGE				
(E) PV AREA [SQ FT]	(N) PV AREA [SQ FT]	TOTAL PV AREA [SQ FT]	TOTAL ROOF AREA [SQ FT]	PERCENTAGE COVERED BY PV
0	485.20	485.20	3374	14%

LEGEND
○ □ - ROOF OBSTRUCTION

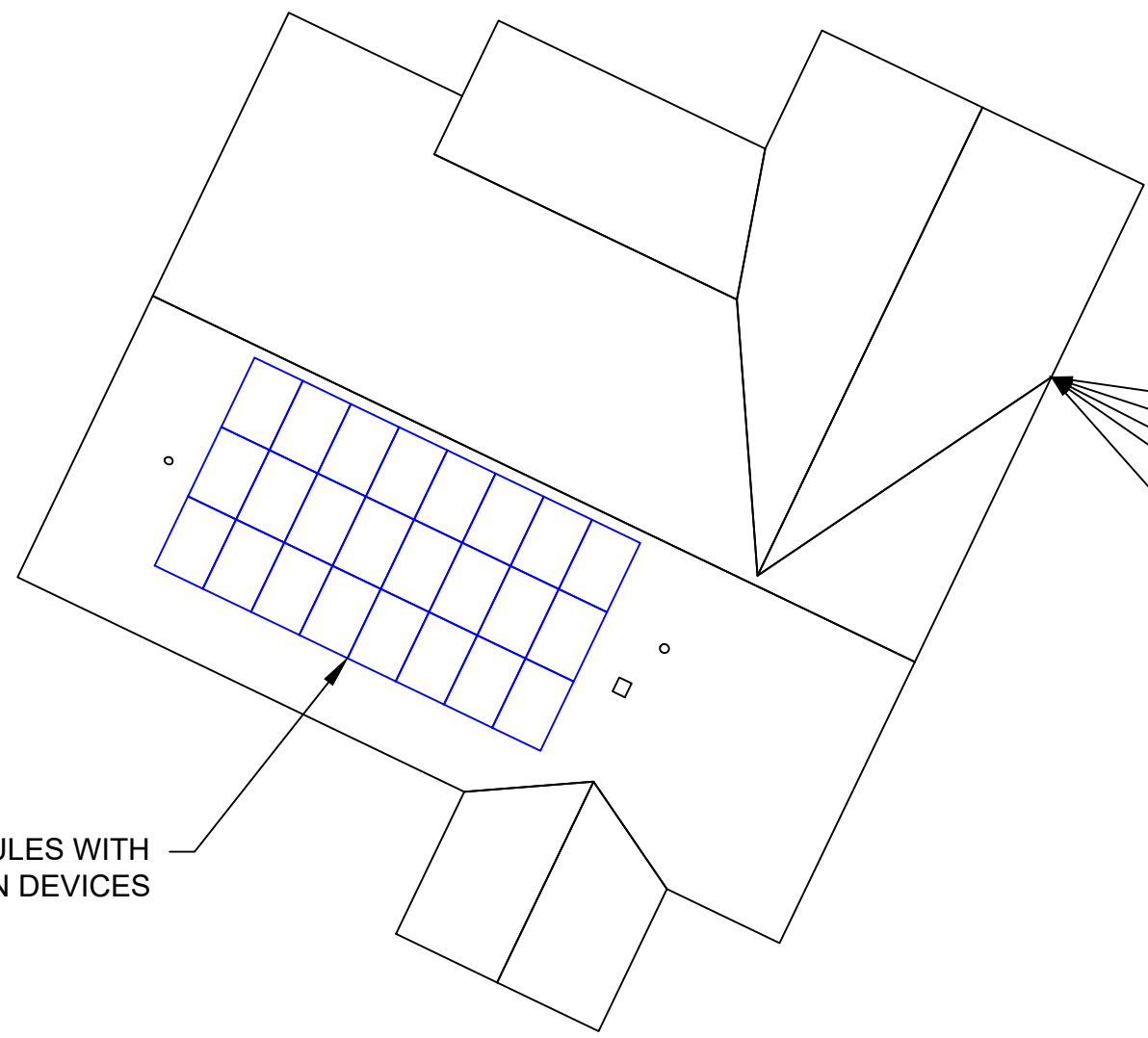

- EXTERIOR PV EQUIPMENT
- (E)(1) UTILITY METER
- (N)(1) AC DISCONNECT
- (N)(2) TESLA POWERWALL 3
- (N)(1) TESLA BACKUP GATEWAY
- INTERIOR PV EQUIPMENT
- (E)(1) PROTECTED LOADS PANEL

(24) CERTAINTEED CT370HC11-06 MODULES WITH
(8) TESLA SOLAR SHUTDOWN DEVICES

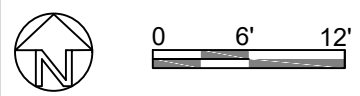

RENU ENERGY SOLUTIONS, LLC
 801 PRESSLEY ROAD, SUITE 100
 CHARLOTTE, NORTH CAROLINA, 28217
 704-525-6767 | RENUENERGYSOLUTIONS.COM

NC GC #76615
 NC ELE #U.34519

PREPARED BY:
 RENU ENERGY SOLUTIONS
 LEVI JOHNSON



SCALE: 1/12" = 1'-0"
 SHEET SIZE: 11" x 17"
 TEMPLATE V2.0

AHJ: HARNETT COUNTY
 APN: 0539-71-5559.000
 DATE: 09/09/2024

NICOLE THOMPSON
 185 CLYDE DOG COURT
 LILLINGTON, NC 27546

PV-2
 ROOF PLAN
 & MODULES

LEGEND	
---	- RAFTER OR TRUSS
●	- ROOF ATTACHMENT

(N) SNAPNRACK UR-40 RAIL

(36) SNAPNRACK ANCHORFOOT ATTACHMENTS WITH MAX 72" O.C. SPAN

ROOF #1

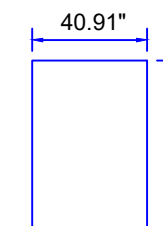
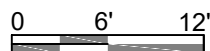
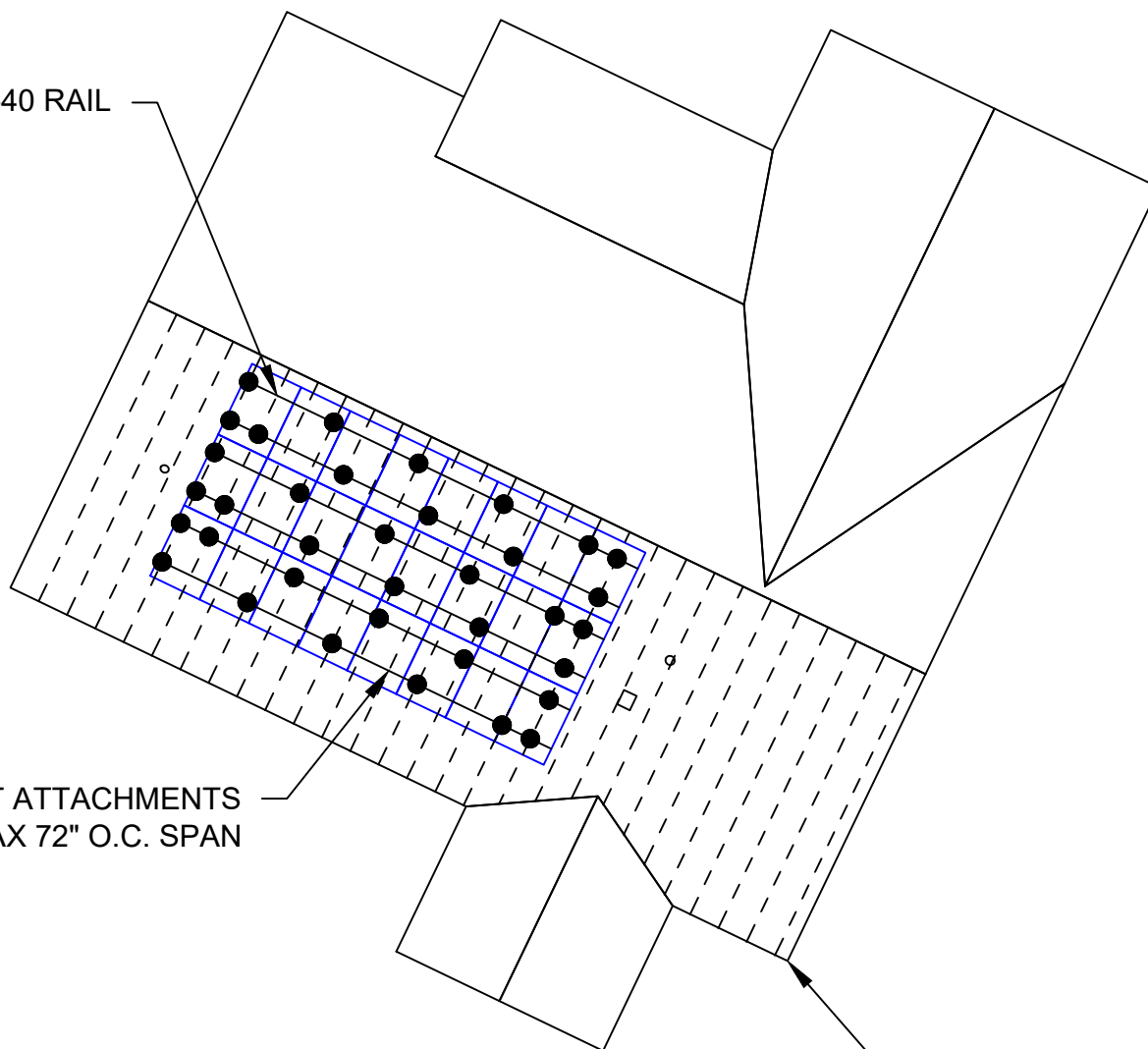

MODULE : CERTAINTED CT370HC11-06 (370W)

ROOF DESCRIPTION

ROOF #	ROOF TILT	AZIMUTH	ROOF MATERIAL	TRUSS SIZE	TRUSS SPACING	MAX SPAN
#1	31°	206°	HIGH-DEF COMPOSITION	2" X 6"	24" O.C.	126"

STRUCTURAL INFORMATION

NUMBER OF MODULES	24	--
MODULE WEIGHT	45.19	LBS
TOTAL MODULE (ARRAY) WEIGHT	1084.56	LBS
NUMBER OF ATTACHMENT POINT	36	--
MOUNTING SYSTEM WEIGHT (PER MODULE)	0.55	LBS
MOUNTING SYSTEM WEIGHT	19.80	LBS
TOTAL SYSTEM WEIGHT	1104.36	LBS
WEIGHT AT EACH ATTACHMENT POINT	30.13	LBS
MODULE AREA (69.13"X40.91")	19.64	SQFT
TOTAL ARRAY AREA	485.20	SQFT
DISTRIBUTED LOAD	2.28	PER SQFT

ROOF ATTACHMENT DETAIL

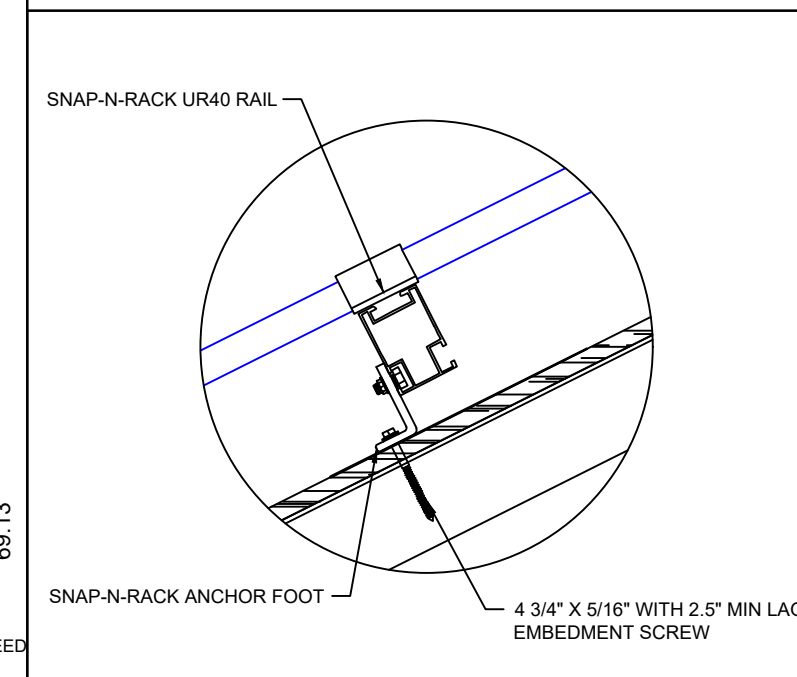

RENU ENERGY SOLUTIONS, LLC

801 PRESSLEY ROAD, SUITE 100
CHARLOTTE, NORTH CAROLINA, 28217
704-525-6767 | RENUENERGYSOLUTIONS.COM

NC GC #76615
NC ELE #U.34519

PREPARED BY:
RENU ENERGY SOLUTIONS
LEVI JOHNSON

SCALE: 1/12" = 1'-0"

SHEET SIZE: 11" x 17"

TEMPLATE V2.0

AHJ: HARNETT COUNTY

APN: 0539-71-5559.000

DATE: 09/09/2024

NICOLE THOMPSON

185 CLYDE DOG COURT
LILLINGTON, NC 27546

PV-2A
ROOF, MODULES
& ATTACHMENT
DETAILS

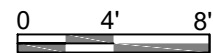
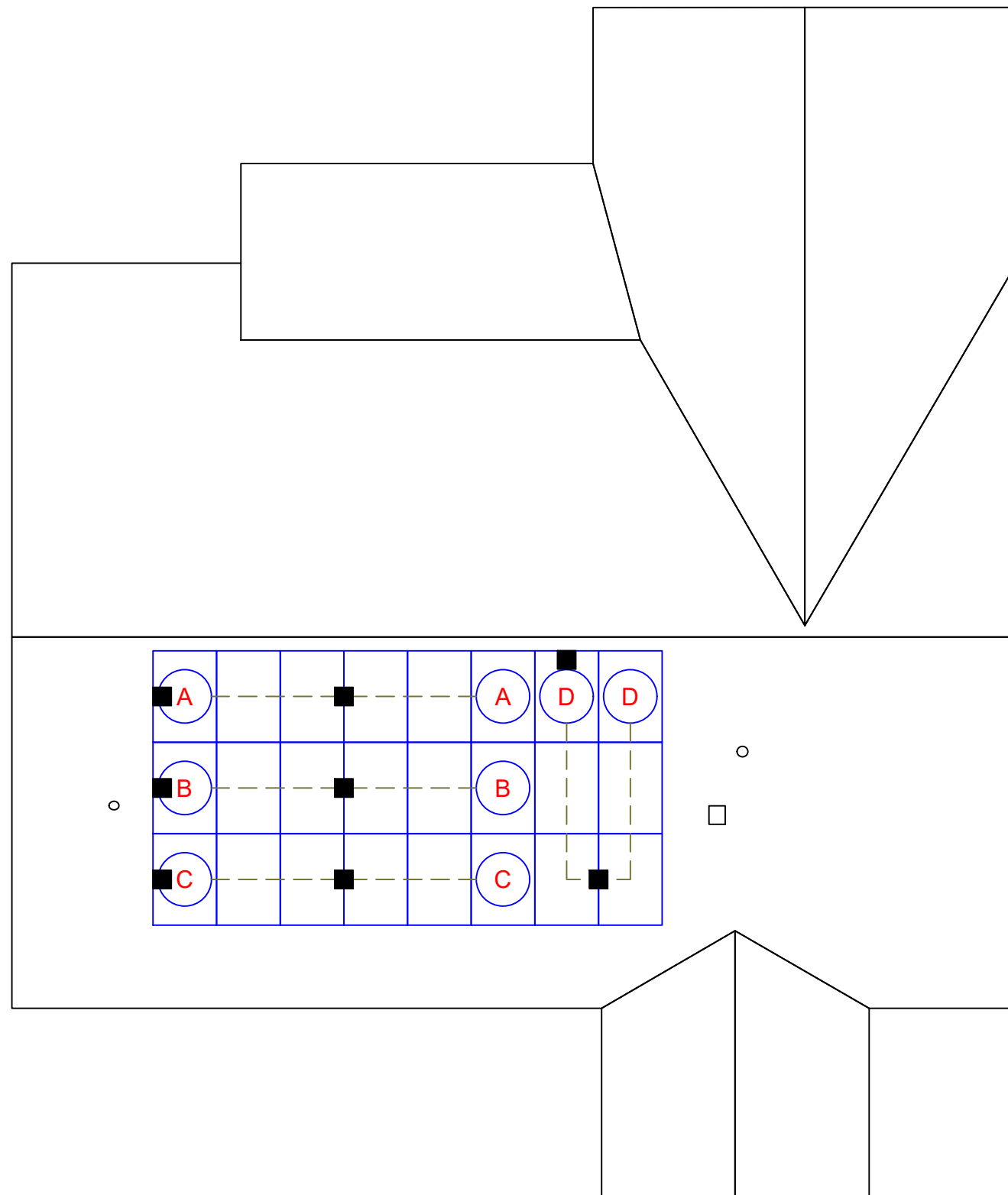

RENU ENERGY SOLUTIONS, LLC

801 PRESSLEY ROAD, SUITE 100
 CHARLOTTE, NORTH CAROLINA, 28217
 704-525-6767 | RENUENERGYSOLUTIONS.COM

NC GC #76615
 NC ELE #U.34519

PREPARED BY:
 RENU ENERGY SOLUTIONS
 LEVI JOHNSON

SCALE: 1/8" = 1'-0"

SHEET SIZE: 11" x 17"

TEMPLATE V2.0

AHJ: HARNETT COUNTY

APN: 0539-71-5559.000

DATE: 09/09/2024

NICOLE THOMPSON

185 CLYDE DOG COURT
 LILLINGTON, NC 27546

PV-3A
 STRINGING
 PAGE

ID	TYPICAL	CONDUCTOR	NEUTRAL	EGC	CONDUIT	CURRENT-CARRYING CONDUCTORS IN CONDUIT	OCPD	TEMP. CORR. FACTOR	CONDUIT FILL FACTOR	CONT. CURRENT	MAX CURRENT (125%)	BASE AMP.	DERATED AMP.	TERM TEMP. RATING	AMP. @ TERMINAL
1	1	4/0 AWG XHHW, ALUMINUM	4/0 AWG XHHW, ALUMINUM	N/A	2" DIA	2	200A	0.96 (35°C)	1	-	200.0A	205A	196.8A	75°C	180A
2	1	4/0 AWG XHHW, ALUMINUM	4/0 AWG XHHW, ALUMINUM	4 AWG XHHW, ALUMINUM	2" DIA	2	N/A	0.96 (35°C)	1	-	200.0A	205A	196.8A	75°C	180A
3	1	1 AWG THHN, COPPER	1 AWG THHN, COPPER	4 AWG XHHW, ALUMINUM	1.25" DIA	2	125A	0.96 (35°C)	1	96.0A	120.0A	145A	139.2A	75°C	130A
4	1	1 AWG THHN, COPPER	1 AWG THHN, COPPER	4 AWG XHHW, ALUMINUM	1.25" DIA	2	125A	0.96 (35°C)	1	96.0A	120.0A	145A	139.2A	75°C	130A
5	1	6 AWG THHN, COPPER	6 AWG THHN, COPPER	10 AWG THHN, COPPER	1" DIA	2	60A	0.96 (35°C)	1	48.0A	60.0A	75A	72.0A	75°C	65A
6	1	10 AWG THHN, COPPER	N/A	2X 10 AWG THHN, COPPER	0.75" DIA	8	N/A	0.96 (35°C)	0.7	10.87A	13.59A	40A	26.88A	75°C	35A
7	1	10 AWG PV WIRE, COPPER	N/A	6 AWG BARE, COPPER	FREE AIR	2	N/A	0.96 (35°C)	1	10.87A	13.59A	55A	52.8A	75°C	50A

NEW SOLAR PROJECT
8.88 KW DC, 20.00 KW AC (THROTTLED)

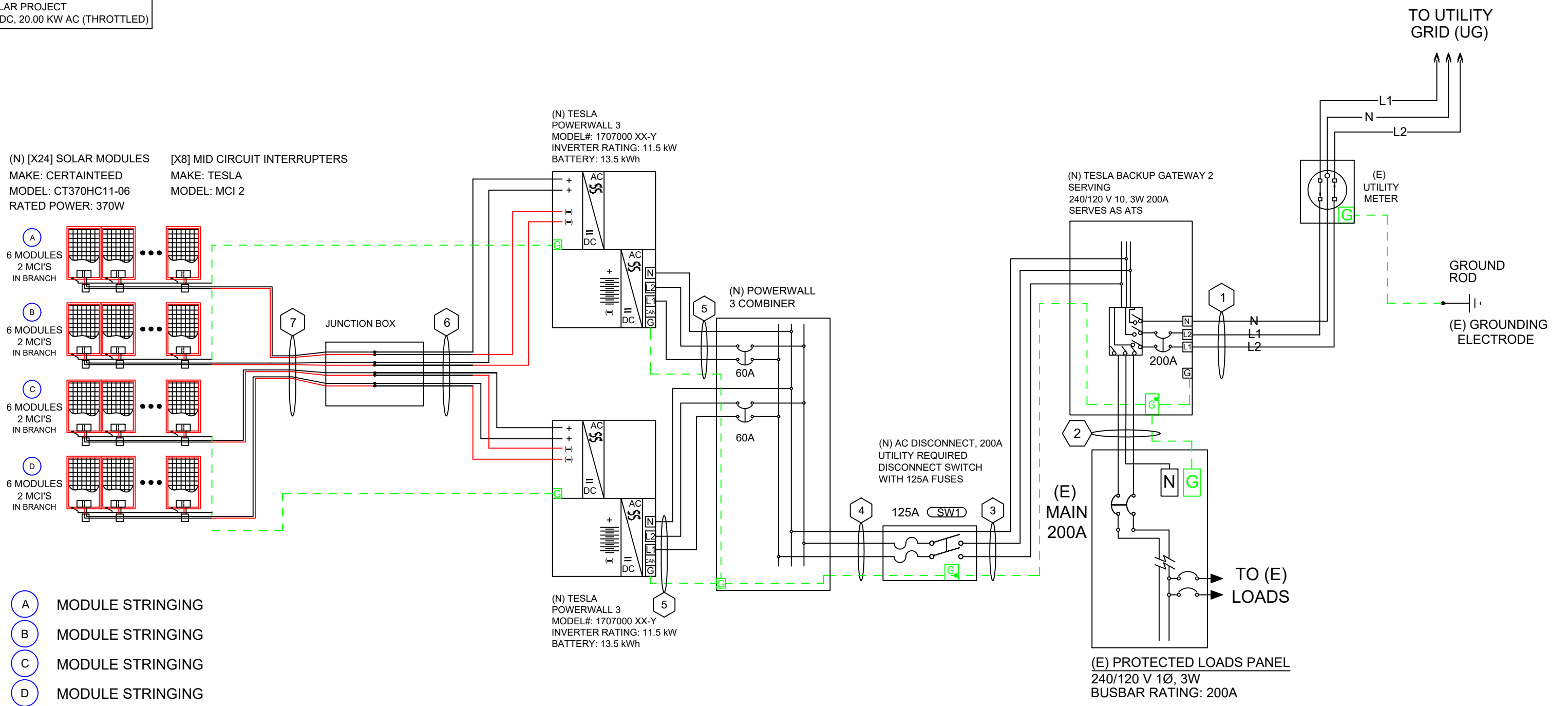

MODULES										
REF.	QTY.	MAKE AND MODEL	PMAX	PTC	ISC	IMP	VOC	VMP	TEMP. COFF. OF VOC	FUSE RATING
(N) PV MODULES	24	CERTAINTED CT370HC11-06	370W	337.80W	11.51A	10.87A	40.8V	34.06V	-0.29%/°C	25A

DISCONNECTS					
REF.	QTY.	MAKE AND MODEL	FUSES	RATED CURRENT	MAX RATED VOLATGE
(N) DISCONNECT	1	EATON OR EQUIVALENT	125A	200A	240 V

INVERTERS											
REF.	QTY.	MAKE AND MODEL	AC VOLTAGE	GROUND	OCPD RATING	RATED POWER	MAX OUTPUT CURRENT	MAX INPUT CURRENT	MAX INPUT VOLTAGE	CEC WEIGHTED EFFICIENCY	
(N) INVERTERS	2	TESLA POWERWALL 3 (240V)	240V	FLOATING	60A	11500W	48.0A	90A	550V	99.0%	

DESIGN TEMPERATURES	
ASHRAE EXTREME LOW	-11.1°C (12.0°F), SOURCE: HARNETT COUNTY (35.38°;-78.73°)
ASHRAE 2% HIGH	37.1°C (98.8°F), SOURCE: HARNETT COUNTY (35.38°;-78.73°)

INVERTER OUTPUT CALCULATIONS & 705.12 COMPLIANCE

INVERTER OUTPUT CIRCUIT	INVERTER OR ESS	# OF INVERTERS / ESS	CONTINUOUS OUTPUT	125% SAFETY FACTOR	TOTAL BACKFEED	MINIMUM BREAKER SIZE
#1	PW3	2	48.00A	125%	120.00A	120A
TOTAL					120.00A	120A

VOC CALCULATION PER NEC 690.7(A)(1)

MODULE	CERTAINTED370
# OF MODULES LARGEST STRING	6
ASHRAE MIN TEMP [°C]	-11.1
VOC [V]	40.8
TEMP COEF VOC [%/°C]	-0.29
TEMP ADJ VOC [V]	45.07
VOLTAGE OF LARGEST STRING [V]	270.42

ELECTRICAL NOTES (APPLICABILITY BASED ON SCOPE OF WORK)

AS-BUILT CHANGES TO THE ABOVE WIRING ARE PERMISSIBLE AS LONG AS SUBSTITUTIONS ARE CODE COMPLIANT. FOR EXAMPLE, APPROPRIATELY SIZED NM-B MAY BE USED FOR MICROINVERTER OUTPUT CIRCUITS IF INSTALLED IN ACCORDANCE WITH NEC ARTICLE 334, OR MC CABLE MAY BE USED FOR DC SOLAR STRINGS IF INSTALLED IN ACCORDANCE WITH NEC ARTICLE 330.

ALL OUTDOOR EQUIPMENT SHALL BE RAIN-TIGHT & HOLD A MINIMUM NEMA 3R RATING, INCLUDING ALL ROOF MOUNTED TRANSITION BOXES AND SWITCHES. CONDUCTORS EXPOSED TO WET CONDITIONS SHALL BE SUITABLE FOR USE IN WET CONDITIONS PER NEC 310.10(C).

ALL TERMINAL TEMPERATURES OF EQUIPMENT WILL BE VERIFIED TO BE RATED FOR 75°C, OR THE WIRE WILL NEED TO BE RESIZED USING THE 60°C TERMINAL TEMPERATURE RATINGS FOR 100A OR LESS.

ALL NM-B SHALL BE INSTALLED AND PROTECTED PER NEC 334, AND ALL SER CABLE SHALL BE INSTALLED AND PROTECTED PER NEC 338.

ALL ROOFTOP RACEWAYS AND CABLES EXPOSED TO DIRECT SUNLIGHT WILL BE INSTALLED >7/8" ABOVE THE ROOF.

ALL EQUIPMENT SHALL BE PROPERLY GROUNDED AND BONDED IN ACCORDANCE WITH NEC ARTICLE 250. A SUPPLEMENTAL GROUND ROD WILL BE DRIVEN IN ACCORDANCE WITH NEC 250.53(A)(3) IF THE EXISTING GROUND ROD HAS A RESISTANCE TO EARTH THAT IS GREATER THAN 25 OHMS.

IF ANY EXISTING LOAD CONDUCTORS ARE EXTENDED BY MORE THAN 6', AFCI PROTECTION WILL BE PROVIDED PER NEC 210.12(D).

PER NEC 690.47(A) PV SYSTEMS THAT ARE NOT SOLIDLY GROUNDED, THE EQUIPMENT GROUNDING CONDUCTOR FOR THE OUTPUT OF THE PV SYSTEMS SHALL BE PERMITTED TO BE THE CONNECTION TO GROUND FOR GROUND-FAULT PROTECTION AND EQUIPMENT GROUNDING OF THE PV ARRAY.

THE ESS CIRCUIT BREAKER SHALL BE SECURED IN PLACE BY AN ADDITIONAL FASTENER PER NEC 408.36(D).

NO SINGLE BACK-UP LOAD WILL BE LARGER THAN THE MAXIMUM CONTINUOUS OUTPUT OF THE ESS PER NEC 710.15(A).



RENU ENERGY SOLUTIONS, LLC
 801 PRESSLEY ROAD, SUITE 100
 CHARLOTTE, NORTH CAROLINA, 28217
 704-525-6767 | RENUENERGYSOLUTIONS.COM

NC GC #76615
 NC ELE #U.34519

PREPARED BY:
 RENU ENERGY SOLUTIONS
 LEVI JOHNSON



SCALE: NTS
 SHEET SIZE: 11" x 17"
 TEMPLATE V2.0

AHJ: HARNETT COUNTY
 APN: 0539-71-5559.000
 DATE: 09/09/2024

NICOLE THOMPSON
 185 CLYDE DOG COURT
 LILLINGTON, NC 27546

PV-4A
 DESIGN TABLES

SOLAR PV SYSTEM EQUIPPED WITH RAPID SHUTDOWN

TURN RAPID SHUTDOWN SWITCH TO THE "OFF" POSITION TO SHUTDOWN PV SYSTEM AND REDUCE SHOCK HAZARD IN ARRAY

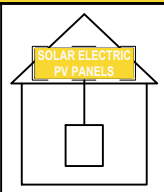

LABEL 1
AT RAPID SHUTDOWN SYSTEM
[NEC 690.56(C)(1)(A)].

WARNING
ELECTRIC SHOCK HAZARD

TERMINALS ON THE LINE AND LOAD SIDES MAY BE ENERGIZED IN THE OPEN POSITION

LABEL 2
AT EACH DISCONNECTING MEANS FOR PHOTOVOLTAIC EQUIPMENT
[NEC 690.15]

ALL SIGNAGE MUST BE PERMANENTLY ATTACHED AND BE WEATHER RESISTANT/SUNLIGHT RESISTANT AND CANNOT BE HAND-WRITTEN PER NEC 110.21(B)

WARNING
ELECTRIC SHOCK HAZARD

THE DC CONDUCTORS OF THIS PHOTOVOLTAIC SYSTEM ARE UNGROUNDED AND MAY BE ENERGIZED

LABEL 3
AT POINT OF INTERCONNECTION; LABEL, SUCH AS LABEL 4 OR LABEL 5 MUST IDENTIFY PHOTOVOLTAIC SYSTEM [NEC 705.12(B)(4)]

PHOTOVOLTAIC SYSTEM
DC DISCONNECT

OPERATING VOLTAGE: 240 VDC
OPERATING CURRENT: 48.00 A
MAX SYSTEM VOLTAGE: 480 VDC
SHORT CIRCUIT CURRENT: 45 A
CHARGE CONTROLLER MAX: N/A

LABEL 4
AT EACH DC DISCONNECTING MEANS
[NEC 690.53]

PHOTOVOLTAIC SYSTEM
AC DISCONNECT

RATED AC OUTPUT CURRENT: 96.00AAC
NOMINAL OPERATING VOLTAGE: 240/480 V AC

LABEL 5
AT EACH DISCONNECTING MEANS FOR PHOTOVOLTAIC EQUIPMENT
[NEC 690.15]

WARNING
DUAL POWER SUPPLY

SOURCES: UTILITY GRID AND PV SOLAR ELECTRIC SYSTEM

LABEL 6
AT POINT OF INTERCONNECTION; LABEL, SUCH AS LABEL 4 OR LABEL 5 MUST IDENTIFY PHOTOVOLTAIC SYSTEM [NEC 705.12(B)(4)]

WARNING
INVERTER OUTPUT CONNECTION

DO NOT RELOCATE THIS OVERCURRENT DEVICE

LABEL 7
AT POINT OF INTERCONNECTION; LABEL, SUCH AS LABEL 4 OR LABEL 5 MUST IDENTIFY PHOTOVOLTAIC SYSTEM [NEC 705.12(B)(4)]

WARNING: PHOTOVOLTAIC POWER SOURCE

LABEL 8
AT EXPOSED RACEWAYS, CABLE TRAYS, AND OTHER WIRING METHODS; SPACED AT MAXIMUM 10 FT SECTION OR WHERE SEPARATED BY ENCLOSURES, WALLS, PARTITIONS, CEILINGS, OR FLOORS.
[NEC 690.31(G)]
LETTERS AT LEAST 3/8 INCH; WHITE ON RED BACKGROUND; REFLECTIVE
[IFC 605.11.1.1]

RAPID SHUTDOWN PV ARRAY

LABEL 8
AT RAPID SHUTDOWN SWITCH
[NEC 690.56(C)].
LETTERS AT LEAST 3/8 INCH; WHITE ON RED BACKGROUND; REFLECTIVE
[IFC 605.11.1.1]

DIRECTORY

PERMANENT PLAQUE OR DIRECTORY PROVIDING THE LOCATION OF THE SERVICE DISCONNECTING MEANS AND THE PHOTOVOLTAIC SYSTEM DISCONNECTING MEANS IF NOT IN THE SAME LOCATION [NEC 690.56(B)] WHERE THE PV SYSTEMS ARE REMOTELY LOCATED FROM EACH OTHER, A DIRECTORY IN ACCORDANCE WITH 705.10 SHALL BE PROVIDED AT EACH PV SYSTEM DISCONNECTING MEANS. PV SYSTEM EQUIPMENT AND DISCONNECTING MEANS SHALL NOT BE INSTALLED IN BATHROOMS [NEC 690.4(D),(E)]

LABELING NOTES

- 1.1 LABELING REQUIREMENTS BASED ON THE 2017 NATIONAL ELECTRICAL CODE, INTERNATIONAL FIRE CODE 605.11, OSHA STANDARD 1910.145, ANSI Z535
- 1.2 MATERIAL BASED ON THE REQUIREMENTS OF THE AUTHORITY HAVING JURISDICTION.
- 1.3 LABELS TO BE OF SUFFICIENT DURABILITY TO WITHSTAND THE ENVIRONMENT INVOLVED.
- 1.4 LABELS TO BE A MINIMUM LETTER HEIGHT OF 3/8" AND PERMANENTLY AFFIXED.
- 1.5 ALERTING WORDS TO BE COLOR CODED. "DANGER" WILL HAVE RED BACKGROUND; "WARNING" WILL HAVE ORANGE BACKGROUND; "CAUTION" WILL HAVE YELLOW BACKGROUND. [ANSI Z535]

CertainTeed Solar

CT SERIES 120 HALF-CELL SOLAR MODULES

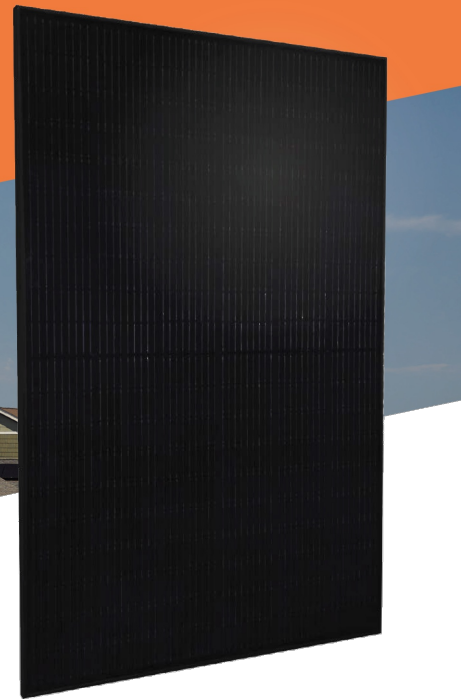

Half-Cell Monocrystalline Type

CT360HC11-06
CT365HC11-06
CT370HC11-06

Features and Benefits

High Quality / High Power

- Up to 370W with black backsheet
- UL listed (UL 61730)
- Positive power output tolerance

Limited Warranty*

- 25-year linear power output warranty

*See CertainTeed's limited warranty for details



See reverse for product specifications

Power Output Warranty

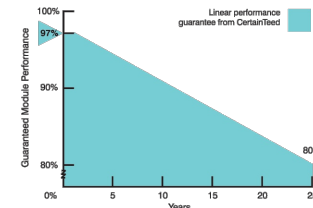

Electrical Characteristics		360W	365W	370W
Nominal Output (Pmpp)	W	360	365	370
Voltage at Pmax (Vmpp)	V	33.8	33.96	34.06
Current at Pmax (Impp)	A	10.66	10.75	10.87
Open Circuit Voltage (Voc)	V	40.6	40.7	40.8
Short Circuit Current (Isc)	A	11.24	11.36	11.51
Output Tolerance	W	-0 / +5		
No. of Cells & Connections	120 half-cells with 3 bypass diodes			
Maximum Series Fuse Rating	20A			
Cell Type	Monocrystalline			
Module Efficiency	%	19.73	20.01	20.29
Temperature Coefficient of Pmpp	%/C	-0.36		
Temperature Coefficient of Voc	%/C	-0.29		
Temperature Coefficient of Isc	%/C	0.05		

Mechanical Characteristics

Laminate	Glass: 3.2 high transmission, tempered, anti-reflective Encapsulant: POE Backsheet: Weatherproof film (Black)
Frame	Anodized aluminum (Black)
Junction Box	IP68
Output Cables	4 mm ² (12AWG) PV Wire, Length 1.2m (47.2")
Connectors	Polarized MC compatible
Weight	20.5 kg (45.19 lbs)

Dimensions

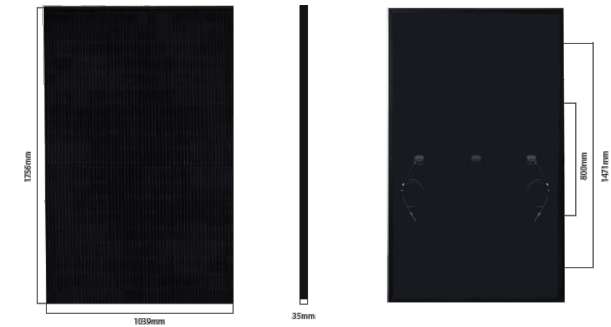

Operating Conditions

Nominal Operating Cell Temp.	44+/-2° C
Operating Temperature	-40 to 85° C
Maximum System Voltage	1,500V
Fire Performance	Class C / Type 1
Maximum Wind Load	210mph wind speed(5400 Pa)
Maximum Snow Load	112 lbs/ft ² (5400 Pa)

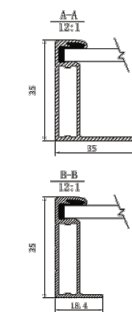

CertainTeed

CEILING • DECKING • FENCE • GYPSUM • INSULATION • RAILING • ROOFING • SIDING • TRIM
20 Moores Road Malvern, PA 19355 Professional: 800-233-8990 Consumer: 800-782-8777 certainteed.com

© 2/20 CertainTeed, Printed in the USA, Code No. PV-01-020



RENU ENERGY SOLUTIONS, LLC

801 PRESSLEY ROAD, SUITE 100
CHARLOTTE, NORTH CAROLINA, 28217
704-525-6767 | RENUENERGYSOLUTIONS.COM

NC GC #76615
NC ELE #U.34519

PREPARED BY:
RENU ENERGY SOLUTIONS
LEVI JOHNSON

SCALE: NTS

SHEET SIZE: 11" x 17"

TEMPLATE V2.0

AHJ: HARNETT COUNTY

APN: 0539-71-5559.000

DATE: 09/09/2024

NICOLE THOMPSON

185 CLYDE DOG COURT
LILLINGTON, NC 27546

PV-6

EQUIPMENT
DATASHEET

Powerwall 3 Technical Specifications

System Technical Specifications	Model Number	1707000-xx-y
	Nominal Grid Voltage (Input & Output)	120/240 VAC
	Grid Type	Split phase
	Frequency	60 Hz
	Overcurrent Protection Device	Configurable up to 60 A
	Solar to Battery to Home/Grid Efficiency	89% ^{1,2}
	Solar to Home/Grid Efficiency	97.5% ³
	Supported Islanding Devices	Backup Gateway 2, Backup Switch
	Connectivity	Wi-Fi (2.4 and 5 GHz), Dual-port switched Ethernet, Cellular (LTE/4G ⁴)
	Hardware Interface	Dry contact relay, Rapid Shutdown (RSD) certified switch and 2-pin connector, RS-485 for meters
	AC Metering	Revenue Grade (+/- 0.5%)
	Protections	Integrated arc fault circuit interrupter (AFCI), Isolation Monitor Interrupter (IMI), PV Rapid Shutdown (RSD) using Tesla Mid-Circuit Interrupters
	Customer Interface	Tesla Mobile App
Warranty	10 years	

Solar Technical Specifications	Maximum Solar STC Input	20 kW
	Withstand Voltage	600 V DC
	PV DC Input Voltage Range	60 — 550 V DC
	PV DC MPPT Voltage Range	150 — 480 V DC
	MPPTs	6
	Maximum Current per MPPT (I_{mp})	13 A ⁵
	Maximum Short Circuit Current per MPPT (I_{sc})	15 A ⁵

Battery Technical Specifications	Nominal Battery Energy	13.5 kWh AC ²
	Maximum Continuous Discharge Power	11.5 kW AC
	Maximum Continuous Charge Power	5 kW AC
	Output Power Factor Rating	0 - 1 (Grid Code configurable)
	Maximum Continuous Current	48 A
	Maximum Output Fault Current	10 kA
	Load Start Capability (1 s)	185 A LRA
	Power Scalability	Up to 4 Powerwall 3 units supported

¹Typical solar shifting use case.
²Values provided for 25°C (77°F), at beginning of life. 3.3 kW charge/discharge power.
³Tested using CEC weighted efficiency methodology.
⁴Cellular connectivity subject to network service coverage and signal strength.
⁵Where the DC input current exceeds the MPPT rating, a jumper can be used to combine two MPPTs into a single input to intake DC current up to 26 A I_{mp} / 30 A I_{sc} .

Powerwall 3 Technical Specifications

Environmental Specifications	Operating Temperature	-20°C to 50°C (-4°F to 122°F) ⁶
	Operating Humidity (RH)	Up to 100%, condensing
	Storage Temperature	-20°C to 30°C (-4°F to 86°F), up to 95% RH, non-condensing, State of Energy (SOE): 25% initial
	Maximum Elevation	3000 m (9843 ft)
	Environment	Indoor and outdoor rated
	Enclosure Rating	NEMA 3R
	Ingress Rating	IPX7 (Battery & Power Electronics) IPX5 (Wiring Compartment)
	Pollution Rating	PD3
	Operating Noise @ 1 m	<50 db(A) typical <62 db(A) maximum

⁶ Performance may be de-rated at operating temperatures above 40°C (104°F).

Compliance Information	Certifications	UL 1642, UL 1699B, UL 1741, UL 1741 SA, UL 1741 SB, UL 3741, UL 1973, UL 1998, UL 9540, IEEE 1547-2018, IEEE 1547.1, UN 38.3
	Grid Connection	United States
	Emissions	FCC Part 15 Class B
	Environmental	RoHS Directive 2011/65/EU
	Seismic	AC156, IEEE 693-2005 (high)
	Fire Testing	Meets the unit level performance criteria of UL 9540A

Mechanical Specifications	Dimensions	1099 x 609 x 193 mm (43.25 x 24 x 7.6 in)
	Weight	130 kg (287 lb)
	Mounting Options	Floor or wall mount

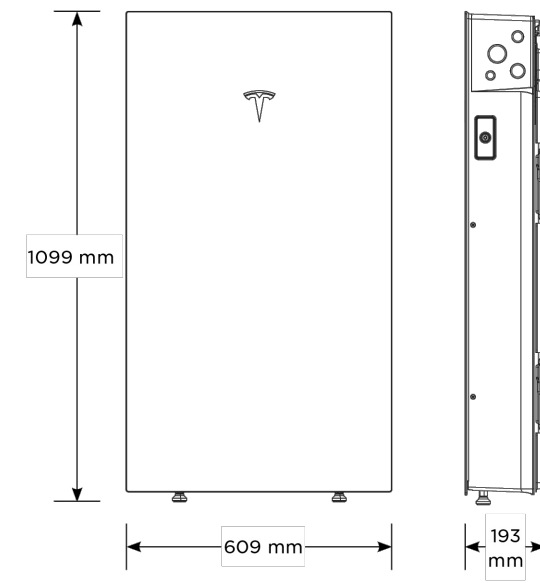

<p>RENU ENERGY SOLUTIONS, LLC 801 PRESSLEY ROAD, SUITE 100 CHARLOTTE, NORTH CAROLINA, 28217 704-525-6767 RENUENERGYSOLUTIONS.COM</p>	<p>NC GC #76615 NC ELE #U.34519</p>	<p>PREPARED BY: RENU ENERGY SOLUTIONS LEVI JOHNSON</p>	SCALE: NTS	AHJ: HARNETT COUNTY	<p>NICOLE THOMPSON 185 CLYDE DOG COURT LILLINGTON, NC 27546</p>	<p>PV-7 EQUIPMENT DATASHEET</p>
			SHEET SIZE: 11" x 17"	APN: 0539-71-5559.000		
			TEMPLATE V2.0	DATE: 09/09/2024		

SOLAR SHUTDOWN DEVICE

The Tesla Solar Shutdown Device is a Mid-Circuit Interrupter (MCI) and is part of the PV system rapid shutdown (RSD) function in accordance with Article 690 of the applicable NEC. When paired with the Tesla Solar Inverter, solar array shutdown is initiated by any loss of AC power.



ELECTRICAL SPECIFICATIONS

Model Number	MCI-1
Nominal Input DC Current Rating (I_{mp})	12 A
Maximum Input Short Circuit Current (I_{sc})	15 A
Maximum System Voltage	600 V DC

RSD MODULE PERFORMANCE

Maximum Number of Devices per String	5
Control	Power Line Excitation
Passive State	Normally open
Maximum Power Consumption	7 W
Warranty	25 years

COMPLIANCE INFORMATION

Certifications	UL 1741 PVRSE, UL 3741, PVRSA (Photovoltaic Rapid Shutdown Array)
RSD Initiation Method	PV System AC Breaker or Switch
Compatible Equipment	See Compatibility Table below

ENVIRONMENTAL SPECIFICATIONS

Ambient Temperature	-40°C to 50°C (-40°F to 122°F)
Storage Temperature	-30°C to 70°C (-22°F to 158°F)
Enclosure Rating	NEMA 4 / IP65

MECHANICAL SPECIFICATIONS

Electrical Connections	MC4 Connector
Housing	Plastic
Dimensions	125 mm x 150 mm x 22 mm (5 in x 6 in x 1 in)
Weight	350 g (0.77 lb)
Mounting Options	ZEP Home Run Clip M4 Screw (#10) MB Bolt (5/16") Nail / Wood screw

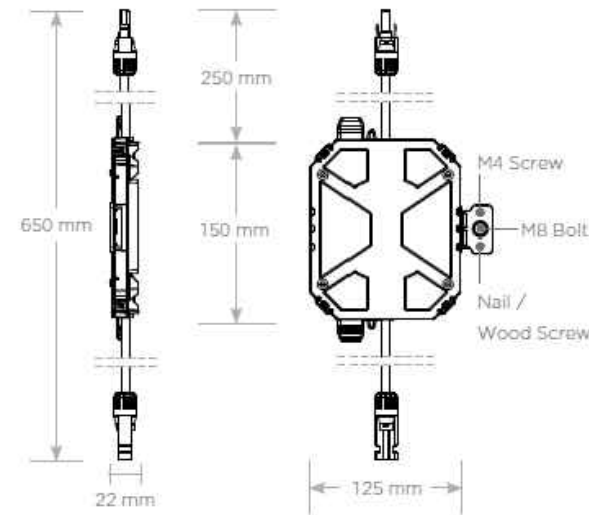

UL 3741 PV HAZARD CONTROL (AND PVRSA) COMPATIBILITY

Tesla Solar Roof and Tesla/Zep Z5 Arrays using the following modules are certified to UL 3741 and UL 1741 PVRSA when installed with the Tesla Solar Inverter and Solar Shutdown Devices. See the Tesla Solar Inverter Installation Manual for detailed instructions and for guidance on installing Tesla Solar Inverter and Solar Shutdown Devices with other modules.

Brand	Model	Required Solar Shutdown Devices
Tesla	Solar Roof V3	1 Solar Shutdown Device per 10 modules
Tesla	Tesla TxxxS (where xxx = 405 to 450 W, increments of 5)	1 Solar Shutdown Device per 3 modules ¹
Tesla	Tesla TxxxH (where xxx = 395 to 415 W, increments of 5)	1 Solar Shutdown Device per 3 modules
Hanwha	Q.PEAK DUO BLK-G5	1 Solar Shutdown Device per 3 modules
Hanwha	Q.PEAK DUO BLK-G6+	1 Solar Shutdown Device per 3 modules

¹Exception: Tesla solar modules installed in locations where the max Voc for three modules at low design temperatures exceeds 165 V shall be limited to two modules between Solar Shutdown Devices.

TESLA

NA 2022-05-06

TESLA.COM/ENERGY



RENU ENERGY SOLUTIONS, LLC

801 PRESSLEY ROAD, SUITE 100
CHARLOTTE, NORTH CAROLINA, 28217
704-525-6767 | RENUENERGYSOLUTIONS.COM

NC GC #76615
NC ELE #U.34519

PREPARED BY:
RENU ENERGY SOLUTIONS
LEVI JOHNSON

SCALE: NTS

SHEET SIZE: 11" x 17"

TEMPLATE V2.0

AHJ: HARNETT COUNTY

APN: 0539-71-5559.000

DATE: 09/09/2024

NICOLE THOMPSON

185 CLYDE DOG COURT
LILLINGTON, NC 27546

PV-8
EQUIPMENT
DATASHEET

DESCRIPTION: SNAPNRACK, UR-40 RAIL	DRAWN BY: mwatkins	 <small>595 MARKET STREET, 29TH FLOOR • SAN FRANCISCO, CA 94105 USA PHONE (415) 580-6500 • FAX (415) 580-6502</small> <small>THE INFORMATION IN THIS DRAWING IS CONFIDENTIAL AND PROPRIETARY. ANY REPRODUCTION, DISCLOSURE, OR USE THEREOF IS PROHIBITED WITHOUT THE WRITTEN CONSENT OF SUNRUN SOUTH LLC.</small>
PART NUMBER(S): 232-02449, 232-02450, 232-02451	REVISION: B	

UR-40 RAIL PROPERTIES	
SKU	FINISH
232-02449	MILL
232-02450	CLEAR
232-02451	BLACK

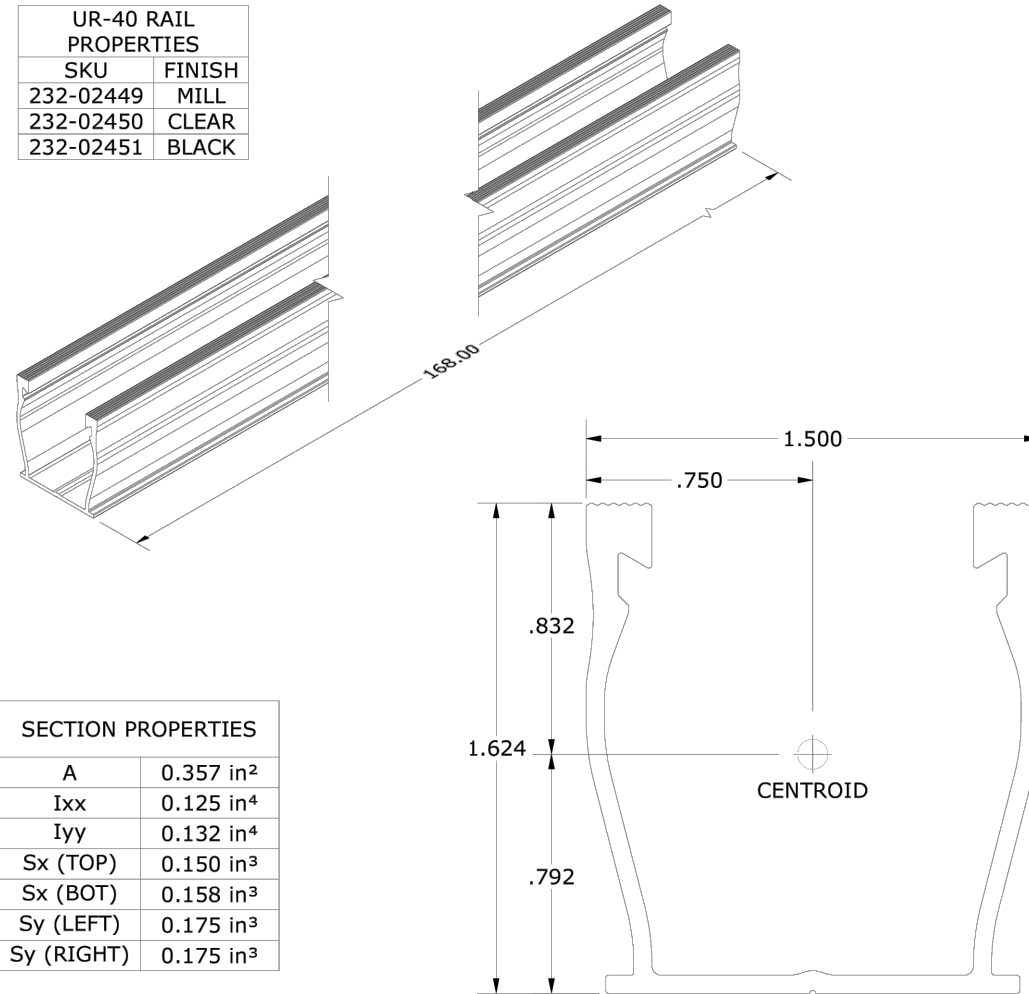

SECTION PROPERTIES	
A	0.357 in ²
Ixx	0.125 in ⁴
Iyy	0.132 in ⁴
Sx (TOP)	0.150 in ³
Sx (BOT)	0.158 in ³
Sy (LEFT)	0.175 in ³
Sy (RIGHT)	0.175 in ³

ALL DIMENSIONS IN INCHES		
MATERIALS:	6000 SERIES ALUMINUM	OPTIONS:
DESIGN LOAD (LBS):	N/A	CLEAR / BLACK ANODIZED
ULTIMATE LOAD (LBS):	N/A	MILL FINISH
TORQUE SPECIFICATION:	N/A LB-FT	BUNDLES OF 144
CERTIFICATION:	UL 2703, FILE E359313	BOXES OF 8
WEIGHT (LBS):	5.85	



RENU ENERGY SOLUTIONS, LLC
801 PRESSLEY ROAD, SUITE 100
CHARLOTTE, NORTH CAROLINA, 28217
704-525-6767 | RENUENERGYSOLUTIONS.COM

NC GC #76615
NC ELE #U.34519

PREPARED BY:
RENU ENERGY SOLUTIONS
LEVI JOHNSON



SCALE: NTS
SHEET SIZE: 11" x 17"
TEMPLATE V2.0

AHJ: HARNETT COUNTY
APN: 0539-71-5559.000
DATE: 09/09/2024

NICOLE THOMPSON
185 CLYDE DOG COURT
LILLINGTON, NC 27546

PV-9
EQUIPMENT
DATASHEET

AnchorFoot™

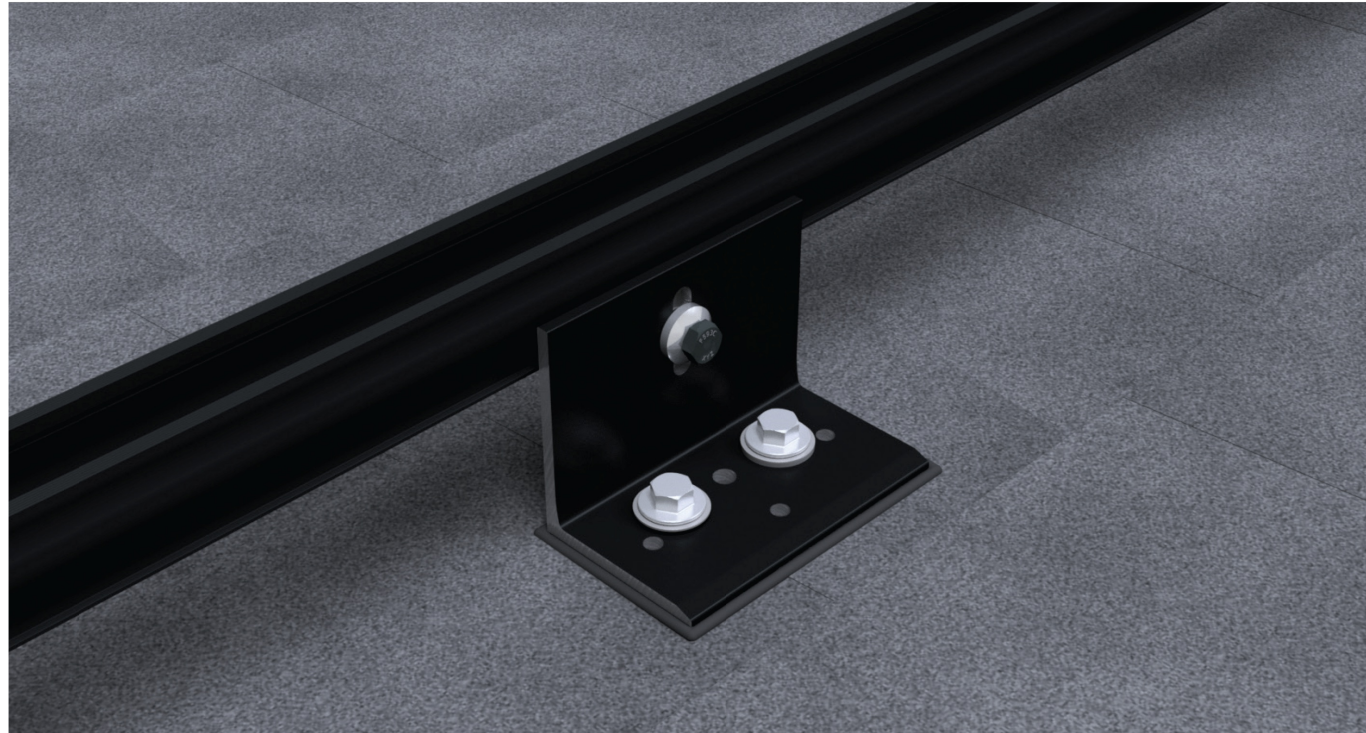

SnapNrack AnchorFoot™ & DeckAnchor™

are the latest innovation designed to reduce the number of roof fasteners when mounting direct to deck and provide maximum flexibility to mount anywhere on the roof. Engineered with butyl, now installers do not have to add sealant to the bottom of the mount, simplifying the installation process and further protecting the roof.

AnchorFoot™

- Pre-installed butyl for easy peel & stick installation allows for no disruption to composition shingles
- Industry-leading .200" thick butyl allows installation over shingles without cutting pieces
- Flexible direct to deck mounting options with (2) DeckAnchors or (4) #14 wood screws
- Flexible rafter mounting options with (1) 5/16" lag or (2) #14 wood screws
- Ships pre-assembled with Ultra Rail Mounting Clamp for easy rail attachment
- Rated for UL2703 Bonding & Grounding with TAS 100A Wind Driven Rain Testing for waterproof certification



Deck Mounting, *re-imagined.*



Flexible direct to deck mounting & rafter mounting options



Pre-installed butyl for easy worry-free sealing



Compatible with proprietary DeckAnchor™ fasteners cutting the number of deck fasteners in half, from 4 to 2



Single Tool installation & snap-in features as with all SnapNrack products



DeckAnchor

- Proprietary fastening technology to reduce the number of screws for direct to deck mounting
- Familiar 1/2" hex head to maintain the SnapNrack tradition of a single tool install
- Wide threads securely grip the wood deck and significantly reduces the potential for over-tightening
- TAS 100A Wind Driven Rain Testing + ASTM D1761 Screw Capacities

Quality. Performance. Innovation.

SnapNrack solutions are focused on simplifying the installation experience through intuitive products and the best wire management in the industry.

SnapNrack®

877-732-2860

www.snapnrack.com

contact@snapnrack.com

© 2023 by SnapNrack® Solar Mounting Solutions. All rights reserved.

Start Installing AnchorFoot™ Today!



RENU ENERGY SOLUTIONS, LLC

801 PRESSLEY ROAD, SUITE 100
CHARLOTTE, NORTH CAROLINA, 28217
704-525-6767 | RENUENERGYSOLUTIONS.COM

NC GC #76615
NC ELE #U.34519

PREPARED BY:
RENU ENERGY SOLUTIONS
LEVI JOHNSON

SCALE: NTS

SHEET SIZE: 11" x 17"

TEMPLATE V2.0

AHJ: HARNETT COUNTY

APN: 0539-71-5559.000

DATE: 09/09/2024

NICOLE THOMPSON

185 CLYDE DOG COURT
LILLINGTON, NC 27546

PV-10

EQUIPMENT
DATASHEET

POWERWALL Backup Gateway 2

The Backup Gateway 2 for Tesla Powerwall provides energy management and monitoring for solar self-consumption, time-based control, and backup.

The Backup Gateway 2 controls connection to the grid, automatically detecting outages and providing a seamless transition to backup power. When equipped with a main circuit breaker, the Backup Gateway 2 can be installed at the service entrance. When the optional internal panelboard is installed, the Backup Gateway 2 can also function as a load center.

The Backup Gateway 2 communicates directly with Powerwall, allowing you to monitor energy use and manage backup energy reserves from any mobile device with the Tesla app.



PERFORMANCE SPECIFICATIONS

AC Voltage (Nominal)	120/240V
Feed-In Type	Split Phase
Grid Frequency	60 Hz
Current Rating	200 A
Maximum Input Short Circuit Current	10 kA ¹
Overcurrent Protection Device	100-200A; Service Entrance Rated ¹
Overvoltage Category	Category IV
AC Meter	Revenue accurate (+/- 0.2%)
Primary Connectivity	Ethernet, Wi-Fi
Secondary Connectivity	Cellular (3G, LTE/4G) ²
User Interface	Tesla App
Operating Modes	Support for solar self-consumption, time-based control, and backup
Backup Transition	Automatic disconnect for seamless backup
Modularity	Supports up to 10 AC-coupled Powerwalls
Optional Internal Panelboard	200A 6-space / 12 circuit Eaton BR Circuit Breakers
Warranty	10 years

¹When protected by Class J fuses, Backup Gateway 2 is suitable for use in circuits capable of delivering not more than 22kA symmetrical amperes.
²The customer is expected to provide internet connectivity for Backup Gateway 2; cellular should not be used as the primary mode of connectivity. Cellular connectivity subject to network operator service coverage and signal strength.

MECHANICAL SPECIFICATIONS

Dimensions	660 mm x 411 mm x 149 mm (26 in x 16 in x 6 in)
Weight	20.4 kg (45 lb)
Mounting options	Wall mount, Semi-flush mount

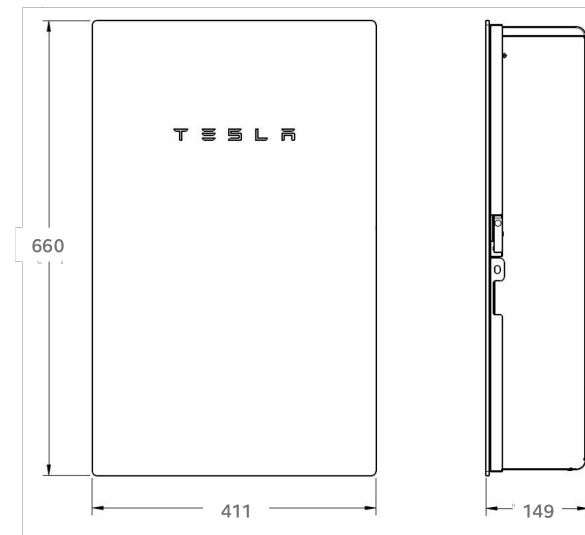

COMPLIANCE INFORMATION

Certifications	UL 67, UL 869A, UL 916, UL 1741 PCS CSA 22.2 0.19, CSA 22.2 205
Emissions	FCC Part 15, ICES 003

ENVIRONMENTAL SPECIFICATIONS

Operating Temperature	-20°C to 50°C (-4°F to 122°F)
Operating Humidity (RH)	Up to 100%, condensing
Maximum Elevation	3000 m (9843 ft)
Environment	Indoor and outdoor rated
Enclosure Type	NEMA 3R

T E S L A

NA 2020-05-23

TESLA.COM/ENERGY



RENU ENERGY SOLUTIONS, LLC

801 PRESSLEY ROAD, SUITE 100
CHARLOTTE, NORTH CAROLINA, 28217
704-525-6767 | RENUENERGYSOLUTIONS.COM

NC GC #76615
NC ELE #U.34519

PREPARED BY:
RENU ENERGY SOLUTIONS
LEVI JOHNSON

SCALE: NTS

SHEET SIZE: 11" x 17"

TEMPLATE V2.0

AHJ: HARNETT COUNTY

APN: 0539-71-5559.000

DATE: 09/09/2024

NICOLE THOMPSON

185 CLYDE DOG COURT
LILLINGTON, NC 27546

PV-11
EQUIPMENT
DATASHEET

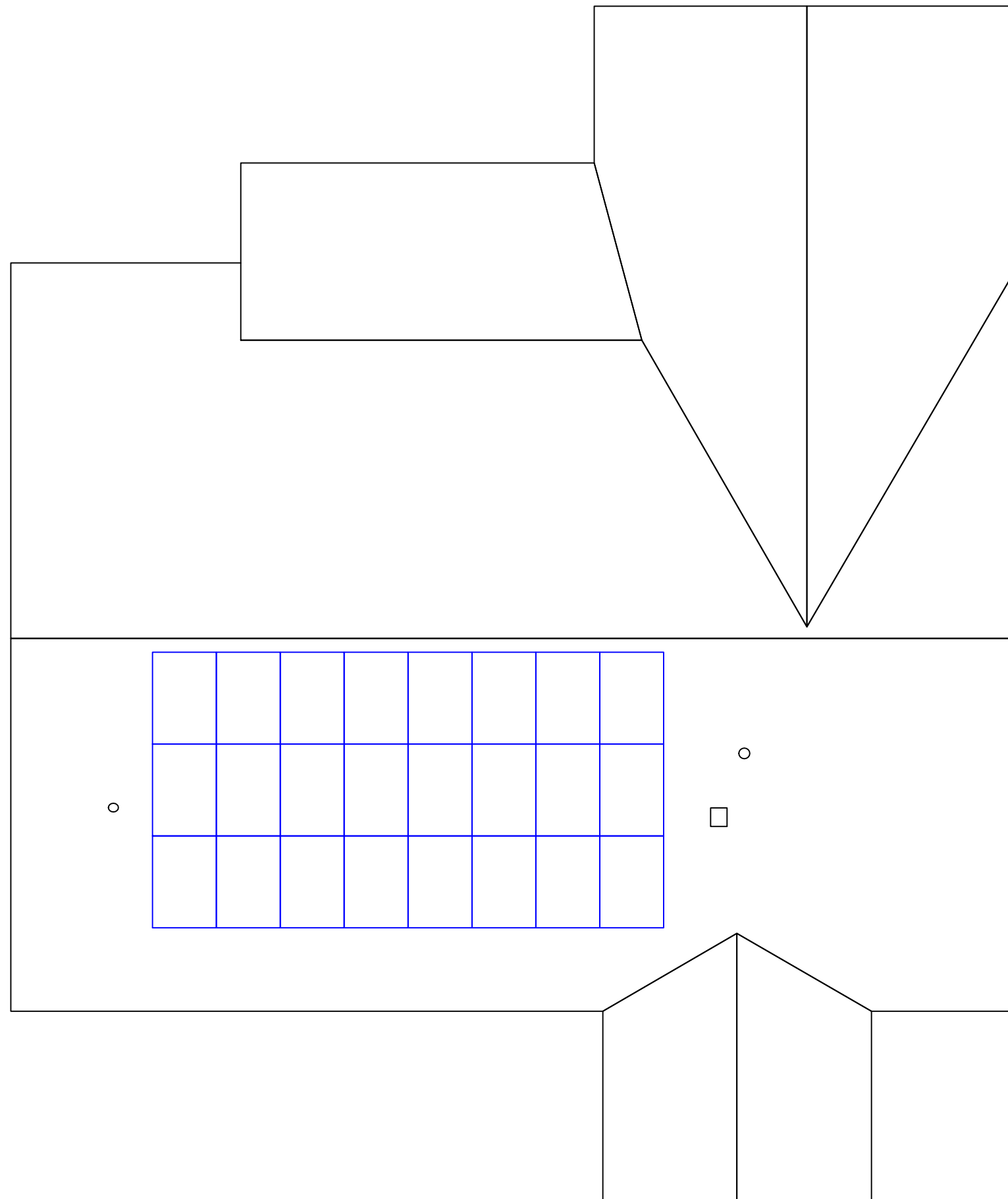

RENU ENERGY SOLUTIONS, LLC

801 PRESSLEY ROAD, SUITE 100
 CHARLOTTE, NORTH CAROLINA, 28217
 704-525-6767 | RENUENERGYSOLUTIONS.COM

NC GC #76615
 NC ELE #U.34519

PREPARED BY:
 RENU ENERGY SOLUTIONS
 LEVI JOHNSON

SCALE: NTS

SHEET SIZE: 11" x 17"

TEMPLATE V2.0

AHJ: HARNETT COUNTY

APN: 0539-71-5559.000

DATE: 09/09/2024

NICOLE THOMPSON

185 CLYDE DOG COURT
 LILLINGTON, NC 27546

PV-12
 MAPPING
 SHEET