

SCOPE OF WORK

TO INSTALL A SOLAR PHOTOVOLTAIC (PV) SYSTEM AT THE RODRIGUEZ RESIDENCE, LOCATED AT 105 MICAHS WAY NORTH, SPRING LAKE, NORTH CAROLINA. THE POWER GENERATED BY THE PV SYSTEM WILL BE INTERCONNECTED WITH THE UTILITY GRID THROUGH THE EXISTING ELECTRICAL SERVICE EQUIPMENT. THE PV SYSTEM DOES NOT INCLUDE STORAGE BATTERIES.

SYSTEM RATING

8.075 kW DC STC
7.296 kW AC

EQUIPMENT SUMMARY

(19) SUNPOWER SPR-M425-H-AC PV MODULES
(19) TYPE H MODULE-INTEGRATED MICRO-INVERTERS: ENPHASE IQ7HS [240V] PV INVERTERS

SHEET INDEX

PV-0 COVER
PV-1 SITE MAP AND PV LAYOUT
PV1A RACKING PLAN
PV-2 STRING MAP & MONITORING LAYOUT
PV-3 ELECTRICAL DIAGRAM
PV-4 EQ WALL
PV-5 MOUNTING DETAIL
PV-6 SYSTEM LABELING DETAIL
PV-7 SITE DIRECTORY PLACARD
PV-8 SAFETY PLAN

GOVERNING CODES

2017 NATIONAL ELECTRICAL CODE
2018 NORTH CAROLINA RESIDENTIAL CODE
2018 NORTH CAROLINA STATE BUILDING CODE
UNDERWRITERS LABORATORIES (UL) STANDARDS
OSHA 29 CFR 1910.269

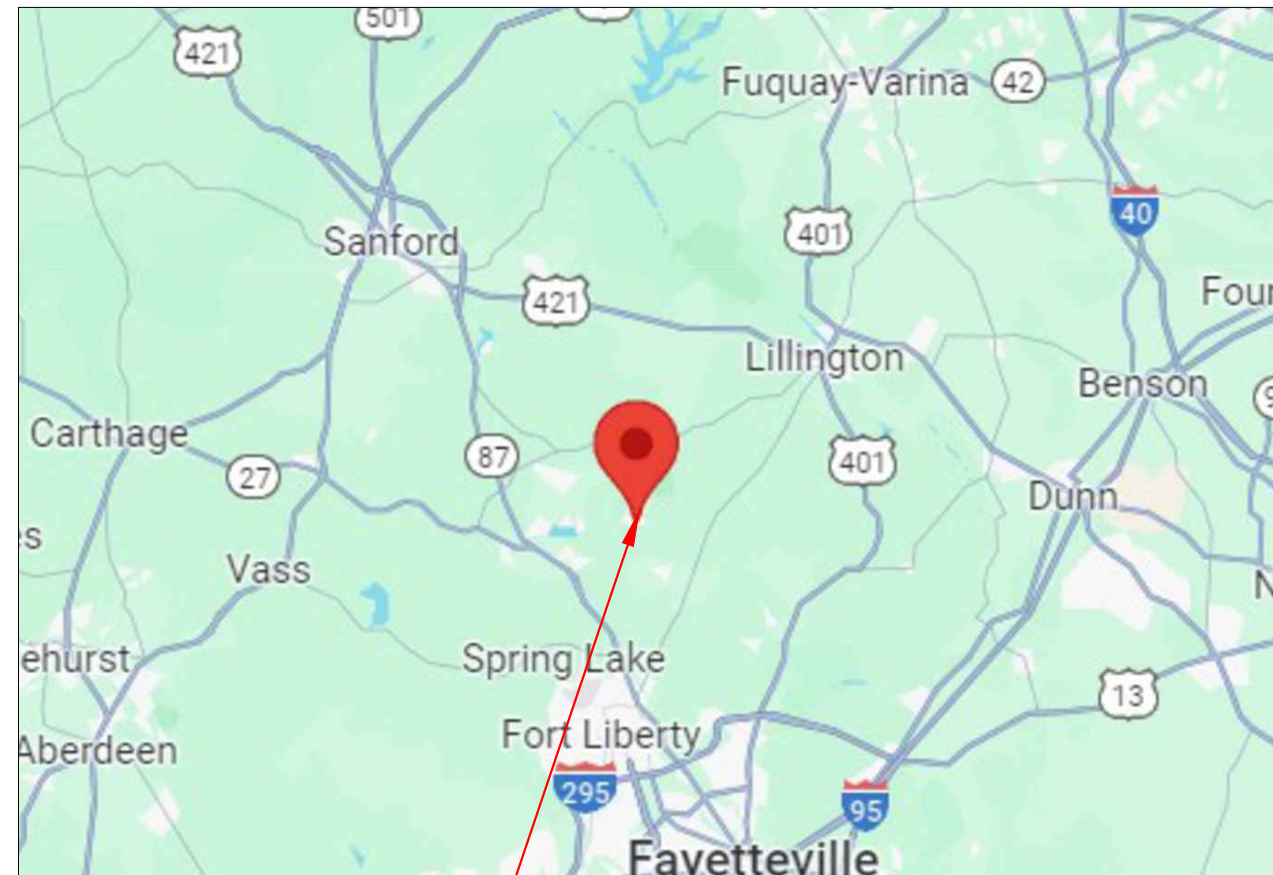

PROJECT LOCATION

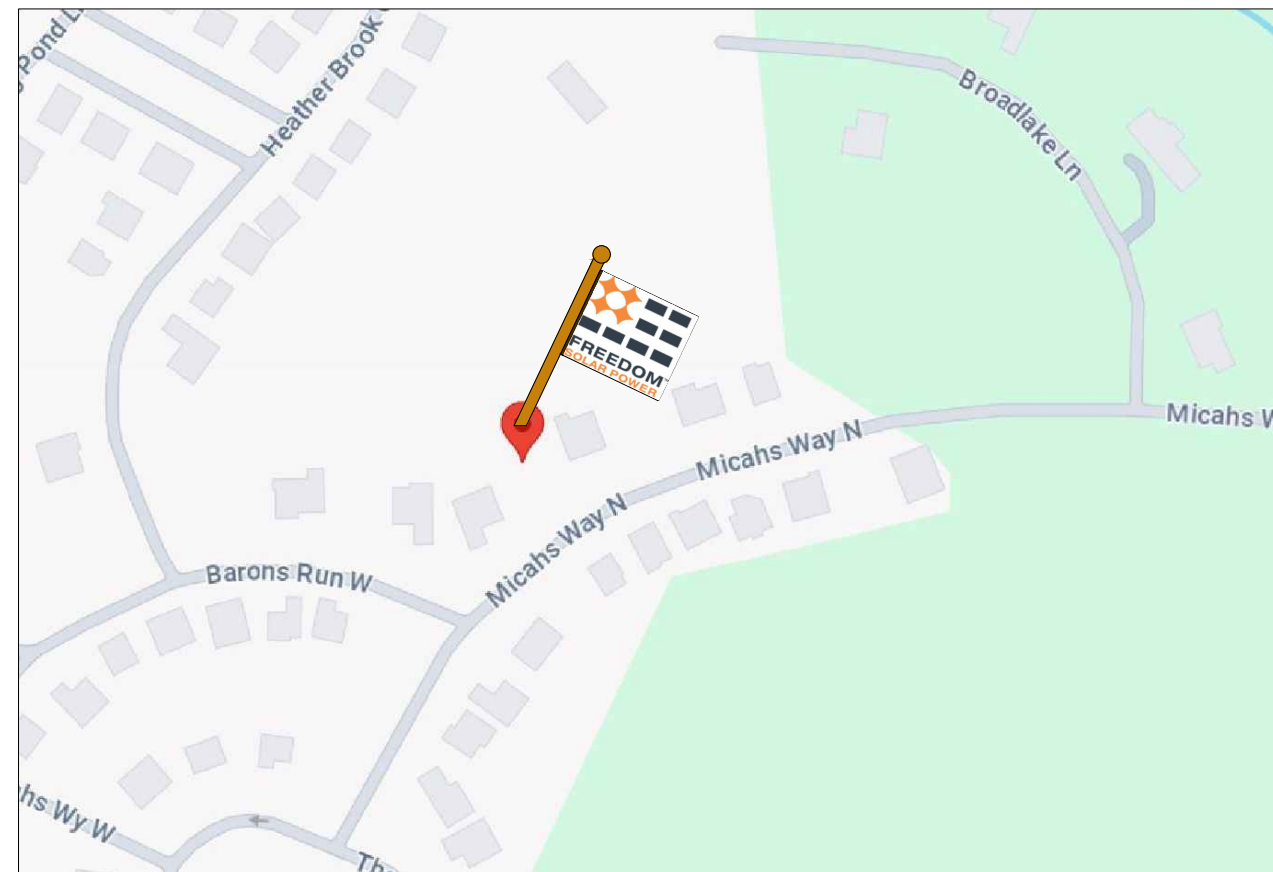

VICINITY MAP

CONTRACTOR



**FREEDOMTM
SOLAR POWER**

FREEDOM SOLAR LLC
4801 FREDRICH LN, STE 100
AUSTIN, TX 78744
512-759-8313
TECL # 28621

REVISIONS		
DESCRIPTION	DATE	REV
DESIGN PACKET	08/16/2024	-

PE STAMP

PROJECT NAME

SIGFREDO MATOS RODRIGUEZ
105 MICAHS WAY NORTH
SPRING LAKE, NORTH
CAROLINA, 28390

(706) 691-1266
PROJECT ID: 115404

SHEET NAME

COVER

SHEET SIZE

ANSI B
11" x 17"

SHEET NUMBER

PV-0

LEAD ID: 115404

CONSTRUCTION SUMMARY

- (19) (SUNPOWER SPR-M425-H-AC) SOLAR MODULES, 8.075 kW DC STC
MODULE DIMENSIONS = 40.6" X 73.7" X 1.57"
- (19) TYPE H MODULE-INTEGRATED MICRO-INVERTERS: ENPHASE IQ7HS [240V] PV INVERTERS
COMBINED INVERTER OUTPUT = 7.296 kW AC.
- (01) SUNPOWER MONITORING

RACKING: SUNPOWER CLASSIC INVISIMOUNT

ATTACHMENT: PEGASUS INSTAFLASH

SITE DETAILS

ROOF TYPE: ASPHALT SHINGLE

ARRAY #1 - TILT = 38°, AZIMUTH = 342°

ARRAY #2 - TILT = 37°, AZIMUTH = 162°

NOTE : PE STAMPS REQUIRED IF:

- WEIGHT OF ARRAY IS >3PSF
 - MORE THAN 1-LAYER OF SHINGLE
 - ROOF TYPE IS OTHER THAN COMP SHINGLES
 - WIND SPEED IS GREATER THAN 140 MPH
- IF DESIGN PACK IS NOT STAMPED, MUST INCLUDE EXCEPTION STATEMENT IN RED:

-PANEL WEIGHT EQUALS 2.5 LBS PER SQ FT,
LESS THAN 3 LBS PER SQ FT

**NO CUTTING AND COVERING PLUMBING VENTS AT ALL,
PVC PIPES CAN BE RELOCATED WITH ROOF JACK**

FALL PROTECTION REQUIRED

CONSTRUCTION NOTES

- 1.) ALL EQUIPMENT SHALL BE INSTALLED IN ACCORDANCE WITH THE MANUFACTURER'S INSTALLATION INSTRUCTIONS.
- 2.) ALL OUTDOOR EQUIPMENT SHALL BE RAINTIGHT WITH MINIMUM NEMA 3R RATING.
- 3.) ALL LOCATIONS ARE APPROXIMATE AND REQUIRE FIELD VERIFICATION.

PV ARRAY #1
(9) MODULES

SOUTH RIVER EMC REVENUE
METER
#69021042
GROUNDING ELECTRODE
ENCLOSED CIRCUIT BREAKER
MAIN DISTRIBUTION PANEL#2
SOLAR LOAD CENTER
MONITORING
PV AC DISCONNECT
-VISIBLE
-LOCKABLE
-LABELED
(OUTSIDE HOUSE WALL)

MAIN DISTRIBUTION PANEL#1
(INSIDE GARAGE WALL)

PV ARRAY #2
(10) MODULES



CONTRACTOR

**FREEDOMTM
SOLAR POWER**

FREEDOM SOLAR LLC
4801 FREDRICH LN, STE 100
AUSTIN, TX 78744
512-759-8313
TECL # 28621

REVISIONS

DESCRIPTION	DATE	REV
DESIGN PACKET	08/16/2024	-

PE STAMP

PROJECT NAME

SIGFREDO MATOS RODRIGUEZ
105 MICAH'S WAY NORTH
SPRING LAKE, NORTH
CAROLINA, 28390

(706) 691-1266
PROJECT ID: 115404

SHEET NAME

**SITE MAP &
PV LAYOUT**

SHEET SIZE

**ANSI B
11" x 17"**

SHEET NUMBER

PV-1

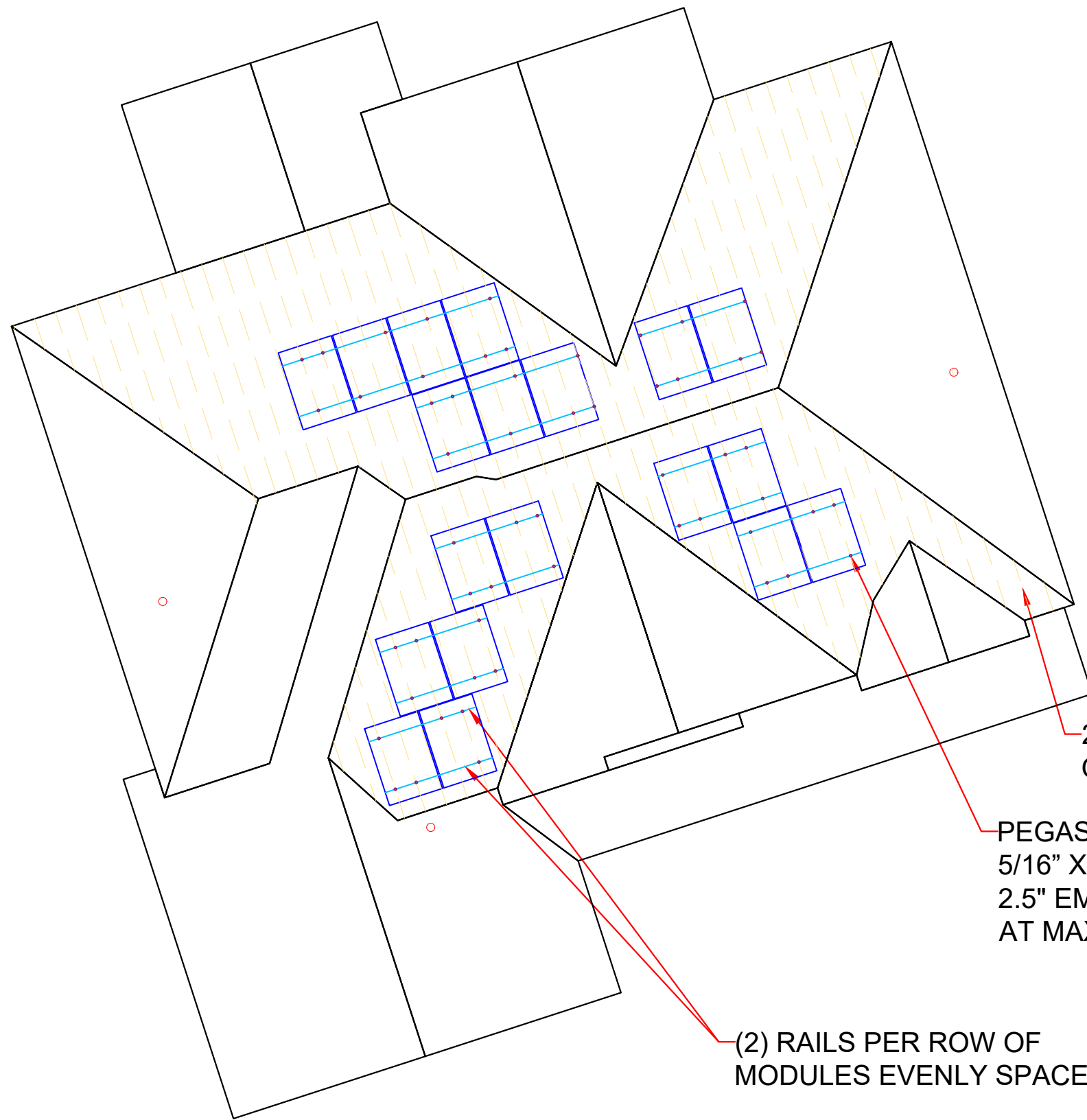

CONTRACTOR



**FREEDOMTM
SOLAR POWER**

FREEDOM SOLAR LLC
4801 FREDRICH LN, STE 100
AUSTIN, TX 78744
512-759-8313
TECL # 28621

REVISIONS		
DESCRIPTION	DATE	REV
DESIGN PACKET	08/16/2024	-

PE STAMP

PROJECT NAME

SIGFREDO MATOS RODRIGUEZ
105 MICAH'S WAY NORTH
SPRING LAKE, NORTH
CAROLINA, 28390

(706) 691-1266
PROJECT ID: 115404

2"X10" RAFTERS AT 16"
O.C. TYP.

PEGASUS INSTAFLASH BLACK,
5/16" X 4.0" SS LAG WITH MIN.
2.5" EMBEDMENT INTO THE FRAMING
AT MAX 48" O.C. ALONG RAILS

(2) RAILS PER ROW OF
MODULES EVENLY SPACED

CONSTRUCTION NOTES

- 1.) ALL EQUIPMENT SHALL BE INSTALLED IN ACCORDANCE WITH THE MANUFACTURER'S INSTALLATION INSTRUCTIONS.
- 2.) ALL OUTDOOR EQUIPMENT SHALL BE RAIN-TIGHT WITH MINIMUM NEMA 3R RATING.
- 3.) ALL LOCATIONS ARE APPROXIMATE AND REQUIRE FIELD VERIFICATION.

SHEET NAME

RACKING PLAN

SHEET SIZE

**ANSI B
11" x 17"**

SHEET NUMBER

PV-1A

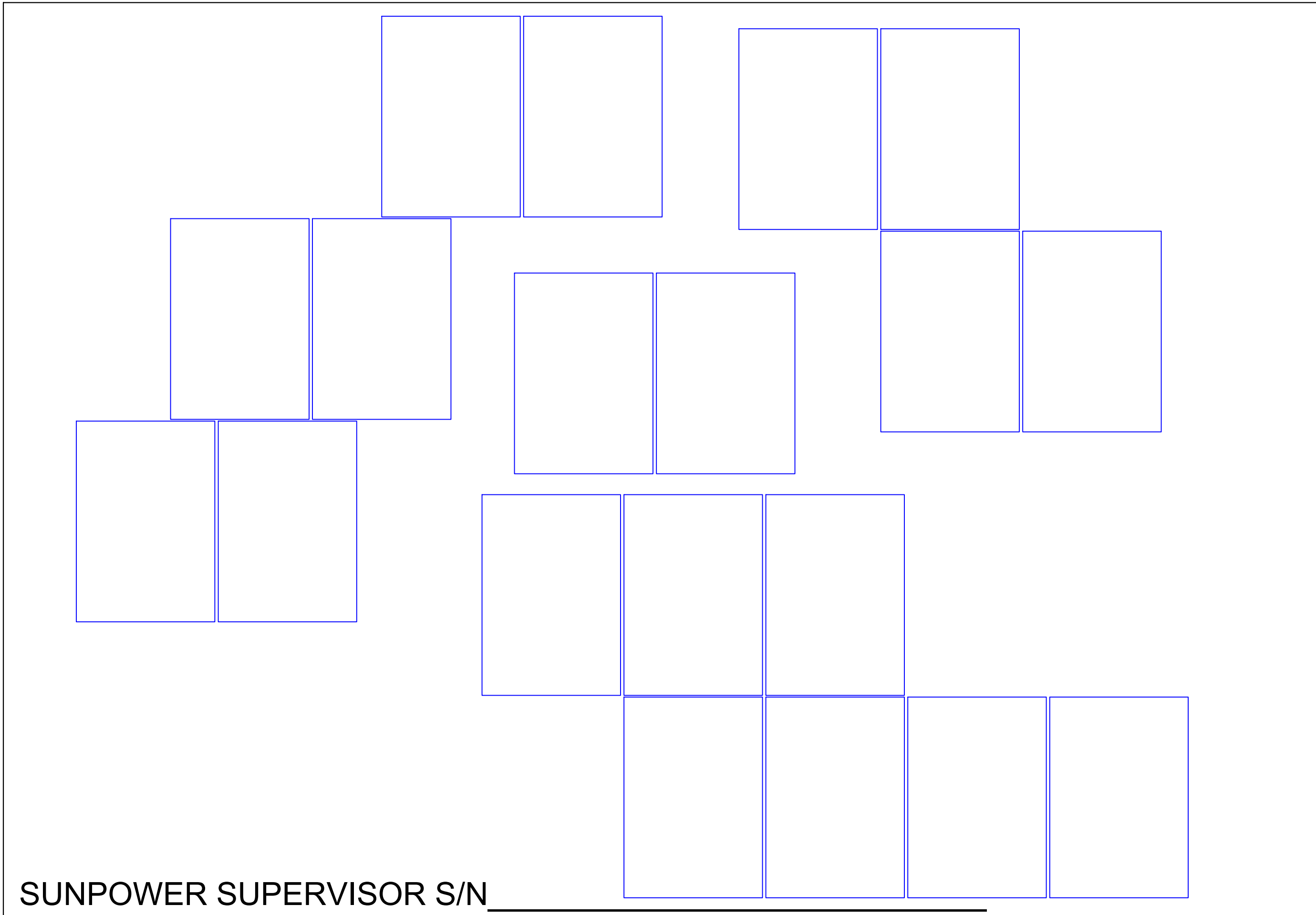

SUNPOWER SUPERVISOR S/N _____

CONTRACTOR



**FREEDOM™
SOLAR POWER**

FREEDOM SOLAR LLC
4801 FREDRICH LN, STE 100
AUSTIN, TX 78744
512-759-8313
TECL # 28621

REVISIONS

DESCRIPTION	DATE	REV
DESIGN PACKET	08/16/2024	-

PE STAMP

PROJECT NAME

SIGFREDO MATOS RODRIGUEZ
105 MICAHS WAY NORTH
SPRING LAKE, NORTH
CAROLINA, 28390
(706) 691-1266
PROJECT ID: 115404

SHEET NAME

STRING MAP &
MONITORING
LAYOUT

SHEET SIZE

ANSI B
11" x 17"

SHEET NUMBER

PV-2

SOLAR ARRAY - 8.075 KW DC STC, 7.296 KW AC, 1-PHASE
 (19) SUNPOWER SPR-M425-H-AC PV MODULES

(19) TYPE H MODULE-INTEGRATED MICRO-INVERTERS: ENPHASE IQ7HS [240V] PV INVERTERS

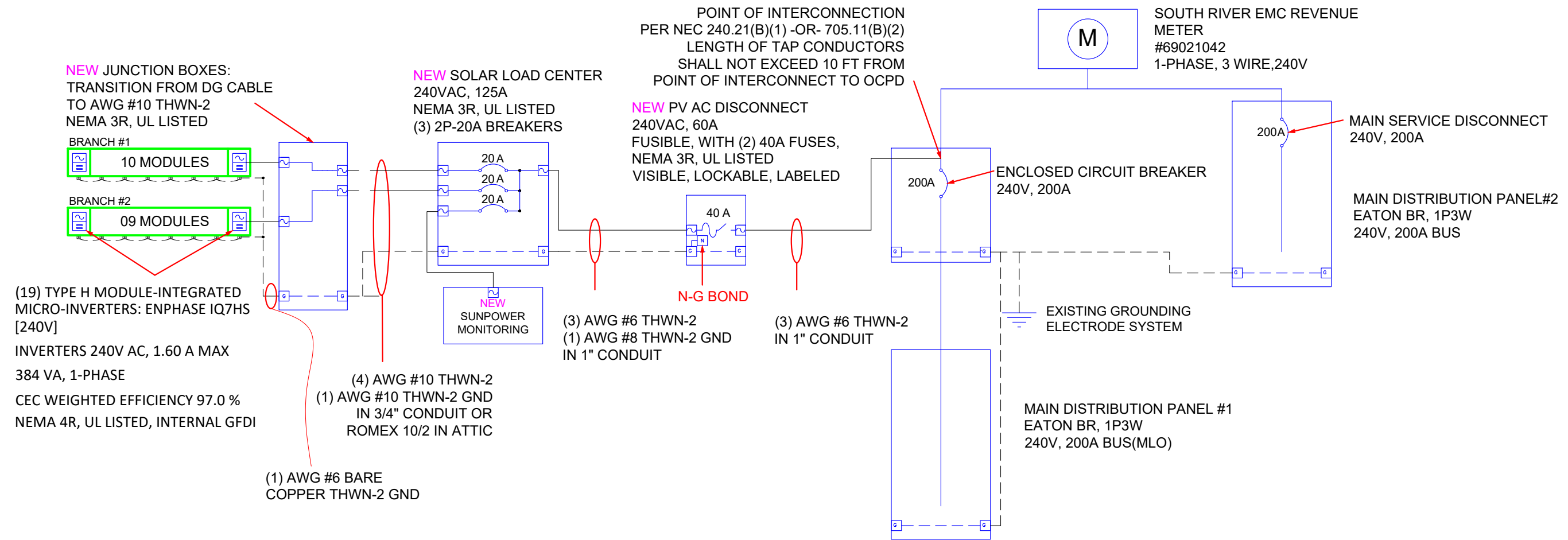

ELECTRICAL NOTES

- 1.) ALL EQUIPMENT TO BE LISTED BY UL OR OTHER NRTL, AND LABELED FOR ITS APPLICATION.
- 2.) ALL CONDUCTORS SHALL BE COPPER. ALUMINUM CONDUCTORS MAY BE USED IF CORRECTLY UPSIZED FOR AMPACITY RATING PER NEC 310.12 OR 310.16. ALL CONDUCTORS SHALL BE RATED FOR 600V AND 90°C WET ENVIRONMENT UNLESS OTHERWISE NOTED.
- 3.) WORKING CLEARANCES AROUND ALL NEW AND EXISTING ELECTRICAL EQUIPMENT SHALL COMPLY WITH NEC 110.26.
- 4.) DRAWINGS INDICATE THE GENERAL ARRANGEMENT OF SYSTEMS. CONTRACTOR SHALL FURNISH ALL NECESSARY OUTLETS, SUPPORTS, FITTINGS AND ACCESSORIES TO FULFILL APPLICABLE CODES AND STANDARDS.
- 5.) WHERE SIZES OF JUNCTION BOXES, RACEWAYS, AND CONDUITS ARE NOT SPECIFIED, THE CONTRACTOR SHALL SIZE THEM ACCORDINGLY. SPECIFIED CONDUIT AND WIRE SIZES ARE MINIMUM REQUIREMENTS AND LARGER SIZES SHALL BE PERMITTED.
- 6.) ALL WIRE TERMINATIONS SHALL BE APPROPRIATELY LABELED AND READILY VISIBLE.
- 7.) MAXIMUM MOUNTING HEIGHT FROM GRADE TO CENTER OF METER SOCKET SHALL BE 72" FOR RESIDENTIAL SINGLE PHASE METER SOCKETS 0-320 AMPS. MINIMUM MOUNTING HEIGHT IS 30" FROM FOR AUSTIN ENERGY, AND 48" FOR ALL OTHER JURISDICTIONS
- 8.) MINIMUM HORIZONTAL CLEARANCE FROM GAS REGULATOR TO ANY ELECTRICAL ENCLOSURE IS 36", EXCEPT AUSTIN ENERGY WHICH REQUIRES 48" CLEARANCE FROM GAS TO METER SOCKET
- 9.) PV DISCONNECT SHALL BE VISIBLE, LOCKABLE AND LABELED AND THE DOOR CANNOT BE OPENED WHEN HANDLE IS IN ON POSITION
- 10.) BY DEFAULT THE MONITORING DEVICE IS SHOWN CONNECTED TO A 20-AMP BREAKER IN THE SOLAR LOAD CENTER. ALTERNATIVELY, THE MONITORING DEVICE MAY BE CONNECTED TO A 20-AMP BREAKER AT THE MAIN DISTRIBUTION PANEL.
- 11.) ALL EQUIPMENT TERMINATIONS SHALL BE RATED FOR 75 DEGREES OR GREATER
- 12.) ALL CT WIRES SHALL BE CONSIDERED CLASS 1 PER NEC ARTICLE 725, AND BE MARKED AS RATED FOR 600V. PER 725.48(A) CLASS 1 CIRCUITS SHALL BE PERMITTED TO OCCUPY THE SAME RACEWAY AS OTHER CIRCUITS PROVIDED ALL CONDUCTORS ARE INSULATED FOR THE MAXIMUM VOLTAGE OF ANY CONDUCTOR IN THE RACEWAY.
- 13.) AWG #10 COPPER CONDUCTORS ARE SPECIFIED AS THE DEFAULT WIRE REQUIRED FROM THE PV ARRAY TO THE SOLAR LOAD CENTER, HOWEVER, AWG #12 COPPER CONDUCTORS MAY BE UTILIZED IF BOTH OF THE FOLLOWING CONDITIONS ARE MET: THE LENGTH OF THE CONDUCTOR IS LESS THAN 75 FT AND THERE ARE LESS THAN 8 CURRENT-CARRYING CONDUCTORS WITHIN THE RACEWAY.

CALCULATIONS FOR CURRENT CARRYING CONDUCTORS	CALCULATIONS FOR OVERCURRENT DEVICES
<p>INVERTER OUTPUT WIRE AMPACITY CALCULATION [NEC 690.8(A)(3)]: 1.60A PER INVERTER TYPE H MODULE-INTEGRATED MICRO-INVERTERS: ENPHASE IQ7HS [240V] MAXIMUM INVERTER BRANCH CURRENT = (10)(1.60A) = 16.00A CONTINUOUS USE: #10 WIRE 75°C DERATED AMPACITY = (0.80)(35.0A) = 28.00A 28.00A > 16.00A CONDITIONS OF USE: #10 WIRE 90°C DERATED AMPACITY = (0.91)(0.80)(40.0A) = 29.12A 29.12A > 16.00A</p> <p>SOLAR LOAD CENTER OUTPUT WIRE AMPACITY CALCULATION [NEC 690.8(A)(3)]: 1.60A PER INVERTER TYPE H MODULE-INTEGRATED MICRO-INVERTERS: ENPHASE IQ7HS [240V] COMBINED CURRENT = (19)(1.60A) = 30.40A CONTINUOUS USE: #6 WIRE 75°C DERATED AMPACITY = (0.80)(65A) = 52.00A 52.00A > 30.40A CONDITIONS OF USE: #6 WIRE 90°C DERATED AMPACITY = (0.91)(75A) = 68.25A 68.25A > 30.40A</p>	<p>INVERTER BRANCH AC CURRENT CALCULATION [NEC 690.8(A)(3)]: 1.60A PER INVERTER TYPE H MODULE-INTEGRATED MICRO-INVERTERS: ENPHASE IQ7HS [240V] MAXIMUM BRANCH INVERTER CURRENT = (10)(1.60A) = 16.00A MINIMUM OCPD = (16.00A)(1.25) = 20.00A USE 2P-20A BREAKERS IN SOLAR LOAD CENTER FOR INVERTER BRANCH OCPD</p> <p>SYSTEM AC CURRENT CALCULATION [NEC 690.8(A)(3)]: 1.60A PER INVERTER TYPE H MODULE-INTEGRATED MICRO-INVERTERS: ENPHASE IQ7HS [240V] COMBINED CURRENT = (19)(1.60A) = 30.40A MINIMUM OCPD = (30.40A)(1.25) = 38.00A</p> <p>USE (2)40 FUSES IN PV AC DISCONNECT FOR SYSTEM OCPD AWG #6 CONDUCTORS ARE ADEQUATELY PROTECTED BY 40A FUSES</p>

CONTRACTOR

FREEDOM SOLAR POWER
 FREEDOM SOLAR LLC
 4801 FREIDRICH LN, STE 100
 AUSTIN, TX 78744
 512-759-8313
 TECL # 28621

REVISIONS		
DESCRIPTION	DATE	REV
DESIGN PACKET	08/16/2024	-

PE STAMP

PROJECT NAME
SIGFREDO MATOS RODRIGUEZ
 105 MICAHS WAY NORTH
 SPRING LAKE, NORTH
 CAROLINA, 28390
 (706) 691-1266
 PROJECT ID: 115404

SHEET NAME
ELECTRICAL DIAGRAM

SHEET SIZE
**ANSI B
 11" x 17"**

SHEET NUMBER
PV-3

CONTRACTOR



**FREEDOMTM
SOLAR POWER**

FREEDOM SOLAR LLC
4801 FREIDRICH LN, STE 100
AUSTIN, TX 78744
512-759-8313
TECL # 28621

REVISIONS

DESCRIPTION	DATE	REV
DESIGN PACKET	08/16/2024	-

PE STAMP

PROJECT NAME

SIGFREDO MATOS RODRIGUEZ
105 MICAHS WAY NORTH
SPRING LAKE, NORTH
CAROLINA, 28390
(706) 691-1266
PROJECT ID: 115404

SHEET NAME

EQ.WALL

SHEET SIZE

**ANSI B
11" x 17"**

SHEET NUMBER

PV-4

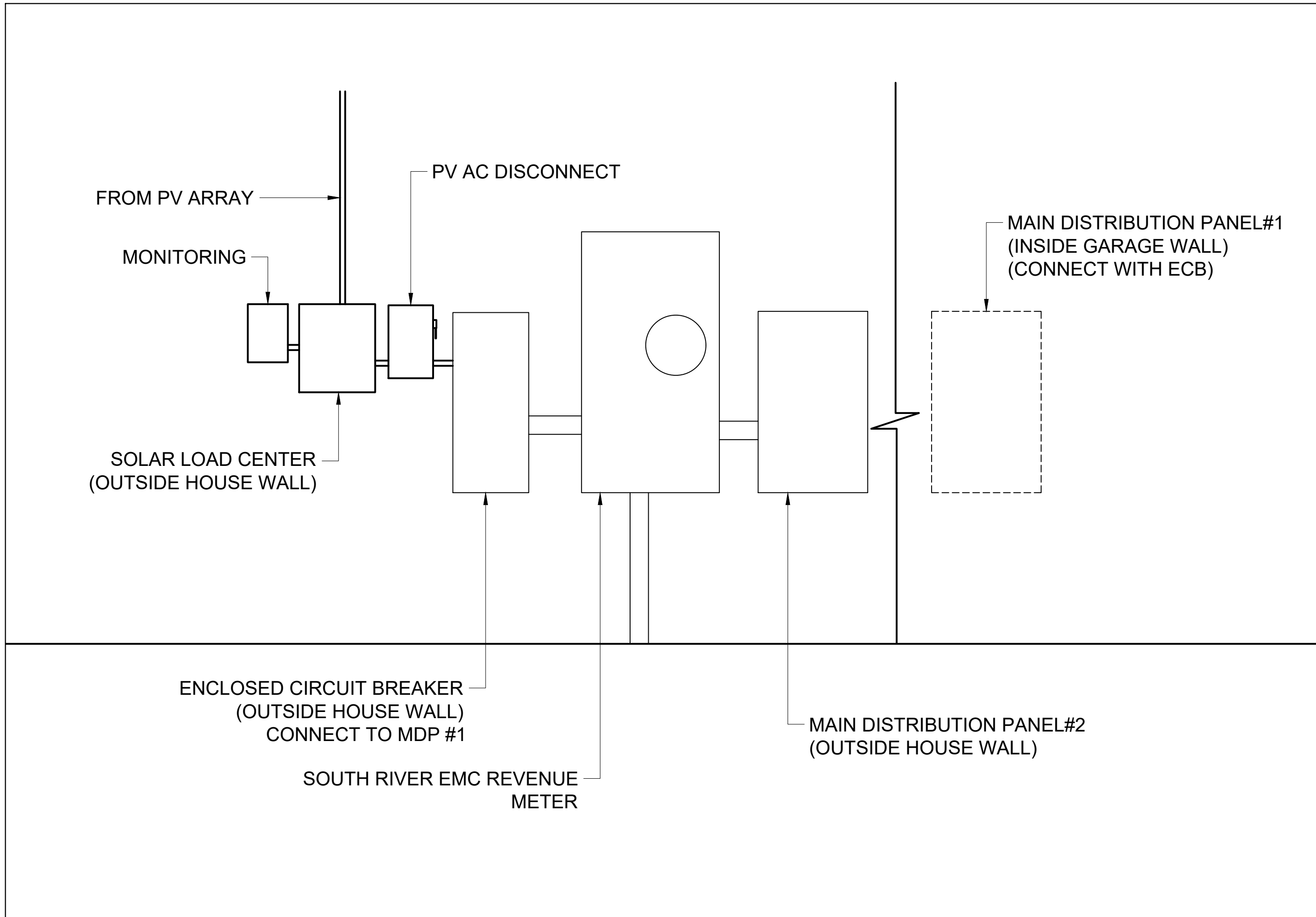

CONTRACTOR



**FREEDOM[™]
SOLAR POWER**

FREEDOM SOLAR LLC
4801 FREIDRICH LN, STE 100
AUSTIN, TX 78744
512-759-8313
TECL # 28621

REVISIONS		
DESCRIPTION	DATE	REV
DESIGN PACKET	08/16/2024	-

PE STAMP

PROJECT NAME

SIGFREDO MATOS RODRIGUEZ
105 MICAH'S WAY NORTH
SPRING LAKE, NORTH
CAROLINA, 28390
(706) 691-1266
PROJECT ID: 115404

SHEET NAME

MOUNTING DETAIL

SHEET SIZE

**ANSI B
11" x 17"**

SHEET NUMBER

PV-5

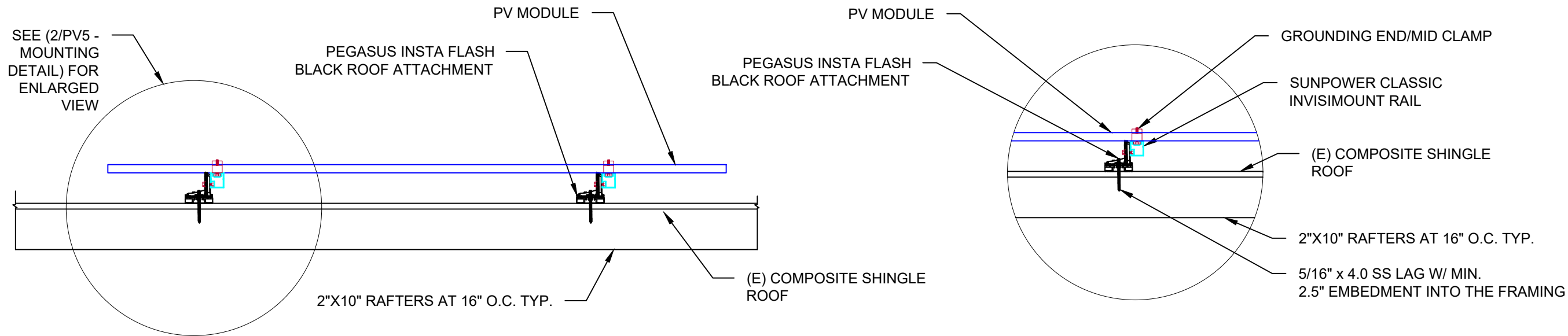

MOUNTING METHOD 1

MOUNTING DETAIL 2
NTS

NOTE: NOT ALL LABELS MAY BE APPLICABLE

SIGNAGE REQUIREMENTS

- > RED BACKGROUND
- > WHITE LETTERING
- > MIN. 3/8" LETTER HEIGHT
- > ALL CAPITAL LETTERS
- > ARIAL OR SIMILAR FONT
- > REFLECTIVE, WEATHER RESISTANT MATERIAL, UL 969

CONTRACTOR



FREEDOM SOLAR POWER
 FREEDOM SOLAR LLC
 4801 FREDRICH LN, STE 100
 AUSTIN, TX 78744
 512-759-8313
 TECL # 28621

REVISIONS		
DESCRIPTION	DATE	REV
DESIGN PACKET	08/16/2024	-

PE STAMP

PROJECT NAME
SIGFREDO MATOS RODRIGUEZ
 105 MICHAHS WAY NORTH
 SPRING LAKE, NORTH
 CAROLINA, 28390
 (706) 691-1266
 PROJECT ID: 115404

SHEET NAME
SYSTEM LABELING DETAIL

SHEET SIZE
**ANSI B
 11" x 17"**

SHEET NUMBER
PV-6

PV SYSTEM DISCONNECT

REQ'D BY: NEC 690.13(B) **A**
 APPLY TO:
 PV DISCONNECT

**WARNING
 ELECTRIC SHOCK HAZARD.
 DO NOT TOUCH TERMINALS.
 TERMINALS ON THE LINE AND
 LOAD SIDES MAY BE
 ENERGIZED IN THE OPEN
 POSITION.**

REQ'D BY: NEC 690.13(B) **B**
 APPLY TO:
 PV DISCONNECT

**WARNING: PHOTOVOLTAIC
 POWER SOURCE**

REQ'D BY: NEC 690.31(G)(3) **C**
 APPLY TO:
 RACEWAYS, CABLE TRAYS,
 OTHER WIRING METHODS, AND
 ENCLOSURES THAN CONTAIN
 PV SYSTEM DC CONDUCTORS

**WARNING
 POWER SOURCE OUTPUT
 CONNECTION. DO NOT
 RELOCATE THIS
 OVERCURRENT DEVICE**

REQ'D BY: NEC 705.12(B)(2)(3)(b) **D**
 APPLY TO:
 DISTRIBUTION EQUIPMENT
 ADJACENT TO BACK-FED BREAKER

2" ADDRESS NUMBERS

REQ' BY: AHJ **E**
 APPLY TO:
 REVENUE METER SOCKET
 (IF APPLICABLE)

REVENUE METER

REQ'D BY: AHJ **F**
 APPLY TO:
 REVENUE METER SOCKET
 (IF APPLICABLE)

MONITORING

REQ'D BY: FREEDOM SOLAR **G**
 APPLY TO:
 MONITORING DEVICE ENCLOSURE

**RAPID SHUTDOWN SWITCH
 FOR SOLAR PV SYSTEM**

REQ'D BY: NEC 690.56(C)(2) **H**
 APPLY TO:
 PV DISCONNECT

**PHOTOVOLTAIC SYSTEM
 AC DISCONNECT
 OPERATING CURRENT: 30.40A
 OPERATING VOLTAGE: 240 VAC**

REQ'D BY: 690.56(1)(a) **J**
 APPLY TO:
 PV DISCONNECT

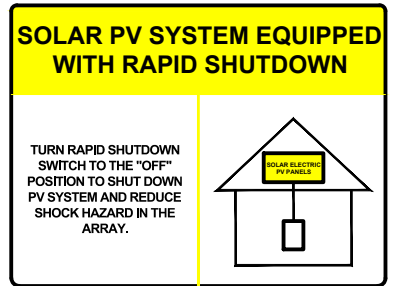

REQ'D BY: NEC 690.56(C)(1)(a) **K**
 APPLY TO:
 MAIN DISTRIBUTION PANEL

CAUTION
 POWER TO THIS BUILDING IS ALSO SUPPLIED FROM THE FOLLOWING SOURCES WITH DISCONNECTS AS SHOWN:

- UTILITY SUPPLY & CUSTOMER SERVICE PANEL
- PV AC DISCONNECT
- RAPID SHUTDOWN SWITCH

FRONT

REQ'D BY: 705.10 **L**
 APPLY TO:
 MAIN DISTRIBUTION PANEL
 (*ONLY REQUIRED IF PV SYSTEM DISCONNECT IS NOT GROUPED WITH MAIN SERVICE DISCONNECT)
SEE SHEET PV-6 FOR SITE SPECIFIC LABELS

CAUTION:
MULTIPLE SOURCES OF POWER
LOCATION OF EACH POWER SOURCE
DISCONNECTING MEANS SHOWN BELOW

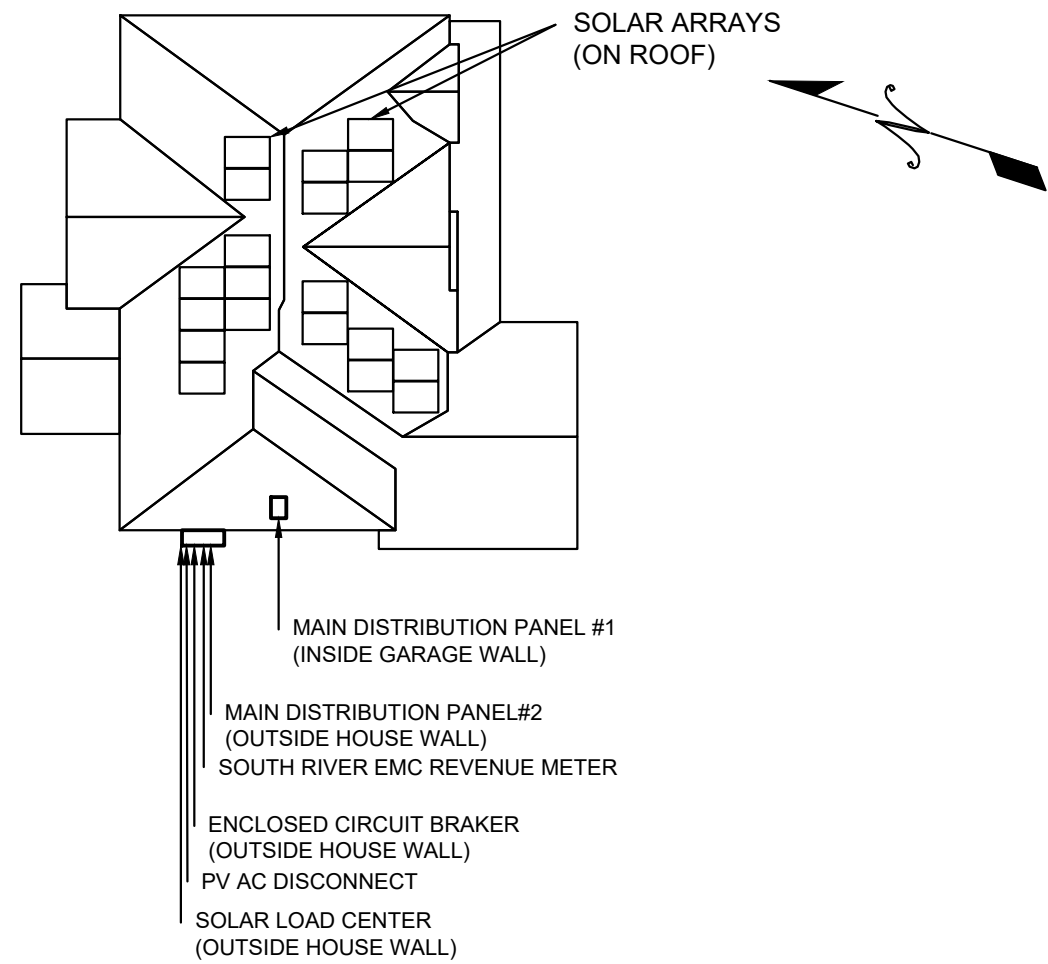

QUESTIONS, CALL:
 800-504-2337
www.freedomsolarpower.com

FREEDOM
SOLAR POWER
 105 MICAHS WAY NORTH
 PROJECT ID: 115404

CONTRACTOR

FREEDOM
SOLAR POWER
 FREEDOM SOLAR LLC
 4801 FREDRICH LN, STE 100
 AUSTIN, TX 78744
 512-759-8313
 TECL # 28621

REVISIONS

DESCRIPTION	DATE	REV
DESIGN PACKET	08/16/2024	-

PE STAMP

PROJECT NAME

SIGFREDO MATOS RODRIGUEZ
 105 MICAHS WAY NORTH
 SPRING LAKE, NORTH
 CAROLINA, 28390
 (706) 691-1266
 PROJECT ID: 115404

SHEET NAME

**SITE
 DIRECTORY
 PLACARD**

SHEET SIZE

**ANSI B
 11" x 17"**

SHEET NUMBER

PV-7

USE THE SAFETY SYMBOL KEY TO DRAW IN THE CONTROLLED ACCESS ZONE (CAZ), LADDER PLACEMENT, METER LOCATION, FALL PROTECTION ANCHOR POINT, AND ANY OTHER HAZARD.

HARD HAT IS REQUIRED AT ALL TIMES IN CAZ

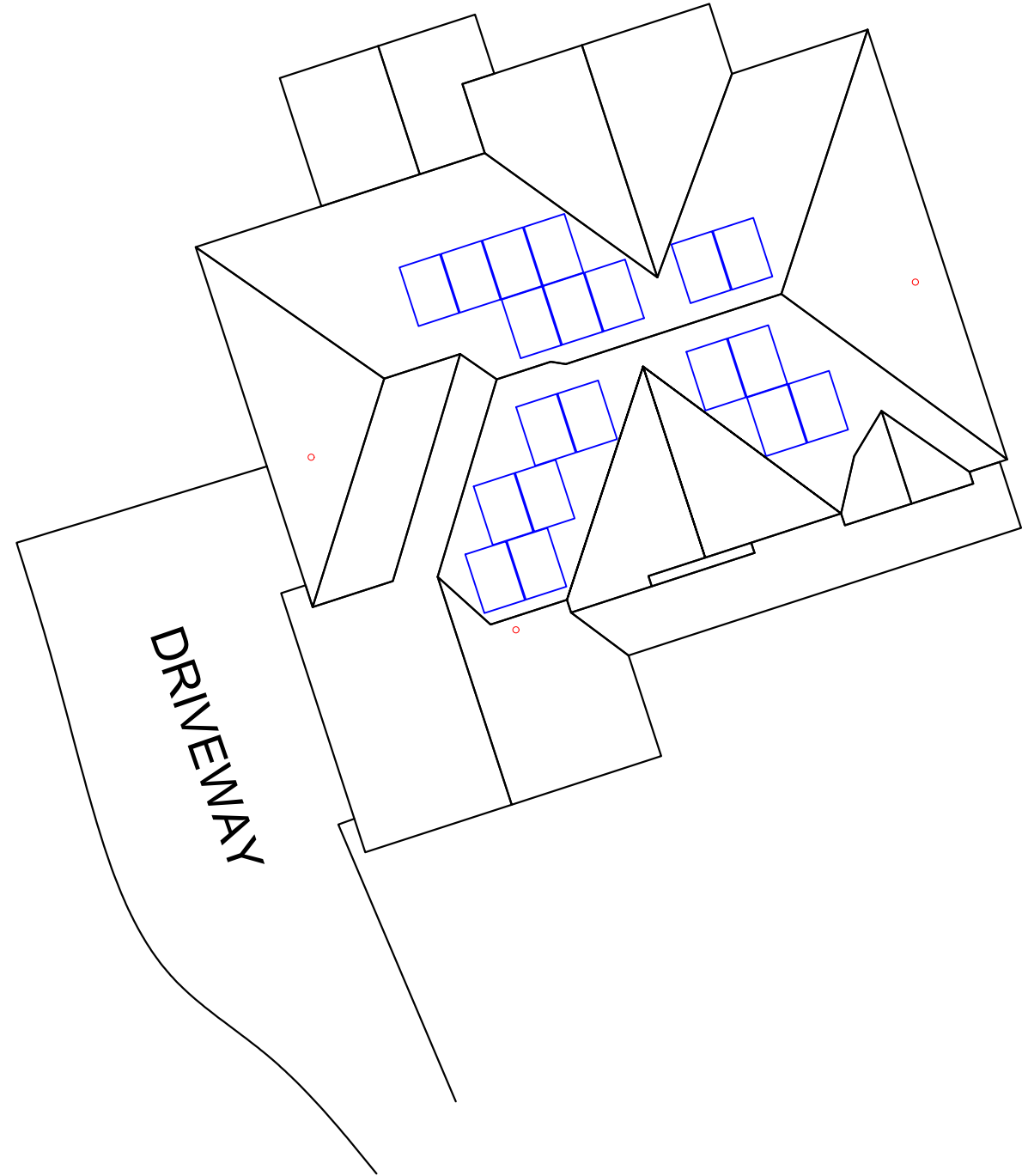

SAFETY SYMBOL KEY

- CAZ
- L** LADDER
- M** METER
- ==== POWER LINES
- R** RESTRAINT ANCHOR
- A** ARREST ANCHOR



CONTRACTOR

FREEDOM SOLAR POWER
 FREEDOM SOLAR LLC
 4801 FREDRICH LN, STE 100
 AUSTIN, TX 78744
 512-759-8313
 TECL # 28621

REVISIONS

DESCRIPTION	DATE	REV
DESIGN PACKET	08/16/2024	-

PE STAMP

CONDUCT SAFETY MEETING WITH ALL CREW MEMBERS ON SITE AT THE BEGINNING OF EACH JOB. USE SIGN IN SHEET BELOW.

1. _____
2. _____
3. _____
4. _____
5. _____

PROJECT NAME

SIGFREDO MATOS RODRIGUEZ
 105 MICAH'S WAY NORTH
 SPRING LAKE, NORTH CAROLINA, 28390
 (706) 691-1266
 PROJECT ID: 115404

SHEET NAME

SAFETY PLAN

SHEET SIZE

**ANSI B
 11" x 17"**

SHEET NUMBER

PV-8

COMPETENT PERSON: _____ JOB START DATE: _____



420–440 W Residential AC Panel

Built specifically for use with the SunPower Equinox® system, a fully integrated solar solution that's designed, engineered, and warranted by one company.



Highest Power AC Density Available

The patented, solid-copper foundation Gen 6 cell is over 5% larger than prior generations, delivering the highest-efficiency AC solar panel available.¹

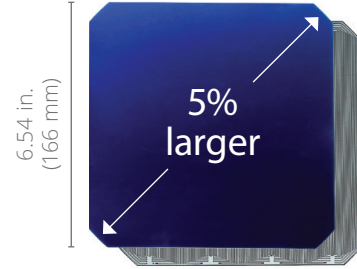
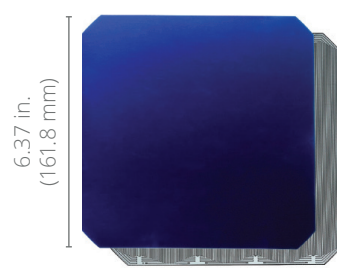

Highest Lifetime Energy and Savings

Designed to deliver 60% more energy over 25 years in real-world conditions like partial shade and high temperatures.²

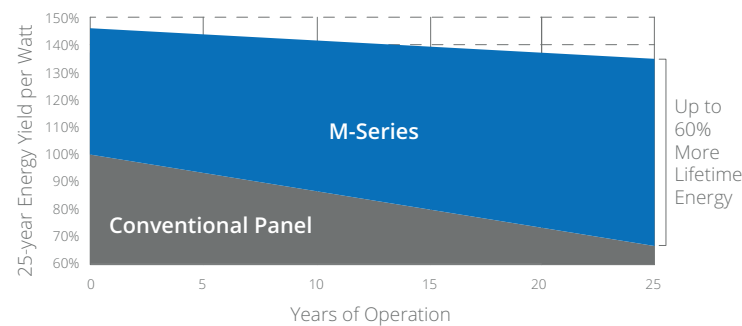

SunPower Complete Confidence Warranty

Every part of the SunPower Equinox® system is designed and built by one company. We stand behind our panels and microinverters with an industry-leading 25-year Combined Power and Product Warranty.

Part of the SunPower Equinox® Solar System

- Compatible with mySunPower® for system performance monitoring



- Sleek design and low-profile mounting system for a streamlined appearance
- Panels tested for reliability up to three times more than the industry standard to ensure long-term performance³



Factory-integrated Microinverter

- Highest-power integrated AC panel in solar
- Engineered and calibrated by SunPower for SunPower AC panels

AC Electrical Data		
Inverter Model: Type H (Enphase IQ7HS)	@240 VAC	@208 VAC
Peak Output Power (VA)	384	369
Max. Continuous Output Power (VA)	384	369
Nom. (L-L) Voltage/Range ⁴ (V)	240 / 211–264	208 / 183–229
Max. Continuous Output Current (Arms)	1.60	1.77
Max. Units per 20 A (L-L) Branch Circuit ⁵	10	9
CEC Weighted Efficiency	97.0%	96.5%
Nom. Frequency	60 Hz	
Extended Frequency Range	47–68 Hz	
AC Short Circuit Fault Current Over 3 Cycles	4.82 A rms	
Overvoltage Class AC Port	III	
AC Port Backfeed Current	18 mA	
Power Factor Setting	1.0	
Power Factor (adjustable)	0.85 (inductive) / 0.85 (capacitive)	

DC Power Data					
	SPR-M440-H-AC	SPR-M435-H-AC	SPR-M430-H-AC	SPR-M425-H-AC	SPR-M420-H-AC
Nom. Power ⁷ (Pnom) W	440	435	430	425	420
Power Tolerance	+5/-0%				
Module Efficiency	22.8%	22.5%	22.3%	22.0%	21.7%
Temp. Coef. (Power)	-0.29% / °C				
Shade Tolerance	Integrated panel-level max. power point tracking				

Tested Operating Conditions	
Operating Temp.	-40° F to +185°F (-40°C to +85°C)
Max. Ambient Temp.	122°F (50°C)
Max. Test Load ⁹	Wind: 125 psf, 6000 Pa, 611 kg/m ² back Snow: 187 psf, 9000 Pa, 917 kg/m ² front
Max. Design Load	Wind: 75 psf, 3600 Pa, 367 kg/m ² back Snow: 125 psf, 6000 Pa, 611 kg/m ² front
Impact Resistance	1 inch (25 mm) diameter hail at 52 mph (23 m/s)

Mechanical Data	
Solar Cells	66 Maxeon Gen 6
Front Glass	High-transmission tempered glass with anti-reflective coating
Environmental Rating	Outdoor rated
Frame	Class 1 black anodized (highest AAMA rating)
Weight	48 lb (21.8 kg)
Recommended Max. Module Spacing	1.3 in. (33 mm)

- SunPower M-440 panels offer the highest efficiency of any commercially available solar panel based on the top 20 manufacturers by market share in the U.S. (per Wood Mackenzie US PV Leaderboard Q3 2022 report).
- SunPower 435 W, 22.5% efficient, compared to a Conventional Panel on same-sized arrays (260 W, 16% efficient, approx. 1.6 m²), 7.9% more energy per watt (based on PVsyst pan files for avg. US climate), 0.5%/yr slower degradation rate (Jordan, et. al. "Robust PV Degradation Methodology and Application." PVSC 2018).
- SunPower works with third-party laboratories and companies to complete testing on panels they offer. Standard testing, as defined by those third parties, includes reliability tests of Damp Heat (DH1000), Humidity Freeze (HF10) and Thermal Cycling (TC200).
- Voltage range can be extended beyond nominal if required by the utility.
- Limits may vary. Refer to local requirements to define the number of microinverters per branch in your area.
- Factory set to IEEE 1547-2018 default settings. CA Rule 21 default settings profile set during commissioning.
- Standard Test Conditions (1000 W/m² irradiance, AM 1.5, 25°C). All DC voltage is fully contained within the module.
- UL Listed as PVRSE and conforms with NEC 2017, NEC 2020, and NEC 2023 690.12 and C22.1-2015 Rule 64-218 Rapid Shutdown of PV Systems, for AC and DC conductors; when installed according to manufacturer's instructions.
- Please read the safety and installation instructions for more information regarding load ratings and mounting configurations.

See www.sunpower.com/company for more reference information. Specifications included in this datasheet are subject to change without notice.

© 2023 SunPower Corporation. All rights reserved. SUNPOWER, the SUNPOWER logo, SUNPOWER EQUINOX and MYSUNPOWER are registered trademarks of SunPower Corporation in the U.S.

Warranties, Certifications, and Compliance	
Warranties	<ul style="list-style-type: none"> 25-year limited power warranty 25-year limited product warranty
Certifications and Compliance	<ul style="list-style-type: none"> UL 1741 AC Module (Type 2 fire rated) UL 61730 UL 62109-1 / IEC 62109-2 FCC Part 15 Class B ICES-0003 Class B CAN/CSA-C22.2 NO. 107.1-01 CA Rule 21 (UL 1741 SA) (includes Volt/Var and Reactive Power Priority) UL Listed PV Rapid Shutdown Equipment⁸ IEEE 1547-2018 (UL 1741-SB)⁶ <p>Enables installation in accordance with:</p> <ul style="list-style-type: none"> NEC 690.6 (AC module) NEC 690.12 Rapid Shutdown (inside and outside the array) NEC 690.15 AC Connectors, 690.33(A)-(E)(1) <p>When used with AC module Q Cables and accessories (UL 6703 and UL 2238)⁸:</p> <ul style="list-style-type: none"> Rated for load break disconnect
PID Test	1000 V; IEC 62804

Packaging Configuration	
Panels per pallet	25
Packaging box dimensions	75.4 × 42.2 × 48.0 in. (1915 × 1072 × 1220 mm)
Pallet gross weight	1300.7 lb (590 kg)
Pallets per container	32
Net weight per container	41,623 lb (18,880 kg)

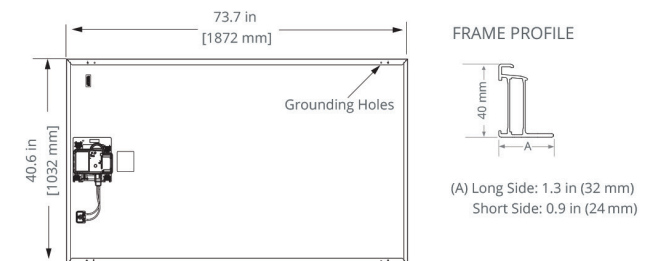

Please read the safety and installation instructions for details.

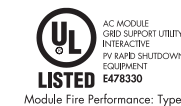

539973 RevE
September 2023

Enphase IQ7HS Microinverter

The high-powered smart grid-ready **Enphase IQ7HS Microinverter™** with integrated MC4 connectors dramatically simplify the installation process while achieving the highest system efficiency.

The IQ Series Microinverters extend the reliability standards set forth by previous generations and undergo over a million hours of power-on testing, enabling Enphase to provide an industry-leading warranty of up to 25 years.



Easy to Install

- Lightweight and simple
- Faster installation with improved, lighter two-wire cabling
- Built-in rapid shutdown compliant (NEC 2014, 2017 & 2020)

Efficient and Reliable

- Highest CEC efficiency of 97.0%
- More than a million hours of testing
- Class II double-insulated enclosure
- UL listed

Smart Grid Ready

- Complies with advanced grid support, voltage and frequency ride-through requirements
- Remotely updates to respond to changing grid requirements
- Configurable for varying grid profiles
- Meets CA Rule 21 (UL 1741-SA)

Enphase IQ7HS Microinverter

INPUT DATA (DC)	IQ7HS-66-M-US	
Commonly used module pairings ¹	320W - 460W	
Module compatibility ²	66 cell/120 half-cell/132 half-cell	
Maximum input DC voltage	59V	
Peak power tracking voltage	38V - 43V	
Operating range	20V - 59V	
Min/Max start voltage	30V/59V	
Max DC short circuit current (module Isc)	15A	
Overvoltage class DC port	II	
DC port backfeed current	0A	
PV array configuration	1 x 1 ungrounded array; No additional DC side protection required; AC side protection requires max 20A per branch circuit	

OUTPUT DATA (AC)	@240 VAC	@208 VAC
Peak output power	384 VA	369 VA
Maximum continuous output power	384 VA	369 VA
Nominal (L-L) voltage/range ³	240V/211-264V	208V/183-229V
Maximum continuous output current	1.60A (240V)	1.77A (208V)
Nominal frequency	60 Hz	60 Hz
Extended frequency range	47 Hz to 68 Hz	47 Hz to 68 Hz
AC short circuit fault current over 3 cycles	4.82A	4.82 A
Maximum units per 20 A (L-L) branch circuit ⁴	10	9
Overvoltage class AC port	III	III
AC port backfeed current	18 mA	18 mA
Power factor setting	1.0	1.0
Power factor (adjustable)	0.85 leading ...0.85 lagging	0.85 leading ...0.85 lagging

EFFICIENCY	@240V	@208V
CEC weighted efficiency	97.0 %	96.5 %

MECHANICAL DATA	
Ambient temperature range	-40°C to +60°C
Relative humidity range	4% to 100% (condensing)
Connector type	Staubli made MC4
Dimensions (WxHxD)	212 mm x 175 mm x 30.2 mm (without bracket)
Weight	1.08 kg (2.38 lbs)
Cooling	Natural convection - No fans
Approved for wet locations	Yes
Pollution degree	PD3
Enclosure	Class II, corrosion resistant polymeric enclosure
Environmental category/UV exposure rating	NEMA type 6/outdoor
Altitude	2000 m

FEATURES	
Communication	Power Line Communication (PLC)
Disconnecting means	The AC and DC connectors have been evaluated and approved by UL for use as the load-break disconnect means required by NEC 690 and C22.1-2018 Rule 64-220.
Compliance	CA Rule 21 (UL1741-SA), IEEE 1547:2018 (UL1741-SB), UL 62109-1, FCC Part 15 Class B, HECO v1.1, ICES-0003 Class B, CAN/CSA-C22.2 NO. 107.1-01 This product is UL listed as PV Rapid Shutdown Equipment and conforms with NEC 2014, NEC 2017, and NEC 2020 section 690.12 and C22.1-2018 Rule 64-218 Rapid Shutdown of PV Systems, for AC and DC conductors, when installed according to manufacturer's instructions.

1. No enforced DC/AC ratio. See the compatibility calculator at <https://enphase.com/en-us/support/module-compatibility>.
 2. Provided the module is compatible with all other parameters in the datasheet.
 3. Nominal voltage range can be extended beyond nominal if required by the utility.
 4. Limits may vary. Refer to local requirements to define the number of microinverters per branch in your area.





SunPower® EnergyLink™ | Residential and Commercial PVS6

Improve Support, Reduce Maintenance Costs

An intuitive monitoring website enables you to:

- See a visual map of customer sites
- Remotely manage hundreds of sites
- Receive elective system reports
- Locate system issues and remotely diagnose
- Diagnose issues online
- Drill down for the status of individual devices

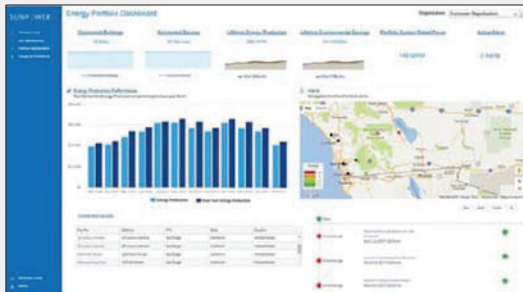

Add Value for Customers

With the SunPower Monitoring System customers can:

- See what their solar system produces each day, month, or year
- Optimize their solar investment and save on energy expenses
- See their energy use and estimated bill savings
- See their solar system's performance using the SunPower monitoring website or mobile app



SunPower EnergyLink—Plug-and-Play Installation

This complete solution for residential and commercial monitoring and control includes the SunPower® PV Supervisor 6 (PVS6) which improves the installation process, overall system reliability, and customer experience.

- Compact footprint for improved aesthetics
- Robust cloud connectivity and comprehensive local connectivity
- Flexible configuration of devices during installation
- Consumption metering
- Revenue-grade production metering (pending)
- Web-based commissioning
- Remote diagnostics of PVS6 and inverters
- Durable UL Type 3R enclosure reduces maintenance costs
- Easy integration with SunPower eBOS



Robust Cloud Connectivity

Multiple options to maintain optimal connectivity:

- Hardwired Ethernet
- Wi-Fi
- Cellular backup



SunPower® EnergyLink™ | Residential and Commercial PVS6

SunPower Monitoring Websites

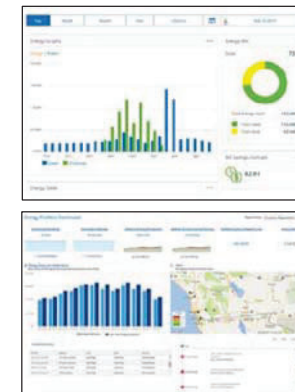

PVS6



SunPower AC Modules

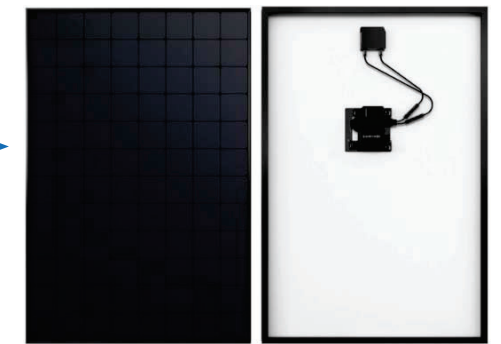

Multiple communication options include Ethernet, Wi-Fi, and cellular.

Site Requirements	
Number of SunPower AC modules supported per PVS6	85
Internet access	High-speed internet access via accessible router or switch
Power	<ul style="list-style-type: none"> • 100–240 VAC (L–N), 50 or 60 Hz • 208 VAC (L–L in 3-phase), 60 Hz

Operating Conditions	
Temperature	–22°F to +140°F (–30°C to +60°C)
Humidity (maximum)	95%, non-condensing

Mechanical	
Weight	5.5 lbs (2.5 kg)
Dimensions	11.8 × 8.0 × 4.2 in. (30.5 × 20.5 × 10.8 cm)
Enclosure rating	UL50E Type 3R

Communication	
RS-485	Inverters and meters
Integrated Metering	<ul style="list-style-type: none"> • One channel of revenue-grade production metering • Two channels of consumption metering
Ethernet	1 LAN (or optional WAN) port
PLC	PLC for SunPower AC modules
Wi-Fi	802.11b/g/n 2.4 GHz and 5 GHz
Cellular	LTE Cat-M1/3G UMTS
ZigBee	IEEE 802.15.4 MAC, 2.4GHz ISM band
Data Storage	60 days
Upgrades	Automatic firmware upgrades

Web and Mobile Device Support	
Customer site	monitor.us.sunpower.com
Partner site	pvsmgmt.us.sunpower.com
Browsers	Firefox, Safari, and Chrome
Mobile devices	iPhone®, iPad®, and Android™
Customer app	<ol style="list-style-type: none"> 1. Create account online at: monitor.us.sunpower.com. 2. On a mobile device, download the SunPower Monitoring app from Apple App Store™ or Google Play™ store. 3. Sign in using account email and password.

Warranty and Certifications	
Warranty	10-year Limited Warranty
Certifications	UL, cUL, CE, UL 61010-1 and -2, FCC Part 15 (Class B)



© 2019 SunPower Corporation. All rights reserved. SUNPOWER, SUNPOWER logo, and ENERGYLINK are trademarks or registered trademarks of SunPower Corporation. iPhone and iPad are registered trademarks of Apple Inc. Android and Google Play are trademarks of Google Inc. All other trademarks are the property of their respective owners. Specifications included in this datasheet are subject to change without notice.

530536 RevC



SunPower® InvisiMount™ | Residential Mounting System

Simple and Fast Installation

- Integrated module-to-rail grounding
- Pre-assembled mid and end clamps
- Levitating mid clamp for easy placement
- Mid clamp width facilitates consistent, even module spacing
- UL 2703 Listed integrated grounding

Flexible Design

- Addresses sloped and low-sloped residential roofs
- Design in landscape and portrait with up to 8' rail span
- Pre-drilled rails and rail splice
- Rails enable easy obstacle management

Customer-Preferred Aesthetics

- Best-in-class system aesthetics
- Black anodized components
- Low-profile mid clamps and capped, flush end clamps

Part of Superior System

- Best-in-class system reliability and aesthetics
- Optional rooftop transition flashing, rail-mounted J-box, and wire management rail clips
- Combine with SunPower modules and mySunPower® monitoring app

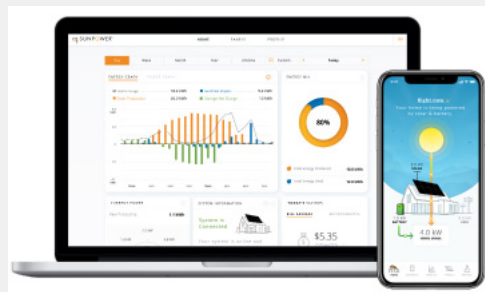

Elegant Simplicity

SunPower® InvisiMount™ is a SunPower-designed rail-based mounting system. The InvisiMount system addresses residential sloped roofs and combines faster installation time, design flexibility, and superior aesthetics.

Classic InvisiMount is specifically envisioned and engineered to pair with SunPower modules; Universal InvisiMount is compatible with a wide range of modules. The resulting system-level approach amplifies the installation and aesthetic benefits—for homeowners and for installers.



Intertek
5024883
Conf. To UL STD 2703
Class A Fire Rating

sunpower.com

SunPower® InvisiMount™ | Residential Mounting System

InvisiMount Components

Classic InvisiMount



Universal InvisiMount



InvisiMount Component Details		
Classic mid clamp	Black oxide stainless steel 300 series	63 g (2.2 oz)
Universal mid clamp	Black anodized aluminum 6000 series	60 g (2.1 oz)
Classic end clamp	Black anodized aluminum 6000 series	110 g (3.88 oz)
Universal end clamp	Black anodized aluminum 6000 series	103 g (3.63 oz)
Rail	Black anodized aluminum 6000 series	830 g/m (9 oz/ft)
Rail splice	Aluminum alloy 6000 series	830 g/m (9 oz/ft)
Rail bolt	M10-1.5 x 25 mm; custom T-head SS304	18 g (0.63 oz)
Rail nut	M10-1.5; DIN 6923 SS304	nominal
Ground lug assembly	SS304; A2-70 bolt; tin-plated copper lug	106.5 g (3.75 oz)
Row-to-row grounding clip	SS 301 with SS 304 M6 bolts	75 g (2.6 oz)
Row-to-row grounding jumper	Stainless steel 300 series	10 g (0.35 oz)
Row-to-row spacer	Black POM-grade plastic	5 g (0.18 oz)

Roof Attachment BOM	
• InvisiMount Comp Shingle Attachment with Pegasus	
• InvisiMount Flat Tile Replacement Attachment with Pegasus	
• InvisiMount S-Tile Replacement Attachment with Pegasus	
• InvisiMount W-Tile Replacement Attachment with Pegasus	

InvisiMount Warranties And Certifications	
Warranties	• 25-year product warranty • 5-year finish warranty
Certifications	• UL 2703 Listed • Class A Fire Rated

InvisiMount Operating Conditions	
Temperature	-40°C to 90°C (-40°F to 194°F)

Roof Attachment Hardware Warranties	
Refer to roof attachment hardware manufacturer's documentation.	

InvisiMount Component LRFD Capacities ²		
Classic Mid clamp	Uplift	664 lbf
	Shear	540 lbf
Universal Mid clamp	Uplift	962 lb
	Shear	437 lb
Classic End clamp	Uplift	899 lbf
	Shear	220 lbf
Universal End clamp	Uplift	605 lb
	Shear	242 lb
Rail	Moment: upward	548 lbf-ft
	Moment: downward	580 lbf-ft
Rail splice	Moment: upward	548 lbf-ft
	Moment: downward	580 lbf-ft
L-foot	Uplift	1000 lbf
	Shear	390 lbf

¹ With Classic InvisiMount, a module frame that is compatible with the InvisiMount system is required for hardware interoperability; modules without this frame may be used with Universal InvisiMount.

² SunPower recommends that all Equinox™, InvisiMount™, and AC module systems always be designed using the InvisiMount Span Tables #524734. If a designer decides to instead use the component capacities listed in this document to design a system, note that the capacities shown are Load and Resistance Factor Design (LRFD) design loads, and are NOT to be used for Allowable Stress Design (ASD) calculations; and that a licensed Professional Engineer (PE) must then stamp all calculations. If you have any questions please contact SunPower Technical Support at 1-855-977-7867.

© 2022 SunPower Corporation. All Rights Reserved. SUNPOWER, the SUNPOWER logo, EQUINOX, and INVISIMOUNT are trademarks or registered trademarks of SunPower Corporation. All other trademarks are the property of their respective owners. Specifications included in this datasheet are subject to change without notice.



INSTAFLASH™

Never Deal With Caulking Again!

Factory-installed, non-hardening sealant



Before InstaFlash Installed:
Sealant is contained above roof surface by a protective cage.



After InstaFlash Installed:
Sealant is compressed to fill all holes and voids.

Protective Cage

Prevents sealant from getting on hands or roof. Collapses upon lag installation.

Effortless Lifetime Roof Protection

The non-hardening sealant completely fills any missed pilot holes, shingle rips, voids, or other potential water ingress points under the entire footprint of the 4.6" wide base.



25-Year Warranty

Manufactured with advanced materials and coatings to outlast the roof itself



Code Compliant

Fully IBC/CBC Code Compliant Exceeds ASCE 7-16 Standards FL Cert of Approval FL41396 UL2703 Certified



Self-Healing

The proprietary non-hardening sealant will flex and reseal over years of thermal expansion and contraction



Larger Spans

The extra-large L-foot and proprietary lag screw result in larger spans between mounts



INSTAFLASH™

1
Drill pilot hole in the center of the rafter using a 7/32" bit.



2
Place the InstaFlash over the pilot hole. **Note:** the direction of the InstaFlash Down arrows should point down the roof.



3
Insert the lag screw through the center hole into the pilot hole.



4
Drive the lag until the InstaFlash is fully seated to the roof.

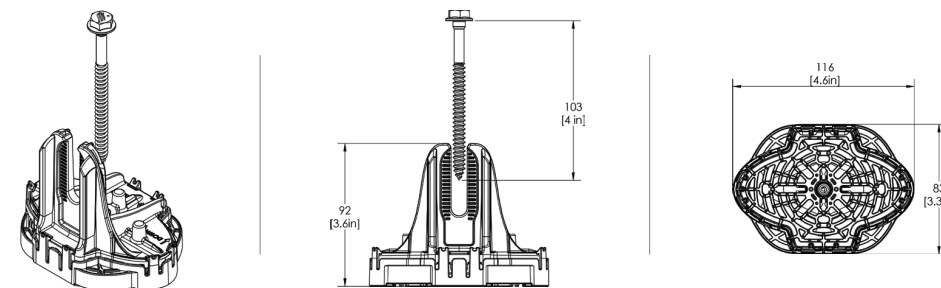

SPECIFICATIONS	INSTAFLASH KITS				
	PIF-RB0	PIF-RBDT	PIF-RBSH	PIF-RM0	PIF-RMDT
Finish	Black			Mill	
Kit Contents	Black InstaFlash, 5/16" x 4.0" SS Lag	Black InstaFlash, 5/16" x 4.0" SS Lag, Dovetail T-bolt w/ Nut	Black InstaFlash, 5/16" x 4.0" SS Lag, M10 Hex Bolt w/ Nut	Mill Insta-Flash, 5/16" x 4.0" SS Lag	Mill InstaFlash, 5/16" x 4.0" SS Lag, Dovetail T-bolt w/ Nut
Attachment Type	Rafter Attached				
Roof Type	Sloped Roof: Composition Shingle, Rolled Asphalt Flat roof: Modified Bitumen Roof, Built-Up Roof				
Sealant Application	Factory Installed				
Installation Temperature	0°F to 170° F				
Cure Time	Instantly Waterproof; Non-hardening				
Service Temperature	-40°F to 195° F				
Certifications	IBC, ASCE/SEI 7-16, FL Cert of Approval FL41396, TAS 100(A), UL2703				
Install Application	Most Railed Systems, Pegasus Tilt Leg Kit				
Kit Quantity	24				
Boxes per Pallet	36				

US Patents Pending. All rights reserved. ©2023 Pegasus Solar Inc.



SCAN FOR INSTALLATION VIDEO



SCAN FOR FREE TRIAL

Eaton general duty cartridge fuse safety switch

DG222NRB

UPC:782113144221

Dimensions:

- **Height:** 14.37 IN
- **Length:** 7.35 IN
- **Width:** 8.4 IN

Weight:10 LB

Notes:Maximum hp ratings apply only when dual element fuses are used. 3-Phase hp rating shown is a grounded B phase rating, UL listed.

Warranties:

- Eaton Selling Policy 25-000, one (1) year from the date of installation of the Product or eighteen (18) months from the date of shipment of the Product, whichever occurs first.

Specifications:

- **Type:** General duty, cartridge fused
- **Amperage Rating:** 60A
- **Enclosure:** NEMA 3R
- **Enclosure Material:** Painted galvanized steel
- **Fuse Class Provision:** Class H fuses
- **Fuse Configuration:** Fusible with neutral
- **Number Of Poles:** Two-pole
- **Number Of Wires:** Three-wire
- **Product Category:** General duty safety switch
- **Voltage Rating:** 240V

Supporting documents:

- [Eatons Volume 2-Commercial Distribution](#)
- [Eaton Specification Sheet - DG222NRB](#)

Certifications:

- UL Listed

Product compliance: No Data



Eaton general duty non-fusible safety switch

DG222URB

UPC:782113144238

Dimensions:

- **Height:** 14.38 IN
- **Length:** 7.38 IN
- **Width:** 8.69 IN

Weight:9 LB

Notes:WARNING! Switch is not approved for service entrance unless a neutral kit is installed.

Warranties:

- Eaton Selling Policy 25-000, one (1) year from the date of installation of the Product or eighteen (18) months from the date of shipment of the Product, whichever occurs first.

Specifications:

- **Type:** Non-fusible, single-throw
- **Amperage Rating:** 60A
- **Enclosure:** NEMA 3R, Rainproof
- **Enclosure Material:** Painted galvanized steel
- **Fuse Configuration:** Non-fusible
- **Number Of Poles:** Two-pole
- **Number Of Wires:** Two-wire
- **Product Category:** General duty safety switch
- **Voltage Rating:** 240V

Supporting documents:

- [Eatons Volume 2-Commercial Distribution](#)
- [Eaton Specification Sheet - DG222URB](#)

Certifications:

- UL Listed

Product compliance: No Data



FRN-R (250 V) and FRS-R (600 V) Class RK5 Fusetron™ energy efficient, dual-element, time-delay fuses

Dual-element, time-delay Class RK5 fuses. FRN-R — 10 seconds (minimum) at 500% rated amps (8 seconds for 0-30 A sizes). FRS-R — 10 seconds (minimum) at 500% rated amps. FRN-R and FRS-R available with optional indication on select ratings (see catalog numbers table). For superior electrical protection, Eaton recommends upgrading to Bussmann series Low-Peak LPN-RK (250 V) or LPS-RK (600 V) fuses, see pages 1-24 to 1-26. For dimensions, see page 1-3.

Ratings

- Volts
 - FRN-R
 - 250 Vac (or less)
 - 125 Vdc (1/10-60 A, 110-200 A)
 - 250 Vdc (225-600 A)
 - FRS-R
 - 600 Vac (or less)
 - 300 Vdc 1/10-30 A, 65-600 A
 - 250 Vdc* 35-60 A
- Amps 1/10-600 A
- IR
 - 200 kA RMS Sym.
 - 20 kA DC



* Does not apply to indicating versions.

Agency information

- FRN-R
 - UL Listed, Std 248-12, Class RK5, Guide JDDZ, File E4273
 - CSA Certified, Class 1422-01, File 53787
- FRS-R
 - UL Listed, Std 248-12, Class RK5, Guide JDDZ, File E4273
 - CSA Certified, Class 1422-02, File 53787
- CE

Features

- Separate overload and short-circuit elements provide time-delay for sizing as close as 125% of motor FLA
- 2:1 selective coordination amp ratio (within the Fusetron RK5 fuse family) helps prevent overcurrent events from opening upstream Fusetron fuses
- Insulated end caps for 225-600 A (FRN-R) and 65-600 A (FRS-R) fuses reduces exposure to live parts and extends air gap to distance between blades of adjacent mounted fuses or to housing

Typical applications

- Power panelboards
- Motor control centers
- Combination starters
- Machinery disconnects

Catalog no. (amps)

250 V FRN-R			
FRN-R-1/10	FRN-R-2	FRN-R-10*	FRN-R-100
FRN-R-1/8	FRN-R-2-1/4	FRN-R-12*	FRN-R-110
FRN-R-15/100	FRN-R-2-1/2	FRN-R-15*	FRN-R-125
FRN-R-2/10	FRN-R-2-8/10	FRN-R-17-1/2*	FRN-R-150
FRN-R-1/4	FRN-R-3	FRN-R-20*	FRN-R-175
FRN-R-3/10	FRN-R-3-2/10	FRN-R-25*	FRN-R-200
FRN-R-4/10	FRN-R-3-1/2	FRN-R-30*	FRN-R-225
FRN-R-1/2	FRN-R-4	FRN-R-35*	FRN-R-250
FRN-R-6/10	FRN-R-4-1/2	FRN-R-40*	FRN-R-300
FRN-R-8/10	FRN-R-5	FRN-R-45*	FRN-R-350
FRN-R-1	FRN-R-5-6/10	FRN-R-50*	FRN-R-400
FRN-R-1-1/8	FRN-R-6	FRN-R-60*	FRN-R-450
FRN-R-1-1/4	FRN-R-6-1/4	FRN-R-70	FRN-R-500
FRN-R-1-4/10	FRN-R-7	FRN-R-75	FRN-R-600
FRN-R-1-1/2	FRN-R-7-1/2	FRN-R-80	
FRN-R-1-6/10	FRN-R-8*	FRN-R-85	
FRN-R-1-8/10	FRN-R-9*	FRN-R-90	
600 V FRS-R			
FRS-R-1/10	FRS-R-2	FRS-R-10*	FRS-R-100
FRS-R-1/8	FRS-R-2-1/4	FRS-R-12*	FRS-R-110
FRS-R-15/100	FRS-R-2-1/2	FRS-R-15*	FRS-R-125
FRS-R-2/10	FRS-R-2-8/10	FRS-R-17-1/2*	FRS-R-150
FRS-R-1/4	FRS-R-3	FRS-R-20*	FRS-R-175
FRS-R-3/10	FRS-R-3-2/10	FRS-R-25*	FRS-R-200
FRS-R-4/10	FRS-R-3-1/2	FRS-R-30*	FRS-R-225
FRS-R-1/2	FRS-R-4	FRS-R-35*	FRS-R-250
FRS-R-6/10	FRS-R-4-1/2	FRS-R-40*	FRS-R-300
FRS-R-8/10	FRS-R-5	FRS-R-45*	FRS-R-350
FRS-R-1	FRS-R-5-6/10	FRS-R-50*	FRS-R-400
FRS-R-1-1/8	FRS-R-6*	FRS-R-60*	FRS-R-450
FRS-R-1-1/4	FRS-R-6-1/4*	FRS-R-65	FRS-R-500
FRS-R-1-4/10	FRS-R-7*	FRS-R-70	FRS-R-600
FRS-R-1-1/2	FRS-R-7-1/2*	FRS-R-75	
FRS-R-1-6/10	FRS-R-8*	FRS-R-80	
FRS-R-1-8/10	FRS-R-9*	FRS-R-90	

* Available with indication To order, place "ID" at the end of the catalog number. Example: FRN-R-30ID or FRS-R-7ID.

Recommended blocks for Class RK5 fuses, see page 1-2.

Low voltage, branch circuit fuses

**Data sheet no. FRN-R; 1019 (up to 60 A), 1020 (70-600 A)
FRS-R 1017 (up to 60 A), 1018 (70-600 A)**

Eaton CH main lug loadcenter

CH8L125RP

UPC:782114190548

Dimensions:

- **Height:** 3.69 IN
- **Length:** 13 IN
- **Width:** 11 IN

Weight: 12 LB

Notes: Ground bar kits priced separately. Suitable for use as service equipment when not more than two service disconnecting mains are provided or when not used as a lighting and appliance panelboard.

Warranties:

- Limited lifetime

Specifications:

- **Special Features:** Cover included
- **Type:** Main lug only
- **Amperage Rating:** 125A
- **Box Size:** 7r
- **Bus Material:** Copper
- **Enclosure:** NEMA 3R
- **Enclosure Material:** Metallic
- **Feed Type:** Overhead
- **Main Circuit Breaker:** CH
- **Number Of Circuits:** 8
- **Number Of Wires:** Three-wire
- **Phase:** Single-phase
- **Voltage Rating:** 120/240V, 208Y/120, 240V
- **Wire Size:** #6-1/0 AWG

Supporting documents:

- [Type CH Circuit Breakers and Loadcenters](#)
- [Loadcenters and Circuit Breakers](#)
- [Eatons Volume 1-Residential and Light Commercial](#)



Eaton CH main lug loadcenter

CH12L125R

UPC:782113097381

Dimensions:

- **Height:** 5.19 IN
- **Length:** 16.75 IN
- **Width:** 14.31 IN

Weight: 15.8 LB

Notes: Suitable for use as service equipment when not more than six service disconnecting mains are provided or when not used as a lighting and appliance panelboard. Rainproof panels are furnished with hub closure plates. For rainproof hubs.

Warranties:

- Limited lifetime

Specifications:

- **Special Features:** Cover included
- **Type:** Main lug only
- **Amperage Rating:** 125A
- **Box Size:** B
- **Bus Material:** Copper
- **Enclosure:** NEMA 3R
- **Enclosure Material:** Metallic
- **Feed Type:** Overhead
- **Main Circuit Breaker:** CH
- **Number Of Circuits:** 12
- **Number Of Wires:** Three-wire
- **Phase:** Single-phase
- **Voltage Rating:** 120/240V
- **Wire Size:** #6-2/0 AWG

Supporting documents:

- [Dimensional Drawing - CH 3/4 LOADCENTER, MAIN LUG ONLY, OUTDOOR NEMA 3R, 120/240 VAC, 1 PH](#)



1.4 Listings, Compatibility, and Classification

The SunPower InvisiMount Residential Mounting System is UL 2703 Listed. The InvisiMount Listing **includes** the following modules, which have been tested for grounding and mechanical load with the InvisiMount system.

For Classic InvisiMount certification information, refer to UL at their site <https://www.ul.com> or the at the UL portal <https://www.ul.com/resources/apps/myul-client-portal> and view *File E314938* and *File E466981*. For Universal InvisiMount certification information, refer to Intertek at [https://ramuk.intertekconnect.com/WebClients/ITS/DLP/products.nsf/\\$\\$Search?OpenForm](https://ramuk.intertekconnect.com/WebClients/ITS/DLP/products.nsf/$$Search?OpenForm) and view *Control Number 5024883*.

SunPower DC Modules	SunPower AC Modules	
<ul style="list-style-type: none"> • SPR-A400-BLK-DC • SPR-A400-DC • SPR-A410-DC • SPR-E19-320 • SPR-E20-327 • SPR-X21-335-BLK • SPR-X21-350-BLK • SPR-X21-345 • SPR-X22-360 • SPR-X22-370 	<ul style="list-style-type: none"> • SPR-A400-BLK-G-AC • SPR-A390-G-AC • SPR-A400-G-AC • SPR-A410-G-AC • SPR-A415-G-AC • SPR-A425-G-AC • SPR-M415-BLK-H-AC • SPR-M425-BLK-H-AC • SPR-M420-H-AC • SPR-M435-H-AC • SPR-M440-H-AC 	<ul style="list-style-type: none"> • SPR-X22-370-E-AC • SPR-X22-360-E-AC • SPR-X21-350-BLK-E-AC • SPR-X21-335-BLK-E-AC • SPR-X20-327-BLK-E-AC • SPR-X21-345-E-AC • SPR-X21-335-E-AC • SPR-X20-327-E-AC • SPR-E20-327-E-AC • SPR-E19-320-E-AC

With Universal InvisiMount:

Manufacturer	Module Model / Series
SunPower	<ul style="list-style-type: none"> • SPR-Axxx-COM (may be followed by -BLK), where xxx can be 380–460. • SPR-Axxx-yyy-MLSD, where xxx can be 350–460 and where yyy can be -COM and/or -300 V.
Aptos	<ul style="list-style-type: none"> • DNA-120-MF26-xxxW, where xxx is wattage. • DNA-108-BF10-xxxW, where xxx is wattage. • DNA-120-BF26-xxxW where xxx is 350–370.
Hanwha	<ul style="list-style-type: none"> • Q.PEAK DUO BLK ML-G10.a+ xxx, where xxx can be 370–425.

REC	<ul style="list-style-type: none"> • RECxxxNP2, where xxx can be 350–380. • RECxxxNP2 Black, where xxx can be 350–380. • RECxxxTP4, where xxx can be 350–380. • RECxxxTP4 Black, where xxx can be 350–380. • RECxxxAA, where xxx can be 340–385. • RECxxxAA Black, where xxx can be 340–385. • RECxxxAA Pure, where xxx can be 380–415.
Trina	<ul style="list-style-type: none"> • TSM-xxxDE06X.05(II), where xxx can be 355–380.
Jinko	<ul style="list-style-type: none"> • JKMxxxM-6RL3-B, where xxx can be 365–400.
Canadian Solar	<ul style="list-style-type: none"> • Canadian Solar: CS3NxxxMS where xxx is 380–405.
Waaree	<ul style="list-style-type: none"> • WSMDi-xxx where xxx is 395–415.

System Design Load Rating: 10 PSF downward, 5 PSF upward, 5 PSF lateral. Actual system structural capacity is defined by the *InvisiMount Span Tables 524734*.

Grounding from the module to the rail is accomplished through the clamps. See Section 1.5 for more information. The Listing also includes the following components, which have been evaluated for both mounting and bonding in accordance with UL 2703:

- End clamp
- Mid clamp
- Rail
- Splice and splice screw
- Ground lug assembly
- L-foot
- Row-to-row (R2R) grounding clip
- Row-to-row (R2R) grounding jumper
- Row-to-row (R2R) spacer
- Rail-mounted grounding junction box (RMJ)

SunPower Classic InvisiMount™ Ground Path and Compliance

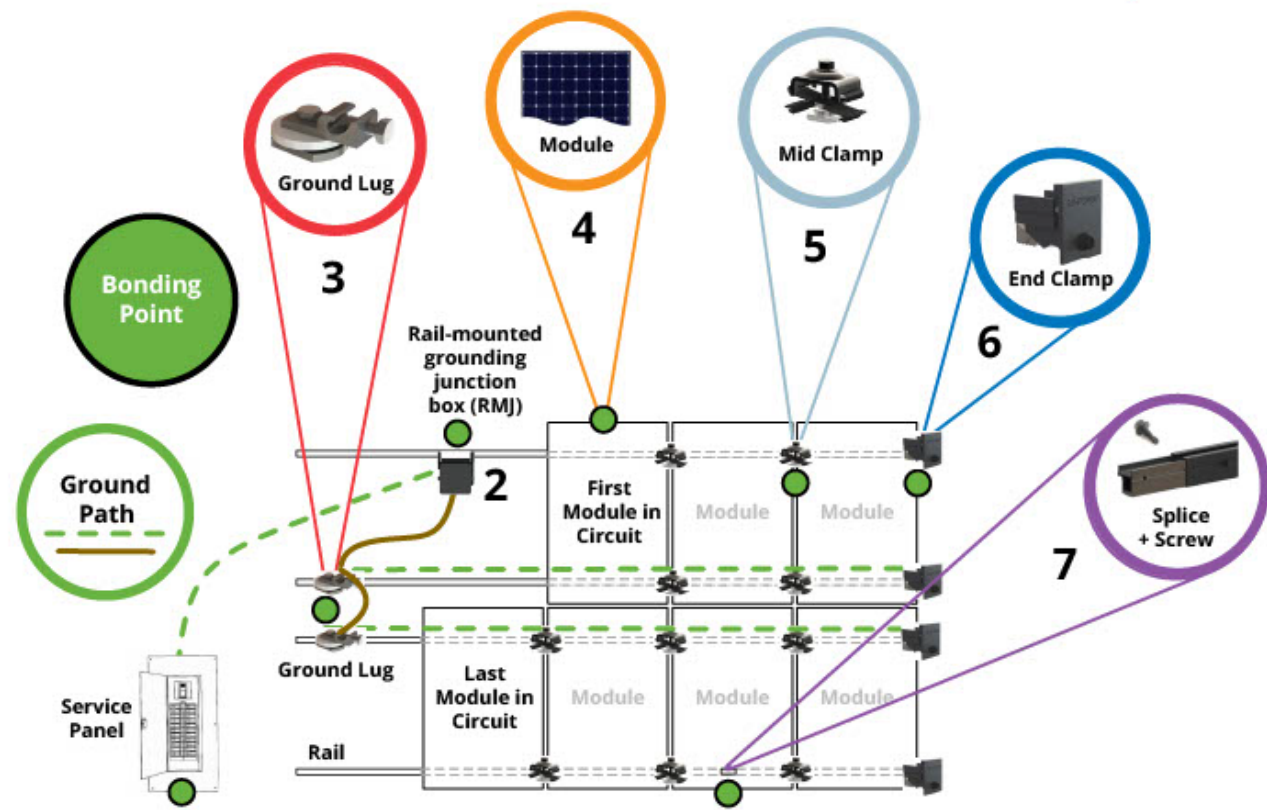

	Bonding Components	Compliance	
		NEC	UL
1	Grounding Electrode to Service Panel	690.47(A) 690.47(D)	n/a
2	Service Panel to Ground Wire	690.43(C)	1741
3	Ground Wire to Ground Lug to Rail	690.43(C)	2703
4	Module Frame	n/a	1703
5	Rail to Mid Clamp to Module Frame	690.43(A) 690.43(C) 690.43(D)	2703
6	Module Frame to End Clamp to Rail	690.43(A) 690.43(C) 690.43(D)	2703
7	Rail to Splice	690.43(A) 690.43(C) 690.43(D)	2703

SunPower Classic InvisiMount™ with R2R Grounding Clip Ground Path and Compliance

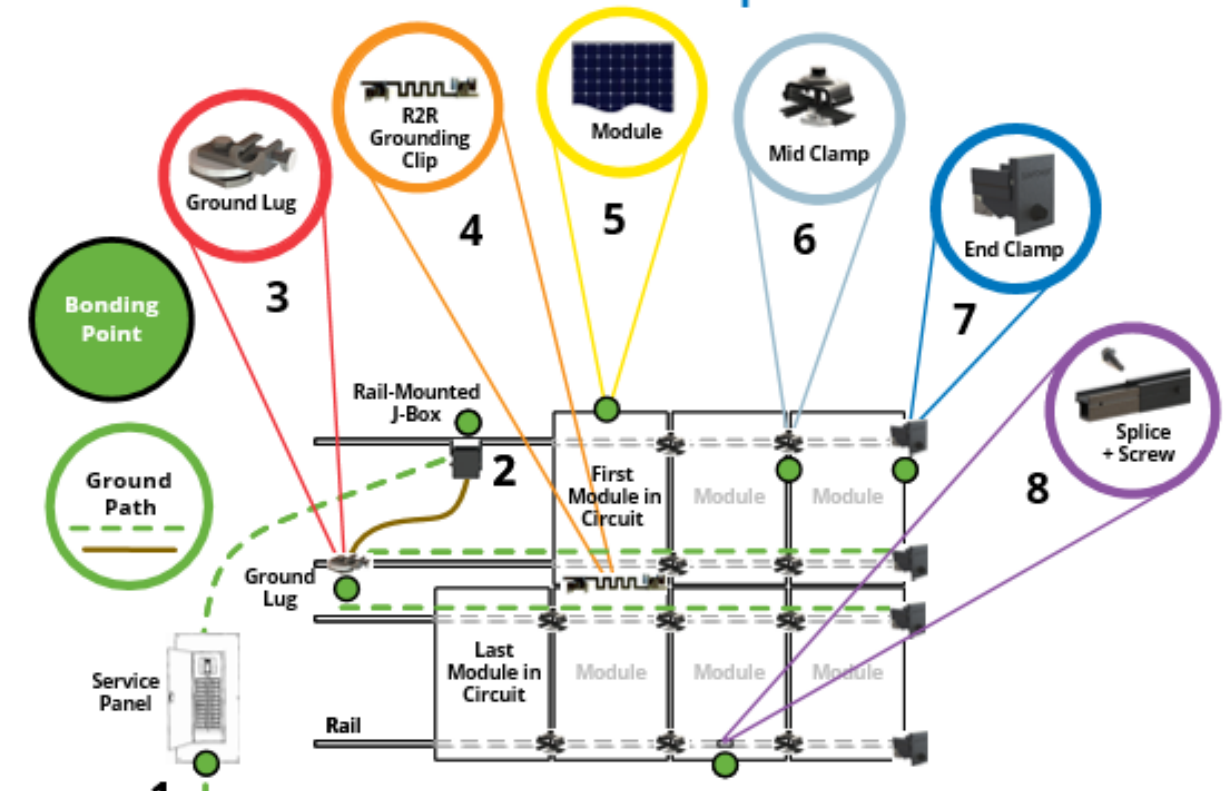

	Bonding Components	Compliance	
		NEC	UL
1	Grounding Electrode to Service Panel	690.47(A) 690.47(D)	n/a
2	Service Panel to Ground Wire	690.43(C)	1741
3	Ground Wire to Ground Lug to Rail	690.43(C)	2703
4	Module Frame to Module Frame	690.43(C)	2703
5	Module Frame	n/a	1703
6	Rail to Mid Clamp to Module Frame	690.43(A) 690.43(C) 690.43(D)	2703
7	Module Frame to End Clamp to Rail	690.43(A) 690.43(C) 690.43(D)	2703
8	Rail to Splice	690.43(A) 690.43(C) 690.43(D)	2703

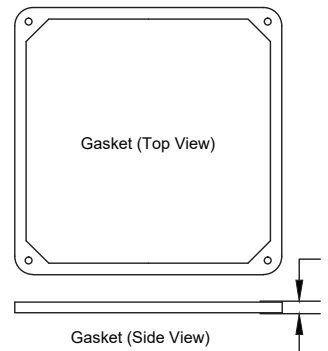
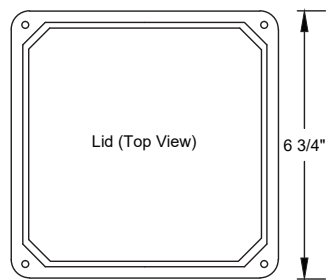
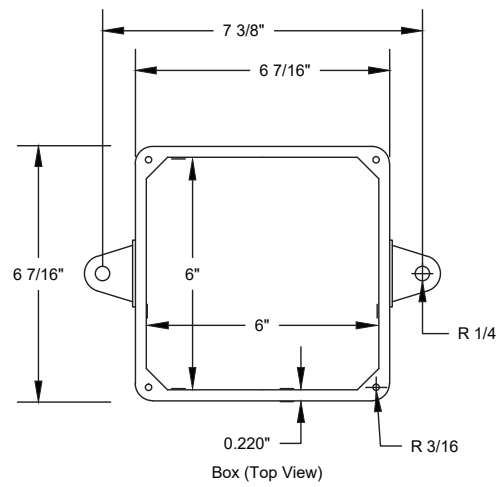
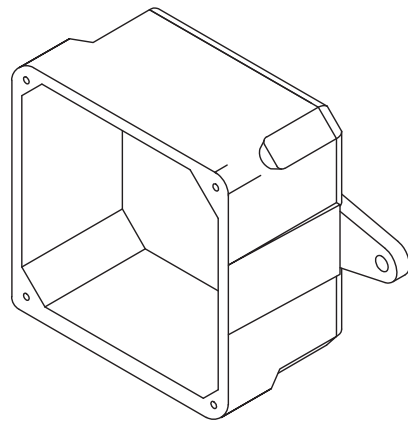
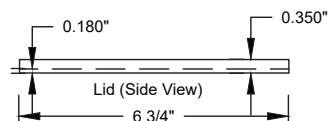
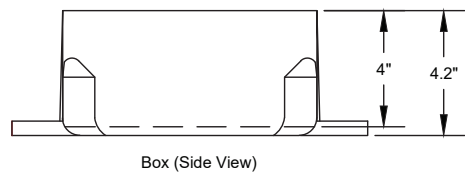

UL Listed
 Marine Listed
 UL File # E205935 (QCUP)
 UL Control # 92CM
 Material is Rigid PVC
 132 cu in Volume (2163 cu cm)
 Screws are Zinc Plated Steel
 Gasket is neoprene

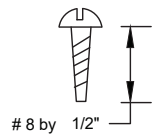

CANTEX INC. Fort Worth, TEXAS		
Junction Box 6 x 6 x 4		
Drawn By: O.M.	Date: 6/19/17	5133710

July 29, 2022

To whom it may concern,

This letter confirms and attests that:

SPWR-A5 is equivalent to Enphase Models:

IQ7HS-66-ACM-US, 369 VA, 208Vac Grid Support Utility Interactive Inverter
IQ7HS-66-E-ACM-US, 369 VA, 208Vac Grid Support Utility Interactive Inverter
IQ7HS-66-M-US, 369 VA, 208Vac Grid Support Utility Interactive Inverter
IQ7HS-66-ACM-US, 384 VA, 240Vac Grid Support Utility Interactive Inverter
IQ7HS-66-E-ACM-US, 384 VA, 240Vac Grid Support Utility Interactive Inverter
IQ7HS-66-M-US, 384 VA, 240Vac Grid Support Utility Interactive Inverter

Regards,



Aranjit Sangha
Senior Staff Engineer
Enphase Energy Inc.
1420 North McDowell Blvd.
Petaluma, CA 94954
v: (707) 763-4784 x7098
asangha@enphaseenergy.com

TYPE IPC



Features

- Body is molded from tough, resilient glass-filled nylon
 - Compact design
 - Tin plated copper contact teeth
 - Insulation piercing
 - Perforated end tabs
 - Pre-filled with silicone lubricant
 - Versatile
 - Increased safety
- Horizontal line grid
 - Temperature rating 90° C

Benefits

- Provides high degree of breakage resistance and long dependable use
- Saves space
- Easily penetrates most types of insulation
- No need to strip the conductor which saves installation time
- Break out easily by hand
- Prevents oxidation and moisture from entering the contact area
- Can be used as a splice or tap connector
- Contains no external energized parts. Can be installed "hot" on energized conductors providing tap conductor is not under load.
- Provides a visual guide for proper installation of conductors

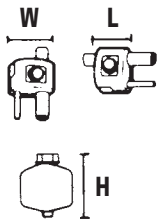

Fig. 1



Fig. 2



Fig. 3



Fig. 4

Catalog Number	Figure Number	Wire Range		Volts	Current Rating		Dimensions			Torque Ft. Lbs.	Bolt Head Size
		Main	Tap		CU	AL	L	W	H		
IPC-1/0-2	3	1/0-8	2-8	300 (480 Grounded Y System)	130	100	1-7/32	1-15/32	2-5/16	16	1/2
IPC-4/0-6	2	4/0-4	6-14	600	75	60	1-27/64	1	1-7/8	13	1/2
IPC-4/0-2/0	3	4/0-2	2/0-6	600	195	150	1-21/32	1-7/8	2-7/8	25	1/2
IPC-250-4/0	2	250kcmil-1	4/0-6	600	260	205	1-7/8	2-11/32	3-11/32	30	5/8
IPC-350-4/0	3	350kcmil-4/0	4/0-10	300 (480 Grounded Y System)	260	205	1-43/64	2-7/16	3-1/8	25	5/8
IPC-350-350	4	350kcmil-4/0	350kcmil-4/0	300 (480 Grounded Y System)	350	280	2-43/64	2-23/32	3-1/4	25	5/8
IPC-500-12	1	500kcmil-250kcmil	10-12	300 (480 Grounded Y System)	40	35	1-43/64	2-7/16	3-1/4	25	5/8
IPC-500-250	1	500kcmil-250kcmil	250kcmil-4	600	290	230	2-27/64	2-29/32	3-3/4	55	5/8-11/16
IPC-500-500	1	500kcmil-300kcmil	500kcmil-250kcmil	600	430	350	3-3/16	3-5/8	5	75	7/8-7/8
IPC-750-500	1	750kcmil-500kcmil	500kcmil-350kcmil	600	430	350	3-3/16	3-5/8	5	75	7/8-7/8

All wire sizes, unless noted otherwise, are American Wire Gauge (AWG)
Tested to UL 486A/B, UL File E6207

E