

# RESIDENTIAL ROOFTOP SOLAR PERMIT PACKAGE



**Laura Gallatin**  
 55 Walburn Wy  
 Lillington, North Carolina 27546  
 8144493818



1403 N 630 E  
 Orem, Utah 84097  
 (800) 377-4480  
 BlueRavenSolar.com

**SCOPE OF WORK**  
 INSTALLATION OF ROOFTOP MOUNTED PHOTOVOLTAIC SOLAR SYSTEM



**SHEET INDEX**

- PV1 COVER SHEET
- PV2 SITE PLAN
- PV3 ROOF PLAN
- PV4 STRUCTURAL
- PV5 ELECTRICAL 3-LINE
- PV6 ELECTRICAL CALCULATIONS
- PV7 LABELS
- PV8 PLACARD
- SS SPEC SHEETS

**CUSTOMER NAME:** Laura Gallatin  
 55 Walburn Wy  
 Lillington, North Carolina 27546

**AHJ:** Harnett County

**UTILITY COMPANY:** Duke Energy NC

**TYPICAL STRUCTURAL INFORMATION**

ROOF MATERIAL: Comp Shingle  
 SHEATHING: OSB  
 FRAMING: Manufactured Truss  
 RACKING: UNIRAC SFM INFINITY  
 ROOF ATTACHMENT: UNIRAC SFM INFINITY FLASHKIT  
 TOTAL ATTACHMENTS: 23

**NEW PV SYSTEM INFORMATION**

DC SYSTEM SIZE: 7.98 kW DC  
 AC SYSTEM SIZE: 6.175 kW AC  
 MODULE TYPE: (19) Silfab Solar SIL-420 QD  
 INVERTER TYPE: (19) Enphase IQ8M-72-M-US

**TOTAL PV DC SYSTEM SIZE**  
 7.980 kW DC

**TOTAL PV AC SYSTEM SIZE**  
 6.175 kW AC

**DESIGN CRITERIA**

WIND SPEED: 115  
 WIND EXPOSURE FACTOR: C  
 RISK CATEGORY: II  
 GROUND SNOW LOAD: 15  
 ROOF SNOW LOAD: 10.5  
 SEISMIC DESIGN CATEGORY: B

**WEATHER STATION DATA**

WEATHER STATION: SEYMOUR-JOHNSON AFB  
 HIGH TEMP 2% AVG: 35°C  
 EXTREME MINIMUM TEMP: -10°C

**APPLICABLE CODES**

\*2017 NATIONAL ELECTRIC CODE (NEC)  
 \*2018 NORTH CAROLINA BUILDING CODE (NCBC)  
 \*2018 NORTH CAROLINA RESIDENTIAL CODE (NCRC), PLUMBING CODE (NCPC), AND ALL STATE AND LOCAL BUILDING, ELECTRICAL, AND PLUMBING CODES

**GENERAL NOTES**

Sealed For Existing Roof & Attachment Only

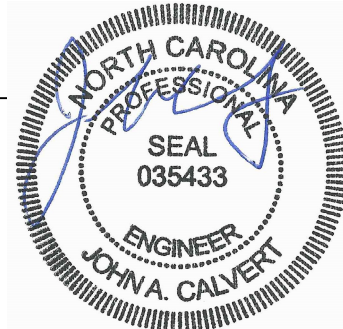

6/17/24  
 Firm No.: D-0449

**AHJ**  
 Harnett County

**UTILITY COMPANY**  
 Duke Energy NC

**PROJECT ID:**  
 988694

**PV DC SYSTEM SIZE:**  
 7.980 kW DC

**PV AC SYSTEM SIZE:**  
 6.175 kW AC

**REVISIONS:**

A	----
B	----
C	----
D	----

**DRAWN BY:**  
 Brendan Fillmore

**PLOT DATE:**  
 June 15, 2024

**DRAWING TITLE:**  
 Cover Sheet

**DRAWING NUMBER:**  
 PV1

# FRONT OF HOME

55 Walburn Wy

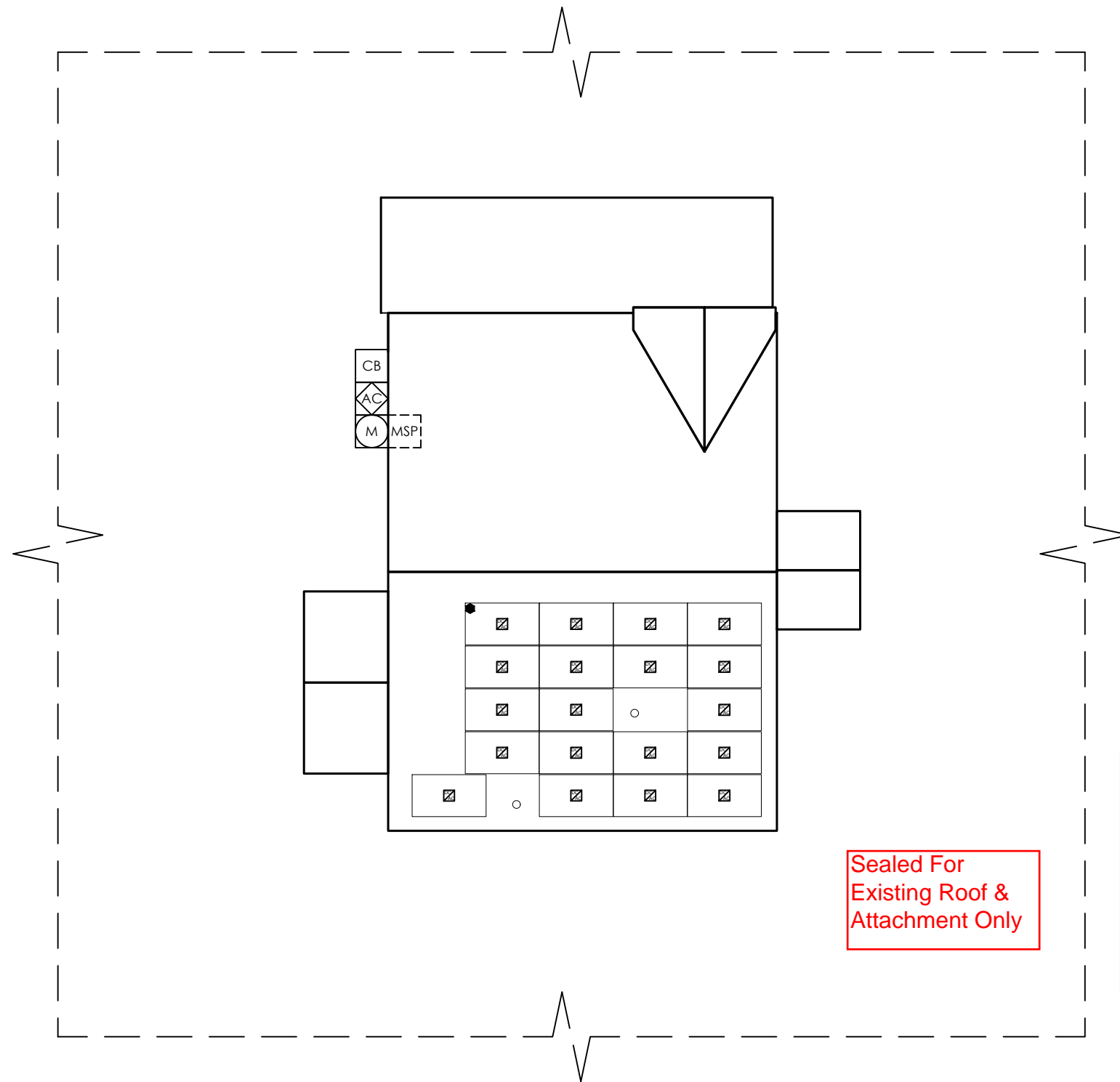

Sealed For Existing Roof & Attachment Only

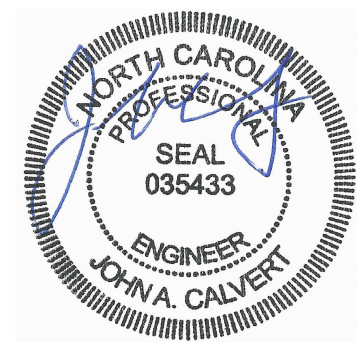

6/17/24  
Firm No. : D-0449



1403 N 630 E  
Orem, Utah 84097  
(800) 377-4480  
BlueRavenSolar.com

**CUSTOMER NAME:** Laura Gallatin  
55 Walburn Wy  
Lillington, North Carolina 27546

**AHJ:** Harnett County

**UTILITY COMPANY:** Duke Energy NC

**PROJECT ID:** 988694

**PV DC SYSTEM SIZE:** 7.980 kW DC

**PV AC SYSTEM SIZE:** 6.175 kW AC

**REVISIONS:**

A	----
B	----
C	----
D	----

**DRAWN BY:** Brendan Fillmore

**PLOT DATE:** June 15, 2024

**DRAWING TITLE:** Site Plan

**DRAWING NUMBER:** PV2

**SITE PLAN**  
SCALE: 3/32" = 1'-0"

### LEGEND

UTILITY METER	BREAKER ENCLOSURE	ESS - BATTERY	FIRE SETBACK HATCH	TRENCH OR OVERHEAD
MAIN SERVICE PANEL	AC DISCONNECT	ESS - CONTROLLER	MICROINVERTER	PROPERTY LINE
SUBPANEL	PV PRODUCTION METER	REMOTE POWER OFF SWITCH	ROOF TOP JUNCTION BOX	<b>ICONS WITH DOTTED OUTLINE INDICATE INTERIOR LOCATION</b>
UTILITY METER CT CABINET	COMBINER BOX	GENERATOR ATS PANEL	INVERTER	

### PV SYSTEM SPECIFICATIONS

#### NEW PV SYSTEM INFORMATION

**PV MODULE:** (19) Silfab Solar SIL-420 QD, **POWER RATING:** 420 W  
**INVERTER:** (19) Enphase IQ8M-72-M-US, **POWER RATING:** 325 W

### COMPASS

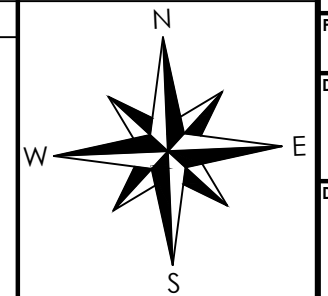

DC SYSTEM SIZE: 7.98 KW DC MODULE: Silfab Solar 420 INVERTER(S): Enphase IQ8M Microinverters



1403 N 630 E  
Orem, Utah 84097  
(800) 377-4480  
BlueRavenSolar.com

# FRONT OF HOME

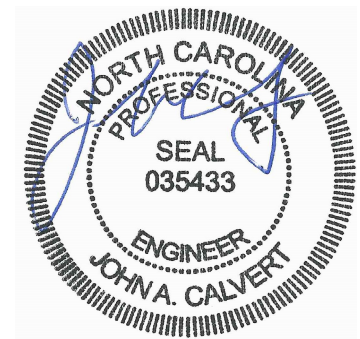
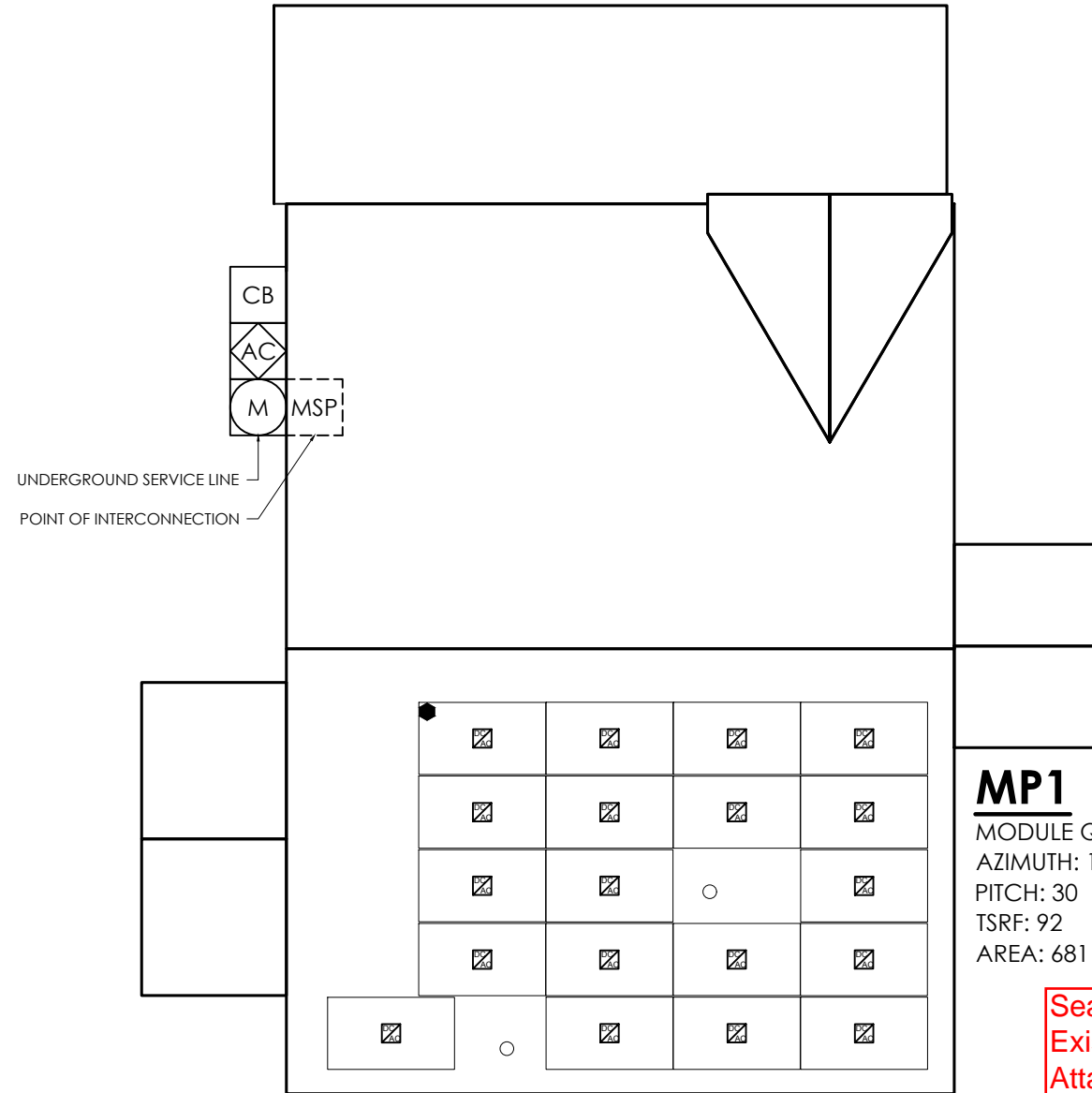

6/17/24  
Firm No. : D-0449

## ROOF PLAN

SCALE: 1/8" = 1'-0"

### LEGEND

UTILITY METER	BREAKER ENCLOSURE	ESS - BATTERY	FIRE SETBACK HATCH	TRENCH OR OVERHEAD
MAIN SERVICE PANEL	AC DISCONNECT	ESS - CONTROLLER	MICROINVERTER	PROPERTY LINE
SUBPANEL	PV PRODUCTION METER	REMOTE POWER OFF SWITCH	ROOF TOP JUNCTION BOX	<b>ICONS WITH DOTTED OUTLINE INDICATE INTERIOR LOCATION</b>
UTILITY METER CT CABINET	COMBINER BOX	GENERATOR ATS PANEL	INVERTER	

### PV SYSTEM SPECIFICATIONS

**NEW PV SYSTEM INFORMATION**  
**PV MODULE:** (19) Silfab Solar SIL-420 QD, **POWER RATING:** 420 W  
**INVERTER:** (19) Enphase IQ8M-72-M-US, **POWER RATING:** 325 W

### COMPASS

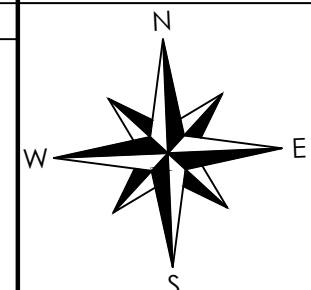

CUSTOMER NAME:

PROJECT ID:

**988694**

PV DC SYSTEM SIZE:  
7.980 kW DC

PV AC SYSTEM SIZE:  
6.175 kW AC

REVISIONS:

	----
	----
	----
	----

DRAWN BY:  
Brendan Fillmore

PLOT DATE:  
June 15, 2024

DRAWING TITLE:  
Roof Plan

DRAWING NUMBER:  
**PV3**

**Laura Gallatin**  
55 Walburn Wy  
Lillington, North Carolina 27546

AHJ: Harnett County  
UTILITY COMPANY: Duke Energy NC

PANEL COUNT	AZIMUTH (DEG)	PITCH (DEG)	TSRF (%)	AREA (ft²)	ROOF MATERIAL	SHEATHING TYPE	FRAMING TYPE	FRAMING SIZE AND SPACING	CEILING JOIST/PURLINS SIZE AND SPACING	RACKING TYPE	ATTACHMENT TYPE	MAXIMUM ATTACHMENT SPACING (S)	MAXIMUM CANTILEVER (C)	
MP1	19	182	30	92	681	Comp Shingle	OSB	Manufactured Truss	2x4 @ 24 in OC	2x4 @ 24 in OC	UNIRAC SFM INFINITY	UNIRAC SFM INFINITY FLASHKIT	72"L / 48"P	24"L / 16"P
MP2	0													
MP3	0													
MP4	0													
MP5	0													
MP6	0													
MP7	0													
MP8	0													
MP9	0													
MP10	0													

TOTAL PV ARRAY AREA (ft²)	398.98
TOTAL ROOF AREA (ft²)	1840
DISTRIBUTED LOAD (psf)	2.2
ROOF COVERAGE (%)	21.68
TOTAL PV ARRAY WEIGHT (lbs)	879.7
TOTAL PV ATTACHMENTS	23
POINT LOAD (lbs/att.)	38.2



1403 N 630 E  
Orem, Utah 84097  
(800) 377-4480  
BlueRavenSolar.com

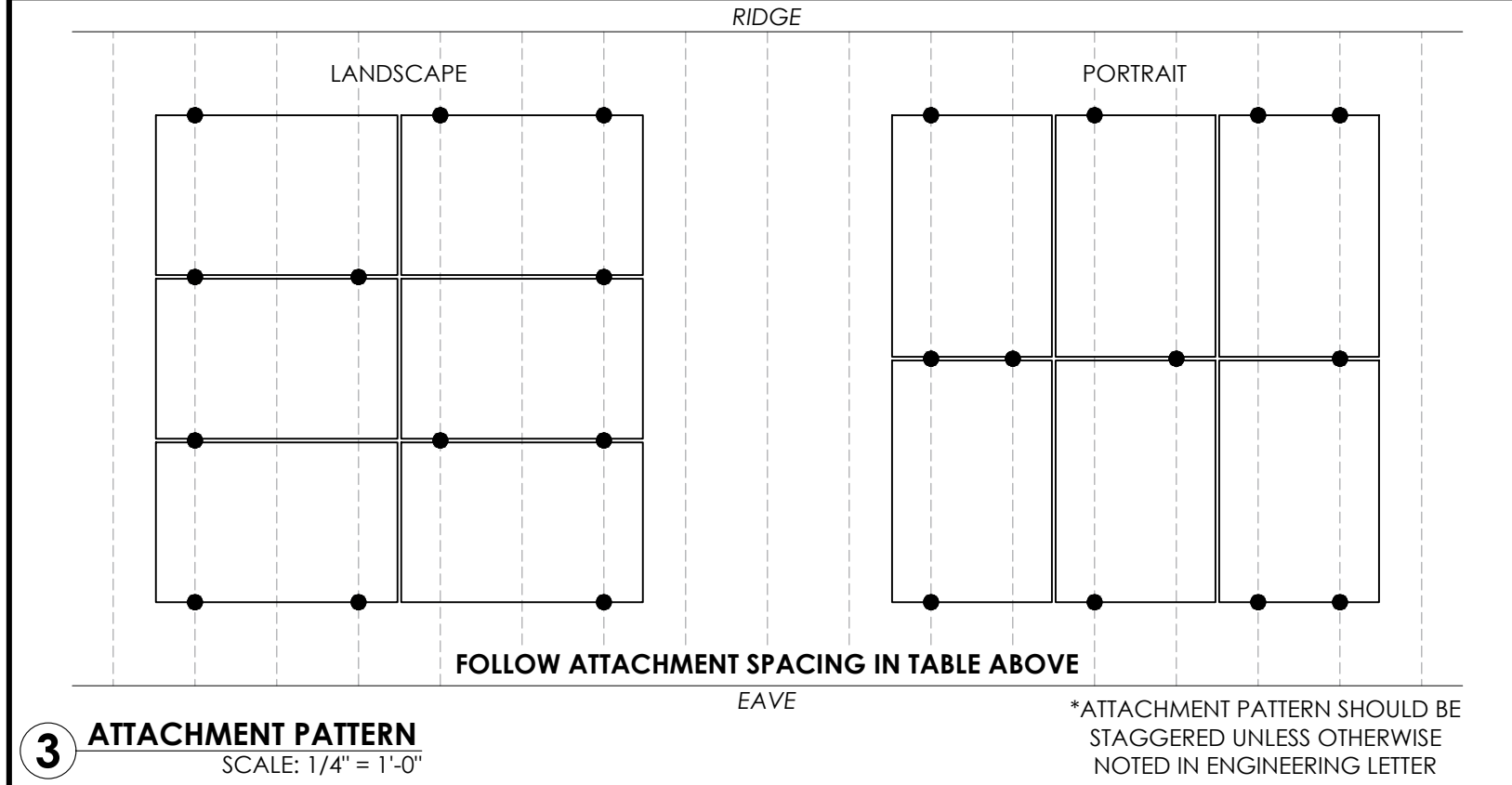
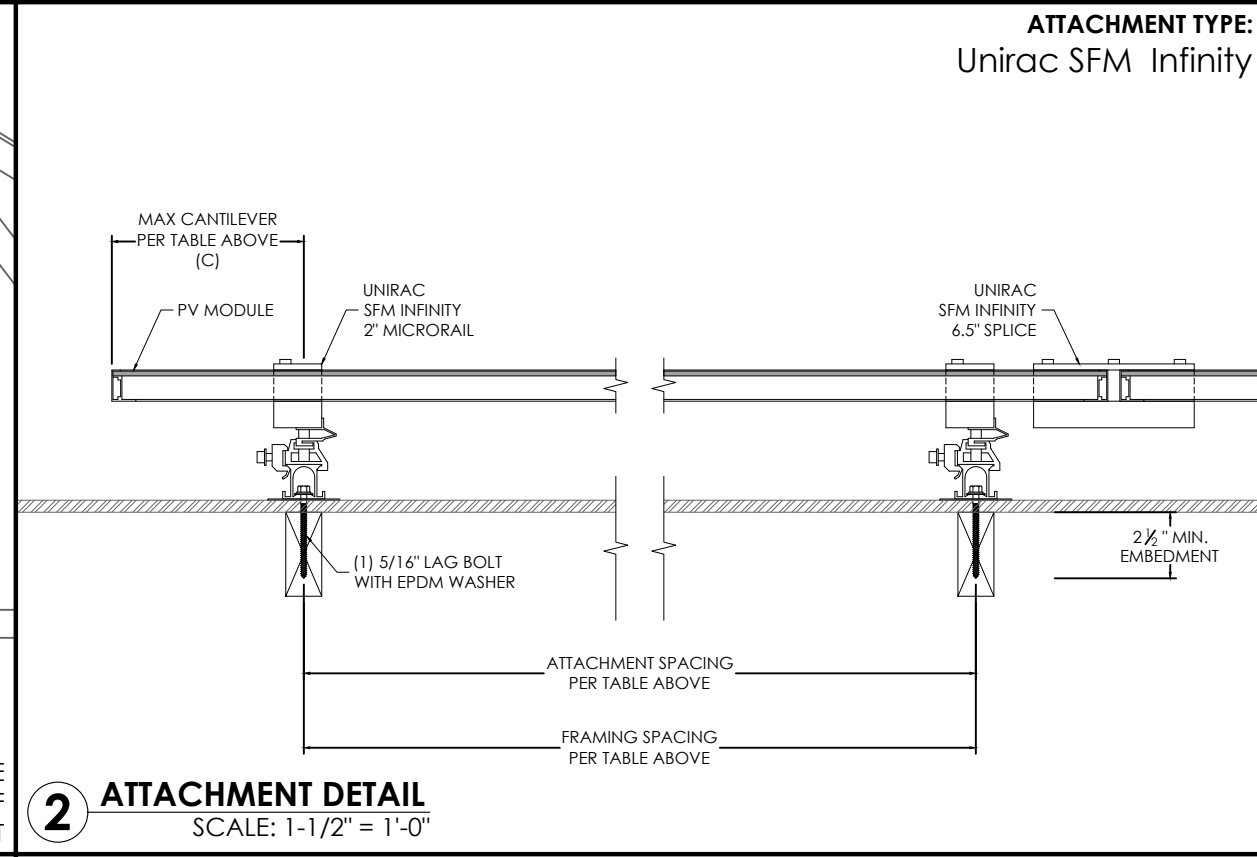
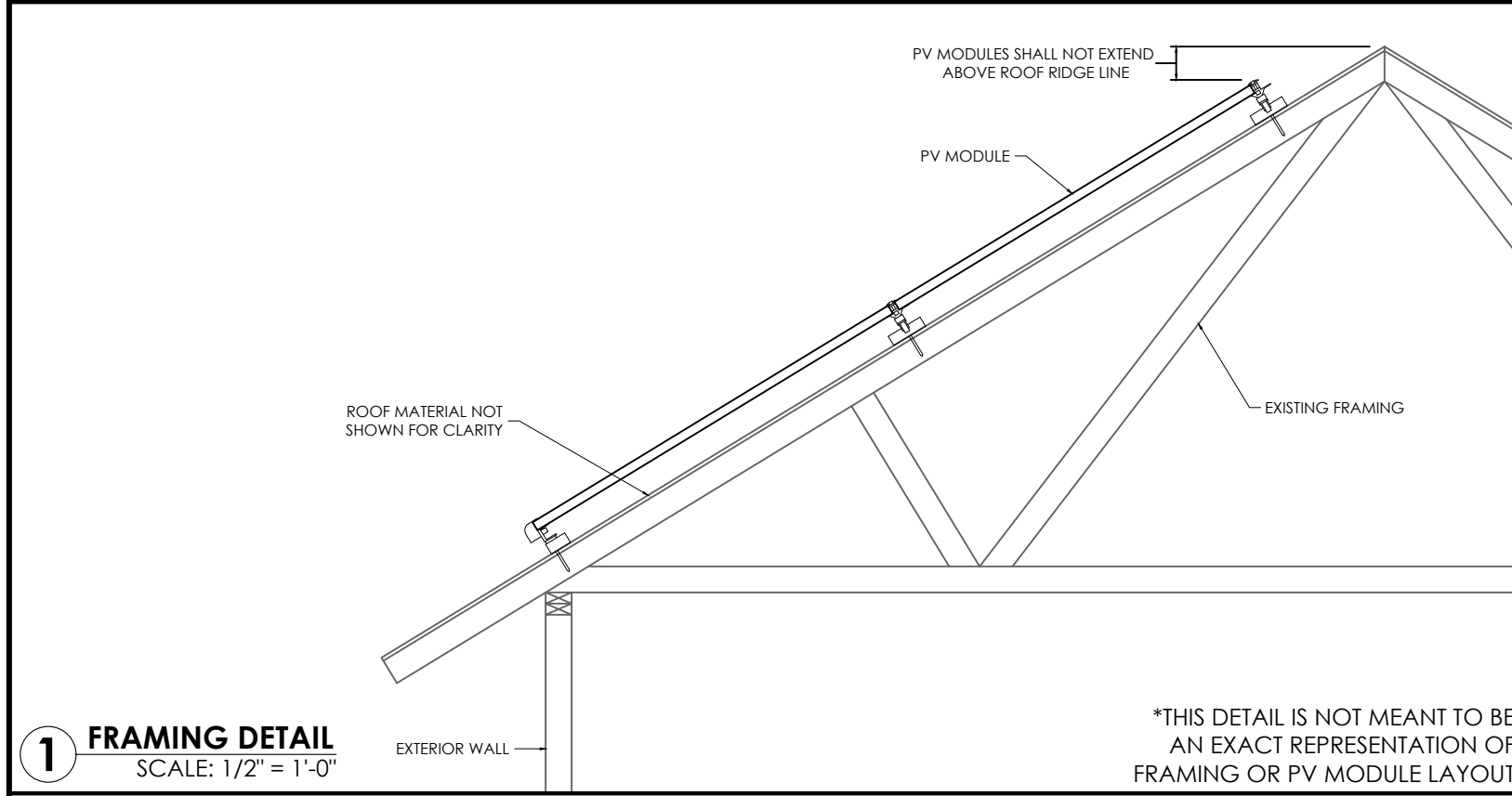

NOTES

Sealed For Existing Roof & Attachment Only

6/17/24  
Firm No. : D-0449

CUSTOMER NAME: **Laura Gallatin**  
55 Walburn Wy  
Lillington, North Carolina 27546

AHJ: Harnett County  
UTILITY COMPANY: Duke Energy NC

PROJECT ID: **988694**

PV DC SYSTEM SIZE: 7.980 kW DC

PV AC SYSTEM SIZE: 6.175 kW AC

REVISIONS:

A	---
B	---
C	---
D	---

DRAWN BY: Brendan Fillmore

PLOT DATE: June 15, 2024

DRAWING TITLE: Structural

DRAWING NUMBER: **PV4**

<b>4</b>	L1 (1) 8 AWG THHN/THWN-2 CU BLACK	3/4 INCH EMT	Exterior
	L2 (1) 8 AWG THHN/THWN-2 CU RED		
	N (1) 8 AWG THHN/THWN-2 CU WHITE		
	G (1) 10 AWG THHN/THWN-2 CU GREEN		

<b>3</b>	L1 (2) 10 AWG THHN/THWN-2 CU BLACK	3/4 INCH EMT	Exterior	
	L2 (2) 10 AWG THHN/THWN-2 CU RED			
	G (1) 10 AWG THHN/THWN-2 CU GREEN			
	*TYPE UF CABLE MAY BE SUBSTITUTED FOR USE IN CONDUIT WHERE NEC CODE PERMITS			

<b>2</b>	L1 (1) 10 AWG THHN/THWN-2 CU BLACK	3/4 INCH	*	
	L2 (1) 10 AWG THHN/THWN-2 CU RED			
	G (1) 10 AWG THHN/THWN-2 CU GREEN			
	*TYPE NM (ROMEX)/UF CABLE IS PERMITTED FOR INTERIOR OR ATTIC RUNS AND SHALL BE USED WHEN NEC CODE PERMITS			

<b>1</b>	L1 (1) 12 AWG THHN/THWN-2 CU BLACK	ENPHASE Q-CABLE, 2-WIRE, FREE AIR	Exterior	
	L2 (1) 12 AWG THHN/THWN-2 CU RED			
	G (1) 6 AWG BARE, CU			



1403 N 630 E  
Orem, Utah 84097  
(800) 377-4480  
BlueRavenSolar.com

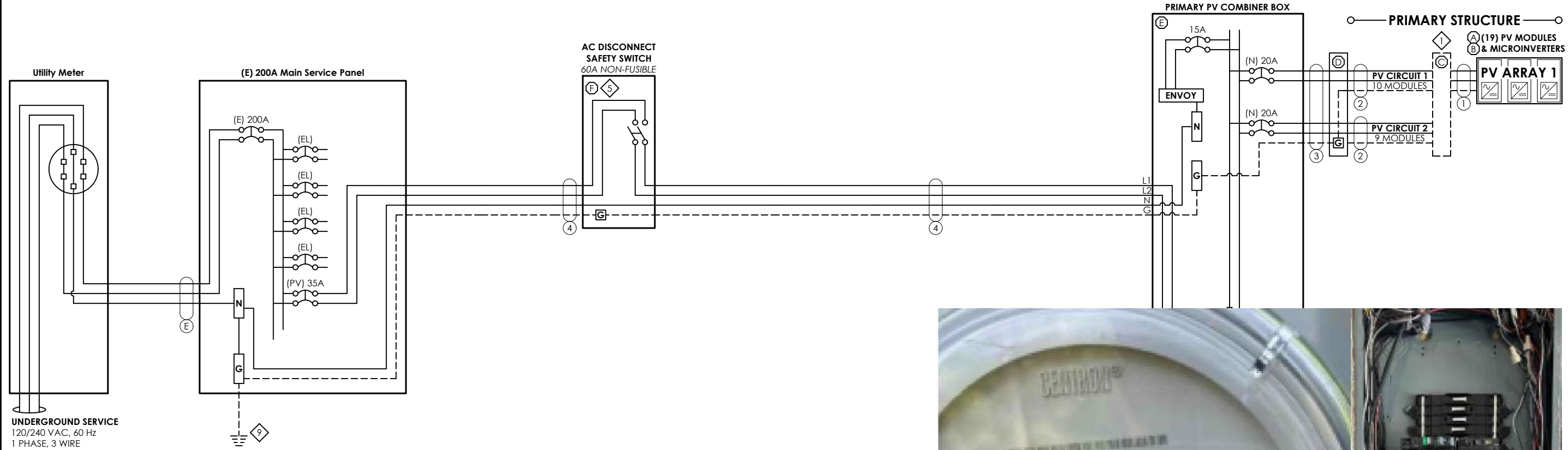

**GENERAL NOTES**

Utility Meter Number: 348789466  
Load side breaker in MSP. Interior POI.

LEGEND	
(E) EXISTING	(PV) PV BREAKER
(N) NEW	(FIB) FACTORY INSTALLED BREAKER
(EL) EXISTING LOADS	SPD SURGE PROTECTIVE DEVICE
(RL) RELOCATED LOADS	MI MECHANICAL INTERLOCK

**EQUIPMENT NOTES**

1 FINAL CONFIGURATION OF PV CIRCUITS TO BE DECIDED BY INSTALLER. MUST COMPLY WITH MAX MICROINVERTERS PER CIRCUIT AS LISTED ON ATTACHED SPEC SHEET.

2

3

4

5

6

7

8

9 GROUNDING ELECTRODE SYSTEM SHALL BE IN ACCORDANCE WITH NEC 250.53.

10

11

12

EQUIPMENT DESCRIPTIONS	
(A) PV MODULE: Silfab Solar SIL-420 QD, 420 W DC, UL 1703 / UL 61730 COMPLIANT	
(B) MICROINVERTER: ENPHASE IQ8M-72-M-US, 325 W AC (0.325 kW), 1 PHASE, UL 1741 COMPLIANT	
(C) ROOFTOP JUNCTION BOX: EZ SOLAR JB-1.2 JUNCTION BOX	
(D) JUNCTION BOX: PVC 4 X 4 JUNCTION BOX	
(E) PV COMBINER BOX: ENPHASE COMBINER 4 (X2-IQ-AM1-240-4)	
(F) SQUARE-D SAFETY SWITCH 60A, 2P, 240VAC, NON-FUSIBLE (DU222RB)	
(G)	
(H)	
(I)	
(J)	
(K)	
(L)	
(M)	
(N)	
(O)	
(P)	
(Q)	
(R)	
(S)	
(T)	

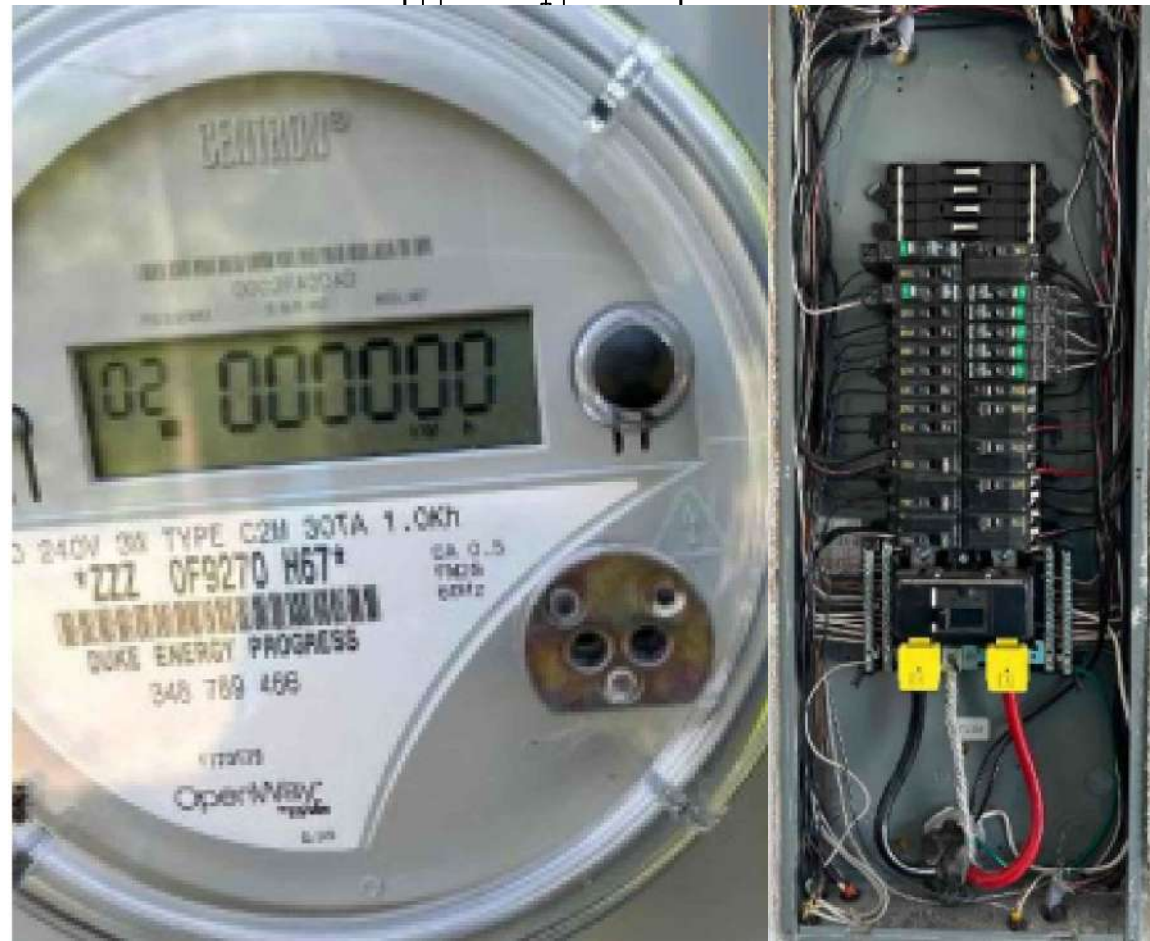

**OTHER NOTES**

19 MICROINVERTERS X 325 W AC = 6.175 KW AC; PANEL WATTAGE = 420 W DC

**CUSTOMER NAME:** Laura Gallatin  
55 Walburn Wy  
Lillington, North Carolina 27546

**AHJ:** Harnett County  
Duke Energy NC

**PROJECT ID:** 988694

**PV DC SYSTEM SIZE:** 7.980 kW DC

**PV AC SYSTEM SIZE:** 6.175 kW AC

**REVISIONS:**

(A)	----
(B)	----
(C)	----
(D)	----

**DRAWN BY:** Brendan Fillmore

**PLOT DATE:** June 15, 2024

**DRAWING TITLE:** Electrical 3-Line

**DRAWING NUMBER:** PV5

ELECTRICAL INFORMATION	
<b>UTILITY ELECTRICAL SYSTEM</b>	
1-Phase, 3-Wire, 60Hz, 120/240V	
<b>NEW PV SYSTEM</b>	
1-Phase, 3-Wire, 60Hz, 120/240V	
AC SYSTEM SIZE	6.175kW AC
DC SYSTEM SIZE	7.98kW DC
<b>PV MODULES</b>	
QUANTITY	19
TYPE	Silfab Solar SIL-420 QD
WATTAGE	420W DC
<b>MICROINVERTERS</b>	
TYPE	Enphase IQ8M-72-M-US
OUTPUT CURRENT	1.35A AC
NOMINAL VOLTAGE	240V AC
OUTPUT POWER	325W AC

PV BREAKER BACKFEED CALCULATIONS			
NEC 705.12(B) -- "120% RULE"			
(BUSBAR RATING * 120%) - OCPD RATING = AVAILABLE BACKFEED			
	MAIN SERVICE PANEL	SUBPANEL 1	SUBPANEL 2
BUSBAR RATING	200A	---A	---A
PANEL OCPD RATING	200A	---A	---A
AVAILABLE BACKFEED (120% RULE)	40A	##A	##A
PV BREAKER RATING	35A	35A	35A
<b>*THESE CALCULATIONS ARE ONLY APPLICABLE IF PV INTERCONNECTION IS A LOAD SIDE BREAKER. *PV BREAKER MUST BE RATED LESS THAN OR EQUAL TO AVAILABLE BACKFEED FOR CODE COMPLIANCE*</b>			

DESIGN LOCATION AND TEMPERATURES	
DATA SOURCE	ASHRAE Weather Station Data
STATE	North Carolina
CITY	Lillington
WEATHER STATION	SEYMOUR-JOHNSON AFB
HIGH TEMP 2% AVG	35°C
EXTREME MINIMUM TEMP	-10°C

WIRE SIZE SPECIFICATIONS										
	①	②	③	④	⑤	⑥	⑦	⑧	⑨	⑩
MINIMUM CONDUCTOR AMPACITY	16.88A AC	16.88A AC	16.88A AC	32.16A AC	---A AC	---A AC	---A AC	---A AC	---A AC	---A AC
CONDUCTOR MATERIAL	CU	CU	CU	CU	---	---	---	---	---	---
CONDUCTOR TYPE	THHN/THWN-2	THHN/THWN-2	THHN/THWN-2	THHN/THWN-2	---	---	---	---	---	---
CONDUCTOR SIZE	12 AWG	10 AWG	10 AWG	8 AWG	---	---	---	---	---	---
CONDUCTOR AMPACITY	30A	40A	40A	55A	---A	---A	---A	---A	---A	---A
AMBIENT TEMPERATURE ADJUSTMENT FACTOR	0.96	0.96	0.96	0.96	---	---	---	---	---	---
CONDUIT FILL ADJUSTMENT FACTOR	1	1	0.8	1	---	---	---	---	---	---
ADJUSTED CONDUCTOR AMPACITY	28.8A	38.4A	30.72A	52.8A	---A	---A	---A	---A	---A	---A
WIRE RUN DISTANCE (FT)	66	40	20	10	---	---	---	---	---	---
CALCULATED VOLTAGE DROP	0.8%	0.56%	0.28%	0.17%	0%	0%	0%	0%	0%	0%

PV CIRCUIT SPECIFICATIONS													
	PRIMARY STRUCTURE								DETACHED STRUCTURE				
	CIRCUIT 1	CIRCUIT 2	CIRCUIT 3	CIRCUIT 4	CIRCUIT 5	CIRCUIT 6	CIRCUIT 7	CIRCUIT 8	CIRCUIT 1	CIRCUIT 2	CIRCUIT 3	CIRCUIT 4	CIRCUIT 5
NUMBER OF MODULES PER CIRCUIT	10	9	0	0	0	0	0	0	0	0	0	0	0
RATED AC OUTPUT CURRENT (I <sub>out</sub> )	13.5A	12.2A	0.0A	0.0A	0.0A	0.0A	0.0A	0.0A	0.0A	0.0A	0.0A	0.0A	0.0A
MINIMUM AMPACITY (I <sub>out</sub> x 125%)	16.9A	15.2A	0.0A	0.0A	0.0A	0.0A	0.0A	0.0A	0.0A	0.0A	0.0A	0.0A	0.0A
OVERCURRENT PROTECTION RATING	20A	20A	20A	20A	20A	20A	20A	20A	20A	20A	20A	20A	20A
COMBINED AC OUTPUT CURRENT (C <sub>out</sub> )	25.7A								0.0A				
MINIMUM AMPACITY (C <sub>out</sub> x 125%)	32.1A								0.0A				
COMBINED PV BREAKER RATING	35AA								0AA				

TOTAL VOLTAGE DROP	
WIRE TAG #	VOLTAGE DROP
WIRE TAG #1	0.8%
WIRE TAG #2	0.56%
WIRE TAG #3	0.28%
WIRE TAG #4	0.17%
WIRE TAG #5	0%
WIRE TAG #6	0%
TOTAL	1.810000%



1403 N 630 E  
Orem, Utah 84097  
(800) 377-4480  
BlueRavenSolar.com

**Customer Name:** Laura Gallatin  
55 Walburn Wy  
Lillington, North Carolina 27546  
**AHJ:** Harnett County  
**Utility Company:** Duke Energy NC

**PROJECT ID:** 988694

**PV DC SYSTEM SIZE:** 7.980 kW DC

**PV AC SYSTEM SIZE:** 6.175 kW AC

REVISIONS:	
A	---
B	---
C	---
D	---

**DRAWN BY:** Brendan Fillmore

**PLOT DATE:** June 15, 2024

**DRAWING TITLE:** Electrical Calculations

**DRAWING NUMBER:** PV6

# WARNING LABELS

UTILITY METER

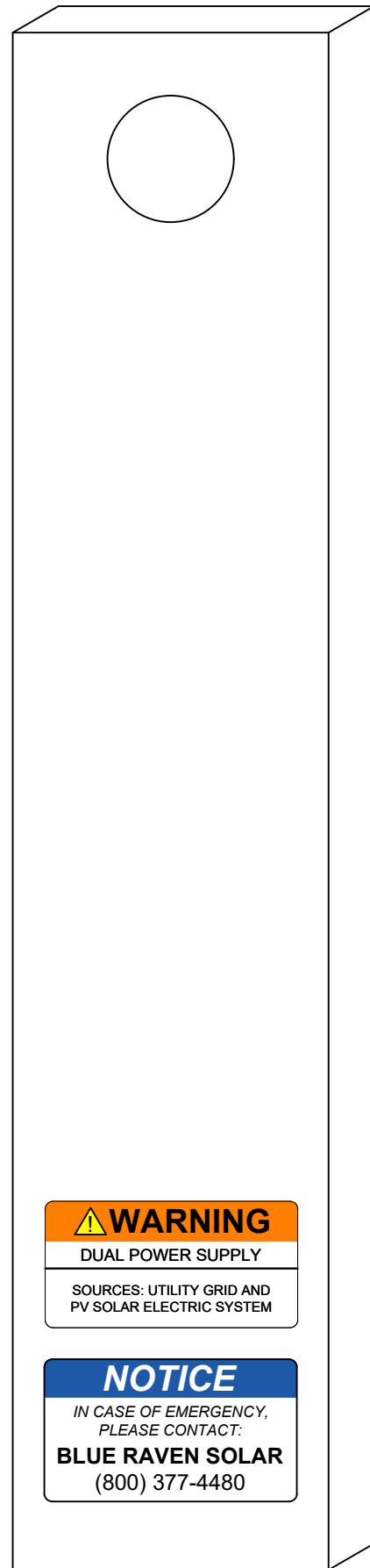

MAIN SERVICE PANEL

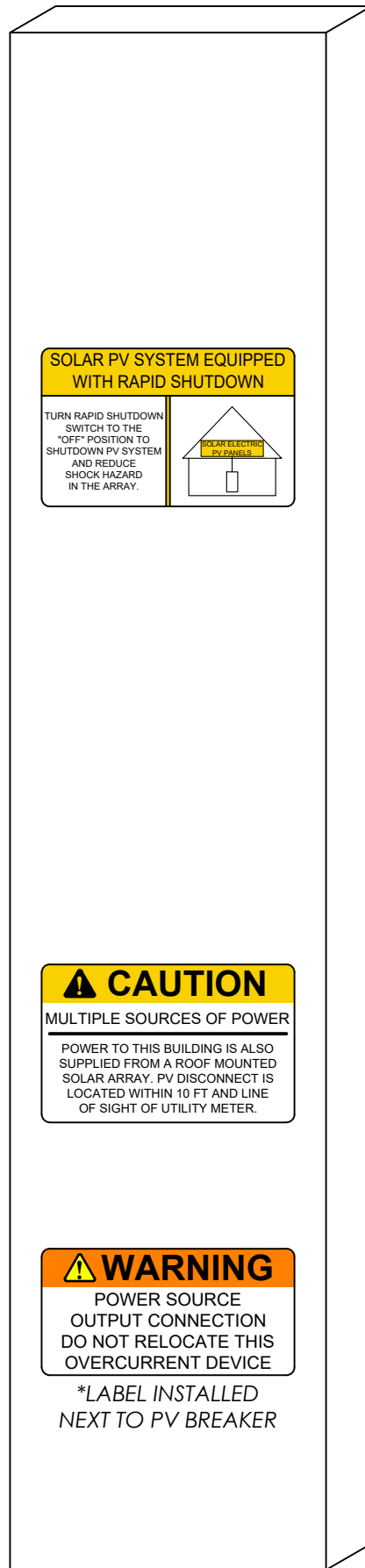

AC DISCONNECT

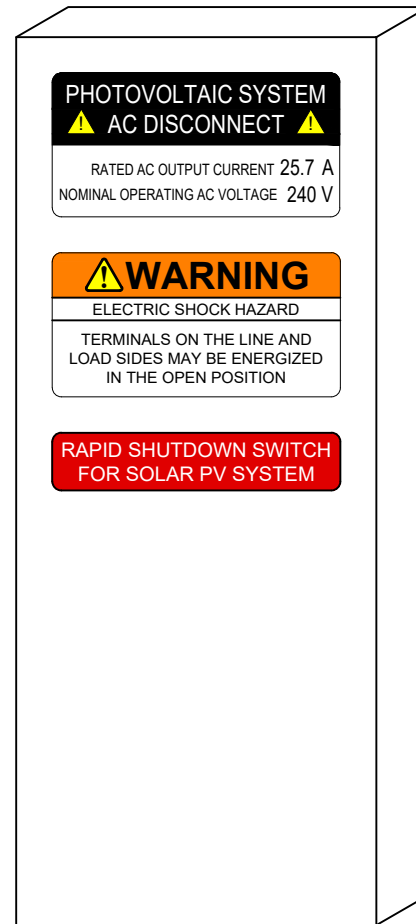

PV COMBINER BOX



1403 N 630 E  
Orem, Utah 84097  
(800) 377-4480  
BlueRavenSolar.com

**CUSTOMER NAME:** Laura Gallatin  
55 Walburn Wy  
Lillington, North Carolina 27546

**AHJ:** Harnett County

**UTILITY COMPANY:** Duke Energy NC

**PROJECT ID:** 988694

**PV DC SYSTEM SIZE:** 7.980 kW DC

**PV AC SYSTEM SIZE:** 6.175 kW AC

**REVISIONS:**

A	----
B	----
C	----
D	----

**DRAWN BY:** Brendan Fillmore

**PLOT DATE:** June 15, 2024

**DRAWING TITLE:** Warning Labels

**DRAWING NUMBER:** PV7

# SILFAB PRIME NTC

SIL-420/430 QD

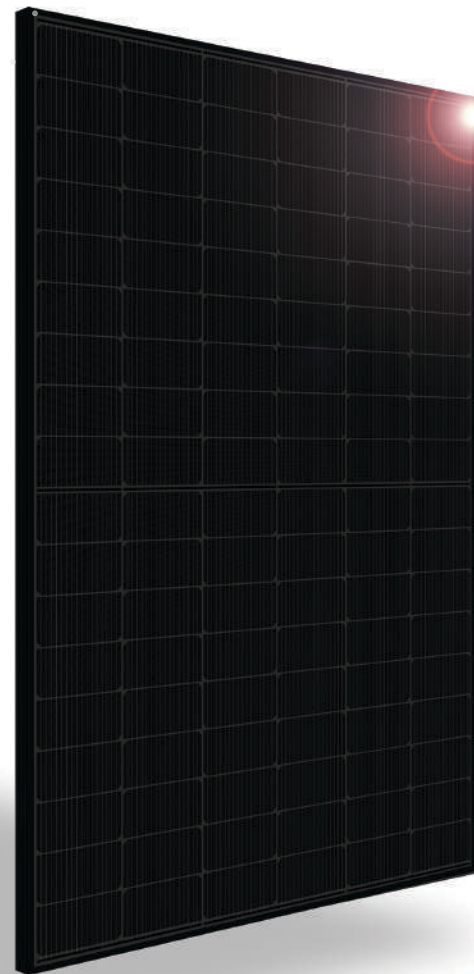

ELECTRICAL SPECIFICATIONS		420		430	
Test Conditions		STC	NOCT	STC	NOCT
Module Power (Pmax)	Wp	420	313	430	321
Maximum power voltage (Vpmax)	V	33.08	30.86	33.25	31.02
Maximum power current (Ipmax)	A	12.70	10.15	12.93	10.33
Open circuit voltage (Voc)	V	38.84	36.52	38.91	36.58
Short circuit current (Isc)	A	13.50	10.85	13.87	11.15
Module efficiency	%	21.5%	20.1%	22.1%	20.6%
Maximum system voltage (VDC)	V	1000			
Series fuse rating	A	25			
Power Tolerance	Wp	0 to +10			

Measurement conditions: STC 1000 W/m<sup>2</sup> • AM 1.5 • Temperature 25 °C • NOCT 800 W/m<sup>2</sup> • AM 1.5 • Measurement uncertainty ≤ 3%  
Sun simulator calibration reference modules from Fraunhofer Institute. Electrical characteristics may vary by ±5% and power by 0 to +10 W.

MECHANICAL PROPERTIES / COMPONENTS	METRIC	IMPERIAL
Module weight	21 kg ± 0.2 kg	46.3 lbs ± 0.4 lbs
Dimensions (H x L x D)	1721 mm x 1133 mm x 35 mm	67.8 in x 44.6 in x 1.37 in
Maximum surface load (wind/snow)*	4000 Pa rear load / 5400 Pa front load	83.5 lb/ft <sup>2</sup> rear load / 112.8 lb/ft <sup>2</sup> front load
Hail impact resistance	ø 25 mm at 83 km/h	ø 1 in at 51.6 mph
Cells	108 Half cells - N-Type Silicon solar cell 182 mm x 91 mm	108 Half cells - N-Type Silicon solar cell 7.16 in x 3.58 in
Glass	3.2 mm high transmittance, tempered, antireflective coating	0.126 in high transmittance, tempered, antireflective coating
Cables and connectors (refer to installation manual)	1350 mm, ø 5.7 mm, MC4 from Staubli	53.1 in, ø 0.22 in (12 AWG), MC4 from Staubli
Backsheet	High durability, superior hydrolysis and UV resistance, multi-layer dielectric film, fluorine-free PV backsheet	
Frame	Anodized aluminum (Black)	
Junction Box	UL 3730 Certified, IEC 62790 Certified, IP68 rated, 3 diodes	

TEMPERATURE RATINGS		WARRANTIES	
Temperature Coefficient Isc	0.04 %/°C	Module product workmanship warranty	25 years**
Temperature Coefficient Voc	-0.24 %/°C	Linear power performance guarantee	30 years
Temperature Coefficient Pmax	-0.29 %/°C		≥ 98% end 1st yr ≥ 94.7% end 12th yr ≥ 90.8% end 25th yr ≥ 89.3% end 30th yr
NOCT (± 2 °C)	45 °C		
Operating temperature	-40/+85 °C		

CERTIFICATIONS	SHIPPING SPECS						
Product	<table border="1"> <tr> <td>Modules Per Pallet:</td> <td>26 or 26 (California)</td> </tr> <tr> <td>Pallets Per Truck:</td> <td>32 or 30 (California)</td> </tr> <tr> <td>Modules Per Truck:</td> <td>832 or 780 (California)</td> </tr> </table>	Modules Per Pallet:	26 or 26 (California)	Pallets Per Truck:	32 or 30 (California)	Modules Per Truck:	832 or 780 (California)
Modules Per Pallet:	26 or 26 (California)						
Pallets Per Truck:	32 or 30 (California)						
Modules Per Truck:	832 or 780 (California)						
Factory	ISO9001:2015						

\* ⚠ Warning. Read the Safety and Installation Manual for mounting specifications and before handling, installing and operating modules.  
\*\* 12 year extendable to 25 years subject to registration and conditions outlined under "Warranty" at [silfabsolar.com](http://silfabsolar.com).  
PAN files generated from 3rd party performance data are available for download at: [silfabsolar.com/downloads](http://silfabsolar.com/downloads).

## INTRODUCING NEXT-GENERATION N-TYPE CELL TECHNOLOGY

- Improved Shade Tolerance
- Improved Low-Light Performance
- Increased Performance in High Temperatures
- Enhanced Durability
- Reduced Degradation Rate
- Industry-Leading Warranty



[SILFABSOLAR.COM](http://SILFABSOLAR.COM)

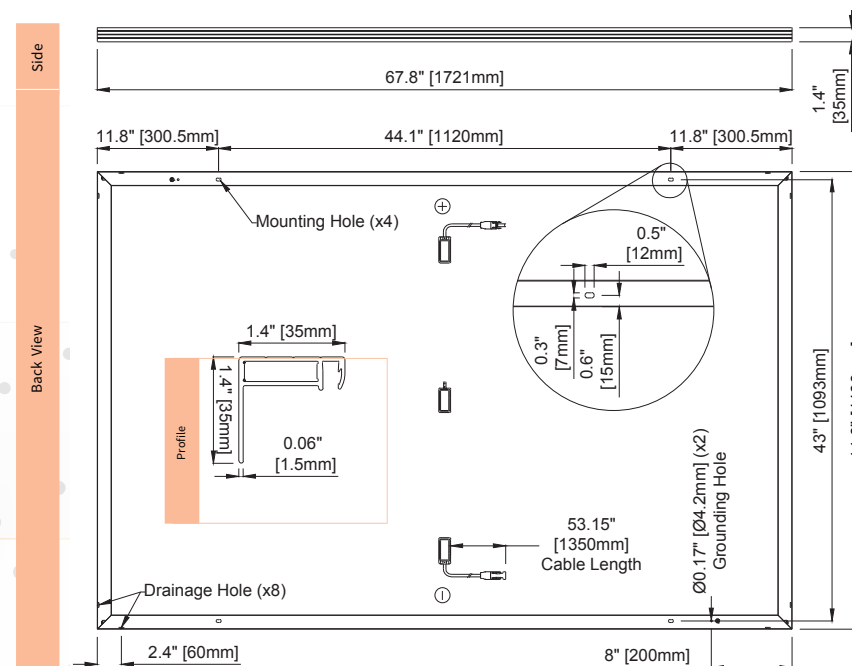

### SILFAB SOLAR INC.

1770 Port Drive  
Burlington WA 98233 USA  
T +1 360.569.4733  
info@silfabsolar.com  
[SILFABSOLAR.COM](http://SILFABSOLAR.COM)

7149 Logistics Lane  
Fort Mill SC 29715 USA  
T +1 839.400.4338

240 Courtneypark Drive East  
Mississauga ON L5T 2Y3 Canada  
T +1 905.255.2501  
F +1 905.696.0267

Silfab - SIL-420/430-QD-20240227  
No reproduction of any kind is allowed without permission.  
Data and information is subject to modifications without notice. © Silfab Solar Inc., 2022. Silfab Solar® is a registered trademark of Silfab Solar Inc.

DRAWING NUMBER:

SS





April 11<sup>th</sup>, 2024

To Whom It May Concern,

This letter is confirmation that the Silfab SIL-xxx QD module is compatible with Unirac's SFM racking system. The Silfab SIL-xxx QD module has been reviewed to ensure that, when installed with SFM, all structural and grounding and bonding features of the racking system mate properly with the module's frame. Silfab SIL-xxx QD is UL fire rated as a Type 2 module, for which the SFM system is UL 2703 certified. The Unirac product warranty applies to the installation of the Silfab SIL-xxx QD module with SFM.

Please contact Unirac with any questions.

Regards,

*Robert D'Anastasio*

Robert D'Anastasio  
Validation Engineer  
robert.danastasio@unirac.com

**Unirac, Inc. • [www.unirac.com](http://www.unirac.com)**

1411 Broadway Blvd. NE • Albuquerque, NM • 87102-1545 • Ph: (505) 242-6411 • Fax: (505) 242-6412



DRAWING NUMBER:

SS



## IQ8M and IQ8A Microinverters

Our newest IQ8 Microinverters are the industry's first microgrid-forming, software-defined microinverters with split-phase power conversion capability to convert DC power to AC power efficiently. The brain of the semiconductor-based microinverter is our proprietary application-specific integrated circuit (ASIC), which enables the microinverter to operate in grid-tied or off-grid modes. This chip is built using advanced 55-nm technology with high-speed digital logic and has superfast response times to changing loads and grid events, alleviating constraints on battery sizing for home energy systems.



Part of the Enphase Energy System, IQ8 Series Microinverters integrate with the IQ Battery, IQ Gateway, and the Enphase App monitoring and analysis software.



IQ8 Series Microinverters redefine reliability standards with more than one million cumulative hours of power-on testing, enabling an industry-leading limited warranty of up to 25 years.

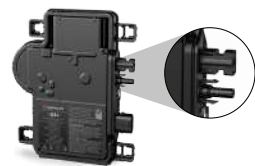

Connect PV modules quickly and easily to the IQ8 Series Microinverters that have integrated MC4 connectors.



IQ8 Series Microinverters are UL Listed as PV rapid shutdown equipment and conform with various regulations when installed according to the manufacturer's instructions.

### Easy to install

- Lightweight and compact with plug-and-play connectors
- Power line communication (PLC) between components
- Faster installation with simple two-wire cabling

### High productivity and reliability

- Produce power even when the grid is down\*
- More than one million cumulative hours of testing
- Class II double-insulated enclosure
- Optimized for the latest high-powered PV modules

### Microgrid-forming

- Complies with the latest advanced grid support\*\*
- Remote automatic updates for the latest grid requirements
- Configurable to support a wide range of grid profiles
- Meets CA Rule 21 (UL 1741-SA) and IEEE 1547:2018 (UL 1741-SB 3<sup>rd</sup> Ed.)

### NOTE:

- IQ8 Microinverters cannot be mixed together with previous generations of Enphase microinverters (IQ7 Series, IQ6 Series, and so on) in the same system.
- IQ Gateway is required to change the default grid profile at the time of installation to meet the local Authority Having Jurisdiction (AHJ) requirements.

INPUT DATA (DC)		UNITS	IQ8M-72-M-US	IQ8A-72-M-US
Commonly used module pairings <sup>1</sup>	W		260-460	295-500
Module compatibility			To meet compatibility, PV modules must be within the following maximum input DC voltage and maximum module I <sub>sc</sub> . Module compatibility can be checked at <a href="https://enphase.com/installers/microinverters/calculator">https://enphase.com/installers/microinverters/calculator</a>	
MPPT voltage range	V		30-45	32-45
Operating range	V			16-58
Minimum/Maximum start voltage	V			22/58
Maximum input DC voltage	V			60
Maximum continuous input DC current	A			12
Maximum input DC short-circuit current	A			25
Maximum module I <sub>sc</sub>	A			20
Overvoltage class DC port				II
DC port backfeed current	mA			0
PV array configuration			1 x 1 ungrounded array; no additional DC side protection required; AC side protection requires max 20 A per branch circuit	
OUTPUT DATA (AC)		UNITS	IQ8M-72-M-US	IQ8A-72-M-US
Peak output power	VA		330	366
Maximum continuous output power	VA		325	349
Nominal grid voltage (L-L)	V		240, split-phase (L-L), 180°	
Minimum and Maximum grid voltage <sup>2</sup>	V		211-264	
Maximum continuous output current	A		1.35	1.45
Nominal frequency	Hz		60	
Extended frequency range	Hz		47-68	
AC short-circuit fault current over three cycles	Arms		2	
Maximum units per 20 A (L-L) branch circuit <sup>3</sup>			11	
Total harmonic distortion	%		<5	
Overvoltage class AC port			III	
AC port backfeed current	mA		30	
Power factor setting			1.0	
Grid-tied power factor (adjustable)			0.85 leading ... 0.85 lagging	
Peak efficiency	%		97.8	97.7
CEC weighted efficiency	%		97.5	97
Nighttime power consumption	mW		21	22
MECHANICAL DATA				
Ambient temperature range			-40°C to 60°C (-40°F to 140°F)	
Relative humidity range			4% to 100% (condensing)	
DC connector type			Stäubli MC4	
Dimensions (H x W x D)			212 mm (8.3") x 175 mm (6.9") x 30.2 mm (1.2")	
Weight			1.1 kg (2.43 lbs)	
Cooling			Natural convection—no fans	
Approved for wet locations			Yes	
Pollution degree			PD3	
Enclosure			Class II double-insulated, corrosion-resistant polymeric enclosure	
Environmental category/UV exposure rating			NEMA Type 6/outdoor	

(1) No enforced DC/AC ratio.

(2) Nominal voltage range can be extended beyond nominal if required by the utility.

(3) Limits may vary. Refer to local requirements to define the number of microinverters per branch in your area.

IQ8MA-MC4-DSH-00205-2.0-EN-US-2023-11-03

\* Meets UL 1741 only when installed with IQ System Controller 2.

\*\* IQ8M and IQ8A support split-phase, 240 V installations only.

# Enphase Q Cable Accessories

The **Enphase Q Cable™** and accessories are part of the latest generation Enphase IQ System™. These accessories provide simplicity, reliability, and faster installation times.



### Enphase Q Cable

- Two-wire, double-insulated Enphase Q Cable is 50% lighter than the previous generation Enphase cable
- New cable numbering and plug and play connectors speed up installation and simplify wire management
- Link connectors eliminate cable waste

### Field-Wireable Connectors

- Easily connect Q cables on the roof without complex wiring
- Make connections from any open connector and center feed any section of cable within branch limits
- Available in male and female connector types

## Enphase Q Cable Accessories

### CONDUCTOR SPECIFICATIONS

Certification	UL3003 (raw cable), UL 9703 (cable assemblies), DG cable
Flame test rating	FT4
Compliance	RoHS, OIL RES I, CE, UV Resistant, combined UL for Canada and United States
Conductor type	THHN/THWN-2 dry/wet
Disconnecting means	The AC and DC bulkhead connectors have been evaluated and approved by UL for use as the load-break disconnect required by NEC 690.





### Q CABLE TYPES / ORDERING OPTIONS

Connectorized Models	Size / Max Nominal Voltage	Connector Spacing	PV Module Orientation	Connector Count per Box
Q-12-10-240	12 AWG / 277 VAC	1.3 m (4.2 ft)	Portrait	240
Q-12-17-240	12 AWG / 277 VAC	2.0 m (6.5 ft)	Landscape (60-cell)	240
Q-12-20-200	12 AWG / 277 VAC	2.3 m (7.5 ft)	Landscape (72-cell)	200

### ENPHASE Q CABLE ACCESSORIES

Name	Model Number	Description
Raw Q Cable	Q-12-RAW-300	300 meters of 12 AWG cable with no connectors
Field-wireable connector (male)	Q-CONN-10M	Make connections from any open connector
Field-wireable connector (female)	Q-CONN-10F	Make connections from any Q Cable open connector
Cable Clip	Q-CLIP-100	Used to fasten cabling to the racking or to secure looped cabling
Disconnect tool	Q-DISC-10	Disconnect tool for Q Cable connectors, DC connectors, and AC module mount
Q Cable sealing caps (female)	Q-SEAL-10	One needed to cover each unused connector on the cabling
Terminator	Q-TERM-10	Terminator cap for unused cable ends
Enphase EN4 to MC4 adaptor <sup>1</sup>	ECA-EN4-S22	Connect PV module using MC4 connectors to IQ micros with EN4 (TE PV4-S SOLARLOK). 150mm/5.9" to MC4.
Enphase EN4 non-terminated adaptor <sup>1</sup>	ECA-EN4-FW	For field wiring of UL certified DC connectors. EN4 (TE PV4-S SOLARLOK) to non-terminated cable. 150mm/5.9"
Enphase EN4 to MC4 adaptor (long) <sup>1</sup>	ECA-EN4-S22-L	Longer adapter cable for EN4 (TE PV4-S SOLARLOK) to MC4. Use with split cell modules or PV modules with short DC cable. 600mm/23.6"
Replacement DC Adaptor (MC4)	Q-DCC-2	DC adaptor to MC4 (max voltage 100 VDC)
Replacement DC Adaptor (UTX)	Q-DCC-5	DC adaptor to UTX (max voltage 100 VDC)

1. Qualified per UL subject 9703.

	<b>TERMINATOR</b> Terminator cap for unused cable ends, sold in packs of ten (Q-TERM-10)		<b>SEALING CAPS</b> Sealing caps for unused aggregator and cable connections (Q-BA-CAP-10 and Q-SEAL-10)
	<b>DISCONNECT TOOL</b> Plan to use at least one per installation, sold in packs of ten (Q-DISC-10)		<b>CABLE CLIP</b> Used to fasten cabling to the racking or to secure looped cabling, sold in packs of one hundred (Q-CLIP-100)

To learn more about Enphase offerings, visit [enphase.com](http://enphase.com)

To learn more about Enphase offerings, visit [enphase.com](http://enphase.com)



© 2020 Enphase Energy. All rights reserved. Enphase, the Enphase logo, Enphase IQ 7A, Enphase IQ Battery, Enphase Enlighten, Enphase IQ Envoy, and other trademarks or service names are the trademarks of Enphase Energy, Inc. Data subject to change.  
 2020-06-26



DRAWING NUMBER:

SS

# Loadcenters and Circuit Breakers

Type BR Loadcenters and Circuit Breakers

# 1.2

## Single-Phase—Main Lug Loadcenters

### Single-Phase Three-Wire—120/240 Vac—Insulated/Bondable Split Neutral, continued

Main Ampere Rating	Maximum Number 1-Inch (25.4 mm)		Enclosure Type	Box Size	Wire Size Range Cu/Al 60 °C or 75 °C for Main Lugs	Loadcenter Catalog Number ①②		
	Spaces	Circuits						
125	12	24	Indoor	X0	#6–2/0	BRP12L125 ②③④		
	12	24	Indoor	X0		BRP12L125G ②③④		
	12	24	Indoor	X0		BRP12L125DG ②③④⑤		
	12	24	Outdoor	X0R		BRP12L125R ②④⑤		
	16	32	Indoor	X1		BRP16L125 ②③④		
	16	32	Indoor	X1		BRP16L125G ②③⑤		
	16	32	Outdoor	X1R		BRP16L125R ②⑤		
	20	40	Indoor	X2		BRP20L125 ②③④		
	20	40	Indoor	X2		BRP20L125G ②③⑤		
	20	40	Outdoor	X2R		BRP20L125R ②⑤		
	24	48	Indoor	X3		BRP24L125 ②③		
	24	48	Indoor	X3		BRP24L125G ②③⑤		
	30	60	Indoor			BRP30L125 ②③		
	150	16	32	Indoor		X3	#1–300 kcmil	BRP16L150 ③
		20	40	Indoor		X3		BRP20L150 ③
20		40	Indoor	X3	BRP20L150G ③⑤			
20		40	Outdoor	X11R	BRP20L150R ④⑤			
24		48	Indoor	X4	BRP24L200 ③			
30		60	Indoor	X5	BRP30L200 ③			
200	12	24	Outdoor	X1R	#1–300 kcmil	BRP12L200R ④⑤		
	20	40	Indoor			BRP20L200 ③		
	20	40	Indoor			BRP20L200G ③⑤		
	20	40	Outdoor	X11R		BRP20L200R ⑥		
	24	48	Indoor	X4		BRP24L200 ③		
	30	60	Indoor	X5		BRP30L200 ③		
	30	60	Indoor	X5		BRP30L200G ③⑤		
	30	60	Outdoor	X5R		BRP30L200R ⑥		
400	40	80	Indoor	X6	#1–300 kcmil	BRP40L200 ③		
	40	80	Indoor	X6		BRP40L200G ③⑤		
	40	80	Outdoor	X6R		BRP40L200R ⑥		
	40	80	Outdoor	X6R		BRP40L200R ⑥		



## Single-Phase—Main Lug Loadcenters—400 and 600 A

### Single-Phase Three-Wire—120/240 Vac—Insulated/Bondable Split Neutral

Main Ampere Rating	Maximum Number 1-Inch (25.4 mm)		Enclosure Type	Box Size	Wire Size Range Cu/Al 60 °C or 75 °C for Main Lugs	Commercial Loadcenter Catalog Number ①	
	Spaces	Circuits				With Flush or NEMA Type 3R Cover	With Surface Cover
400	12	24	Outdoor	42	(2) #3/0–400 kcmil	BR1224L400R ③⑤	—
	42	42	Indoor	22		BR4242L400F	BR4242L400S
	42	42	Outdoor	46		BR4242L400R ④	—
600	42	42	Indoor	22	(2) #2–500 kcmil	—	BR4242L600S



- Notes**
- ① Ground bar kits priced separately unless otherwise noted. See Page V1-T1-71.
  - ② Has provision for BRPHD hold-down kit in 125A and 200A styles.
  - ③ Combination cover style.
  - ④ Suitable for use as service equipment when not more than six main disconnecting means are provided.
  - ⑤ Ground bars installed.
  - ⑥ Rainproof panels are furnished with hub closure plates. For rainproof hubs, refer to Page V1-T1-71.
  - ⑦ Includes main lugs. Loadcenters can convert to main breaker using kit.

# 1.2 Loadcenters and Circuit Breakers

Type BR Loadcenters and Circuit Breakers

Approximate Dimensions in Inches (mm)

## Commercial Loadcenters—NEMA Type 1 Indoor

Box Size	Height	Width	Depth
19	44.00 (1117.6)	16.16 (410.4)	6.25 (158.8)
20	44.00 (1117.6)	16.16 (410.4)	6.25 (158.8)
22	54.00 (1371.6)	16.22 (412.0)	6.31 (160.3)
24	66.50 (1689.1)	16.22 (412.0)	6.31 (160.3)

## Commercial Loadcenters—NEMA Type 3R Outdoor

Box Size	Height	Width	Depth
42	38.00 (965.2)	16.31 (414.3)	6.38 (161.9)
43	44.00 (1117.6)	16.31 (414.3)	6.38 (161.9)
46	54.00 (1371.6)	16.31 (414.3)	6.38 (161.9)
47	66.56 (1690.7)	16.31 (414.3)	6.38 (161.9)

## New York City Loadcenters—NEMA Type 1 Indoor

Box Size	Height	Width	Depth
A	38.00 (965.2)	18.13 (460.4)	5.00 (127.0)
B	44.00 (1117.6)	18.13 (460.4)	5.00 (127.0)
C	66.50 (1689.1)	18.13 (460.4)	6.25 (158.8)

## ECC Unit Enclosures—NEMA Type 1 Indoor

Height	Width	Depth
23.25 (590.6)	8.88 (225.4)	4.50 (114.3)

## ECC Unit Enclosures—NEMA Type 3R Outdoor

Height	Width	Depth
23.68 (601.7)	9.31 (236.5)	5.44 (138.1)

## Residential Loadcenter Knockouts

### Knockouts for Box Sizes A1, B1, B2, C1, C2, C4, D1, G1, L1, L2, B1R, B2R, C1R, C3R, D1R, G1R, L1R, L2R

Code	Diameter				
A	0.50 (12.7)	0.75 (19.1)	—	—	—
B	0.50 (12.7)	—	—	—	—
C	0.50 (12.7)	1.25 (31.8)	1.50 (38.1)	2.00 (50.8)	2.50 (63.5)
D	1.25 (31.8)	1.25 (31.8)	2.00 (50.8)	2.50 (63.5)	—
E	0.50 (12.7)	0.75 (19.1)	1.00 (25.4)	—	—
F	0.50 (12.7)	0.75 (19.1)	1.00 (25.4)	1.50 (38.1)	2.00 (50.8)
G	1.25 (31.8)	1.50 (38.1)	2.00 (50.8)	—	—
H	0.50 (12.7)	0.75 (19.1)	1.00 (25.4)	1.25 (31.8)	1.50 (38.1)
I	1.00 (25.4)	1.25 (31.8)	1.50 (38.1)	2.00 (50.8)	2.50 (63.5)
J	1.00 (25.4)	1.25 (31.8)	1.50 (38.1)	—	—

## Residential NEMA Type 1 Indoor and NEMA Type 3R Outdoor Enclosures

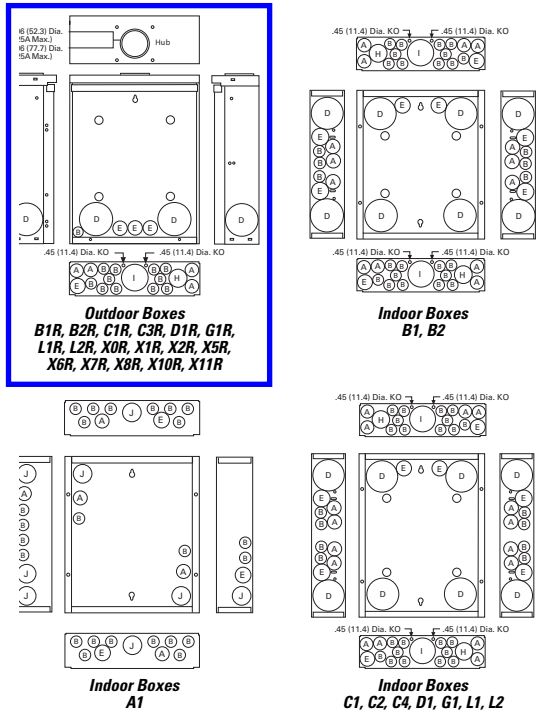

1403 N. Research Way  
Orem, UT 84097  
800.377.4480  
WWW.BLUERAVENSOLAR.COM

CONFIDENTIAL- THE INFORMATION HEREIN CONTAINED SHALL NOT BE USED FOR THE BENEFIT OF ANYONE EXCEPT BLUE RAVEN SOLAR NOR SHALL IT BE DISCLOSED IN WHOLE OR IN PART TO OTHERS OUTSIDE RECIPIENTS ORGANIZATION, EXCEPT IN CONNECTION WITH THE SALE AND USE OF THE RESPECTIVE EQUIPMENT, WITHOUT THE WRITTEN PERMISSION OF BLUE RAVEN SOLAR LLC.

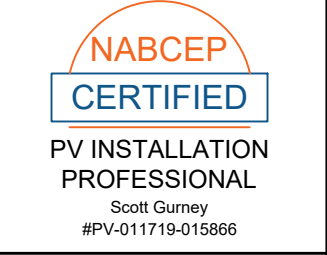

CONTRACTOR:  
BRS FIELD OPS  
385-498-6700

DRAWING BY:

PLOT DATE:

PROJECT NUMBER:

SHEET NAME:  
**SPEC SHEET**

REVISION: **----** PAGE NUMBER: **SS**

# Enphase IQ Envoy

The **Enphase IQ Envoy™** communications gateway delivers solar production and energy consumption data to Enphase Enlighten™ monitoring and analysis software for comprehensive, remote maintenance and management of the Enphase IQ System.

With integrated revenue grade production metering and optional consumption monitoring, Envoy IQ is the platform for total energy management and integrates with the Enphase Ensemble™ and the Enphase IQ Battery™.



### Smart

- Enables web-based monitoring and control
- Bidirectional communications for remote upgrades
- Supports power export limiting and zeroexport applications

### Simple

- Easy system configuration using Enphase Installer Toolkit™ mobile app
- Flexible networking with Wi-Fi, Ethernet, or cellular

### Reliable

- Designed for installation indoors or outdoors
- Five-year warranty

## Enphase IQ Envoy

### MODEL NUMBERS

Enphase IQ Envoy™ ENV-IQ-AM1-240	Enphase IQ Envoy communications gateway with integrated revenue grade PV production metering (ANSI C12.20 +/- 0.5%) and optional consumption monitoring (+/- 2.5%). Includes one 200A continuous rated production CT (current transformer).
-------------------------------------	---

### ACCESORIES (Order Separately)

Enphase Mobile Connect™ CELLMODEM-M1 (4G based LTE-M/5-year data plan) CELLMODEM-M1-B (4G-based LTE-M1/5-year data plan)	Plug and play industrial grade cellular modem with data plan for systems up to 60 microinverters. (Available in the US, Canada, Mexico, Puerto Rico, and the US Virgin Islands, where there is adequate cellular service in the installation area.)
Consumption Monitoring CT CT-200-SPLIT	Split-core consumption CTs enable whole home metering.
Ensemble Communications Kit COMMS-KIT-01	Installed at the IQ Envoy. For communications with Enphase Encharge™ storage and Enphase Enpower™ smart switch. Includes USB cable for connection to IQ Envoy or Enphase IQ Combiner™ and allows wireless communication with Encharge and Enpower.

### POWER REQUIREMENTS

Power requirements	120/240 VAC split-phase. Max 20 A overcurrent protection required.
Typical Power Consumption	5W

### CAPACITY

Number of microinverters polled	Up to 600
---------------------------------	-----------

### MECHANICAL DATA

Dimensions (WxHxD)	21.3 x 12.6 x 4.5 cm (8.4" x 5" x 1.8")
Weight	17.6 oz (498 g)
Ambient temperature range	-40° to 65° C (-40° to 149° F) -40° to 46° C (-40° to 115° F) if installed in an enclosure
Environmental rating	IP30. For installation indoors or in an NRTL-certified, NEMA type 3R enclosure.
Altitude	To 2000 meters (6,560 feet)
Production CT	- Limited to 200A of continuous current / 250A OCPD – 72kW AC - Internal aperture measures 19.36mm to support 250MCM THWN conductors (max) - UL2808 certified for revenue grade metering
Consumption CT	- For electrical services to 250A with parallel runs up to 500A - Internal aperture measures 0.84" x 0.96" (21.33mm x 24.38mm) to support 3/0 THWN conductor - UL2808 certified, for use at service entrance for services up to 250Vac

### INTERNET CONNECTION OPTIONS

Integrated Wi-Fi	802.11b/g/n
Ethernet	802.3, Cat5E (or Cat 6) UTP Ethernet cable (not included)
Mobile	CELLMODEM-M1 (4G) or CELLMODEM-M1-B (4G). Not included. Note that an Enphase Mobile Connect cellular modem is required for all Ensemble installations.

### COMPLIANCE

Compliance	UL 61010-1 CAN/CSA C22.2 No. 61010-1 47 CFR, Part 15, Class B, ICES 003 IEC/EN 61010-1:2010, EN50065-1, EN61000-4-5, EN61000-6-1, EN61000-6-2 Metering: ANSI C12.20 accuracy class 0.5 (PV production only)
------------	--



1403 N. Research Way  
Orem, UT 84097

800.377.4480  
WWW.BLUERAVENSOLAR.COM

CONFIDENTIAL- THE INFORMATION HEREIN CONTAINED SHALL NOT BE USED FOR THE BENEFIT OF ANYONE EXCEPT BLUE RAVEN SOLAR NOR SHALL IT BE DISCLOSED IN WHOLE OR IN PART TO OTHERS OUTSIDE RECIPIENTS ORGANIZATION, EXCEPT IN CONNECTION WITH THE SALE AND USE OF THE RESPECTIVE EQUIPMENT, WITHOUT THE WRITTEN PERMISSION OF BLUE RAVEN SOLAR LLC.



PV INSTALLATION  
PROFESSIONAL  
Scott Gurney  
#PV-011719-015866

CONTRACTOR:  
BRS FIELD OPS  
385-498-6700

DRAWING BY:

PLOT DATE:

PROJECT NUMBER:

SHEET NAME:

**SPEC SHEET**

REVISION:

----

PAGE NUMBER:

**SS**



To learn more about Enphase offerings, visit [enphase.com](http://enphase.com)



To learn more about Enphase offerings, visit [enphase.com](http://enphase.com)

© 2021 Enphase Energy. All rights reserved. Enphase, the Enphase logo, IQ Envoy, and other trademarks or service names are the trademarks of Enphase Energy, Inc. Data subject to change. 06-30-2021



CONFIDENTIAL- THE INFORMATION HEREIN CONTAINED SHALL NOT BE USED FOR THE BENEFIT OF ANYONE EXCEPT BLUE RAVEN SOLAR NOR SHALL IT BE DISCLOSED IN WHOLE OR IN PART TO OTHERS OUTSIDE RECIPIENTS ORGANIZATION, EXCEPT IN CONNECTION WITH THE SALE AND USE OF THE RESPECTIVE EQUIPMENT, WITHOUT THE WRITTEN PERMISSION OF BLUE RAVEN SOLAR LLC.



**PV INSTALLATION  
PROFESSIONAL**

Scott Gurney  
#PV-011719-015866

**CONTRACTOR:  
BRS FIELD OPS  
385-498-6700**

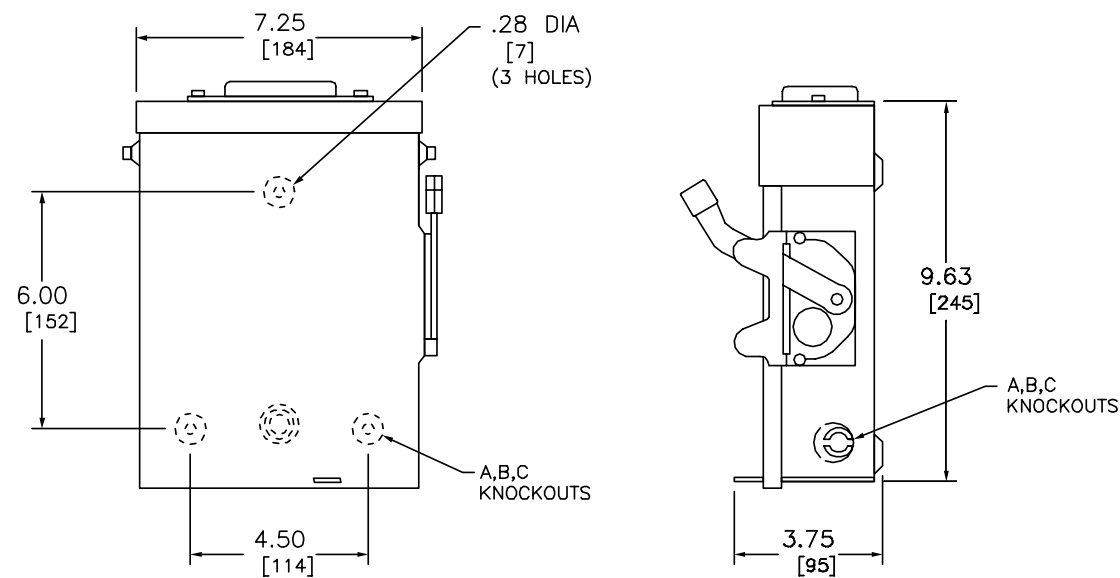

NEMA TYPE 3R

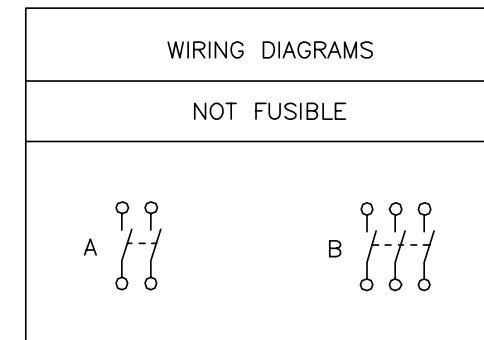

TERMINAL LUGS ‡			
AMPERES	MAX. WIRE	MIN. WIRE	TYPE
60	# 2 AWG	#10 AWG	AL
	# 2 AWG	#14 AWG	CU

KNOCKOUTS				
SYMBOL	A	B	C	D
CONDUIT SIZE	.50	.75	1	1.25

DUAL DIMENSIONS: INCHES  
MILLIMETERS

CATALOG NUMBER	VOLTAGE RATINGS	WIRING DIAG.	HORSEPOWER RATINGS	
			240VAC	
			MAX.	
			1 Ø	3 Ø
DU222RB	240VAC	A	10	—
DU322RB	240VAC	B	10	15

NOTES:  
FINISH — GRAY BAKED ENAMEL  
UL LISTED — FILE E-2875  
SUITABLE FOR USE AS SERVICE EQUIPMENT  
TOP OF NEMA TYPE 3R SWITCHES HAVE PROVISIONS FOR MAXIMUM 2 1/2" BOLT-ON HUB.  
SHORT CIRCUIT CURRENT RATINGS:  
10,000 AMPERES WHEN USED WITH OR PROTECTED BY CLASS H OR K FUSES  
100,000 AMPERES WHEN USED WITH OR PROTECTED BY CLASS R FUSES.  
‡ LUGS SUITABLE FOR 60°C OR 75°C COPPER OR ALUMINUM CONDUCTORS.

GENERAL DUTY SAFETY SWITCHES  
VISIBLE BLADE TYPE  
60 AMPERE  
ENCLOSURE — NEMA TYPE 3R RAINPROOF



DWG# 1861  
NO.

DRAWING BY:

PLOT DATE:

PROJECT NUMBER:

SHEET NAME:

**SPEC SHEET**

REVISION:

----

PAGE NUMBER:

**SS**

### A. System Specifications and Ratings

- Maximum Voltage: 1,000 Volts
- Maximum Current: 80 Amps
- Allowable Wire: 14 AWG – 6 AWG
- Spacing: Please maintain a spacing of at least 1/2" between uninsulated live parts and fittings for conduit, armored cable, and uninsulated live parts of opposite polarity.
- Enclosure Rating: Type 3R
- Roof Slope Range: 2.5 – 12:12
- Max Side Wall Fitting Size: 1"
- Max Floor Pass-Through Fitting Size: 1"
- Ambient Operating Conditions: (-35°C) - (+75°C)
- Compliance:
  - JB-1.2: UL1741
  - Approved wire connectors: must conform to UL1741
- System Marking: **Interek Symbol and File #5019942**
- Periodic Re-inspections: If re-inspections yield loose components, loose fasteners, or any corrosion between components, components that are found to be affected are to be replaced immediately.

ITEM NO.	PART NUMBER	DESCRIPTION	QTY
1	JB-1.2 BODY	POLYCARBONATE WITH UV INHIBITORS	1
2	JB-1.2 LID	POLYCARBONATE WITH UV INHIBITORS	1
3	#10 X 1-1/4" PHILLIPS PAN HEAD SCREW		6
4	#8 X 3/4" PHILLIPS PAN HEAD SCREW		6

SIZE	DWG. NO.	REV
<b>B</b>	JB-1.2	
SCALE: 1:2	WEIGHT: 1.45 LBS	SHEET 1 OF 3

TORQUE SPECIFICATION:	15-20 LBS
CERTIFICATION:	UL STANDARD 1741, NEMA 3R
WEIGHT:	1.45 LBS

Table 1: Typical Wire Size, Torque Loads and Ratings

	1 Conductor	2 Conductor	Torque				
			Type	NM	Inch Lbs	Voltage	Current
ABB ZS6 terminal block	10-24 awg	16-24 awg	Sol/Str	0.5-0.7	6.2-8.85	600V	30 amp
ABB ZS10 terminal block	6-24 awg	12-20 awg	Sol/Str	1.0-1.6	8.85-14.16	600V	40 amp
ABB ZS16 terminal block	4-24 awg	10-20 awg	Sol/Str	1.6-2.4	14.6-21.24	600V	60 amp
ABB M6/8 terminal block	8-22 awg		Sol/Str	.08-1	8.85	600V	50 amp
Ideal 452 Red WING-NUT Wire Connector	8-18 awg		Sol/Str	Self Torque	Self Torque	600V	
Ideal 451 Yellow WING-NUT Wire Connector	10-18 awg		Sol/Str	Self Torque	Self Torque	600V	
Ideal, In-Sure Push-In Connector Part #39	10-14 awg		Sol/Str	Self Torque	Self Torque	600V	
WAGO, 2204-1201	10-20 awg	16-24 awg	Sol/Str	Self Torque	Self Torque	600V	30 amp
WAGO, 221-612	10-20 awg	10-24 awg	Sol/Str	Self Torque	Self Torque	600V	30 amp
Dottie DRC75	6-12 awg		Sol/Str	Snap-In	Snap-In		
ESP NG-53	4-6 awg		Sol/Str		45	2000V	
	10-14 awg		Sol/Str		35		
ESP NG-717	4-6 awg		Sol/Str		45	2000V	
	10-14 awg		Sol/Str		35		
Brumall 4-5,3	4-6 awg		Sol/Str		45	2000V	
	10-14 awg		Sol/Str		35		

Table 2: Minimum wire-bending space for conductors through a wall opposite terminals in mm (inches)

Wire size, AWG or kcmil (mm2)	Wires per terminal (pole)			
	1	2	3	4 or More
	mm (inch)	mm (inch)	mm (inch)	mm (inch)
14-10 (2.1-5.3)	Not specified	-	-	-
8 (8.4)	38.1 (1-1/2)	-	-	-
6 (13.3)	50.8 (2)	-	-	-

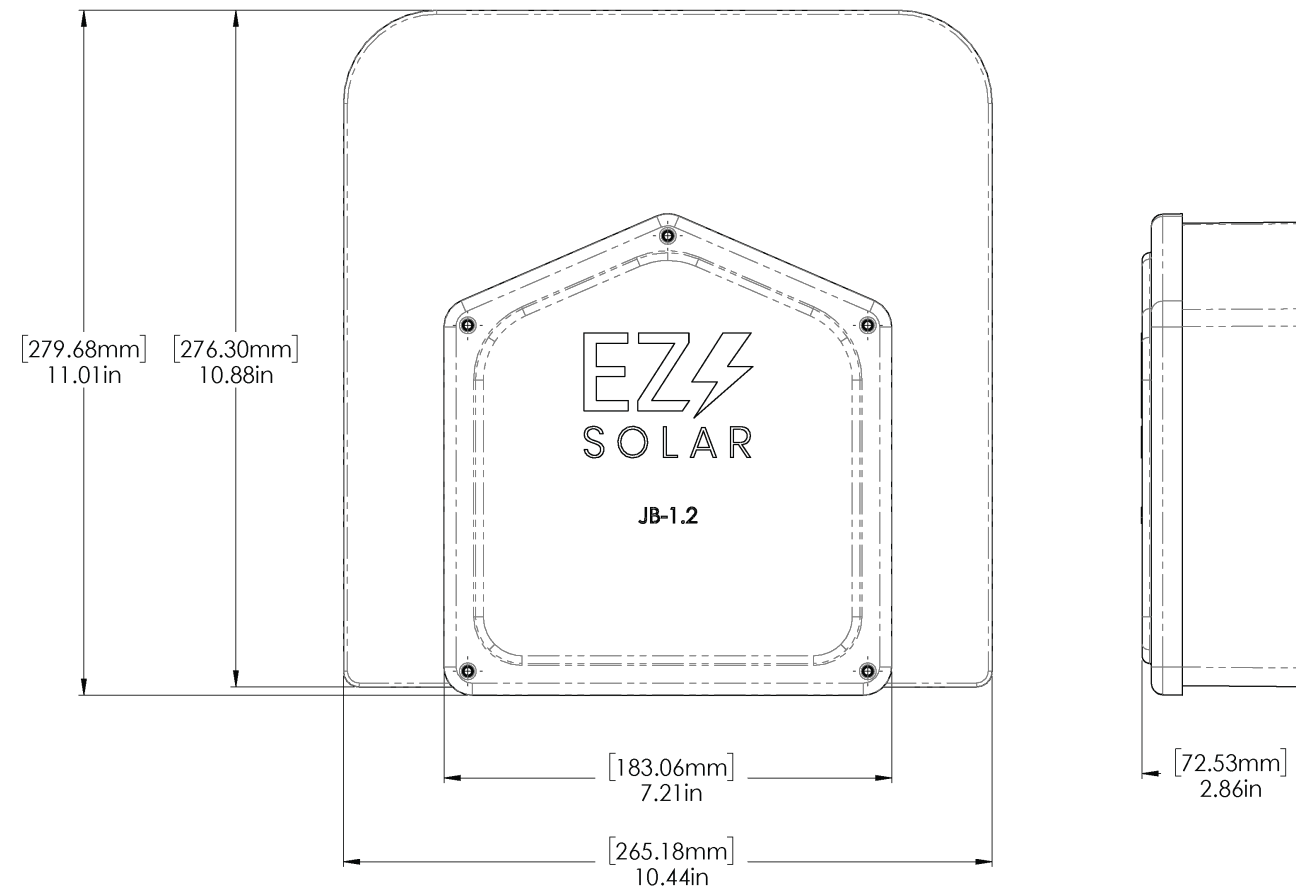

CONTRACTOR:  
BRS FIELD OPS  
385-498-6700

DRAWING BY:

PLOT DATE:

PROJECT NUMBER:

SHEET NAME:

**SPEC SHEET**

REVISION:

----

PAGE NUMBER:

**SS**

# Rigid Nonmetallic Conduit – Junction Boxes

## Molded Nonmetallic Junction Boxes 6P Rated

It's another first from Carlon® - the first nonmetallic junction boxes UL Listed with a NEMA 6P rating per Section 314.29, Exception of the National Electrical Code. Manufactured from PVC or PPO thermoplastic molding compound and featuring foam-in-place gasketed lids attached with stainless steel screws, these rugged enclosures offer all the corrosion resistance and physical properties you need for direct burial applications.

Type 6P enclosures are intended for indoor or outdoor use, primarily to provide a degree of protection against contact with enclosed equipment, falling dirt, hose-directed water, entry of water during prolonged submersion at a limited depth, and external ice formation.

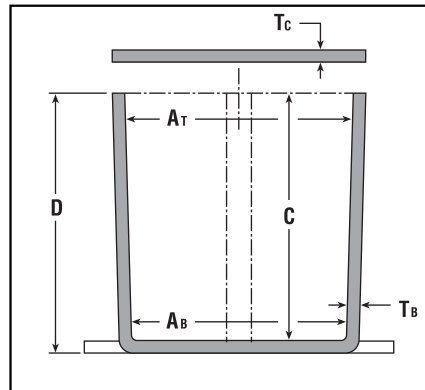
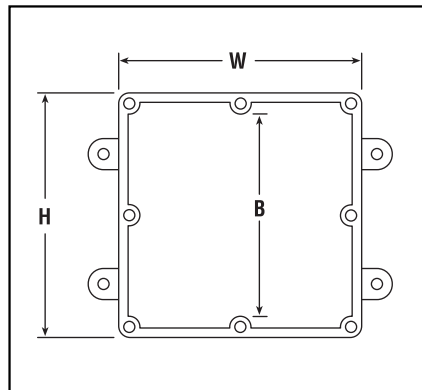

- All Carlon Junction Boxes are UL Listed and maintain a minimum of a NEMA Type 4/4x Rating.
- Parts numbers with an asterisk (\*) are UL Listed and maintain a NEMA Type 6P Rating and Type 4/4X Rating.

Part No.	Size in Inches H x W x D	Std. Ctn. Qty.	Min. At	Min. Ab	Min. B	Min. C	Ta	Tc Typical	Material		Std. Ctn. Wt. (Lbs.)
									PVC	Thermo-plastic	
E989NNJ-CAR*	4 x 4 x 2	5	3 11/16	3 5/8	N/A	2	.160	.155	X		3
E987N-CAR*	4 x 4 x 4	5	3 11/16	3 1/2	N/A	4	.160	.155	X		4
†E989NNR-CAR*	4 x 4 x 6	4	3 11/16	3 3/8	N/A	6	.160	.200	X		5
E989PPJ-CAR*	5 x 5 x 2	4	4 11/16	4 1/2	N/A	2	.110	.150		X	3
E987R-CAR*	6 x 6 x 4	2	6	5 5/8	N/A	4	.190	.190		X	3
E989RRR-UPC*	6 x 6 x 6	8	5 5/8	5 3/8	N/A	6	.160	.150		X	14
E989N-CAR	8 x 8 x 4	1	8	8	N/A	4	.185	.190		X	2
E989SX-UPC	8 x 8 x 7	2	7 21/32	7 5/16	N/A	7	.160	.150		X	6
E989UUN	12 x 12 x 4	3	11 5/8	11 1/2	11 1/8	4	.160	.150		X	12
E989R-UPC	12 x 12 x 6	2	11 5/16	11 7/8	11 7/16	6	.265	.185		X	10

VIEW SHOWN LESS COVER FOR CLARITY

SECTION A-A  
SCALE 0.500

SIZE	A	B	C
E989NNJ E989NNJB E989NNJ-CAR E989NNJCL E989NNJL (4x4x2)	2.00 (50.8)	4.63 (117.6)	5.13 (130.2)
E989NNR E989NNR-CAR (4x4x6)	6.00 (152.4)	5.00 (127.0)	5.50 (139.1)

NOTES:  
1. MATERIAL: PVC  
2. NEMA TYPES: 4/4X, 6P

**GENERAL NOTES**

- ALL DIMENSIONS ARE FOR REFERENCE ONLY.
- DIMENSIONS IN BRACKETS ( ) ARE IN METRIC UNITS.

**REVISIONS**

F	SEE ERN 2016195 FOR APPROVAL SIGNATURES & RELEASE DATE. PROJECT NO: 5AM000006
---	---

**Thomas & Betts**  
www.tnb.com

DESCRIPTION: **MOLDED NON-METALLIC ENCLOSURE**

ORIGINAL PROJECT NO / ( ERN NO )	SHEET NO:	REV. NO:	DRAWING NO:
/ ( )	2 OF 2	F	WSD-AC01977

THIS DRAWING IS INTENDED FOR DESCRIPTIVE PURPOSES ONLY. AND THE RIGHT IS RESERVED TO DEViate FROM ANY OF THE DETAILS SHOWN HEREON. Copyright Thomas & Betts - Proprietary. All Rights Reserved.



1403 N. Research Way  
Orem, UT 84097  
800.377.4480  
WWW.BLUERAVENSOLAR.COM

CONFIDENTIAL- THE INFORMATION HEREIN CONTAINED SHALL NOT BE USED FOR THE BENEFIT OF ANYONE EXCEPT BLUE RAVEN SOLAR NOR SHALL IT BE DISCLOSED IN WHOLE OR IN PART TO OTHERS OUTSIDE RECIPIENTS ORGANIZATION, EXCEPT IN CONNECTION WITH THE SALE AND USE OF THE RESPECTIVE EQUIPMENT, WITHOUT THE WRITTEN PERMISSION OF BLUE RAVEN SOLAR LLC.



CONTRACTOR:  
BRS FIELD OPS  
385-498-6700

DRAWING BY:

PLOT DATE:

PROJECT NUMBER:

SHEET NAME:  
**SPEC SHEET**

REVISION: **----** PAGE NUMBER: **SS**



“Stay Connected” with **HEYCO** Solar Power Components  
a PennEngineering® Company

## Heyco®-Tite Liquid Tight Cordgrips for Enphase Q Cables

Straight-Thru, NPT Hubs with Integral Sealing Ring

*The Ultimate in Liquid Tight Strain Relief Protection*

ALL NEW  
PRODUCT!



GLAND CONFIGURATION Conductors	PART NO.	DESCRIPTION	UL/CSA or SAUS	PART DIMENSIONS											
				A Clearance Hole Dia.	B Max. O.A. Length	C Thread Length	D Wrenching Nut Thickness	E Flat Size							
Type * Size mm.	No. Black			in.   mm.	in.   mm.	in.   mm.	in.   mm.	in.   mm.							
<b>Oval Gland</b>															
Q Cable	6,1 x 9,7	1	M3231GCZ	LTCG 1/2 6.1x9.7MM	UL/CSA	.875	22,2	1.70	43,2	.61	15,5	.21	5,3	.98	24,9
<b>Break-Thru Skinned Over Gland</b>															
Q Cables plus Ground	6,1 x 9,7 3,3	2 1	M3234GDA-SM	SMCG 3/4 2-6.1x9.7MM 1-3.3MM	UL/CSA	1.040	26,4	2.00	50,8	.62	15,7	.25	6,4	1.30	33,0

Metal Locknuts INCLUDED.

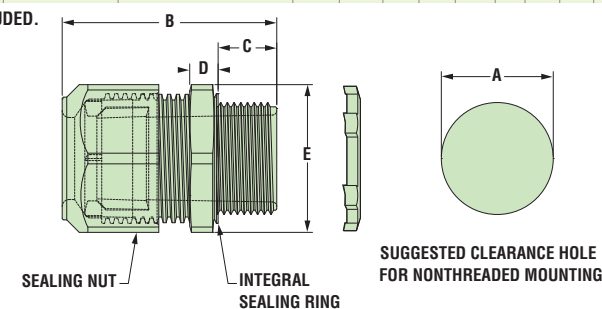

Material	Nylon 6/6 with TPE Sealing Gland
Certifications	UL Listed under Underwriters' Laboratories File E504900 CSA Certified by the Canadian Standards Association File 93876
Flammability Rating	94V-2
Temperature Range	Static -40°F (-40°C) to 239°F (115°C) Dynamic -4°F (-20°C) to 212°F (100°C)
IP Rating	IP 68

- Two new cordgrips now accommodate the Enphase Q Cable – M3231GCZ (1/2" NPT) and M3234GDA-SM (3/4" NPT).
- The 1/2" version provides liquid tight entry for one Enphase Q Cable – .24 x .38" (6,1 x 9,7 mm).
- The 3/4" version provides liquid tight entry for up to two Enphase Q Cables – .24 x .38" (6,1 x 9,7 mm) and an additional .130" (3,3 mm) dia. hole for a #8 solid grounding cable.
- The 3/4" version utilizes our skinned-over technology so any unused holes will retain a liquid tight seal.
- Rated for use with DG Cable.

## Heyco® Helios® UVX Clip – Blind Mount

ALL NEW  
PRODUCT!



PANEL THICKNESS RANGE		WIRE DIAMETER RANGE 1-2 Wires		PART NO.	DESCRIPTION	MOUNTING HOLE DIA. A		OVERALL HEIGHT C		
Minimum in.   mm.	Maximum in.   mm.	Minimum in.   mm.	Maximum in.   mm.			in.   mm.	in.   mm.	in.   mm.	in.   mm.	
<b>1-2 Wires</b>										
.028	0,7	.250	6,4	.23 (5,8 mm) - .32 (8,0 mm) each cable	S6520 S6560	Helios UVX Clip 100 Pack Helios UVX Clip Bulk	.260	6,6	.96	24,4

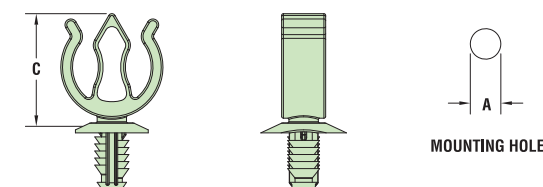

Material	Nylon 6/6 with extended UV Capabilities
Flammability Rating	94V-2
Temperature Range	Dynamic -4°F (-20°C) to 185°F (85°C)

- The jersey pine tree mounting style installs easily with superior holding power.
- UVX nylon protects from corrosion due to outdoor exposure.
- Installs into .260" (6,6 mm) mounting hole.
- Holds up to 2 cables between .230 - .315" (5,8 - 8,0 mm) each.
- Cables install with fingertip pressure.
- Molded from our robust UVX nylon 6/6 with extended UV capabilities for our Solar 20 Year Warranty.

# SFM INFINITY

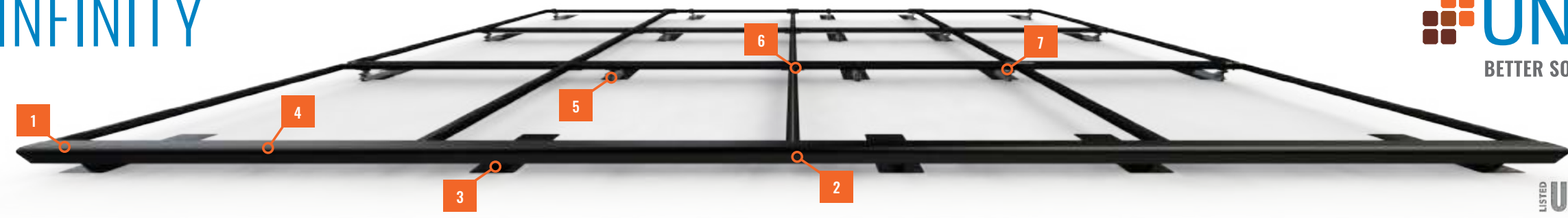

LISTED **UL2703** LOADING & GROUNDING MECHANICAL LEADING SYSTEM FIRE CLASSIFICATION



## 2 INSTALLS PER DAY

Make two installs per day your new standard. **SFM INFINITY** has fewer roof attachments, one tool installation, and pre-assembled components to get you off the roof 40% faster.

**87%** OF HOMEOWNERS PREFER

## BETTER AESTHETICS





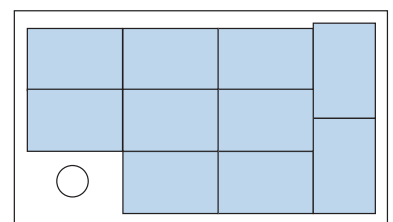

Install the system with the aesthetics preferred by homeowners, with integrated front trim, trim end caps, dark components, and recessed hardware.

## MAXIMUM POWER DENSITY



Easily mix module orientations to achieve optimal power density without incurring the increased bill of materials, labor, and attachments required by rail.



## SYSTEM OVERVIEW

	PART NAME	DESCRIPTION
1	 TRIMRAIL	Structural front trim provides aesthetic and aligns modules.
2	 TRIMRAIL SPLICE	Connects and electrically bonds sections of TRIMRAIL.
3	 TRIMRAIL FLASHKIT	Attaches TRIMRAIL to roof. Available for comp shingle or tile.
4	 MODULE CLIPS	Secure modules to TRIMRAIL.
5	 MICRORAIL	Connects modules to SLIDERS. Provides post-install array leveling.
6	 SPLICE	Connects and supports modules. Provides east-west bonding. ATTACHED SPLICE also available.
7	 SLIDER FLASHKIT	Roof attachment and flashing. Available for comp shingle and tile.

## BONDING AND ACCESSORIES

	PART NAME	DESCRIPTION
	 TRIMRAIL ENDCAPS	Covers ends of TRIMRAIL for refined aesthetic.
	 TRIMRAIL BONDING CLAMP	Electrically bonds TRIMRAIL and modules
	 N/S BONDING CLAMP	Electrically bonds rows of modules

## 20% FEWER ATTACHMENTS

Save time and money on every project: **SFM INFINITY** requires fewer attachments than rail systems.

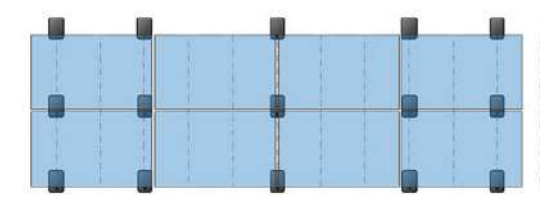

SFM INFINITY 15 Attachments

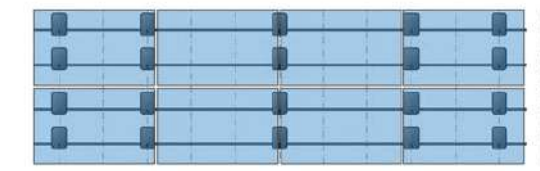

RAIL 20 Attachments

## 30% LOGISTICS SAVINGS

With fewer SKUs and compact components, **SFM INFINITY** is easier to stock, easier to transport, and easier to lift to the roof. Plus, make more efficient use of your vehicle fleet.



**SFM INFINITY REVOLUTIONIZES ROOFTOP SOLAR WITH BENEFITS ACROSS YOUR BUSINESS, FROM DESIGN AND LOGISTICS, THROUGH ARRAY INSTALLATION AND SERVICE.**

DRAWING NUMBER:

**SS**

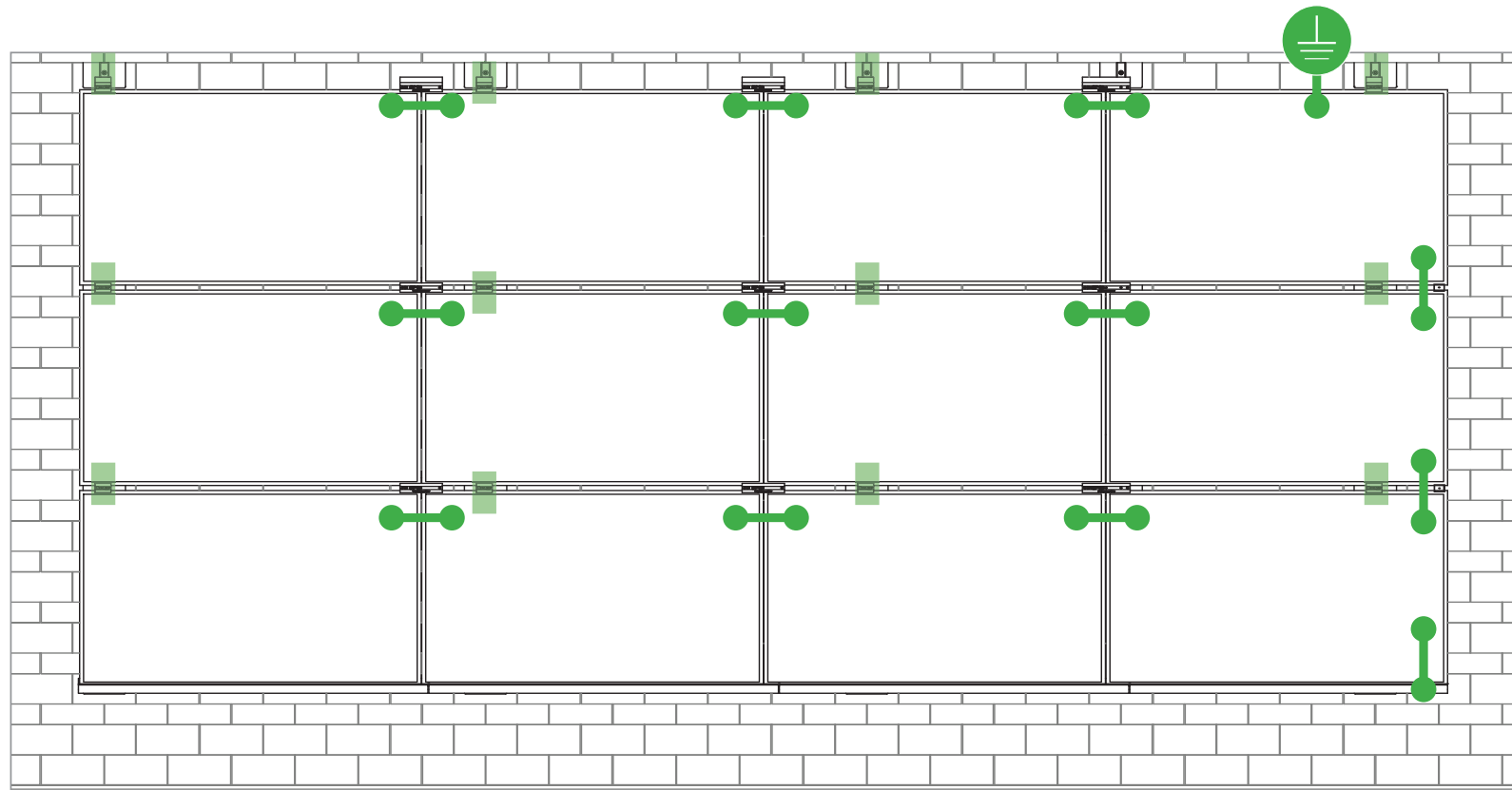

Star Washer is Single Use Only

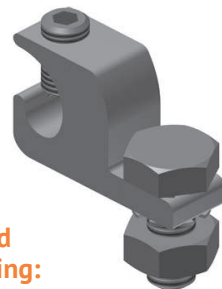

**TERMINAL TORQUE,**  
Install Conductor and torque to the following:  
4-6 AWG: 35in-lbs  
8 AWG: 25 in-lbs  
10-14 AWG: 20 in-lbs

**LUG DETAIL & TORQUE INFO**  
**IlSCO Lay-In Lug (GBL-4DBT)**

- 10-32 mounting hardware
- Torque = 5 ft-lb
- AWG 4-14 - Solid or Stranded

**TERMINAL TORQUE,**  
Install Conductor and torque to the following:  
4-14 AWG: 35in-lbs

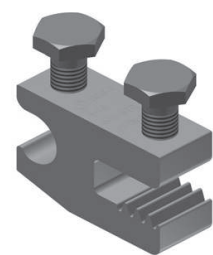

**LUG DETAIL & TORQUE INFO**  
**IlSCO Flange Lug (SGB-4)**

- 1/4" mounting hardware
- Torque = 75 in-lb
- AWG 4-14 - Solid or Stranded

WEEBLUG Single Use Only

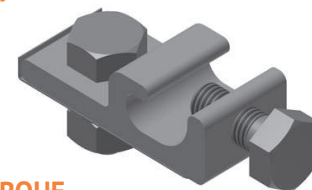

**TERMINAL TORQUE,**  
Install Conductor and torque to the following:  
6-14 AWG: 7ft-lbs

**LUG DETAIL & TORQUE INFO**  
**Wiley WEEBLug (6.7)**

- 1/4" mounting hardware
- Torque = 10 ft-lb
- AWG 6-14 - Solid or Stranded

**NOTE: ISOLATE COPPER FROM ALUMINUM CONTACT TO PREVENT CORROSION**

**System bonding is accomplished through modules. System grounding accomplished by attaching a ground lug to any module at a location on the module specified by the module manufacturer.**

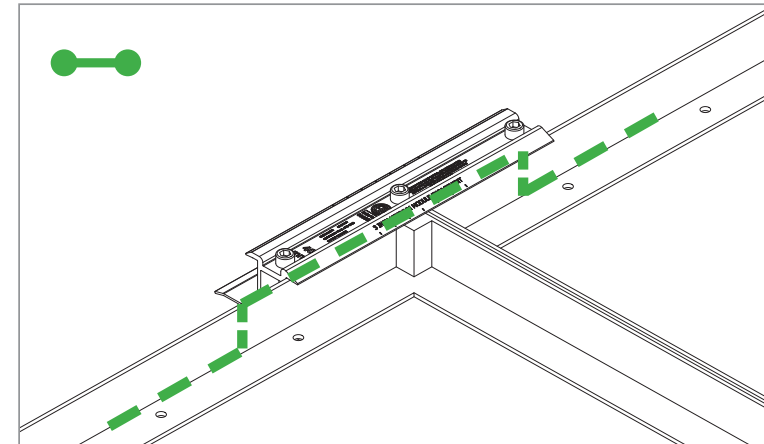

**E-W BONDING PATH:**

E-W module to module bonding is accomplished with 2 pre-installed bonding pins which engage on the secure side of the Microrail™ and splice.

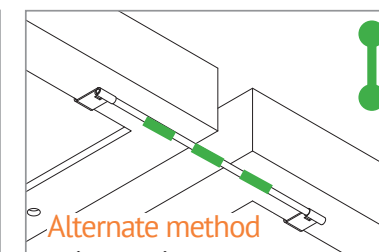
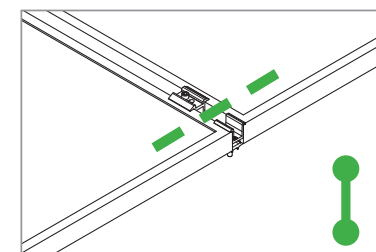

**N-S BONDING PATH:**

N-S module to module bonding is accomplished with bonding clamp with 2 integral bonding pins. (refer also to alternate method)

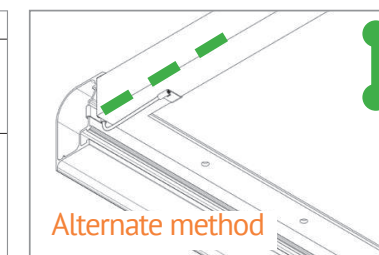
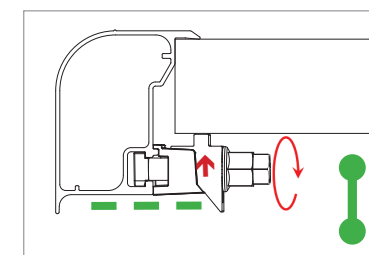

**TRIMRAIL BONDING PATH:**

Trimrail to module bonding is accomplished with bonding clamp with integral bonding pin and bonding T-bolt. (refer also to alternate method)

### SYSTEM LEVEL FIRE CLASSIFICATION

The system fire class rating requires installation in the manner specified in the SUNFRAME MICRORAIL (SFM) Installation Guide. SFM has been classified to the system level fire portion of UL 1703. This UL 1703 classification has been incorporated into the UL 2703 product certification. SFM has achieved Class A, B & C system level performance for low slope & steep sloped roofs when used in conjunction with type 1 and type 2 modules. Class A, B & C system level fire

performance is inherent in the SFM design, and no additional mitigation measures are required. The fire classification rating is valid for any roof pitch. There is no required minimum or maximum height limitation above the roof deck to maintain the Class A, B & C fire rating for SFM. SUNFRAME MICRORAIL™ components shall be mounted over a fire resistant roof covering rated for the application.

Module Type	Roof Slope	System Level Fire Rating	Microrail Direction	Module Orientation	Mitigation Required
Type 1 and Type 2	Steep Slope & Low Slope	Class A, B & C	East-West	Landscape OR Portrait	None Required

### UL2703 TEST MODULES

See pages 22 and 23 for a list of modules that were electrically and mechanically tested or qualified with the SUNFRAME MICRORAIL (SFM) components outlined within this Installation Guide.

- Maximum Area of Module = 27.76 sqft
- UL2703 Design Load Ratings:
  - a) Downward Pressure – 113 PSF / 5400 Pa
  - b) Upward Pressure – 50 PSF / 2400 Pa
  - c) Down-Slope Load – 21.6 PSF / 1034 Pa
- Tested Loads:
  - a) Downward Pressure – 170 PSF / 8000 Pa
  - b) Upward Pressure – 75 PSF / 3500 Pa
  - c) Down-Slope Load – 32.4 PSF / 1550 Pa
- Maximum Span = 6ft
- Use with a maximum over current protection device OCPD of 30A
- System conforms to UL Std 2703, certified to LTR AE-001-2012
- Rated for a design load of 2400 Pa / 5400 Pa with 24 inch span
- PV modules may have a reduced load rating, independent of the SFM load rating. Please consult the PV module manufacturer's installation guide for more information
- Down-Slope design load rating of 30 PSF/ 1400 Pa for module areas of 22.3 sq ft or less

Manufacture	Module Model / Series
Aleo	P-Series
Aptos	DNA-120-(BF/MF)26 DNA-144-(BF/MF)26
Astronergy	CHSM6612P, CHSM6612P/HV, CHSM6612M, CHSM6612M/HV, CHSM6610M (BL)(BF)/(HF), CHSM72M-HC
Auxin	AXN6M610T, AXN6P610T, AXN6M612T & AXN6P612T
Axitec	AXIblackpremium 60 (35mm), AXIpower 60 (35mm), AXIpower 72 (40mm), AXIpremium 60 (35mm), AXIpremium 72 (40mm).
Boviet	BVM6610, BVM6612
BYD	P6K & MHK-36 Series
Canadian Solar	CS1(H/K/U/Y)-MS CS3(K/L/U), CS3K-MB-AG, CS3K-(MS/P) CS3N-MS, CS3U-MB-AG, CS3U-(MS/P), CS3W CS5A-M, CS6(K/U), CS6K-(M/P), CS6K-MS CS6P-(M/P), CS6U-(M/P), CS6V-M, CS6X-P
Centrosolar America	C-Series & E-Series
CertainTeed	CT2xxMxx-01, CT2xxPxx-01, CTxxxMxx-02, CTxxxM-03, CTxxxMxx-04, CTxxxHC11-04
Dehui	DH-60M

Manufacture	Module Model / Series
Eco Solargy	Orion 1000 & Apollo 1000
ET Solar	ET-M672BHxxxTW
Freedom Forever	FF-MP-BBB-370
FreeVolt	Mono PERC
GCL	GCL-P6 & GCL-M6 Series
Hansol	TD-AN3, TD-AN4, UB-AN1, UD-AN1
Heliene	36M, 60M, 60P, 72M & 72P Series, 144HC M6 Monofacial/ Bifacial Series, 144HC M10 SL Bifacial
HT Solar	HT60-156(M) (NDV) (-F), HT 72-156(M/P)
Hyundai	KG, MG, TG, RI, RG, TI, MI, HI & KI Series HiA-SxxxHG
ITEK	iT, iT-HE & iT-SE Series
Japan Solar	JPS-60 & JPS-72 Series
JA Solar	JAP6 60-xxx, JAM6-60-xxx/SI, JAM6(K)-60/ xxx, JAP6(k)-72-xxx/4BB, JAP72SYY-xxx/ZZ, JAP6(k)-60-xxx/4BB, JAP60SYY-xxx/ZZ, JAM6(k)-72-xxx/ZZ, JAM72SYY-xxx/ZZ, JAM6(k)-60-xxx/ZZ, JAM60SYY-xxx/ZZ. i. YY: 01, 02, 03, 09, 10 ii. ZZ: SC, PR, BP, HiT, IB, MW, MR
Jinko	JKM & JKMS Series Eagle JKMxxxM JKMxxxM-72HL-V
Kyocera	KU Series

Manufacture	Module Model / Series		
LG Electronics	LGxxxN2T-A4 LGxxx(A1C/E1C/E1K/N1C/N1K/N2T/N2W/ Q1C/Q1K/S1C/S2W)-A5 LGxxxN2T-B5 LGxxxN1K-B6 LGxxx(A1C/M1C/M1K/N1C/N1K/Q1C/Q1K/ QAC/QAK)-A6 LGxxx(N1C/N1K/N2T/N2W)-E6 LGxxx(N1C/N1K/N2W/S1C/S2W)-G4 LGxxxN2T-J5 LGxxx(N1K/N1W/N2T/N2W)-L5 LGxxx(N1C/Q1C/Q1K)-N5 LGxxx (N1C/N1K/N2W/Q1C/Q1K)-V5		
	LONGi	LR4-60(HIB/HiH/HPB/HPH)-xxxM LR4-72(HiH/HPH)-xxxM LR6-60(BP/HBD/HIBD)-xxxM (30mm) LR6-60(BK)(PE)(HPB)(HPH)-xxxM (35mm) LR6-60(BK)(PE)(PB)(PH)-xxxM (40mm) LR6-72(BP)(HBD)(HIBD)-xxxM (30mm) LR6-72(HV)(BK)(PE)(PH)(PB)(HPH)-xxxM (35mm) LR6-72(BK)(HV)(PE)(PB)(PH)-xxxM (40mm)	
		Mission Solar Energy	MSE Series
		Mitsubishi	MJE & MLE Series
		Neo Solar Power Co.	D6M & D6P Series

- Unless otherwise noted, all modules listed above include all wattages and specific models within that series. Variable wattages are represented as "xxx"
- Items in parenthesis are those that may or may not be present in a compatible module's model ID
- Slashes "/" between one or more items indicates that either of those items may be the one that is present in a module's model ID
- Please see the SFM UL2703 Construction Data Report at Unirac.com to ensure the exact solar module selected is approved for use with SFM
- SFM Infinity is not compatible with module frame height of less than 30mm and more than 40mm. See Module Mounting section, page 12 for further information

Manufacture	Module Model / Series
Panasonic	EVPVxxx (H/K/PK), VBHNxxxSA15 & SA16, VBHNxxxSA17 & SA18, VBHNxxxSA17(E/G) & SA18E, VBHNxxxKA01 & KA03 & KA04, VBHNxxxZA01, VBHNxxxZA02, VBHNxxxZA03, VBHNxxxZA04
Peimar	SGxxxM (FB/BF)
Phono Solar	PS-60, PS-72
Prism Solar	P72 Series
Q.Cells	Plus, Pro, Peak, G3, G4, G5, G6(+), G7, G8(+) Pro, Peak L-G2, L-G4, L-G5, L-G6, L-G7 Q.PEAK DUO BLK-G6+ Q.PEAK DUO BLK-G6+/TS Q.PEAK DUO (BLK)-G8(+) Q.PEAK DUO L-G8.3/BFF Q.PEAK DUO (BLK) ML-G9(+) Q.PEAK DUO XL-G9/G9.2/G9.3 Q.PEAK DUO (BLK) ML-G10(+) Q.PEAK DUO XL-G(10/10.2/10.3/10.c/10.d) Q.PEAK DUO BLK ML-G10+ / t
REC Solar	Alpha (72) (Black) (Pure) RECxxxAA PURE-R RECxxxNP3 Black N-Peak (Black) N-Peak 2 (Black) PEAK Energy Series PEAK Energy BLK2 Series PEAK Energy 72 Series

Manufacture	Module Model / Series
REC Solar (cont.)	TwinPeak Series TwinPeak 2 Series TwinPeak 2 BLK2 Series TwinPeak 2S(M)72(XV) TwinPeak 3 Series (38mm) TP4 (Black)
Renesola	Vitrus2 Series & 156 Series
Risen	RSM72-6 (MDG) (M), RSM60-6
SEG Solar	SEG-xxx-BMD-HV SEG-xxx-BMD-TB
S-Energy	SN72 & SN60 Series (40mm)
Seraphim	SEG-6 & SRP-6 Series
Sharp	NU-SA & NU-SC Series
Silfab	SLA, SLG, BC Series & SILxxx(BL/NL/NT/HL/ML/BK/NX/NU/HC)
Solarever USA	SE-166*83-xxxM-120N
Solaria	PowerXT-xxxR-(AC/PD/BD) PowerXT-xxxC-PD PowerXT-xxxR-PM (AC)
SolarWorld	Sunmodule Protect, Sunmodule Plus
Sonali	SS-M-360 to 390 Series, SS-M-390 to 400 Series, SS-M-440 to 460 Series, SS-M-430 to 460 BiFacial Series, SS 230 - 265
SunEdison	F-Series, R-Series & FLEX FXS Series

Manufacture	Module Model / Series
Suniva	MV Series & Optimus Series
SunPower	A-Series A400-BLK, SPR-MAX3-XXX-R, X-Series, E-Series & P-Series
Suntech	STP, STPXXXS - B60/Wnhb
Talesun	TP572, TP596, TP654, TP660, TP672, Hipor M, Smart
Tesla	SC, SC B, SC B1, SC B2 TxxxH, TxxxS
Trina	PA05, PD05, DD05, DE06, DD06, PE06, PD14, PE14, DD14, DE09.05, DE14, DE15, PE15H
Upsolar	UP-MxxxP(-B), UP-MxxxM(-B)
United Renewable Energy (URE)	D7MxxxH7A, D7(M/K)xxxH8A FAKxxx(C8G/E8G), FAMxxxE7G-BB FAMxxxE8G(-BB) FBMxxxMFG-BB
Vikram	Eldora, Solivo, Somera
Waaree	AC & Adiya Series
Winaico	WST & WSP Series
Yingli	YGE & YLM Series
ZN Shine	ZXM6-72, ZXM6-NH144-166_2094

- Unless otherwise noted, all modules listed above include all wattages and specific models within that series. Variable wattages are represented as "xxx"
- Items in parenthesis are those that may or may not be present in a compatible module's model ID
- Slashes "/" between one or more items indicates that either of those items may be the one that is present in a module's model ID
- Please see the SFM UL2703 Construction Data Report at Unirac.com to ensure the exact solar module selected is approved for use with SFM
- SFM Infinity is not compatible with module frame height of less than 30mm and more than 40mm. See Module Mounting section, page 12 for further information







1.0 Reference and Address		
Report Number	102393982LAX-002	Original 11-Apr-2016 Revised: 5-Oct-2022
Standard(s)	Mounting Systems, Mounting Devices, Clamping/Retention Devices, and Ground Lugs for Use with Flat-Plate Photovoltaic Modules and Panels [UL 2703:2015 Ed.1+R:24Mar2021] PV Module and Panel Racking Mounting System and Accessories [CSA TIL No. A-40:2020]	
Applicant	Unirac, Inc	Manufacturer 2
Address	1411 Broadway Blvd NE Albuquerque, NM 87102	Address
Country	USA	Country
Contact	Klaus Nicolaedis Todd Ganshaw	Contact
Phone	505-462-2190 505-843-1418	Phone
FAX	NA	FAX
Email	klaus.nicolaedis@unirac.com toddg@unirac.com	Email
Manufacturer 3		Manufacturer 4
Address		Address
Country		Country
Contact		Contact
Phone		Phone
FAX		FAX
Email		Email
Manufacturer 5		
Address		
Country		
Contact		
Phone		
FAX		

1.0 Reference and Address		
Report Number	102393982LAX-002	Original 11-Apr-2016 Revised: 5-Oct-2022
Email		

2.0 Product Description	
Product	Photovoltaic Mounting System, Sun Frame Microrail Installation Guide, PUB2022SEP28
Brand name	Unirac
Description	<p>The product covered by this report is the Sun Frame Micro Rail roof mounted Photovoltaic Rack Mounting System. This system is designed to provide bonding and grounding to photovoltaic modules. The mounting system employs anodized or mill finish aluminum brackets that are roof mounted using the slider, outlined in section 4 of this report. There are no rails within this product, whereas the 3" Micro Rail, Floating Splice, and 9" Attached Splice electrically bond the modules together forming the path to ground.</p> <p>The Micro Rails are installed onto the module frame by using a stainless steel bolt anodized with black oxide with a stainless type 300 bonding pin, torqued to 20 ft-lbs, retaining the modules to the bracket. The bonding pin of the Micro Rail when bolted and torqued, penetrate the anodized coating of the photovoltaic module frame (at bottom flange) to contact the metal, creating a bonded connection from module to module.</p> <p>The grounding of the entire system is intended to be in accordance with the latest edition of the National Electrical Code, including NEC 250: Grounding and Bonding, and NEC 690: Solar Photovoltaic Systems or the Canadian Electrical Code, CSA C22.1 Part 1 in accordance to the revision in effect in the jurisdiction in which the project resides. Any local electrical codes must be adhered in addition to the national electrical codes. The Grounding Lug is secured to the photovoltaic module, torqued in accordance with the installation manual provided in this document.</p> <p>Other optional grounding includes the use of the Enphase UL2703 certified grounding system, which requires a minimum of 2 micro-inverters mounted to the same rail, and using the same engage cable.</p>

2.0 Product Description	
Models	Unirac SFM
Model Similarity	NA
Ratings	<p>Fuse Rating: 30A</p> <p>Module Orientation: Portrait or Landscape Maximum Module Size: 17.98 ft<sup>2</sup> UL2703 Design Load Rating: 33 PSF Downward, 33 PSF Upward, 10 PSF Down-Slope Tested Loads - 50 psf/2400Pa Downward, 50psf/2400Pa Uplift, 15psf/720Pa Down Slope Trina TSM-255PD05.08 and Sunpower SPR-E20-327 used for Mechanical Loading</p> <p>Increased size ML test: Maximum Module Size: 22.3 ft<sup>2</sup> UL2703 Design Load Rating: 113 PSF Downward, 50 PSF Upward, 30 PSF Down-Slope LG355S2W-A5 used for Mechanical Loading test. Mounting configuration: Four mountings on each long side of panel with the longest span of 24" UL2703 Design Load Rating: 46.9 PSF Downward, 40 PSF Upward, 10 PSF Down-Slope LG395N2W-A5, LG360S2W-A5 and LG355S2W-A5 used for used for Mechanical Loading test. Mounting configuration: Six mountings for two modules used with the maximum span of 74.5" IEC 61646 Test Loads - 112.78 psf/5400Pa Downward, 50psf/2400Pa Uplift</p> <p>Mechanical Load test to add FlashLoc Slider and Trim Assemblies to UL2703 and IEC 61646 Certifications, &amp; Increase SFM System UL2703 Module Size: Maximum Module Size: 27.76 ft<sup>2</sup> UL2703 Design Load Rating: 113 PSF Downward, 50 PSF Upward, 21.6 PSF Down-Slope Jinko Eagle 72HM G5 used for Mechanical Loading test. Mounting configuration: Four mountings on each long side of panel with the longest span of 24" Maximum module size: 21.86 ft<sup>2</sup> IEC 61646 Test Loads - 112.78 psf/5400Pa Downward, 75psf/3600Pa Uplift SunPower model SPR-A430-COM-MLSD used for Mechanical Loading</p> <p>Fire Class Resistance Rating: - Class A for Steep Slope Applications when using Type 1 Modules. Can be installed at any interstitial gap. Installations must include Trim Rail. - Class A for Steep Slope Applications when using Type 2 Modules. Can be installed at any interstitial gap. Installations must include Trim Rail. - Class A Fire Rated for Low Slope applications with Type 1 or 2 listed photovoltaic modules. This system was evaluated with a 5" gap between the bottom of the module and the roof's surface</p> <p>See section 7.0 illustrations # 1, 1a and 1b for a complete list of PV modules evaluated with these racking systems</p>
Other Ratings	NA

