

© 2024 NC SOLAR NOW EXPRESSLY RESERVES ITS COMMON LAW COPYRIGHT AND OTHER PROPERTY RIGHTS IN THESE PLANS. THESE PLANS ARE NOT TO BE REPRODUCED, CHANGED OR COPIED IN ANY FORM OR MANNER WHATSOEVER, NOR ARE THEY TO BE ASSIGNED TO ANY THIRD PARTY WITHOUT FIRST OBTAINING THE EXPRESSED WRITTEN PERMISSION AND CONSENT OF NC SOLAR NOW.



PV MATERIAL SUMMARY: DISTRIBUTOR	
Q.TRON BLK M-G2+ 425	14
MCI-1	5
MI-BHW	5
Tesla PW3 1707000-xx-y	1
Tesla GW3 1841000-01-y	1
XR-10-168B	8
XR10-BOSS-01-M1	4
UFO-CL-01-B1	32
UFO-STP-30MM-B1	8
XR-LUG-03-A1	2
4 IN QB1	30
GC66803 Geocel Sealant	2
SOLADECK 0799-5B	1



CLIENT INFO
 SUSAN HIGHTOWER
 205 SNEED LANE
 FUQUAY-VARINA, NC 27526

PROJECT INFO
 DC INPUT: 5.950 kW
 AC OUTPUT: 11.500 kW
 DOI INSP. METHOD: OPTION 2

Model Energy
 300 Fayetteville St.
 #1430
 Raleigh, NC 27602
 919-274-9905
 ModelEnergy.com
 P-1194

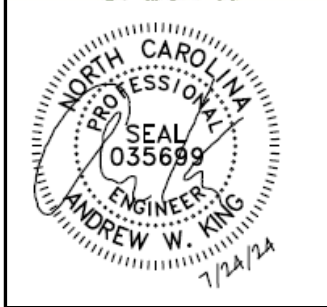

CODE REFERENCES
 NATIONAL ELECTRICAL CODE v. 2017
 NC FIRE PROTECTION CODE v. 2018
 NC BUILDING CODE v. 2018
 NC RESIDENTIAL CODE v. 2018
 ACSE v. 7-10

SITE CONDITIONS
 WIND SPEED: 120 MPH
 RISK CATEGORY: II
 EXPOSURE: B
 SNOW: 15 PSF

SHEET INDEX
 PV-1: COVER SHEET
 PV-2: PV STRUCTURAL
 PV-3: PV ELECTRICAL
 PV-4: PV EQUIPMENT LABELS
 PV-5: PV INSTALL GUIDE

VERSIONS

FOR:	DESIGNER	DATE
CONSTRUCTION	CRM	7/19/2024

PV SYSTEM COVER PAGE

PV-1.1

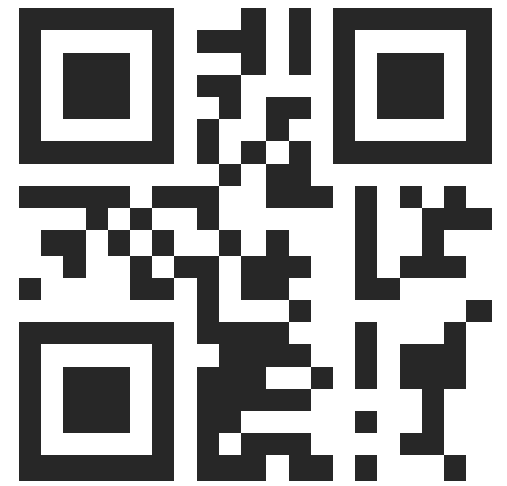

NOTICE TO CONTRACTOR:
 All construction shall comply with current NC Building Codes and is subject to field inspection and verification.

APPROVED
 Licensed Building and Safety Permit Holder responsible for full compliance with the code.
 08/26/2024

© 2024 NC SOLAR NOW EXPRESSLY RESERVES ITS COMMON LAW COPYRIGHT AND OTHER PROPERTY RIGHTS IN THESE PLANS. THESE PLANS ARE NOT TO BE REPRODUCED, CHANGED OR COPIED IN ANY FORM OR MANNER WHATSOEVER, NOR ARE THEY TO BE ASSIGNED TO ANY THIRD PARTY WITHOUT FIRST OBTAINING THE EXPRESSED WRITTEN PERMISSION AND CONSENT OF NC SOLAR NOW.

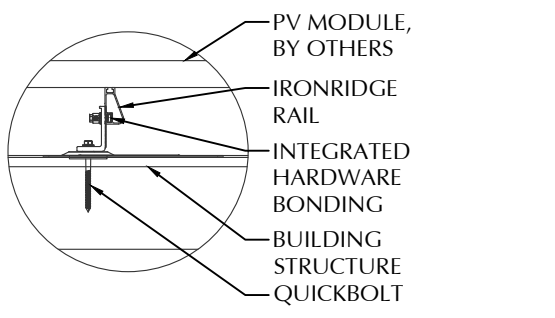
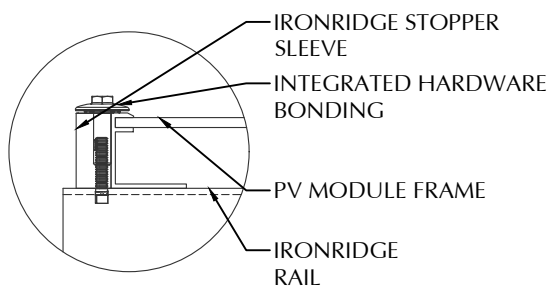
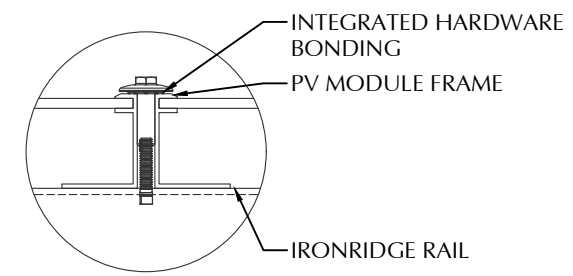
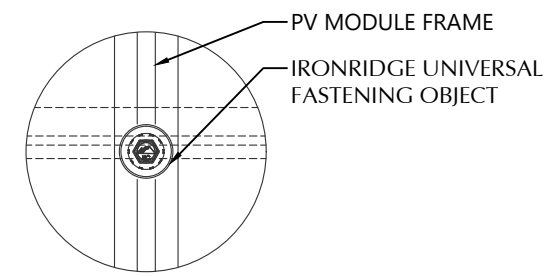
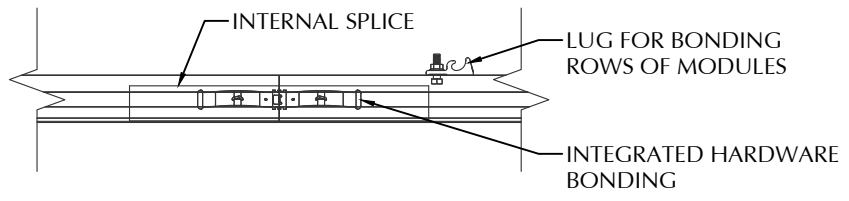
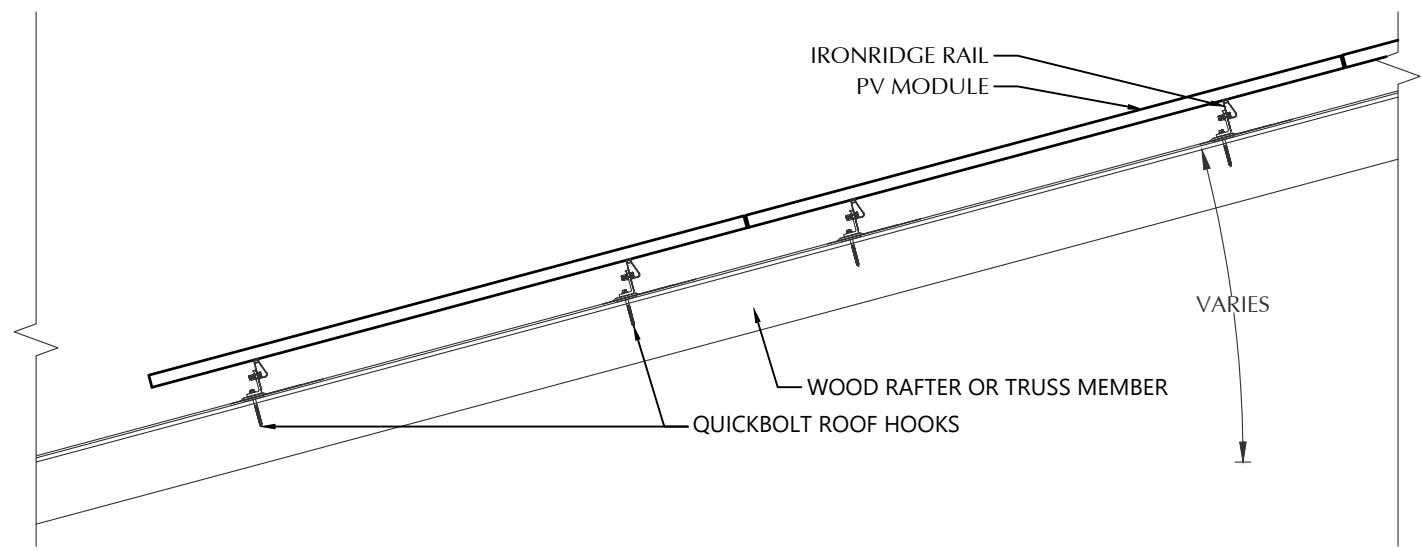

STATEMENT OF STRUCTURAL COMPLIANCE

THE EXISTING ROOF STRUCTURE HAS BEEN DESIGNED TO SUPPORT THE ADDITIONAL LOADS OF THE PROPOSED PV SYSTEM. IN ADDITION, THE RACKING AND FASTENING SYSTEM SHALL BE CAPABLE OF SECURING THE SYSTEM TO THE STRUCTURE UNDER DESIGN CONDITIONS WHEN INSTALLED PROPERLY AND IN ACCORDANCE WITH THE RACKING AND FASTENING ARRANGEMENT DETAILED WITHIN THESE DRAWINGS.

NAME: ANDREW W. KING, PE

SIGNED:

PV MODULES	
MAKE	HANWHA
MODEL	Q.TRON BLK M-G2+ 425
WIDTH	44.60 IN
LENGTH	67.80 IN
THICKNESS	30 MM
WEIGHT	46.70 LBS.
ARRAY AREA	294 SQFT.
ARRAY WEIGHT	735 LBS.

ROOF SUMMARY	
STRUCTURE:	
TYPE	TRUSSES
MATERIAL	SOUTHERN PINE #2
SIZE	2 X 4
SPACING	24 IN O.C.
ALLOWABLE SPAN	88 IN
PITCH	10/12
DENSITY	30 LBS./CU.FT.
DECKING:	
TYPE	OSB
MATERIAL	COMPOSITE
THICKNESS	7/16 IN
WEIGHT	1.60 LBS./SQFT
ROOFING:	
TYPE	ASPHALT SHINGLE
MATERIAL	ASPHALT
WEIGHT	2.30 LBS./SQFT.



CLIENT INFO
 SUSAN HIGHTOWER
 205 SNEED LANE
 FUQUAY-VARINA, NC 27526

PROJECT INFO
 DC INPUT: 5.950 kW
 AC OUTPUT: 11.500 kW
 DOI INSPT. METHOD: OPTION 2

Model Energy
 300 Fayetteville St.
 #1430
 Raleigh, NC 27602
 919-274-9905
 ModelEnergy.com
 P-1194



ROOF MOUNT SUMMARY		
MAXIMUM (IN)	MOUNT SPACING	RAIL OVERHANG
WIND ZONE 1	72 IN	24 IN
WIND ZONE 2	48 IN	24 IN
WIND ZONE 3	48 IN	22 IN

ROOF LOADING	
GROUND SNOW LOAD:	15 LBS./SQFT.
LIVE LOAD	20 LBS./SQFT.
DEAD LOAD	
ROOFING	3.9 LBS./SQFT.
PV ARRAY	2.5 LBS./SQFT.
TOTAL	6.4 LBS./SQFT.
WIND LOAD:	
UPLIFT ZONE 1	-24.6 LBS./SQFT.
UPLIFT ZONE 2	-29.0 LBS./SQFT.
UPLIFT ZONE 3	-29.0 LBS./SQFT.
DOWNWARD	23.0 LBS./SQFT.
FASTENER LOAD:	
UPLIFT ZONE 1	-414 LBS.
UPLIFT ZONE 2	-325 LBS.
UPLIFT ZONE 3	-325 LBS.
DOWNWARD	387 LBS.

CODE REFERENCES
 NATIONAL ELECTRICAL CODE v. 2017
 NC FIRE PROTECTION CODE v. 2018
 NC BUILDING CODE v. 2018
 NC RESIDENTIAL CODE v. 2018
 ACSE v. 7-10

SITE CONDITIONS
 WIND SPEED: 120 MPH
 RISK CATEGORY: II
 EXPOSURE: B
 SNOW: 15 PSF

ROOF MOUNT & FASTENER	
ROOF MOUNT:	
MAKE	QUICKBOLT
MODEL	4 IN QB1
MATERIAL	STAINLESS / EPDM
FASTENER:	
MAKE	QUICK SCREWS
MODEL	HANGER BOLT
MATERIAL	304 SS
SIZE	5/16-18 X 5-1/4"
GENERAL:	
WEIGHT	0.56 LBS.
FASTENERS PER MOUNT	1
MAX. PULL-OUT FORCE	960.0 LBS.
SAFETY FACTOR	2
DESIGN PULL-OUT FORCE	480.0 LBS.

MOUNTING RAILS	
MAKE	IRONRIDGE
MODEL	XR10
MATERIAL	ALUMINUM
WEIGHT	0.425 LBS/IN
SPACING	34 IN

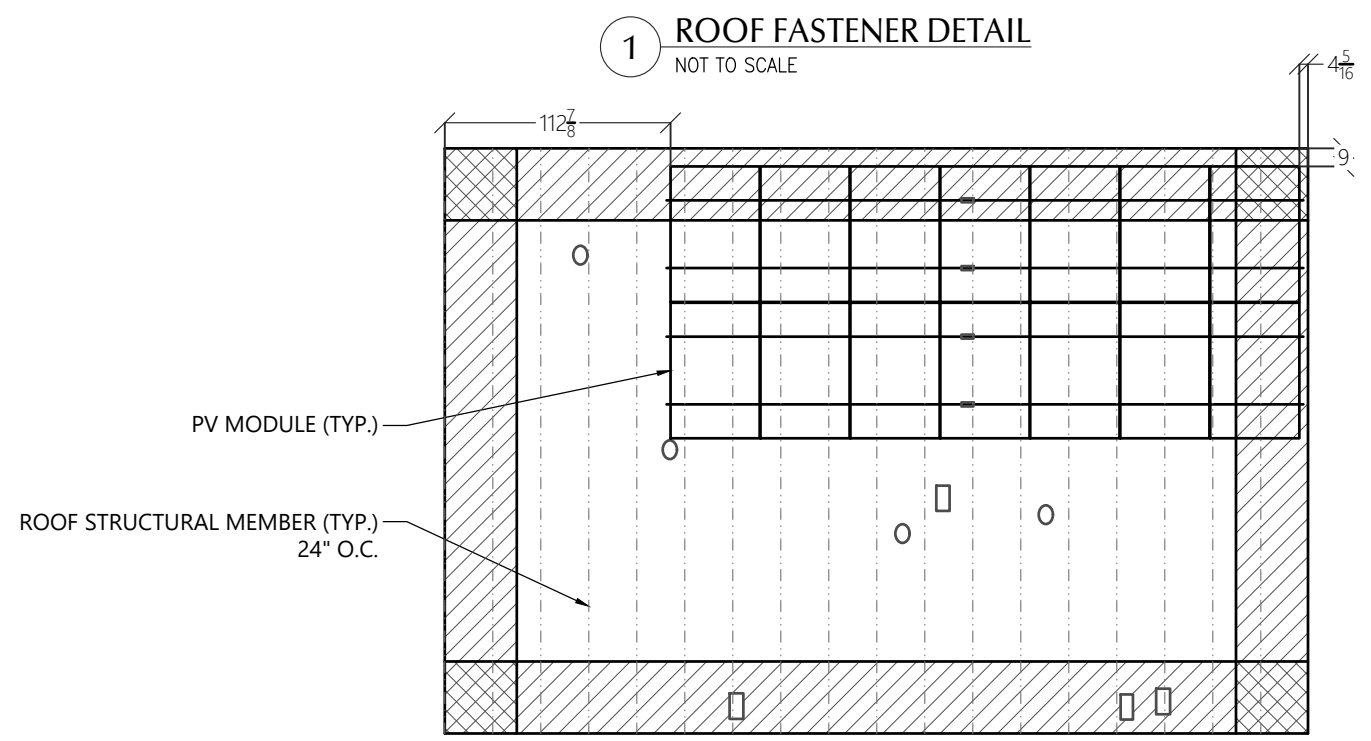

2 ROOF A ARRAY LAYOUT
 1/8" = 1'-0"

1 ROOF FASTENER DETAIL
 NOT TO SCALE

SHEET INDEX
 PV-1: COVER SHEET
 PV-2: PV STRUCTURAL
 PV-3: PV ELECTRICAL
 PV-4: PV EQUIPMENT LABELS
 PV-5: PV INSTALL GUIDE

VERSIONS		
FOR:	DESIGNER	DATE
CONSTRUCTION	CRM	7/19/2024

PV SYSTEM STRUCTURAL

PV-2.1

© 2024 NC SOLAR NOW EXPRESSLY RESERVES ITS COMMON LAW COPYRIGHT AND OTHER PROPERTY RIGHTS IN THESE PLANS. THESE PLANS ARE NOT TO BE REPRODUCED, CHANGED OR COPIED IN ANY FORM OR MANNER WHATSOEVER, NOR ARE THEY TO BE ASSIGNED TO ANY THIRD PARTY WITHOUT FIRST OBTAINING THE EXPRESSED WRITTEN PERMISSION AND CONSENT OF NC SOLAR NOW.



CONDUCTOR SCHEDULE

TAG	CURRENT CARRYING CONDUCTORS			GROUNDING CONDUCTORS			CONDUIT/RACEWAY			NOTES
	QTY.	SIZE	INSULATION	QTY.	SIZE	INSULATION	QTY.	SIZE	LOCATION	
C1	4	10 AWG	PV WIRE	1	6 AWG	BARE	-	-	FREE AIR	1
C2	4	10 AWG	THWN	1	10 AWG	THWN	1	3/4"	EXT/INT	2,4
C3	3	6 AWG	THWN-2	1	10 AWG	THWN-2	1	3/4"	EXTERIOR	2,4
C4	3	4 AWG	THWN-2	1	8 AWG	THWN-2	1	1"	EXT/INT	2,4
XC	-	-	-	-	-	-	-	-	-	3

NOTES:

- MANUFACTURER PROVIDED, UL LISTED WIRING HARNESS FOR USE ON EXPOSED ROOFS
- CONDUIT SIZE SHOWN IS CODE MINIMUM. LARGER SIZES ARE ALLOWED.
- EXISTING CONDUCTORS, FIELD VERIFY
- EQUIPMENT TERMINAL RATING SHALL BE A MINIMUM OF 75°C AT BOTH END OF CONDUCTOR PLEASE REFERENCE NOTES ON PV-4.1 FOR ADDITIONAL DETAIL

MAX. DC VOLTAGE CALCULATION

$V_{oc}MAX = V_{oc} * (1 + (TMIN - TSTC) * (VTC / 100))$	
$V_{oc}MAX$	42.17
MAX STRING VOLTAGE	337.3

MAX. DC CURRENT CALCULATION

$I_{sc}MAX = I_{sc} * TCX$	
$I_{sc}MAX$ (AMPS)	17.13

AC DISCONNECT

MAKE	GENERIC
MODEL	NA
ENCL. RATING	NEMA 3R
VOLT. RATING	240 VOLTS
AMP RATING	60 AMPS
UL LIST. (Y/N)	YES
FUSED (Y/N)	NO
FUSE RATING	N/A

- LOAD-BREAK RATED
- VISIBLE OPEN
- LOCKABLE IN OPEN POSITION
- INSTALL ADJACENT TO METER
- DISCONNECT TO BE READILY ACCESSIBLE TO UTILITY COMPANY PERSONNEL AT ALL TIMES
- DISCONNECT MARKED AND RATED PER NEC SECTION 690.13 AND 705.10

PV MODULE

MAKE	HANWHA
MODEL	Q.TRON BLK M-G2+ 425
NOM. POWER (PNOM)	425 WATTS
NOM. VOLT. (VMPP)	32.7 VOLTS
O.C. VOLT (VOC)	39.0 VOLTS
MAX. SYS. VOLT.	1000 VOLTS
NOM. CURR. (IMPP)	13.0 AMPS
S.C. CURR. (ISC)	13.7 AMPS
TEMP. COEF. (PMPP)	-0.30 %/C
TEMP. COEF. (Voc)	-0.24 %/C
MAX SERIES FUSE	25 AMPS
UL COMPLIANT (Y/N)	YES

ENERGY MANAGEMENT

MAKE	TESLA
MODEL	BACKUP GATEWAY 3
ENCL. RATING	NEMA 3R
VOLT. RATING	240 VOLTS
DISCONNECT CURR.	200 AMPS
UL LIST. (Y/N)	YES
MAIN BREAKER (Y/N)	NO
MAIN BREAKER RATING	N/A

- TROUGH MAY BE USED IF NECESSARY
- CONNECT PW3 VIA 60A BREAKER
- FEED SUB PANEL VIA 90A BREAKER

MID-CIRCUIT INTERRUPTER

MAKE	TESLA
MODEL	MCI-1
ENCL. RATING	NEMA 4X / IP65
DC INPUT:	
MAX POWER	20000 WATTS
INPUT VOLT. RANGE	60-550 VOLTS
MPPT VOLT. RANGE	60-480 VOLTS
MAX. CURR. (Imp / Isc)	13 / 15 AMPS
STRING INPUTS	6 MPPTs
AC OUTPUT:	
MAX. CONT. POWER	11500 WATTS
NOM. VOLT.	120 / 240 VOLTS
MAX. CONT. CURRENT	48.00 AMPS
RAPID SHUTDOWN (Y/N)	YES
PROTECT. RATING	NEMA TYPE 3R
BATTERY INFO:	
USABLE ENERGY	13.5 kWh
NOM. VOLT.	240 VOLTS
MAX. CONT. CHARGE	5000 WATTS
MAX. CONT. DISCHARGE	11500 WATTS
UL LIST. (Y/N)	YES

JUNCTION BOX

MAKE	SOLADECK
MODEL	0799-5B
PROTECT. RATING	NEMA TYPE 3R
UL LIST. (Y/N)	YES

METER COMBO (EXISTING)

MAKE	SIEMENS
MODEL	MC0606L1200R
ENCL. RATING	NEMA 3R
VOLT. RATING	240 VOLTS
BUS RATING	200 AMPS
UL LIST. (Y/N)	YES
MAIN BREAKER (Y/N)	NO
MAIN BREAKER RATING	N/A

- EACH BREAKER SERVES AS SERVICE DISCONNECT
- INTERCEPT SUB PANEL FEED AND REDIRECT TO ENERGY MANAGEMENT

DC/AC INVERTER & BATTERY

MAKE	TESLA POWERWALL 3
MODEL	1707000-XX-Y
DC INPUT:	
MAX POWER	20000 WATTS
INPUT VOLT. RANGE	60-550 VOLTS
MPPT VOLT. RANGE	60-480 VOLTS
MAX. CURR. (Imp / Isc)	13 / 15 AMPS
STRING INPUTS	6 MPPTs
AC OUTPUT:	
MAX. CONT. POWER	11500 WATTS
NOM. VOLT.	120 / 240 VOLTS
MAX. CONT. CURRENT	48.00 AMPS
RAPID SHUTDOWN (Y/N)	YES
PROTECT. RATING	NEMA TYPE 3R
BATTERY INFO:	
USABLE ENERGY	13.5 kWh
NOM. VOLT.	240 VOLTS
MAX. CONT. CHARGE	5000 WATTS
MAX. CONT. DISCHARGE	11500 WATTS
UL LIST. (Y/N)	YES

SUB PANEL (EXISTING)

MAKE	SIEMENS
MODEL	N/A
ENCL. RATING	NEMA 1
VOLT. RATING	240 VOLTS
BUS RATING	225 AMPS
UL LIST. (Y/N)	YES
MAIN BREAKER (Y/N)	NO
MAIN BREAKER RATING	N/A

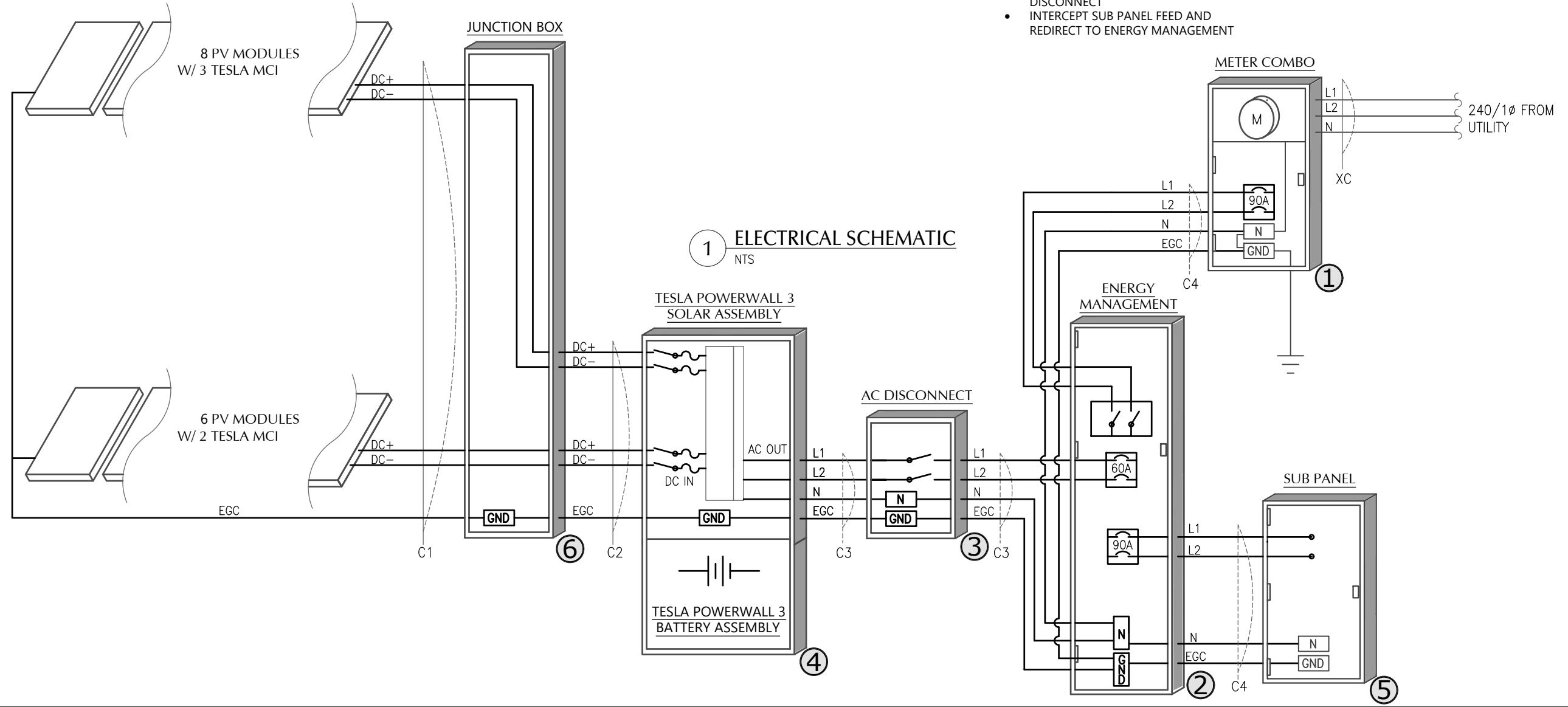

1 ELECTRICAL SCHEMATIC
NTS

CLIENT INFO

SUSAN HIGHTOWER
205 SNEED LANE
FUQUAY-VARINA, NC 27526

PROJECT INFO

DC INPUT: 5.950 kW
AC OUTPUT: 11.500 kW
DOI INSPT. METHOD: OPTION 2

Model Energy

300 Fayetteville St.
#1430
Raleigh, NC 27602
919-274-9905
ModelEnergy.com
P-1194



CODE REFERENCES

NATIONAL ELECTRICAL CODE v. 2017
NC FIRE PROTECTION CODE v. 2018
NC BUILDING CODE v. 2018
NC RESIDENTIAL CODE v. 2018
ACSE v. 7-10

SITE CONDITIONS

WIND SPEED: 120 MPH
RISK CATEGORY: II
EXPOSURE: B
SNOW: 15 PSF

SHEET INDEX

PV-1: COVER SHEET
PV-2: PV STRUCTURAL
PV-3: PV ELECTRICAL
PV-4: PV EQUIPMENT LABELS
PV-5: PV INSTALL GUIDE

VERSIONS

FOR:	DESIGNER:	DATE:
CONSTRUCTION	CRM	7/19/2024

PV SYSTEM ELECTRICAL

PV-3.1

© 2024 NC SOLAR NOW EXPRESSLY RESERVES ITS COMMON LAW COPYRIGHT AND OTHER PROPERTY RIGHTS IN THESE PLANS. THESE PLANS ARE NOT TO BE REPRODUCED, CHANGED OR COPIED IN ANY FORM OR MANNER WHATSOEVER, NOR ARE THEY TO BE ASSIGNED TO ANY THIRD PARTY WITHOUT FIRST OBTAINING THE EXPRESSED WRITTEN PERMISSION AND CONSENT OF NC SOLAR NOW.

DIRECT CURRENT PHOTOVOLTAIC POWER SOURCE

MAXIMUM VOLTAGE 600 VDC
MAX CIRCUIT CURRENT 34.26 AMPS

④ NEC 690.53
PLACE ON ALL DC DISCONNECTING MEANS

WARNING

ELECTRIC SHOCK HAZARD

TERMINALS ON THE LINE AND LOAD SIDES MAY BE ENERGIZED IN THE OPEN POSITION

② NEC 690.13 (B)
PLACE ON PV SYSTEM DISCONNECTING MEANS.

WARNING

THREE POWER SOURCES

SOURCES: UTILITY GRID, BATTERY AND PV SOLAR ELECTRIC SYSTEM

①
②
④
⑤
NEC 705.12 (B)(3)
PLACE ON ALL EQUIPMENT THAT IS SUPPLIED BY BOTH POWER SOURCES

WARNING

THIS EQUIPMENT FED BY MULTIPLE SOURCES. TOTAL RATING OF ALL OVERCURRENT DEVICES EXCLUDING MAIN SUPPLY OVERCURRENT DEVICE SHALL NOT EXCEED AMPACITY OF BUSBAR.

② NEC 705.12 (B)(2)(3)(c)
PLACE ON GATEWAY.

RAPID SHUTDOWN SWITCH FOR SOLAR PV SYSTEM

③ NEC 690.56 (C)(3)
PLACE ON RAPID SHUTDOWN SWITCH OR EQUIPMENT WITH INTEGRATED RAPID SHUTDOWN *REFLECTIVE*

SOLAR PV SYSTEM EQUIPPED WITH RAPID SHUTDOWN

TURN RAPID SHUTDOWN SWITCH TO THE "OFF" POSITION TO SHUT DOWN PV SYSTEM AND REDUCE SHOCK HAZARD IN THE ARRAY

② NEC 690.56 (C)(1)(a)
PLACE WITHIN 3FT OF SERVICE DISCONNECTING MEANS TO WHICH THE PV SYSTEMS ARE CONNECTED AND SHALL INDICATE THE LOCATIONS OF RAPID SHUTDOWN SWITCHES

PV SYSTEM DISCONNECT

③ NEC 690.13 (B)
PLACE ON PV SYSTEM DISCONNECTING MEANS.

WARNING:

IN THE EVENT OF A UTILITY OUTAGE, THIS PANEL IS FED FROM ENERGY STORAGE SYSTEM.

⑤
②

PHOTOVOLTAIC POWER SOURCE

OPERATING AC VOLTAGE 240 V
MAXIMUM OPERATING AC OUTPUT CURRENT 48.00 A

③ NEC 690.54
PLACE ON INTERCONNECTION DISCONNECTING MEANS

WARNING: PHOTOVOLTAIC POWER SOURCE

⑥ NEC 690.31 (G)(3)&(4)
PLACE ON ALL JUNCTION BOXES, EXPOSED RACEWAYS, AND OTHER WIRING METHODS EVERY 10' AND ON EVERY SECTION SEPARATED BY ENCLOSURES, WALLS, PARTITIONS, CEILINGS, OR FLOORS.

SERVICE DISCONNECT LOCATED:
EXTERIOR WEST WALL OF RESIDENCE

BATTERY DISCONNECT LOCATED:
EXTERIOR WEST WALL OF RESIDENCE

PV DISCONNECT LOCATED:
EXTERIOR WEST WALL OF RESIDENCE

① ② ③
NEC 705.10
PLACE AT SERVICE EQUIPMENT AND PV SYSTEM DISCONNECTING MEANS.

LABEL NOTES

1. LABELS SHOWN ARE HALF THEIR ACTUAL REQUIRED SIZE.
2. LABEL MATERIAL SHALL BE SUITABLE FOR THE EQUIPMENT ENVIRONMENT.
3. DC CONDUIT SHALL BE MARKED WITH REQUIRED LABEL EVERY 10 FEET.
4. LABELS WILL BE APPLIED IN ACCORDANCE WITH THE NEC. SOME LABELS MAY NOT BE NECESSARY.

DC WIRING NOTES

1. CONDUCTORS SHALL BE COPPER, RATED AT NOT LESS THAN 600 VOLTS FOR RESIDENTIAL CONSTRUCTION AND NOT LESS THAN 1000 VOLTS FOR COMMERCIAL CONSTRUCTION.
2. MINIMUM SIZE SHALL BE #10 AWG UNLESS OTHERWISE NOTED ON THE DRAWINGS.
3. EXPOSED WIRING CONDUCTOR INSULATION SHALL BE TYPE PV WIRE, USE-2, OR RHW-2 WHERE THE OUTER LAYER OF THE INSULATION IS UV, SUNLIGHT, AND MOISTURE RESISTANT.
6. EXTERIOR WIRING CONDUCTOR INSULATION SHALL BE TYPE THWN-2 AND INSTALLED IN ELECTRICAL METALLIC TUBING(EMT) OR RIGID POLYVINYL CHLORIDE CONDUIT(PVC). ALTERNATIVELY, METAL CLAD CABLE(MC) CAN BE USED AS WELL WHEN RATED FOR USE IN WET LOCATIONS.
7. INTERIOR WIRING CONDUCTOR INSULATION SHALL BE TYPE THHN-2 AND INSTALLED IN ELECTRICAL METALLIC TUBING(EMT), FLEXIBLE METAL CONDUIT(FMC), OR METAL CLAD CABLE(MC).
6. USE SCHEDULE 40 PVC OUTDOORS WHERE NOT SUBJECT TO PHYSICAL DAMAGE OR BELOW FLOOR SLAB. USE SCHEDULE 80 PVC OUTDOORS WHERE SUBJECT TO PHYSICAL DAMMAGE
7. MINIMUM CONDUIT SIZE TO BE 1/2".
8. WIRING METHODS TO CONFORM TO ARTICLES 330, 334, 348, 350, 352, 356, AND 358 OF THE 2017 NEC.

AC WIRING NOTES

1. CONDUCTORS SHALL BE COPPER RATED AT NOT LESS THAN 600 VOLTS.
2. MINIMUM SIZE SHALL BE #14 AWG UNLESS OTHERWISE NOTED ON THE DRAWINGS.
3. EXTERIOR WIRING CONDUCTOR INSULATION SHALL BE TYPE THWN AND INSTALLED IN ELECTRICAL METALLIC TUBING(EMT), RIGID POLYVINYL CHLORIDE CONDUIT(PVC), LIQUID-TIGHT FLEXIBLE METAL CONDUIT(LFMC), OR LIQUID-TIGHT FLEXIBLE NON-METALLIC CONDUIT(LFNC) . ALTERNATIVELY, METAL CLAD CABLE(MC) CAN BE USED AS WELL WHEN RATED FOR USE IN WET LOCATIONS.
4. INTERIOR WIRING CONDUCTOR INSULATION SHALL BE TYPE THHN AND INSTALLED IN ELECTRICAL METALLIC TUBING(EMT), FLEXIBLE METAL CONDUIT(FMC), METAL CLAD CABLE(MC), OR ROMEX.
5. USE SCHEDULE 40 PVC OUTDOORS WHERE NOT SUBJECT TO PHYSICAL DAMAGE OR BELOW FLOOR SLAB. USE SCHEDULE 80 PVC OUTDOORS WHERE SUBJECT TO PHYSICAL DAMMAGE
6. MINIMUM CONDUIT SIZE TO BE 1/2".
7. WIRING METHODS TO CONFORM TO ARTICLES 330, 334, 348, 350, 352, 356, AND 358 OF THE 2017 NEC.

CONSTRUCTION NOTES

1. ALL WORK IS TO BE PERFORMED IN ACCORDANCE WITH THE NEC, STATE, AND LOCAL APPLICABLE CODES.
2. FOLLOW MANUFACTURER'S INSTALLATION INSTRUCTIONS, BEST PRACTICES, AND SPECIFICATIONS.
3. ENSURE REQUIRED MAINTENANCE ACCESS AND CLEARANCES ARE MAINTAINED.
4. WIRES SHALL BE RATED AND LABELED "SUNLIGHT RESISTANT" WHERE EXPOSED TO AMBIENT CONDITIONS.
5. FUSES 0 - 600 AMPS SHALL BE UL CLASS "RK-1" LOW PEAK DUAL ELEMENT TIME DELAY WITH 200,000 AMPERE INTERRUPTING RATING AS MANUFACTURED BY BUSSMANN, UNLESS NOTED OTHERWISE.
6. ALL TERMINALS/LUGS SHALL BE 75° RATED. ALL TERMINALS, SPlicing CONNECTORS, LUGS, ETC SHALL BE IDENTIFIED FOR USE WITH THE MATERIAL (CU/AL) OF THE CONDUCTOR AND SHALL BE PROPERLY INSTALLED.
7. PROVIDE A PULLWIRE IN ALL EMPTY CONDUITS.
8. ALL PENETRATIONS THROUGH EXTERIOR ROOFS SHALL BE FLASHED IN A WATERPROOF MANNER.
9. ALL PENETRATIONS THROUGH ATTIC FIRE BARRIERS SHALL BE SEALED WITH FIRE-BARRIER SEALANT CAULK.
10. SUPPORT ALL CONDUIT AND EQUIPMENT IN ACCORDANCE W/ NEC. ANY SUSPENDED MATERIALS SHALL BE DIRECTLY SUPPORTED BY THE BUILDING STRUCTURE.
11. METAL CONDUIT COUPLINGS CAN BE COMPRESSION TYPE, THREADED, OR BE SET-SCREW TYPE. PLASTIC CONDUIT COUPLINGS TO BE SOCKET GLUED TYPE.
12. A COMPLETE GROUNDING SYSTEM SHALL BE PRESENT OR PROVIDED AND INSTALLED IN ACCORDANCE WITH ARTICLE 250 OF THE NEC, AND AS SHOWN ON THE DRAWINGS.
13. EACH ELECTRICAL APPLIANCE SHALL BE PROVIDED WITH A NAMEPLATE GIVING THE IDENTIFYING NAME AND THE RATING IN VOLTS AND AMPERES, OR VOLTS AND WATTS. IF THE APPLIANCE IS TO BE USED ON A SPECIFIC FREQUENCY OR FREQUENCIES, IT SHALL BE SO MARKED. WHERE MOTOR OVERLOAD PROTECTION EXTERNAL TO THE APPLIANCES IS REQUIRED, THE APPLIANCE SHALL BE SO MARKED.
14. WHERE APPLICABLE, GROUNDING ELECTRODE CONDUCTOR TO BE CONTINUOUS. GROUNDING CRIMPS TO BE IRREVERSIBLE.
15. PHOTOVOLTAIC SYSTEMS SHALL BE PERMANENTLY MARKED AT VARIOUS EQUIPMENT LOCATIONS TO IDENTIFY THAT A PHOTOVOLTAIC SYSTEM IS INSTALLED AND THAT VARIOUS DANGERS ARE PRESENT.
16. EACH PHOTOVOLTAIC SYSTEM DISCONNECTING MEANS SHALL BE PERMANENTLY MARKED TO IDENTIFY IT AS A PHOTOVOLTAIC SYSTEM DISCONNECT.
17. WHERE ALL TERMINALS OF A DISCONNECTING MEANS MAY BE ENERGIZED IN THE OPEN POSITION, A WARNING SIGN SHALL BE MOUNTED ON OR ADJACENT TO THE DISCONNECT.
18. A PERMANENT LABEL FOR THE DIRECT-CURRENT PHOTOVOLTAIC POWER SOURCE SHALL BE PROVIDED AT THE DC DISCONNECT MEANS.
19. A PERMANENT PLAQUE OR DIRECTORY, DENOTING ALL ELECTRIC POWER SOURCES SERVING THE PREMISES, SHALL BE INSTALLED AT EACH SERVICE EQUIPMENT LOCATION AND AT LOCATIONS OF ALL POWER PRODUCTION SOURCES.
20. ALL MODULE GROUND CONNECTIONS SHALL BE MADE IN ACCORDANCE WITH NEC SECTION 690.4 (C).
21. A NORTH CAROLINA REGISTERED DESIGN PROFESSIONAL WILL BE REQUIRED TO SEAL THE STRUCTURAL DESIGN AT THE TIME OF PERMIT APPLICATION IF ANY OF THE FOLLOWING EXIST AND ARE ATTESTED TO BY THE APPLICANT:
 - I. THE WEIGHT OF THE PV SYSTEM EXCEEDS THREE (3) POUNDS PER SQUARE FOOT(PSF)
 - II. THE ROOF POSSESSES MORE THAN ONE (1) LAYER OF ASPHALT SHINGLES
 - III. THE ROOFING MATERIAL CONSISTS OF A TYPE OTHER THAN ASPHALT SHINGLES OR METAL
 - IV. THE ROOF IS LOCATED IN A 140 MPH OR GREATER WIND ZONE



CLIENT INFO

SUSAN HIGHTOWER
205 SNEED LANE
FUQUAY-VARINA, NC 27526

PROJECT INFO

DC INPUT: 5.950 kW
AC OUTPUT: 11.500 kW
DOI INSP. METHOD: OPTION 2

Model Energy

300 Fayetteville St.
#1430
Raleigh, NC 27602
919-274-9905
ModelEnergy.com
P-1194



CODE REFERENCES

NATIONAL ELECTRICAL CODE v. 2017
NC FIRE PROTECTION CODE v. 2018
NC BUILDING CODE v. 2018
NC RESIDENTIAL CODE v. 2018
ACSE v. 7-10

SITE CONDITIONS

WIND SPEED: 120 MPH
RISK CATEGORY: II
EXPOSURE: B
SNOW: 15 PSF

SHEET INDEX

PV-1: COVER SHEET
PV-2: PV STRUCTURAL
PV-3: PV ELECTRICAL
PV-4: PV EQUIPMENT LABELS
PV-5: PV INSTALL GUIDE

VERSIONS

FOR:	DESIGNER	DATE
CONSTRUCTION	CRM	7/19/2024

PV SYSTEM EQUIPMENT LABELS

PV-4.1

© 2024 NC SOLAR NOW EXPRESSLY RESERVES ITS COMMON LAW COPYRIGHT AND OTHER PROPERTY RIGHTS IN THESE PLANS. THESE PLANS ARE NOT TO BE REPRODUCED, CHANGED OR COPIED IN ANY FORM OR MANNER WHATSOEVER, NOR ARE THEY TO BE ASSIGNED TO ANY THIRD PARTY WITHOUT FIRST OBTAINING THE EXPRESSED WRITTEN PERMISSION AND CONSENT OF NC SOLAR NOW.

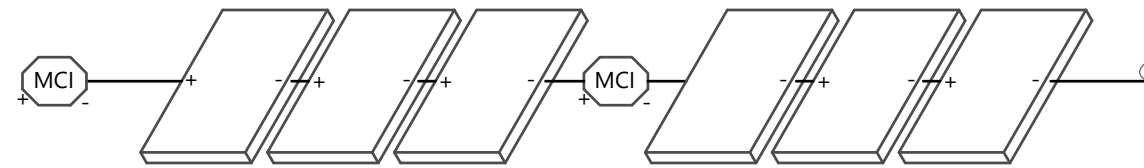

1 STRING WIRING + MCI DETAIL
NOT TO SCALE

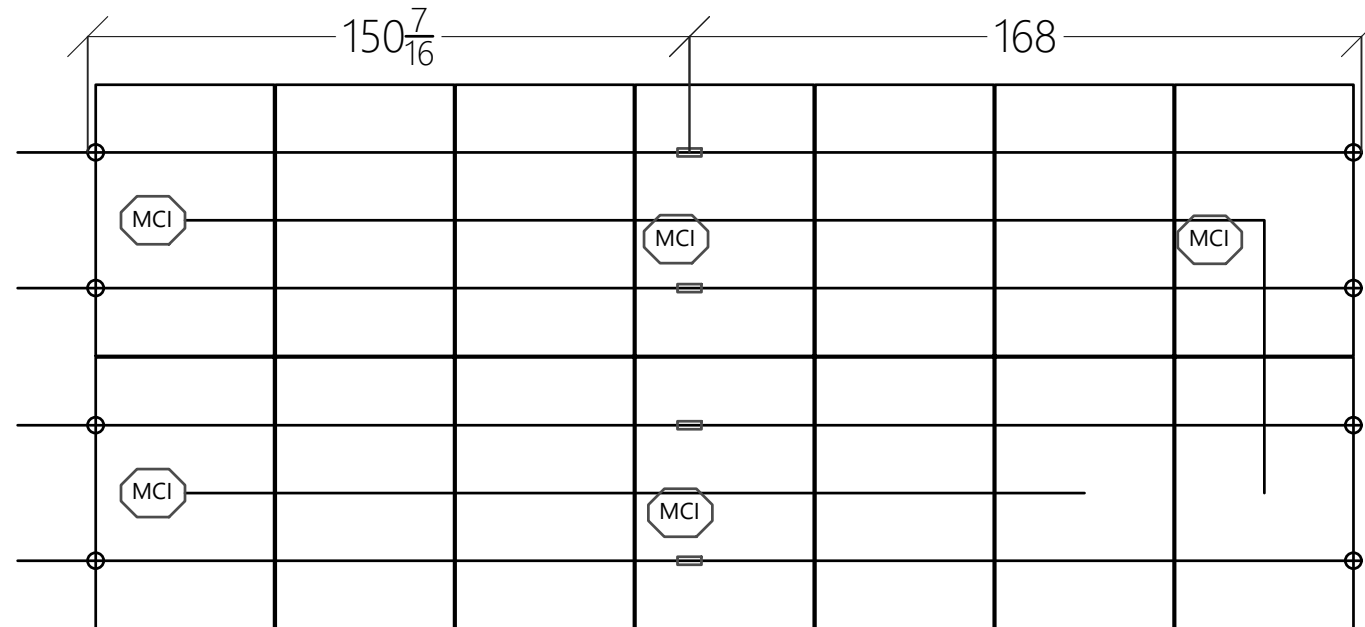

1 ARRAY LAYOUT DETAIL
NOT TO SCALE



CLIENT INFO

SUSAN HIGHTOWER
205 SNEED LANE
FUQUAY-VARINA, NC 27526

PROJECT INFO

DC INPUT: 5.950 kW
AC OUTPUT: 11.500 kW
DOI INSPT. METHOD: OPTION 2

Model Energy

300 Fayetteville St.
#1430
Raleigh, NC 27602
919-274-9905
ModelEnergy.com

P-1194



CODE REFERENCES

NATIONAL ELECTRICAL CODE v. 2017
NC FIRE PROTECTION CODE v. 2018
NC BUILDING CODE v. 2018
NC RESIDENTIAL CODE v. 2018
ACSE v. 7-10

SITE CONDITIONS

WIND SPEED: 120 MPH
RISK CATEGORY: II
EXPOSURE: B
SNOW: 15 PSF

SHEET INDEX

PV-1: COVER SHEET
PV-2: PV STRUCTURAL
PV-3: PV ELECTRICAL
PV-4: PV EQUIPMENT LABELS
PV-5: PV INSTALL GUIDE

VERSIONS

FOR:	DESIGNER	DATE
CONSTRUCTION	CRM	7/19/2024

PV SYSTEM INSTALL GUIDE

PV-5.1

Q.TRON BLK M-G2+ SERIES



PRELIMINARY

410 - 430 Wp | 108 Cells
22.4% Maximum Module Efficiency

MODEL Q.TRON BLK M-G2+



High performance Qcells N-type solar cells

Q.ANTUM NEO Technology with optimized module layout boosts module efficiency up to 22.4%.



A reliable investment

Inclusive 25-year product warranty and 25-year linear performance warranty¹.



Enduring high performance

Long-term yield security with Anti LeTID Technology, Anti PID Technology², Hot-Spot Protect.



Extreme weather rating

High-tech aluminium alloy frame, certified for high snow (5400 Pa) and wind loads (3600 Pa).



Innovative all-weather technology

Optimal yields, whatever the weather with excellent low-light and temperature behaviour.



The most thorough testing programme in the industry

Qcells is the first solar module manufacturer to pass the most comprehensive quality programme in the industry: The new "Quality Controlled PV" of the independent certification institute TÜV Rheinland.

¹ See data sheet on rear for further information.

² APT test conditions according to IEC/TS 62804-1:2015, method A (-1500 V, 96 h)

The ideal solution for:



Rooftop arrays on residential buildings



Q.TRON BLK M-G2+ SERIES

Mechanical Specification

Format	67.8 in × 44.6 in × 1.18 in (including frame) (1722 mm × 1134 mm × 30 mm)
Weight	47.2 lbs (21.4 kg)
Front Cover	0.13 in (3.2 mm) thermally pre-stressed glass with anti-reflection technology
Back Cover	Composite film
Frame	Black anodised aluminium
Cell	6 × 18 monocrystalline Q.ANTUM NEO solar half cells
Junction box	2.09-3.98 in × 1.26-2.36 in × 0.59-0.71 in (53-101 mm × 32-60 mm × 15-18 mm), Protection class IP67, with bypass diodes
Cable	4 mm ² Solar cable; (+) ≥ 59.4 in (1510 mm), (-) ≥ 59.4 in (1510 mm)
Connector	Stäubli MC4; IP68

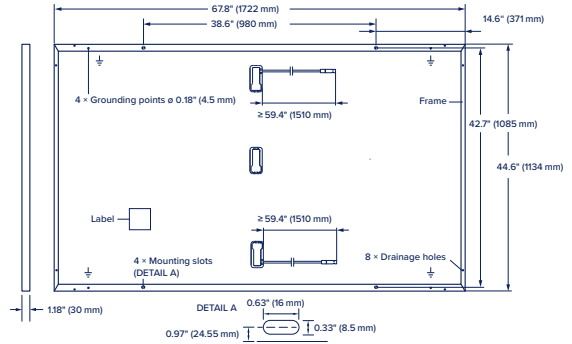

Electrical Characteristics

POWER CLASS			410	415	420	425	430
MINIMUM PERFORMANCE AT STANDARD TEST CONDITIONS, STC ¹ (POWER TOLERANCE +5W/-0W)							
Minimum	Power at MPP ¹	P_{MPP} [W]	410	415	420	425	430
	Short Circuit Current ¹	I_{SC} [A]	13.39	13.42	13.46	13.49	13.53
	Open Circuit Voltage ¹	V_{OC} [V]	38.58	38.61	38.64	38.67	38.70
	Current at MPP	I_{MPP} [A]	12.68	12.75	12.82	12.88	12.95
	Voltage at MPP	V_{MPP} [V]	32.32	32.55	32.77	32.98	33.20
	Efficiency ¹	η [%]	≥ 21.4	≥ 21.6	≥ 21.9	≥ 22.2	≥ 22.4
MINIMUM PERFORMANCE AT NORMAL OPERATING CONDITIONS, NMOT ²							
Minimum	Power at MPP	P_{MPP} [W]	310.0	313.8	317.6	321.4	325.2
	Short Circuit Current	I_{SC} [A]	10.79	10.82	10.84	10.87	10.90
	Open Circuit Voltage	V_{OC} [V]	36.61	36.63	36.66	36.69	36.71
	Current at MPP	I_{MPP} [A]	9.97	10.03	10.09	10.15	10.21
	Voltage at MPP	V_{MPP} [V]	31.09	31.29	31.48	31.66	31.85

¹Measurement tolerances $P_{MPP} \pm 3\%$; I_{SC} ; $V_{OC} \pm 5\%$ at STC: 1000 W/m², 25 ± 2°C, AM 1.5 according to IEC 60904-3 • ²800 W/m², NMOT, spectrum AM 1.5

Qcells PERFORMANCE WARRANTY

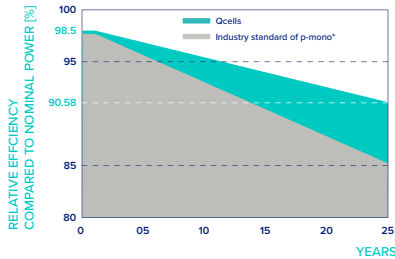

At least 98.5% of nominal power during first year. Thereafter max. 0.33% degradation per year. At least 95.53% of nominal power up to 10 years. At least 90.58% of nominal power up to 25 years.

All data within measurement tolerances. Full warranties in accordance with the warranty terms of the Qcells sales organisation of your respective country.

*Standard terms of guarantee for the 5 PV companies with the highest production capacity in 2021 (February 2021)

PERFORMANCE AT LOW IRRADIANCE

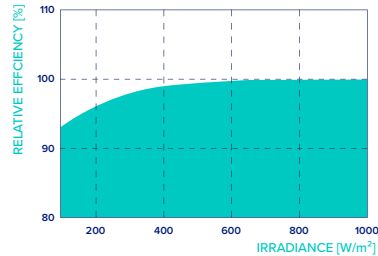

Typical module performance under low irradiance conditions in comparison to STC conditions (25°C, 1000 W/m²).

TEMPERATURE COEFFICIENTS

Temperature Coefficient of I_{SC}	α [%/K]	+0.04	Temperature Coefficient of V_{OC}	β [%/K]	-0.24
Temperature Coefficient of P_{MPP}	γ [%/K]	-0.30	Nominal Module Operating Temperature	NMOT [°F]	109 ± 5.4 (43 ± 3°C)

Properties for System Design

Maximum System Voltage	V_{SYS} [V]	1000 (IEC)/1000 (UL)	PV module classification	Class II
Maximum Series Fuse Rating	[A DC]	20	Fire Rating based on ANSI/UL 61730	C / TYPE 2
Max. Design Load, Push/Pull ³	[lbs/ft ²]	75 (3600 Pa)/50 (2400 Pa)	Permitted Module Temperature on Continuous Duty	-40°F up to +185°F (-40°C up to +85°C)
Max. Test Load, Push/Pull ³	[lbs/ft ²]	113 (5400 Pa)/75 (3600 Pa)		

³ See Installation Manual

Qualifications and Certificates

Quality Controlled PV - TÜV Rheinland; IEC 61215:2016; IEC 61730:2016. This data sheet complies with DIN EN 50380.



Qcells pursues minimizing paper output in consideration of the global environment.

Note: Installation instructions must be followed. Contact our technical service for further information on approved installation of this product.

Hanwha Q CELLS America Inc. 400 Spectrum Center Drive, Suite 1400, Irvine, CA 92618, USA | TEL +1 949 748 59 96 | EMAIL hqc-inquiry@qcells.com | WEB www.qcells.com

qcells

Powerwall 3

Power Everything

—
Powerwall 3 is a fully integrated solar and battery system, designed to accelerate the transition to sustainable energy. Customers can receive whole home backup, cost savings, and energy independence by producing and consuming their own energy while participating in grid services. Once installed, customers can manage their system using the Tesla App to customize system behavior to meet their energy goals.

Powerwall 3 achieves this by supporting up to 20 kW DC of solar and providing 11.5 kW AC of continuous power per unit. It has the ability to start heavy loads up to 150 A LRA, meaning a single unit can support the power needs of most homes. Powerwall 3 is designed for mass production, fast and efficient installations, easy system expansion, and simple connection to any electrical service.



Powerwall 3 Technical Specifications

System Technical Specifications

Model Number	1707000-xx-y
Nominal Grid Voltage (Input & Output)	120/240 VAC
Grid Type	Split phase
Frequency	60 Hz
Overcurrent Protection Device	Configurable up to 60 A
Solar to Battery to Grid Round Trip Efficiency	89% ^{1,2}
Solar to Grid Efficiency	97% ³
Supported Islanding Devices	Backup Gateway 2, Backup Switch
Connectivity	Wi-Fi (2.4 and 5 GHz), Dual-port switched Ethernet, Cellular (LTE/4G ⁴)
Hardware Interface	Dry contact relay, Rapid Shutdown (RSD) certified switch and 2-pin connector, RS-485 for meters
AC Metering	Revenue Grade (+/- 0.5%)
Protections	Integrated arc fault circuit interrupter (AFCI), Isolation Monitor Interrupter (IMI), PV Rapid Shutdown (RSD) using Tesla Mid-Circuit Interrupters
Customer Interface	Tesla Mobile App
Warranty	10 years

Solar Technical Specifications

Maximum Solar STC Input	20 kW
Withstand Voltage	600 V DC
PV DC Input Voltage Range	60 – 550 V DC
PV DC MPPT Voltage Range	150 – 480 V DC
MPPTs	6
Maximum Current per MPPT (I_{mp})	13 A ⁵
Maximum Short Circuit Current per MPPT (I_{sc})	15 A ⁵

Battery Technical Specifications

Nominal Battery Energy	13.5 kWh AC ²
Maximum Continuous Discharge Power	11.5 kW AC
Maximum Continuous Charge Power	5 kW AC
Output Power Factor Rating	0 - 1 (Grid Code configurable)
Maximum Continuous Current	48 A
Maximum Output Fault Current	10 kA
Load Start Capability (1 s)	150 A LRA
Power Scalability	Up to 4 Powerwall 3 units supported

¹ Typical solar shifting use case.

² Values provided for 25°C (77°F), at beginning of life. 3.3 kW charge/discharge power.

³ Tested using CEC weighted efficiency methodology.

⁴ Cellular connectivity subject to network service coverage and signal strength.

⁵ Where the DC input current exceeds the MPPT rating, a jumper can be used to combine two MPPTs into a single input to intake DC current up to 26 A I_{mp} / 30 A I_{sc} .

Powerwall 3 Technical Specifications

Environmental Specifications

Operating Temperature	-20°C to 50°C (-4°F to 122°F) ⁶
Operating Humidity (RH)	Up to 100%, condensing
Storage Temperature	-20°C to 30°C (-4°F to 86°F), up to 95% RH, non-condensing, State of Energy (SOE): 25% initial
Maximum Elevation	3000 m (9843 ft)
Environment	Indoor and outdoor rated
Enclosure Rating	NEMA 3R
Ingress Rating	IPX7 (Battery & Power Electronics) IPX5 (Wiring Compartment)
Pollution Rating	PD3
Operating Noise @ 1 m	< 50 db(A) typical < 62 db(A) maximum

⁶ Performance may be de-rated at operating temperatures above 40°C (104°F).

Compliance Information

Certifications	UL 1642, UL 1699B, UL 1741, UL 1741 SA, UL 1741 SB, UL 3741, UL 1973, UL 1998, UL 9540, IEEE 1547-2018, IEEE 1547.1, UN 38.3
Grid Connection	United States
Emissions	FCC Part 15 Class B
Environmental	RoHS Directive 2011/65/EU
Seismic	AC156, IEEE 693-2005 (high)
Fire Testing	Meets the unit level performance criteria of UL 9540A

Mechanical Specifications

Dimensions	1099 x 609 x 193 mm (43.25 x 24 x 7.6 in)
Weight	130 kg (287 lb)
Mounting Options	Floor or wall mount

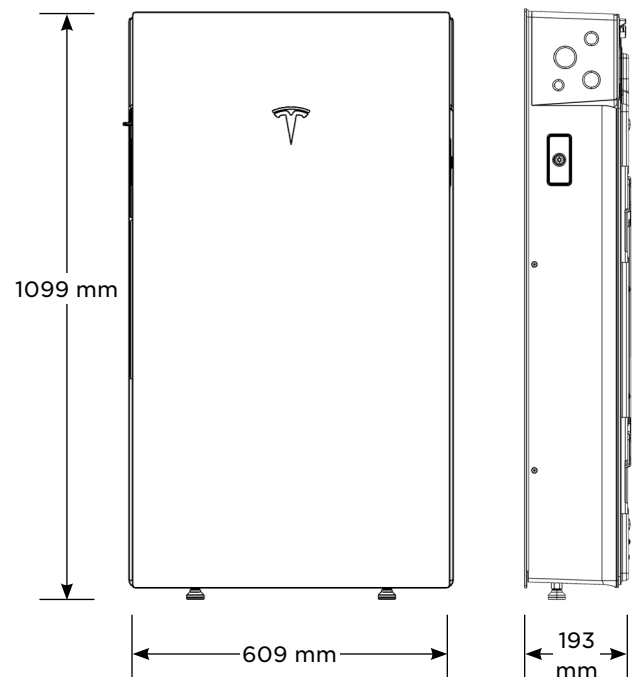

Solar Shutdown Device Technical Specifications

The Solar Shutdown Device is a Mid-Circuit Interrupter (MCI) and is part of the PV system rapid shutdown (RSD) function in accordance with Article 690 of the applicable NEC. When paired with Powerwall 3, solar array shutdown is initiated by any loss of AC power.

Electrical Specifications	Model	MCI-1	MCI-2
	Nominal Input DC Current Rating (I_{MP})	12 A	13 A
	Maximum Input Short Circuit Current (I_{SC})	19 A	17 A
	Maximum System Voltage (PVHCS)	600 V DC	1000 V DC ⁷
⁷ Maximum System Voltage is limited by Powerwall to 600 V DC.			
RSD Module Performance	Maximum Number of Devices per String	5	5
	Control	Power Line Excitation	Power Line Excitation
	Passive State	Normally Open	Normally Open
	Maximum Power Consumption	7 W	7 W
	Warranty	25 years	25 years
Environmental Specifications	Operating Temperature	-40°C to 50°C (-40°F to 122°F)	-45°C to 70°C (-49°F to 158°F)
	Storage Temperature	-30°C to 70°C (-22°F to 158°F)	-30°C to 70°C (-22°F to 158°F)
	Enclosure Rating	NEMA 4X / IP65	NEMA 4X / IP65
Mechanical Specifications	Electrical Connections	MC4 Connector	MC4 Connector
	Housing	Plastic	Plastic
	Dimensions	125 x 150 x 22 mm (5 x 6 x 1 in)	173 x 45 x 22 mm (6.8 x 1.8 x 1 in)
	Weight	350 g (0.77 lb)	120 g (0.26 lb)
	Mounting Options	ZEP Home Run Clip M4 Screw (#10) M8 Bolt (5/16") Nail / Wood screw	Wire Clip
Compliance Information	Certifications	UL 1741 PVRSE, UL 3741, PVRSA (Photovoltaic Rapid Shutdown Array)	
	RSD Initiation Method	External System Shutdown Switch or Powerwall 3 Enable Switch	

UL 3741 PV Hazard Control (and PVRSA) Compatibility

The following categories of solar module meet the UL 3741 PVHCS listing when installed with Powerwall 3 and Solar Shutdown Devices.

Tesla Solar Roof	PV Hazard Control System: BIPV compliance document
Tesla or Hanwha (Q.Peak Duo BLK or BLK-G6+) Modules certified for use with ZEP racking	PV Hazard Control System: ZS PVHCS compliance document
Other module and racking combinations	PV Hazard Control System: Generic PV Array compliance document

Backup Gateway 2

Backup Gateway 2 controls connection to the grid when paired with Powerwall 3, automatically detecting outages and providing seamless transition to backup power. Backup Gateway 2 also provides energy metering for solar self-consumption, time-based control, and backup operation.

In this system configuration, Powerwall 3 acts as the Site Controller, with the Backup Gateway 2 Site Controller disabled.

Performance Specifications

Model Number	1232100-xx-y
AC Voltage (Nominal)	120/240 V
Feed-in Type	Split phase
Grid Frequency	60 Hz
Current Rating	200 A
Maximum Supply Short Circuit Current	10 kA ⁸
Overcurrent Protection Device	100 - 200 A, Service entrance rated ⁸
Overvoltage Category	Category IV
Internal Primary AC Meter	Revenue accurate (+/- 0.2%)
Internal Auxiliary AC Meter	Revenue accurate (+/- 2%)
Primary Connectivity	Ethernet, Wi-Fi
Secondary Connectivity	Cellular (3G, LTE/4G) ⁹

User Interface	Tesla App
Operating Modes	Support for solar self-consumption, time-based control, and backup
Backup Transition	Automatic disconnect for seamless backup
Modularity	Supports up to 10 AC-coupled Powerwalls
Optional Internal Panelboard	200 A 6-space / 12 circuit breakers Siemens QP or Square D HOM breakers rated 10 - 80A or Eaton BR breakers rated 10 - 125A
Warranty	10 years

⁸ When protected by Class J fuses, Backup Gateway 2 is suitable for use in circuits capable of delivering not more than 22kA symmetrical amperes.

⁹ The customer is expected to provide internet connectivity for Backup Gateway 2; cellular should not be used as the primary mode of connectivity. Cellular connectivity subject to network operator service coverage and signal strength.

Environmental Specifications

Operating Temperature	-20°C to 50°C (-4°F to 122°F)
Operating Humidity (RH)	Up to 100%, condensing
Maximum Elevation	3000 m (9843 ft)
Environment	Indoor and outdoor rated
Enclosure Type	NEMA 3R

Compliance Information

Certifications	UL 67, UL 869A, UL 916, UL 1741 PCS, CSA 22.2 0.19, CSA 22.2 205
Emmissions	FCC Part 15, ICES 003

Mechanical Specifications

Dimensions	660 x 411 x 149 mm (26 x 16 x 6 in)
Weight	20.4 kg (45 lb)
Mounting options	Wall mount, Semi-flush mount

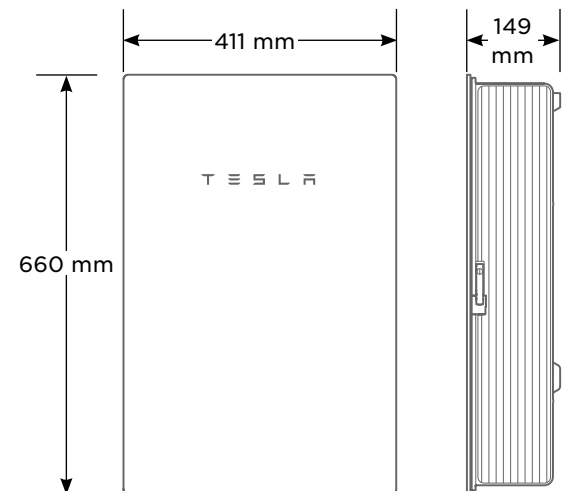

Backup Switch

The Tesla Backup Switch controls connection to the grid in a Powerwall system, and can be easily installed behind the utility meter or in a standalone meter panel downstream of the utility meter.

The Backup Switch automatically detects grid outages, providing a seamless transition to backup power. It communicates directly with Powerwall, allowing home energy usage monitoring from any mobile device with the Tesla app.

Performance Specifications

Model Number	1624171-xx-y
Continuous Load Rating	200 A, 120/240 V split phase
Maximum Supply Short Circuit Current	22 kA with breaker ¹⁰
Communication	CAN
AC Meter	Revenue accurate (+/- 0.5%)
Expected Service Life	21 years
Warranty	10 years

¹⁰ Breaker maximum supply short circuit current rating must be equal to or greater than the available fault current.

Environmental Specifications

Operating Temperature	-40°C to 50°C (-40°F to 122°F)
Storage Temperature	-40°C to 85°C (-40°F to 185°F)
Enclosure Rating	NEMA 3R
Pollution Rating	PD3

Compliance Information

Safety Standards	USA: UL 414, UL 2735, UL 916, CA Prop 65
Emmissions	FCC, ICES

Mechanical Specifications

Dimensions	176 x 205 x 74 mm (6.9 x 8.1 x 2.9 in)
Weight	2.8 lb
Meter and Socket Compatibility	ANSI Type 2S, ringless or ring type
External Service Interface	Contactor manual override ¹¹ Reset button
Conduit Compatibility	1/2-inch NPT

¹¹ Manually overrides the contactor position during a service event.

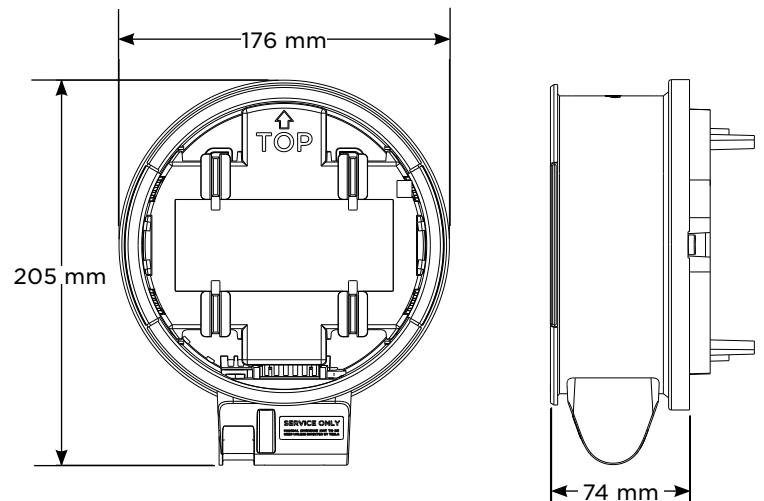

Powerwall 3 Example System Configurations

Powerwall 3 with Backup Switch

Whole Home Backup

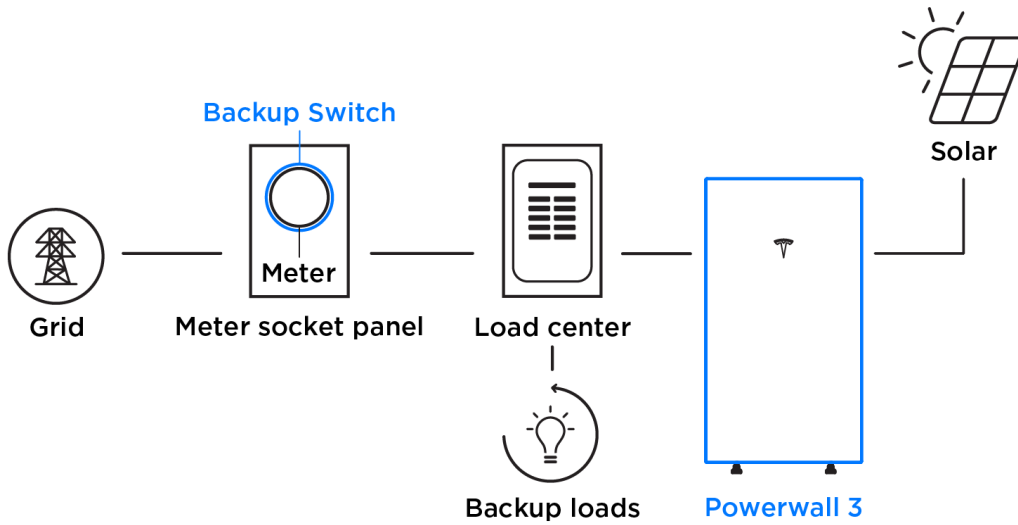

Powerwall 3 with Backup Gateway 2

Partial Home Backup

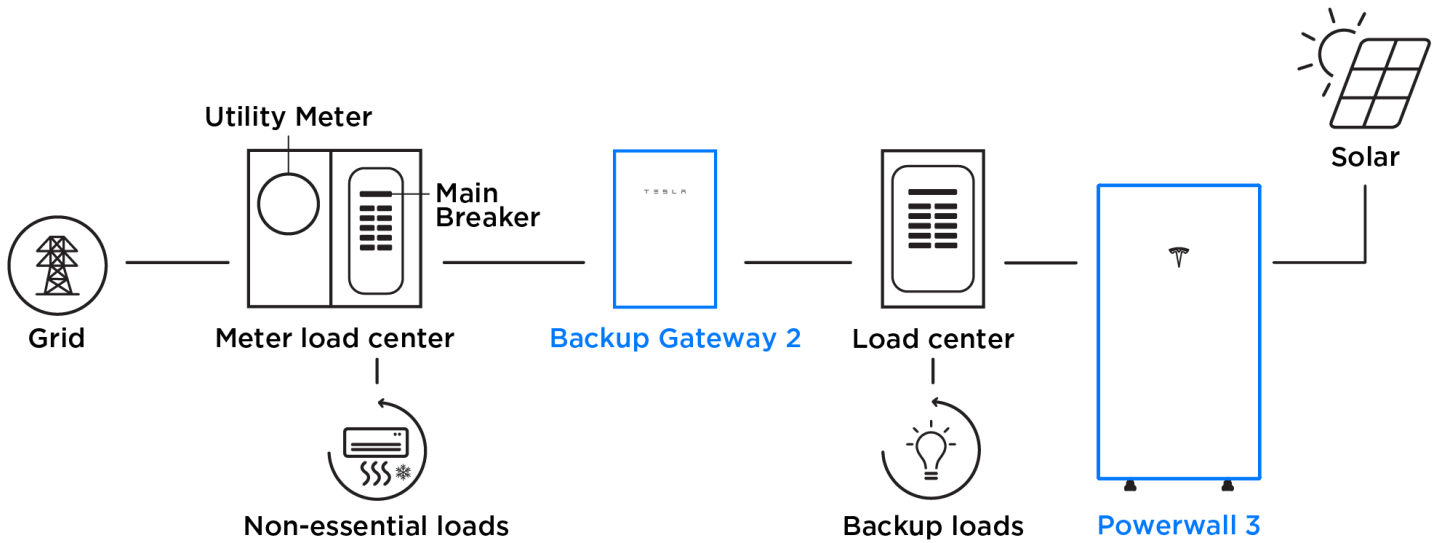

RSTC Enterprises, Inc.
2214 Heimstead Road
Eau Claire, WI 54703
715-830-9997



Outdoor Photovoltaic Enclosures

Composition/Cedar Roof System

ETL listed and labeled

Report # 3171411PRT-002 Revised May, 2018

- UL50 Type 3R, 11 Edition Electrical equipment enclosures
- CSA C22.2 No. 290 Nema Type 3R
- Conforms to UL 1741 Standard

0799 Series Includes:

- | | |
|----------|------------------|
| 0799 - 2 | Wire size 2/0-14 |
| 0799 - 5 | Wire size 14-6 |
| 0799 - D | Wire size 14-8 |

Models available in Grey, Black or Stainless Steel

Basic Specifications

Material options:

- Powder coated, 18 gauge galvanized 90 steel (1,100 hours salt spray)
- Stainless steel

Process - Seamless draw (stamped)

Flashing - 15.25" x 17.25"

Height - 3"

Cavity - 255 Cubic inches

Base Plate:

- Fastened to base using toggle fastening system
- 5 roof deck knockouts
- Knockout sizes: (3) .5", (1) .75" and (1) 1"
- 8", 35mm slotted din rail
- Ground Block

Passthrough and combiner kits are available for either AC or DC applications.

0799 Series

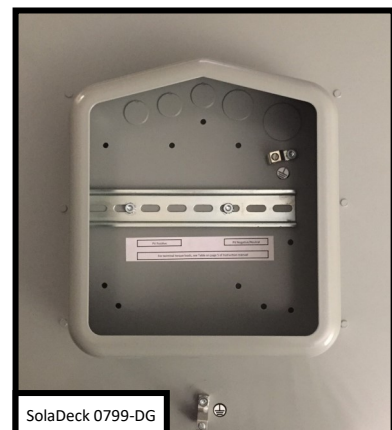
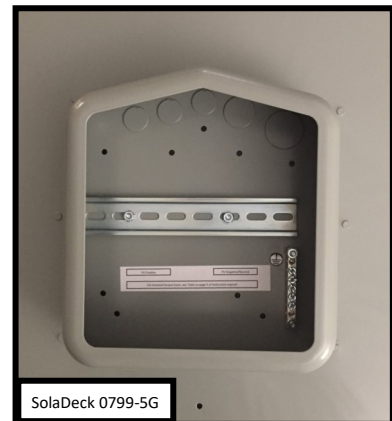
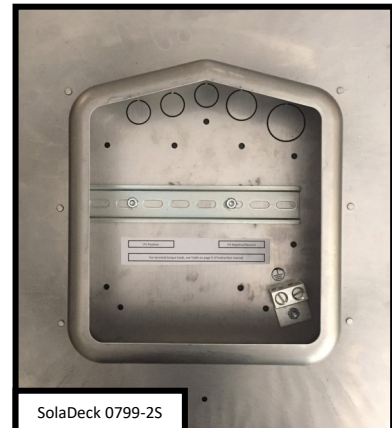

Product data sheet

Specifications

SQUARE D

Green Premium™



Safety switch, general duty, non fusible, 60A, 2 pole, 10hp, 240VAC, NEMA 3R, bolt on provision

DU222RB

Product availability : Stock - Normally stocked in distribution facility

Price* : 353.00 USD

Main

Product	Single Throw Safety Switch
Duty Rating	General duty
Device Application	Residential
Disconnect Type	Non-fusible disconnect switch
Factory Installed Neutral	None
Phase	3 phase
Number of Poles	2
Current Rating	60 A
Voltage Rating	240 V AC
Enclosure Rating NEMA	NEMA 3R
Motor power hp	10 hp at 240 V AC 60 Hz for 1 phase motors

Complementary

Mounting Type	Surface
Electrical Connection	Lugs
Wiring configuration	2 wires
Wire Size	AWG 12...AWG 3 aluminium AWG 14...AWG 3 copper
Tightening torque	35 lbf.in (3.95 N.m) 0.00...0.01 in ² (2.08...5.26 mm ²) (AWG 14...AWG 10) 35 lbf.in (3.95 N.m) (AWG 14...AWG 10) 45 lbf.in (5.08 N.m) 0.01 in ² (8.37 mm ²) (AWG 8) 45 lbf.in (5.08 N.m) 0.02...0.03 in ² (12.3...21.12 mm ²) (AWG 6...AWG 4) 50 lbf.in (5.65 N.m) 0.04 in ² (26.67 mm ²) (AWG 3)
Depth	3.75 in (95.25 mm)
Width	7.75 in (196.85 mm)
Height	9.63 in (244.60 mm)
Net Weight	16.98 lb(US) (7.7 kg)

Environment

Certifications	UL listed file E2875
----------------	----------------------

* Price is "List Price" and may be subject to a trade discount – check with your local distributor or retailer for actual price.

Ordering and shipping details

Category	00106-D & DU SW,NEMA3R, 30-200A
Discount Schedule	DE1A
GTIN	785901491491
Returnability	Yes
Country of origin	MX

Packing Units

Unit Type of Package 1	PCE
Number of Units in Package 1	1
Package 1 Height	5.30 in (13.462 cm)
Package 1 Width	7.20 in (18.288 cm)
Package 1 Length	10.00 in (25.4 cm)
Package 1 Weight	4.65 lb(US) (2.109 kg)
Unit Type of Package 2	PAL
Number of Units in Package 2	120
Package 2 Height	36.50 in (92.71 cm)
Package 2 Width	40.00 in (101.6 cm)
Package 2 Length	48.00 in (121.92 cm)
Package 2 Weight	610.00 lb(US) (276.691 kg)
Unit Type of Package 3	CAR
Number of Units in Package 3	5
Package 3 Height	10.70 in (27.178 cm)
Package 3 Width	10.20 in (25.908 cm)
Package 3 Length	23.50 in (59.69 cm)
Package 3 Weight	24.60 lb(US) (11.158 kg)

Offer Sustainability

Sustainable offer status	Green Premium product
California proposition 65	WARNING: This product can expose you to chemicals including: Lead and lead compounds, which is known to the State of California to cause cancer and birth defects or other reproductive harm. For more information go to www.P65Warnings.ca.gov
REACH Regulation	REACH Declaration
REACH free of SVHC	Yes
EU RoHS Directive	Compliant EU RoHS Declaration
Toxic heavy metal free	Yes
Mercury free	Yes
China RoHS Regulation	China RoHS declaration Pro-active China RoHS declaration (out of China RoHS legal scope)
RoHS exemption information	Yes
Environmental Disclosure	Product Environmental Profile
PVC free	Yes

Contractual warranty

Warranty

18 months

Dimensions

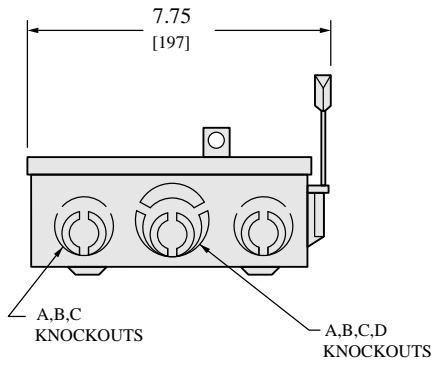
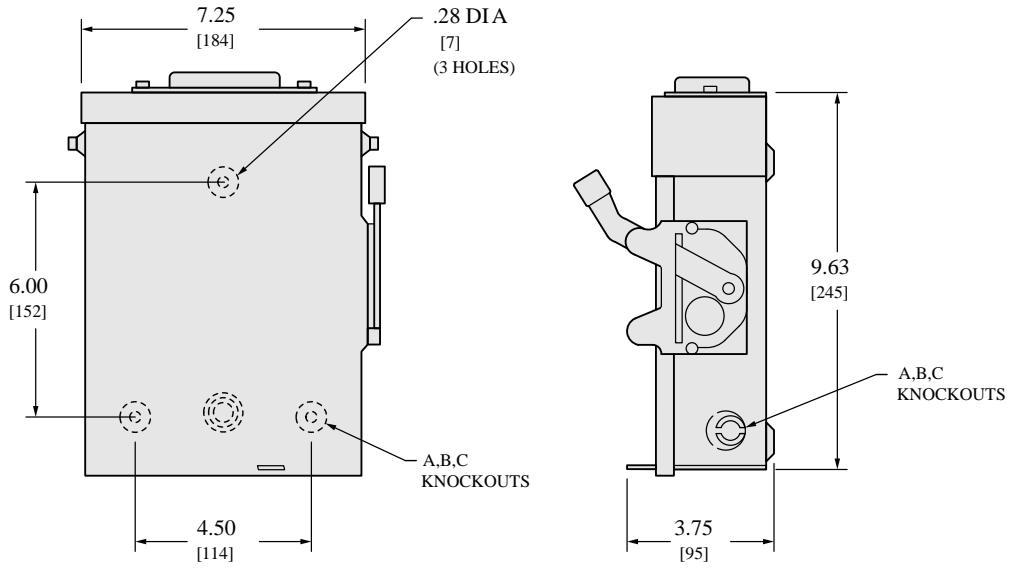

NEMA TYPE 3R

IN.
 [mm]

KNOCKOUTS				
SYMBOL	A	B	C	D
CONDUIT SIZE (IN.)	.50	.75	1	1.25

TOP OF NEMA TYPE 3R SWITCHES HAVE PROVISIONS FOR MAXIMUM 2 1/2" BO LT-ON HUB.
 ALL DIMENSIONS ARE APPROXIMATE. REFER TO TECHNICAL DRAWINGS AND DOCUMENTATION.

Wiring Diagram

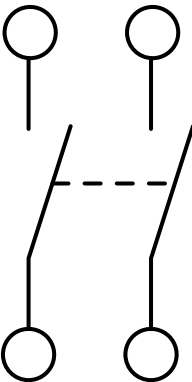

DU222RB

Recommended replacement(s)

XR FLUSH MOUNT

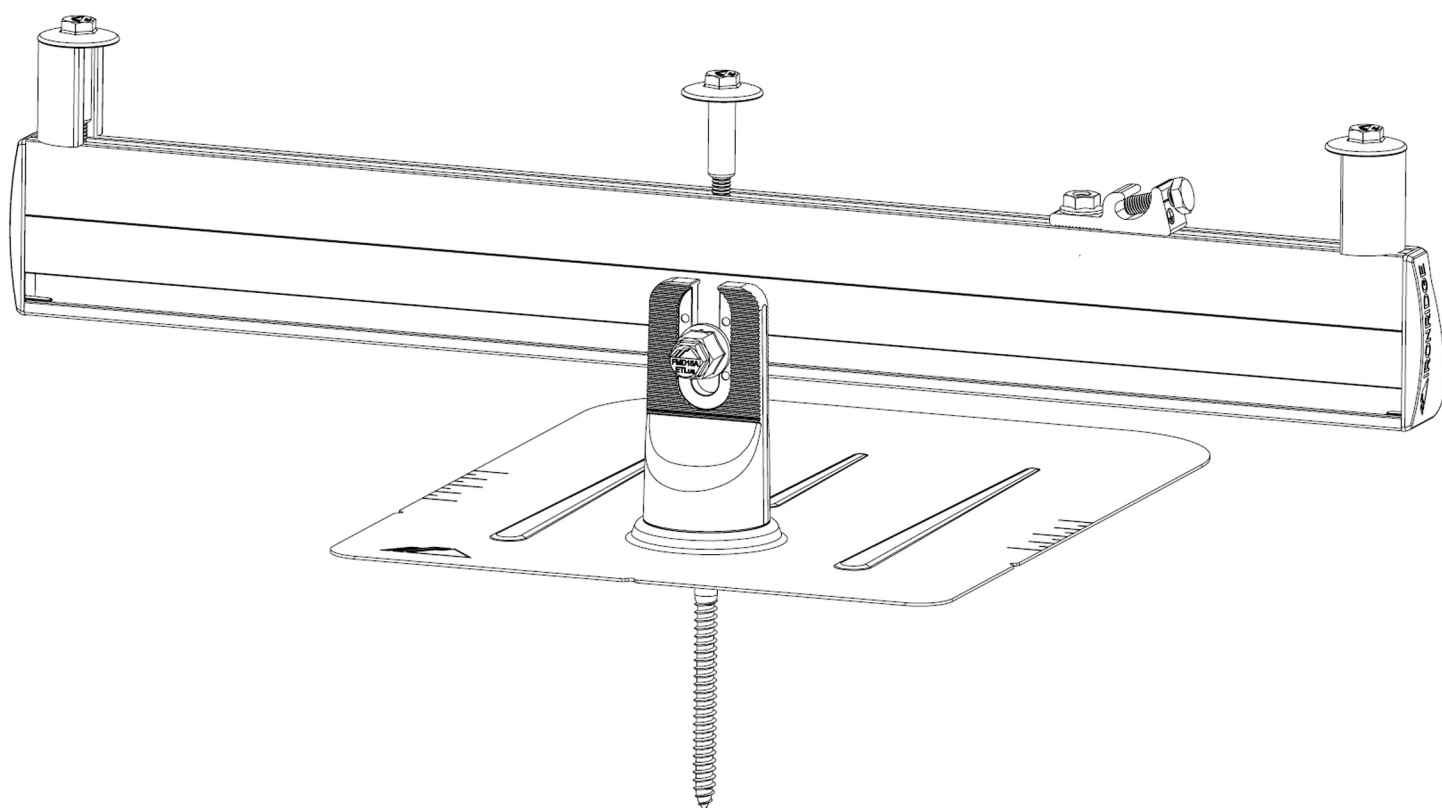

CONTENTS

DISCLAIMER	1
RATINGS	2
MARKINGS	2
ATTACHMENTS	3
COMPONENTS	4
1. ATTACH BASES	5
2. PLACE RAILS	5
3. SECURE LUGS	6
4. SECURE MODULES	6
CAMO	7
BONDING JUMPER	7
EXPANSION JOINTS	8
ELECTRICAL DIAGRAM	9
COMPOSITION SHINGLE	10-12
TILE	13-15
ADDITIONAL ROOF TYPES	15
LOW SLOPE ROOFS	16
CONDUIT PENETRATION	17
CONDUIT MOUNT	18
END CAPS	19
WIRE CLIPS	19
JAYBOX	19
MICROINVERTER KITS	20
SYSTEMS USING ENPHASE MICROINVERTERS OR SUNPOWER AC MODULES	20
SYSTEMS USING MICROSTORAGE PRODUCTS	21
FRAMELESS MODULE KITS	21
CONTOUR	22
MODULE COMPATIBILITY	23-29
FRAMELESS MODULE COMPATABILITY	30

DISCLAIMER

This manual describes proper installation procedures and provides necessary standards required for product reliability. Warranty details are [available on website](#). All installers must thoroughly read this manual and have a clear understanding of the installation procedures prior to installation. Any installation or use of this product not in accord with or not authorized by this written instruction shall void any and all warranties, express or implied, on the product or the use of the product and may cause failure, property damage and personal injury. IronRidge is not liable for any unauthorized use. Install and use only with other IronRidge products to ensure proper fit and function.

IT IS THE INSTALLER'S RESPONSIBILITY TO:

- Ensure safe installation of all electrical aspects of the array. All electrical installation and procedures should be conducted by a licensed and bonded electrician or solar contractor. Routine maintenance of a module or panel shall not involve breaking or disturbing the bonding path of the system. All work must comply with national, state and local installation procedures, product and safety standards.
- Comply with all applicable local or national building and fire codes, including any that may supersede this manual.
- Ensure all products are appropriate for the installation, environment, and array under the site's loading conditions.
- Use only IronRidge parts or parts recommended by IronRidge; substituting parts may void any applicable warranty.
- Review the [Design Assistant](#) and [Certification Letters](#) to confirm design specifications.
- Ensure provided information is accurate. Issues resulting from inaccurate information are the installer's responsibility.
- Ensure bare copper grounding wire does not contact aluminum and zinc-plated steel components, to prevent risk of galvanic corrosion.
- If loose components or loose fasteners are found during periodic inspection, re-tighten immediately. Any components showing signs of corrosion or damage that compromise safety shall be replaced immediately.
- Provide an appropriate method of direct-to-earth grounding according to the latest edition of the National Electrical Code, including NEC 250: Grounding and Bonding, and NEC 690: Solar Photovoltaic Systems.
- Disconnect AC power before servicing or removing modules, AC modules, microinverters and power optimizers.
- Review module and any 3rd party manufacturer's documentation for compatibility and compliance with warranty terms and conditions.
- Ensure that the roof is in good condition prior to installing any IronRidge components.

RATINGS

UL 2703 LISTED



#5003807
#5028987

Intertek

Conforms to UL STD 2703 Standard for Safety First Edition: Mounting Systems, Mounting Devices, Clamping/Retention Devices, and Ground Lugs for Use with Flat-Plate Photovoltaic Modules and Panels

- Scope of Evaluation includes bonding, grounding, mechanical loading, and fire classification
- Max Overcurrent Protective Device (OCPD) Rating: 40A
- Max Module Size: 30.5 ft²
- Module Orientation: Portrait or Landscape
- System Design Load Rating: 10 PSF downward, 5 PSF upward, 5 PSF lateral
- Actual system structural capacity including spans and cantilevers are defined by PE stamped [certification letters](#)
- CAMO Specific Design Load rating: 50 PSF downward, 50 PSF upward, 15 PSF lateral

Certified to CSA TIL No. A-40 Photovoltaic Module Racking Systems

- Load Rating: 2400 PA [50 PSF]

CLASS A SYSTEM FIRE RATING PER UL 2703

- Any Roof Slope with Module Types 1, 2, 3, 13, 19, 25, 29 and 38: Allowed with any roof slope. Any module-to-roof gap is permitted, with no perimeter guarding required
- Module Types 4 and 5: Allowed with Steep Slope Roofs ($\geq 9.5^\circ$). Any module-to-roof gap is permitted, low edge guarding (Trim) required
- Class A rated PV systems can be installed on Class A, B, and C roofs without affecting the roof fire rating

CLASS B SYSTEM FIRE RATING PER UL 2703

- Module Types 4 and 5: Allowed with Steep Slope Roofs ($\geq 9.5^\circ$). Any module-to-roof gap is permitted, with no perimeter guarding required.

WATER SEAL RATINGS:

- UL 441 and TAS100(A) (Flashfoot2, L-Mount, Flashvue, All Tile Hook, Knockout Tile, Halo UltraGrip)
- Tested and evaluated without sealant
- Any roofing manufacturer approved sealant is allowed.
- Ratings applicable for steep roof slopes 2:12 and above.

UL 2703A Ratings:

- Conforms to UL SUBJECT 2703A - Halo UltraGrip and BUG
- Steep Slope Ratings applicable for Asphalt Shingle roofs with slopes 2:12 and up
- Low Slope Ratings applicable for Roll Roofing (Rolled Comp) roofs with slopes 1:12 and up
- Low Slope Ratings applicable for Modified Bitumen (Mod-Bit) roofs with slopes 1/4:12 and up
- Installer must verify roof slope prior to installing HUG or BUG to validate applicable roof types

STRUCTURAL CERTIFICATION

- Designed and Certified for Compliance with the International Building Code & ASCE/SEI-7

FLORIDA PRODUCT APPROVAL #FL29843

- Approved for installation both inside and outside High Velocity Hurricane Zones (HVHZ)
- Additional details and full list of approved components can be found [here](#)

MARKINGS

Product markings are located on the Grounding Lug bolt head.

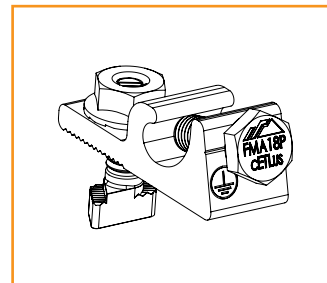
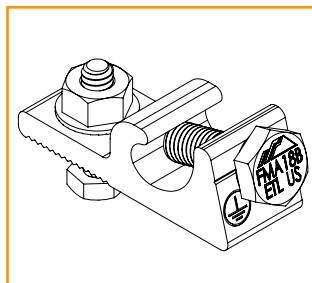

ATTACHMENTS

PRE-INSTALLATION

- Verify module compatibility. See [Page 21](#) for info.

TOOLS REQUIRED

- | | |
|---------------------------------|-----------------------|
| □ Cordless Drill (non-impact) | □ 3/8" Socket |
| □ Impact Driver (for lag bolts) | □ 1/8" Drill Bit |
| □ Torque Wrench (0-250 in-lbs) | □ 1/4" Drill Bit |
| □ 7/16" Socket | □ T30 Bit |
| □ 1/2" Socket | □ Channel Lock Pliers |
| □ 9/16" Socket | □ #3 Phillips Bit |
| □ 7/32" Drill Bit | □ 3/16" Hex Bit |

BONDING HARDWARE TORQUE VALUES

Please refer to each attachment's individual section for full details on all torque values and instructions.

- 3/8" Bonding Hardware Nuts (7/16" Socket): 250 in-lbs
- All Tile Hook Carriage Bolts (7/16" Socket): 132 in-lbs
- Flat Roof Attachment Nuts (9/16" Socket): 250 in-lbs
- Lynx Set Screw (3/16" Hex Drive): 150 in-lbs
- Lynx Flange Nut (1/2" Socket): 150 in-lbs

➤ If using previous version of Integrated Grounding Mid Clamps, End Clamps, Expansion Joints, Classic Composition Mount and for a list of approved 3rd party components please refer to Alternate Components Addendum (Version 2.1)

ATTACHMENTS

COMPOSITION SHINGLE

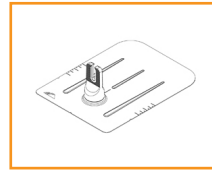

FlashFoot2

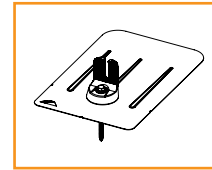

FlashVue

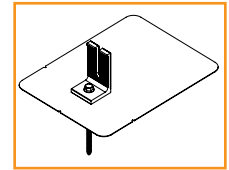

QM L-Mount

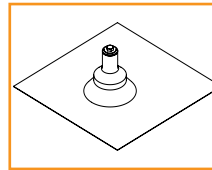

QM QBase

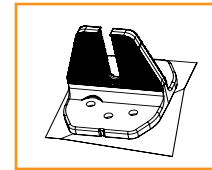

HUG
(Halo UltraGrip)

TILE

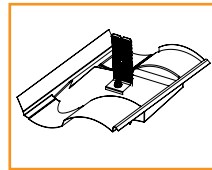

Knockout Tile

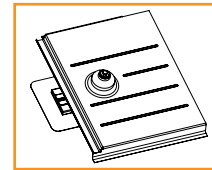

QM Tile Replacement

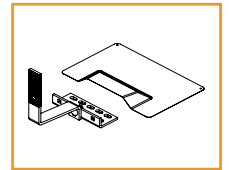

All Tile Hook and
Flashing (optional)

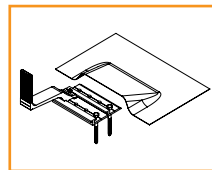

QM Quick Hook and
Flashing (optional)

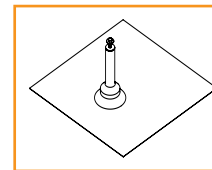

QM QBase Tile

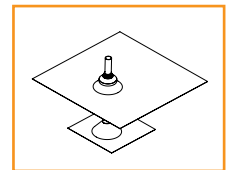

QM Tile Conduit
Penetration

ADDITIONAL ROOF TYPES

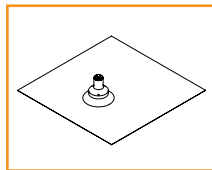

QM Qbase Shake -
Slate - Metal Shingle

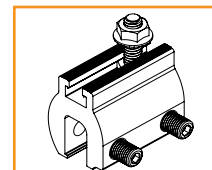

QM Lynx Metal Roof
Attachment

LOW SLOPE ROOF

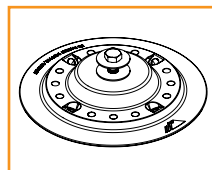

Flat Roof Attachment

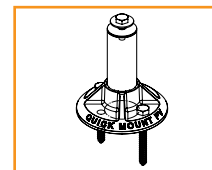

QM QBase Mount

COMPONENTS

PRE-INSTALLATION

- Verify module compatibility. See [Page 21](#) for info.

TOOLS REQUIRED

- Cordless Drill (non-impact)
- Impact Driver (for lag bolts)
- Torque Wrench (0-250 in-lbs)
- 7/16" Socket
- 1/2" Socket
- 9/16" Socket
- 7/32" Drill bit
- 1/8" Drill bit
- 1/4" Drill bit
- T30 Torx Bit
- Channel Lock Pliers
- #3 Phillips Bit
- Paddle Bit

BONDING HARDWARE TORQUE VALUES

Please refer to each attachment's individual section for full details on all torque values and instructions.

- Universal Fastening Object (7/16" Socket): 80 in-lbs
- Rail Grounding Lug Nut (7/16" Socket): 80 in-lbs
- Module Grounding Lug
 - Grounding Nut (7/16" Socket): 60 in-lbs
 - Grounding Lug Terminal Screws (7/16" Socket): 20 in-lbs
- Microinverter Kit Nuts (7/16" Socket): 80 in-lbs
- Frameless Module Kit Nuts (7/16" Socket): 80 in-lbs
- 3/8" Bonding Hardware Nuts (7/16" Socket): 250 in-lbs
- Contour Clamp (T-30 Torx Bit): 80 in-lbs

➤ Unless otherwise noted, all components have been evaluated for multiple use. They can be uninstalled and reinstalled in the same or new location.

COMPONENTS

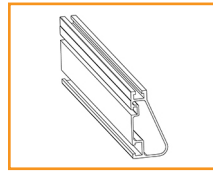

XR Rail



Wire Clip

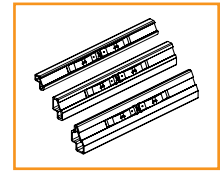

BOSS

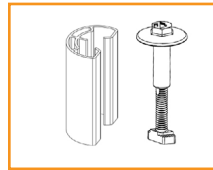

UFO and Stopper Sleeve (30-46MM)

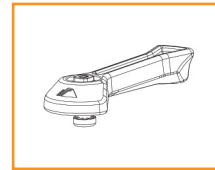

CAMO

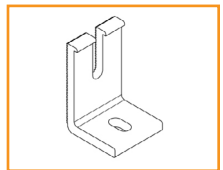

L-Foot



End Cap

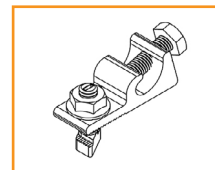

Rail Grounding Lug

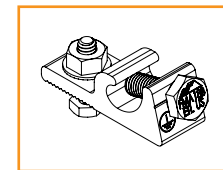

Module Grounding Lug

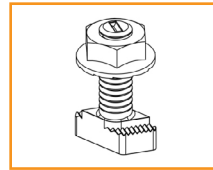

Microinverter Kit

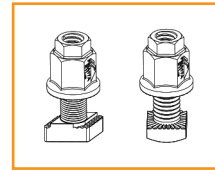

3/8" Bonding Hardware

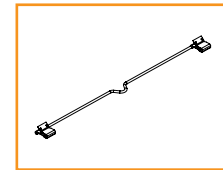

8" Bonding Jumper Single Use Only

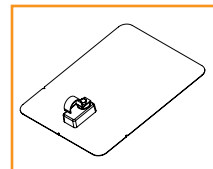

QM Classic Conduit Comp Mount

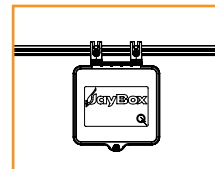

JAYBOX

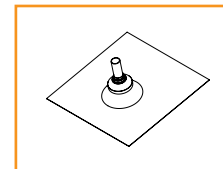

QM Composition Conduit Penetration

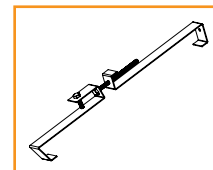

QM Tile Conduit Mount

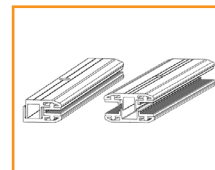

Frameless End/Mid Clamp

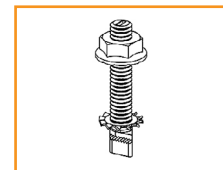

Frameless Module Kit

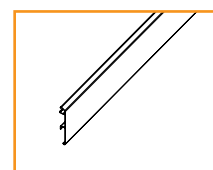

Contour Trim

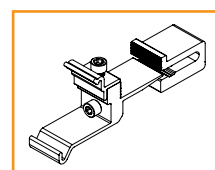

Contour Clamp

1. PLACE ATTACHMENTS

The general installation method for attachments is to locate a rafter, drill a pilot hole and install the attachment. For composition roof attachments installation instructions refer to [page 10](#). For tile roof attachments refer to [page 12](#). For low slope roof attachments refer to [page 14](#). When using approved third party attachments, refer to manufacturer's install instructions.

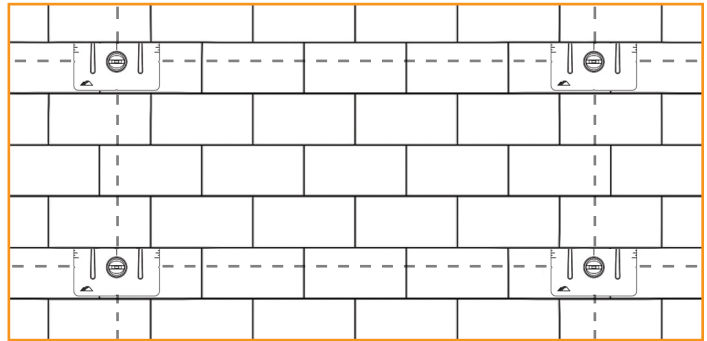

Tested or evaluated third-party roof attachments:

- [S-5! Standing Seam Metal Roof Clamps](#) - Certification of metal roof clamps includes bonding to both painted and galvalume metal roofs. Follow all instructions and installation practices outlined by S-5! in their [Resources Page](#).
- [EcoFasten Green Fasten BF-1 Anchors](#)

2. PLACE RAILS

A. CONNECT SPLICES

Use BOSS(Bonded Structural Splice), as needed, to join multiple sections of Rail.

BOSS - Bonded Structural Splice

Insert BOSS into first Rail up until the Stop Tab. Slide second Rail fully into place.

- Rows using BOSS and exceeding 100 of rail for all roof attachments (60 feet when using HUG) must use [Expansion Joints](#).
- Boss Splices may be installed in any location within a span.
- UFO and Bonding Hardware must be installed 1" away from the point where two Rails join together.

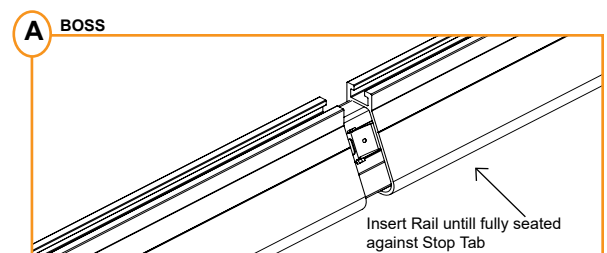

B. PREPARE HARDWARE

Slide square-headed bolts into side-facing rail slot. Space out bolts to match attachment spacing.

- Tape ends of rail, to keep bolts from sliding out while moving.
- If using T-bolts, carry hardware onto roof and proceed.

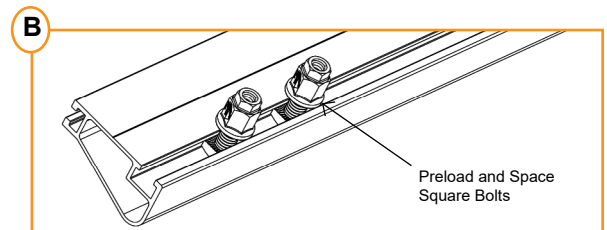

C. ATTACH RAILS

Drop rail with hardware into roof attachment. Level rail at desired height, then torque to 250 in-lbs.

- Rail can face either upslope or downslope on roof.
- When using attachments with longer slots, do not install Rail lower than the top of the L-Foot to avoid damage to modules.

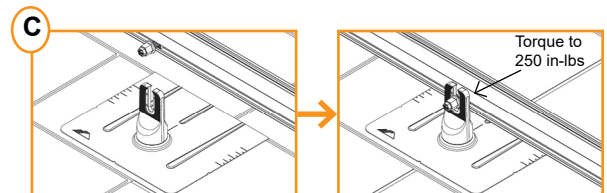

3. SECURE LUGS

Grounding Lugs

Only one Grounding Lug (Rail or Module) required per continuous subarray, regardless of subarray size (Unless frameless modules are used, see [Page 20](#)).

- **Grounding Lugs are intended to for use with one solid or stranded copper wire, conductor size 10-4 AWG.**

Rail Grounding Lug

Insert T-bolt in Top Rail slot and torque Hex Nut to **80 in-lbs**. Install a minimum 10 AWG solid copper or stranded grounding wire. Torque terminal screw to **20 in-lbs**.

- **Module Grounding Lugs can be installed anywhere along the Rail and in either orientation shown.**

Module Grounding Lug

Insert Bolt through Manufacturer approved grounding location and torque Hex nut to **60 in-lbs**. One Module Grounding Lug may be installed to one module per row. Install a minimum 10 AWG solid copper or stranded grounding wire. Torque terminal screw to **20 in-lbs**.

- **If using Enphase microinverters or Sunpower AC modules, Grounding Lugs may not be needed. See [Page 19](#) for more info.**
- **Refer to module manufacturer for mounting location and instructions.**

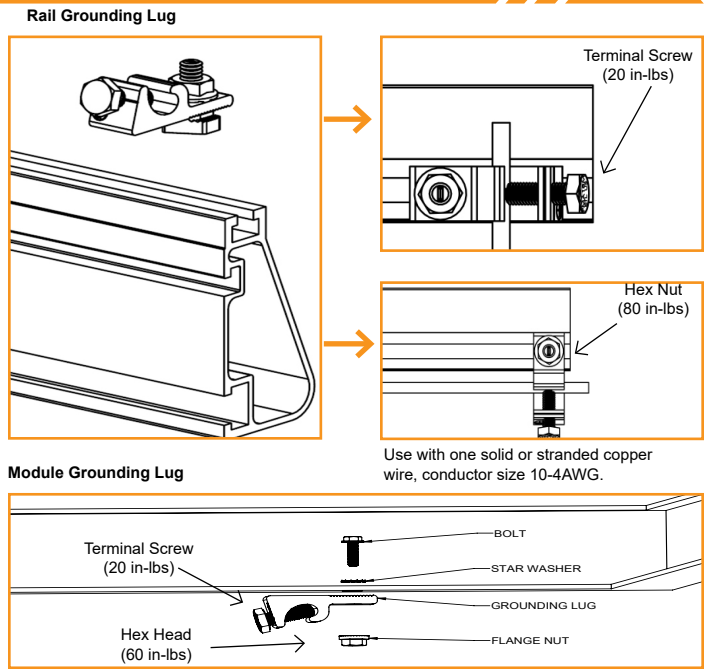

4. SECURE MODULES

A. SECURE FIRST END

Place first module in position on rails, a minimum of 1" from rail ends. Snap Stopper Sleeves onto UFO. Fasten module to rail using the UFO, ensuring that the UFO is hooked over the top of the module. Torque to **80 in-lbs**.

- **Ensure rails are square before placing modules.**
- **Hold Stopper Sleeves on end while torquing to prevent rotation.**
- **If using CAMO instead of UFO + Stopper Sleeve, refer to [Page 19](#) for CAMO installation procedure.**
- **UFO can be installed on modules 30 to 46mm.**

B. SECURE NEXT MODULES

Place UFO into each rail, placing them flush against first module. Slide second module against UFO. Torque to **80 in-lbs**. Repeat for each following module.

- **When reinstalling UFO, move modules a minimum of 1/16" so UFOs are in contact with a new section of module frame.**
- **When UFOs are loosened and re-tightened, ensure UFO T-bolt bottoms out in rail channel before re-torquing UFO to achieve full engagement between T-bolt and rail.**
- **If using Wire Clips, refer to [Page 18](#).**

C. SECURE LAST END

Place last module in position on rails, a minimum of 1" from rail ends. Snap Stopper Sleeves onto UFO. Secure UFO Clamps on rails, ensuring they are hooked over top of module. Torque to **80 in-lbs**.

- **Hold Stopper Sleeves on end while torquing to prevent rotation.**
- **Repeat all steps for each following row of modules, leaving a minimum 3/8" gap between rows**
- **If using CAMO instead of UFO + Stopper Sleeve, refer to [Page 6](#)**

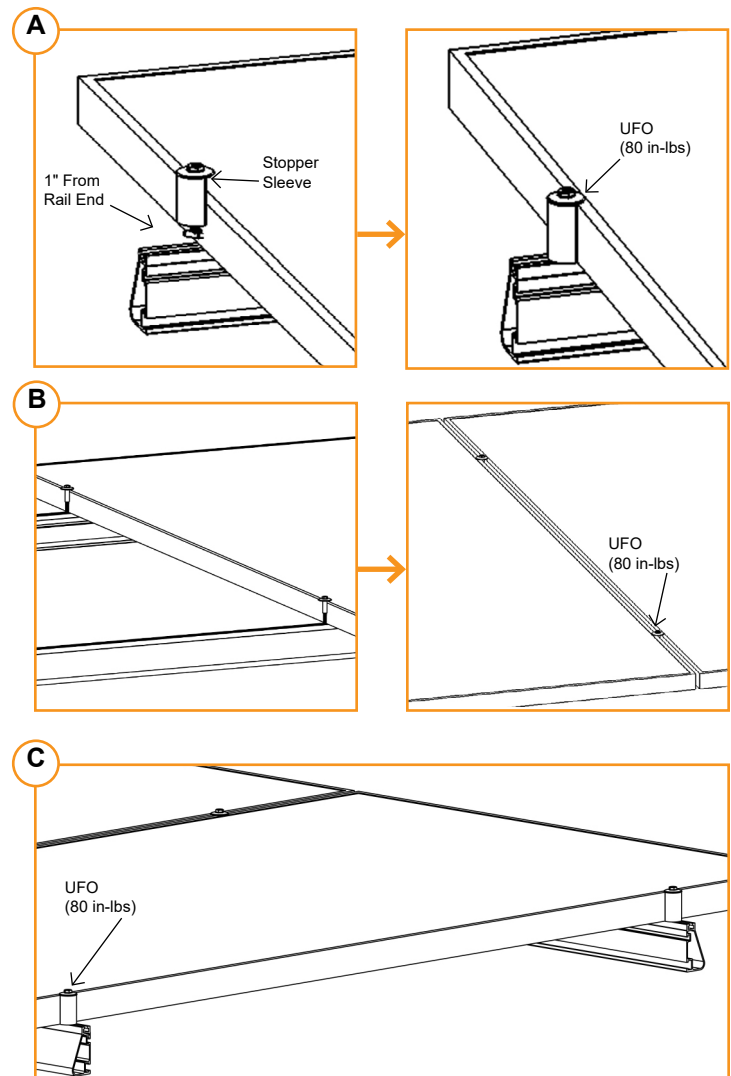

CAMO

A. SLIDE INTO RAIL

Slide CAMO into rail channel far enough to clear the module frame. CAMO requires 6" of clearance from end of rail.



B. PLACE MODULE

Place module on rails (module cells not shown for clarity). When installing CAMO the module can overhang the rail no more than 1/4".

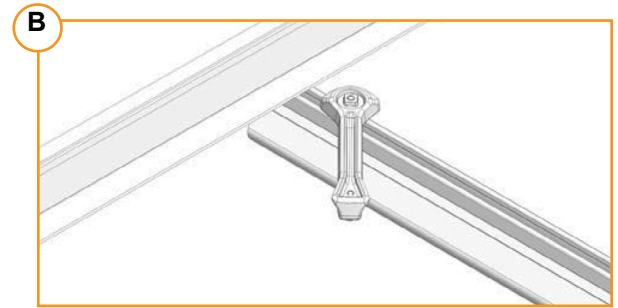

C. PULL TOWARDS END

Pull CAMO towards rail ends, at 45 degree angle, so the bonding bolt contacts the module flange edge.

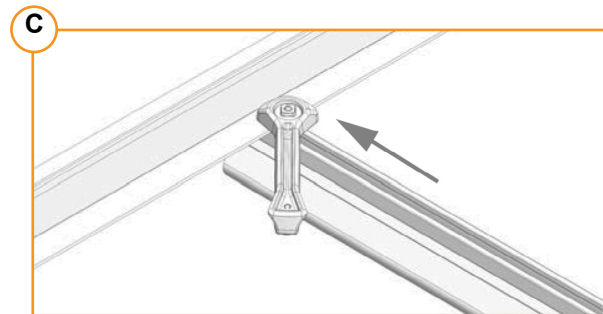

D. SECURE TO FRAME

Rotate handle with an upwards motion until CAMO snaps into rail channel. Ensure CAMO bonding pins are fully seated on top of module frame.

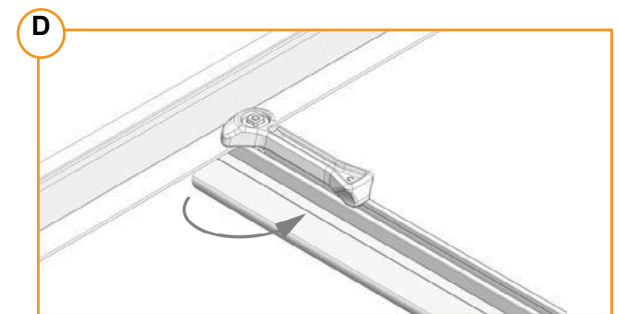

FRAME COMPATIBILITY

CAMO has been tested or evaluated with all modules listed in the Module Compatibility section having frames within the referenced dimensions. Be sure the specific module being used meets the dimension requirements.

- For installations with Hanwha Q CELLS modules with 32 mm frame heights, the maximum ground snow is 45 PSF (33 PSF module pressure).
- CAMO is only compatible with Canadian Solar modules CS1YxxxMS, CS3N-xxxMS, CS6R-xxxMS-HL and CS6W-xxxxMB-AG. "xxx" refers to the module power rating.

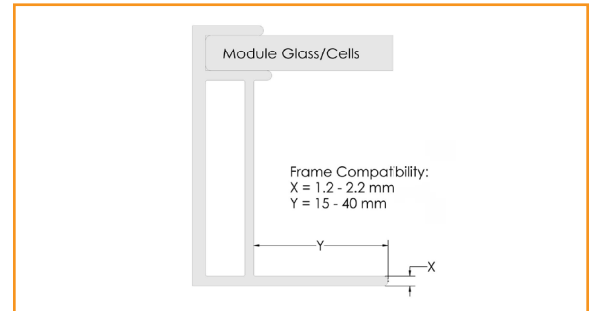

8" BONDING JUMPER

8" Bonding Jumper is an electrical bonding jumper that can be used on the Flush Mount System for row to row bonding; making the module frames the medium for the equipment ground path.

- Bonding jumper is pushed onto the bottom flange of the module.
- New jumpers should be used if re-installation of jumper is required.
- Supports bottom flange thicknesses from 1.2mm to 3.1mm.



EXPANSION JOINTS

Expansion Joints are required every 100' of continuous rail to allow for thermal expansion and contraction of the system.

- Do not install modules over expansion joint.
- Expansion Joints are required every 60' of continuous rail when installing on HUG.

BOSS

Insert BOSS into first Rail up to the Alignment Circle, Slide second Rail over BOSS to the second Alignment Circle, leaving a 1" gap between the Rails.

There must be a 1" of space between the edge of the Rail and the edge of the panel to allow proper installation of the UFO and Stopper Sleeve.

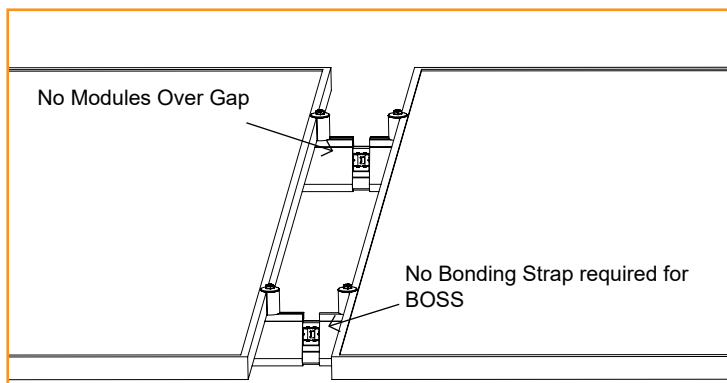
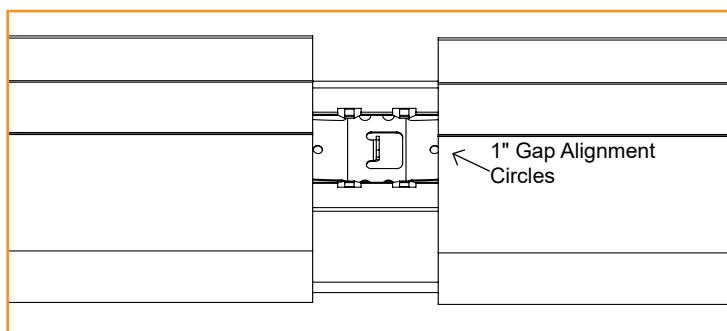
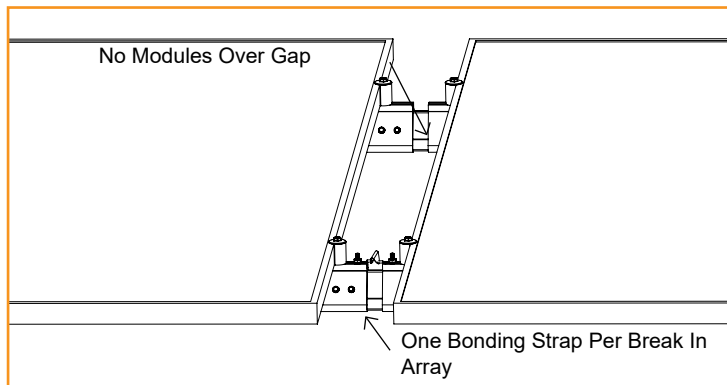

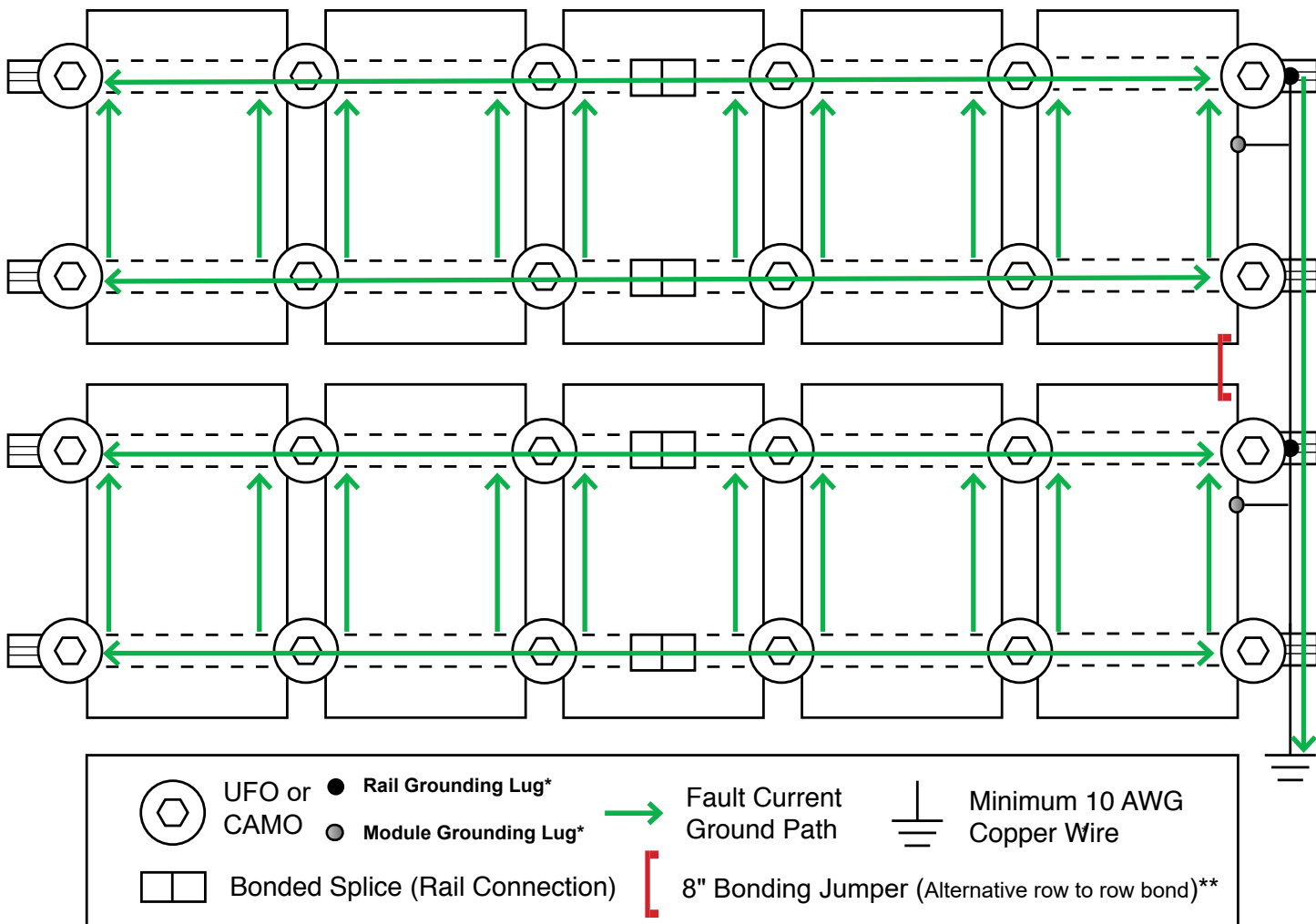

*One Module Grounding Lug or Rail Grounding lug is required per row of a system.

** The use of the 8" Bonding Jumper eliminates the need for row to row bonding. A minimum of one grounding lug per continuous array is required for earth ground.

Grounding Lugs and wire are not required in systems using certain Enphase microinverters or certain Sunpower modules. Equipment grounding is achieved with the Engage cable for Enphase or the AC module cable system for Sunpower via their integrated EGC.

FLASHFOOT2

Locate roof rafters and mark locations on roof. Drill 1/4" pilot holes perpendicular to the roof and back fill with roofing manufacturers' approved sealant. Slide flashing between 1st and 2nd course of shingles, ensuring both that the flashing reaches under the 3rd shingle course and doesn't overhang the downhill shingle course. Line up with pilot hole and insert supplied lag bolt with washer through flashing. With a 7/16" Socket fully seat lag bolt. Place Cap onto flashing in desired orientation for E/W or N/S rails and rotate 180 degrees until it locks into place.

- Rail can be installed on either side of FlashFoot2 Cap.
- For additional details refer to the full FlashFoot2 [Installation Manual](#).

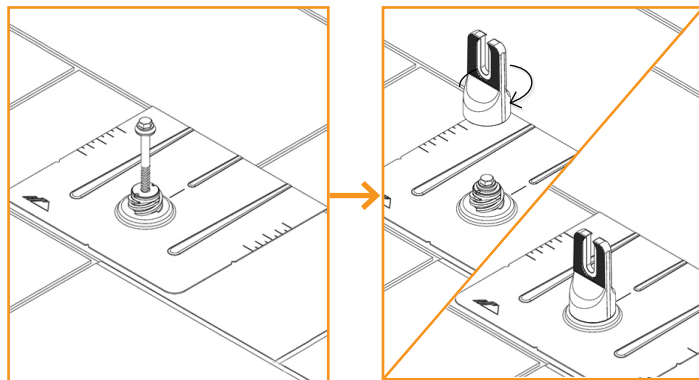

FLASHVUE

Locate rafters and snap vertical and horizontal lines to mark locations of flashings. Drill 1/4" pilot holes, then backfill with an approved sealant. Slide flashing between 1st and 2nd course of shingles, ensuring both that the flashing reaches under the 3rd shingle course and doesn't overhang the downhill shingle course. Line up pilot hole with View Port. Press Grip Cap onto flashing in desired orientation for E/W or N/S rails. Insert Lag Bolt with mechanically bonded washer through flashing. With a 7/16" Socket drive Lag Bolt until fully seated. FlashVue is now installed and ready for IronRidge XR Rails. Attach rails to either side of the open slot using bonding hardware. Level rail at desired height, then torque to **250 in-lbs (21 ft-lbs)**.

When installing GripCap+ on roofs with undulations greater than 1 inch, install GripCap+ in low points across the array as required.

- For additional details refer to the full FlashVue [Installation Manual](#).
- For additional details on the GripCap+ refer to the full GripCap+ [Installation Manual](#).

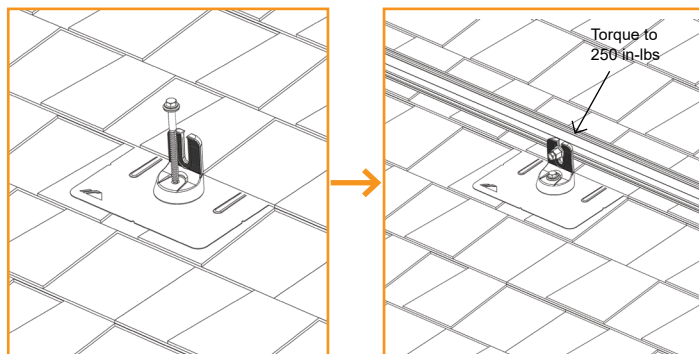

QM L-MOUNT

Locate roof rafters and mark locations on roof. Drill 7/32"(Lag) or 1/8"(ST) pilot holes perpendicular to the roof and back fill with roofing manufacturers' approved sealant. Slide flashing between 1st and 2nd course of shingles, ensuring both that the flashing reaches under the 3rd shingle course and doesn't overhang the downhill shingle course. Place L-foot on flute and rotate into desired position. Prepare lag bolt or structural screw with sealing washer. Use 1/2" socket to drive prepared lag bolt through L-foot until fully seated and L-foot can no longer rotate easily. Torque Nut to **156 in-lbs (13 ft-lbs)** for ST. Attach rail to L-Foot with Bonding Hardware and torque to **250 in-lbs (21 ft-lbs)**.

- Structural screw can be driven with T-30 hex head bit.
- For additional details refer to the full QM [Installation Manual](#).

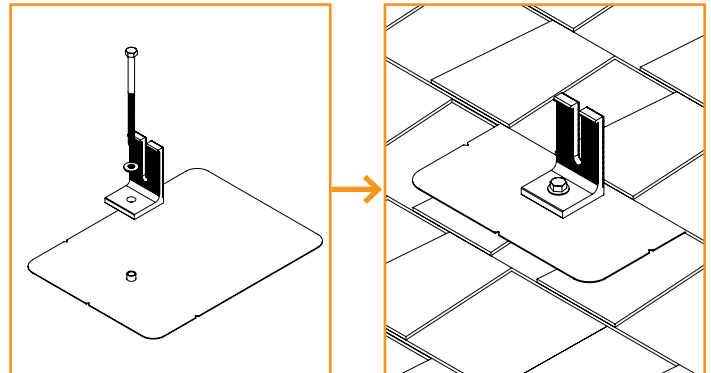

QM QBASE COMPOSITION MOUNT

Locate roof rafters and mark locations on roof. Align QBase vertical holes over center rafter and mark. Drill two pilot holes with 7/32" drill bit, perpendicular to roof and back fill with roofing manufacturers' approved sealant. Set grade 8 cap screw through bottom of QBase, place QBase over drilled holes and secure lags. Screw Post to QBase. Proceed with roofing up until the flashing should be installed. Install flashing over mount. Allow roofing to proceed to the next course. Apply sealant where post and flashing meet, install EPDM counter flashing collar. Attach L-Foot on Standoff with hardware. Torque to **174 in-lbs (14.5 ft-lbs)**. Attach rail to L-Foot with Bonding Hardware and torque to **250 in-lbs (21 ft-lbs)**.

- For additional details refer to the full QM [Installation Manual](#).

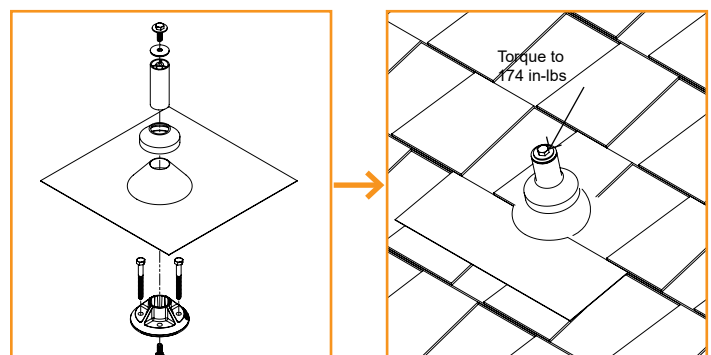

HUG (RAFTER)

Confirm shingle step does not exceed 1/8". Locate and mark centers of rafters to be mounted. Select the courses of shingles where mounts will be placed. Peel off release liner. Align HUG horizontally using the shingle edge or chalk line with the alignment grooves on the mount. Once in desired location, lightly press against roof to preliminarily hold the mount in place. Drive RD Structural Screw using 5/16" socket, ensuring that two screws are correctly installed into the center of the rafter. Drive screws until fully seated.

- Rail can be installed on either side of HUG.
- For complete installation requirements and limitations, please refer to the HUG [Installation Manual](#).
- HUG is only approved for installation with IronRidge RD Structural Screws.
- HUG cannot be installed between courses.

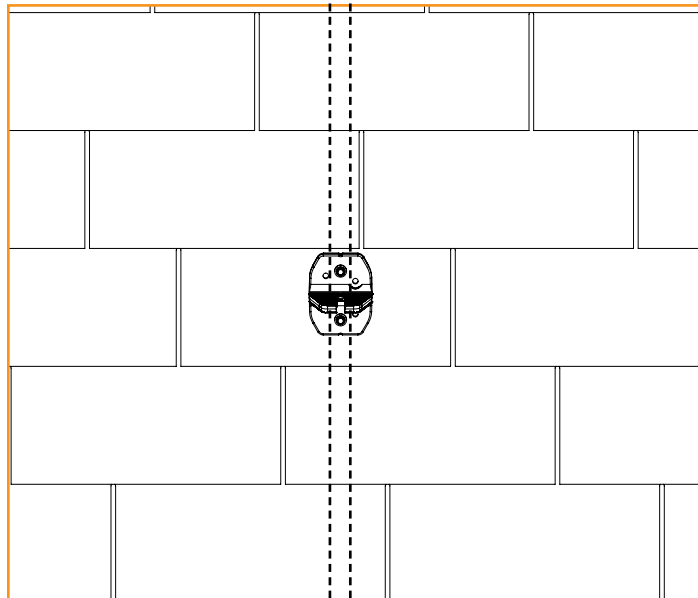

HUG (DECK)

Confirm shingle step does not exceed 1/8". Locate and mark attachment locations. Select the courses of shingles where mounts will be placed. Peel off release liner. Align HUG horizontally using the shingle edge or chalk line with the alignment grooves on the mount. Once in desired location, lightly press against roof to preliminarily hold the mount in place. Drive screws using 5/16" socket, until fully seated. All 6 RD Structural Screws must be used in deck mounted conditions.

- Rail can be installed on either side of HUG.
- For complete installation requirements and limitations, please refer to the HUG [Installation Manual](#).
- HUG is only approved for installation with IronRidge RD Structural Screws.
- Rows of rail exceeding 60 feet require a thermal expansion joint when using HUG.

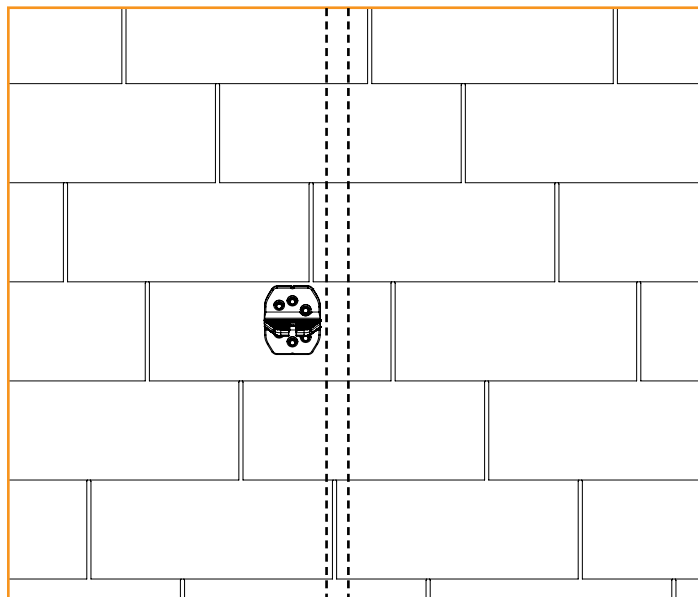

ALL TILE HOOK

Remove tile and mark rafter. Position base over rafter, adjust arm if necessary and torque hardware to **132 in-lbs (11 ft-lbs)**. Use base as guide to drill 1/4" pilot holes, back fill with roofing manufacturer's approved sealant, then insert lag bolts and tighten until fully seated. Replace tiles and notch as necessary to ensure proper fit. Attach rails to either side of slot using Bonding Hardware and torque to **250 in-lbs (21-ft-lbs)**.

- Position arm near the center of valley for curved tiles.
- Position arm away from seam of joining flat tiles.
- Ensure top of hook does not extend above rail.
- Standalone [All Tile Hook manual](#) available on website.

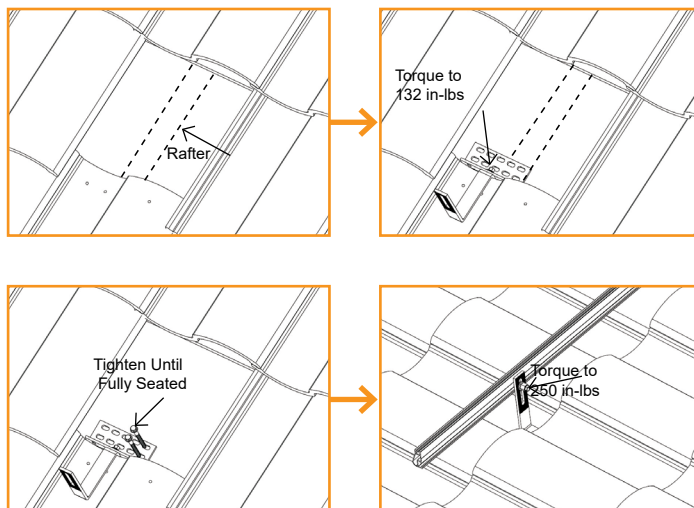

QM QUICK HOOK

Remove tile and mark rafter, use Base Plate to mark two holes on rafter. Drill two 7/32" pilot holes and back fill with roofing manufacturers' approved sealant. Use 1/2" socket to drive lag into place. Slide hook into place and adjust to desired position. Drive self-tapping screw using a #3 Phillips bit to lock hook in place. Clean underlayment and apply a bead of sealant compatible with roofing manufacturer, install flashing over mount. Fasten sub-flashing to deck with one roofing nail in each corner. Waterproof at underlayment level according to roofing manufacturers' instructions and the Tile Roofing Industry Alliance guidelines. Cut clearance notch in the weather guard of tile as needed or utilize QM Tile Replacement Flashings. Attach rails to either side of slot using Bonding Hardware and torque to **250 in-lbs (21-ft-lbs)**.

- Position arm near the center of valley for curved tiles.
- Position arm away from seam of joining flat tiles.
- Ensure top of hook does not extend above rail.
- For additional details refer to the full QM [Installation Manual](#).

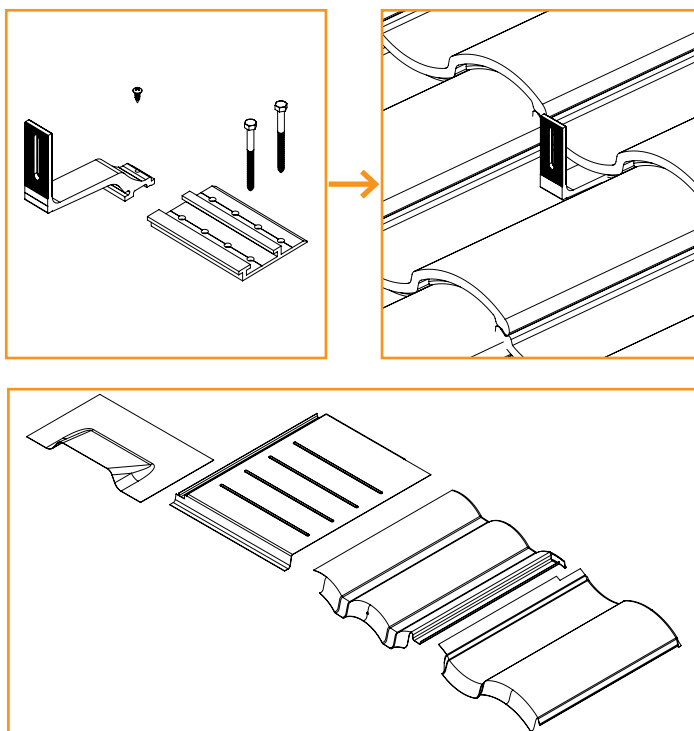

TILE

QM QBASE UNIVERSAL TILE MOUNT

Remove tile and mark rafter. Measure up 6 5/8" from bottom of tiles and mark horizontally. Align QBase over rafter center and drill two 7/32" pilot holes, back fill with roofing manufacturers' approved sealant. Place grade-8 Cap Screw under QBase, lag QBase into rafter location. Install Sub-flashing, waterproof at underlayment level according to roofing manufacturers' instructions and the Tile Roofing Industry Alliance guidelines. Cut tile with diamond blade to allow post to pass through. Place tile in position and then install Post. Install 18"x18" flashing, pre-bent to follow the contour of the tile as required. Apply sealant where Post and Flashing meet and install EPDM counter flashing. Attach L-Foot on Standoff with hardware. Torque to **174 in-lbs (14.5 ft-lbs)**. Attach rails to L-Foot using Bonding Hardware and torque to **250 in-lbs (21-ft-lbs)**.

➤ For additional details refer to the full QM [Installation Manual](#).

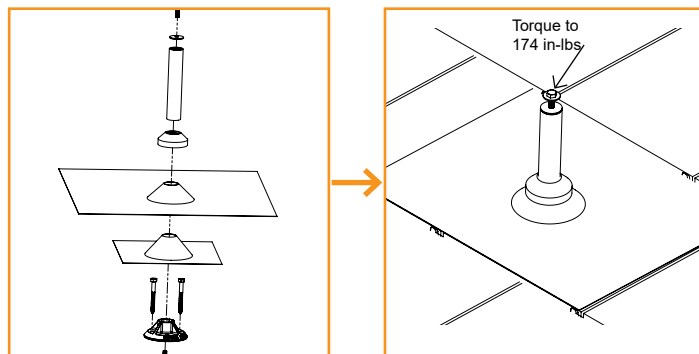

ADDITIONAL ROOF TYPES

QM QBASE METAL, SHAKE AND SLATE

The QM QBase can be used to install on multiple roofing types with different installation methods.

- For instructions on installing the QBase on Slate refer to the full QM [Installation Manual](#).
- For instructions on installing the QBase on Shake refer to the full QM [Installation Manual](#).
- For instructions on installing the QBase on Metal Shingle refer to the full QM [Installation Manual](#).

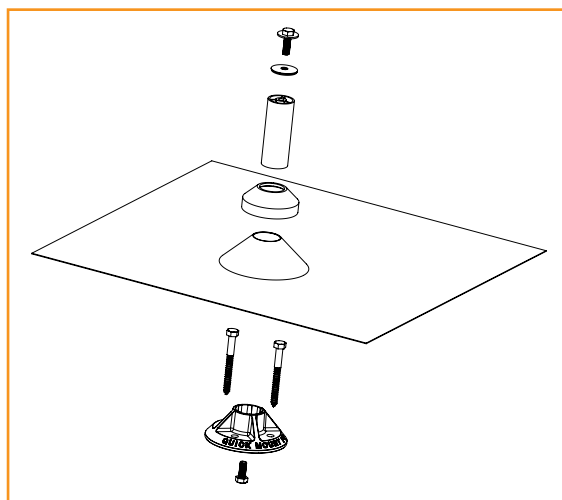

LOW SLOPE ROOFS

FLAT ROOF ATTACHMENT

Flat Roof Attachment can be used with an L-foot for flush mounting modules on low sloped roofs. Mark locations for Flat Roof Attachment. Screws should be installed symmetrically to each other. If using a membrane flashing, remove the silicone washer's protective liner prior to attaching the membrane. Attach L-foot with washers and 3/8" hardware torqued to **250 in-lbs (21 ft-lbs)**. Seal attachment and/or membrane per roofing manufacturer's requirements.

- **Type, size, and quantity of roof screws to be specified by Structural Engineer. Fastener size not to exceed #15.**
- **Membrane flashing available for TPO, PVC, and KEE roofs. Ensure membrane flashing is compatible with existing roofing material.**
- **If membrane flashing is not used, only washer on top of L-Foot is required.**
- Standalone [Flat Roof Attachment Manual](#) available on website.

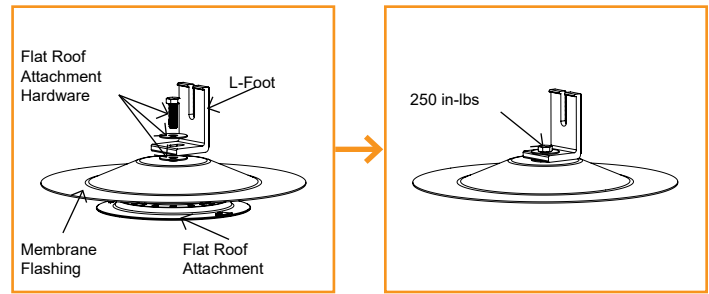

QM QBASE MOUNT

Locate the desired mount placement over a rafter. Using the base as a template, mark the two penetration points. Drill two 7/32" pilot holes, back fill with roofing manufacturers' approved sealant. Place the grade-8 hex bolt in the bottom of the base and screw the Post. Attach L-Foot on Standoff with hardware. Torque to **174 in-lbs (14.5 ft-lbs)**. Attach rail to L-Foot with Bonding Hardware and torque to **250 in-lbs (21 ft-lbs)**.

The mount can be flashed with available 9", 12" or 18" aluminum flashings, pitch pocket or curb, or with a membrane cone flashing. If using a membrane flashing utilize the services of a qualified roofer

- For additional details refer to the full QM [Installation Manual](#).

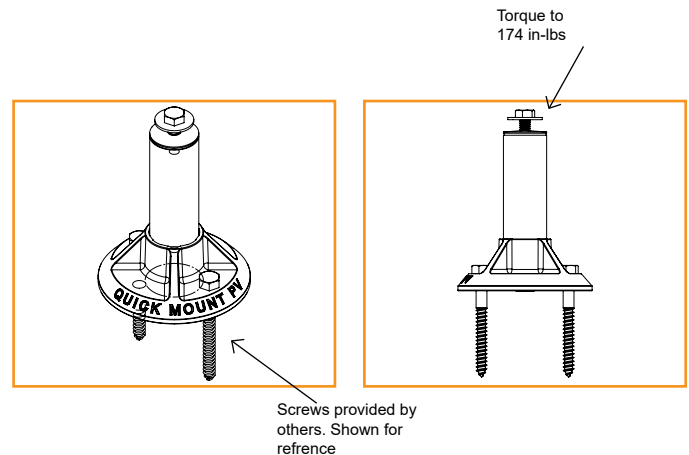

METAL ROOF

QM LYNX

Locate the desired mount placement over a roofing seam, make sure block is fully seated on metal seam. Torque Set Screws to **150 in-lbs(12.5 ft-lbs)** using 3/16" Hex Drive, alternate driving each bolt till required torque is met. Slide Hex Bolt into slot and to desired position. Place rail attachment bracket over Hex Bolt and secure with Flange Nut, torque Flange Nut to **150 in-lbs(12.5 ft-lbs)** using 1/2" socket.

- For additional details refer to the full QM [Installation Manual](#).
- Certification of Lynx calmp includes bonding to both painted and galvalume metal roofs.
- The technology in this product is licensed by S-5!

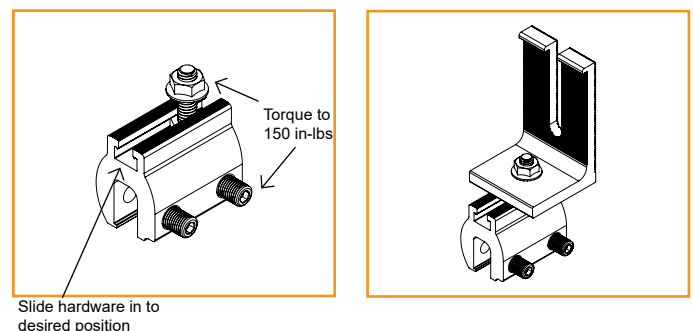

CONDUIT PENETRATION FLASHINGS

QM CONDUIT PENETRATION FLASHING - COMP SHINGLE

Mark a drill point so that the flashing reaches up to the 3rd shingle course. Drill your conduit hole next to the rafter so you can secure the conduit below the roof surface. Cut shingle and remove nails as needed to center the drilled hole and flashing hole. Apply roofing manufacturer's approved sealant on the underside of the flashing in a Upside down U and to top of flashing. Under the 3rd course and through the second course secure flashing with 2 roofing nails, apply sealant over the nail heads. Cut EPDM collar to appropriate size. Apply a bead of sealant compatible with the roofing manufacturer and EPDM rubber to anywhere the EPDM collar contacts.

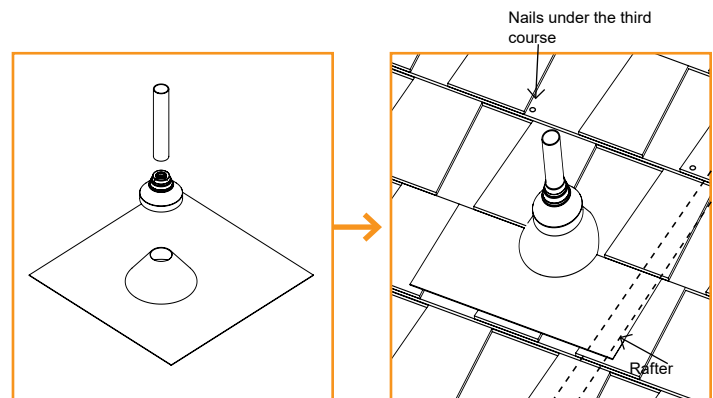

- Be sure to secure conduit to rafters below the roof surface per local building codes and NEC code requirements.
- Cut EPDM collar to appropriate size using the sizing chart in the installation manual, approved for 1/2" to 1" EMT.
- For additional details refer to the full QM [Installation Manual](#).

QM CONDUIT PENETRATION FLASHING - TILE

Drill your conduit hole next to the rafter so that you can secure the conduit below the roof surface. Apply roofing manufacturer approved sealant to the underside of the sub-flashing in the shape of an upside down U. Clear away any dust and debris to install sub-flashing. Waterproof at under laminate level according to roofing manufacturer instructions and Tile Roofing Institute Guidelines. Under the top layer of felt, secure the sub-flashing with two roofing nails. Cut EPDM collar to appropriate size. Apply a bead of sealant compatible with the roofing manufacturer and EPDM rubber to anywhere the EPDM collar contacts. With a diamond blade cut tile to allow conduit to pass through, replace all tiles. Bend the flashing to follow the contour of the tiles. Place flashing over the conduit and tuck up under the next course of tiles. Apply a bead of sealant compatible with the roofing manufacturer and EPDM rubber to anywhere the EPDM collar contacts. Slide collar onto conduit all the way down to the flashing.

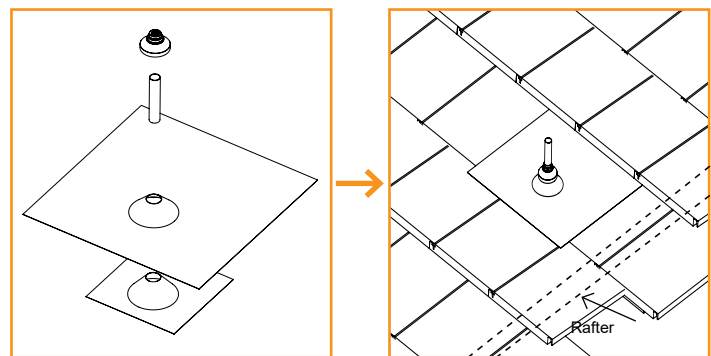

- Be sure to secure conduit to rafters below the roof surface per local building codes and NEC code requirements.
- Cut EPDM collar to appropriate size using the sizing chart in the installation manual, approved for 1/2" to 1" EMT.
- For additional details refer to the full QM [Installation Manual](#).

CONDUIT MOUNT

QM CONDUIT MOUNT - COMPOSITION SHINGLE

Place conduit mounts along path of conduit. Lift shingle above mount location and insert flashing into position. Mark center for drilling, remove flashing and drill pilot hole with 1/8" bit. Clean area, fill hole with roofing manufacturer's approved sealant. Lift shingle and slide Conduit Mount into place. Prepare the lag bolt with sealing washer and pipe clamp (not included). Insert lag through hole in block and drill with 7/16" socket until block is tight.

- Install mounts as required to support conduit across the roof.
- For additional details refer to the full QM [Installation Manual](#).

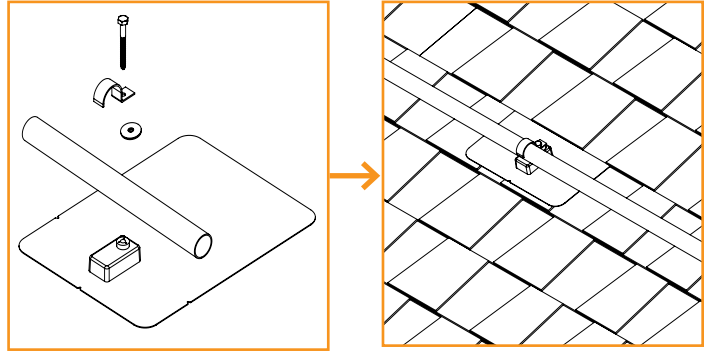

QM BUG - COMPOSITION SHINGLE

Place BUG conduit mounts along path of conduit. Clean area, place mount and drive RD Structural Screw using 5/16" socket. Prepare the Tri-lobe Screw and pipe clamp (not included). Insert screw in an unused hole in block and drill with 5/16" socket until screw is tight.

- Install mounts as required to support conduit across the roof.
- For additional details refer to the full QM [Installation Manual](#).

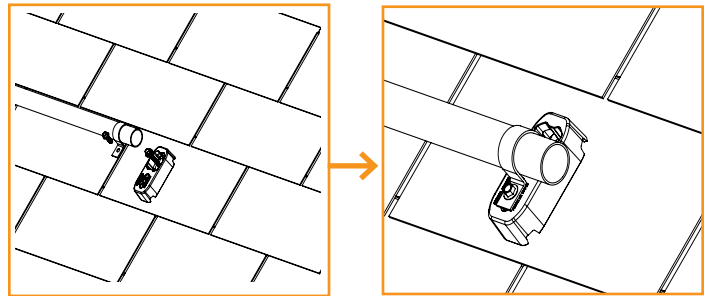

QM CONDUIT MOUNT - TILE

Remove the tile that the mount will be installed on, and the tiles in the course above it. Lift the bottom of the tile and slide the bottom clamp over the bottom edge of the tile. Insert the 4" tap bolt through the slot into the threaded hole and use a 7/16" socket to thread the screw. Tighten until the top clamp hook end unbends and forms a 90 degree angle with the tile. Use the Cap Screw (included) to attach your pipe clamp (not included) to bottom clamp. Insert conduit and tighten with 7/16" socket.

- The clamp is reversible, use the wider hook end on tile greater than 1" thick and the thinner hook end on tiles less than 1" thick.
- The installation process is the same on curved tile, make sure that the Conduit Mount is installed on the crown (high point) of the tile.
- Install mounts as required to support conduit across the roof.
- For additional details refer to the full QM [Installation Manual](#).

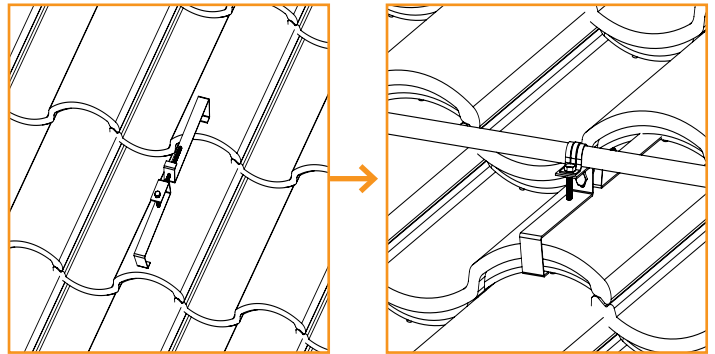

END CAPS

End Caps add a completed look and keep debris and pests from collecting inside rail.

Firmly press End Cap onto rail end.

- End Caps come in sets of left and right. Check that the proper amount of each has been provided.

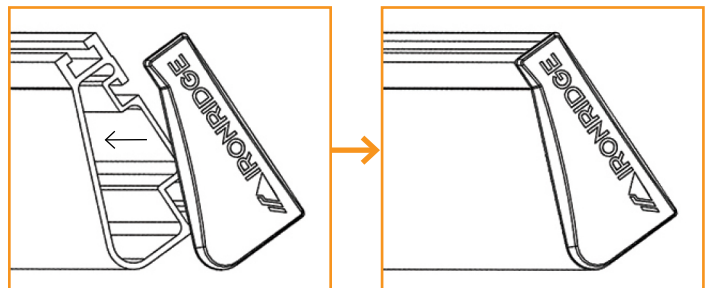

WIRE CLIPS

Wire Clips offer a simple wire management solution.

Firmly press Wire Clip into top rail slot. Run electrical wire through open clip. Snap closed once all wires have been placed.

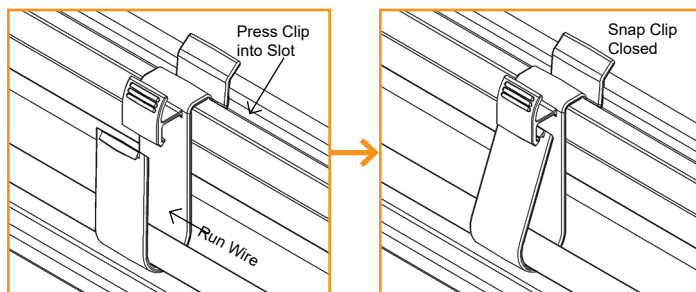

JAYBOX

A.

Prior to installation, use step drill bit to place pass through holes for conduits or water-tight connectors. Drill bit starter locations are provided on the sides and front of enclosure.

- Do not install conduit facing up roof.

B (Rail).

Use rail-specific MLPE mounting hardware to attach Rail Hangers to rail. Ensure junction box is pushed as close to the rail as possible. Torque to 80-in lbs (1/2" or 7/16" socket).

- Do not overtighten
- If installing in areas with ground snow loads greater than 40 psf, install JayBox under module directly next to module frame edge.

B (Shingle).

Align sealing oval of box to align with mating feature on flashing. An EPDM foam gasket is pre-installed to the underside of the junction box to seal the flashing to the box without the need for additional sealant. Secure with supplied #12 x 1-3/4" deck screws (2x) until the junction box is pulled tight to the flashing. Do not over-tighten screws to avoid stripping screws in OSB.

- If installing pass through fittings, ensure that the JayBox and roof deck are both properly prepared. Complete installation process before attaching the Jaybox to the deck.
- Do not install JayBox under shingle seam as illustrated below.

C.

Install wiring, conduit and fittings per NEC requirements and following local AHJ guidance. Using Philips Head Driver tighten the bolt.

- For additional details refer to the full QM [Installation Manual](#).

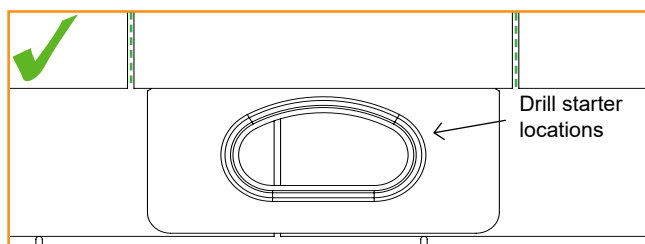
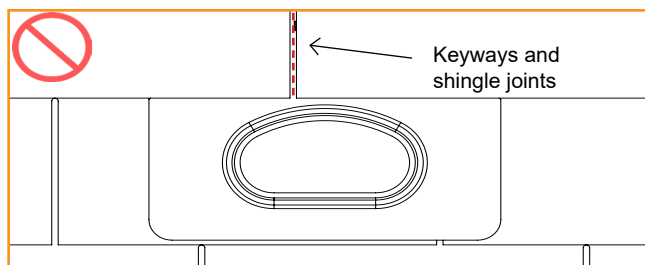
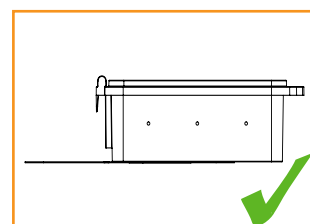
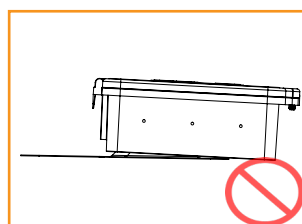
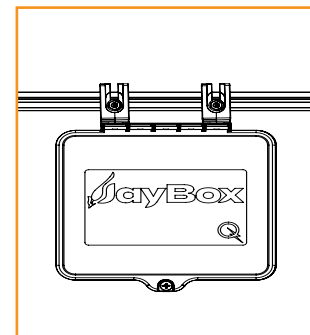
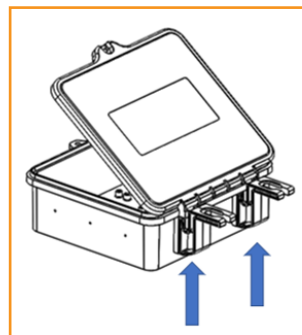
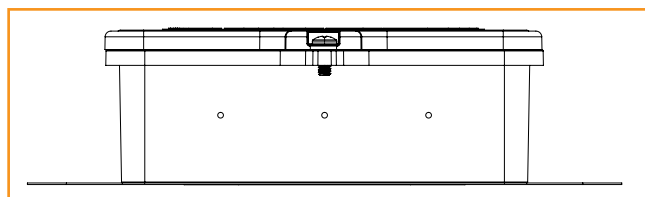

MICROINVERTER KITS

Use IronRidge's Microinverter Kit to bond compatible microinverters and power optimizers to the racking system. Insert Microinverter Kit T-bolt into top rail slot. Place compatible microinverter or power optimizer into position and tighten hex nut to **80 in-lbs**.

- MLPE devices shall be installed near modules frames whenever possible.

Enphase

M250-72, 250-60, M215-60, C250-72, S230, S280, IQ 6, IQ 6+, IQ7, IQ 7A, IQ 7+, IQ7 PD, IQ 7X, Q Aggregator; IQ8-60, IQ8PLUS-72, IQ8A-72, IQ8H-208-72, IQ8H-240-72, IQ8M-72, may be followed by -2-US; IQ8H-3P-72-E-US or IQ8P-3P-72-E-US

Darfon

MIG240, MIG300, G320, G640

Solar Edge

M1600, P300, P320, P340, P370, P400, P401, P405, P485, P505, P600, P700, P730, P750, P800p, P800s, P801, P850, P860, P950, P960, P1100, P1101, S440, S500, S500B, S650B, S1200, S1201

SMA

RoofCommKit-P2-US, TS4-R Module Retrofit Kits (TS4-R-S, TS4-R-O, TS4-R-F)

Generac

S2502

Hoymiles

HMA-xxxYY-ZZ

where "A" can be blank or S, xxx can be 300, 350, 400, 450, 500, 600, 700, 800, 900, 1000, 1200, 1500, 1600, 1800 or 2000; "YY" can be NT, 1T, 2T, 4T; and "ZZ" can be blank, NA or 208-NA

Yotta

DPI 208/480

Tigo

Tigo Access Point (TAP)

TS4-R-X (where X can be F, M, O, or S)

TS4-R-X-DUO (where X can be M, O, or S)

TS4-A-X (where X can be F, 2F, O, O-DUO, or S)

TS4-X (where X can be F, O and S)

AP Systems

DS3, QS1, QT2 and YC600

NEP

BDM-300, BDM-300X2, BDM-550, BDM-650 and BDM-800

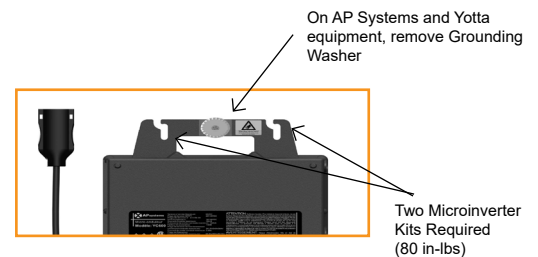
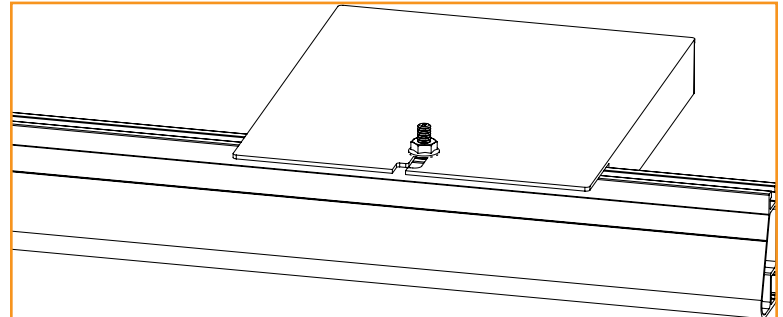
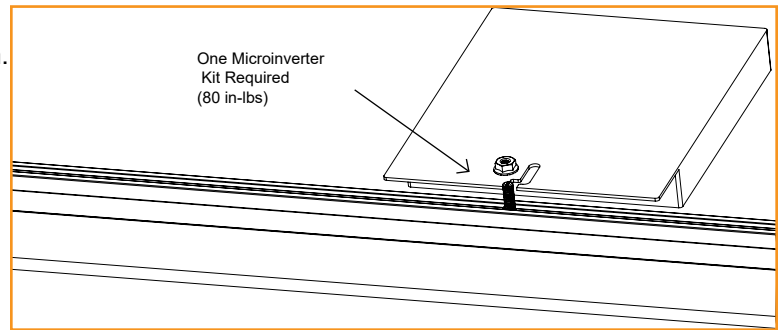

- Remove Grounding Washer on AP Systems QS1, QT2, DS3 and YC600 and Yotta inverters before installing to XR rails.
- Remove the Stainless Steel Clip on Tigo-"A" MLPE Devices before attaching to XR rails.
- Use the number of IronRidge Microinverter kits allowed by the MLPE mounting flange. Some will require 1 kit and others 2 kits.

SYSTEMS USING ENPHASE MICROINVERTERS OR SUNPOWER AC MODULES

IronRidge systems using approved Enphase products or SunPower modules eliminate the need for lay-in lugs and field installed equipment grounding conductors (EGC). This solution meets the requirements of UL 2703 for bonding and grounding and is included in this listing.

COMPATIBLE PRODUCTS

Sunpower

Modules with model identifier Ab-xxx-YY and InvisiMount (G5) 46mm frame; where "A" is either E, or X; "b" can be 17, 18, 19, 20, 21, or 22; and "YY" can be C-AC, D-AC, BLK-C-AC, or BLK-D-AC.

Enphase

Microinverters M250-72, M250-60, M215-60, C250-72, and Engage cables ETXX-240, ETXX-208, ETXX-277.

- A minimum of two inverters mounted to the same rail and connected to the same Engage cable are required.
- The microinverters or Sunpower AC modules must be used with a maximum 20 A branch rated overcurrent protection device (OCPD).
- If an AC module is removed from a circuit for maintenance, you must first disconnect AC power and then install a temporary EGC to bridge the gap by inserting an AC extension cable (or via other NEC-compliant means), in order to maintain effective ground continuity to subsequent modules.

SYSTEMS USING MICROSTORAGE PRODUCTS

Use IronRidge's Microinverter Kit to bond compatible microstorage devices to the racking system. Insert Microinverter Kit T-bolt into top rail slot. Place compatible microstorage into position and tighten hex nut to **80 in-lbs**.

COMPATIBLE PRODUCTS

PHAZR

PHAZR Devices PHAZR-X, where X is 6-12.

Solpad

Solpad Inverter model SI-1k

Solpad Battery Storage model SB-2K

Solpad Junction Box model SJB-4k

- Running a separate equipment grounding conductor to the PHAZR or Solpad devices is not required.
- If installing in areas with ground snow loads greater than 40 psf and underneath a module, install PHAZR and Solpad devices as close as possible to module frame edge.
- Solpad may only be installed on XR-100 and XR-1000
- Solpad may only be installed with modules having a frame thickness of 35mm or greater.
- Use the number of IronRidge Microinverter kits allowed by the microstorage mounting flange. Some will require 1 kit and others 2 kits.

PHAZR

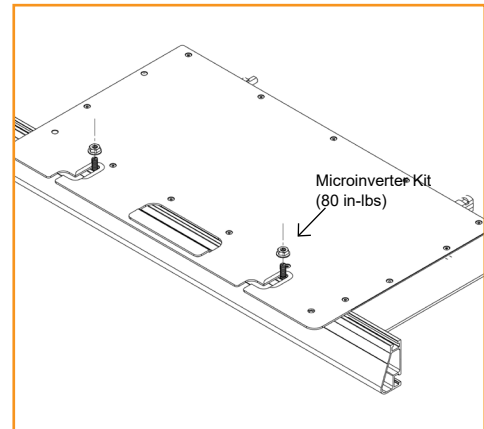

Solpad

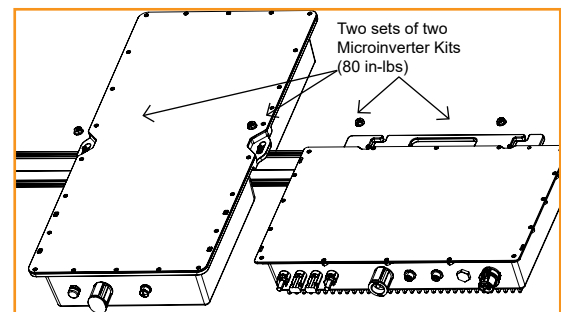

FRAMELESS MODULE KITS

Insert Frameless Kit T-bolt in top rail slot. Place star washer over T-bolt, allowing it to rest on top of rail. Secure module clamps with a hex nut and torque to **80 in-lbs**.

COMPATIBLE PRODUCTS

Sunforson

Sunforson silver or black SFS-UTMC-200(B) mid and SFS-UTEC-200(B) end clamps.

Sunpreme

Sunpreme silver or black mid and end clamps with part numbers 7500105X where "X" is 1, 5, 6 or 7.

Ironridge

IronRidge silver or black mid and end clamps with part numbers FMLS-XC-001-Y where "X" is E or M and "Y" is B or blank.

- Follow module manufacturer's installation instructions to install the module clamps.
- Frameless modules require using a Grounding Lug on every rail.
- For Sunpreme Modules Only: If required to use slide prevention hardware, see Module Slide Prevention Addendum (Version 1.10).

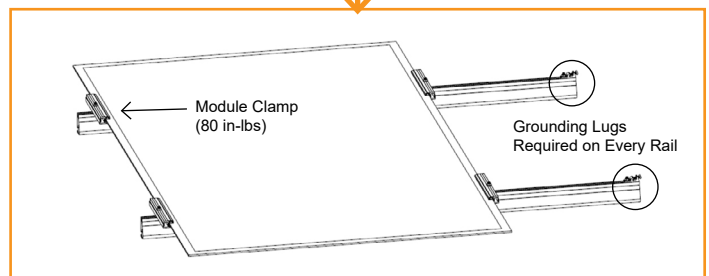
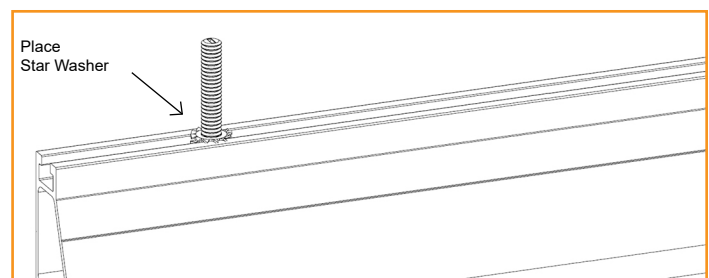

CONTOUR

Install Contour

Install Contour on a completed array.

A. Start by placing Contour Clamp on module frame within 12 inches of the down roof corner of the array. Each piece of 84" Contour Trim must be supported by two Clamps. Clamps must be installed in the 12" clamping zones at edge of trim. Once trim is placed and in position, secure trim by tightening Clamp set screw to **80 in-lbs**.

B. Multiple Contour pieces can be joined using Contour Splice. Install Splice on existing Contour edge and install Clamps in appropriate clamping zones for next piece of trim. Place trim on Clamps, slide into splice to join two pieces together. Secure Contour by tightening Clamp set screw to **80 in-lbs**. Repeat as needed across the array.

C. Cut trim to line up with edge of array.

D. Install Clamps within clamping zones on side of array. Install second Clamp as needed up array. Place Corner Cap on trim and slide side trim to align with Cap. Repeat as needed along roof for both inside and outside corners.

E. Use optional End Caps to cover any exposed edges of Contour as desired.

- Do not install on side of array facing roof peak.
- Contour can be installed with 1 clamp if trim section is 12" long (or shorter) and has a splice attached on one end, on which the section of trim the 12" section is spliced to also has 2 clamps.
- Contour Trim when installed when installed up roof requires the use of Aire Stealth Clamps.
- Wind Speed: no restrictions
- Ground Snow: up to 90 PSF

FRAME COMPATIBILITY

Contour Clamp has been tested or evaluated with all modules having frames within the referenced dimensions. Be sure the specific module being used meets the dimension requirements.

- Flange Thickness: 1-3.5mm
- Usable Flange Length: 0-33mm.

A.

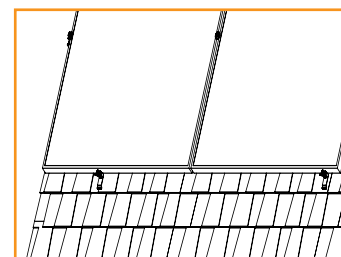
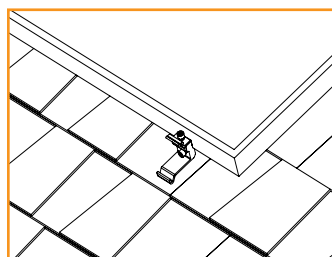
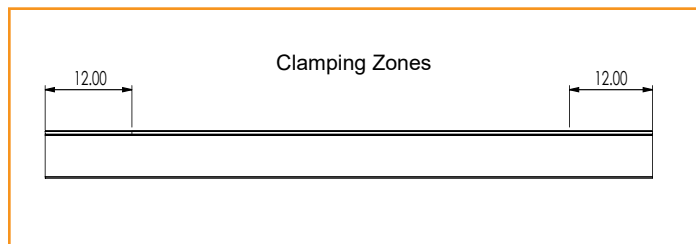

B.

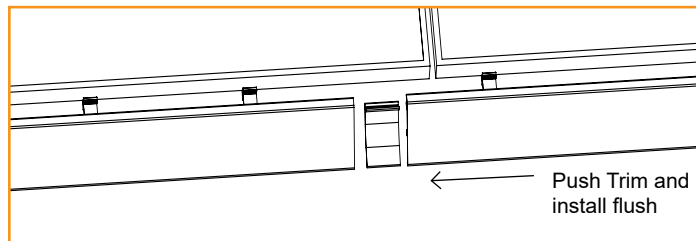

C.

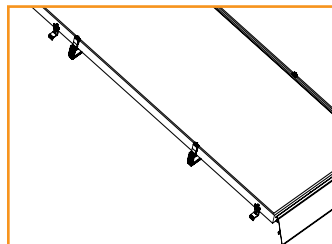

D.

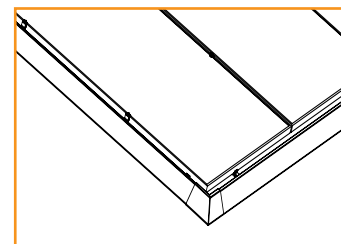

E.

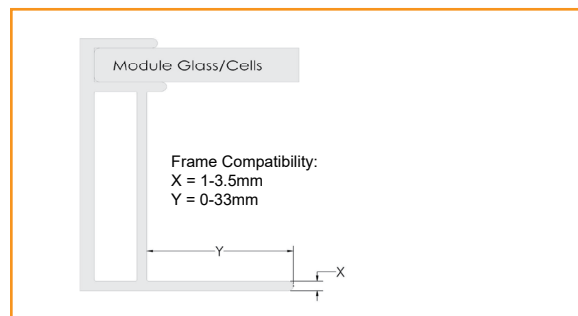
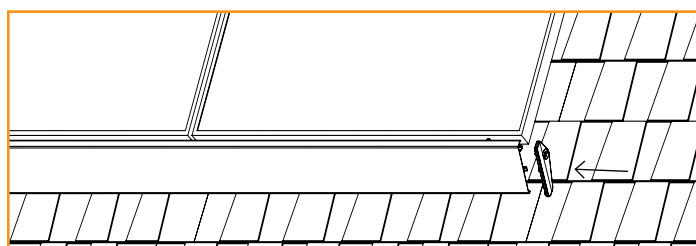

MODULE COMPATIBILITY

The Flush Mount System has been tested and evaluated to UL 2703 for bonding, grounding, mechanical loading and fire classification, and may be used to ground and/or mount PV modules listed to UL 1703 or UL 61730. A list of approved modules is included below. Unless otherwise noted, "xxx" refers to the module power rating and both black and silver frames are included in the certification.

FRAMED MODULE LIST

MAKE	MODELS
Adani	Adani modules with 30, 35 and 40 mm frames ASX-Y-ZZ-xxx Where "X" can be B, M or P; "Y" can be 6, 7 or M10 and "ZZ" can be blank, 144, PERC, B-PERC, or AB-PERC
AIONRISE	AIONRISE modules with 35 and 40 mm frames AIONyyG1-xxx Where "yy" can be 60 or 72
Amerisolar	Amerisolar modules with 35 and 40 mm frames AS-bYxxxZ Where "b" can be 5 or 6; "Y" can be M, P, M27, P27, M30, or P30; and "Z" can be blank, W or WB
Aptos Solar	Aptos modules with 35 and 40 mm frames DNA-yy-zzaa-xxx Where "yy" can be 108, 120 or 144; "zz" can be MF or BF; and "aa" can be 10, 23 or 26
Astronergy Solar	Astronergy modules with 30, 35 and 40 mm frames aaSMbbyyC/zz-xxx Where "aa" can be CH or A; "bb" can be 60, 66, or 72; "yy" can be blank, 10 or 12; "C" can M, P, M(BL), M-HC, M(BL)-HC, P-HC, M(DG), M(DGT) or N(DG); and "zz" can be blank, HV, F-B, or F-BH
ASUN	ASUN modules with 35 and 40 mm frames ASUN-xxx-YYZZ-aa Where "YY" can be 60 or 72; "ZZ" can be M, or MH5; and "aa" can be blank or BB
Auxin	Auxin modules with 35 and 40 mm frames AXNCyzAxxxB Where "C" can be 6, 10 or G1; "y" can be M or P; "z" can be blank, 08, 09, 610, 11, or 612; and "A" can be blank, F, M or T; and "B" can be blank, A, B, C or W
Axitec	Axitec Modules with 30, 35 and 40 mm frames AC-xxxY/aaZZb Where "Y" can be M, P, MB, MBT or MH; "aa" can be blank, 125- or 156-; "ZZ" can be 54, 60, 72, 108, 120, or 144; "b" can be S, X, V, VB, XV, or MX
Bluesun Solar	Bluesun modules with 30 and 35 mm frames BSMxxxY-AAA Where "Y" can be M or M10; and "AAA" can be 54HPH, 60HPH or 72HBD
Boviet	Boviet modules with 35 and 40 mm frames BVMZZaaYY-xxxBcc Where "ZZ" can be 66 or 76; "aa" can be 9, 10 or 12; "YY" is M or P; and "B" can be blank, L or S; and "cc" can be blank, H, H-BF, H-BF-DG, H-HC, H-HC-BF, H-HC-BF-DG, HC-BF or HC-BF-DG
BYD	BYD modules with 35 mm frames BYDxxxAY-ZZ Where "A" can be M6, P6, MH, MLT or PH; "Y" can be C or K; and "ZZ" can be 30 or 36
Canadian Solar	Canadian Solar modules with 30, 32, 35 and 40 mm frames CSbY-xxxZ Where "b" can be 1, 3, 6, 6.1 or 7; "Y" can be H, K, L, N, P, R, U, V, W, X, Y, -54TM or -72TB; and "Z" can be H, M, P, MS, PX, M-SD, P-AG, P-SD, MB-AG, PB-AG, MS-AG, MS-HL or MS-SD
CertainTeed	CertainTeed modules with 30, 35 and 40 mm frames CTBBxxxYZZ-AA Where "BB" can be blank or M10; "Y" can be M, P, or HC; "ZZ" can be 00, 01, 10, or 11; and "AA" can be 01, 02, 03, 04, 06, 08 or 09

MODULE COMPATIBILITY

Crossroads Solar	Crossroads Solar modules with 40 mm frames Crossroads Solar xxx
CSUN	Csun modules with 35 and 40 mm frames YYxxx-zzAbb Where "YY" is CSUN or SST; "zz" is blank, 60, or 72; and "A" is blank, P, M or MM; "bb" is blank, BB, 5BB, BW, or ROOF
Dehui	Dehui modules with 30, 35 and 40 mm frames DH-MYYYYZ-xxx Where "YYYY" can be 760, 772, 860, 872; and "Z" can be B, F or W
Ecosolargy	Ecosolargy modules with 35 and 40 mm frames ECOxxxYzzA-bbD Where "Y" can be A, H, S, or T; "zz" can be 125 or 156; "A" can be M or P; "bb" can be 60 or 72; and "D" can be blank or B
Emmvee	Emmvee modules with 35 mm frames Exxx-YYZZZ-A Where "YY" can be M, P, HCM, HCMW, HCBG, HCBT; "ZZZ" can be 72, 120 or 144; and "A" can be blank or B
ET Solar	ET Solar modules with 30, 35 and 40 mm frames ET-YZZZxxxAA Where "Y" can be P, L, or M; "ZZZ" can be 660, 660BH, 672, 672BH, 754BH, 766BH, 772BH; and "AA" can be GL, TB, TW, WB, WW, BB, WBG, WWG, WBAC, WBCO, WWCO, WWBCO or BBAC
Flex	Flex modules with 35 and 40 mm frames FXS-xxxYY-ZZ; Where "YY" can be BB or BC; and "ZZ" can be MAA1B, MAA1W, MAB1W, SAA1B, SAA1W, SAC1B, SAC1W, SAD1W, SBA1B, SBA1W, SBC1B, or SBC1W
Freedom Forever	Freedom Forever modules with 35 mm frames FF-MPa-BBB-xxx Where "a" can be blank or 1
Freevolt	Freevolt modules with 35 mm frames ECP-PVGRAF-144HC-xxx
GCL	GCL modules with 35 mm and 40 mm frames GCL-ab/YY xxx Where "a" can be M or P; "b" can be 3 or 6; and "YY" can be 60, 72, 72H, or 72DH
GigaWatt Solar	Gigawatt modules with 40 mm frames GWxxxYY Where "YY" can be either PB or MB
Goldi	Goldi modules with 35 mm frames GS10-Byyy-zz-xxx Where "yyy" can be 108 or 144; and "zz" can be GF or TF
Grape Solar	Grape modules with 35 mm frames GS-M120-xxx-FAB1
GreenWatts Solar	GreenWatts modules with 30 and 35mm frames HSYY-A-xxx-ZZ Where "YY" can be 54, 60, 66, 72 or 78; "A" can be blank or F; and "ZZ" can be MN or BOB
Hansol	Hansol modules with 35 and 40 mm frames HSxxxYY-zz Where "YY" can be PB, PD, PE, TB, TD, UB, UD, or UE; and "zz" can be AH2, AN1, AN3, AN4, HH2, HV1, or JH2
Hanwa Solar	Hanwha Solar modules with 40 mm frames HSLaaP6-YY-1-xxxZ Where "aa" can be either 60 or 72; "YY" can be PA or PB; and "Z" can be blank or B

MODULE COMPATIBILITY

Hanwha Q CELLS	<p>Hanwha Q CELLS Modules with 30, 32, 35, 40 mm frames aaYY-ZZ-xxx where "aa" can be Q. or B.; "YY" can be PLUS, PRO, PEAK, LINE PRO, LINE PLUS, PLUS DUO, PEAK DUO or TRON; and "ZZ" can be G3, G3.1, G4, G4.1, L-G2, L-G2.3, L-G3, L-G3.1, L-G3y, L-G4, L-G4.2, L-G4y, LG4.2/TAA, BFR-G3, BLK-G3, BFR-G3.1, BLK-G3.1, BFR-G4, BFR-G4.1, BFR G4.3, BLK-G4.1, G4/SC, G4.1/SC, G4.1/TAA, G4.1/MAX, BFR G4.1/TAA, BFR G4.1/MAX, BLK G4.1/TAA, BLK G4.1/SC, EC-G4.4, G5, G5/SC, G5/TS, BLK-G5, BLK-G5/SC, BLK-G5/TS, L-G5, L-G5.1, L-G5.2, L-G5.2/H, L-G5.3, G6, G6/SC, G6/TS, G6+/TS, G6+, BLK-G6, L-G6, L-G6.1, L-G6.2, L-G6.3, G7, BLK-G6+, BLK-G6+/AC, BLK-G6+/HL, BLK-G6+/SC, BLK-G6/TS, BLK-G6+/TS, BLK-G7, G7.2, G8, BLK-G8, G8+, BLK-G8+ L-G7, L-G7.1, L-G7.2, L-G7.3, L-G8, L-G8.1, L-G8.2, L-G8.3, L-G8.3/BFF, L-G8.3/BFG, L-G8.3/BGT, M-G2+, BLK M-G2+, ML-G9, BLK ML-G9, ML-G9+, BLK ML-G9+, BLK-G10, BLK-G10+, BLK G10+/AC, BLK-G10+/HL, ML-G10, BLK ML-G10, ML-G10+, BLK ML-G10+, ML-G10.a, BLK ML-G10.a, ML-G10.a+, BLK ML-G10.a+, BLK ML-G10 +/t, BLK ML-G10+/TS, XL-G2.3/BFG, XL-G9, XL-G9.2, XL-G9.3, XL-G9.3/BFG, XL-G10.2, XL-G10.3, XL-G10.c, XL-G10.d, XL-G10.d/BFG, XL-G10.3/BFG, XL-G11.2, XL-G11.3, XL-G11.3/BFG or XL-G11S.3/BFG</p>
Heliene	<p>Heliene modules with 35 and 40 mm frames YYZZxxxA Where "YY" can be 36, 60, 72, 96, 108, 120, 132, 144 or 156; "ZZ" can be HC, M, P, or MBLK; and "A" can be blank, HomePV, Bifacial, M10-SL, M10-SL-BLK, M10 TPC SL, M10 Bifacial, M10 SL-Bifacial or M10 TPC SL Bifacial</p>
HT-SAAE	<p>HT-SAAE modules with 35 and 40 mm frames HTyy-aaaZ-xxx Where "yy" can be 60, 66, 72 or 78, "aaa" can be 18, 156 or 166, "Z" can be M, P, M-C, P-C, M(S), M(VS), M(V), P(V), M(V)-C, P(V)-C, or X</p>
Hyperion Solar (Runergy)	<p>Hyperion modules with 30 and 35 mm frames HY-DHzzzA8-xxxB Where "zzz" can be 108 or 144; "A" can be N or P; and "B" can be blank or B</p>
Hyundai	<p>Hyundai modules with 32, 33, 35 and 40 mm frames HiY-SxxxZZ Where "Y" can be A, D or S; "S" can be M or S; and "ZZ" can be GI, HG, HI, KI, MI, MF, MG, PI, RI, RG, RG(BF), RG(BK), SG, TI, TG, YH(BK) or XG(BK)</p>
Itek	<p>Itek Modules with 40 mm frames IT-xxx-YY Where "YY" can be blank, HE, or SE, or SE72</p>
JA Solar	<p>JA Solar modules with 30, 35 and 40 mm frames JAyyzz-bbww-xxx/aa Where "yy" can be M, P, M6 or P6; "zz" can be blank, (K), (L), (R), (V), (BK), (FA), (TG), (FA)(R), (L)(BK), (L)(TG), (R)(BK), (R)(TG), (V)(BK), (BK)(TG), or (L)(BK)(TG); "bb" can be 48, 54, 60, 66, 72 or 78; "ww" can be D09, D10, D20, D30, S01, S02, S03, S06, S09, S10, S12, S17, S20, S30 or S31; and "aa" can be BP, MB, MR, SI, SC, PR, 3BB, 4BB, 4BB/RE, 5BB</p>
Jinko	<p>Jinko modules with 30, 35 and 40 mm frames JKMYxxxZZ-aa Where "Y" can either be blank or S; "ZZ" can be M, N, P, or PP; and "aa" can be blank, 54HL4-B, 60, 60B, 60H, 60L, 60BL, 60HL, 60HB, 60HBL, 6HBL-EP, 60-J4, 60B-J4, 60B-EP, 60(Plus), 60-V, 60-MX, 6RL3, 6RL3-B, 6TL3-B, 7RL3-V, 7RL3-TV, 72, 72B, 72-J4, 72B-J4, 72(Plus), 72-V, 72H-V, 72L-V, 72HL-V, 72HBL-V, 72HL4-V, 72HL4-BDV, 72HL4-TV, 72-MX, 72H-BDVP, 72HL-TV, or 72HL-V-MX3</p>
KB Solar	<p>KB Solar modules with 35 mm frames KBS-xxx-Mono-YY Where "YY" can be blank or BF</p>
Kyocera	<p>Kyocera Modules KYxxxZZ-AA Where "Y" can be D or U; "ZZ" can be blank, GX, or SX; and "AA" can be LPU, LFU, UPU, LPS, LPB, LFB, LFBS, LFB2, LPB2, 3AC, 3BC, 3FC, 4AC, 4BC, 4FC, 4UC, 5AC, 5BC, 5FC, 5UC, 6BC, 6FC, 8BC, 6MCA, or 6MPA</p>
LA Solar	<p>LA Solar modules with 35 mm frames LSxxxYY Where "YY" can be BF, BL, BLA, HC or ST</p>

MODULE COMPATIBILITY

LG	<p>LG modules with 35 and 40 mm frames LGxxxYaZ-bb Where "Y" can be A, E, M, N, Q, S; "a" can be A, 1, 2 or 3 "Z" can be C, K, T, or W; and "bb" can be A3, A5, A6, B3, B6, E6, E6.AW5, G3, G4, J5, K4, L5, N5, V5, V6</p>
Longi	<p>Longi modules with 30, 35 and 40 mm frames LRa-YYZZ-xxxM Where "a" can be 4, 5 or 6; "YY" can be blank, 54, 60, 66, or 72; and "ZZ" can be blank, BK, BP, HV, PB, PE, PH, HBD, HIB, HIH, HPB, HPH, HIBD, HABB or HABD</p>
Maxeon	<p>Maxeon modules with 35, 40 and 46 mm frames SPR-AAAY-xxx-zzz Where "AAA" can be MAX, P or X; "Y" can be 3, 5, 6, 21 or 22; and "zzz" can be R, BLK, BLK-R, COM or UPP</p>
Meyer Burger	<p>Meyer Burger Modules with 35 mm frames Meyer Burger Black, White or Glass</p>
Mission Solar (mSolar)	<p>Mission Solar modules with 33, 35 and 40 mm frames YYYbb-xxxZZaa Where "YYY" can be MSE, TXI or TXS; "bb" can be blank, 6, 10 or 60A; "ZZ" can be blank, HT, MM, SE, SO, SQ, SR, SX, TS, 108, 120 or 144; and "aa" can be blank, 0B, 2B, BB, BW, 1J, 4J, 4S, 5K, 5R, 5T, 60, 6J, 6S, 6W, 6Z, 8K, 8T, 9R, 9S or 9Z</p>
Mitrex	<p>Mitrex modules with 30 and 40 mm frames Mxxx-XYZ Where "X" can be A, B, I or L; "Y" can be 1 or 3; and "Z" can be F or H</p>
Mitsubishi	<p>Mitsubishi modules PV-MYYxxxZZ Where "YY" can be LE or JE; and "ZZ" can be either HD, HD2, or FB</p>
Moltech	<p>IM and XS series modules with 40 mm frames</p>
Navitas	<p>Navitas Modules with 35 mm frames NSMxxx-yyy Where "yyy" can be 120, 132 or 144</p>
Next Energy Alliance	<p>Next Energy Alliance modules with 35 and 40 mm frames yyNEA-xxxZZ where "yy" can be blank or US; "ZZ" can be M, MB or M-60</p>
NE Solar	<p>NE Solar modules with 30, 35 and 40 mm frames NESExxx-zzMHX-yy Where "zz" can be 54, 60 or 72; "X" can be blank or B; and "yy" can be M6 or M10</p>
Neo Solar Power	<p>Neo Solar Power modules with 35 mm frames D6YxxxZZaa Where "Y" can be M or P; "ZZ" can be B3A, B4A, E3A, E4A, H3A, H4A; and "aa" can be blank, (TF), ME or ME (TF)</p>
Panasonic (HIT)	<p>Panasonic modules with 35 and 40 mm frames VBHNxxxYYzza Where "YY" can be either KA, RA, SA or ZA; "zz" can be either 01, 02, 03, 04, 06, 06B, 11, 11B, 15, 15B, 16, 16B, 17, or 18; and "A" can be blank, E, G, or N</p>
Panasonic (EverVolt)	<p>Panasonic modules with 30 mm frames EVPVxxxA Where "A" can be blank or H, K, HK or PK</p>
Peimar	<p>Peimar modules with 40 mm frames SbxxxYzz Where "b" can be G, M or P; "Y" can be M or P; and "zz" can be blank, (BF) or (FB)</p>
Philadelphia Solar	<p>Philadelphia modules with 30, 35 and 40 mm frames PS-YzzAA-xxxW Where "Y" can be M or P; "zz" can be 60, 72, 108 or 144; "AA" can be blank, (BF), (HC) or (HCBF); and "W" can be blank or W</p>

MODULE COMPATIBILITY

Phono Solar	Phono Solar modules with 30, 35 and 40 mm frames PSxxxY-ZZ/A Where "Y" can be M, M1, MH, M1H, M4, M4H, M5GF, M5GFH, M6, M6H, M8, M8H, M8GF, M8GFH or P; "ZZ" can be 18, 20 or 24; and "A" can be F, T, TH, THB, U, UH, UHB, VH or VHB
Prism Solar	Prism Solar modules with 35 mm frames PST-xxxW-M72Y Where "Y" can be H, HB or HBI
Rayzon Solar	Rayzon Solar modules with 35 and 40 mm frames RSxxxWC
Recom	Recom modules with 35 and 40 mm frames RCM-xxx-6yy Where "yy" can be MA, MB, ME or MF
REC Solar	REC modules with 30 and 38 mm frames RECxxxYYZZ Where "YY" can be AA, M, NP, NP2, NP3, PE, PE72, TP, TP2, TP2M, TP2SM, TP2S, TP3M or TP4; and "ZZ" can be blank, Black, BLK, BLK2, SLV, 72, Pure, Pure-R, Pure-RX or Pure 2
Renesola	ReneSola modules with 35 and 40 mm frames AAxxxY-ZZ Where "AA" can be SPM(SLP) or JC; "Y" can be blank, F, M or S; and "ZZ" can be blank, Ab, Ab-b, Abh, Abh-b, Abv, Abv-b, Bb, Bb-b, Bbh, Bbh-b, Bbv, Bbv-b, Db, Db-b, or 24/Bb
Renogy	Renogy Modules with 35 and 40 mm frames RZZ-xxxY-AAA Where "ZZ" can be NG or SP; "Y" can be D or P; and "AAA" can be blank, 144, BB-108, BB-120 or BK-120
Risen	Risen Modules with 30, 35 and 40 mm frames RSMyy-a-xxxZZ Where "yy" can be 60, 72, 110, 120, 132 or 144; "a" can be 6, 7 or 8; and "ZZ" can be M, P or BMDG
Saatvik	Saatvik Modules with 35 mm frames SGExxx-YYYZZZ Where "YYY" can be 108 or 144; and "ZZZ" can be MHC, MBHC or MHCB
S-Energy	S-Energy modules with 35 and 40 mm frames SABB-CCYYY-xxxZ Where "A" can be C, D, L or N; "BB" can be blank, 20, 25, 40 or 45; "CC" can be blank, 60 or 72; "YYY" can be blank, BDE, MAE, MAI, MBE, MBI, MCE or MCI; and "Z" can be V, M-10, P-10 or P-15
SEG Solar	SEG Solar with 30, 35 and 40 mm frames SEG-aYY-xxxZZ Where "a" can be blank, 6 or B; "YY" can be blank, MA, MB, PA, or PB; and "ZZ" can be blank, BB, BG, BW, HV, WB, WW, BMB, BMA-HV, BMA-BG, BMA-TB, BMB-TB, BMB-HV, BMD-HV, BMB-BG, BTA-BG or BMD-TB
Seraphim USA	Seraphim modules with 30, 35 and 40 mm frames SRP-xxx-YYY-ZZ Where "xxx" is the module power rating; and "YYY" can be BMA, BMD, 6MA, 6MB, 6PA, 6PB, 6QA-XX-XX, and 6QB-XX-XX; ZZ is blank, BB, BG or HV
Sharp	Sharp modules with 35 and 40 mm frames NUYyxxx Where "YY" can be SA or SC
Shinsung E&G	Shinsung Modules with 35 mm frames SSVxxx-144MH
Silfab	Silfab Modules with 35 and 38 mm frames SYY-Z-xxxAb Where "YY" can be IL, SA, LA, SG or LG; "Z" can be blank, M, P, or X; "A" can be blank, B, H, M, N or Q; and "b" can be A, C, C+, D, G, K, L, M, N, T, U or X

MODULE COMPATIBILITY

Sirius PV	Sirius PV Modules with 35 mm frames ELNSMzzM-HC-xxx Where "zz" can be 54 or 72
Solar4America	Solar4America modules with 30, 35 and 40 mm frames S4Axxx-YYzzAA Where "YY" can be 60, 72, 108 or 144; "zz" can be MH5 or MH10; and "AA" can be blank or BB, BW, SW or STT
Solarever	Solarever modules with 35 mm frames SE-zzz*yy-xxxM-aaa Where "zzz" can be 166 or 182; "yy" can be 83 or 91; and "aaa" can be 108, 144 or 144N
Solaria	Solaria modules with 35 and 40 mm frames PowerA-xxxY-ZZ Where "A" can be X or XT, "Y" can be R or C; and "ZZ" can be blank, AC, BD, BX, BY, PD, PL, PM, PM-AC, PX, PZ, WX, WZ or 4T
Solarcity (Tesla)	Solarcity modules with 40 mm frames SCxxxYY Where "YY" can be blank, B1 or B2
SolarTech	SolarTech modules with 40 mm frames AAA-xxxYY Where "AAA" can be PERCB-B, PERCB-W, HJT B-B, HJT B-W or STU; "YY" can be blank, PERC or HJT
SolarWorld AG	SolarWorld Sunmodule Plus, Protect, Bisun, XL, Bisun XL, may be followed by mono, poly, duo, black, bk, or clear; modules with 31 and 33 mm frames SW-xxx
SolarWorld Americas	SolarWorld Sunmodule Plus, Protect, Bisun, XL, Bisun XL, may be followed by mono, poly, duo, black, bk, or clear; modules with 33 mm frames SWA-xxx
Sonali	Sonali Modules with 35 and 40 mm frames SS-M-xxx Where "M" can be blank or M
Star Solar	Star Solar modules with 35 mm frames Star-xxxW-YYY-ZZZ Where "YYY" can be M60H or M60HB; and "ZZZ" can be blank or M10
Stion	Stion Thin film modules with 35 mm frames STO-xxx or STO-xxxA
SunEdison	SunEdison Modules with 35 and 40 mm frames SE-YxxxZABCDE Where "Y" can be B, F, H, P, R, or Z; "Z" can be 0 or 4; "A" can be B,C,D,E,H,I,J,K,L,M, or N ; "B" can be B or W; "C" can be A or C; "D" can be 3, 7, 8, or 9; and "E" can be 0, 1 or 2
Suniva	Suniva modules with 35, 38 and 40 mm frames OPTxxx-AA-B-YYY-Z MVXxxx-AA-B-YYY-Z Where "AA" is either 60 or 72; "B" is either 4 or 5; "YYY" is either 100,101,700,1B0, or 1B1; and "Z" is blank or B
Sunmac Solar	Sunmac modules with 30 and 35 mm frames SMxxxMaaaZZ-YY Where "aaa" can be 660, 754 or 772; "ZZ" can be NH or SH; and "YY" can be BB or TB
Sunpower	Sunpower standard (G3 or G4) or InvisiMount (G5) 35 and 40 mm frames SPR-Zb-xxx-YY Where "Z" can be A, E, M, P or X; "b" can be blank, 17, 18, 19, 20, 21, or 22; and "YY" can be blank, BLK, COM, C-AC, D-AC, E-AC, BLK-E-AC, G-AC, BLK-G-AC, H-AC, BLK-H-AC, BLK-C-AC, or BLK-D-AC

MODULE COMPATIBILITY

Sunspark	Sunspark modules with 40 mm frames SYY-xxxZ-A Where "YY" can be MX or ST; and "Z" can be M, MB, M3, M3B, P or W; and "A" can be 60 or 72
Suntech	Suntech modules with 35 and 40 mm frames STPxxxz-aa Where "y" is blank or S; and "zz" can be 20, 24, A60, A72U, B60 or B72; and "aa" can be Vd, Vem, Vfw, Vfh, Vnh, Wdb, Wde, Wd, Wfhh or Wnhb
Talesun	Talesun modules with 30, 35 and 40 mm frames TAByZZaa-xxx-b Where "A" can be D or P; "B" can be 6 or 7; "y" can be blank, F, G, H, I or L; "ZZ" can be 54, 60, 66, 72 or 78; "aa" can be M, M(H), or P; and "b" can be blank, B, T, or (H)
Tesla	Tesla modules with 40 mm frames TxxxY Where "Y" can be H or S
Thornova	Thornova Modules with 30 and 35 mm frames TS-YYZZ(xxx)-X Where "YY" can be BB, BG or BGT; "ZZ" can be 54, 60 or 72; and "X" can be blank or X
Trina	Trina Modules with 30, 35 and 40 mm frames TSM-xxxYYZZ Where "YY" can be DD05, DD06, DD14, DE14, DE15, DE15V, DEG15, DEG15VC, DE18M, DEG18MC, DE09, DE19, DEG19C.20, DE06X, PA05, PC05, PD05, PD06, PA14, PC14, PD14, PE14, PE15, NEG19RC or NE09RC ; and "ZZ" can be blank, .05, .05(II), .08, .08(II), .10, .18, .08D, .18D, 0.82, .002, .00S, 05S, 08S, .20, .20(II), A, A.05, A.08, A.10, A.18, (II), A(II), A.05(II), A.08(II), A.082(II), A.10(II), A.18(II), C.05, C.07, C.05(II), C.07(II), H, H(II), H.05(II), H.08(II), HC.20(II), HC.20(II), M, M(II), M.05(II), MC.20(II)
Universal	Universal Solar modules with 35 mm frames UNI-xxx-yyyZZZ-aa Where "yyy" can be 108, 120 or 144; "ZZZ" can be M, MH, BMH; and "aa" can be blank, BB or DG
URE	URE modules with 35 mm frames DyZxxxxaa Where "D" can be D or F, "y" can be A, B, 6 or 7; "Z" can be K, L or M; and "aa" can be C8G, H3A, H4A, H8A, L4A, E7G-BB, E8G, E8G-BB, MFG, MFG-BB or M7G-BB
Vikram	Vikram solar modules with 35 and 40 mm frames XVSyy.ZZ.AAA.bb Where "X" can be blank, Paradea, Prexos or Somera; "yy" can be M, P, MBB, MDH, MDHT, MH, MS, MHBB, or PBB; "ZZ" can be 54, 60 or 72; "AAA" is the module power rating; and "bb" can be 03, 04 or 05
VSUN	VSUN modules with 30, 35 and 40 mm frames VSUNxxxA-YYz-aa Where "A" can be blank or N; "YY" can be 60, 72, 108, 120, 132, 144; "z" can be M, P, MH, PH, or BMH; and "aa" can be blank, BB, BW, or DG
Waaree	Waaree modules with 35 and 40 mm frames AAyy-xxx Where "AA" can be WS or Bi; and "yy" can be blank, M, MB, MD, MDI, MDIB, 33, 55, 57 or 66
Winaico	Winaico modules with 35 and 40 mm frames Wsy-xxxZa Where "y" can be either P or T; "Z" can be either M, P, or MX; and "a" can be blank or 6

MODULE COMPATIBILITY

Yingli	Yingli modules with 30, 35 and 40 mm frames YLxxxZ-yy Where "Z" can be D or P; "yy" can be blank, 29b, 30b, 34d, 35b, 36b, 37e 1/2, 37e 1500V 1/2, 40d, 49e 1/2 or 49e 1500V 1/2
Yotta	Yotta modules with 30 and 35 mm frames YSM-Bxxx-ZZ-72-1 Where "ZZ" can be 06 or 10
Zeus	Zeus Solar Modules with 40 mm frames ZxxxM-HB
ZN Shine	ZN Shine modules with 30 and 35 mm frames ZXY-AAA-xxx/M Where "Y" can be 6, 7 or 8; "AAA" can be 72, NH120, NH144, NHDB144, NHLDD144, SH108, SH144, SHDB144, SHLDD144, TP120 or UHLDD144; and "M" can be M or N

MODULE COMPATIBILITY

FRAMELESS MODULE LIST

MAKE	MODELS
Astronergy Solar	Astronergy frameless modules CHSM6610P(DG)-xxx
Canadian Solar	Canadian Solar frameless modules CSbY-xxx-Z Where "b" can be 3 or 6; "Y" is K, P, U, or X; and "Z" can be M-FG, MS-FG, P-FG, MB-FG, or PB-FG
Heliene	Heliene frameless modules YYZZxxxA Where "YY" can be 72; "ZZ" can be M; and "A" can be GH
Jinko	Jinko frameless modules JKMxxxPP-DV
Prism Solar	Prism Solar frameless modules BZYY-xxxAAA Where "Z" can be i or N; "YY" can be 48, 60, 60S, 72 or 72S; and "AAA" can be blank or BSTC
Risen	Risen frameless modules RSMyy-6-xxxZZ Where "yy" can be 60, 72, 120 or 144; and "ZZ" can be MDG or PDG
Stion	Stion frameless modules STL-xxx or STL-xxxA
Sunpreme	Sunpreme frameless modules GXB-xxxYY Where "YY" can be blank or SL
Trina	Trina frameless modules TSM-xxxYY Where "YY" can be either DEG5(II), DEG5.07(II), DEG5.40(II), DEG5.47(II), DEG14(II), DEG14C(II), DEG14C.07(II), DEG14.40(II), PEG5, PEG5.07, PEG5.40, PEG5.47, PEG14, or PEG14.40