

## SCOPE OF WORK

TO INSTALL A SOLAR PHOTOVOLTAIC (PV) SYSTEM AT THE RIGGSBEE RESIDENCE, LOCATED AT 10 BRADDOCK DRIVE, LILLINGTON, NORTH CAROLINA. THE POWER GENERATED BY THE PV SYSTEM WILL BE INTERCONNECTED WITH THE UTILITY GRID THROUGH THE NEW ELECTRICAL SERVICE EQUIPMENT. THE PV SYSTEM DOES INCLUDE STORAGE BATTERIES.

## SYSTEM RATING

10.200 kW DC STC  
9.216 kW AC

## EQUIPMENT SUMMARY

- (24) SUNPOWER SPR-M425-H-AC (425W) PV MODULES
- TYPE H MODULE-INTEGRATED MICRO-INVERTERS: ENPHASE
- (24) IQ7HS-66-M-US[240V] PV INVERTERS

## SHEET INDEX

- PV-0 COVER
- PV-1 SITE MAP AND PV LAYOUT
- PV1A RACKING PLAN
- PV-2 STRING MAP AND MONITORING LAYOUT
- PV-3 ELECTRICAL DIAGRAM
- PV-4 EQ WALL
- PV-5 MOUNTING DETAIL
- PV-6 SYSTEM LABELING DETAIL
- PV-7 SITE DIRECTORY PLACARD
- PV-8 SAFETY PLAN

## GOVERNING CODES

2017 NATIONAL ELECTRICAL CODE  
2018 NORTH CAROLINA RESIDENTIAL CODE  
2018 NORTH CAROLINA STATE BUILDING CODE  
UNDERWRITERS LABORATORIES (UL) STANDARDS  
OSHA 29 CFR 1910.269

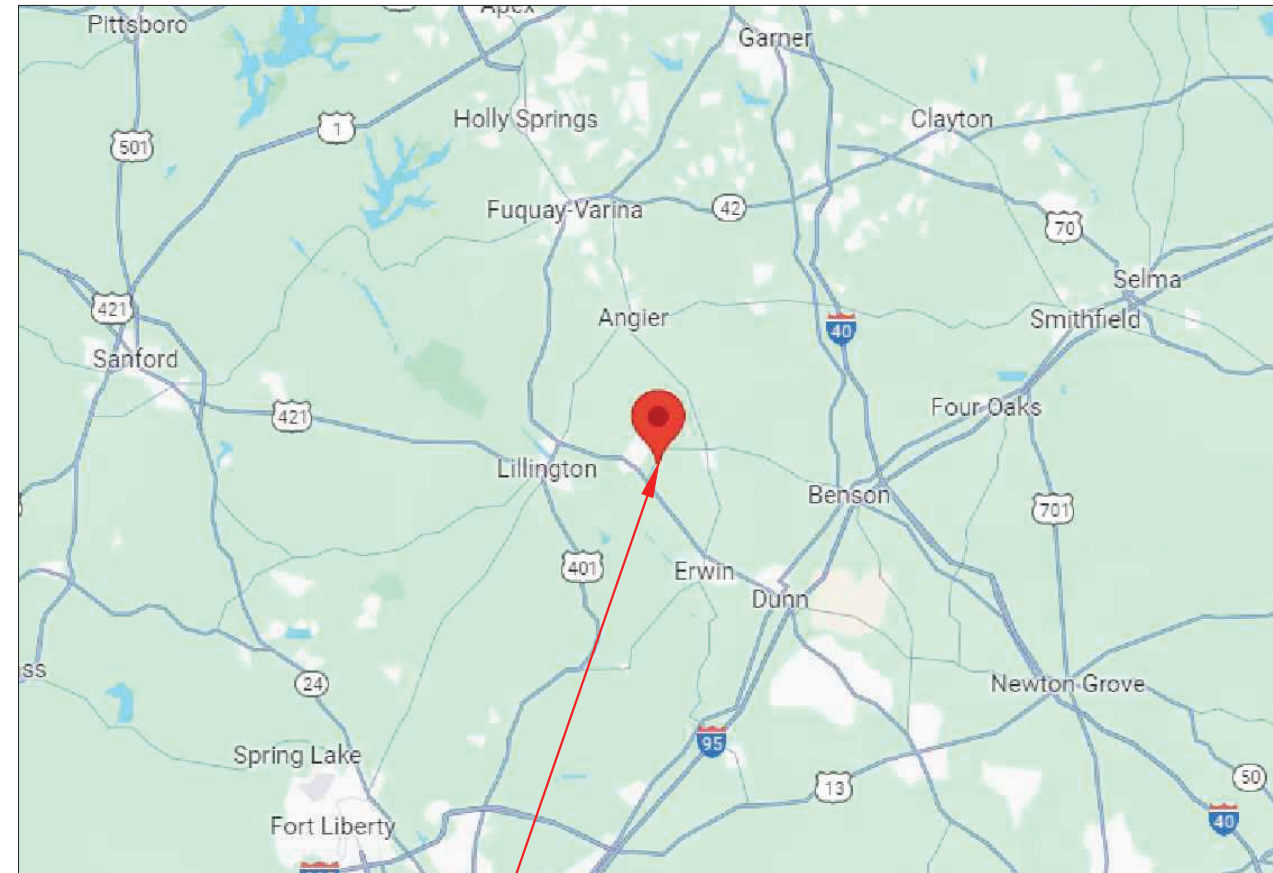

PROJECT LOCATION

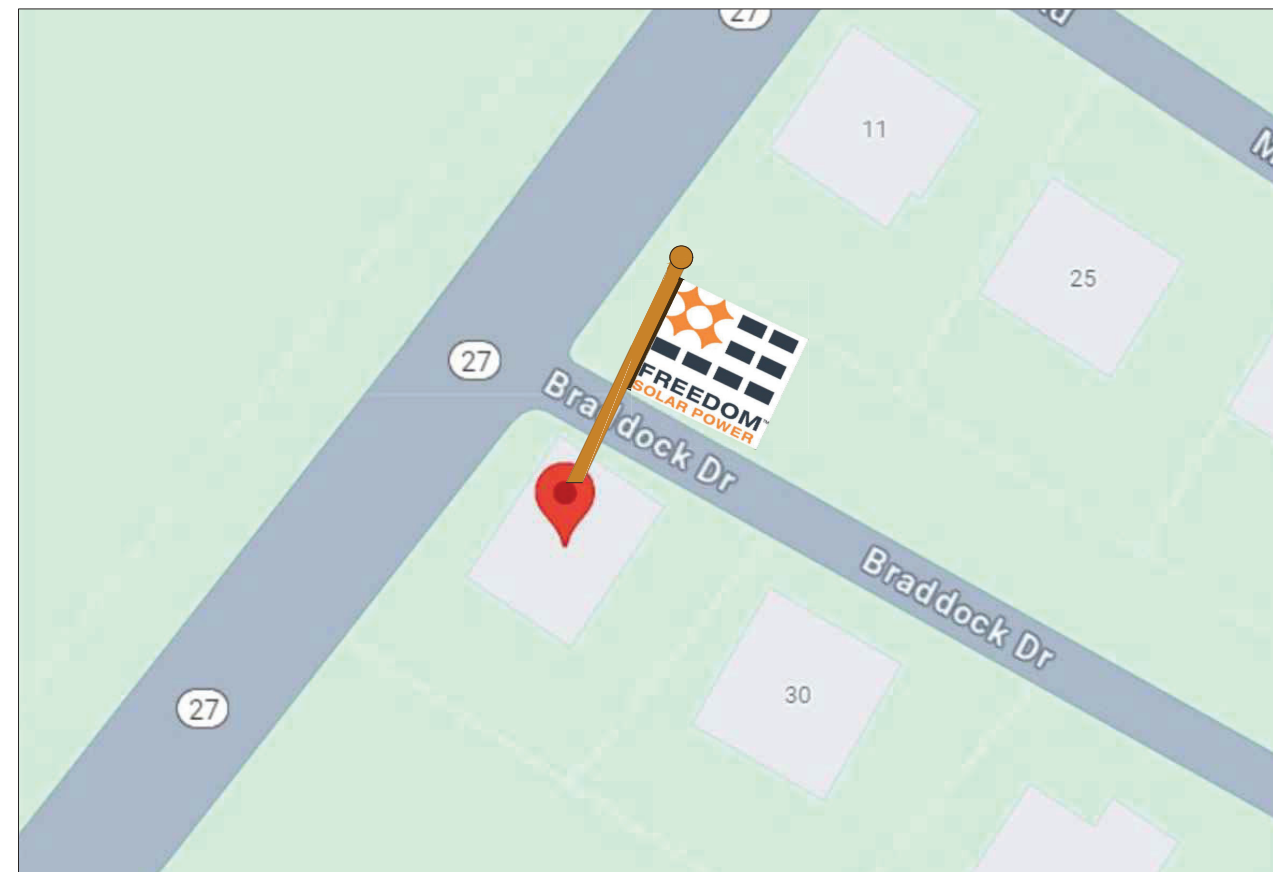

VICINITY MAP

CONTRACTOR



**FREEDOM<sup>TM</sup>**  
**SOLAR POWER**

FREEDOM SOLAR LLC  
4801 FREDRICH LN, STE 100  
AUSTIN, TX 78744  
512-759-8313  
TECL # 28621

REVISIONS		
DESCRIPTION	DATE	REV
DESIGN PACKET	07/03/2024	-

PE STAMP

PROJECT NAME

**BILLY H RIGGSBEE**  
**10 BRADDOCK DRIVE**  
**LILLINGTON, NORTH**  
**CAROLINA, 27546**

(910) 658-7865  
PROJECT ID: 114862

SHEET NAME

**COVER**

SHEET SIZE

**ANSI B**  
**11" x 17"**

SHEET NUMBER

**PV-0**



LEAD ID: 114862

**CONSTRUCTION SUMMARY**

- (24) (SUNPOWER SPR-M425-H-AC (425W)) SOLAR MODULES, 10.200 kW DC STC  
MODULE DIMENSIONS = 40.6" X 73.7" X 1.57"
- (24) TYPE H MODULE-INTEGRATED MICRO-INVERTERS: ENPHASE IQ7HS-66-M-US[240V] PV INVERTERS  
COMBINED INVERTER OUTPUT = 9.216 kW AC.

- RACKING: SUNPOWER CLASSIC INVISIMOUNT
- ATTACHMENT: PEGASUS INSTAFLASH
- (01) SUNPOWER MONITORING
  - (1) GENERATION PANEL
  - (1) TESLA POWERWALL 3 1707000-XX-Y [240V] PVINVERTER

**SITE DETAILS**

ROOF TYPE: ASPHALT SHINGLE  
 ARRAY #1 - TILT = 30°, AZIMUTH = 214°  
 ARRAY #2 - TILT = 16°, AZIMUTH = 214°

PV ARRAY #1  
(17) MODULES

PV ARRAY #2  
(07) MODULES

SUB PANEL  
(INSIDE GARAGE WALL)

DUKE ENERGY REVENUE METER  
 #332 283 546  
 GROUNDING ELECTRODE  
 TESLA ENERGY GATEWAY  
 MAIN DISTRIBUTION PANEL  
 GENERATION PANEL  
 SUNPOWER MONITORING  
 PV AC DISCONNECT  
 -VISIBLE  
 -LOCKABLE  
 -LABELED  
 -KNIFE BLADE DISCONNECT  
 (OUTSIDE HOUSE WALL)

(1)TESLA POWERWALL 3  
1707000-XX-Y [240V] PV INVERTERS  
(OUTSIDE HOUSE WALL)

NOTE : PE STAMPS REQUIRED IF:  
 -WEIGHT OF ARRAY IS >3PSF  
 -MORE THAN 1-LAYER OF SHINGLE  
 -ROOF TYPE IS OTHER THAN COMP SHINGLES  
 -WIND SPEED IS GREATER THAN 140 MPH  
 IF DESIGN PACK IS NOT STAMPED, MUST INCLUDE  
 EXCEPTION STATEMENT IN RED:

-PANEL WEIGHT EQUALS 2.5 LBS PER SQ FT,  
 LESS THAN 3 LBS PER SQ FT

**NO CUTTING AND COVERING PLUMBING VENTS AT ALL,  
 PVC PIPES CAN BE RELOCATED WITH ROOF JACK**

**FALL PROTECTION REQUIRED**

**CONSTRUCTION NOTES**

- 1.) ALL EQUIPMENT SHALL BE INSTALLED IN ACCORDANCE WITH THE MANUFACTURER'S INSTALLATION INSTRUCTIONS.
- 2.) ALL OUTDOOR EQUIPMENT SHALL BE RAIN-TIGHT WITH MINIMUM NEMA 3R RATING.
- 3.) ALL LOCATIONS ARE APPROXIMATE AND REQUIRE FIELD VERIFICATION.

**UTILITY SHUTDOWN REQUIRED TO  
 PERFORM A FULL SERVICE REBUILD.**



CONTRACTOR

**FREEDOM™  
SOLAR POWER**

FREEDOM SOLAR LLC  
 4801 FREDRICH LN, STE 100  
 AUSTIN, TX 78744  
 512-759-8313  
 TECL # 28621

REVISIONS

DESCRIPTION	DATE	REV
DESIGN PACKET	07/03/2024	-

PE STAMP

PROJECT NAME

**BILLY H RIGGSBEE**  
**10 BRADDOCK DRIVE**  
**LILLINGTON, NORTH**  
**CAROLINA, 27546**

(910) 658-7865  
 PROJECT ID: 114862

SHEET NAME

**SITE MAP &  
PV LAYOUT**

SHEET SIZE

**ANSI B  
11" x 17"**

SHEET NUMBER

**PV-1**





CONTRACTOR

**FREEDOM<sup>TM</sup>  
SOLAR POWER**

FREEDOM SOLAR LLC  
4801 FREDRICH LN, STE 100  
AUSTIN, TX 78744  
512-759-8313  
TECL # 28621

REVISIONS		
DESCRIPTION	DATE	REV
DESIGN PACKET	07/03/2024	-

PE STAMP

PROJECT NAME

**BILLY H RIGGSBEE  
10 BRADDOCK DRIVE  
LILLINGTON, NORTH  
CAROLINA, 27546**

(910) 658-7865  
PROJECT ID: 114862

SHEET NAME

**RACKING PLAN**

SHEET SIZE

**ANSI B  
11" x 17"**

SHEET NUMBER

**PV-1A**

PEGASUS INSTAFLASH BLACK,  
5/16" X 4.0" SS LAG WITH MIN.  
2.5" EMBEDMENT INTO THE RAFTERS  
AT MAX 48" O.C. ALONG RAILS

2"X4" MANUFACTURED  
TRUSSES AT 24" O.C. TYP.

(2) RAILS PER ROW OF  
MODULES EVENLY SPACED

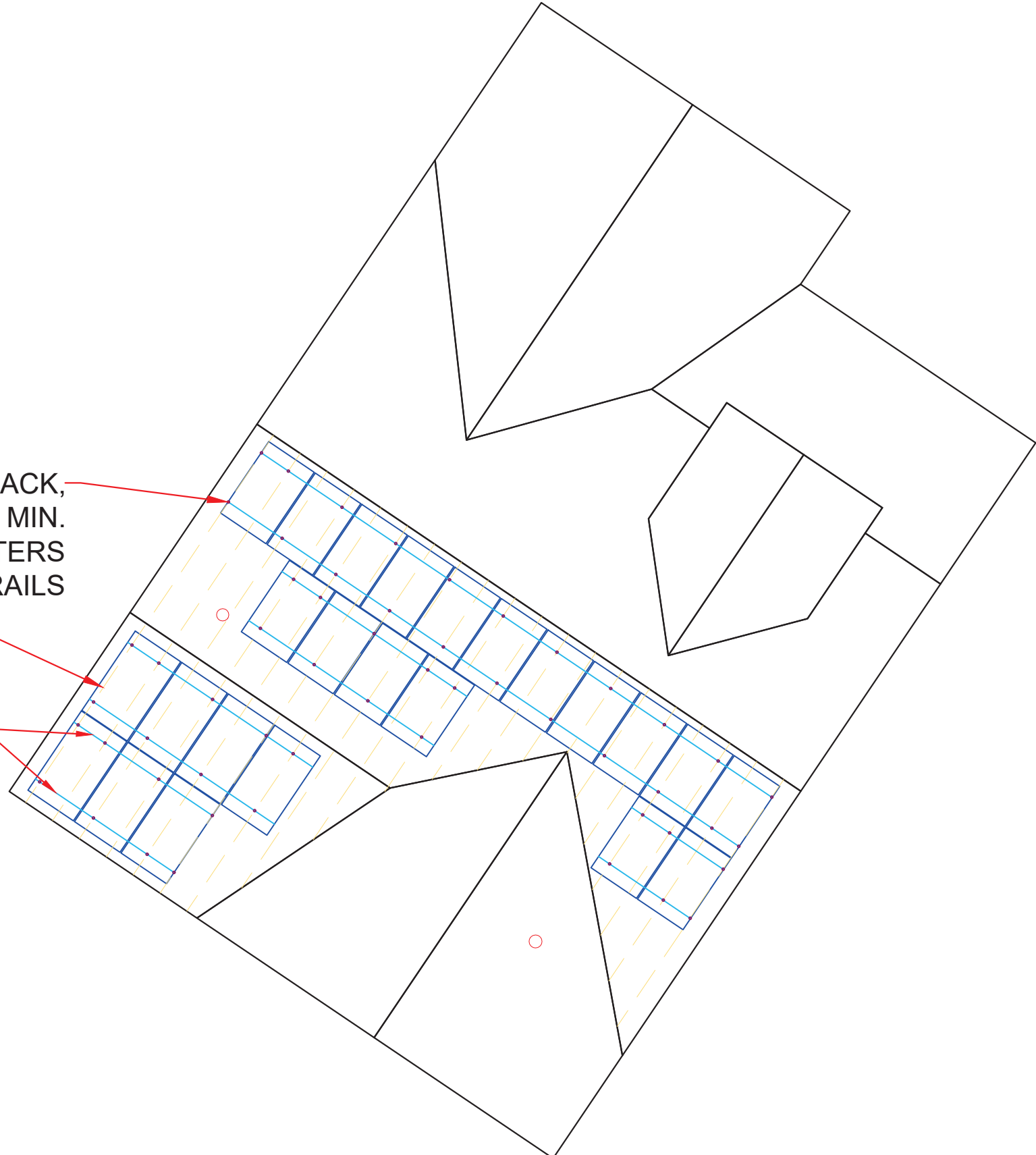

**CONSTRUCTION NOTES**

- 1.) ALL EQUIPMENT SHALL BE INSTALLED IN ACCORDANCE WITH THE MANUFACTURER'S INSTALLATION INSTRUCTIONS.
- 2.) ALL OUTDOOR EQUIPMENT SHALL BE RAIN TIGHT WITH MINIMUM NEMA 3R RATING.
- 3.) ALL LOCATIONS ARE APPROXIMATE AND REQUIRE FIELD VERIFICATION.

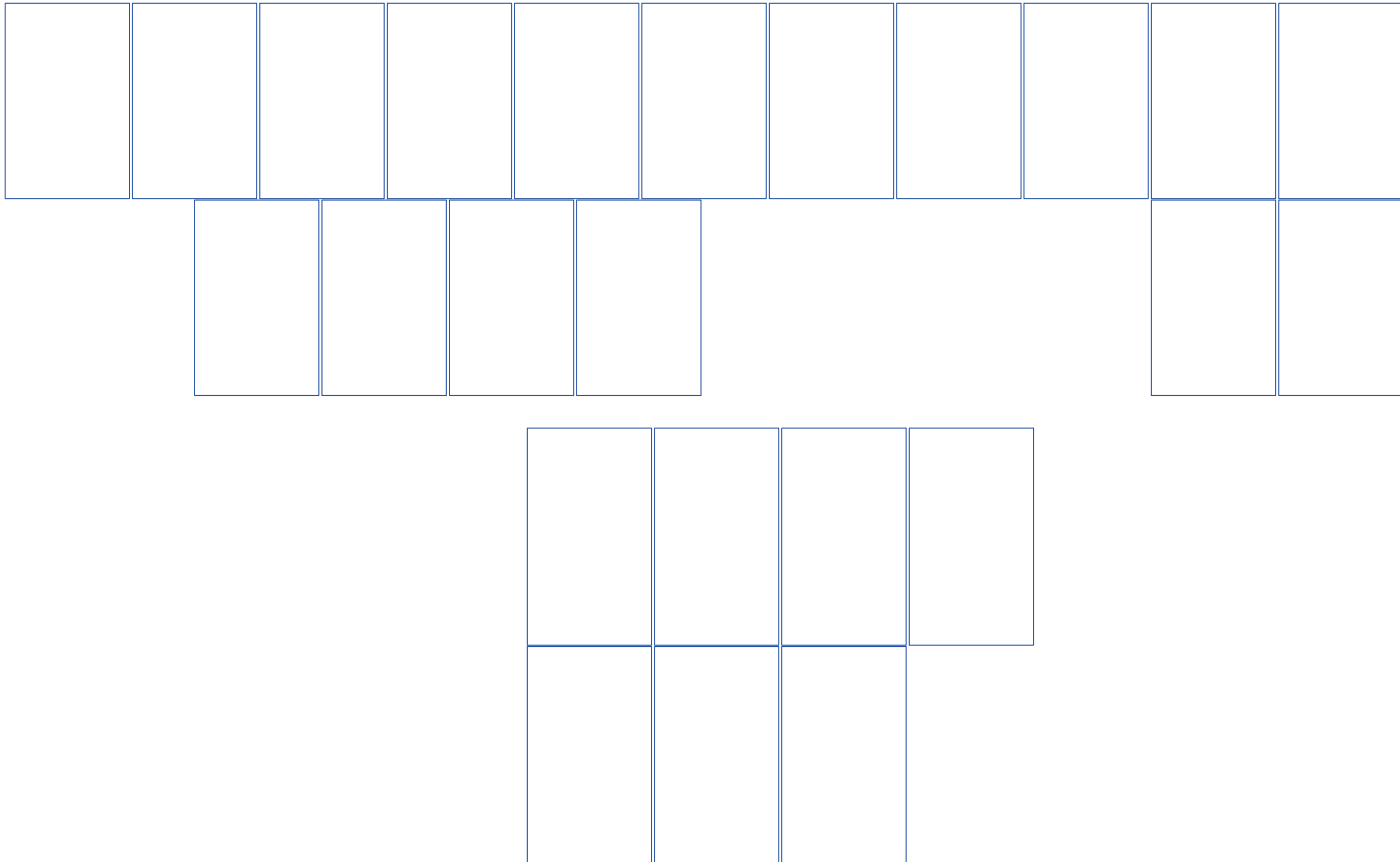

SUNPOWER SUPERVISOR S/N \_\_\_\_\_

CONTRACTOR



**FREEDOM<sup>™</sup>  
SOLAR POWER**

FREEDOM SOLAR LLC  
4801 FREIDRICH LN, STE 100  
AUSTIN, TX 78744  
512-759-8313  
TECL # 28621

REVISIONS

DESCRIPTION	DATE	REV
DESIGN PACKET	07/03/2024	-

PE STAMP

PROJECT NAME

**BILLY H RIGGSBEE**  
**10 BRADDOCK DRIVE**  
**LILLINGTON, NORTH**  
**CAROLINA, 27546**  
 (910) 658-7865  
 PROJECT ID: 114862

SHEET NAME

**STRING MAP &  
MONITORING  
LAYOUT**

SHEET SIZE

**ANSI B  
11" x 17"**

SHEET NUMBER

**PV-2**



SOLAR ARRAY - 10.200 KW DC STC, 9.216 KW AC, 1-PHASE  
 (24) SUNPOWER SPR-M425-H-AC (425W) PV MODULES  
 (24) TYPE H MODULE-INTEGRATED MICRO-INVERTERS: ENPHASE IQ7HS-66-M-US[240V] PV INVERTERS

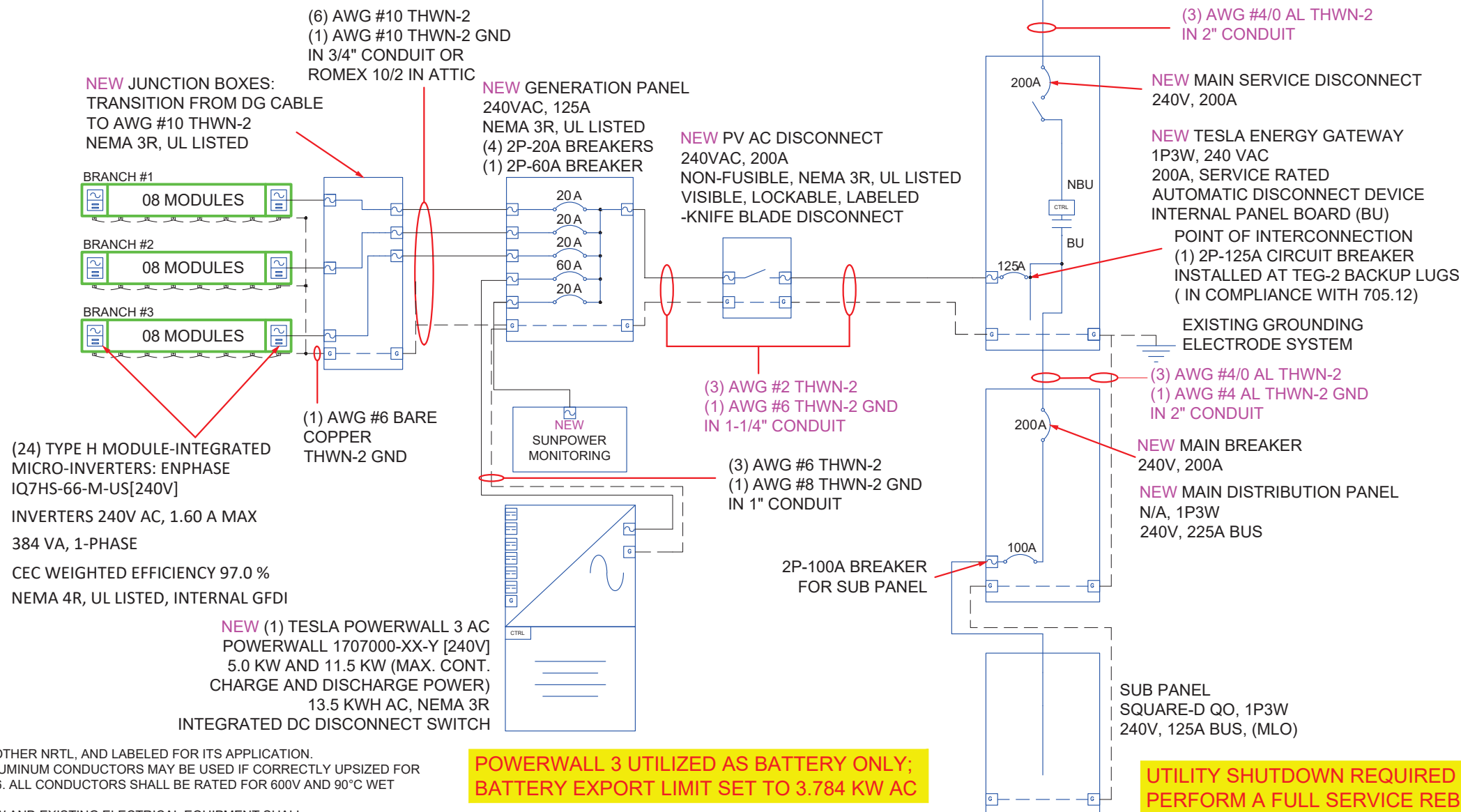

**ELECTRICAL NOTES**

- ALL EQUIPMENT TO BE LISTED BY UL OR OTHER NRTL, AND LABELED FOR ITS APPLICATION.
- ALL CONDUCTORS SHALL BE COPPER. ALUMINUM CONDUCTORS MAY BE USED IF CORRECTLY UPSIZED FOR AMPACITY RATING PER NEC 310.12 OR 310.16. ALL CONDUCTORS SHALL BE RATED FOR 600V AND 90°C WET ENVIRONMENT UNLESS OTHERWISE NOTED.
- WORKING CLEARANCES AROUND ALL NEW AND EXISTING ELECTRICAL EQUIPMENT SHALL COMPLY WITH NEC 110.26.
- DRAWINGS INDICATE THE GENERAL ARRANGEMENT OF SYSTEMS. CONTRACTOR SHALL FURNISH ALL NECESSARY OUTLETS, SUPPORTS, FITTINGS AND ACCESSORIES TO FULFILL APPLICABLE CODES AND STANDARDS.
- WHERE SIZES OF JUNCTION BOXES, RACEWAYS, AND CONDUITS ARE NOT SPECIFIED, THE CONTRACTOR SHALL SIZE THEM ACCORDINGLY. SPECIFIED CONDUIT AND WIRE SIZES ARE MINIMUM REQUIREMENTS AND LARGER SIZES SHALL BE PERMITTED.
- ALL WIRE TERMINATIONS SHALL BE APPROPRIATELY LABELED AND READILY VISIBLE.
- MAXIMUM MOUNTING HEIGHT FROM GRADE TO CENTER OF METER SOCKET SHALL BE 72" FOR RESIDENTIAL SINGLE PHASE METER SOCKETS 0-320 AMPS. MINIMUM MOUNTING HEIGHT IS 30" FROM FOR AUSTIN ENERGY, AND 48" FOR ALL OTHER JURISDICTIONS
- MINIMUM HORIZONTAL CLEARANCE FROM GAS REGULATOR TO ANY ELECTRICAL ENCLOSURE IS 36", EXCEPT AUSTIN ENERGY WHICH REQUIRES 48" CLEARANCE FROM GAS TO METER SOCKET
- PV DISCONNECT SHALL BE VISIBLE, LOCKABLE AND LABELED AND THE DOOR CANNOT BE OPENED WHEN HANDLE IS IN ON POSITION
- BY DEFAULT THE MONITORING DEVICE IS SHOWN CONNECTED TO A 20-AMP BREAKER IN THE SOLAR LOAD CENTER. ALTERNATIVELY, THE MONITORING DEVICE MAY BE CONNECTED TO A 20-AMP BREAKER AT THE MAIN DISTRIBUTION PANEL.
- ALL EQUIPMENT TERMINATIONS SHALL BE RATED FOR 75 DEGREES OR GREATER
- ALL CT WIRES SHALL BE CONSIDERED CLASS 1 PER NEC ARTICLE 725, AND BE MARKED AS RATED FOR 600V. PER 725.48(A) CLASS 1 CIRCUITS SHALL BE PERMITTED TO OCCUPY THE SAME RACEWAY AS OTHER CIRCUITS PROVIDED ALL CONDUCTORS ARE INSULATED FOR THE MAXIMUM VOLTAGE OF ANY CONDUCTOR IN THE RACEWAY.
- AWG #10 COPPER CONDUCTORS ARE SPECIFIED AS THE DEFAULT WIRE REQUIRED FROM THE PV ARRAY TO THE SOLAR LOAD CENTER, HOWEVER, AWG #12 COPPER CONDUCTORS MAY BE UTILIZED IF BOTH OF THE FOLLOWING CONDITIONS ARE MET: THE LENGTH OF THE CONDUCTOR IS LESS THAN 75 FT AND THERE ARE LESS THAN 8 CURRENT-CARRYING CONDUCTORS WITHIN THE RACEWAY.

**POWERWALL 3 UTILIZED AS BATTERY ONLY; BATTERY EXPORT LIMIT SET TO 3.784 KW AC**

**UTILITY SHUTDOWN REQUIRED TO PERFORM A FULL SERVICE REBUILD.**

CALCULATIONS FOR CURRENT CARRYING CONDUCTORS
<b>INVERTER OUTPUT WIRE AMPACITY CALCULATION</b> [NEC 690.8(A)(3)]: 1.60A PER INVERTER TYPE H MODULE-INTEGRATED MICRO-INVERTERS: ENPHASE IQ7HS-66-M-US[240V] MAXIMUM INVERTER BRANCH CURRENT = (10)(1.60A) = 16.00A CONTINUOUS USE: #10 WIRE 75°C DERATED AMPACITY = (0.80)(35.0A) = 28.00A 28.00A > 16.00A CONDITIONS OF USE: #10 WIRE 90°C DERATED AMPACITY = (0.91)(0.80)(40.0A) = 29.12A 29.12A > 16.00A
<b>GENERATION PANEL OUTPUT WIRE AMPACITY CALCULATION</b> [NEC 690.8(A)(3)]: 1.60A PER INVERTER TYPE H MODULE-INTEGRATED MICRO-INVERTERS: ENPHASE IQ7HS-66-M-US[240V] [NEC 690.8(A)(3)]: 48.0A PER TESLA POWERWALL 3 BATTERY INVERTER COMBINED CURRENT = (24)(1.60A)+(1x 48A) = 86.40A CONTINUOUS USE: #2 WIRE 75°C DERATED AMPACITY = (0.80)(115A) = 92.00A 92.00A > 86.40A CONDITIONS OF USE: #2 WIRE 90°C DERATED AMPACITY = (0.91)(130A) = 118.30A 118.30A > 86.40A

CALCULATIONS FOR OVERCURRENT DEVICES
<b>INVERTER BRANCH AC CURRENT CALCULATION</b> [NEC 690.8(A)(3)]: 1.60A PER INVERTER TYPE H MODULE-INTEGRATED MICRO-INVERTERS: ENPHASE IQ7HS-66-M-US[240V] MAXIMUM BRANCH INVERTER CURRENT = (10)(1.60A) = 16.00A MINIMUM OCPD = (16.00A)(1.25) = 20.00A USE 2P-20A BREAKERS IN GENERATION PANEL FOR INVERTER BRANCH OCPD
<b>SYSTEM AC CURRENT CALCULATION</b> [NEC 690.8(A)(3)]: 1.60A PER INVERTER TYPE H MODULE-INTEGRATED MICRO-INVERTERS: ENPHASE IQ7HS-66-M-US[240V] [NEC 690.8(A)(3)]: 48.0A PER TESLA POWERWALL 3 BATTERY INVERTER COMBINED CURRENT = (24)(1.60A)+(1 x 48A) = 86.40A MINIMUM OCPD = (86.40A)(1.25) = 108.00A USE (1) 2P-125A BREAKER IN TEG-2 FOR SYSTEM OCPD
<b>CALCULATION FOR OVERCURRENT POWERWALL DEVICES</b> 48.0A PER TESLA POWERWALL 3.0 BATTERY INVERTER <b>OUTPUT CURRENT CALCULATION</b> OUTPUT CURRENT = 48.00A MINIMUM OCPD = (48.00A)(1.25) = 60.00A USE (1) 2P-60A BREAKER IN GENERATION PANEL FOR POWERWALL OCPD

CONTRACTOR

**FREEDOM SOLAR POWER**  
 FREEDOM SOLAR LLC  
 4801 FREIDRICH LN, STE 100  
 AUSTIN, TX 78744  
 512-759-8313  
 TECL # 28621

REVISIONS		
DESCRIPTION	DATE	REV
DESIGN PACKET	07/03/2024	-

PE STAMP

PROJECT NAME

**BILLY H RIGGSBEE**  
**10 BRADDOCK DRIVE**  
**LILLINGTON, NORTH CAROLINA, 27546**  
 (910) 658-7865  
 PROJECT ID: 114862

SHEET NAME

**ELECTRICAL DIAGRAM**

SHEET SIZE

**ANSI B 11" x 17"**

SHEET NUMBER

**PV-3**

CONTRACTOR



**FREEDOM<sup>™</sup>  
SOLAR POWER**

FREEDOM SOLAR LLC  
4801 FREIDRICH LN, STE 100  
AUSTIN, TX 78744  
512-759-8313  
TECL # 28621

REVISIONS

DESCRIPTION	DATE	REV
DESIGN PACKET	07/03/2024	-

PE STAMP

PROJECT NAME

**BILLY H RIGGSBEE**  
**10 BRADDOCK DRIVE**  
**LILLINGTON, NORTH**  
**CAROLINA, 27546**

(910) 658-7865  
 PROJECT ID: 114862

SHEET NAME

**EQ.WALL**

SHEET SIZE

**ANSI B**  
**11" x 17"**

SHEET NUMBER

**PV-4**

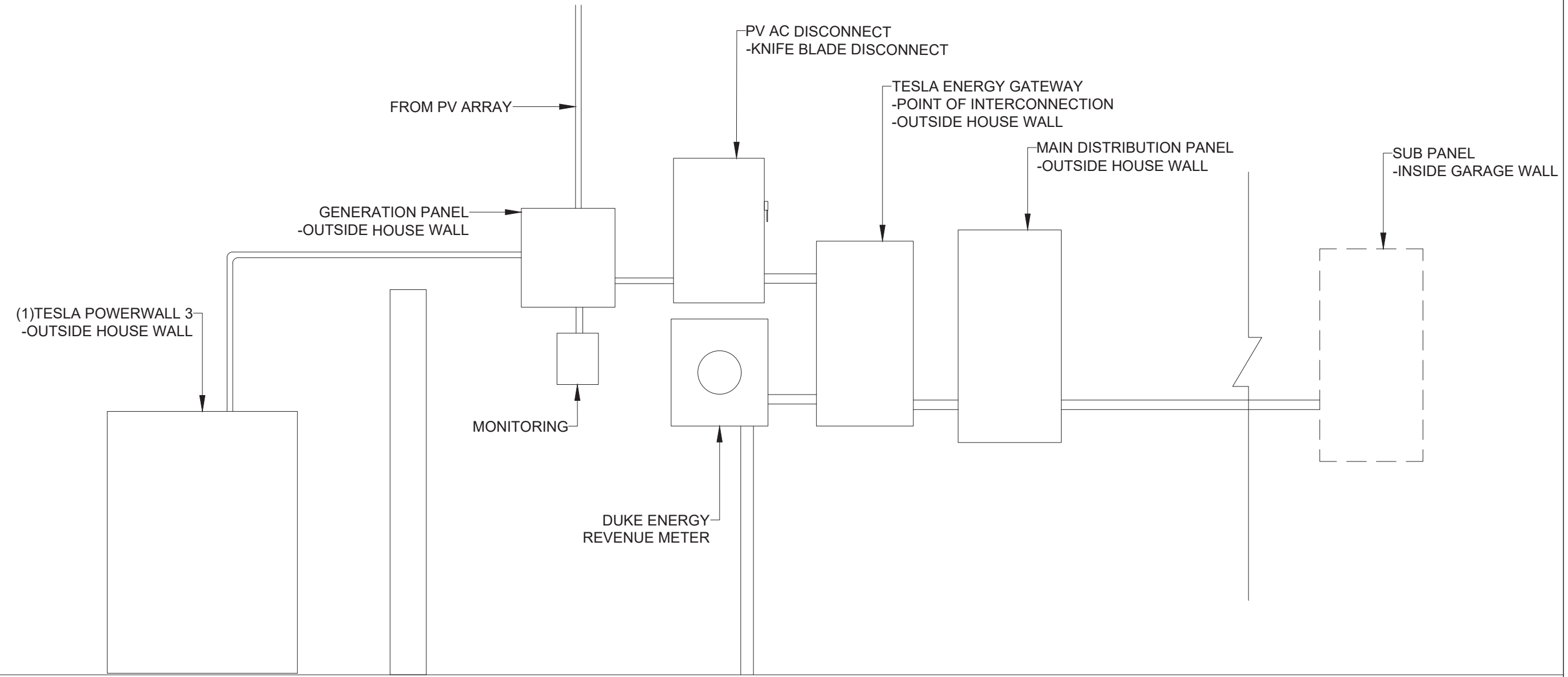



CONTRACTOR



**FREEDOM™  
SOLAR POWER**

FREEDOM SOLAR LLC  
4801 FREIDRICH LN, STE 100  
AUSTIN, TX 78744  
512-759-8313  
TECL # 28621

REVISIONS

DESCRIPTION	DATE	REV
DESIGN PACKET	07/03/2024	-

PE STAMP

PROJECT NAME

**BILLY H RIGGSBEE**  
10 BRADDOCK DRIVE  
LILLINGTON, NORTH  
CAROLINA, 27546  
(910) 658-7865  
PROJECT ID: 114862

SHEET NAME

**MOUNTING DETAIL**

SHEET SIZE

**ANSI B  
11" x 17"**

SHEET NUMBER

**PV-5**

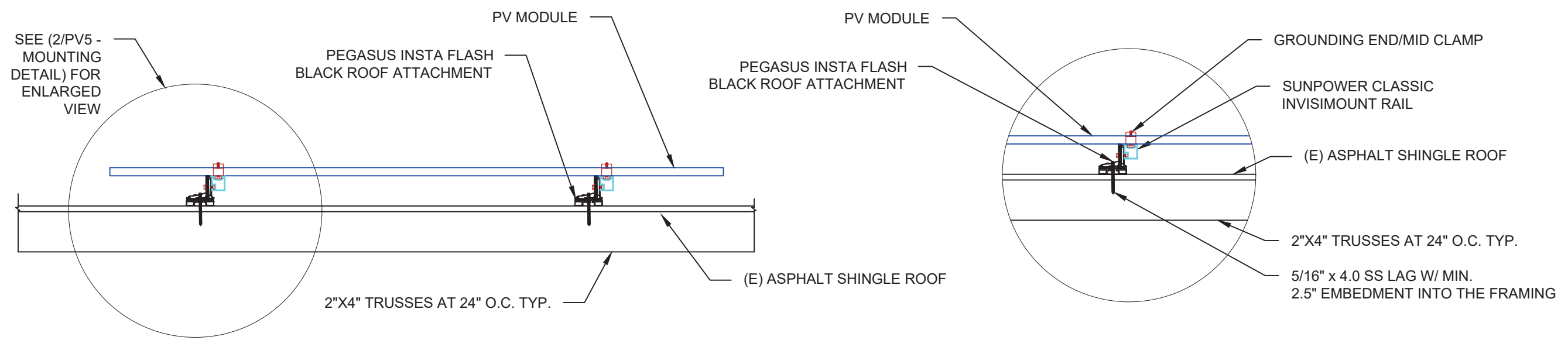

MOUNTING METHOD  
NTS 1

MOUNTING DETAIL  
NTS 2

NOTE: NOT ALL LABELS MAY BE APPLICABLE

**SIGNAGE REQUIREMENTS**

- > RED BACKGROUND
- > WHITE LETTERING
- > MIN. 3/8" LETTER HEIGHT
- > ALL CAPITAL LETTERS
- > ARIAL OR SIMILAR FONT
- > REFLECTIVE, WEATHER RESISTANT MATERIAL, UL 969

**PV SYSTEM DISCONNECT**

REQ'D BY: NEC 690.13(B)

A

APPLY TO:  
PV DISCONNECT

**WARNING**  
ELECTRIC SHOCK HAZARD.  
DO NOT TOUCH TERMINALS.  
TERMINALS ON THE LINE AND  
LOAD SIDES MAY BE  
ENERGIZED IN THE OPEN  
POSITION.

REQ'D BY: NEC 690.13(B)

B

APPLY TO:  
PV DISCONNECT

**WARNING: PHOTOVOLTAIC  
POWER SOURCE**

REQ'D BY: NEC 690.31(G)(3)

C

APPLY TO:  
RACEWAYS, CABLE TRAYS,  
OTHER WIRING METHODS, AND  
ENCLOSURES THAN CONTAIN  
PV SYSTEM DC CONDUCTORS

**WARNING**  
POWER SOURCE OUTPUT  
CONNECTION. DO NOT  
RELOCATE THIS  
OVERCURRENT DEVICE

REQ'D BY: NEC 705.12(B)(2)(3)(b)

D

APPLY TO:  
DISTRIBUTION EQUIPMENT  
ADJACENT TO BACK-FED BREAKER

**2" ADDRESS NUMBERS**

REQ' BY: AHJ

E

APPLY TO:  
REVENUE METER SOCKET  
(IF APPLICABLE)

**REVENUE METER**

REQ'D BY: AHJ

F

APPLY TO:  
REVENUE METER SOCKET  
(IF APPLICABLE)

**MONITORING**

REQ'D BY: FREEDOM SOLAR

G

APPLY TO:  
MONITORING DEVICE ENCLOSURE

**RAPID SHUTDOWN SWITCH  
FOR SOLAR PV SYSTEM**

REQ'D BY: NEC 690.56(C)(2)

H

APPLY TO:  
PV DISCONNECT

**PCS CONTROLLED CURRENT SETTING: 7.320A**  
**DATE OF CALCULATION & SETTING:**

**THE MAXIMUM OUTPUT CURRENT FOR THIS  
SYSTEM IS CONTROLLED ELECTRONICALLY.  
THE SETTING FOR THE EMS CURRENT  
LIMITING FEATURE SHALL NOT BE BYPASSED.  
REFER TO THE MANUFACTURER'S  
INSTRUCTIONS FOR MORE INFORMATION.**

REQ'D BY: 750.30

I

APPLY TO:  
ALL VIRTUAL PANELS  
(ENCLOSURE'S EXTERIOR)

**PHOTOVOLTAIC SYSTEM  
AC DISCONNECT**  
OPERATING CURRENT: 86.40A  
OPERATING VOLTAGE: 240 VAC

REQ'D BY: 690.56(1)(a)

J

APPLY TO:  
PV DISCONNECT

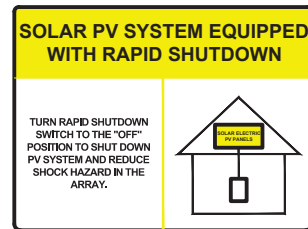

REQ'D BY: NEC 690.56(C)(1)(a)

K

APPLY TO:  
MAIN DISTRIBUTION PANEL

**CAUTION**  
POWER TO THIS BUILDING IS ALSO SUPPLIED FROM THE  
FOLLOWING SOURCES WITH DISCONNECTS AS SHOWN:

UTILITY SUPPLY & CUSTOMER  
SERVICE PANEL

PV AC DISCONNECT

RAPID SHUTDOWN SWITCH

FRONT

REQ'D BY: 705.10

L

APPLY TO:  
MAIN DISTRIBUTION PANEL  
(\*ONLY REQUIRED IF PV SYSTEM  
DISCONNECT IS NOT GROUPED  
WITH MAIN SERVICE DISCONNECT)  
**SEE SHEET PV-6 FOR SITE  
SPECIFIC LABELS**

**THIS SENSOR IS PART OF A POWER CONTROL  
SYSTEM. DO NOT REMOVE OR DISABLE.  
REPLACE WITH SAME TYPE AND RATING.**

APPLY TO:  
CTS

M

CONTRACTOR

**FREEDOM  
SOLAR POWER**

FREEDOM SOLAR LLC  
4801 FREDRICH LN, STE 100  
AUSTIN, TX 78744  
512-759-8313  
TECL # 28621

REVISIONS

DESCRIPTION	DATE	REV
DESIGN PACKET	07/03/2024	-

PE STAMP

PROJECT NAME

**BILLY H RIGGSBEE**  
**10 BRADDOCK DRIVE**  
**LILLINGTON, NORTH**  
**CAROLINA, 27546**

(910) 658-7865  
PROJECT ID: 114862

SHEET NAME

**SYSTEM  
LABELING  
DETAIL**

SHEET SIZE

**ANSI B  
11" x 17"**

SHEET NUMBER

**PV-6**



# CAUTION: MULTIPLE SOURCES OF POWER LOCATION OF EACH POWER SOURCE DISCONNECTING MEANS SHOWN BELOW

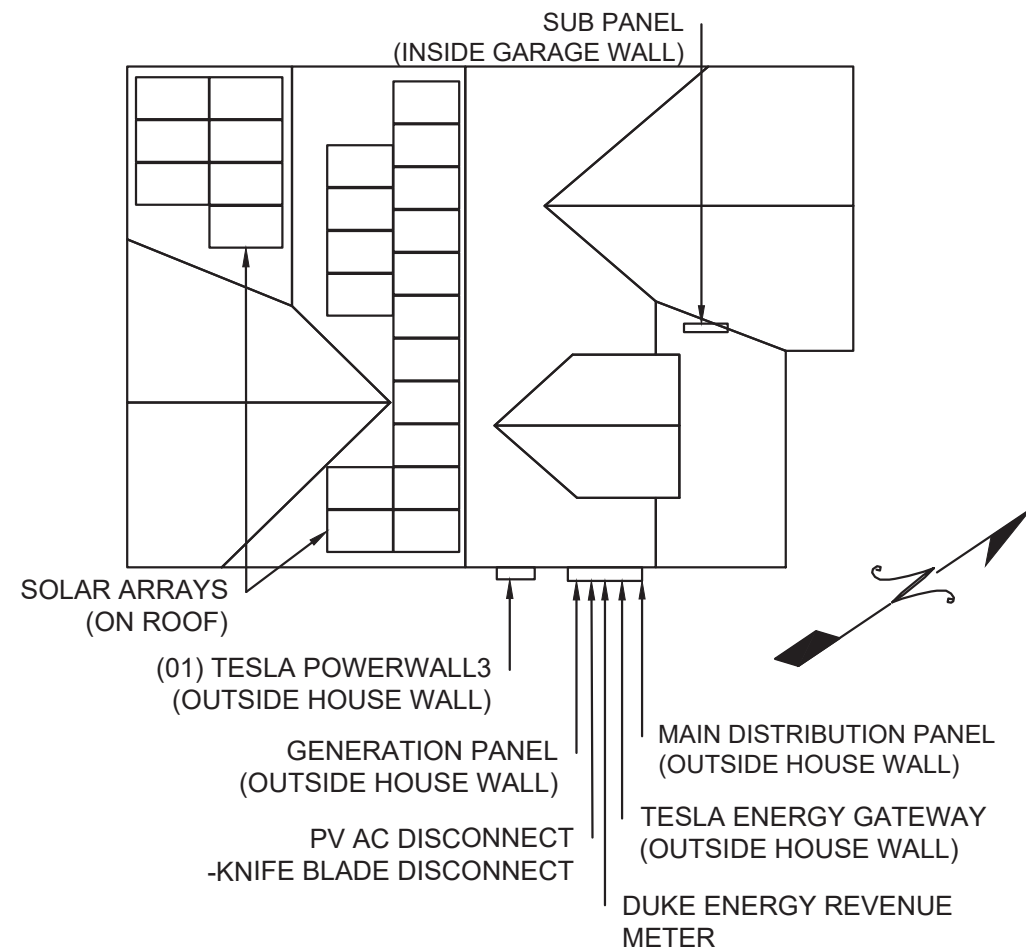

QUESTIONS, CALL:  
800-504-2337  
[www.freedomsolarpower.com](http://www.freedomsolarpower.com)



CONTRACTOR

**FREEDOM<sup>™</sup>  
SOLAR POWER**

FREEDOM SOLAR LLC  
4801 FREDRICH LN, STE 100  
AUSTIN, TX 78744  
512-759-8313  
TECL # 28621

REVISIONS		
DESCRIPTION	DATE	REV
DESIGN PACKET	07/03/2024	-

PE STAMP

PROJECT NAME

**BILLY H RIGGSBEE  
10 BRADDOCK DRIVE  
LILLINGTON, NORTH  
CAROLINA, 27546**

(910) 658-7865  
PROJECT ID: 114862

SHEET NAME

**SITE  
DIRECTORY  
PLACARD**

SHEET SIZE

**ANSI B  
11" x 17"**

SHEET NUMBER

**PV-7**

USE THE SAFETY SYMBOL KEY TO DRAW IN THE CONTROLLED ACCESS ZONE (CAZ), LADDER PLACEMENT, METER LOCATION, FALL PROTECTION ANCHOR POINT, AND ANY OTHER HAZARD.

HARD HAT IS REQUIRED AT ALL TIMES IN CAZ

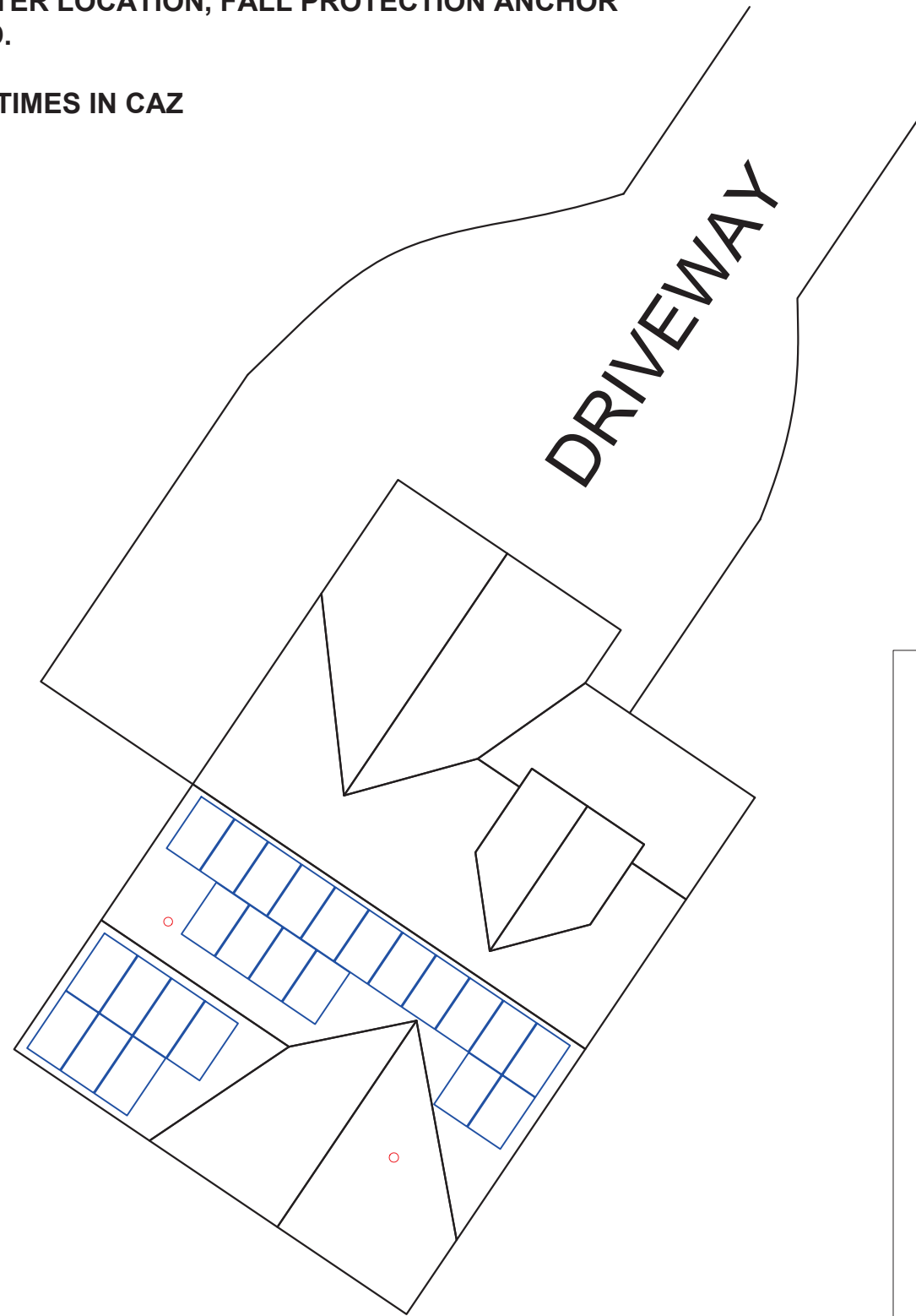

**SAFETY SYMBOL KEY**

- CAZ
- L** LADDER
- M** METER
- ==== POWER LINES
- R** RESTRAINT ANCHOR
- A** ARREST ANCHOR

**CONDUCT SAFETY MEETING WITH ALL CREW MEMBERS ON SITE AT THE BEGINNING OF EACH JOB. USE SIGN IN SHEET BELOW.**

1. \_\_\_\_\_
2. \_\_\_\_\_
3. \_\_\_\_\_
4. \_\_\_\_\_
5. \_\_\_\_\_

COMPETENT PERSON: \_\_\_\_\_ JOB START DATE: \_\_\_\_\_

CONTRACTOR

**FREEDOM SOLAR POWER**  
 FREEDOM SOLAR LLC  
 4801 FREDRICH LN, STE 100  
 AUSTIN, TX 78744  
 512-759-8313  
 TECL # 28621

REVISIONS		
DESCRIPTION	DATE	REV
DESIGN PACKET	07/03/2024	-

PE STAMP

PROJECT NAME

**BILLY H RIGGSBEE**  
**10 BRADDOCK DRIVE**  
**LILLINGTON, NORTH**  
**CAROLINA, 27546**  
 (910) 658-7865  
 PROJECT ID: 114862

SHEET NAME

**SAFETY PLAN**

SHEET SIZE

**ANSI B**  
**11" x 17"**

SHEET NUMBER

**PV-8**



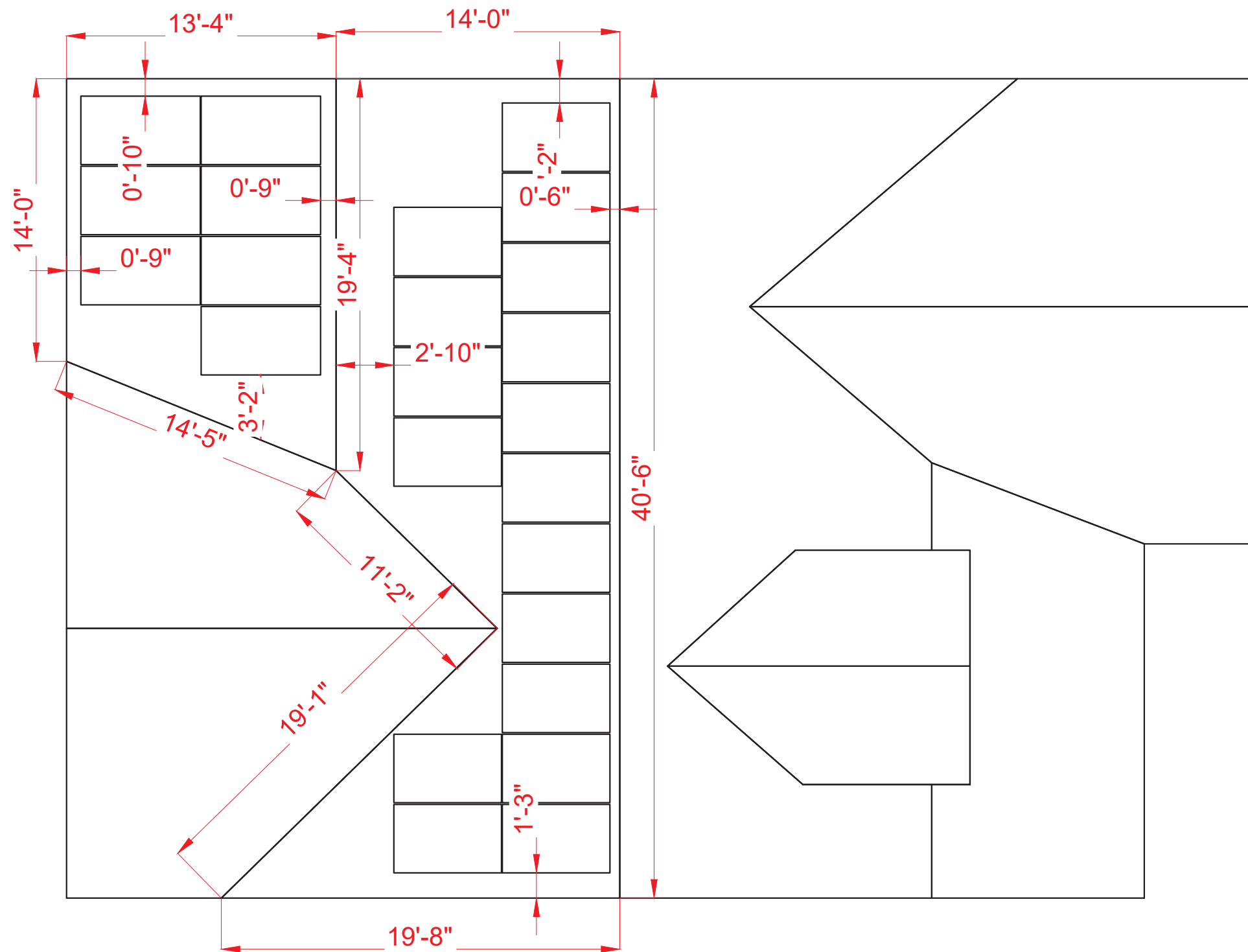

**HOUSE HEIGHT TOTAL: 18'-8"**  
**AVG HOUSE HEIGHT: 14'-4'**



### 420-440W Residential AC Module

#### SunPower® Maxeon® Technology

Built specifically for use with the SunPower Equinox® system, the only fully integrated solar solution designed, engineered, and warranted by one company.



#### Highest Power AC Density Available.

The patented, solid-copper foundation Maxeon Gen 6 cell is over 5% larger than prior generations, delivering the highest efficiency AC solar panel available.<sup>1</sup>

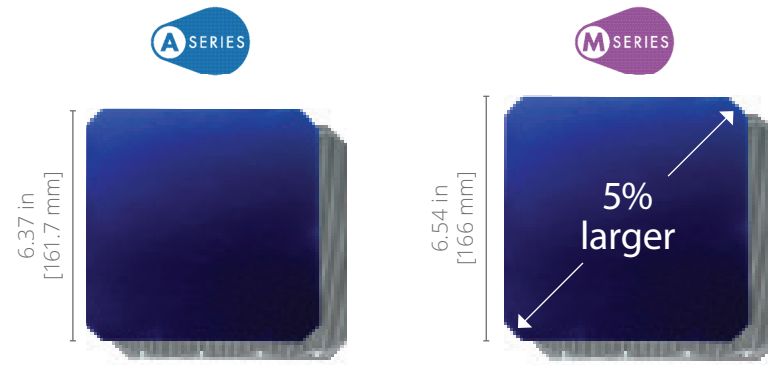

#### Part of the SunPower Equinox® Solar System

- Compatible with mySunPower™ monitoring
- Seamless aesthetics

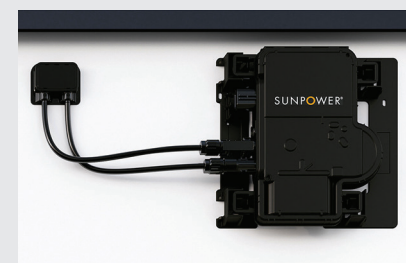

#### Factory-integrated Microinverter

- Highest-power integrated AC module in solar
- Engineered and calibrated by SunPower for SunPower AC modules



#### Highest Lifetime Energy and Savings

Designed to deliver 60% more energy over 25 years in real-world conditions like partial shade and high temperatures.<sup>2</sup>

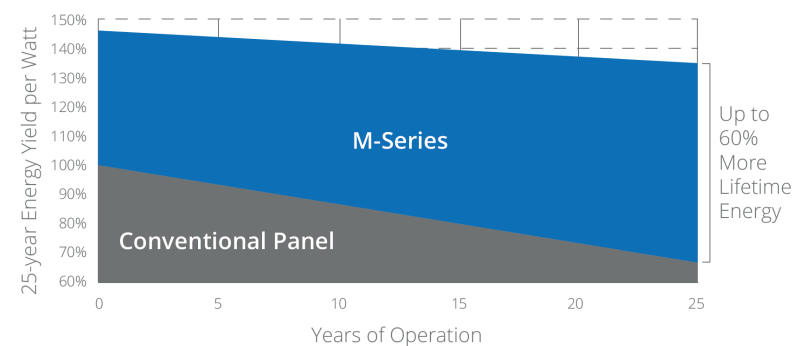

#### Best Reliability, Best Warranty

With more than 42.6 million and 15 GW modules deployed around the world, SunPower technology is proven to last. That's why we stand behind our module and microinverter with the industry's best 25-year Combined Power and Product Warranty.

AC Electrical Data		
	@240 VAC	@208 VAC
Inverter Model: Type H (Enphase IQ7HS)		
Peak Output Power (VA)	384	369
Max. Continuous Output Power (VA)	384	369
Nom. (L-L) Voltage/Range <sup>3</sup> (V)	240 / 211–264	208 / 183–229
Max. Continuous Output Current (Arms)	1.60	1.77
Max. Units per 20 A (L-L) Branch Circuit <sup>4</sup>	10	9
CEC Weighted Efficiency	97.0%	96.5%
Nom. Frequency	60 Hz	
Extended Frequency Range	47–68 Hz	
AC Short Circuit Fault Current Over 3 Cycles	4.82 A rms	
Overvoltage Class AC Port	III	
AC Port Backfeed Current	18 mA	
Power Factor Setting	1.0	
Power Factor (adjustable)	0.85 (inductive) / 0.85 (capacitive)	

DC Power Data					
	SPR-M440-H-AC	SPR-M435-H-AC	SPR-M430-H-AC	SPR-M425-H-AC	SPR-M420-H-AC
Nom. Power <sup>6</sup> (Pnom) W	440	435	430	425	420
Power Tolerance	+5/-0%				
Module Efficiency	22.8%	22.5%	22.3%	22.0%	21.7%
Temp. Coef. (Power)	-0.29% / °C				
Shade Tolerance	Integrated module-level max. power point tracking				

Tested Operating Conditions	
Operating Temp.	-40° F to +185°F (-40°C to +85°C)
Max. Ambient Temp.	122°F (50°C)
Max. Test Load <sup>8</sup>	Wind: 125 psf, 6000 Pa, 611 kg/m <sup>2</sup> back Snow: 187 psf, 9000 Pa, 917 kg/m <sup>2</sup> front
Max. Design Load	Wind: 75 psf, 3600 Pa, 367 kg/m <sup>2</sup> back Snow: 125 psf, 6000 Pa, 611 kg/m <sup>2</sup> front
Impact Resistance	1 inch (25 mm) diameter hail at 52 mph (23 m/s)

Mechanical Data	
Solar Cells	66 Maxeon Gen 6
Front Glass	High-transmission tempered glass with anti-reflective coating
Environmental Rating	Outdoor rated
Frame	Class 1 black anodized (highest AAMA rating)
Weight	48 lb (21.8 kg)
Recommended Max. Module Spacing	1.3 in. (33 mm)

1 Based on datasheet review of websites of top 20 manufacturers per Wood Mackenzie US PV Leaderboard Q3 2021.  
 2 Maxeon 435 W, 22.5% efficient, compared to a Conventional Panel on same-sized arrays (260 W, 16% efficient, approx. 1.6 m<sup>2</sup>), 7.9% more energy per watt (based on PVsyst pan files for avg. US climate), 0.5%/yr slower degradation rate (Jordan, et. al. "Robust PV Degradation Methodology and Application." PVSC 2018).  
 3 Voltage range can be extended beyond nominal if required by the utility.  
 4 Limits may vary. Refer to local requirements to define the number of microinverters per branch in your area.  
 5 Factory set to IEEE 1547a-2014 default settings. CA Rule 21 default settings profile set during commissioning.  
 6 Standard Test Conditions (1000 W/m<sup>2</sup> irradiance, AM 1.5, 25°C). All DC voltage is fully contained within the module.  
 7 UL Listed as PVRSE and conforms with NEC 2017 and NEC 2020 690.12 and C22.1-2015 Rule 64-218 Rapid Shutdown of PV Systems, for AC and DC conductors; when installed according to manufacturer's instructions.  
 8 Please read the safety and installation instructions for more information regarding load ratings and mounting configurations.

See [www.sunpower.com/company](http://www.sunpower.com/company) for more reference information. Specifications included in this datasheet are subject to change without notice.

©2022 SunPower Corporation. All rights reserved. SUNPOWER, the SUNPOWER logo, EQUINOX and MYSUNPOWER are trademarks or registered trademarks of SunPower Corporation in the U.S. MAXEON is a registered trademark of Maxeon Solar Technologies, Ltd. For more information visit [www.maxeon.com/legal](http://www.maxeon.com/legal).

Warranties, Certifications, and Compliance	
Warranties	<ul style="list-style-type: none"> <li>• 25-year limited power warranty</li> <li>• 25-year limited product warranty</li> </ul>
Certifications and Compliance	<ul style="list-style-type: none"> <li>• UL 1741 / IEEE-1547</li> <li>• UL 1741 AC Module (Type 2 fire rated)</li> <li>• UL 61730</li> <li>• UL 62109-1 / IEC 62109-2</li> <li>• FCC Part 15 Class B</li> <li>• ICES-0003 Class B</li> <li>• CAN/CSA-C22.2 NO. 107.1-01</li> <li>• CA Rule 21 (UL 1741 SA)<sup>5</sup> (includes Volt/Var and Reactive Power Priority)</li> <li>• UL Listed PV Rapid Shutdown Equipment<sup>7</sup></li> </ul> <p>Enables installation in accordance with:</p> <ul style="list-style-type: none"> <li>• NEC 690.6 (AC module)</li> <li>• NEC 690.12 Rapid Shutdown (inside and outside the array)</li> <li>• NEC 690.15 AC Connectors, 690.33(A)-(E)(1)</li> </ul> <p>When used with AC module Q Cables and accessories (UL 6703 and UL 2238)<sup>2</sup>:</p> <ul style="list-style-type: none"> <li>• Rated for load break disconnect</li> </ul> <p>When used with InvisiMount racking and InvisiMount accessories (UL 2703):</p> <ul style="list-style-type: none"> <li>• Module grounding and bonding through InvisiMount</li> <li>• Class A fire rated</li> </ul>
PID Test	1000 V: IEC 62804

Packaging Configuration	
Modules per pallet	25
Packaging box dimensions	75.4 x 42. (1915 x 1072 x 1220 mm)
Pallet gross weight	1300.7 lb (590 kg)
Pallets per container	32
Net weight per container	41,623 lb (18,880 kg)

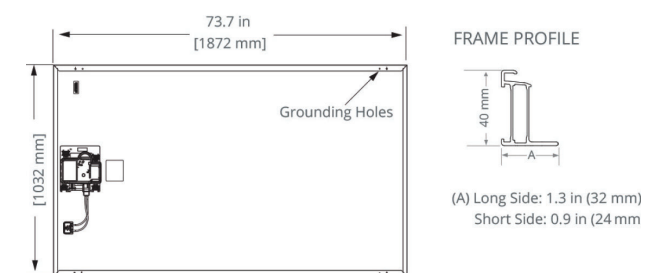

Please read the safety and installation instructions for details.



539973 RevD  
April 2022



# Enphase IQ7HS Microinverter

The high-powered smart grid-ready **Enphase IQ7HS Microinverter™** with integrated MC4 connectors dramatically simplify the installation process while achieving the highest system efficiency.

The IQ Series Microinverters extend the reliability standards set forth by previous generations and undergo over a million hours of power-on testing, enabling Enphase to provide an industry-leading warranty of up to 25 years.



### Easy to Install

- Lightweight and simple
- Faster installation with improved, lighter two-wire cabling
- Built-in rapid shutdown compliant (NEC 2014, 2017 & 2020)

### Efficient and Reliable

- Optimized for high powered 66-cell\* modules
- Highest CEC efficiency of 97.0%
- More than a million hours of testing
- Class II double-insulated enclosure
- UL listed

### Smart Grid Ready

- Complies with advanced grid support, voltage and frequency ride-through requirements
- Remotely updates to respond to changing grid requirements
- Configurable for varying grid profiles
- Meets CA Rule 21 (UL 1741-SA)

\* The IQ7HS is required to support 66-cell modules.

## Enphase IQ7HS Microinverter

INPUT DATA (DC)	IQ7HS-66-M-US	
Commonly used module pairings <sup>1</sup>	320 W - 460 W +	
Module compatibility	66-cell PV modules	
Maximum input DC voltage	59 V	
Peak power tracking voltage	38 V - 43 V	
Operating range	20 V - 59 V	
Min/Max start voltage	30 V / 59 V	
Max DC short circuit current (module Isc)	15 A	
Overvoltage class DC port	II	
DC port backfeed current	0 A	
PV array configuration	1 x 1 ungrounded array; No additional DC side protection required; AC side protection requires max 20A per branch circuit	

OUTPUT DATA (AC)	@240 VAC	@208 VAC
Peak output power	384 VA	369 VA
Maximum continuous output power	384 VA	369 VA
Nominal (L-L) voltage/range <sup>2</sup>	240 V / 211-264 V	208 V / 183-229 V
Maximum continuous output current	1.60 A (240V)	1.77 A (208V)
Nominal frequency	60 Hz	60 Hz
Extended frequency range	47 to 68 Hz	47 to 68 Hz
AC short circuit fault current over 3 cycles	4.82 A	4.82 A
Maximum units per 20 A (L-L) branch circuit <sup>3</sup>	10	9
Overvoltage class AC port	III	III
AC port backfeed current	18 mA	18 mA
Power factor setting	1.0	1.0
Power factor (adjustable)	0.85 leading ...0.85 lagging	0.85 leading ...0.85 lagging

EFFICIENCY	@240 V	@208 V
CEC weighted efficiency	97.0 %	96.5 %

MECHANICAL DATA	
Ambient temperature range	-40°C to +60°C
Relative humidity range	4% to 100% (condensing)
Connector type	Staubli made MC4
Dimensions (WxHxD)	212 mm x 175 mm x 30.2 mm (without bracket)
Weight	1.08 kg (2.38 lbs)
Cooling	Natural convection - No fans
Approved for wet locations	Yes
Pollution degree	PD3
Enclosure	Class II, corrosion resistant polymeric enclosure
Environmental category / UV exposure rating	NEMA type 6 / outdoor
Altitude	2000m

FEATURES	
Communication	Power Line Communication (PLC)
Disconnecting means	The AC and DC connectors have been evaluated and approved by UL for use as the load-break disconnect means required by NEC 690 and C22.1-2018 Rule 64-220.
Compliance	CA Rule 21 (UL 1741-SA), HECO v1.1 UL 62109-1, UL1741/IEEE1547, FCC Part 15 Class B, ICES-0003 Class B, CAN/CSA-C22.2 NO. 107.1-01 This product is UL Listed as PV Rapid Shut Down Equipment and conforms with NEC-2014, NEC-2017 section 690.12, NEC 2020 and C22.1-2015 Rule 64-218 Rapid Shutdown of PV Systems, for AC and DC conductors, when installed according to manufacturer's instructions.

1. No enforced DC/AC ratio. See the compatibility calculator at <https://enphase.com/en-us/support/module-compatibility>.  
 2. Nominal voltage range can be extended beyond nominal if required by the utility.  
 3. Limits may vary. Refer to local requirements to define the number of microinverters per branch in your area.

To learn more about Enphase offerings, visit [enphase.com](https://enphase.com)





# SunPower® EnergyLink™ | Residential and Commercial PVS6

## Improve Support, Reduce Maintenance Costs

An intuitive monitoring website enables you to:

- See a visual map of customer sites
- Remotely manage hundreds of sites
- Receive elective system reports
- Locate system issues and remotely diagnose
- Diagnose issues online
- Drill down for the status of individual devices

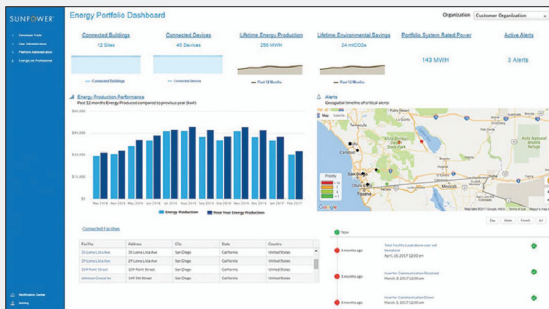

## Add Value for Customers

With the SunPower Monitoring System customers can:

- See what their solar system produces each day, month, or year
- Optimize their solar investment and save on energy expenses
- See their energy use and estimated bill savings
- See their solar system's performance using the SunPower monitoring website or mobile app



## SunPower EnergyLink—Plug-and-Play Installation

This complete solution for residential and commercial monitoring and control includes the SunPower® PV Supervisor 6 (PVS6) which improves the installation process, overall system reliability, and customer experience.

- Compact footprint for improved aesthetics
- Robust cloud connectivity and comprehensive local connectivity
- Flexible configuration of devices during installation
- Consumption metering
- Revenue-grade production metering (pending)
- Web-based commissioning
- Remote diagnostics of PVS6 and inverters
- Durable UL Type 3R enclosure reduces maintenance costs
- Easy integration with SunPower eBOS



## Robust Cloud Connectivity

Multiple options to maintain optimal connectivity:

- Hardwired Ethernet
- Wi-Fi
- Cellular backup

# SunPower® EnergyLink™ | Residential and Commercial PVS6

## SunPower Monitoring Websites

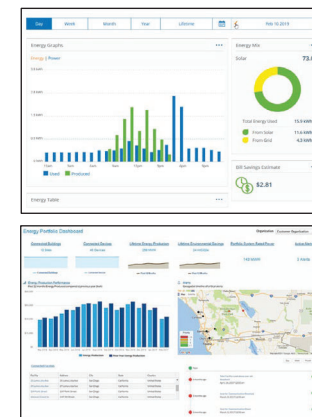

## PVS6



## SunPower AC Modules

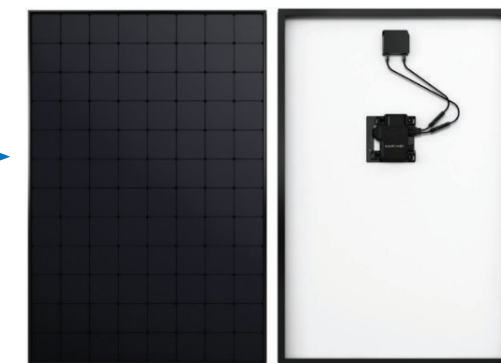

Multiple communication options include Ethernet, Wi-Fi, and cellular.

Site Requirements	
Number of SunPower AC modules supported per PVS6	85
Internet access	High-speed internet access via accessible router or switch
Power	<ul style="list-style-type: none"> <li>• 100–240 VAC (L–N), 50 or 60 Hz</li> <li>• 208 VAC (L–L in 3-phase), 60 Hz</li> </ul>

Operating Conditions	
Temperature	–22°F to +140°F (–30°C to +60°C)
Humidity (maximum)	95%, non-condensing

Mechanical	
Weight	5.5 lbs (2.5 kg)
Dimensions	11.8 × 8.0 × 4.2 in. (30.5 × 20.5 × 10.8 cm)
Enclosure rating	UL50E Type 3R

Communication	
RS-485	Inverters and meters
Integrated Metering	<ul style="list-style-type: none"> <li>• One channel of revenue-grade production metering</li> <li>• Two channels of consumption metering</li> </ul>
Ethernet	1 LAN (or optional WAN) port
PLC	PLC for SunPower AC modules
Wi-Fi	802.11b/g/n 2.4 GHz and 5 GHz
Cellular	LTE Cat-M1/3G UMTS
ZigBee	IEEE 802.15.4 MAC, 2.4GHz ISM band
Data Storage	60 days
Upgrades	Automatic firmware upgrades

Web and Mobile Device Support	
Customer site	<a href="http://monitor.us.sunpower.com">monitor.us.sunpower.com</a>
Partner site	<a href="http://pvs6gmt.us.sunpower.com">pvs6gmt.us.sunpower.com</a>
Browsers	Firefox, Safari, and Chrome
Mobile devices	iPhone®, iPad®, and Android™
Customer app	<ol style="list-style-type: none"> <li>1. Create account online at: <a href="http://monitor.us.sunpower.com">monitor.us.sunpower.com</a>.</li> <li>2. On a mobile device, download the SunPower Monitoring app from Apple App Store™ or Google Play™ store.</li> <li>3. Sign in using account email and password.</li> </ol>

Warranty and Certifications	
Warranty	10-year Limited Warranty
Certifications	UL, cUL, CE, UL 61010-1 and -2, FCC Part 15 (Class B)





# SunPower® InvisiMount™ | Residential Mounting System

## Simple and Fast Installation

- Integrated module-to-rail grounding
- Pre-assembled mid and end clamps
- Levitating mid clamp for easy placement
- Mid clamp width facilitates consistent, even module spacing
- UL 2703 Listed integrated grounding

## Flexible Design

- Addresses sloped and low-sloped residential roofs
- Design in landscape and portrait with up to 8' rail span
- Pre-drilled rails and rail splice
- Rails enable easy obstacle management

## Customer-Preferred Aesthetics

- Best-in-class system aesthetics
- Black anodized components
- Low-profile mid clamps and capped, flush end clamps

## Part of Superior System

- Best-in-class system reliability and aesthetics
- Optional rooftop transition flashing, rail-mounted J-box, and wire management rail clips
- Combine with SunPower modules and mySunPower® monitoring app

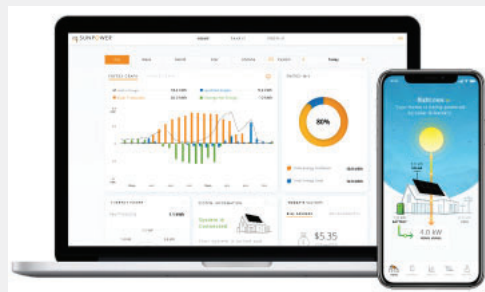

## Elegant Simplicity

SunPower® InvisiMount™ is a SunPower-designed rail-based mounting system. The InvisiMount system addresses residential sloped roofs and combines faster installation time, design flexibility, and superior aesthetics.

Classic InvisiMount is specifically envisioned and engineered to pair with SunPower modules; Universal InvisiMount is compatible with a wide range of modules. The resulting system-level approach amplifies the installation and aesthetic benefits—for homeowners and for installers.



**Intertek**  
5024883  
Conf. To UL STD 2703  
Class A Fire Rating

sunpower.com

# SunPower® InvisiMount™ | Residential Mounting System

## InvisiMount Components



InvisiMount Component Details		
Classic mid clamp	Black oxide stainless steel 300 series	63 g (2.2 oz)
Universal mid clamp	Black anodized aluminum 6000 series	60 g (2.1 oz)
Classic end clamp	Black anodized aluminum 6000 series	110 g (3.88 oz)
Universal end clamp	Black anodized aluminum 6000 series	103 g (3.63 oz)
Rail	Black anodized aluminum 6000 series	830 g/m (9 oz/ft)
Rail splice	Aluminum alloy 6000 series	830 g/m (9 oz/ft)
Rail bolt	M10-1.5 x 25 mm; custom T-head SS304	18 g (0.63 oz)
Rail nut	M10-1.5; DIN 6923 SS304	nominal
Ground lug assembly	SS304; A2-70 bolt; tin-plated copper lug	106.5 g (3.75 oz)
Row-to-row grounding clip	SS 301 with SS 304 M6 bolts	75 g (2.6 oz)
Row-to-row grounding jumper	Stainless steel 300 series	10 g (0.35 oz)
Row-to-row spacer	Black POM-grade plastic	5 g (0.18 oz)

Roof Attachment BOM	
• InvisiMount Comp Shingle Attachment with Pegasus	
• InvisiMount Flat Tile Replacement Attachment with Pegasus	
• InvisiMount S-Tile Replacement Attachment with Pegasus	
• InvisiMount W-Tile Replacement Attachment with Pegasus	

InvisiMount Warranties And Certifications	
Warranties	• 25-year product warranty • 5-year finish warranty
Certifications	• UL 2703 Listed • Class A Fire Rated

InvisiMount Operating Conditions	
Temperature	-40°C to 90°C (-40°F to 194°F)

Roof Attachment Hardware Warranties	
Refer to roof attachment hardware manufacturer's documentation.	

InvisiMount Component LRFD Capacities <sup>2</sup>		
Classic Mid clamp	Uplift	664 lbf
	Shear	540 lbf
Universal Mid clamp	Uplift	962 lb
	Shear	437 lb
Classic End clamp	Uplift	899 lbf
	Shear	220 lbf
Universal End clamp	Uplift	605 lb
	Shear	242 lb
Rail	Moment: upward	548 lbf-ft
	Moment: downward	580 lbf-ft
Rail splice	Moment: upward	548 lbf-ft
	Moment: downward	580 lbf-ft
L-foot	Uplift	1000 lbf
	Shear	390 lbf

<sup>1</sup> With Classic InvisiMount, a module frame that is compatible with the InvisiMount system is required for hardware interoperability; modules without this frame may be used with Universal InvisiMount.

<sup>2</sup> SunPower recommends that all Equinox™, InvisiMount™, and AC module systems always be designed using the InvisiMount Span Tables #524734. If a designer decides to instead use the component capacities listed in this document to design a system, note that the capacities shown are Load and Resistance Factor Design (LRFD) design loads, and are NOT to be used for Allowable Stress Design (ASD) calculations; and that a licensed Professional Engineer (PE) must then stamp all calculations. If you have any questions please contact SunPower Technical Support at 1-855-977-7867.

© 2022 SunPower Corporation. All Rights Reserved. SUNPOWER, the SUNPOWER logo, EQUINOX, and INVISIMOUNT are trademarks or registered trademarks of SunPower Corporation. All other trademarks are the property of their respective owners. Specifications included in this datasheet are subject to change without notice.

sunpower.com  
509506 RevH





# INSTAFLASH™

## Never Deal With Caulking Again!

Factory-installed, non-hardening sealant



**Before InstaFlash Installed:**  
Sealant is contained above roof surface by a protective cage.



**After InstaFlash Installed:**  
Sealant is compressed to fill all holes and voids.

### Protective Cage

Prevents sealant from getting on hands or roof. Collapses upon lag installation.

## Effortless Lifetime Roof Protection

The non-hardening sealant completely fills any missed pilot holes, shingle rips, voids, or other potential water ingress points under the entire footprint of the 4.6" wide base.



### 25-Year Warranty

Manufactured with advanced materials and coatings to outlast the roof itself



### Code Compliant

Fully IBC/CBC Code Compliant Exceeds ASCE 7-16 Standards FL Cert of Approval FL41396 UL2703 Certified



### Self-Healing

The proprietary non-hardening sealant will flex and reseal over years of thermal expansion and contraction



### Larger Spans

The extra-large L-foot and proprietary lag screw result in larger spans between mounts



# INSTAFLASH™

**1**

Drill pilot hole in the center of the rafter using a 7/32" bit.



**2**

Place the InstaFlash over the pilot hole. **Note:** the direction of the InstaFlash Down arrows should point down the roof.



**3**

Insert the lag screw through the center hole into the pilot hole.



**4**

Drive the lag until the InstaFlash is fully seated to the roof.

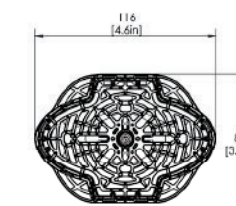
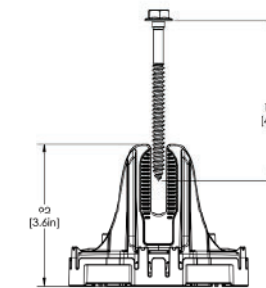
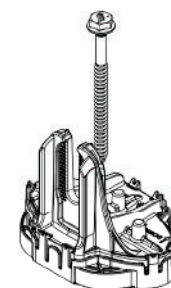

SPECIFICATIONS	INSTAFLASH KITS				
	PIF-RB0	PIF-RBDT	PIF-RBSH	PIF-RM0	PIF-RMDT
Finish	Black			Mill	
Kit Contents	Black InstaFlash, 5/16" x 4.0" SS Lag	Black InstaFlash, 5/16" x 4.0" SS Lag, Dovetail T-bolt w/ Nut	Black InstaFlash, 5/16" x 4.0" SS Lag, M10 Hex Bolt w/ Nut	Mill Insta-Flash, 5/16" x 4.0" SS Lag	Mill InstaFlash, 5/16" x 4.0" SS Lag, Dovetail T-bolt w/ Nut
Attachment Type	Rafter Attached				
Roof Type	Sloped Roof: Composition Shingle, Rolled Asphalt   Flat roof: Modified Bitumen Roof, Built-Up Roof				
Sealant Application	Factory Installed				
Installation Temperature	0°F to 170° F				
Cure Time	Instantly Waterproof; Non-hardening				
Service Temperature	-40°F to 195° F				
Certifications	IBC, ASCE/SEI 7-16, FL Cert of Approval FL41396, TAS 100(A), UL2703				
Install Application	Most Railed Systems, Pegasus Tilt Leg Kit				
Kit Quantity	24				
Boxes per Pallet	36				

US Patents Pending. All rights reserved. ©2023 Pegasus Solar Inc.



SCAN FOR INSTALLATION VIDEO



SCAN FOR FREE TRIAL

# Non-Fusible Switching Devices & Safety Switches

## Product Selection

UL listed File No. E5239

**1**

DG321NRB

### 120/240 Vac General-Duty, Fusible, Single-Throw, continued



System	Ampere Rating	Fuse Type Provision	Maximum Horsepower Ratings ①			NEMA 1 Enclosure Indoor Catalog Number	NEMA 3R Enclosure Rainproof Catalog Number
			Single-Phase AC 120V	240V	Three-Phase AC 240V		
<b>Cartridge Type—Three-Pole, Three-Wire (Three Blades, Three Fuses)—240 Vac</b>							
	30	—	—	—	—	②	②
	60	—	—	—	—	②	②
	100	—	—	—	—	②	②
	200	H	—	15	25-60	DG324FGK ③④	②
	400	H	—	—	50-125	DG325FGK ③④	DG325FRK ③④
	600	H	—	—	75-200	DG326FGK ③④	DG326FRK ③④
<b>Cartridge Type—Four-Wire (Three Blades, Three Fuses, S/N)—120/240 Vac</b>							
	30	H	—	1-1/2-3	3-7-1/2	DG321NGB	DG321NRB
	60	H	—	3-10	7-1/2-15	DG322NGB	DG322NRB
	100	H	—	7-1/2-15	15-30	DG323NGB	DG323NRB
	200	H	—	15	25-60	DG324NGK	DG324NRK
	400	H	—	—	50-125	DG325NGK	DG325NRK
	600	H	—	—	75-200	DG326NGK	DG326NRK

DG322URB

### 120/240 Vac General-Duty, Non-Fusible, Single-Throw



System	Ampere Rating	Maximum Horsepower Ratings			NEMA 1 Enclosure Indoor Catalog Number	NEMA 3R Enclosure Rainproof Catalog Number	
		Single-Phase AC 120V	240V	Three-Phase AC 240V			DC 250V
<b>Two-Pole, Two-Wire (Two Blades)—240 Vac</b>							
	30	2	3	—	—	DG221UGB ④	DG221URB ④
	60	3	10	—	—	DG222UGB ④	DG222URB ④
	100	—	15	—	—	DG223UGB ④	DG223URB ④
	200	—	15	—	—	④⑤	DG224URK ④
<b>Three-Pole, Three-Wire (Three Blades)—240 Vac</b>							
	30	2	3	7-1/2	—	DG321UGB ④	DG321URB ④
	60	3	10	15	—	DG322UGB ④	DG322URB ④
	100	—	15	30	—	DG323UGB ④	DG323URB ④
	200	—	15	60	—	DG324UGK ④	DG324URK ④
	400	—	—	125	—	DG325UGK ④	DG325URK ④
	600	—	—	200	—	DG326UGK ④	DG326URK ④

**Notes**

- ① Maximum hp ratings apply only when dual element time delay fuses are used.
- ② Use four-wire catalog numbers below.
- ③ Solid neutral bars are not included. Order separately from table on Page V2-T1-13.
- ④ **WARNING!** Switch is not approved for service entrance unless a neutral kit is installed.
- ⑤ Use three-wire catalog numbers below.

All general-duty safety switches are individually packaged.

Accessories are limited in scope on general-duty safety switches. See Page V2-T1-13 for availability. In addition, clear line shields are available as an accessory on 200-600A general-duty switches. Catalog Numbers: 200A = 70-7759-11, 400A = 70-8063-8, 600A = 70-8064-8.

# Fusible Switching Devices & Safety Switches

## Product Selection

### 120/240 Vac General-Duty, Fusible, Single Throw

#### Specifications

- 30 – 600 amperes.
- Suitable for service entrance applications unless otherwise noted.
- Horsepower rated.
- Bolt-on hub provision. Provided for general-duty switches in a NEMA 3R enclosure. See Page 8-7 for selection.
- UL listed File No. E5239. Meets UL 98 for enclosed switches and NEMA Std. KS-1.
- 200 – 600 ampere switches incorporate K-Series design.



DP221NGB



DG321NRB

**2**

**Table 8-40. 120/240 Vac General-Duty, Fusible, Single Throw**

System	Ampere Rating	Fuse Type Provision	Maximum Horsepower Ratings ①				NEMA 1 Enclosure Indoor		NEMA 3R Enclosure Rainproof	
			Single-Phase ac		3-Phase ac	dc	Catalog Number	Price U.S. \$	Catalog Number	Price U.S. \$
			120 Volt	240 Volt	240 Volt	250 Volt				

**Fusible — Plug Type ②**

**2-Wire (One Blade, One Fuse, S/N) — 120 Vac**

	30	Plug (Type S, T or W)	1/2-2	—	—	—	—	DP111NGB	—	—	—
--	----	-----------------------	-------	---	---	---	---	----------	---	---	---

**3-Wire (Two Blades, Two Fuses, S/N) — 120/240 Vac**

	30	Plug (Type S, T or W)	1/2-2	1-1/2-3	—	—	—	DP221NGB	—	Use cartridge-type fuse catalog number DG221NRB	—
--	----	-----------------------	-------	---------	---	---	---	----------	---	---	---

**Fusible — Cartridge Type**

**2-Pole 2-Wire (Two Blades, Two Fuses) — 240 Vac**

	30	—	—	1-1/2-3	3-7-1/2	—	③	—	—	③	—
	60	—	—	3-10	7-1/2-15	—	③	—	—	③	—
	100	—	—	7-1/2-15	15-30	—	③	—	—	③	—
	200	—	—	15	25-60	—	③	—	—	③	—
	400	H	—	—	50-125	—	—	DG225FGK ④⑤	—	DG225FRK ④⑤	—
	600	H	—	—	75-200	—	—	DG226FGK ④⑤	—	DG226FRK ④⑤	—

**3-Wire (Two Blades, Two Fuses, S/N) — 120/240 Vac**

	30	H	—	1-1/2-3	3-7-1/2 ⑥	—	—	DG221NGB	—	DG221NRB	—
	60	H	—	3-10	7-1/2-15 ⑥	—	—	DG222NGB	—	DG222NRB	—
	100	H	—	7-1/2-15	15-30 ⑥	—	—	DG223NGB	—	DG223NRB	—
	200	H	—	15	25-60 ⑥	—	—	DG224NGK	—	DG224NRK	—
	400	H	—	—	50-125 ⑥	50	—	DG225NGK	—	DG225NRK	—
	600	H	—	—	75-200 ⑥	—	—	DG226NGK	—	DG226NRK	—

① Maximum hp ratings apply only when dual element time delay fuses are used.

② These switches do not have an interlock which prevents door from being opened when switch is in the ON position.

③ Use 3-wire catalog numbers below.

④ Solid neutral bars are not included. Order separately from Table 8-1 on Page 8-5.

⑤ **WARNING!** Switch is not approved for service entrance unless a neutral kit is installed.

⑥ Grounded B phase rating, UL listed.

**Note:** All general-duty safety switches are individually packaged.

**Note:** Accessories are limited in scope on general-duty safety switches. See Page 8-5 for availability. In addition, clear line shields are available as an accessory on 200 – 600 ampere general-duty switches. Catalog Numbers: 200 A = 70-7759-11, 400 A = 70-8063-8, 600 A = 70-8064-8.



## Eaton CH main lug loadcenter

CH8L125RP

UPC:782114190548

### Dimensions:

- **Height:** 3.69 IN
- **Length:** 13 IN
- **Width:** 11 IN

**Weight:** 12 LB

**Notes:** Ground bar kits priced separately. Suitable for use as service equipment when not more than two service disconnecting mains are provided or when not used as a lighting and appliance panelboard.

### Warranties:

- Limited lifetime

### Specifications:

- **Special Features:** Cover included
- **Type:** Main lug only
- **Amperage Rating:** 125A
- **Box Size:** 7r
- **Bus Material:** Copper
- **Enclosure:** NEMA 3R
- **Enclosure Material:** Metallic
- **Feed Type:** Overhead
- **Main Circuit Breaker:** CH
- **Number Of Circuits:** 8
- **Number Of Wires:** Three-wire
- **Phase:** Single-phase
- **Voltage Rating:** 120/240V, 208Y/120, 240V
- **Wire Size:** #6-1/0 AWG

### Supporting documents:

- [Type CH Circuit Breakers and Loadcenters](#)
- [Loadcenters and Circuit Breakers](#)
- [Eatons Volume 1-Residential and Light Commercial](#)



## Eaton CH main lug loadcenter

CH12L125R

UPC:782113097381

### Dimensions:

- **Height:** 5.19 IN
- **Length:** 16.75 IN
- **Width:** 14.31 IN

**Weight:** 15.8 LB

**Notes:** Suitable for use as service equipment when not more than six service disconnecting mains are provided or when not used as a lighting and appliance panelboard. Rainproof panels are furnished with hub closure plates. For rainproof hubs.

### Warranties:

- Limited lifetime

### Specifications:

- **Special Features:** Cover included
- **Type:** Main lug only
- **Amperage Rating:** 125A
- **Box Size:** B
- **Bus Material:** Copper
- **Enclosure:** NEMA 3R
- **Enclosure Material:** Metallic
- **Feed Type:** Overhead
- **Main Circuit Breaker:** CH
- **Number Of Circuits:** 12
- **Number Of Wires:** Three-wire
- **Phase:** Single-phase
- **Voltage Rating:** 120/240V
- **Wire Size:** #6-2/0 AWG

### Supporting documents:

- [Dimensional Drawing - CH 3/4 LOADCENTER, MAIN LUG ONLY, OUTDOOR NEMA 3R, 120/240 VAC, 1 PH](#)



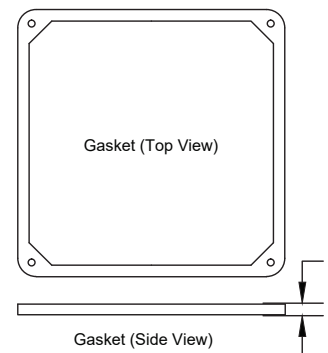
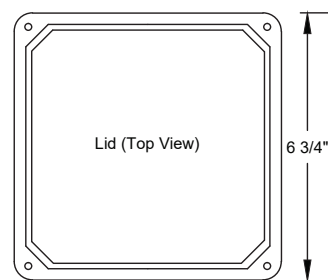
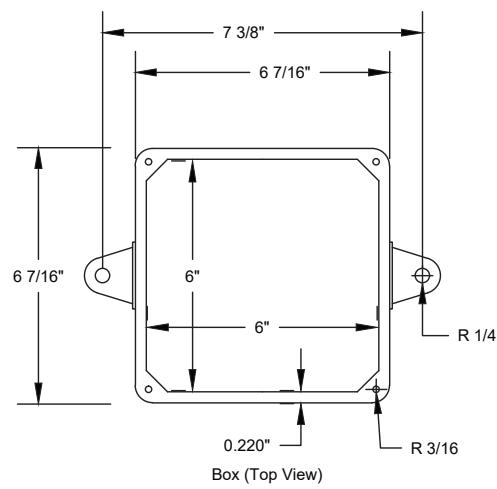
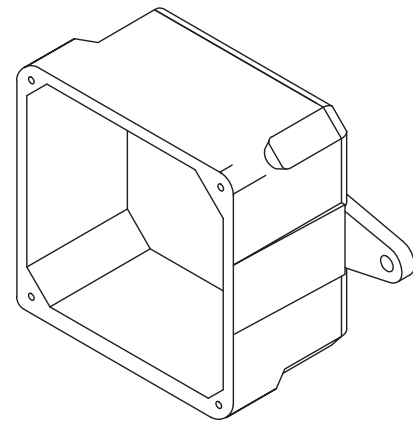
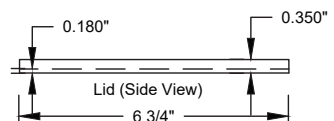
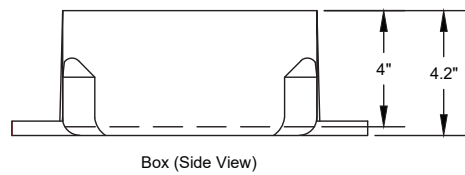

UL Listed  
 Marine Listed  
 UL File # E205935 (QCUP)  
 UL Control # 92CM  
 Material is Rigid PVC  
 132 cu in Volume (2163 cu cm)  
 Screws are Zinc Plated Steel  
 Gasket is neoprene

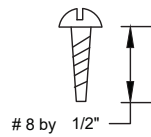

<b>CANTEX</b> INC. Fort Worth, TEXAS		
<b>Junction Box 6 x 6 x 4</b>		
Drawn By: O.M.	Date: 6/19/17	5133710

## 1.4 Listings, Compatibility, and Classification

The SunPower InvisiMount Residential Mounting System is UL 2703 Listed. The InvisiMount Listing **includes** the following modules, which have been tested for grounding and mechanical load with the InvisiMount system.

For Classic InvisiMount certification information, refer to UL at their site <https://www.ul.com> or the at the UL portal <https://www.ul.com/resources/apps/myul-client-portal> and view *File E314938* and *File E466981*. For Universal InvisiMount certification information, refer to Intertek at [https://ramuk.intertekconnect.com/WebClients/ITS/DLP/products.nsf/\\$\\$Search?OpenForm](https://ramuk.intertekconnect.com/WebClients/ITS/DLP/products.nsf/$$Search?OpenForm) and view *Control Number 5024883*.

SunPower DC Modules	SunPower AC Modules	
<ul style="list-style-type: none"> <li>• SPR-A400-BLK-DC</li> <li>• SPR-A400-DC</li> <li>• SPR-A410-DC</li> <li>• SPR-E19-320</li> <li>• SPR-E20-327</li> <li>• SPR-X21-335-BLK</li> <li>• SPR-X21-350-BLK</li> <li>• SPR-X21-345</li> <li>• SPR-X22-360</li> <li>• SPR-X22-370</li> </ul>	<ul style="list-style-type: none"> <li>• SPR-A400-BLK-G-AC</li> <li>• SPR-A390-G-AC</li> <li>• SPR-A400-G-AC</li> <li>• SPR-A410-G-AC</li> <li>• SPR-A415-G-AC</li> <li>• SPR-A425-G-AC</li> <li>• SPR-M415-BLK-H-AC</li> <li>• SPR-M425-BLK-H-AC</li> <li>• SPR-M420-H-AC</li> <li>• SPR-M435-H-AC</li> <li>• SPR-M440-H-AC</li> </ul>	<ul style="list-style-type: none"> <li>• SPR-X22-370-E-AC</li> <li>• SPR-X22-360-E-AC</li> <li>• SPR-X21-350-BLK-E-AC</li> <li>• SPR-X21-335-BLK-E-AC</li> <li>• SPR-X20-327-BLK-E-AC</li> <li>• SPR-X21-345-E-AC</li> <li>• SPR-X21-335-E-AC</li> <li>• SPR-X20-327-E-AC</li> <li>• SPR-E20-327-E-AC</li> <li>• SPR-E19-320-E-AC</li> </ul>

With Universal InvisiMount:

Manufacturer	Module Model / Series
SunPower	<ul style="list-style-type: none"> <li>• SPR-Axxx-COM (may be followed by -BLK), where xxx can be 380–460.</li> <li>• SPR-Axxx-yyy-MLSD, where xxx can be 350–460 and where yyy can be -COM and/or -300 V.</li> </ul>
Aptos	<ul style="list-style-type: none"> <li>• DNA-120-MF26-xxxW, where xxx is wattage.</li> <li>• DNA-108-BF10-xxxW, where xxx is wattage.</li> <li>• DNA-120-BF26-xxxW where xxx is 350–370.</li> </ul>
Hanwha	<ul style="list-style-type: none"> <li>• Q.PEAK DUO BLK ML-G10.a+ xxx, where xxx can be 370–425.</li> </ul>

REC	<ul style="list-style-type: none"> <li>• RECxxxNP2, where xxx can be 350–380.</li> <li>• RECxxxNP2 Black, where xxx can be 350–380.</li> <li>• RECxxxTP4, where xxx can be 350–380.</li> <li>• RECxxxTP4 Black, where xxx can be 350–380.</li> <li>• RECxxxAA, where xxx can be 340–385.</li> <li>• RECxxxAA Black, where xxx can be 340–385.</li> <li>• RECxxxAA Pure, where xxx can be 380–415.</li> </ul>
Trina	<ul style="list-style-type: none"> <li>• TSM-xxxDE06X.05(II), where xxx can be 355–380.</li> </ul>
Jinko	<ul style="list-style-type: none"> <li>• JKMxxxM-6RL3-B, where xxx can be 365–400.</li> </ul>
Canadian Solar	<ul style="list-style-type: none"> <li>• Canadian Solar: CS3NxxxMS where xxx is 380–405.</li> </ul>
Waaree	<ul style="list-style-type: none"> <li>• WSMDi-xxx where xxx is 395–415.</li> </ul>

System Design Load Rating: 10 PSF downward, 5 PSF upward, 5 PSF lateral. Actual system structural capacity is defined by the *InvisiMount Span Tables 524734*.

Grounding from the module to the rail is accomplished through the clamps. See Section 1.5 for more information. The Listing also includes the following components, which have been evaluated for both mounting and bonding in accordance with UL 2703:

- End clamp
- Mid clamp
- Rail
- Splice and splice screw
- Ground lug assembly
- L-foot
- Row-to-row (R2R) grounding clip
- Row-to-row (R2R) grounding jumper
- Row-to-row (R2R) spacer
- Rail-mounted grounding junction box (RMJ)



## SunPower Classic InvisiMount™ Ground Path and Compliance

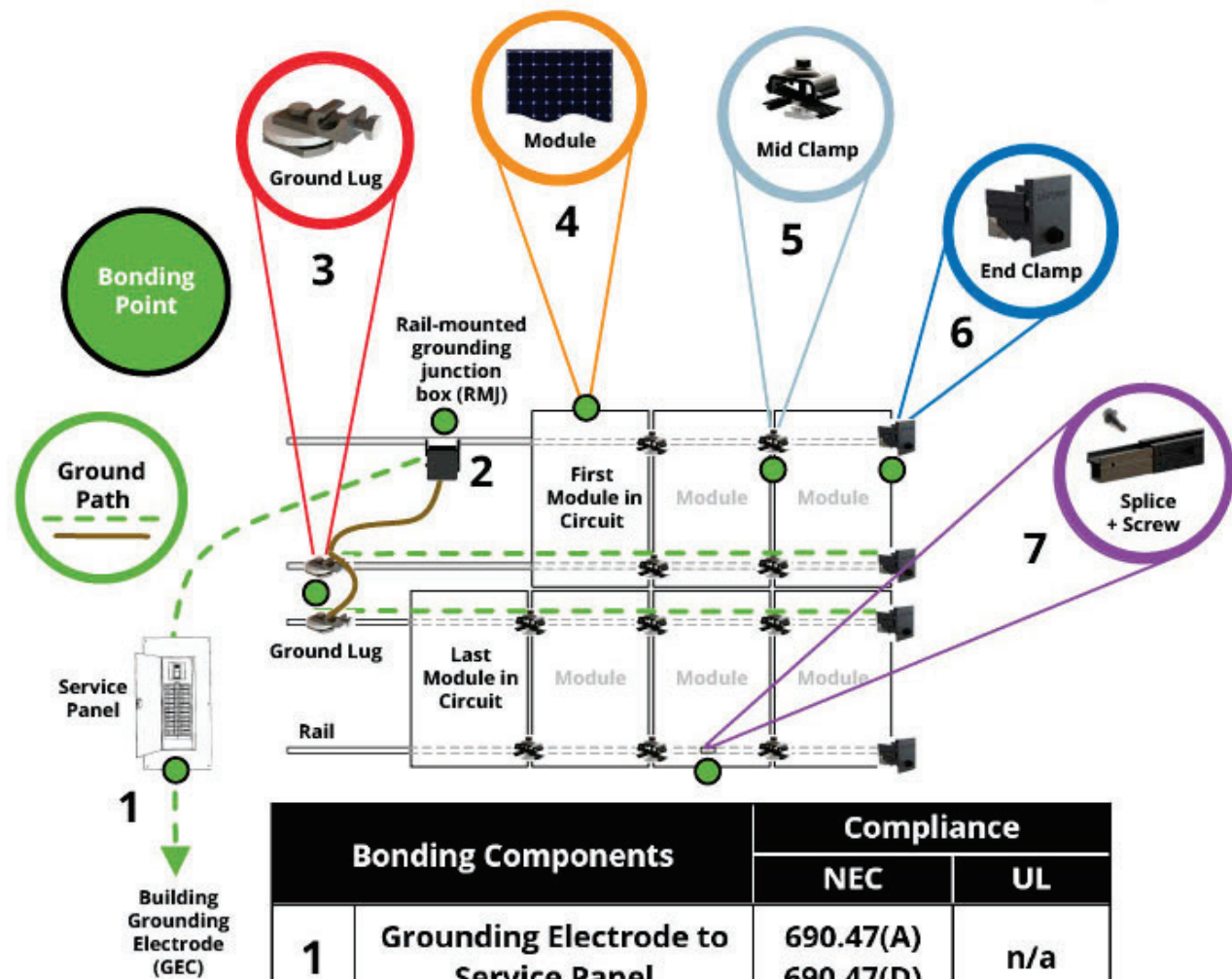

	Bonding Components	Compliance	
		NEC	UL
1	Grounding Electrode to Service Panel	690.47(A) 690.47(D)	n/a
2	Service Panel to Ground Wire	690.43(C)	1741
3	Ground Wire to Ground Lug to Rail	690.43(C)	2703
4	Module Frame	n/a	1703
5	Rail to Mid Clamp to Module Frame	690.43(A) 690.43(C) 690.43(D)	2703
6	Module Frame to End Clamp to Rail	690.43(A) 690.43(C) 690.43(D)	2703
7	Rail to Splice	690.43(A) 690.43(C) 690.43(D)	2703

## SunPower Classic InvisiMount™ with R2R Grounding Clip Ground Path and Compliance

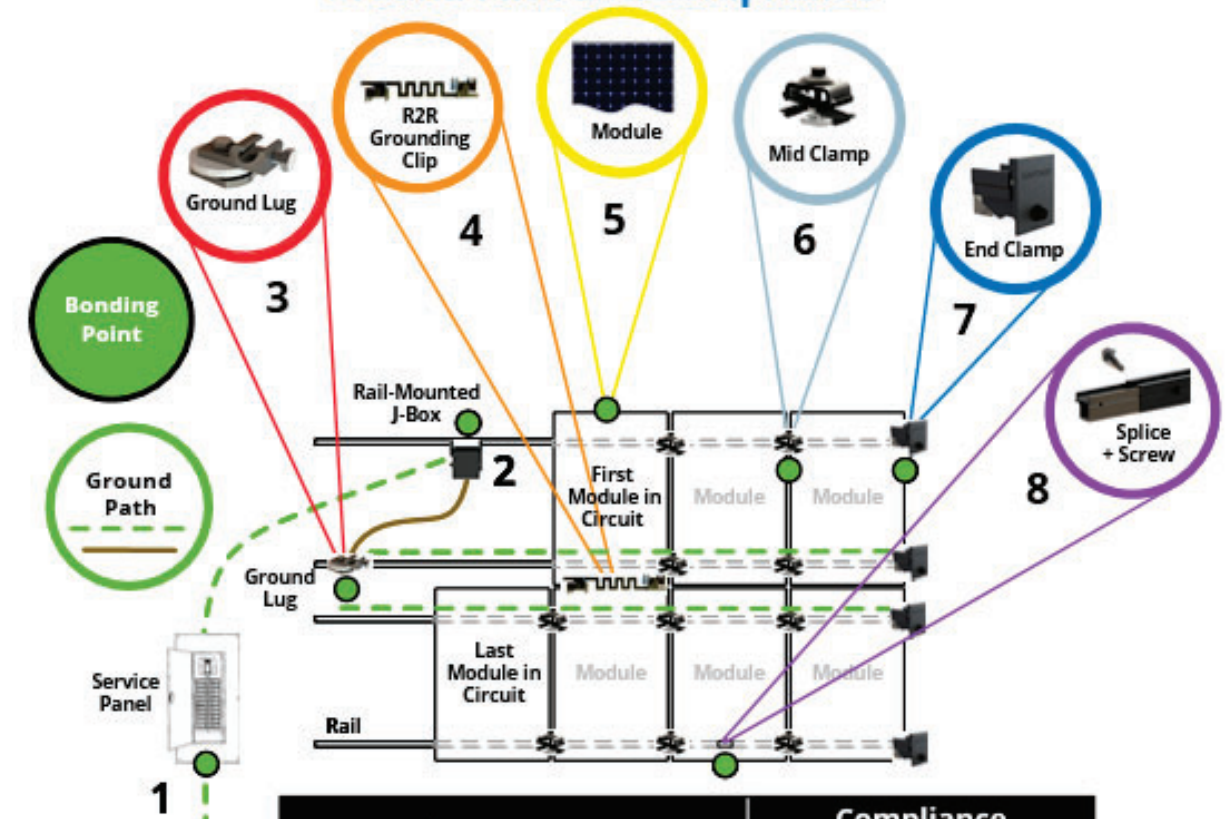

	Bonding Components	Compliance	
		NEC	UL
1	Grounding Electrode to Service Panel	690.47(A) 690.47(D)	n/a
2	Service Panel to Ground Wire	690.43(C)	1741
3	Ground Wire to Ground Lug to Rail	690.43(C)	2703
4	Module Frame to Module Frame	690.43(C)	2703
5	Module Frame	n/a	1703
6	Rail to Mid Clamp to Module Frame	690.43(A) 690.43(C) 690.43(D)	2703
7	Module Frame to End Clamp to Rail	690.43(A) 690.43(C) 690.43(D)	2703
8	Rail to Splice	690.43(A) 690.43(C) 690.43(D)	2703

# Powerwall 3

## Power Everything

Powerwall 3 is a fully integrated solar and battery system, designed to accelerate the transition to sustainable energy. Customers can receive whole home backup, cost savings, and energy independence by producing and consuming their own energy while participating in grid services. Once installed, customers can manage their system using the Tesla App to customize system behavior to meet their energy goals.

Powerwall 3 achieves this by supporting up to 20 kW DC of solar and providing 11.5 kW AC of continuous power per unit. It has the ability to start heavy loads up to 185 A LRA, meaning a single unit can support the power needs of most homes. Powerwall 3 is designed for mass production, fast and efficient installations, easy system expansion, and simple connection to any electrical service.



# Powerwall 3 Technical Specifications

System Technical Specifications	Model Number	1707000-xx-y
	Nominal Grid Voltage (Input & Output)	120/240 VAC
	Grid Type	Split phase
	Frequency	60 Hz
	Overcurrent Protection Device	Configurable up to 60 A
	Solar to Battery to Home/Grid Efficiency	89% <sup>1,2</sup>
	Solar to Home/Grid Efficiency	97.5% <sup>3</sup>
	Supported Islanding Devices	Backup Gateway 2, Backup Switch
	Connectivity	Wi-Fi (2.4 and 5 GHz), Dual-port switched Ethernet, Cellular (LTE/4G <sup>4</sup> )
	Hardware Interface	Dry contact relay, Rapid Shutdown (RSD) certified switch and 2-pin connector, RS-485 for meters
	AC Metering	Revenue Grade (+/- 0.5%)
	Protections	Integrated arc fault circuit interrupter (AFCI), Isolation Monitor Interrupter (IMI), PV Rapid Shutdown (RSD) using Tesla Mid-Circuit Interrupters
	Customer Interface	Tesla Mobile App
Warranty	10 years	

Solar Technical Specifications	Maximum Solar STC Input	20 kW
	Withstand Voltage	600 V DC
	PV DC Input Voltage Range	60 – 550 V DC
	PV DC MPPT Voltage Range	150 – 480 V DC
	MPPTs	6
	Maximum Current per MPPT ( $I_{mp}$ )	13 A <sup>5</sup>
Maximum Short Circuit Current per MPPT ( $I_{sc}$ )	15 A <sup>5</sup>	

Battery Technical Specifications	Nominal Battery Energy	13.5 kWh AC <sup>2</sup>
	Maximum Continuous Discharge Power	11.5 kW AC
	Maximum Continuous Charge Power	5 kW AC
	Output Power Factor Rating	0 - 1 (Grid Code configurable)
	Maximum Continuous Current	48 A
	Maximum Output Fault Current	10 kA
	Load Start Capability (1 s)	185 A LRA
	Power Scalability	Up to 4 Powerwall 3 units supported

<sup>1</sup> Typical solar shifting use case.

<sup>2</sup> Values provided for 25°C (77°F), at beginning of life. 3.3 kW charge/discharge power.

<sup>3</sup> Tested using CEC weighted efficiency methodology.

<sup>4</sup> Cellular connectivity subject to network service coverage and signal strength.

<sup>5</sup> Where the DC input current exceeds the MPPT rating, a jumper can be used to combine two MPPTs into a single input to intake DC current up to 26 A  $I_{mp}$  / 30 A  $I_{sc}$ .



## Powerwall 3 Technical Specifications

### Environmental Specifications

Operating Temperature	-20°C to 50°C (-4°F to 122°F) <sup>6</sup>
Operating Humidity (RH)	Up to 100%, condensing
Storage Temperature	-20°C to 30°C (-4°F to 86°F), up to 95% RH, non-condensing, State of Energy (SOE): 25% initial
Maximum Elevation	3000 m (9843 ft)
Environment	Indoor and outdoor rated
Enclosure Rating	NEMA 3R
Ingress Rating	IP67 (Battery & Power Electronics) IP45 (Wiring Compartment)
Pollution Rating	PD3
Operating Noise @ 1 m	< 50 db(A) typical < 62 db(A) maximum

<sup>6</sup> Performance may be de-rated at operating temperatures above 40°C (104°F).

### Compliance Information

Certifications	UL 1642, UL 1699B, UL 1741, UL 1741 SA, UL 1741 SB, UL 1741 PCS, UL 3741, UL 1973, UL 1998, UL 9540, IEEE 1547-2018, IEEE 1547.1, UN 38.3
Grid Connection	United States
Emissions	FCC Part 15 Class B
Environmental	RoHS Directive 2011/65/EU
Seismic	AC156, IEEE 693-2005 (high)
Fire Testing	Meets the unit level performance criteria of UL 9540A

### Mechanical Specifications

Dimensions	1099 x 609 x 193 mm (43.25 x 24 x 7.6 in)
Weight	130 kg (287 lb)
Mounting Options	Floor or wall mount

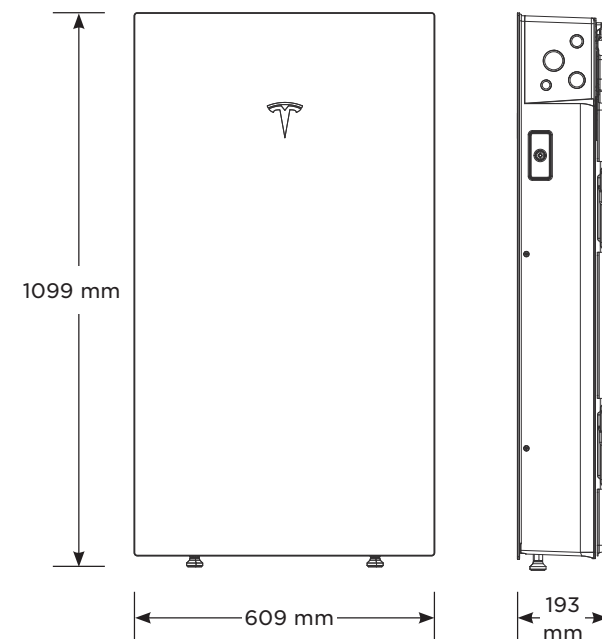

## Solar Shutdown Device Technical Specifications

The Solar Shutdown Device is a Mid-Circuit Interrupter (MCI) and is part of the PV system rapid shutdown (RSD) function in accordance with Article 690 of the applicable NEC. When paired with Powerwall 3, solar array shutdown is initiated by any loss of AC power.

### Electrical Specifications

Model	MCI-1	MCI-2
Nominal Input DC Current Rating ( $I_{MP}$ )	13 A	13 A
Maximum Input Short Circuit Current ( $I_{SC}$ )	19 A	17 A
Maximum System Voltage (PVHCS)	600 V DC	1000 V DC <sup>7</sup>

<sup>7</sup> Maximum System Voltage is limited by Powerwall to 600 V DC.

### RSD Module Performance

Maximum Number of Devices per String	5	5
Control	Power Line Excitation	Power Line Excitation
Passive State	Normally Open	Normally Open
Maximum Power Consumption	7 W	7 W
Warranty	25 years	25 years

### Environmental Specifications

Operating Temperature	-40°C to 50°C (-40°F to 122°F)	-45°C to 70°C (-49°F to 158°F)
Storage Temperature	-30°C to 70°C (-22°F to 158°F)	-30°C to 70°C (-22°F to 158°F)
Enclosure Rating	NEMA 4X / IP65	NEMA 4X / IP65

### Mechanical Specifications

Electrical Connections	MC4 Connector	MC4 Connector
Housing	Plastic	Plastic
Dimensions	125 x 150 x 22 mm (5 x 6 x 1 in)	173 x 45 x 22 mm (6.8 x 1.8 x 1 in)
Weight	350 g (0.77 lb)	120 g (0.26 lb)
Mounting Options	ZEP Home Run Clip M4 Screw (#10) M8 Bolt (5/16") Nail / Wood screw	Wire Clip

### Compliance Information

Certifications	UL 1741 PVRSE, UL 3741, PVRSA (Photovoltaic Rapid Shutdown Array)
RSD Initiation Method	External System Shutdown Switch or Powerwall 3 Enable Switch

### UL 3741 PV Hazard Control (and PVRSA) Compatibility

See Powerwall 3 Installation Manual



# Backup Gateway 2

Backup Gateway 2 controls connection to the grid when paired with Powerwall 3, automatically detecting outages and providing seamless transition to backup power. Backup Gateway 2 also provides energy metering for solar self-consumption, time-based control, and backup operation.

In this system configuration, Powerwall 3 acts as the Site Controller, with the Backup Gateway 2 Site Controller disabled.

<b>Performance Specifications</b>	<b>Model Number</b>	1232100-xx-y	<b>User Interface</b>	Tesla App
	<b>AC Voltage (Nominal)</b>	120/240 V	<b>Operating Modes</b>	Support for solar self-consumption, time-based control, and backup
	<b>Feed-in Type</b>	Split phase	<b>Backup Transition</b>	Automatic disconnect for seamless backup
	<b>Grid Frequency</b>	60 Hz	<b>Modularity</b>	Supports up to 10 AC-coupled Powerwalls
	<b>Current Rating</b>	200 A	<b>Optional Internal Panelboard</b>	200 A 6-space / 12 circuit breakers Siemens QP or Square D HOM breakers rated 10 - 80A or Eaton BR breakers rated 10 - 125A
	<b>Maximum Supply Short Circuit Current</b>	10 kA <sup>8</sup>	<b>Warranty</b>	10 years
	<b>Overcurrent Protection Device</b>	100 - 200 A, Service entrance rated <sup>9</sup>	<sup>10</sup> When protected by Class J fuses, Backup Gateway 2 is suitable for use in circuits capable of delivering not more than 22kA symmetrical amperes.	
	<b>Overvoltage Category</b>	Category IV	<sup>11</sup> The customer is expected to provide internet connectivity for Backup Gateway 2; cellular should not be used as the primary mode of connectivity. Cellular connectivity subject to network operator service coverage and signal strength.	
	<b>Internal Primary AC Meter</b>	Revenue accurate (+/- 0.2%)		
	<b>Internal Auxiliary AC Meter</b>	Revenue accurate (+/- 2%)		
<b>Primary Connectivity</b>	Ethernet, Wi-Fi			
<b>Secondary Connectivity</b>	Cellular (3G, LTE/4G) <sup>10</sup>			

<b>Environmental Specifications</b>	<b>Operating Temperature</b>	-20°C to 50°C (-4°F to 122°F)
	<b>Operating Humidity (RH)</b>	Up to 100%, condensing
	<b>Maximum Elevation</b>	3000 m (9843 ft)
	<b>Environment</b>	Indoor and outdoor rated
	<b>Enclosure Type</b>	NEMA 3R

<b>Compliance Information</b>	<b>Certifications</b>	UL 67, UL 869A, UL 916, UL 1741 PCS, CSA 22.2 0.19, CSA 22.2 205
	<b>Emissions</b>	FCC Part 15, ICES 003

<b>Mechanical Specifications</b>	<b>Dimensions</b>	660 x 411 x 149 mm (26 x 16 x 6 in)
	<b>Weight</b>	20.4 kg (45 lb)
	<b>Mounting options</b>	Wall mount, Semi-flush mount

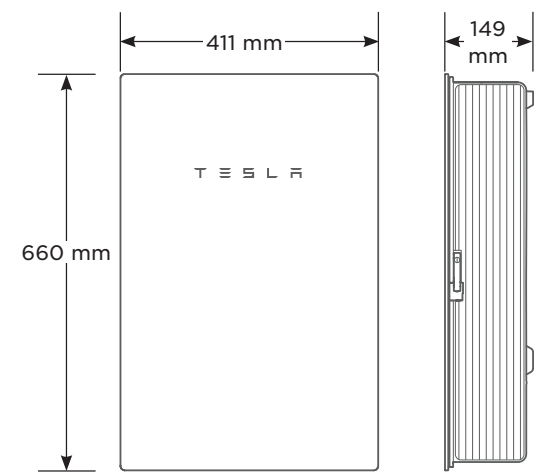

July 29, 2022

To whom it may concern,

This letter confirms and attests that:

SPWR-A5 is equivalent to Enphase Models:

IQ7HS-66-ACM-US, 369 VA, 208Vac Grid Support Utility Interactive Inverter  
IQ7HS-66-E-ACM-US, 369 VA, 208Vac Grid Support Utility Interactive Inverter  
IQ7HS-66-M-US, 369 VA, 208Vac Grid Support Utility Interactive Inverter  
IQ7HS-66-ACM-US, 384 VA, 240Vac Grid Support Utility Interactive Inverter  
IQ7HS-66-E-ACM-US, 384 VA, 240Vac Grid Support Utility Interactive Inverter  
IQ7HS-66-M-US, 384 VA, 240Vac Grid Support Utility Interactive Inverter

Regards,



Aranjit Sangha  
Senior Staff Engineer  
Enphase Energy Inc.  
1420 North McDowell Blvd.  
Petaluma, CA 94954  
v: (707) 763-4784 x7098  
asangha@enphaseenergy.com



4801 Freidrich Ln, Suite 100  
Austin, TX 78744  
1-800-504-2337  
www.freedomsolarpower.com

July 3, 2024

RE: BILLY H RIGGSBEE(Customer) Residence  
Solar PV Installation  
10 BRADDOCK DRIVE  
LILLINGTON, NORTH  
CAROLINA, 27546

To Whom it May Concern,

The PV system with Tesla Powerwall 3 will have a site export limit established at the time of install. The site export limit can only be adjusted by qualified personnel, therefore the customer will not have access to these settings. Please see the attached Tesla application notes for more information on the Powerwall 3 export limiting features. Below are the specific settings that will be applied to this system.

Inverter Model: Tesla Powerwall 3 1707000-xx-y  
Default Output: 3.784 kW AC

Tesla Powerwall 3 Site Export Setting To Be Applied: Solar Only  
Export Limit: 13.000 kW AC

Sincerely,

A handwritten signature in blue ink that reads "Joshua Meade".

---

Josh Meade, P.E.  
Lead Designer | Freedom Solar





## Power Control System (PCS) Features for Powerwall Systems



---

1 Overview.....	2
1.1 Glossary.....	3
1.2 Site Controller Software.....	4
1.3 Feature Configuration Overview.....	4
2 Compliance Requirements.....	5
2.1 Plan Set Labeling Requirements.....	5
2.2 Panel Labeling Requirements.....	6
2.3 CT Labeling Requirements.....	6
2.4 Important Notes on UL 1741 PCS Compliance.....	7
3 Panel Limit Feature.....	9
4 Site Limit Feature.....	14
5 Conductor Limit Feature.....	20
6 Appendix A: Powerwall+ and Powerwall 3 Permanent Non-Export.....	25
7 Revision History.....	29



# 1 Overview

Powerwall is managed by a software platform that allows the system to provide grid services, economic returns, and energy security while maintaining system limits. System limits can vary depending on the connection of the Powerwall, the electrical infrastructure on site, and the interconnection of the system.

Power Control System (PCS) is a type of Energy Management System (EMS) and is a term used by UL 1741, NEC, and Tesla to refer to software controls of production sources (Solar & Battery) to maintain system limits. PCS software can limit the power of a Powerwall system to safely interconnect with a variety of home electrical system ratings. As a result, PCS can help avoid expensive electrical upgrades, complicated load relocation, or a reduction in system performance.

 **NOTE:** PCS features are on-grid controls; controls such as frequency shifting are only available during a grid outage and are not considered part of PCS, and as such are not part of the scope of this document.

UL1741 CRD for PCS and NEC 705.13 (introduced in 2020 revision) outline a variety of requirements that a system must provide to be qualified as a Power Control System (PCS). Tesla has implemented software in accordance with these standards. PCS is implemented after review of system risks to ensure that the PCS controls, when combined with traditional design methodology and overcurrent protection, will ensure safe and effective system operation. Tesla has reviewed the behavior of all parts of the system to ensure a proper response even during a loss of communication or a hardware failure.

Power Control System (PCS) methodology and implementation can be used to manage a system to enforce the following limits:

- **Site Limit:** To prevent excess Import/Export through the site meter to/from the utility connection
- **Conductor Limit:** To prevent excess current through specific monitored and controlled conductors
- **Panel Limit:** To prevent excess current experienced by a virtual panel, fed by a sum of site, solar, and batteries

 **NOTE:** Site, Conductor, and Panel Limits are all types of PCS. These terms are distinct and specific features of Tesla's overall suite of PCS controls.

Tesla and a Nationally Recognized Testing Laboratory (NRTL) have certified the Power Control System implementation for all three of these features to standards set forth in UL1741-CRD-PCS for 240V split-phase grid services up to 200A with Backup Switch or Backup Gateway 2.

For installations in accordance with NEC 2020 or newer, this document can be shared alongside the relevant NRTL-certified PCS VoC (available on Partner Portal) to the appropriate AHJ (Authority Having Jurisdiction) to support the inspection, permitting, and interconnection process.





## 1.1 Glossary

<b>Energy Management System (EMS)</b>	Term used in NEC to refer to the software controls of production sources (Solar & Battery) to maintain system limits
<b>Power Control System (PCS)</b>	Term used by UL 1741, NEC, and Tesla to refer to the software controls of production sources (Solar & Battery) to maintain system limits. PCS is a type of Energy Management System (EMS)
<b>Powerwall</b>	Powerwall is a rechargeable home battery, also called a battery energy storage system (BESS). Powerwall has an integrated energy meter and performs its own battery metering
<b>Qualified Personnel</b>	A Tesla installer or Certified Installer who has the skills and knowledge related to installation and operation of electrical equipment to recognize and avoid the hazards involved
<b>Site Limit</b>	Prevents excess Import and/or Export through the site meter from/to the utility connection
<b>Conductor Limit</b>	Prevents excess current through specific monitored and controlled conductors
<b>Panel Limit</b>	Prevents excess current experienced by a virtual panel, fed by a sum of site, solar, and batteries
<b>Grid</b>	Measured by one or more physical site meters to measure the full current flowing into the virtual panel from the grid
<b>Uncontrolled Sources</b>	Any equipment not connected over direct communication, including standalone solar inverters or similar sources to the virtual panel
<b>Controlled Sources</b>	Any equipment connected over direct communication, including Tesla Powerwall 2, Tesla Powerwall+, and/or Tesla Powerwall 3 in any quantity and combination (e.g. one Powerwall+ and two Powerwall 2) that can be current limited
<b>Virtual Panel</b>	May include several panels and conductors, and is considered as one single panel with respect to the Panel Limit feature. As there may be more than one physical panel and conductors included, the Panel Limit is set to the rating of the smallest busbar within the “Virtual Panel”
<b>Energy Meter</b>	Measures voltage and current to calculate net power flow. Energy meters can be of type Site, Solar, Conductor, or Load. See the <a href="#">Residential Energy Metering Guide</a> for more information about meter types
<b>Current Transformer (CT)</b>	Installed around conductors to monitor the current flowing through them. CTs are connected to an energy meter, which uses the current measurement to calculate how much power is being produced or consumed
<b>Site Controller</b>	Tesla’s Site Controller is the computer that coordinates site functions like charging, discharging, self-consumption, power control, etc. All Powerwall systems have a Site Controller
<b>Meter X</b>	Built-in meter in the Backup Gateway 2. Its CTs cannot be relocated
<b>Meter Y</b>	Built-in meter in the Backup Gateway 2 with three CT terminals. Tesla CTs are installed and connected to Meter Y
<b>Meter Z</b>	Built-in meter in Backup Switch. Its CTs cannot be relocated



<b>Remote Energy Meter</b>	Third party meters that can be installed and paired with the Site Controller for additional metering capability. Neurio W1 and W2 meters are both supported Remote Energy Meters
----------------------------	--

## 1.2 Site Controller Software

The “Panel Limits,” “Site Limits,” and “Conductor Limits” features are implemented in the Tesla Site Controller software, which operates on the Backup Gateway 2, the Powerwall+, or the Powerwall 3, depending on system configuration. Tesla’s Site Controller software is used across all Tesla Powerwall sites. Site Controller software controls the entire energy storage site and communicates over CAN and Wi-Fi. The Backup Switch or Backup Gateway and Remote Energy Meter(s) (if present) are part of a Powerwall system and contain current sensor(s) per phase as needed, to act as a Site and/or Solar meter, which measure the grid and uncontrolled power production sources.

This software is listed to the requirements in UL 1741 PCS and compliant with Article 705.13 of the 2020 and 2023 NEC, as described in [Important Notes on UL 1741 PCS Compliance on page 7](#).

## 1.3 Feature Configuration Overview

This document introduces each of the following settings in more detail; this table provides a simple reference for which users can configure each feature.

Feature	Description	Configurable By
<b>Panel Limit (numerical limit)</b>	Limit on amperage flowing into an electric panel / busbar from all controlled and uncontrolled sources (Grid, Solar Inverter, and Powerwall)	Default limit is 80A for Powerwall 2, Powerwall+ or Powerwall 3. Can be configured to 10-200A by Qualified Personnel
<b>Site Import Permissions (style of import)</b>	Whether Powerwall can charge from solar, the grid, or both	Qualified Personnel
<b>Site Import Limit (numerical limit)</b>	Limit on how much the site can import from the grid	Qualified Personnel
<b>Site Export Permissions (style of export)</b>	Whether the Powerwall and/or solar can export to the grid	Qualified Personnel
<b>Site Export Limit (numerical limit)</b>	Limit on how much power can be exported to the grid	Qualified Personnel
<b>Conductor Limits (numerical limit)</b>	Curtails power from all Powerwalls in a system to limit the total current on a conductor, making the limit equivalent to the “power source(s) output circuit current” outlined in the requirements of Article 705.12(B) of the NEC / CEC	Qualified Personnel



## 2 Compliance Requirements

UL 1741 PCS compliance may be required by the interconnecting utility or Authority Having Jurisdiction (AHJ), also called the site host. If UL 1741 PCS compliance is required according to applicable site design, follow the guidance in this section.

The Powerwall and controlled solar system is UL 1741 PCS-compliant with the following nominal voltages:

- 240V (Split Phase)

Compliance with UL 1741 PCS can be achieved for system sizes up to and including 200A with a Backup Switch or Backup Gateway 2 according to the requirements below.

### 2.1 Plan Set Labeling Requirements

All PCS-controlled conductors and busbars shall be indicated on the single line diagram on the plan set.

Figure 1. Controlled Conductors Labeled on Example Single Line Diagram

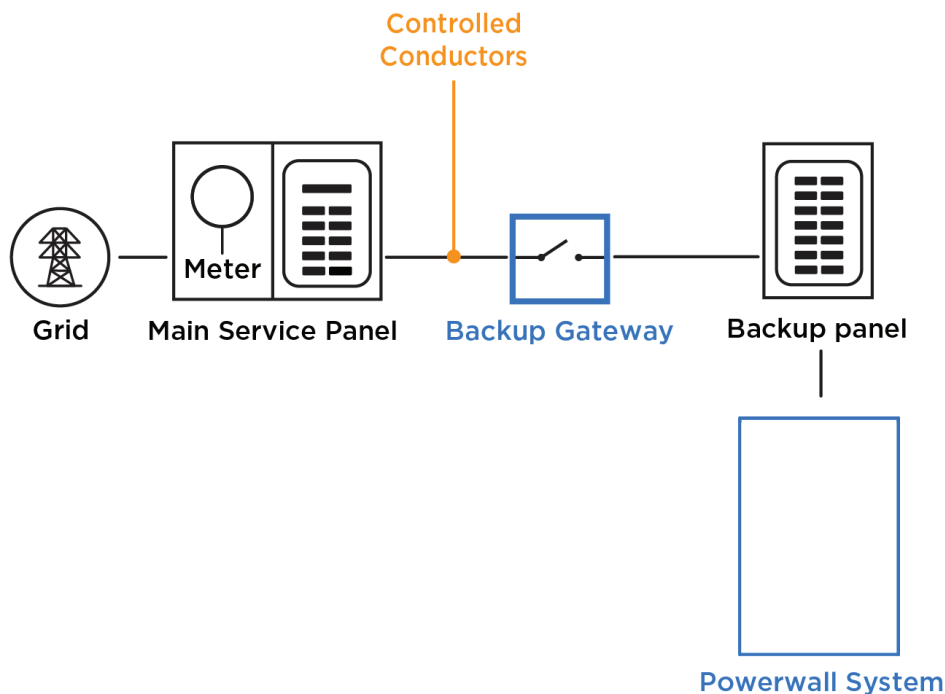





## 2.2 Panel Labeling Requirements

The PCS-controlled current setting for all panels within the controlled system shall be indicated with a field-applied marking label on the conductor or in close proximity to the panel. Refer to the label below, filling the blank with the appropriate value:

Figure 2. PCS Field Marking Label

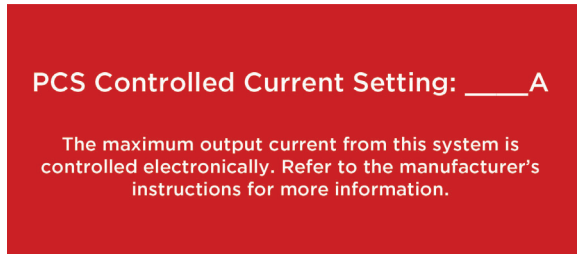

## 2.3 CT Labeling Requirements

The following label must be posted near the installation of CT(s):

- For **Panel Limits**, label all Site and Solar CTs (may include Backup Gateway 2 (Meter X and Meter Y) CTs, Backup Switch (Meter Z), and/or Remote Energy Meter CTs, excluding CTs installed for Revenue Grade Metering).
- For **Site Limits**, label all Site CTs (may include Backup Gateway 2 (Meter X and Meter Y) CTs, Backup Switch (Meter Z), and/or Remote Energy Meter CTs).
- For **Conductor Limits**, label all Conductor CTs (may include Backup Gateway 2 (Meter X or Meter Y) CTs or Remote Energy Meter CTs).

Figure 3. CT Field Marking Label

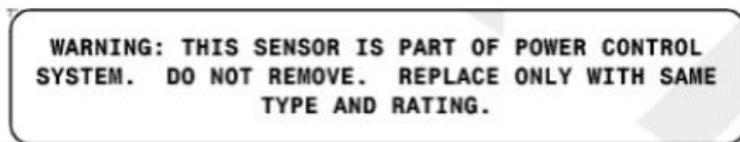





## 2.4 Important Notes on UL 1741 PCS Compliance

 **NOTE:** A system equipped with a Power Control System (PCS) must be suitably rated to provide branch circuit overcurrent protection. The controlled current setting shall not exceed the rating of any controlled panels or conductor ampacity.

 **WARNING:** Configuration of Power Control System settings or changes to settings shall be made by Qualified Personnel only. Incorrect configuration or setting of the power control settings may result in unsafe conditions.

 **NOTE:** Maximum PCS Controlled Current setting: 200 A.

 **NOTE:** The maximum operating currents in controlled busbars or conductors are limited by the settings of the Power Control System (PCS) and may be lower than the sum of the currents of the connected controlled power sources. The settings of the PCS controlled currents may be used for calculation of the design currents used in the relevant sections of NEC Article 690 and 705.

### 2.4.1 Monitoring (2020 NEC, 705.13 (A), UL 1741 PCS)

- Tesla Site Controller receives meter data from the Backup Switch (Meter Z) or Backup Gateway 2 (Meter X and/or Meter Y), and/or Remote Energy Meter(s).
- Tesla Site Controller receives controlled current data of the AC output of the Powerwall and controlled solar.
- Each limit is monitored by a metering device as follows:
  - Panel Limits are monitored by adding together the current flowing into the Virtual Panel (net current from Site, Solar, and Battery). The limit is enforced on the sum of all phases.
  - Site Limits are monitored by the sum of all Site meters. The limit is enforced on the sum of all phases.
  - Conductor Limits are monitored by each Conductor meter. The limit is enforced on each phase independently.
- Where communications are lost with the relevant meter(s), all controlled power production sources are curtailed.

### 2.4.2 Settings (2020 NEC 705.13(B), 2023 NEC 750.30(C)(1), UL 1741 PCS 201.9)

- Each default is as follows:
  - Panel Limits by default are automatically configured with an 80A Panel Limit for all Powerwall 2, Powerwall+, and Powerwall 3 installations. As 100A is the minimum allowable size for a single family dwelling per NEC 230.79 (C), this protects any main panel busbar for a single family dwelling with any quantity of Tesla Powerwalls (80A is 80% of the 100A minimum service size).

 **NOTE:** The minimum allowable size for multifamily dwellings is 60A, and downstream subpanels may also be smaller than 100A.

- Site Import Permissions are by default set to allow charging from grid. However, charge from grid can only be enabled by the customer in their Tesla app. Unless the customer sets *Grid Charging* to **Yes**, the system will not charge from grid.
- Site Export Permissions are by default set to allow solar-only export.
- Site Limits are not set by default.



- Conductor Limits are not set by default.
- The PCS limits can be verified by viewing the Summary page in the Setup App.

### **2.4.3 Overcurrent Protection (2020 NEC 705.13(C) and UL 1741 PCS 201.2)**

- The Tesla Site Controller software is certified under UL 1741 PCS as secondary overcurrent protection.
- Overcurrent protection devices are still required for each circuit as required by the National Electrical Code.
- Overcurrent protection devices shall be sized in accordance with the ratings of conductors, panels, and related equipment as required by the National Electrical Code.
- Software manages the output of the battery and controlled solar in a best effort approach to prevent exceeding each of the configured limits.
  - For Panel Limits, software curtails battery and/or controlled solar to prevent exceeding the configured limits.
  - For Site Limits, software both curtails battery and/or controlled solar, and compensates by having Powerwall charge or discharge to prevent exceeding the configured limits.
  - For Conductor Limits, software both curtails battery and/or controlled solar, and compensates by having Powerwall charge or discharge to prevent exceeding the configured limits.
  - Once battery and controlled solar have been curtailed, or if they have no additional power or energy with which to compensate for loads, the balance is fed from the grid.
  - Accordingly, breakers should be sized to protect all conductors, busbars, and equipment on site, as intended prior to the addition of secondary power sources.

### **2.4.4 Single Power Source Rating (2020 NEC 705.13(D) and UL 1741 PCS 201.9)**

- Each Powerwall 2 connection to the electrical panel requires an independent 30 A circuit breaker.
- Each Powerwall+ connection to the electrical panel requires an independent 50 A circuit breaker.
- Each Powerwall 3 connection to the electrical panel requires an independent 60 A circuit breaker.
- This breaker serves as the disconnect for the unit and must be wired in accordance with local wiring codes and regulations.
- This breaker is by design smaller than the smallest panel used within the system.
- The service disconnect overcurrent rating can remain unchanged through the use of the PCS.

### **2.4.5 Access to Settings (2020 NEC 705.13(E), 2023 NEC 750.30(C)(3), UL 1741 PCS 208.1(F))**

- Panel Limits, Site Limits, and/or Conductor Limits can be configured by Qualified Personnel (Tesla or Certified Installers) in the Tesla Pros app, which is password-protected.
  - For Panel Limits, a limit of 80A is auto-enabled for all Powerwall 2, Powerwall+, and Powerwall 3 systems. Qualified Personnel can change this limit in the Tesla Pros app.





### 3 Panel Limit Feature

#### 3.1 Feature Overview

As per the requirement from NEC: 2020, 705.13, Tesla Site Controller software has implemented a Panel Limit feature that monitors the amperage flowing into and out of an electrical panel / busbar from all controlled and uncontrolled sources (Grid, Solar Inverter, and Powerwall). As the measured current approaches the configured Panel Limit, the Site Controller first reduces the current contribution of batteries (at 90% of the Limit), then limits the output of controlled solar (at 95% of the Limit). If the measured current of all sources combined exceeds the configured Panel Limit for the site, the output of all PCS-controlled power production sources will be curtailed to 0.

For the purposes of Panel Limits, the Site Controller treats all metered values as positive, including Site export and Battery charging. The result is that the Panel Limit effectively behaves like a Site Export and Import Limit, as it prevents the controlled sources from contributing to an import or export value that is greater than the Panel Limit. If this behavior presents an issue for the system, and a Panel Limit is not required for busbar protection, the Panel Limit can be disabled (see *Configuring Panel Limits* below).

As detailed in [Site Limit Feature on page 14](#), Site Import and Export Limits are useful when a utility enforces restrictions on the maximum power that can be sent in one direction or the other, and requires proof that those restrictions are being followed. Site Import and Export Limits also provide the following “best-effort” behavior that is not present in Panel Limits:

- The Site Import Limit will cause Powerwalls to discharge to try to avoid exceeding the limit, if the Powerwalls are able to discharge.
- The Site Export Limit will cause Powerwalls to charge to try to avoid exceeding the limit, if the Powerwalls are able to charge.

 **NOTE:** All current flowing to the loads will be fed from the grid supply, along with any sources uncontrolled by the Tesla Site Controller (which in turn need to be sized in accordance with the 120% rule or their own PCS controls).

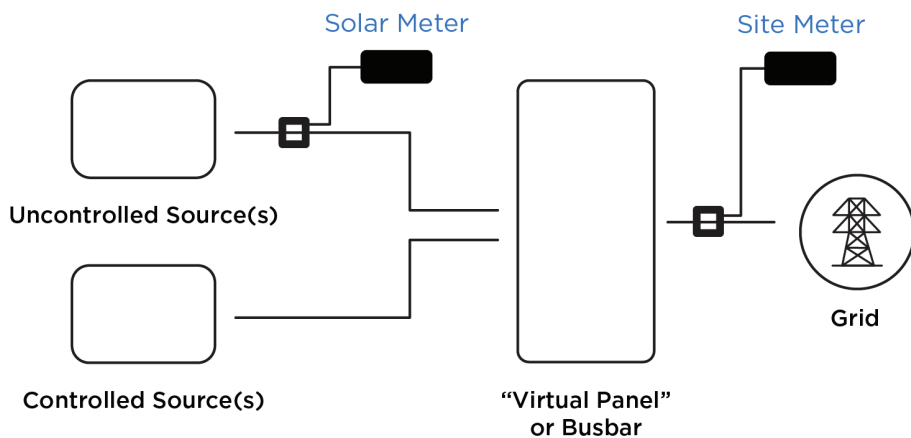

 **NOTE:** The default overcurrent protection rating for the PCS Panel Limit is 80 A. The Panel Limit can be set by Qualified Personnel to a maximum of 200 A.

 **WARNING:** The maximum PCS operating current setting shall not exceed the panel rating of any PCS controlled panel.



### 3.2 Example Single Line Diagrams for Common Installation Configurations

Figure 4. Powerwall+ and Backup Switch for Whole Home Backup

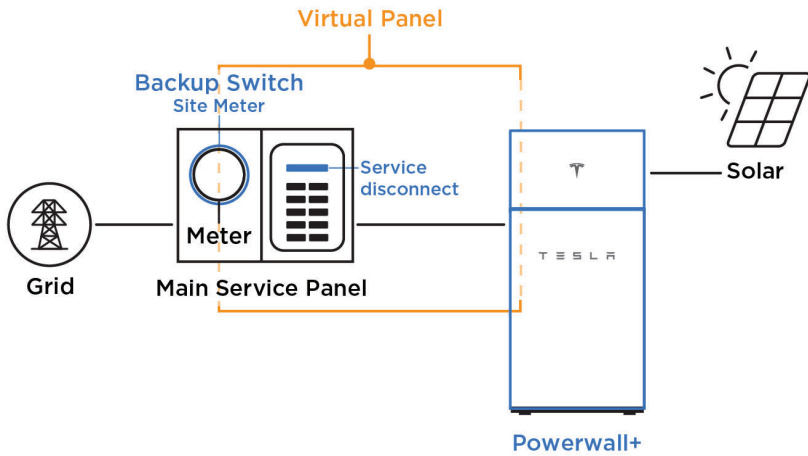

Figure 5. Powerwall+ and Gateway 2 for Whole Home Backup

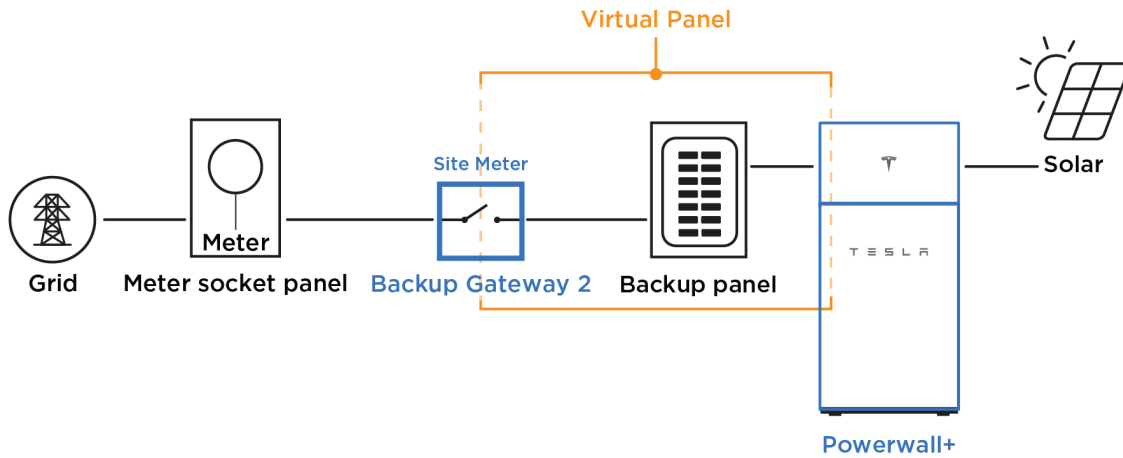

Figure 6. Powerwall 3 and Gateway 2 for Whole Home Backup

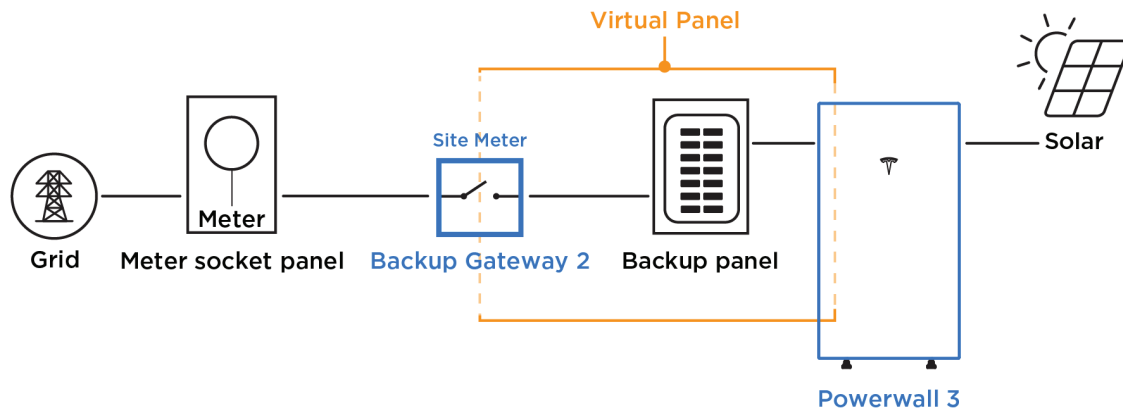
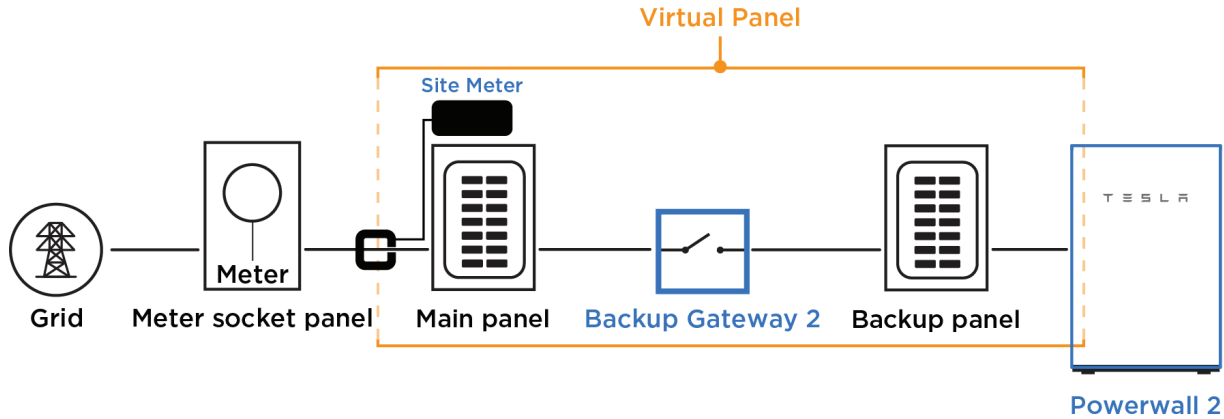



Figure 7. Powerwall 2 and Gateway 2 for Partial Home Backup



### 3.3 Application of the Panel Limits Feature

The Panel Limits feature is most functional when using Powerwall+ or Powerwall 3 since the solar and battery currents are “controllable.” If using Panel Limits with any standalone inverter (Tesla Solar Inverter or third-party), this solar current is not controllable. There is still benefit to using Panel Limits to limit the contribution of backfeed from the energy storage system (Powerwall 2, Powerwall+, or Powerwall 3)

Typical Setting: Amperage of main panel rating, or any panel on site that requires protection from backfeed.

**Example:**

- A system has a 200A main panel rating with a 200A main breaker.
- When following the 120% rule (NEC 2020 705.12(B)(3)(2)) the 200A main panel can have 240A of combined supply source breakers, which includes the 200A main and a 40A breaker for new generation.
- The system design calls for 2 Powerwall+ units, 1 Powerwall 2, and 1 40A standalone PV inverter.

**Solution:**

- Backfeed breakers land in a backup load center. Panel Limit Setting: 160A.
- The 40A from uncontrolled PV is acceptable by the 120% rule. Load centers will not see >160A from controllable sources.



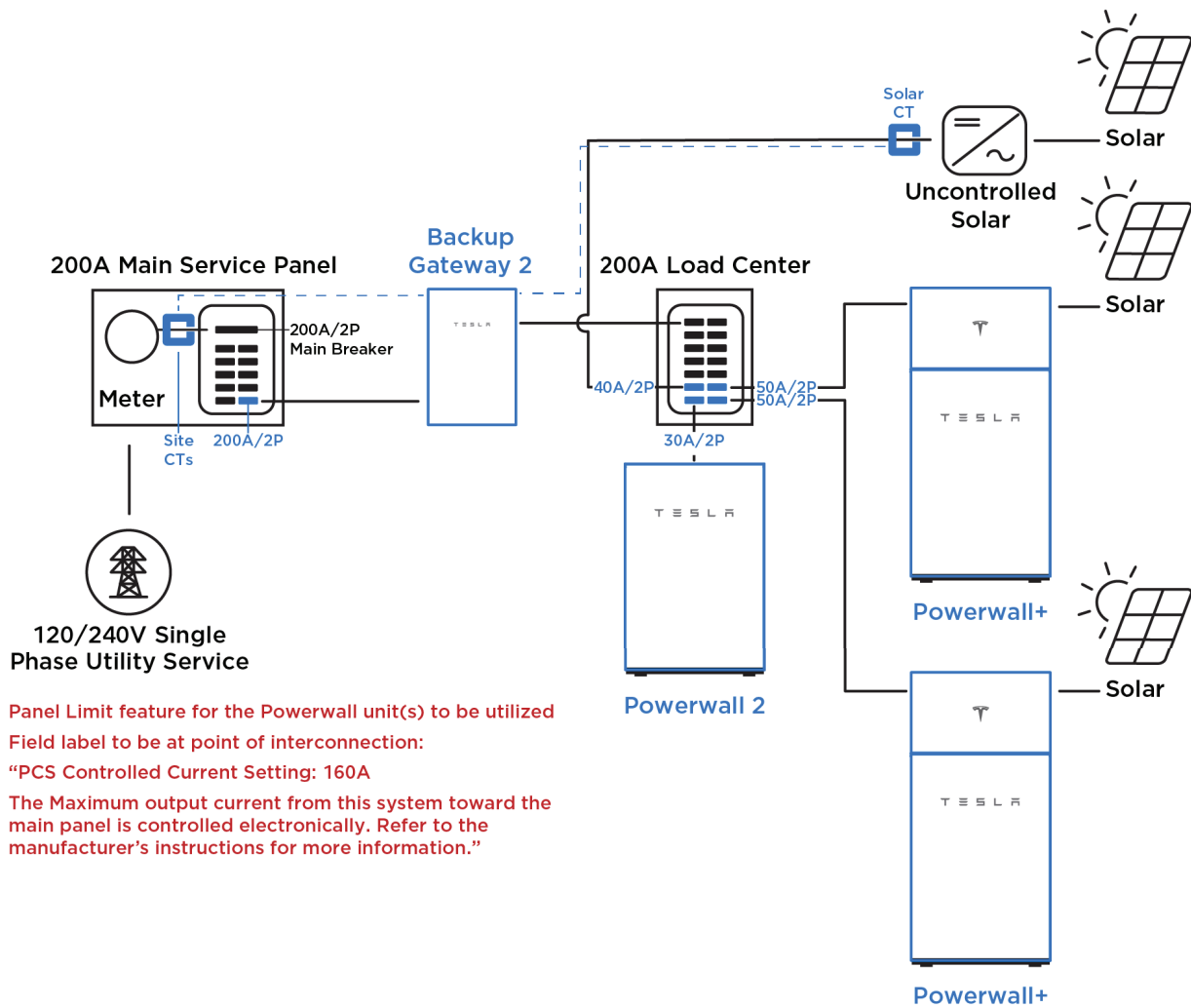

Panel Limit feature for the Powerwall unit(s) to be utilized  
 Field label to be at point of interconnection:  
 "PCS Controlled Current Setting: 160A  
 The Maximum output current from this system toward the  
 main panel is controlled electronically. Refer to the  
 manufacturer's instructions for more information."

**NOTE:** This feature impacts the maximum contribution of backfeed from controllable sources. It will not restrict the energy that can be drawn from the utility. The setting should not be used to undersize load centers or overcurrent protection; equipment should always be sized based on loads.

**NOTE:** No additional CTs are required for this, other than those already needed to capture the whole site and all solar.

### 3.4 Configuring Panel Limits

The Panel Limit can be configured by Qualified Personnel in the Tesla Pros app; to change the default limit of 80 A (between 10 and 200 A), select **Settings > Advanced Settings > PCS Settings**.

To disable the Panel Limit, delete the value in the *Continuous Current* field.



The image shows three sequential screenshots from a mobile application. The first screenshot, titled "Settings", shows a list of configuration options: "Grid Code" (IEEE1547-2018\_UL1741SB-CA-Rule21\_2023), "Import & Export Limits", "Solar Installation Type" (Solar Roof), and "Advanced Settings" (More settings for advanced installs). The "Advanced Settings" option is highlighted with a blue border. The second screenshot, titled "Advanced Settings", shows a list of sub-settings: "Operation Settings" (Set Backup Reserve and Mode), "PCS Settings" (Power Control System), "Low Voltage Relay Control" (Control external equipment), "Time Zone" (America/New\_York), "Special Programs", and "Factory Reset" (Reset device to factory settings). The "PCS Settings" option is highlighted with a blue border. The third screenshot, titled "PCS Settings", shows the "Panel Limit" section. It includes an information icon, a warning text: "Current output will be limited if the uncontrolled sources exceed the continuous current rating of the electrical system.", and a "Continuous Current" input field set to "80 A". Below the input field, a note states: "Suitable for a 100A rated panel. System will curtail if home load exceeds 19.2kW." A blue "Done" button is at the bottom of the screen.



## 4 Site Limit Feature

### 4.1 Feature Overview



**NOTE:** Maximum overcurrent protection rating for PCS Site Limits: 200 A.

Every system has a Site meter which monitors energy flow to and from the grid. For some systems there may be restrictions on the maximum power that can be sent in one direction or the other; there are a variety of reasons for these restrictions, as described below. The Site Limit feature allows Qualified Personnel to set Site Import and/or Export limits to ensure the system does not exceed the amount of power that can be imported or exported per site requirements. As described below, Site Import and Export limits can be set to restrict import / export by source (e.g. Powerwalls can only charge from Solar) or to limit import / export to a numerical value (e.g. can only export up to 10 kW).

The net site power measurement can be a virtual aggregated meter. For example, when both Gateway Meter X and Meter Y are both measuring Site, the combination of Meter X and Meter Y are considered the aggregated Site meter. Therefore, abide by all prior guidance on meters and CTs.

### 4.2 Site Import Permissions

*Site Import Permissions* can be set to configure the energy source that Powerwall can charge from (grid and solar or only solar). Site Import Permissions only apply to Powerwall systems with solar, as Powerwall systems without solar can only charge from the grid.

The default Site Import Permission for Powerwall systems with solar is “Charge from Grid Allowed,” which enables the customer to configure grid charging in their Tesla app (when charging from grid is allowed by the installer, the default setting in the customer app is to not charge from grid unless the customer enables it). The installer may select “Charge from Grid Disallowed” on the Import & Export Limits page in the Setup App which will prevent the customer from configuring grid charging in the Tesla app.



**NOTE:** To configure a system as “Export Only,” set the Site Import Permission to “Charge from Grid Disallowed.”



**NOTE:** Previous Investment Tax Credit (ITC) guidance required that Powerwall be configured to only charge from solar; customers who did not claim the ITC or who had met the 5-year requirement *could enable grid charging in the Tesla app*. For more information on ITC guidance based on system configuration and installation year, see the [Tesla Energy Incentives page](#).





### 4.3 Site Import Limits

There may be a limit on how much power the site is allowed to import (see *Application of the Site Import Limits Feature* below for examples). In this case a *Site Import Limit* can be set to comply with that power limit. The **Site Import Limit** is set on the *Import & Export Limits* page in the Setup App. Depending on the limit set, this may result in Powerwall charging slower or discharging to keep the Site below the limit.

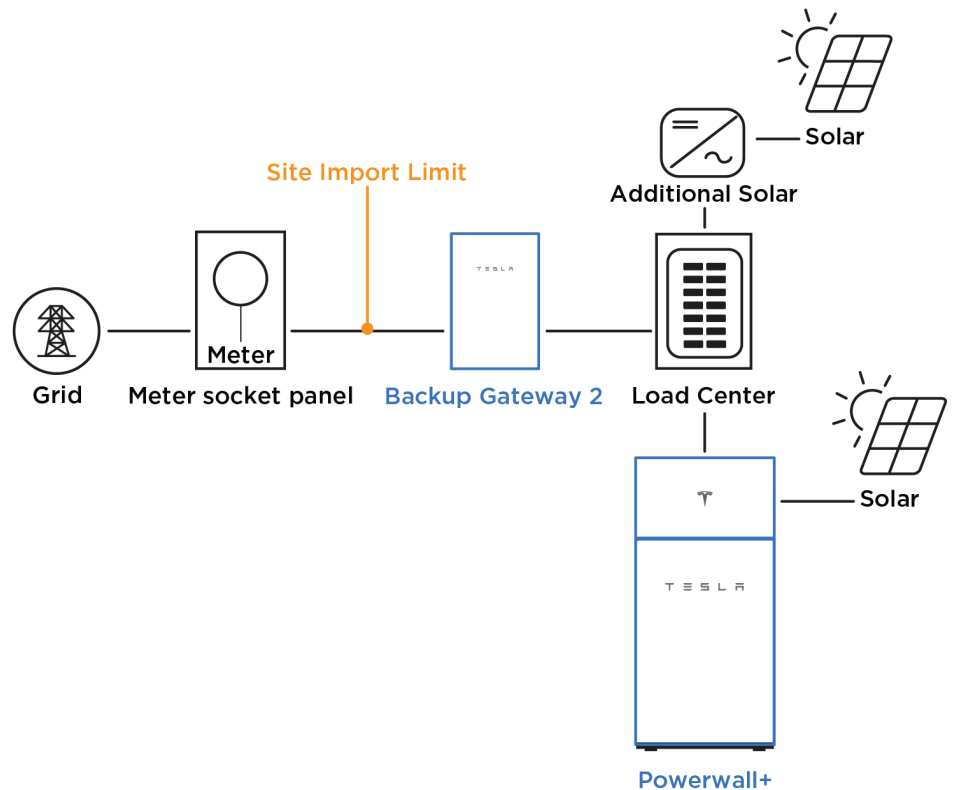

To stay at or below the Site Import Limit, first Powerwall reduces its charge rate. If necessary, it also discharges to the system. If the Site Import Limit is 10 kW and the system is importing 8 kW, Powerwall could charge at a max rate of 2 kW. In the same scenario, if the system is importing 12 kW then Powerwall will discharge at a rate of 2 kW to keep the overall import at 10 kW.

Notes:

- Available for Powerwall systems (with or without solar)
- Rarely used application in North American market
- Not the counterpart of Conductor Limits
- It may result in Powerwall charging at a slower rate, not charging at times of high load demand, or even discharging to keep the Site underneath the set limit



## 4.4 Application of the Site Import Limits Feature

### Example 1: Prevent Breaker Tripping

A system has six Powerwalls which charge from the grid at up to 5 kW each, for a total of 30 kW (125A). The system has a 100A (24 kW) main breaker. To prevent the system from tripping the breaker, the installer limits site import to 80% of the main breaker, or 80A. The Site Import Limit is set as 19,200 W.

### Example 2: Prevent Main Panel or Transformer Upgrade

Some jurisdictions require that Powerwall be calculated as a load. In a system that is already fully loaded, this may result in a main panel and service upgrade. In rare cases, a utility may require a transformer upgrade to accommodate the Powerwall.

A system has 10 Powerwalls which charge from the grid at up to 5 kW each, for a total of 50 kW. The system has a 10 kVA transformer (continuous power rating). To avoid a transformer upgrade, the Site Import Limit is set as 10,000 W.

## 4.5 Site Export Permissions

*Site Export Permissions* determine whether Powerwall (the battery) and/or Solar can export to the grid. Site Export Permissions are determined by the utility, the permit, and the interconnect agreement – follow the most restrictive of these three for any site.

The installer can select one of two modes of operation for the system:

1. **Default (Solar Only):** The battery is commanded to not export beyond the site meter. The export at the site meter will be limited to the amount measured by the solar meter. Both controlled and uncontrolled solar will export.
2. **Permanent Non Export:** The battery and solar are commanded to never export beyond the site meter. See [Appendix A: Powerwall+ and Powerwall 3 Permanent Non-Export on page 25](#) for more information.

 **NOTE:** Inadvertent export is possible at any given time.

 **NOTE:** Uncontrolled solar will export unless it is separately configured not to (must be configured in that solar system's configuration interface).

 **NOTE:** Tesla Powerwall systems are certified to UL 1741 PCS for the energy storage system (ESS) operating modes of "Import Only" and "Export Only" when Import Permissions are configured accordingly. "Import Only" systems / interconnections prohibit batteries from exporting to the grid during normal operation. For a Tesla Powerwall system, this can be configured by setting the Export Permission to "Solar-Only" or "Non-Export," thus preventing the Powerwall from exporting battery power to the grid.

 **NOTE:** To achieve UL 1741 PCS Import Only behavior, either PV Only Export or NO SITE EXPORT must be selected. When the selected Grid Code applies to a region that requires UL 1741 PCS, such as California UL 1741 SA, the default setting is PV Only Export. In Setup App it is possible to further restrict the system to NO SITE EXPORT; however, once set, it is not possible to change back to PV Only Export. It is not possible for the installer to configure the system to allow BATTERY EXPORT.



**NOTE:** Only Tesla is able to configure a system to allow battery Export, for example when a system is part of a Virtual Power Plant that permits battery export during particular events. The option to join the Virtual Power Plant is automatically made available to the customer in the Tesla app and cannot be enabled by the installer.



## 4.6 Site Export Limits

For systems that can export to the grid, there may be a limit on how much power the site is allowed to export. In this case a *Site Export Limit* can be set to comply with that power limit. The **Site Export Limit** is set on the *Import & Export Limits* page in the Setup App.

The screenshot shows the 'Import & Export Limits' configuration screen. It has a back arrow in the top left. The title is 'Import & Export Limits'. Under 'Import Limits', 'Site Import Limit' is set to 'No Limit' with a 'W' icon, and 'Site Import Permissions' is set to 'Charge From Grid Allowed'. The 'Export Limits' section is highlighted with a blue border. It shows 'Site Export Limit' set to 'No Limit' with a 'W' icon, and 'Export Permissions' set to 'Select' with a dropdown arrow. A blue 'DONE' button is at the bottom.

To stay at or below the Site Export Limit, Powerwall first reduces discharge, then charges, then solar is curtailed. Below are a few examples for a system with no loads and a 10kW Site Export Limit:

- If solar production is at 8 kW, Powerwall can discharge at a rate of up to 2 kW to keep the overall export within 10kW
- If solar production is at 13 kW, Powerwall will charge at a rate of at least 3 kW to keep the overall export within 10 kW.
- If available solar production is 18 kW, Powerwall will charge at a rate of 5 kW (its maximum), then solar will be curtailed to 15 kW to keep the overall export within 10 kW.





## 4.7 Application of Site Export Limits

### Example 1: Utility Interconnect Requirement

The utility allows for up to 10 kW of solar export based on permit type. Rather than install only 10 kW of solar which may result in being unable to power system loads, a Site Export Limit of 10 kW allows for a larger system that adequately powers loads without violating the limit.

For example, if 15 kW of solar are installed, the Site Export Limit ensures that no more than 10 kW are exported at any time.

### Example 2: Incentive Limit

A system is incentivized for exporting up to 10 kW of solar. If there is a penalty for exporting more than 10 kW, the Site Export limit can be set to 10 kW. In this instance, if 12 kW of uncontrolled solar is being produced, Powerwall will charge at a rate of 2 kW to prevent the Site Export limit from being exceeded. Any controlled solar (produced by Powerwall+) would be curtailed.



## 5 Conductor Limit Feature

### 5.1 Feature Overview

The system can be configured to curtail power from all Powerwalls to limit the total current on a conductor (for example to limit backfeeding a panel). In doing so, the Conductor Limit is equivalent to the "power-source(s) output circuit current" outlined in the requirements of Article 705.12(B) of the NEC / CEC.

**NOTE:** Tesla recommends using the Panel Limit feature in most cases for jurisdictions using the 2023 NEC for simplified 705.13 backfeed compliance in accordance with 750.30.

**NOTE:** Conductor CTs must be installed on conductors that are between the grid connection and the Powerwalls or at a location where Powerwalls have control over current.

To configure a Conductor Limit, two current transformers (CTs) are installed to measure current at the controlled conductor location. Output from these CTs is measured and the data is fed to the Powerwall system. The system then coordinates Powerwall output current amperage to not exceed the current limit in real time.

Figure 8. Controlled Conductors where Backup Gateway Meter X CTs are Configured as Conductor CTs

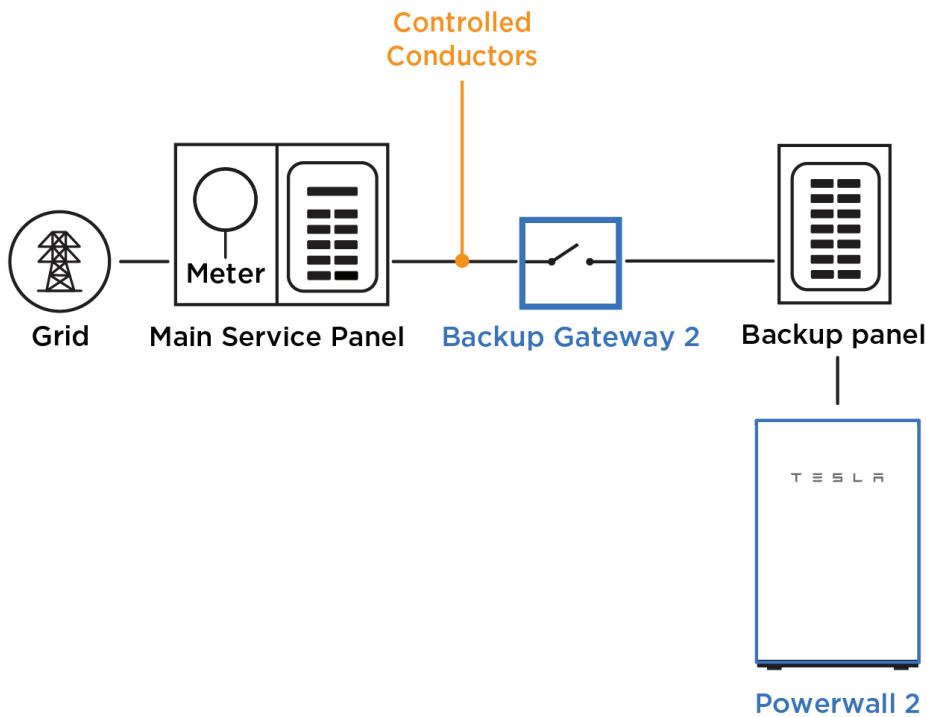

**NOTE:** This feature only limits the output contribution from all controlled sources. It does not limit output contribution from uncontrolled sources.

**NOTE:** This should not be used to replace overcurrent protection.

**WARNING:** The maximum PCS operating current setting shall not exceed the conductor ampacity of any PCS controlled conductor.



 **NOTE:** Maximum overcurrent protection rating for PCS controlled conductor: 200 A.

## 5.2 Application of the Conductor Limits Feature

Conductor Limits can be used to reduce backfeed contributed by Powerwall to more easily meet backfeed compliance on upstream load centers. This application reduces the frequency of main breaker derates and main panel upgrades.

The typical use case for Conductor Limits is to set an amperage allowable backfeed current that is compliant with the upstream load center.

### Example 1: Greater than 200A of Sources in the Generation Panel

Over 200A of Powerwalls and PV are being installed in an appropriately sized generation panel (ex: 225A or 400A). This generation panel must have a 200A main breaker to protect the Backup Gateway (200A rating). To ensure the generation panel main breaker does not trip, a Conductor Limit of 200A is set.

In the example below, two 200A Neurio CTs are installed with a Neurio meter and configured as Conductor CTs.

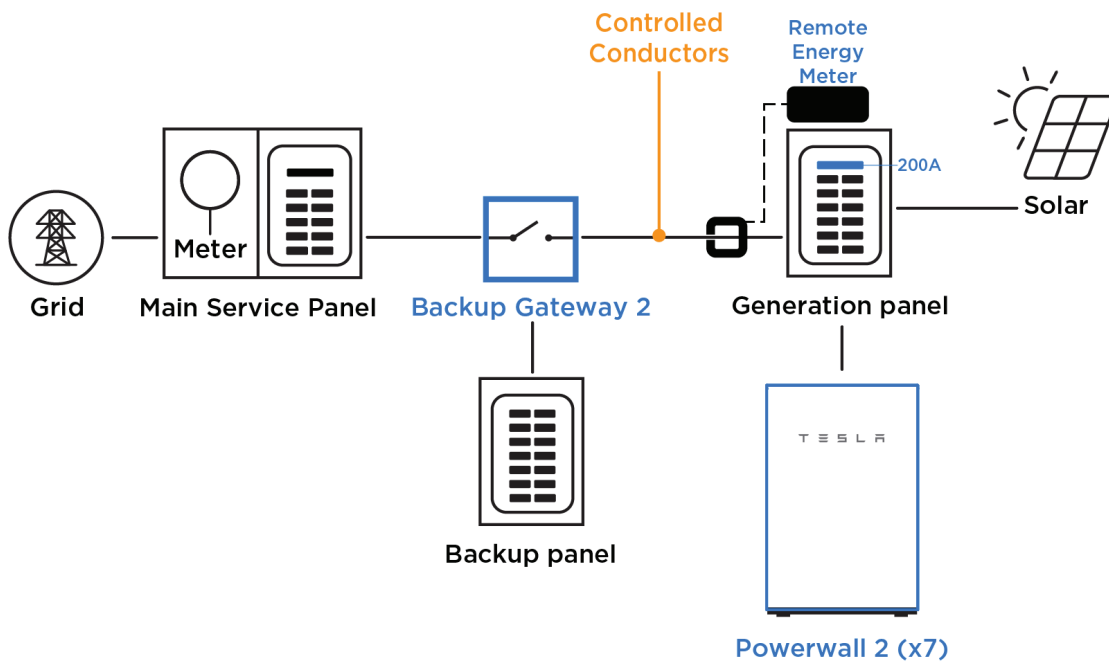



**Example 2: Three Powerwalls in System with 200A Main Panel / 200A Main Breaker**

A system has a 200A main panel rating and a 200A main breaker. Following the 120% rule, only 32A of backfeed would be allowed (40A breaker). The most advantageous solution would be to set a Panel Limit of 100A.

If setting a Panel Limit is not an option, install the Backup Gateway on a breaker sized for the backup panel (in this example a 100A breaker is used because the backup panel is 100A rated) and set a Conductor Limit of 32A (40A of equivalent overcurrent protection \* 0.8 = 32A continuous). In this scenario, the Meter X CTs in the Backup Gateway are configured as Conductor CTs.

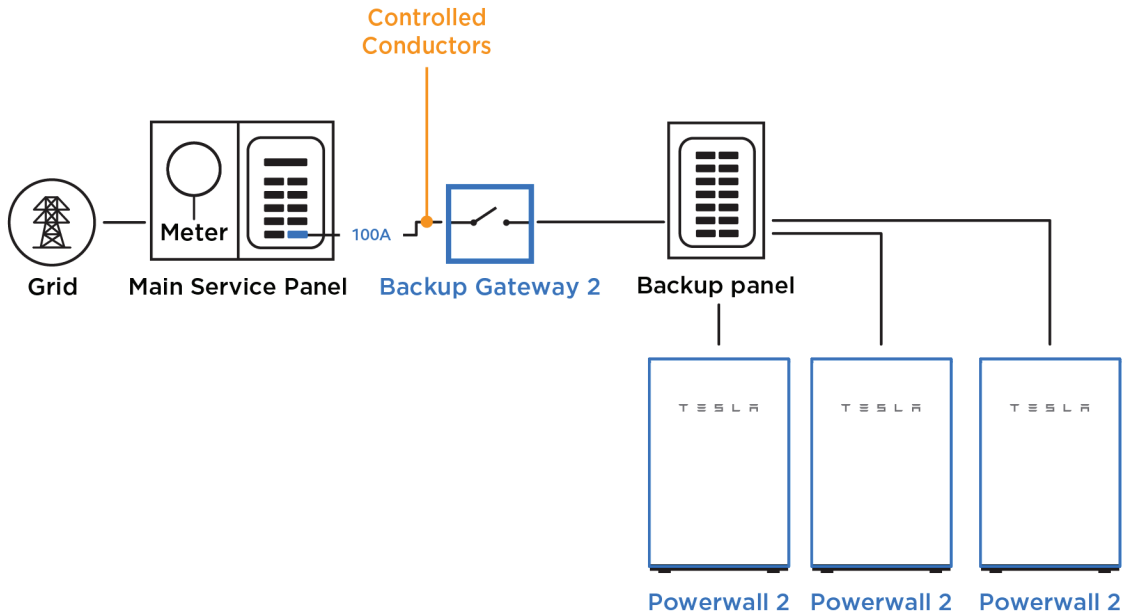





**Example 3: Three Powerwalls in System with 200A Main Panel / 200A Main Breaker**

In the instance that a Conductor Limit is not an option for the system as discussed in Example 1, the least advantageous solution is to install the three Powerwalls in a generation panel fed by a 40A breaker. To prevent the Powerwalls from exceeding that breaker’s capability, install two Conductor CTs and set the Conductor Limit to 32A (40A of equivalent overcurrent protection \* 0.8 = 32A continuous).

**NOTE:** A 40A breaker was selected based on this backup panel being a 200A panel fed by a 200A main; with a conservative interpretation of the 120% rule and without permitted use of software limits, a 40A breaker can be used.

**NOTE:** During a grid outage, the power produced by the Powerwalls is not limited to Conductor Limits; therefore, the 40A breaker may trip if loads in the upstream backup panel exceed 40A.

In the example below, two CTs are connected to Meter Y in the Backup Gateway and configured as Conductor CTs.

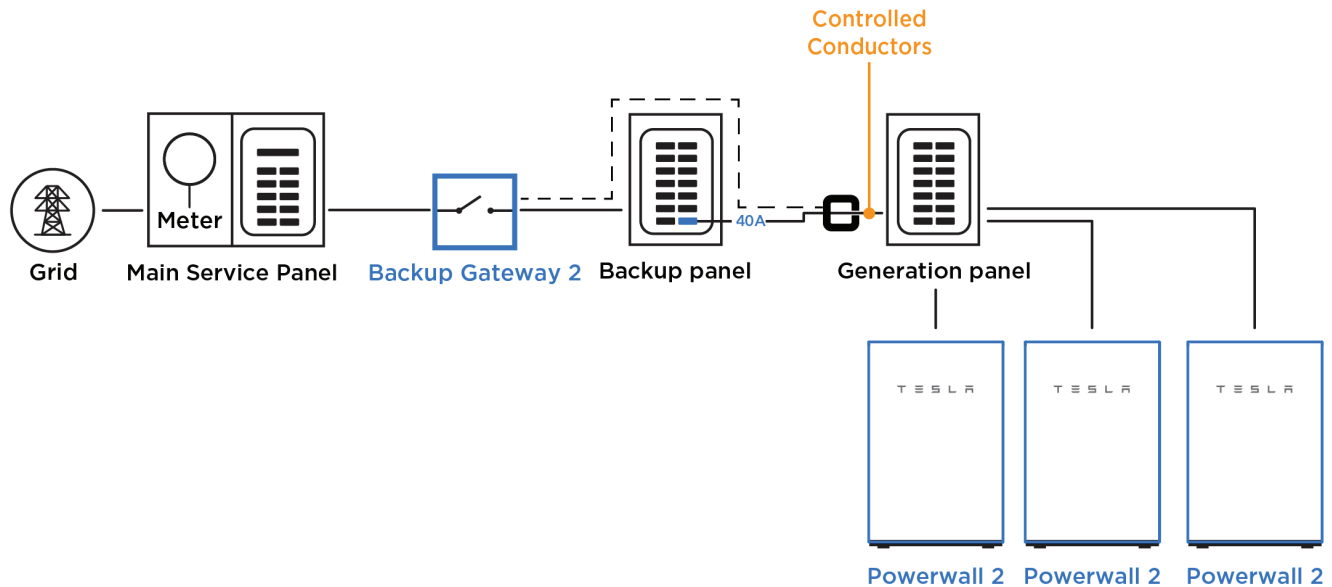



### 5.3 Installing and Configuring Conductor CTs

Install Conductor CTs on conductors that are between the grid connection and the Powerwalls, or at a location where Powerwalls have control over current. Ensure the Conductor CTs are oriented the same way as Site CTs (the label faces toward the grid).

Conductor Limits are configured using the Commissioning Wizard:

1. Scan the QR code on the product serial number label to connect to the TEG Wi-Fi network.
2. Open a browser and navigate to <http://TEG-YYY> where YYY are the last 3 digits of the Backup Gateway serial number.
3. Log in to the Commissioning Wizard using the email address of the installer who is carrying out the work and the password on the serial number label. See the [Powerwall Commissioning Guide](#) for additional instructions on connecting to the TEG Wi-Fi network and entering the Commissioning Wizard.
4. On the *Current Transformers* page, configure the CT(s) as **Conductor**.
5. On the *Operation Settings* page, enter the amperage for the Conductor Limit in the **Conductor Export Limit** field.



## 6 Appendix A: Powerwall+ and Powerwall 3 Permanent Non-Export

### 6.1 Overview

Where required by utilities, Powerwall+ and Powerwall 3 can be placed in a permanent non-export mode. This means that in the following scenarios, Powerwall+/Powerwall 3 will curtail solar to prevent power from being exported back to the grid:

- The battery is fully charged and more solar is being produced than the system is consuming
- Solar is being produced at a higher rate than the battery can charge at, e.g. 7.6kW of solar on a 5kW battery

This feature is available beginning with Powerwall software version 22.18. One important note is that, in a Powerwall+ or Powerwall 3 system, Powerwall+/Powerwall 3 is the only solar inverter capable of curtailing solar as described above. As such, Powerwall+/Powerwall 3 is referred to as “controlled solar.” Third party solar inverters cannot be controlled by the Powerwall system Site Controller in the same manner and are referred to as “uncontrolled solar.”

This document describes three possible permanent non-export configurations: one with exclusively controlled solar, one with uncontrolled (third party) solar that is allowed to export solar to the grid, and one with uncontrolled (third party) solar that is not allowed to export solar to the grid.

### 6.2 Install Metering for a Permanent Non-Export System

Metering in a permanent non-export system is essentially the same as in any Powerwall system:

- Site metering must capture all loads and generation, including non-backup loads
- Solar metering must capture all solar generation, including third party solar inverters

In addition to the Powerwall system metering, any third party solar inverter also requires its own Site meter if it is configured for non-export. Third party Site metering should follow the third party inverter’s installation instructions and should not be modified by the Powerwall system.

The following examples illustrate some common metering configurations for a permanent non-export system.



Example 1: Powerwall 3 Permanent Non-Export System with Only Controlled Solar

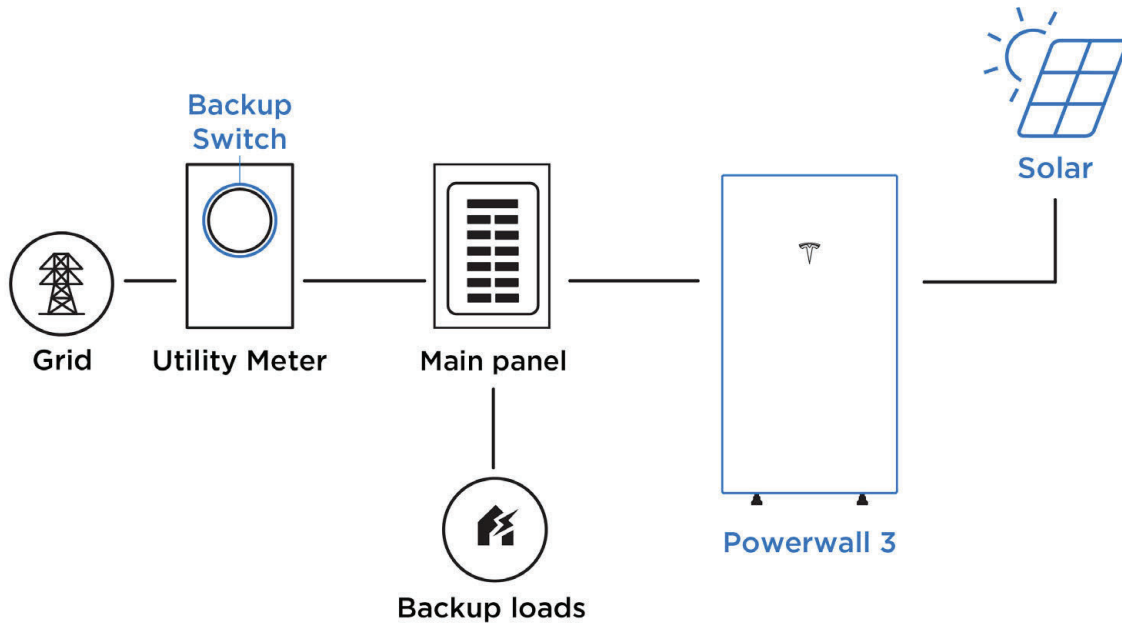

Energy to be Metered	Meter	CT(s)	Meter Configuration
Site loads	Backup Switch	Backup Switch (not shown in diagram)	Preconfigured as Meter Z: Site
Powerwall 3 Solar Generation	Powerwall 3 integrated energy meter	N/A	N/A
Powerwall+ Solar generation	Factory-installed Neurio meter	Factory-installed Neurio 200 A CT	Meter paired with Powerwall+ and CT field-configured as Neurio Meter: SolarCTx2





Example 2: Permanent Non-Export System with Uncontrolled Solar

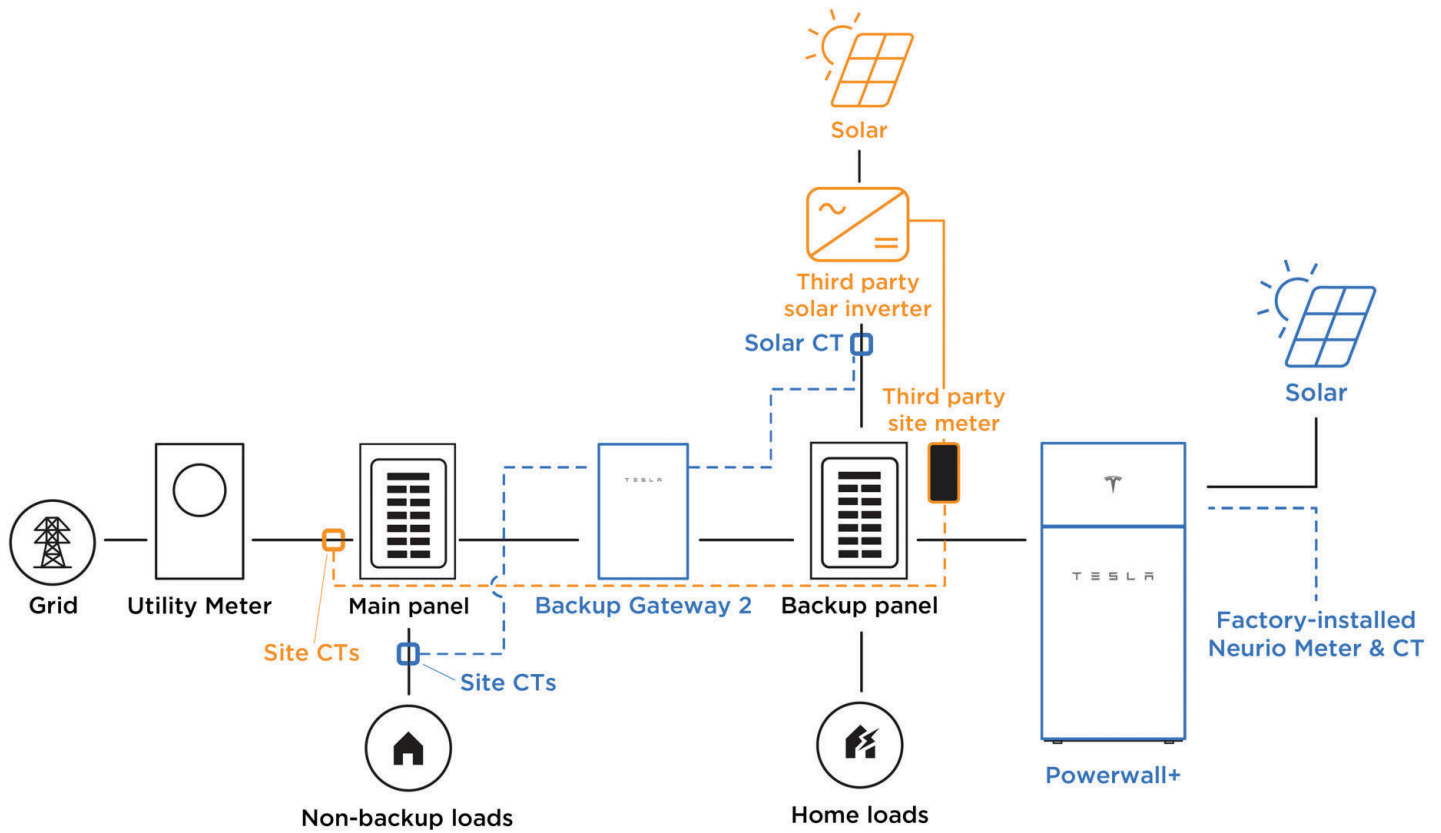

Energy to be Metered	Meter	CT(s)	Meter Configuration
Site backup loads	Backup Gateway Meter X	Backup Gateway Meter X (not shown in diagram)	Preconfigured as Meter X: Site
Site non-backup loads	Backup Gateway Meter Y	Field-installed Tesla 100 A CTs	Field-configured as Meter Y: Site
Powerwall+ Solar generation	Factory-installed Neuroio meter	Factory-installed Neuroio 200 A CT	Meter paired with Powerwall+ and CT field-configured as Neuroio Meter: SolarCTx2
Third party Solar generation	Backup Gateway Meter Y	Field-installed Tesla 100 A CT	Field-configured as Meter Y: SolarCTx2
Third party Site loads	Third party Site meter	Third party Site CTs	Configured by inverter installer to measure Site



### 6.3 Configure a System for Permanent Non-Export Mode

1. When commissioning the system, set *Export Permissions* to **Permanent Non Export** on the *Operation Settings* page.
2. If the system has standalone solar, uncontrolled by the Powerwall system, determine whether the solar inverter is allowed to export and if that solar inverter is configured with its own controls to prevent export.
  - a. If it is allowed to export solar, toggle *Solar export limitation* to **No**.
  - b. If it is not allowed to export solar, and is configured with its own non-export controls, toggle *Solar export limitation* to **Yes**.

The screenshot shows the 'Import & Export Limits' configuration screen. It includes sections for 'Site Import Permissions' (Charge From Grid Allowed), 'Export Limits' (Site Export Limit: No Limit), 'Export Permissions' (Permanent Non Export), and 'Solar Export Limitation' (Is this Powerwall installed alongside a zero-export solar inverter? with 'No' selected). A 'DONE' button is at the bottom.



**NOTE:** This provides the Powerwall system with the knowledge that it needs to regulate a small amount of import power to prevent the standalone non-export solar inverter from curtailing. This ensures the best overall system performance for these systems that have two devices both responding to site power measurements.

3. Take screenshot of this page and the system *Summary* page after completing commissioning. These will be required as part of the interconnection submission.



## 7 Revision History

Revision	Date	Description
1.0	2023-06-29	Initial release
1.1	2023-11-01	<ul style="list-style-type: none"><li>• Updated <a href="#">Panel Limit Feature on page 9</a> to reflect changes to default Panel Limit and updated method of configuring a Panel Limit</li><li>• Updated to include Powerwall 3</li><li>• Added <i>Qualified Personnel</i> to <a href="#">Glossary on page 3</a></li></ul>