

PHOTOVOLTAIC ROOF MOUNT SYSTEM

CODE AND STANDARDS

THE INSTALLATION OF SOLAR ARRAYS AND PHOTOVOLTAIC POWER SYSTEMS SHALL COMPLY WITH THE FOLLOWING CODES:

- 2020 NATIONAL ELECTRICAL CODE
- 2018 NORTH CAROLINA RESIDENTIAL CODE
- 2018 NORTH CAROLINA BUILDING CODE
- ALL OTHER ORDINANCE ADOPTED BY THE LOCAL GOVERNING AGENCIES

SITE NOTES / OSHA REGULATION

1. A LADDER SHALL BE IN PLACE FOR INSPECTION IN COMPLIANCE WITH OSHA REGULATIONS.
2. THE SOLAR PV INSTALLATION SHALL NOT OBSTRUCT ANY PLUMBING, MECHANICAL, OR BUILDING ROOF VENTS.
3. ROOFTOP MOUNTED PHOTOVOLTAIC PANELS AND MODULES SHALL BE TESTED, LISTED AND IDENTIFIED BY RECOGNIZED ELECTRICAL TESTING LABORATORY.
4. MODULES AND SUPPORT STRUCTURES SHALL BE GROUNDED
5. SOLAR INVERTER SHALL BE LISTED TO UL1741
6. ALL CONDUCTORS SHALL BE COPPER AND SHOULD BE 75 AND 90 DEG RATED
7. REMOVAL OF AN INTERACTIVE INVERTER OR OTHER EQUIPMENT SHALL NOT DISCONNECT THE BONDING CONNECTION BETWEEN THE GROUNDING ELECTRODE CONDUCTOR, THE PHOTOVOLTAIC SOURCE AND OUTPUT CIRCUIT GROUNDED CONDUCTORS.
8. LIVE PARTS OF PV SOURCE CIRCUITS AND PV OUTPUT CIRCUITS OVER 150V TO GROUND SHALL NOT BE ACCESSIBLE TO OTHER THAN QUALIFIED PERSONS WHILE ENERGIZED.
9. ALL PV MODULES AND ASSOCIATED EQUIPMENT AND WIRING SHALL BE PROTECTED FROM PHYSICAL DAMAGE.

SOLAR CONTRACTOR

1. MODULE CERTIFICATIONS INCLUDE UL1703, IEC61646, IEC61370.
2. IF APPLICABLE, MODULE GROUNDING LUGS MUST BE INSTALLED AT THE MARKED GROUNDING LUG HOLES PER THE MANUFACTURERS INSTALLATION REQUIREMENTS.
3. AS INDICATED BY DESIGN, OTHER NRTL LISTED MODULE GROUNDING DEVICES MAY BE USED IN PLACE OF STANDARD GROUNDING LUGS AS SHOWN IN MANUFACTURER DOCUMENTATION AND APPROVED BY THE AHJ.
4. ALL MICROINVERTERS, PHOTOVOLTAIC MODULES, AC COMBINERS, DC-AC CONVERTERS AND SOURCE CIRCUIT COMBINERS INTENDED FOR USE IN A PHOTOVOLTAIC POWER SYSTEM WILL BE IDENTIFIED AND LISTED FOR THE APPLICATION PER NEC690.4(B).
5. ALL SIGNAGE TO BE INSTALLED IN ACCORDANCE WITH LOCAL BUILDING CODE.
6. TERMINALS AND LUGS WILL BE TIGHTENED TO MANUFACTURER TORQUE SPECIFICATIONS (WHEN PROVIDED) IN ACCORDANCE WITH NEC CODE 110.14(D) ON ALL ELECTRICAL CONNECTIONS.
7. MAX DC VOLTAGE CALCULATED USING MANUFACTURER PROVIDED TEMP COEFFICIENT FOR VOC UNLESS NOT AVAILABLE.

DESIGN CRITERIA
WIND SPEED: 115 MPH
GROUND SNOW LOAD: 15 PSF
WIND EXPOSURE FACTOR: B

UTILITY COMPANY:
DUKE ENERGY
PERMIT ISSUER (AHJ):
HARNETT COUNTY

SCOPE OF WORK
 INSTALLATION OF UTILITY INTERACTIVE PHOTOVOLTAIC SOLAR SYSTEM.

SR.#	PROJECT INFORMATION	
1	PV MODULES	36 x Q.TRON BLK M-G2+ 425W
2	INVERTER + BATTERY	02 X POWERWALL3
3	ROOF TYPE	ASPHALT SHINGLES
4	RACKING	PSR-B84 RAILS (BLACK)
5	MOUNTING TYPE	COMP MOUNT FLASHING (BLACK)
6	DC SIZE	15.3 KW
7	AC SIZE	20.0 KVA
SR.#	PROJECT INFORMATION	
1	PV1	DRAWING INDEX
2	PV2	SITE LAYOUT
3	PV3	STRING MAPPING
4	PV4	ELECTRICAL ONE LINE DIAGRAM
5	PV5	DETAILED ELECTRICAL WIRING SCHEMATIC
6	PV6	PV LABELS
7	PV7	BILL OF MATERIALS
8	PV8	ATTACHMENT DETAILS

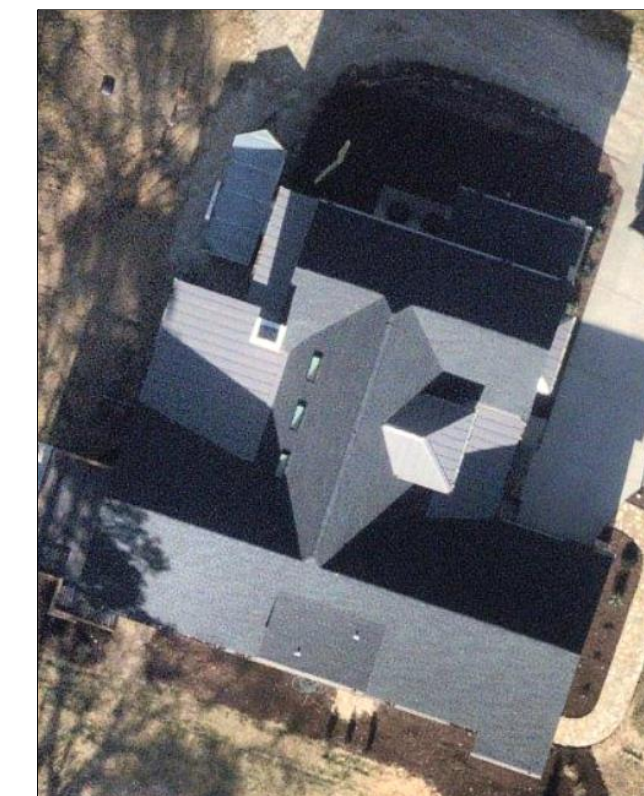

VICINITY MAP

TOP VIEW OF THE BUILDING



5112 Departure Drive,
 Raleigh NC 27616
 O: 919.948.6474
 E: info@8msolar.com

Customer Information:

George B Womble
 109 Overlook Court
 Angier NC 27501

Customer Signature:

Sheet Name:

Drawing Index

JOB NUMBER:

24-336-GW

Date:

07/02/2024

Revision:

B

Sheet Size:

ANSI C
 17" X 22"

Sheet Number:

PV1



ROOF DESCRIPTION			
ROOF	PITCH	AZIMUTH	NO. OF MODULES
A	52°	199°	36
Vent		<ul style="list-style-type: none"> Roof A has no vents. No vents will be covered by PV modules during the installation. 	

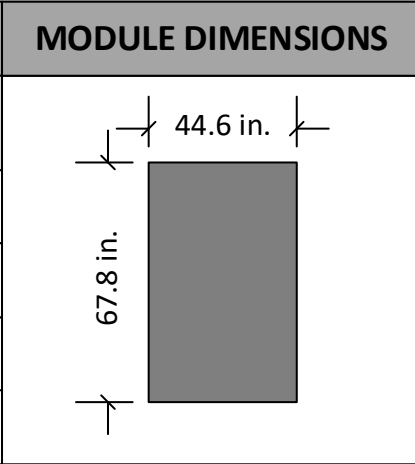

PV System Dead Load (Panel + Racking weight) / PV System Area (No. of panels x Weight of panel (lbs.) + Length of racking (ft.) x 1.15 lb.ft.) / (No. of panels x Height x Width) = Total psf				
ROOF	A			
DEAD LOAD (PSF)	2.68			

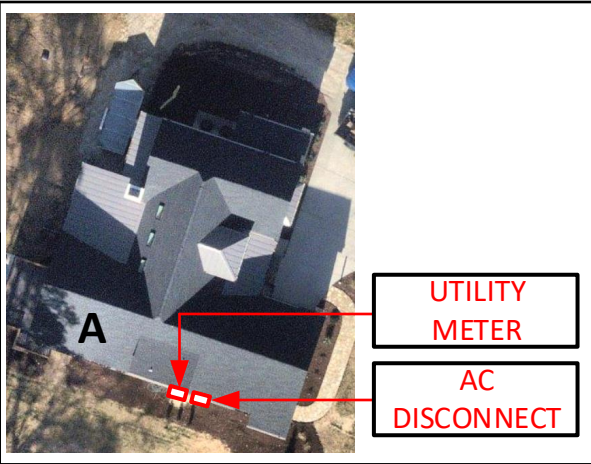

SYSTEM DETAILS

NUMBER OF PANELS : 36
 PANELS MODEL : Q.TRON BLK M-G2+ 425W
 DC SIZE : 15.3 KW
 AC SIZE : 20.0 KVA



5112 Departure Drive,
 Raleigh NC 27616
 O: 919.948.6474
 E: info@8msolar.com

Customer Information:

George B Womble
 109 Overlook Court
 Angier NC 27501

Customer Signature:

Sheet Name:

Site Layout

JOB NUMBER:

24-336-GW

Date:

07/02/2024

Revision:

B

Sheet Size:

ANSI C
 17" X 22"

Sheet Number:

PV2

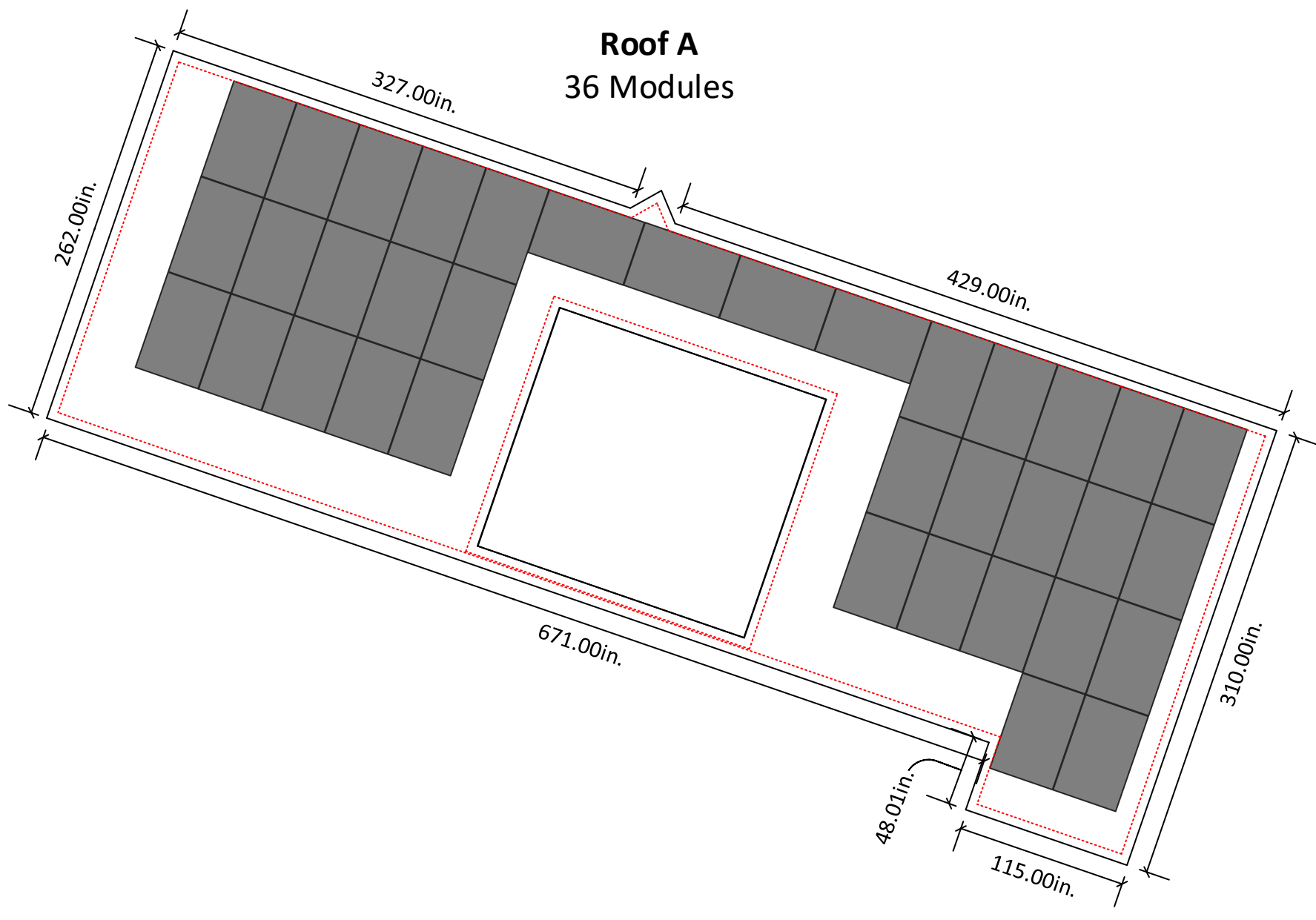

6in setback from sides of the roof

SITE LAYOUT
 SCALE: 1/8" - 1'

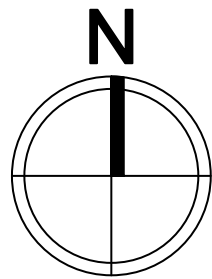

ROOF DESCRIPTION			
ROOF	PITCH	AZIMUTH	NO. OF MODULES
A	52°	199°	36

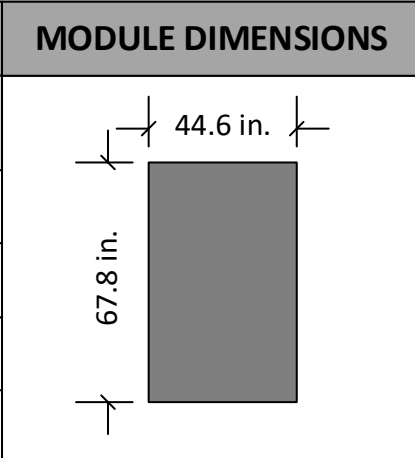

STRING LAYOUT					
TESLA POWERWALL3 (A)			TESLA POWERWALL3 (B)		
Strings #	No. of Modules	Color	Strings #	No. of Modules	Color
String 1	09	Blue	String 3	09	Green
String 2	09	Orange	String 4	09	Purple

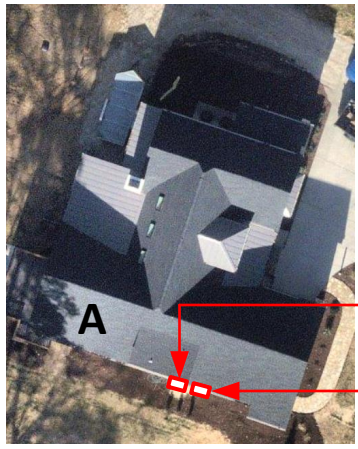

UTILITY METER
AC DISCONNECT



5112 Departure Drive,
Raleigh NC 27616
O: 919.948.6474
E: info@8msolar.com

SYSTEM DETAILS

NUMBER OF PANELS : 36
PANELS MODEL : Q.TRON BLK M-G2+ 425W
DC SIZE : 15.3 KW
AC SIZE : 20.0 KVA

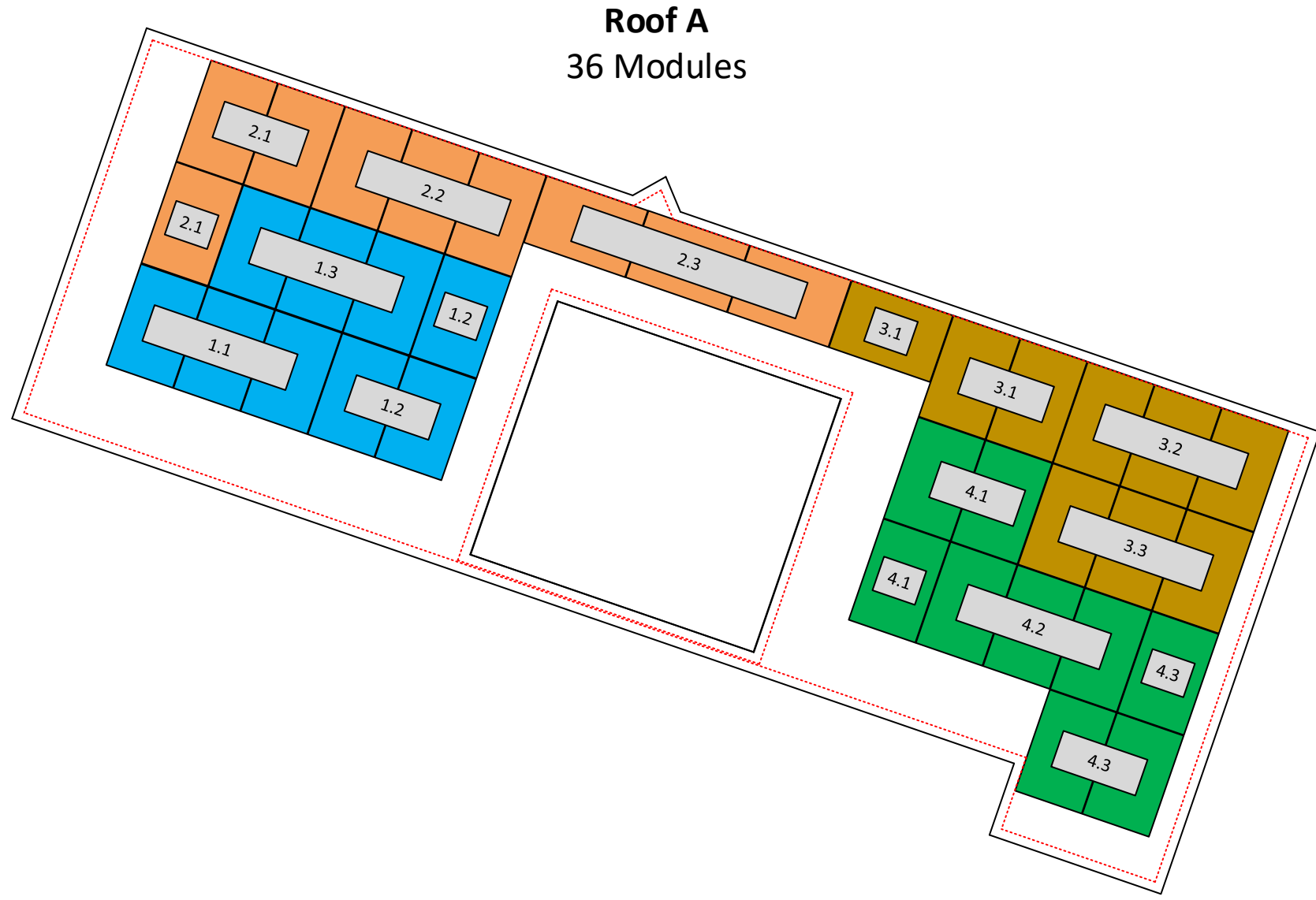

Tesla MCI (Mid Circuit Interrupter)

Customer Information:

George B Womble
109 Overlook Court
Angier NC 27501

Customer Signature:

Sheet Name:

String Mapping

JOB NUMBER:

24-336-GW

Date:

07/02/2024

Revision:

B

Sheet Size:

ANSI C
17" X 22"

Sheet Number:

PV3

6in setback from sides of the roof

STRING MAPPING
SCALE: 1/8" - 1'

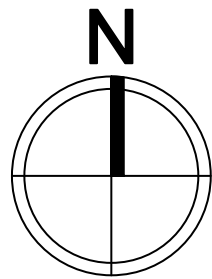

STRING CALCULATION

String #	No of Modules	Estimated Power	I _{max}	I _{mp}	V _{oc}	V _{mpp}
1,2,3,4	09	3,825 W	20.24 Adc	12.98 Adc	351.27Vdc	550 Vdc

NEC Code (2020) and UL Standard References

Rapid Shut Down	NEC 690.12 (A-D), UL1741	Grounding	NEC Article 250.30(A)
Disconnecting Means	NEC 690.13	Conduit Fill	NEC Table C.9, 310.15(B)(3)(a)
Feeder Sizing	NEC Table 310, 15(B)(16, 17)	Interconnection	NEC 705.12
Over current Protection	NEC 690.9		



5112 Departure Drive,
Raleigh NC 27616
O: 919.948.6474
E: info@8msolar.com

36 X Q.TRON BLK M-G2+ 425W
425W
TESLA MCI-2 (Mid Circuit Interrupter)
RAPID SHUTDOWN EQUIPPED

Tesla Powerwall3 – A (Leader)
1707000-00-J

Tesla Powerwall3 – B (Follower)
1707000-00-J

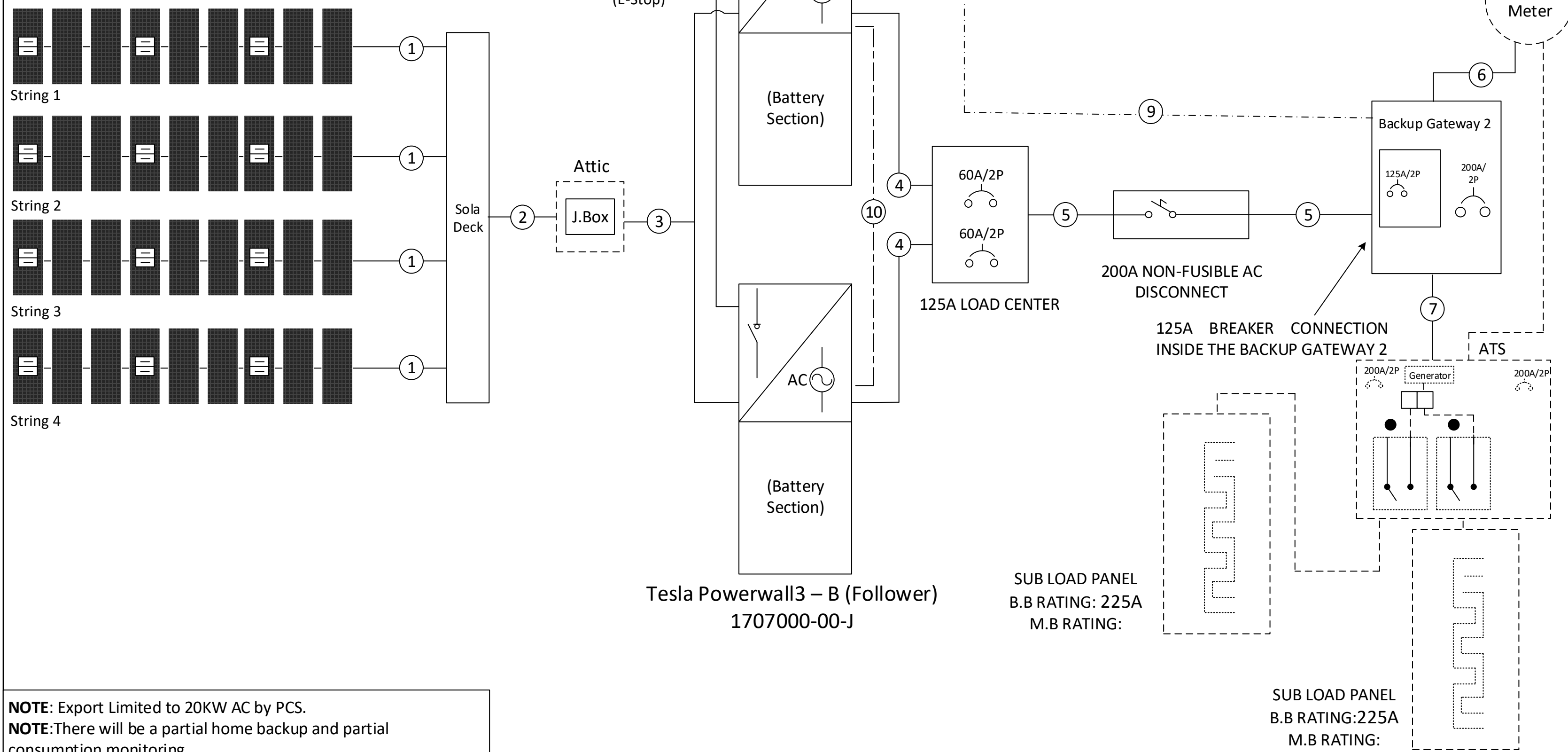

Service Side Work: Power Drop Required

Customer Information:

George B Womble
109 Overlook Court
Angier NC 27501

Customer Signature:

Sheet Name:

Electrical One Line Diagram

JOB NUMBER:

24-336-GW

Date:

07/02/2024

Revision:

B

Sheet Size:

ANSI C
17" X 22"

Sheet Number:

PV4

NOTE: Export Limited to 20KW AC by PCS.
NOTE: There will be a partial home backup and partial consumption monitoring.

- System Size: 15,300 W DC
- Battery Total Energy: 13.5 KWh
- (36) Q.TRON BLK M-G2+ 425W
- (12) 1879359-00-X: Tesla MCI-2
- (02) Tesla Powerwall3 (1707000-00-J)
- Inverter Output: 48A max @ 240 VAC (each)
- 20.0 kVA AC output max

- Grounding will be done via Pegasus grounding lugs and mid-clamps to ensure the rail and panels are continuously grounded.
- Rapid Shutdown is included in the Mid Circuit Interrupter, refer to Mid Circuit Interrupter and Inverter attached datasheets.
- The load center/disconnect will be visible, lockable, accessible to utility linesmen, and properly labeled per NEC requirements. It will be located on the exterior wall next to the utility meter.
- Prepare cable in usual manner.
- Stretch tape and apply half-lapped to form void-free joint. Degree of stretch is not critical and may vary in different sections of joint to accomplish void-free application.
- Protect the joint with two half-lapped layers of any scotch vinyl plastic electrical tape.

Sr.No	#Wire	Conduit Size	Ground Wire	Amperage
1	2 x #10 PV		#10 Bare Cu	20.24
2	4 x #10 MC Cable			20.24
3	8 x #10 THHN Cu	3/4" EMT	#10 Green Cu	20.24
4	3 x #6 THHN Cu	3/4" EMT	#8 Green Cu	60
5	3 x #1 THHN Cu	1.5" EMT	#6 Green Cu	125
6	3 x #3/0 THHN Cu	2" PVC		200
7	3 x #3/0 THHN Cu	2" PVC	#6 Green Cu	200
8	2 x #16 THHN Cu	3/4" EMT		
9	4-conductor shielded (1 twisted pair) 16 AWG	3/4" EMT		
10	Ehternet Wire	3/4" EMT		



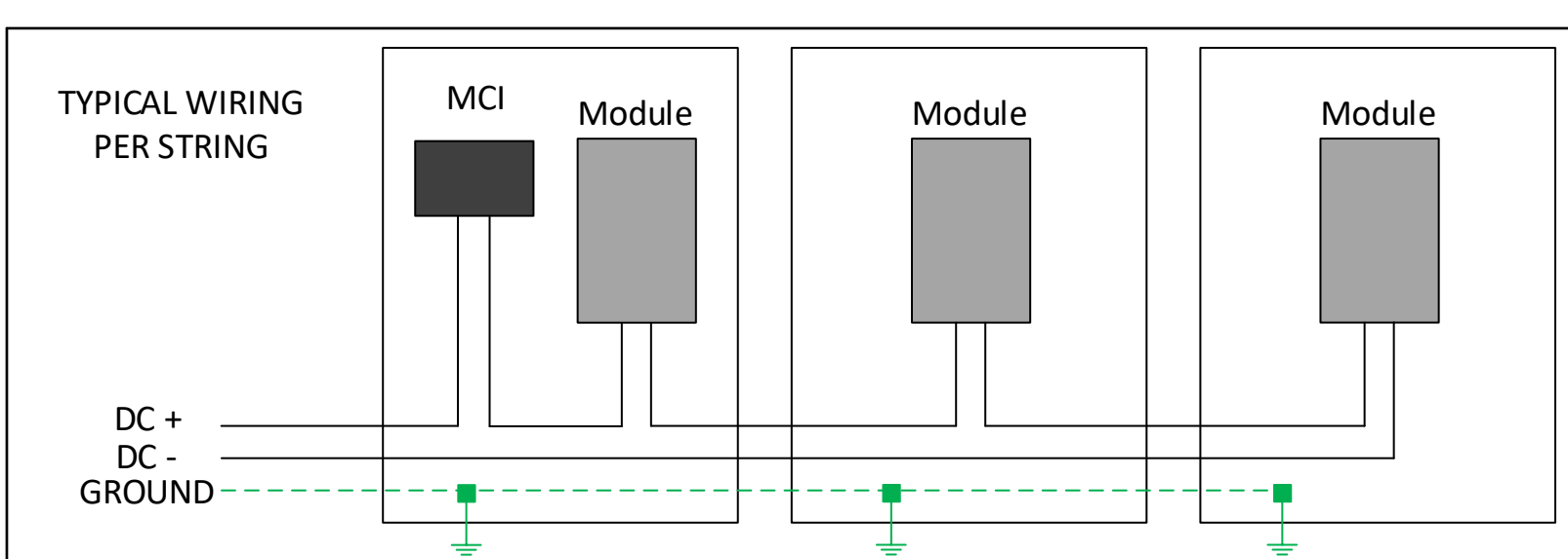

Line 1		<p>Note: Tesla MCI should be at the start or end of every string and it should be after every three panels</p> <p>Note: Loads greater than 48A will not be backed by the battery and needs to be managed manually.</p> <p>Note: Accepted Breakers for Gateway: Eaton CSR or BW (100-200A)</p>
Line 2		
Neutral		
Ground		

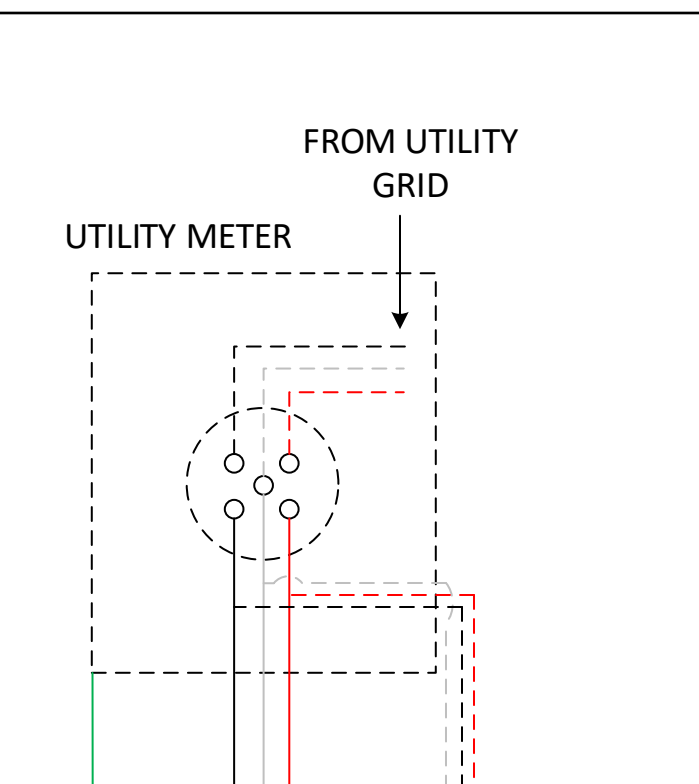

5112 Departure Drive,
Raleigh NC 27616
O: 919.948.6474
E: info@8msolar.com

Tesla Powerwall3 – A (Leader)
1707000-00-J

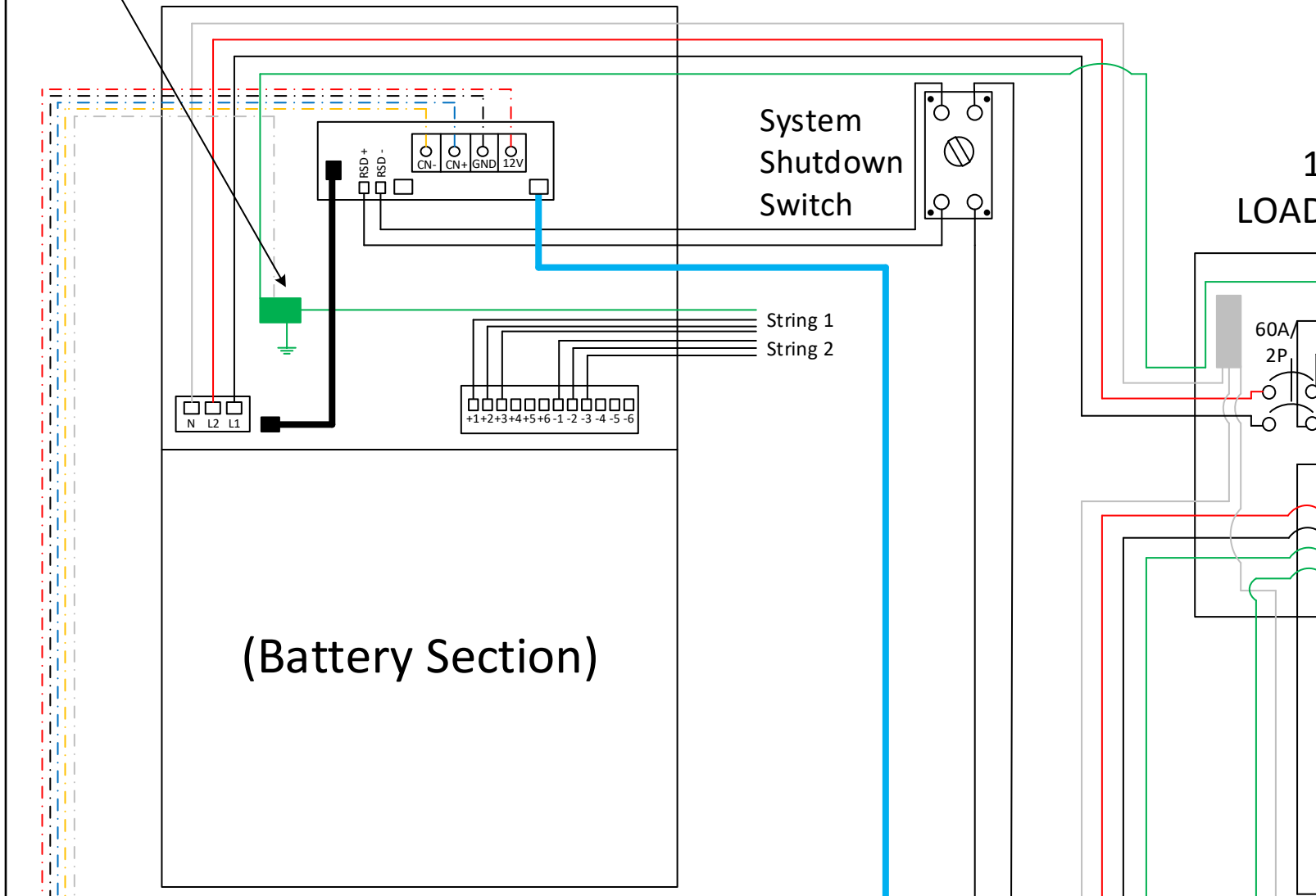

Note: Drain wire in the communication wire should be terminated at the Powerwall3 and it will not be terminated in the Backup Gateway2.

Note: Connect both grounding rods in a series connections with a bare copper keeping the minimum distance of 6ft between them

125A LOAD CENTER

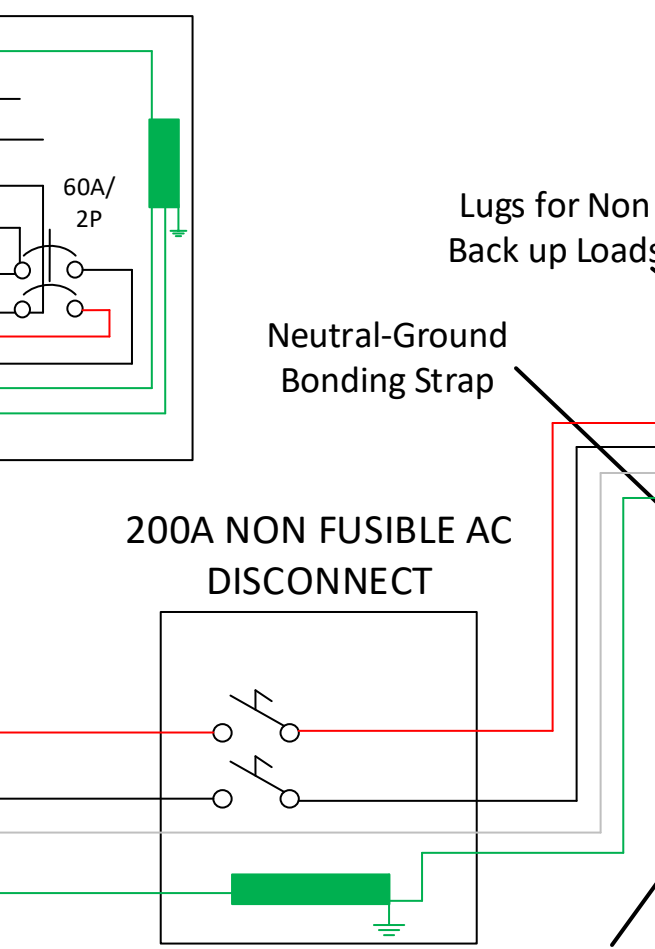

GROUNDING ROD TO BE INSTALLED BY 8MSOLAR

PRE-INSTALLED GROUNDING ROD

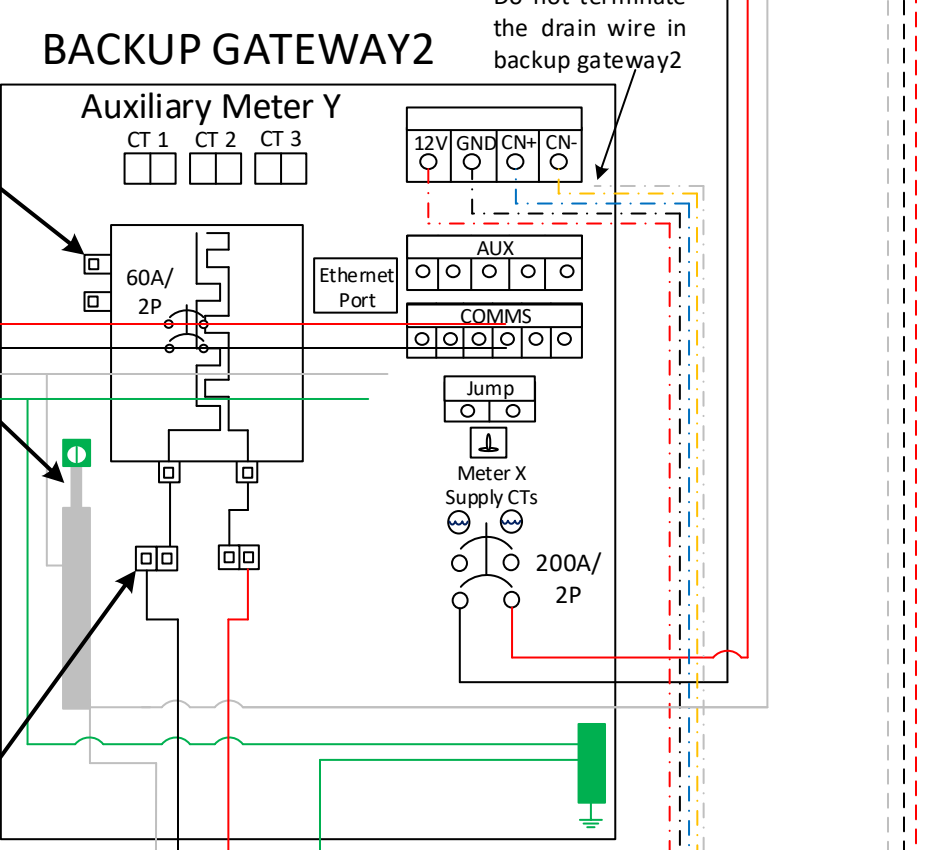

Tesla Powerwall3 – B (Follower)
1707000-00-J

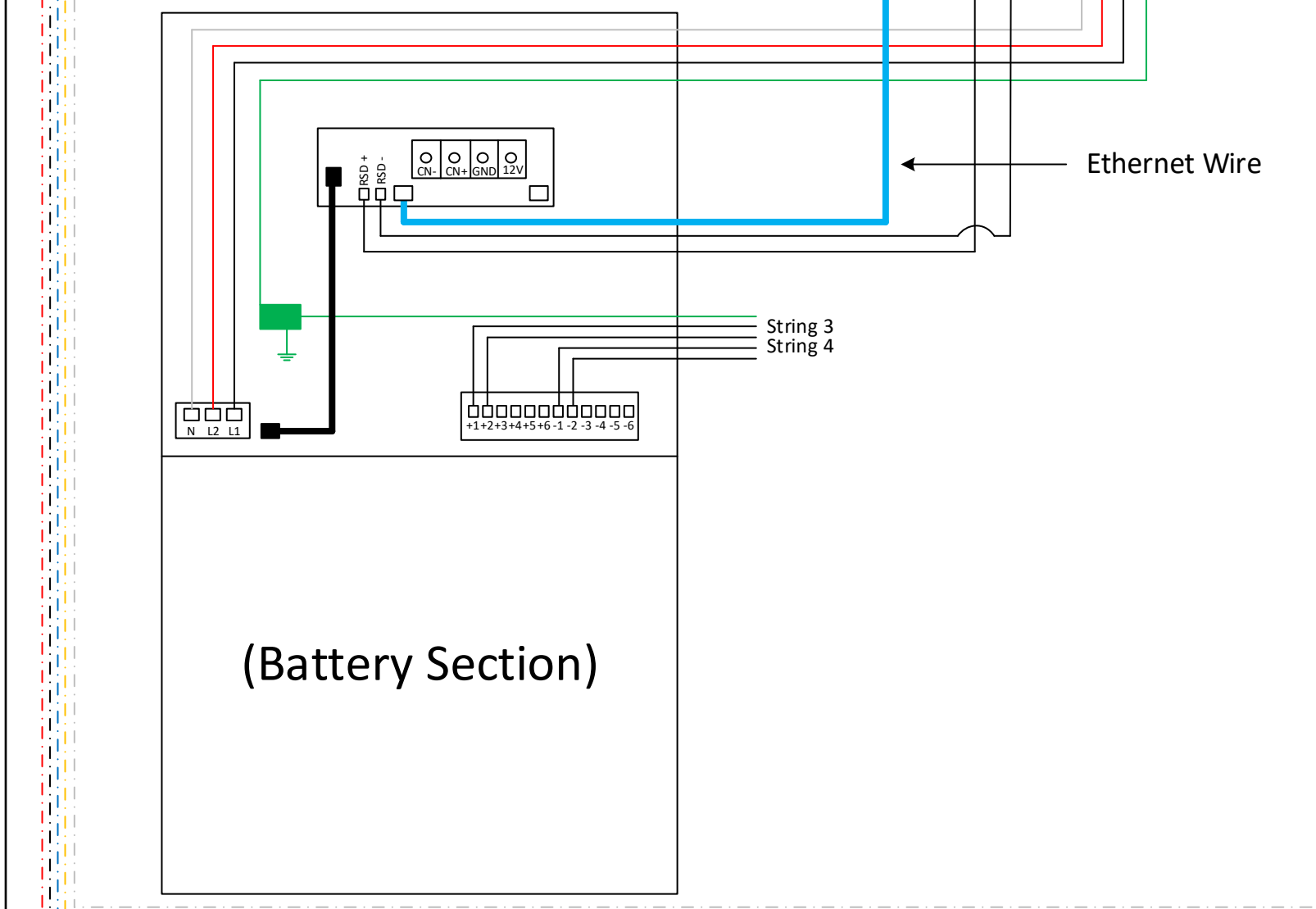

Back up Loads & Generation

ATS

SUB LOAD PANEL
B.B. RATING: 225A
M.B. RATING:

SUB LOAD PANEL
B.B. RATING: 225A
M.B. RATING:

Customer Information:

George B Womble
109 Overlook Court
Angier NC 27501

Customer Signature:

Sheet Name:

Detailed Electrical Diagram

JOB NUMBER:

24-336-GW

Date:

07/02/2024

Revision:

B

Sheet Size:

ANSI C
17" X 22"

Sheet Number:

PV5



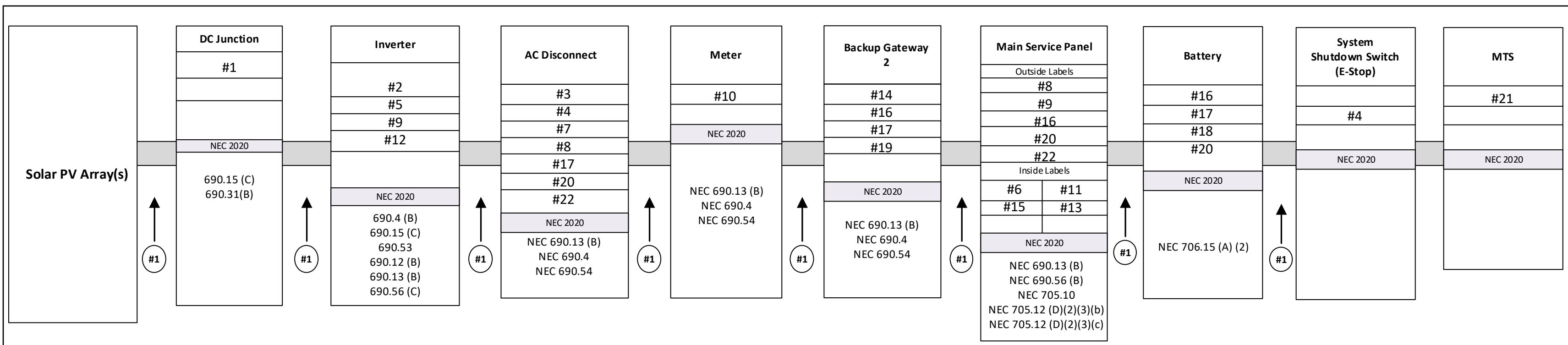

5112 Departure Drive,
Raleigh NC 27616
O: 919.948.6474
E: info@8msolar.com

LABELING AND WARNING SIGNS: NEC 2020

A. PURPOSE
PROVIDE EMERGENCY RESPONDERS WITH APPROPRIATE WARNING AND GUIDANCE WITH RESPECT TO ISOLATING THE SOLAR ELECTRIC SYSTEM. THIS CAN FACILITATE IDENTIFYING ENERGIZED ELECTRICAL LINES THAT CONNECT THE SOLAR PANELS TO THE INVERTER, AS SHOULD NOT BE CUT WHEN VENTING FOR SMOKE REMOVAL.

B. MAIN SERVICE DISCONNECT:
1. RESIDENTIAL BUILDINGS- THE MARKING MAY BE PLACED WITHIN THE MAIN SERVICE DISCONNECT. THE MARKING SHALL BE PLACED ON THE OUTSIDE COVER IF THE MAIN SERVICE DISCONNECT IS OPERABLE WITH THE SERVICE PANEL CLOSED.

2. COMMERCIAL BUILDINGS- THE MARKINGS SHALL BE PLACED ADJACENT TO THE MAIN SERVICE DISCONNECT CLEARLY VISIBLE FROM THE LOCATION WHERE THE LEVER IS OPERATED

3. MARKINGS, VERBIAGE, FORMAT AND TYPE OF MATERIAL
a. VERBIAGE: CAUTION; SOLAR ELECTRIC SYSTEM CONNECTED
b. FORMAT:

- (1) WHITE LETTERING ON A RED BACKGROUND
- (2) MINIMUM 3/8 INCH LETTER HEIGHT
- (3) ALL LETTERS SHALL BE CAPITALIZED
- (4) ARIAL OR SIMILAR FONT, NON-BOLD

c. MATERIAL:
(1) REFLECTIVE, WEATHER RESISTANT MATERIAL SUITABLE FOR THE ENVIRONMENT (USE UL-969) AS STANDARD FOR WEATHER RATING); DURABLE ADHESIVE MATERIALS MEET THIS REQUIREMENT.

C. MARKING REQUIREMENTS ON DC CONDUIT, RACEWAYS, ENCLOSURES, CABLE ASSEMBLIES, DC COMBINERS AND JUNCTION BOXES;

1. MARKING: PLACEMENT, VERBIAGE, FORMAT AND TYPE OF MATERIAL.
a. PLACEMENT: MARKINGS SHALL BE PLACED EVERY 10 (TEN) FEET ON ALL INTERIOR AND EXTERIOR DC CONDUITS, RACEWAYS, ENCLOSURES AND CABLE ASSEMBLIES, AT TURNS ABOVE AND/OR BELOW PENETRATIONS, ALL DC COMBINERS AND JUNCTION BOXES.

b. VERBIAGE: CAUTION SOLAR CIRCUIT
c. THE FORMAT AND TYPE OF MATERIAL SHALL ADHERE TO SECTION B-3.B & C ABOVE

D. INVERTERS ARE NOT REQUIRED TO HAVE CAUTION MARKINGS

<p>#1 WARNING: PHOTOVOLTAIC POWER SOURCE</p> <p>#2 PHOTOVOLTAIC DC DISCONNECT</p> <p>#3 PHOTOVOLTAIC AC DISCONNECT</p> <p>#4 RAPID SHUTDOWN SWITCH FOR SOLAR PV SYSTEM</p> <p>#5 MAXIMUM VOLTAGE 550Vdc MAX. RATED CIRCUIT CURRENT 12.98Adc OF THE CHARGE CONTOLLER OR DC-TO-DC CONVERTER (IF INSTALLED)</p> <p>#6 PHOTOVOLTAIC POWER SOURCE OPERATING AC VOLTAGE 240 V MAXIMUM OPERATING AC OUTPUT CURRENT 48 A</p> <p>#7 AC DISCONNECT PHOTOVOLTAIC SYSTEM POWER SOURCE RATED AC OUTPUT CURRENT 48 AMPS NOMINAL OPERATING AC VOLTAGE 240 VOLTS</p>	<p>#8 WARNING ELECTRIC SHOCK HAZARD TERMINAL ON THE LINE AND LOAD SIDES MAY BE ENERGIZED IN THE OPEN POSITION</p> <p>#9 WARNING DUAL POWER SUPPLY SOURCES: UTILITY GRID AND PV SOLAR ELECTRIC SYSTEM</p> <p>#10 WARNING THREE POWER SOURCES SOURCES: UTILITY GRID, BATTERY AND PV SOLAR ELECTRIC SYSTEM</p> <p>#11 WARNING TURN OFF PHOTOVOLTAIC AC DISCONNECT PRIOR TO WORKING INSIDE PANEL</p> <p>#12 WARNING BIPOLAR PHOTOVOLTAIC ARRAY DISCONNECT OF NEUTRAL GROUNDED CONDUCTORS MAY RESULT IN OVERVOLTAGE ON ARRAY OR INVERTER</p> <p>#13 WARNING POWER SOURCE OUTPUT CONNECTION DO NOT RELOCATE THIS OVERCURRENT DEVICE</p> <p>#14 WARNING SOLAR ELECTRIC CIRCUIT BREAKER IS BACKFEED</p>	<p>#15 SOLAR PV SYSTEM EQUIPPED WITH RAPID SHUTDOWN TURN RAPID SHUTDOWN SWITCH TO THE "OFF" POSITION TO SHUT DOWN PV SYSTEM AND REDUCE SHOCK HAZARD IN THE ARRAY</p> <p>#16 SOLAR AC DISCONNECT LOCATED AT SOUTH-WEST SIDE WALL OF THE HOUSE BESIDE THE UTILITY METER</p> <p>#17 SERVICE DISCONNECT LOCATED IN THE BACKUP GATEWAY23PANEL</p> <p>#18 BATTERY</p> <p>#19 MAIN BATTERY SYSTEM DISCONNECT</p> <p>#20 BATTERY DISCONNECT LOCATED IN THE BACKUP GATEWAY 2 PANEL</p> <p>#21 CAUTION POWER TO THIS BUILDING IS SUPPLIED FROM THE FOLLOWING SOURCES UTILITY GRID ELECTRICAL GENERATOR PV SOLAR ELECTRICAL SYSTEM</p> <p>#22 GENERATOR WILL BE MANAGED BY THE MTS</p>
---	--	---

Customer Information:

George B Womble
109 Overlook Court
Angier NC 27501

Customer Signature:

Sheet Name:

PV Labels

JOB NUMBER:

24-336-GW

Date:

07/02/2024

Revision:

B

Sheet Size:

ANSI C
17" X 22"

Sheet Number:

PV6



ROOF DESCRIPTION			
ROOF	PITCH	AZIMUTH	NO. OF MODULES
A	52°	199°	36

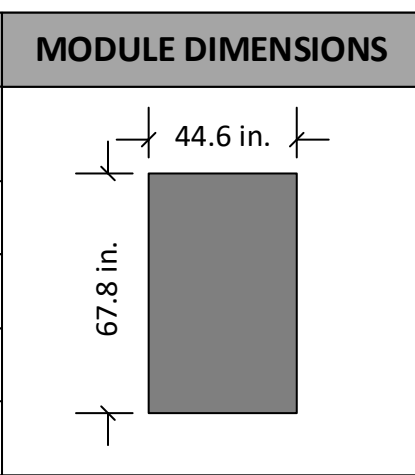

Rails and Splices : PSR-B84 (BLACK)	Roof Attachment : Pegasus Comp Mount
Rafter Spacing : 24 in	There is one layer of shingles Roofing material is asphalt shingles
Attachment Span: 4ft	The roof is located in 115mph wind zone

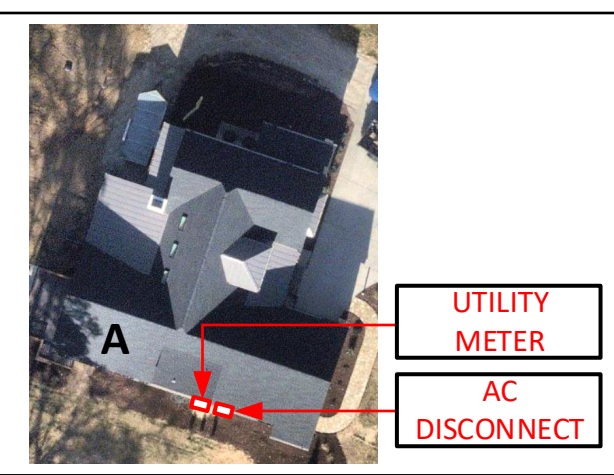

5112 Departure Drive,
Raleigh NC 27616
O: 919.948.6474
E: info@8msolar.com

PV LABELS		
Sr No	Code	Qty
01	02-314	12
02	03-301	01
03	03-302	01
04	02-316	02
05	03-308	01
06	03-390	01
07	03-306	01
08	05-215	02
09	05-211	02
10	03-230	01
11	05-372	01
12	05-103	01
13	05-216	01
14	05-342	02
15	07-111	01
16	8M-001	03
17	8M-002	03
18	03-395	01
19	04-304	01
20	8M-004	03
21	8M-005	01
22	8M-003	03

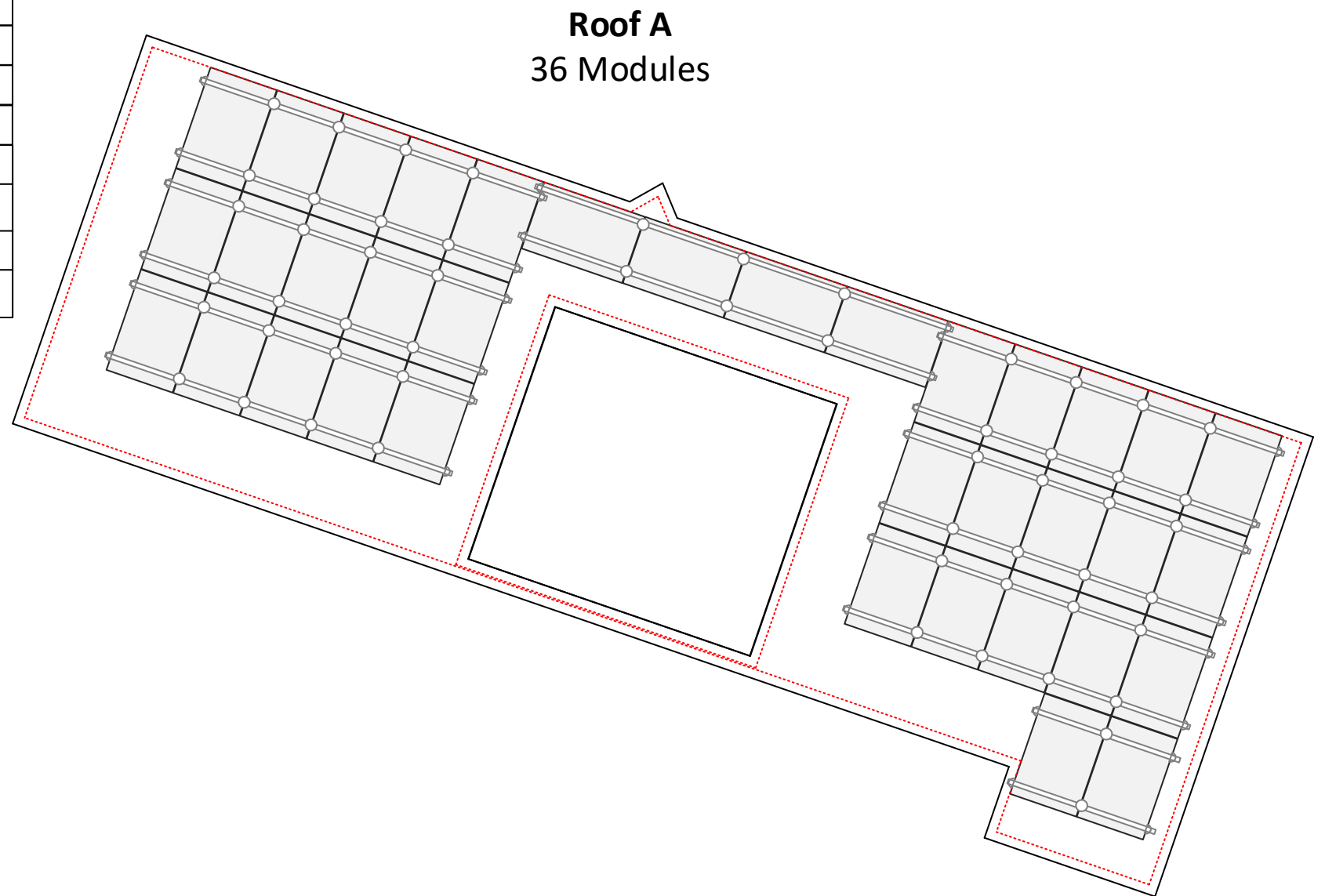

- RAILS AND MOUNTING SYSTEM**
- 48 x PSR-B84: Pegasus Rail, Black, 84" (7 Feet)
 - 32 x PSR-SPL: Pegasus - Bonded, Structural Splice
 - 56 x PSR-MCB: Pegasus - Multiclip, Mid/End, 30 to 40 mm, Black
 - 32 x PSR-HEC: Pegasus - Hidden End Clamp
 - 10 x PSR-LUG: Pegasus - Grounding Lug
 - 54 x PSR-WMC: Pegasus - Wire Management Clip
 - 06 x PSR-CBG: Pegasus - Cable Grip
 - 32 x PSR-CAP: Pegasus - End Cap
 - 76 x PSCR-UBBDT: Pegasus Comp Mount - Open Slot, Black L Foot, Black Flashing, Dovetail 3/8" T-Bolt
 - 72 x Heyco Wire Clips

- SOLAR MODULES**
- 36 x Q.TRON BLK M-G2+ 425W
- INVERTER & SUPPORTING ITEMS**
- 02 x 1707000-00-J :Tesla Powerwall3
 - 12 x 1879359-00-X: Tesla MCI-2
 - 01 x 1232100-00-X: Backup GateWay 2
 - 01 x 1529623-00-X: Internal Panelboard Kit
 - 01 x 1549184-00-X: 02" Conduit Hub Kit
- WIRE**
- 01 x WIRPV 2KVPV10STRBLK500: #10 PV WIRE BLK (Cu) 500ft
- ELECTRICAL ITEMS**
- 01 x BW2200: Gateway Main Breaker-Eaton BW2200
 - 01 x BR2125: Eaton BR 125/2
 - 02 x BR260: Eaton BR 60/2
 - 01 x HOM816L125PRB: Combiner Sub Panel (Sq D HOMELINE) 125A MLO/4-8 space minimum (NEMA 3R)
 - 01 x DG224URK: 250volt/200amp/2pole non fusible disconnect (NEMA 3R)
 - 01 x EATON M22PVK02: EMG STOP W/ CONTACTOR
 - 01 x Eaton M22I1PG: SFC MTG ENC - Emergency Stop Enclosure
 - 01 x EZSLR JB-1.2: SolaDeck

Customer Information:

George B Womble
109 Overlook Court
Angier NC 27501

Customer Signature:

Sheet Name:

Bill of Material

JOB NUMBER:

24-336-GW

Date:

07/02/2024

Revision:

B

Sheet Size:

ANSI C
17" X 22"

Sheet Number:

PV7

6in setback from
sides of the roof

BILL OF MATERIAL
SCALE: 1/8" - 1'

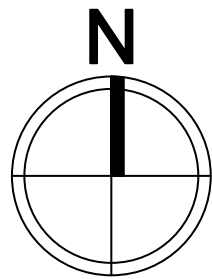

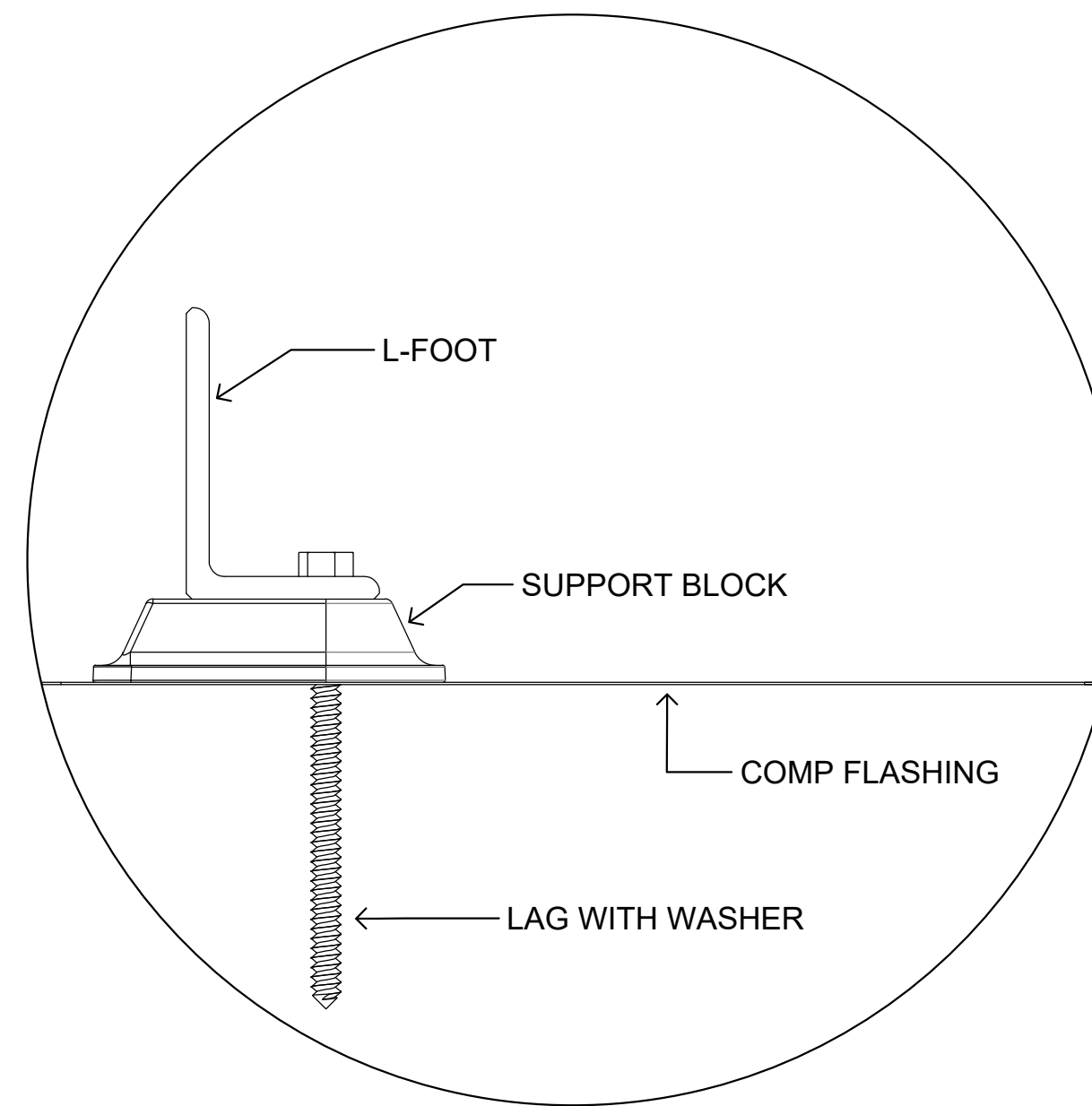
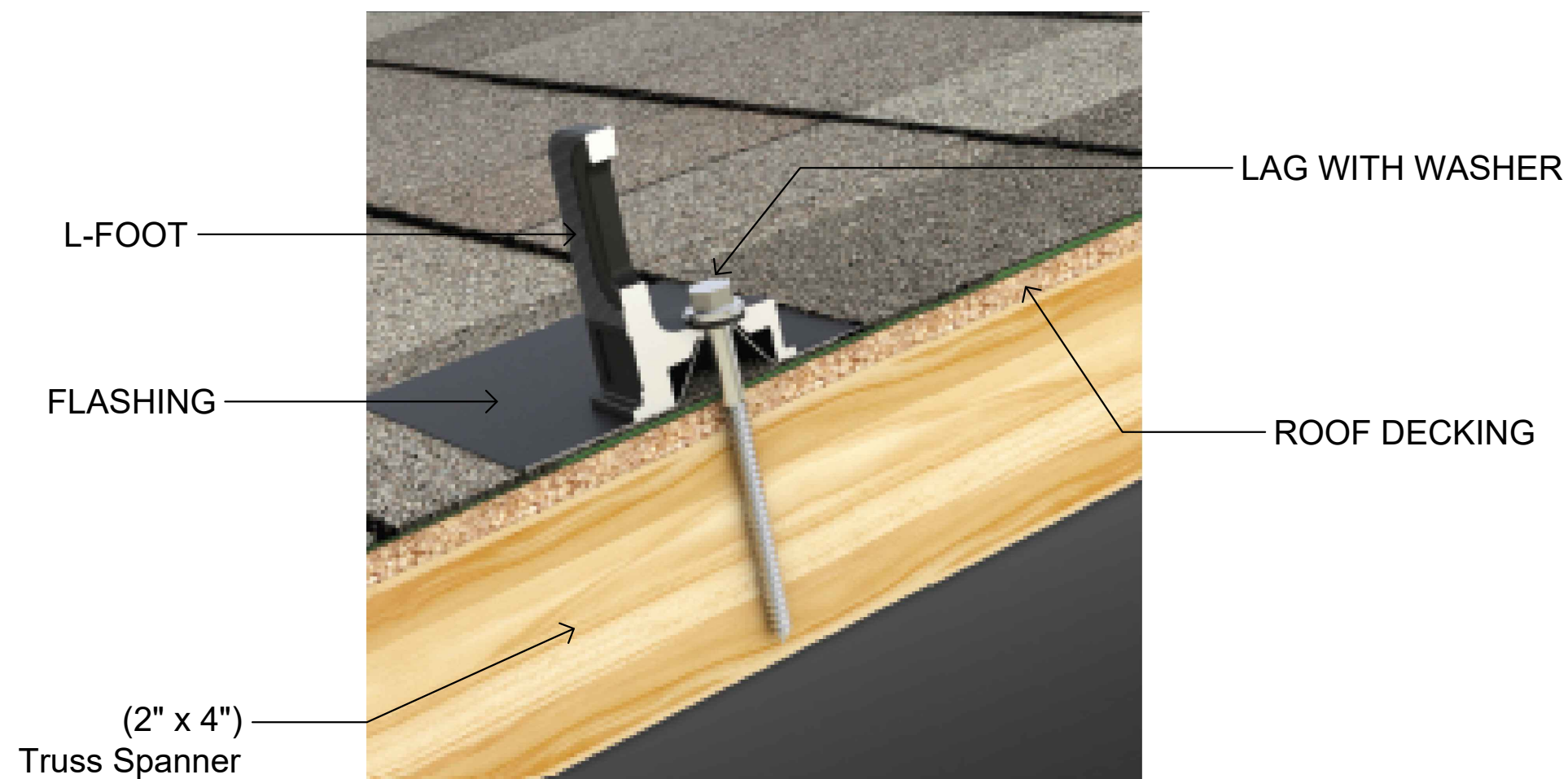







Customer Information:

George B Womble

109 Overlook Court
Angier NC 27501

Customer Signature:

					
Multi-Clamp	Hidden End Clamp	MLPE Mount	Dovetail T-Bolt	Ground Lug	Cable Grip
Torque Value 100 in-lbs.	Torque Value 135 in-lbs.	Torque Value 135 in-lbs.	Torque Value 300 in-lbs.	Torque Value 135 in-lbs.	Torque Value 135 in-lbs.

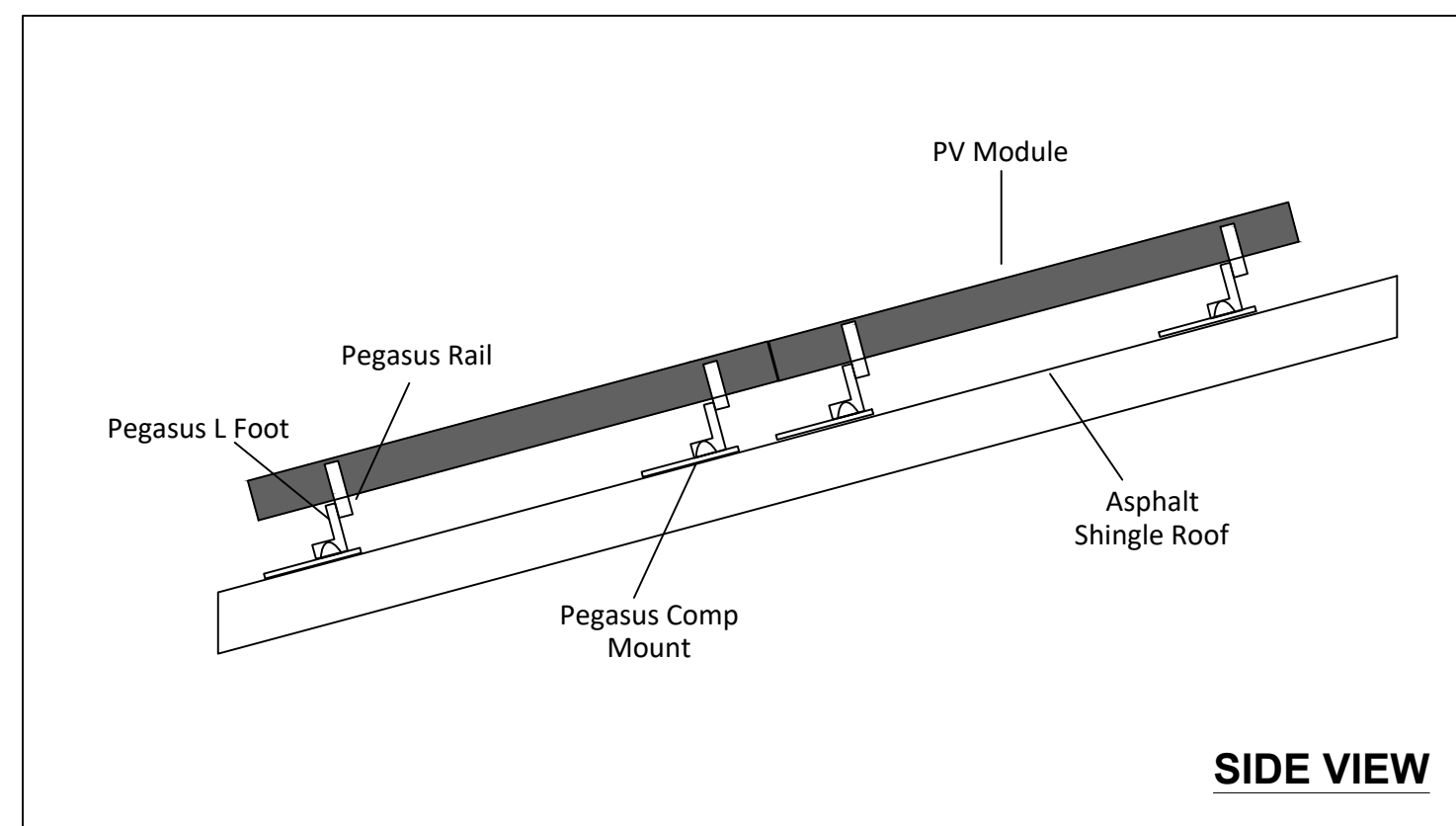

Sheet Name:

Attachment Details

JOB NUMBER:

24-336-GW

Date:

07/02/2024

Revision:

B

Sheet Size:

ANSI C
17" X 22"

Sheet Number:

PV8

PV Dead Load	
Roof A	<p>PV System Dead Load (Panel + Racking weight) / PV System Area (36 panels x 47.2 lbs./panel + 286 ft. of racking x 1.17 lb.ft.) / (36 panels x 5.65' x 3.71') = 2.68 psf</p>

Q.TRON BLK M-G2+ SERIES



405-430 Wp | 108 Cells
22.0% Maximum Module Efficiency

MODEL Q.TRON BLK M-G2+



High performance Qcells N-type solar cells

Q.ANTUM NEO Technology with optimized module layout boosts module efficiency up to 22.0%.



A reliable investment

Inclusive 25-year product warranty and 25-year linear performance warranty¹.



Enduring high performance

Long-term yield security with Anti LeTID Technology, Anti PID Technology², Hot-Spot Protect.



Extreme weather rating

High-tech aluminium alloy frame, certified for high snow (8100 Pa) and wind loads (3600 Pa).



Innovative all-weather technology

Optimal yields, whatever the weather with excellent low-light and temperature behaviour.



The most thorough testing programme in the industry

Qcells is the first solar module manufacturer to pass the most comprehensive quality programme in the industry: The new "Quality Controlled PV" of the independent certification institute TÜV Rheinland.

¹ See data sheet on rear for further information.

² APT test conditions according to IEC/TS 62804-1:2015, method A (-1500 V, 96 h)

The ideal solution for:



Rooftop arrays on residential buildings



Q.TRON BLK M-G2+ SERIES

Mechanical Specification

Format	67.8 in × 44.6 in × 1.18 in (including frame) (1722 mm × 1134 mm × 30 mm)
Weight	46.7 lbs (21.2 kg)
Front Cover	0.13 in (3.2 mm) thermally pre-stressed glass with anti-reflection technology
Back Cover	Composite film
Frame	Black anodised aluminium
Cell	6 × 18 monocrystalline Q.ANTUM NEO solar half cells
Junction box	2.09-3.98 in × 1.26-2.36 in × 0.59-0.71 in (53-101 mm × 32-60 mm × 15-18 mm), Protection class IP67, with bypass diodes
Cable	4 mm ² Solar cable; (+) ≥ 68.9 in (1750mm), (-) ≥ 68.9 in (1750mm)
Connector	Stäubli MC4; IP68

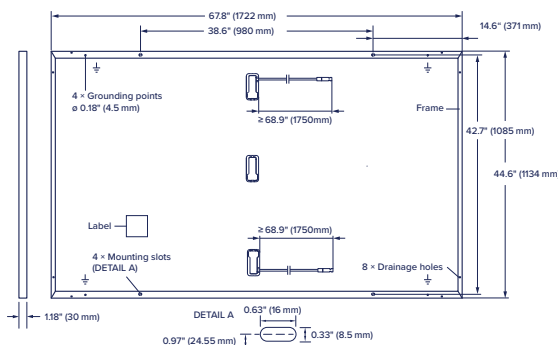

Electrical Characteristics

POWER CLASS		405	410	415	420	425	430	
MINIMUM PERFORMANCE AT STANDARD TEST CONDITIONS, STC ¹ (POWER TOLERANCE +5 W/-0 W)								
Minimum	Power at MPP ¹	P_{MPP} [W]	405	410	415	420	425	430
	Short Circuit Current ¹	I_{SC} [A]	13.33	13.41	13.49	13.58	13.66	13.74
	Open Circuit Voltage ¹	V_{OC} [V]	37.91	38.19	38.47	38.75	39.03	39.32
	Current at MPP	I_{MPP} [A]	12.69	12.76	12.83	12.91	12.98	13.05
	Voltage at MPP	V_{MPP} [V]	31.93	32.13	32.34	32.54	32.74	32.94
	Efficiency ¹	η [%]	≥20.7	≥21.0	≥21.3	≥21.5	≥21.8	≥22.0
MINIMUM PERFORMANCE AT NORMAL OPERATING CONDITIONS, NMOT ²								
Minimum	Power at MPP	P_{MPP} [W]	306.1	309.9	313.7	317.5	321.2	325.0
	Short Circuit Current	I_{SC} [A]	10.74	10.81	10.87	10.94	11.00	11.07
	Open Circuit Voltage	V_{OC} [V]	35.96	36.23	36.50	36.77	37.04	37.31
	Current at MPP	I_{MPP} [A]	9.98	10.04	10.10	10.15	10.21	10.27
	Voltage at MPP	V_{MPP} [V]	30.66	30.87	31.07	31.26	31.46	31.65

¹Measurement tolerances $P_{MPP} \pm 3\%$; I_{SC} ; $V_{OC} \pm 5\%$ at STC; 1000 W/m², 25 ± 2 °C, AM 1.5 according to IEC 60904-3 • ²800 W/m², NMOT, spectrum AM 1.5

Qcells PERFORMANCE WARRANTY

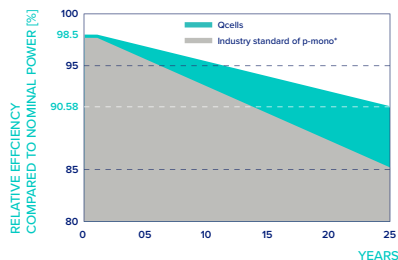

At least 98.5% of nominal power during first year. Thereafter max. 0.33% degradation per year. At least 95.53% of nominal power up to 10 years. At least 90.58% of nominal power up to 25 years.

All data within measurement tolerances. Full warranties in accordance with the warranty terms of the Qcells sales organisation of your respective country.

*Standard terms of guarantee for the 5 PV companies with the highest production capacity in 2021 (February 2021)

PERFORMANCE AT LOW IRRADIANCE

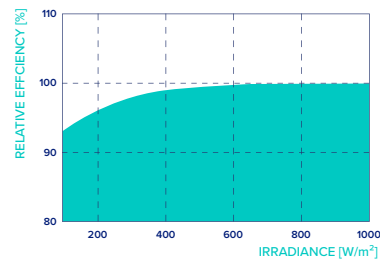

Typical module performance under low irradiance conditions in comparison to STC conditions (25 °C, 1000 W/m²).

TEMPERATURE COEFFICIENTS

Temperature Coefficient of I_{SC}	α [%/K]	+0.04	Temperature Coefficient of V_{OC}	β [%/K]	-0.24
Temperature Coefficient of P_{MPP}	γ [%/K]	-0.30	Nominal Module Operating Temperature	NMOT [°F]	109 ± 5.4 (43 ± 3 °C)

Properties for System Design

Maximum System Voltage	V_{SYS} [V]	1000 (IEC)/1000 (UL)	PV module classification	Class II
Maximum Series Fuse Rating	[A DC]	25	Fire Rating based on ANSI/UL 61730	C / TYPE 2
Max. Design Load, Push/Pull ³	[lbs/ft ²]	113 (5400 Pa)/50 (2400 Pa)	Permitted Module Temperature on Continuous Duty	-40 °F up to +185 °F (-40 °C up to +85 °C)
Max. Test Load, Push/Pull ³	[lbs/ft ²]	169 (8100 Pa)/75 (3600 Pa)		

³ See Installation Manual

Qualifications and Certificates

UL61730-1 & UL61730-2, CE-compliant, Quality Controlled PV - TÜV Rheinland, IEC 61215:2016, IEC 61730:2016, U.S. Patent No. 9,893,215 (solar cells).



*Contact your Qcells Sales Representative for details regarding the module's eligibility to be Buy American Act (BAA) compliant.

Qcells pursues minimizing paper output in consideration of the global environment.

Note: Installation instructions must be followed. Contact our technical service for further information on approved installation of this product.
Hanwha Q CELLS America Inc. 400 Spectrum Center Drive, Suite 1400, Irvine, CA 92618, USA | TEL +1 949 748 59 96 | EMAIL hqc-inquiry@qcells.com | WEB www.qcells.com

qcells

Powerwall 3

Power Everything

—
Powerwall 3 is a fully integrated solar and battery system, designed to accelerate the transition to sustainable energy. Customers can receive whole home backup, cost savings, and energy independence by producing and consuming their own energy while participating in grid services. Once installed, customers can manage their system using the Tesla App to customize system behavior to meet their energy goals.

Powerwall 3 achieves this by supporting up to 20 kW DC of solar and providing 11.5 kW AC of continuous power per unit. It has the ability to start heavy loads up to 150 A LRA, meaning a single unit can support the power needs of most homes. Powerwall 3 is designed for mass production, fast and efficient installations, easy system expansion, and simple connection to any electrical service.



Powerwall 3 Technical Specifications

System Technical Specifications

Model Number	1707000-xx-y
Nominal Grid Voltage (Input & Output)	120/240 VAC
Grid Type	Split phase
Frequency	60 Hz
Overcurrent Protection Device	Configurable up to 60 A
Solar to Battery to Grid Round Trip Efficiency	89% ^{1,2}
Solar to Grid Efficiency	97% ³
Supported Islanding Devices	Backup Gateway 2, Backup Switch
Connectivity	Wi-Fi (2.4 and 5 GHz), Dual-port switched Ethernet, Cellular (LTE/4G ⁴)
Hardware Interface	Dry contact relay, Rapid Shutdown (RSD) certified switch and 2-pin connector, RS-485 for meters
AC Metering	Revenue Grade (+/- 0.5%)
Protections	Integrated arc fault circuit interrupter (AFCI), Isolation Monitor Interrupter (IMI), PV Rapid Shutdown (RSD) using Tesla Mid-Circuit Interrupters
Customer Interface	Tesla Mobile App
Warranty	10 years

Solar Technical Specifications

Maximum Solar STC Input	20 kW
Withstand Voltage	600 V DC
PV DC Input Voltage Range	60 – 550 V DC
PV DC MPPT Voltage Range	150 – 480 V DC
MPPTs	6
Maximum Current per MPPT (I_{mp})	13 A ⁵
Maximum Short Circuit Current per MPPT (I_{sc})	15 A ⁵

Battery Technical Specifications

Nominal Battery Energy	13.5 kWh AC ²
Maximum Continuous Discharge Power	11.5 kW AC
Maximum Continuous Charge Power	5 kW AC
Output Power Factor Rating	0 - 1 (Grid Code configurable)
Maximum Continuous Current	48 A
Maximum Output Fault Current	10 kA
Load Start Capability (1 s)	150 A LRA
Power Scalability	Up to 4 Powerwall 3 units supported

¹ Typical solar shifting use case.

² Values provided for 25°C (77°F), at beginning of life. 3.3 kW charge/discharge power.

³ Tested using CEC weighted efficiency methodology.

⁴ Cellular connectivity subject to network service coverage and signal strength.

⁵ Where the DC input current exceeds the MPPT rating, a jumper can be used to combine two MPPTs into a single input to intake DC current up to 26 A I_{mp} / 30 A I_{sc} .

Powerwall 3 Technical Specifications

Environmental Specifications

Operating Temperature	-20°C to 50°C (-4°F to 122°F) ⁶
Operating Humidity (RH)	Up to 100%, condensing
Storage Temperature	-20°C to 30°C (-4°F to 86°F), up to 95% RH, non-condensing, State of Energy (SOE): 25% initial
Maximum Elevation	3000 m (9843 ft)
Environment	Indoor and outdoor rated
Enclosure Rating	NEMA 3R
Ingress Rating	IPX7 (Battery & Power Electronics) IPX5 (Wiring Compartment)
Pollution Rating	PD3
Operating Noise @ 1 m	< 50 db(A) typical < 62 db(A) maximum

⁶ Performance may be de-rated at operating temperatures above 40°C (104°F).

Compliance Information

Certifications	UL 1642, UL 1699B, UL 1741, UL 1741 SA, UL 1741 SB, UL 3741, UL 1973, UL 1998, UL 9540, IEEE 1547-2018, IEEE 1547.1, UN 38.3
Grid Connection	United States
Emissions	FCC Part 15 Class B
Environmental	RoHS Directive 2011/65/EU
Seismic	AC156, IEEE 693-2005 (high)
Fire Testing	Meets the unit level performance criteria of UL 9540A

Mechanical Specifications

Dimensions	1099 x 609 x 193 mm (43.25 x 24 x 7.6 in)
Weight	130 kg (287 lb)
Mounting Options	Floor or wall mount

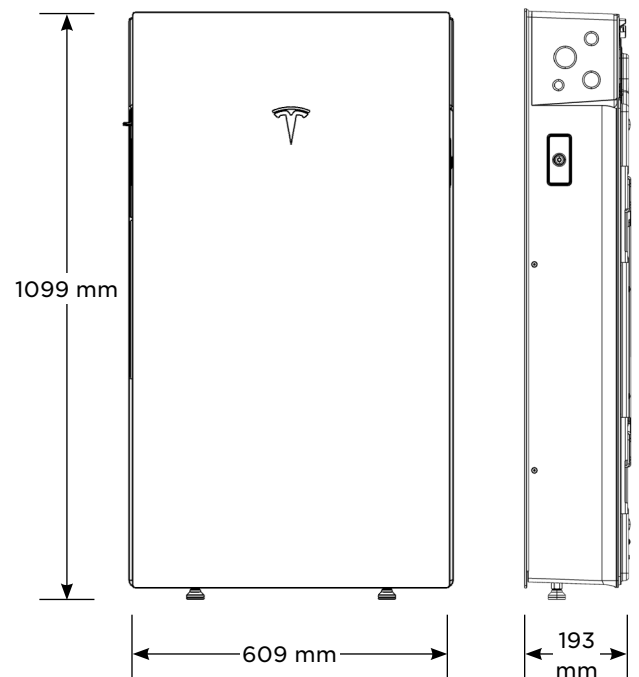

Solar Shutdown Device Technical Specifications

The Solar Shutdown Device is a Mid-Circuit Interrupter (MCI) and is part of the PV system rapid shutdown (RSD) function in accordance with Article 690 of the applicable NEC. When paired with Powerwall 3, solar array shutdown is initiated by any loss of AC power.

Electrical Specifications	Model	MCI-1	MCI-2
	Nominal Input DC Current Rating (I_{MP})	12 A	13 A
	Maximum Input Short Circuit Current (I_{SC})	19 A	17 A
	Maximum System Voltage (PVHCS)	600 V DC	1000 V DC ⁷
⁷ Maximum System Voltage is limited by Powerwall to 600 V DC.			
RSD Module Performance	Maximum Number of Devices per String	5	5
	Control	Power Line Excitation	Power Line Excitation
	Passive State	Normally Open	Normally Open
	Maximum Power Consumption	7 W	7 W
	Warranty	25 years	25 years
Environmental Specifications	Operating Temperature	-40°C to 50°C (-40°F to 122°F)	-45°C to 70°C (-49°F to 158°F)
	Storage Temperature	-30°C to 70°C (-22°F to 158°F)	-30°C to 70°C (-22°F to 158°F)
	Enclosure Rating	NEMA 4X / IP65	NEMA 4X / IP65
Mechanical Specifications	Electrical Connections	MC4 Connector	MC4 Connector
	Housing	Plastic	Plastic
	Dimensions	125 x 150 x 22 mm (5 x 6 x 1 in)	173 x 45 x 22 mm (6.8 x 1.8 x 1 in)
	Weight	350 g (0.77 lb)	120 g (0.26 lb)
	Mounting Options	ZEP Home Run Clip M4 Screw (#10) M8 Bolt (5/16") Nail / Wood screw	Wire Clip
Compliance Information	Certifications	UL 1741 PVRSE, UL 3741, PVRSA (Photovoltaic Rapid Shutdown Array)	
	RSD Initiation Method	External System Shutdown Switch or Powerwall 3 Enable Switch	

UL 3741 PV Hazard Control (and PVRSA) Compatibility

The following categories of solar module meet the UL 3741 PVHCS listing when installed with Powerwall 3 and Solar Shutdown Devices.

Tesla Solar Roof	PV Hazard Control System: BIPV compliance document
Tesla or Hanwha (Q.Peak Duo BLK or BLK-G6+) Modules certified for use with ZEP racking	PV Hazard Control System: ZS PVHCS compliance document
Other module and racking combinations	PV Hazard Control System: Generic PV Array compliance document

Backup Gateway 2

Backup Gateway 2 controls connection to the grid when paired with Powerwall 3, automatically detecting outages and providing seamless transition to backup power. Backup Gateway 2 also provides energy metering for solar self-consumption, time-based control, and backup operation.

In this system configuration, Powerwall 3 acts as the Site Controller, with the Backup Gateway 2 Site Controller disabled.

Performance Specifications

Model Number	1232100-xx-y
AC Voltage (Nominal)	120/240 V
Feed-in Type	Split phase
Grid Frequency	60 Hz
Current Rating	200 A
Maximum Supply Short Circuit Current	10 kA ⁸
Overcurrent Protection Device	100 - 200 A, Service entrance rated ⁸
Overvoltage Category	Category IV
Internal Primary AC Meter	Revenue accurate (+/- 0.2%)
Internal Auxiliary AC Meter	Revenue accurate (+/- 2%)
Primary Connectivity	Ethernet, Wi-Fi
Secondary Connectivity	Cellular (3G, LTE/4G) ⁹

User Interface	Tesla App
Operating Modes	Support for solar self-consumption, time-based control, and backup
Backup Transition	Automatic disconnect for seamless backup
Modularity	Supports up to 10 AC-coupled Powerwalls
Optional Internal Panelboard	200 A 6-space / 12 circuit breakers Siemens QP or Square D HOM breakers rated 10 - 80A or Eaton BR breakers rated 10 - 125A
Warranty	10 years

⁸ When protected by Class J fuses, Backup Gateway 2 is suitable for use in circuits capable of delivering not more than 22kA symmetrical amperes.

⁹ The customer is expected to provide internet connectivity for Backup Gateway 2; cellular should not be used as the primary mode of connectivity. Cellular connectivity subject to network operator service coverage and signal strength.

Environmental Specifications

Operating Temperature	-20°C to 50°C (-4°F to 122°F)
Operating Humidity (RH)	Up to 100%, condensing
Maximum Elevation	3000 m (9843 ft)
Environment	Indoor and outdoor rated
Enclosure Type	NEMA 3R

Compliance Information

Certifications	UL 67, UL 869A, UL 916, UL 1741 PCS, CSA 22.2 0.19, CSA 22.2 205
Emmissions	FCC Part 15, ICES 003

Mechanical Specifications

Dimensions	660 x 411 x 149 mm (26 x 16 x 6 in)
Weight	20.4 kg (45 lb)
Mounting options	Wall mount, Semi-flush mount

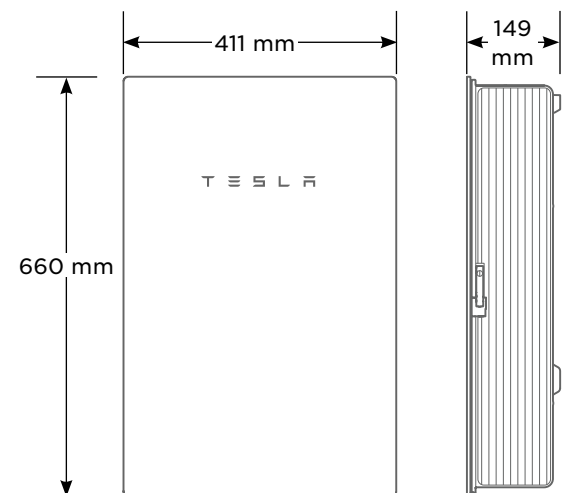

Backup Switch

The Tesla Backup Switch controls connection to the grid in a Powerwall system, and can be easily installed behind the utility meter or in a standalone meter panel downstream of the utility meter.

The Backup Switch automatically detects grid outages, providing a seamless transition to backup power. It communicates directly with Powerwall, allowing home energy usage monitoring from any mobile device with the Tesla app.

Performance Specifications

Model Number	1624171-xx-y
Continuous Load Rating	200 A, 120/240 V split phase
Maximum Supply Short Circuit Current	22 kA with breaker ¹⁰
Communication	CAN
AC Meter	Revenue accurate (+/- 0.5%)
Expected Service Life	21 years
Warranty	10 years

¹⁰ Breaker maximum supply short circuit current rating must be equal to or greater than the available fault current.

Environmental Specifications

Operating Temperature	-40°C to 50°C (-40°F to 122°F)
Storage Temperature	-40°C to 85°C (-40°F to 185°F)
Enclosure Rating	NEMA 3R
Pollution Rating	PD3

Compliance Information

Safety Standards	USA: UL 414, UL 2735, UL 916, CA Prop 65
Emmissions	FCC, ICES

Mechanical Specifications

Dimensions	176 x 205 x 74 mm (6.9 x 8.1 x 2.9 in)
Weight	2.8 lb
Meter and Socket Compatibility	ANSI Type 2S, ringless or ring type
External Service Interface	Contactor manual override ¹¹ Reset button
Conduit Compatibility	1/2-inch NPT

¹¹ Manually overrides the contactor position during a service event.

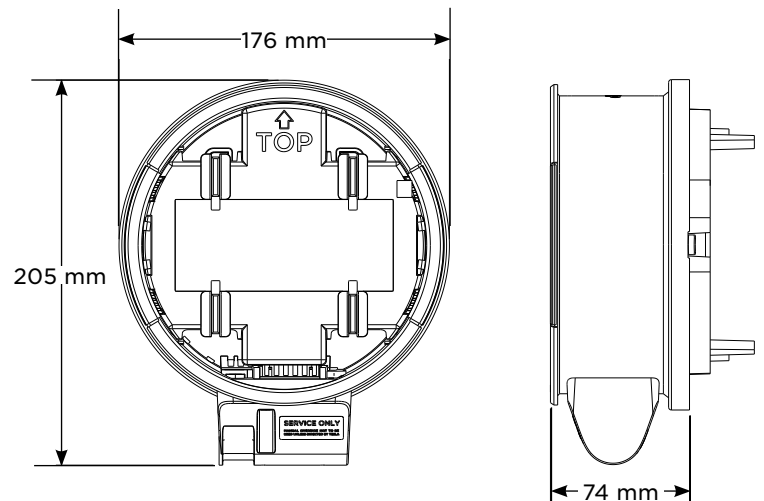

Powerwall 3 Example System Configurations

Powerwall 3 with Backup Switch

Whole Home Backup

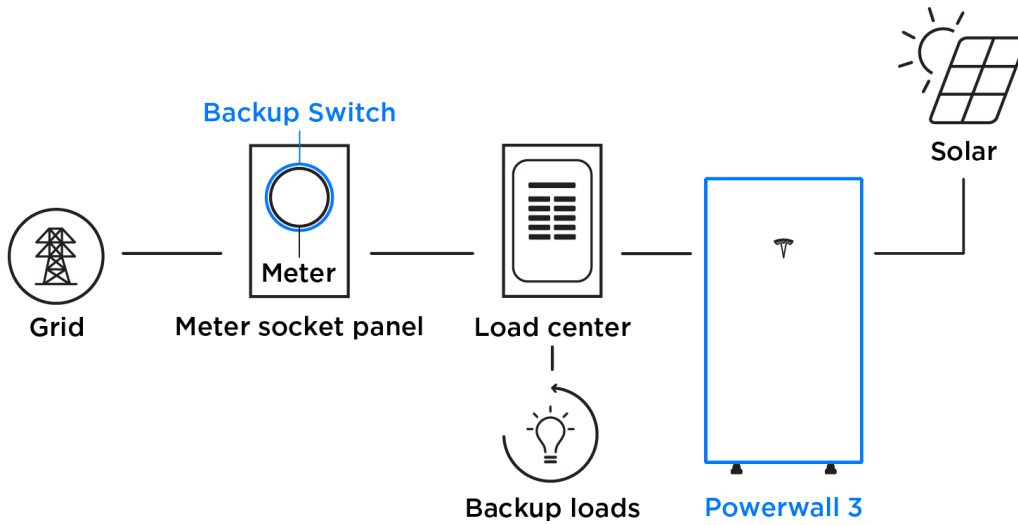

Powerwall 3 with Backup Gateway 2

Partial Home Backup

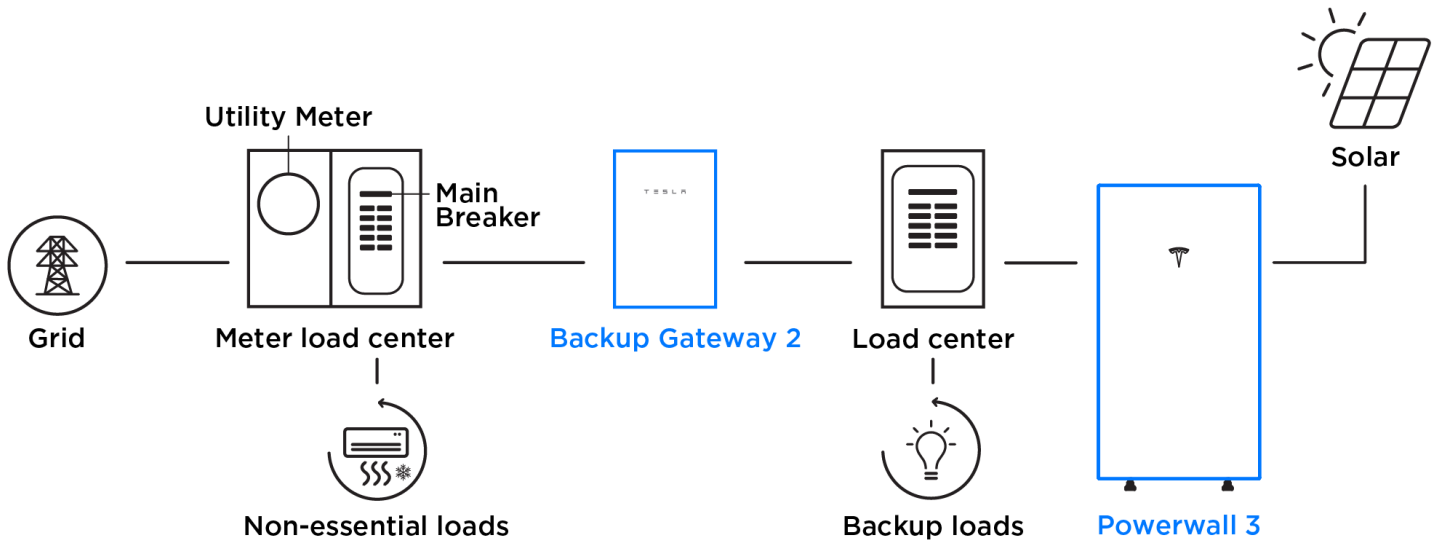

One Clamp Anywhere

The Multi-Clamp works as mid- or end-clamp, and fits standard 30-40mm frames.

Instant Bonding

The N-S Bonding Jumper bonds row to row with no tools.

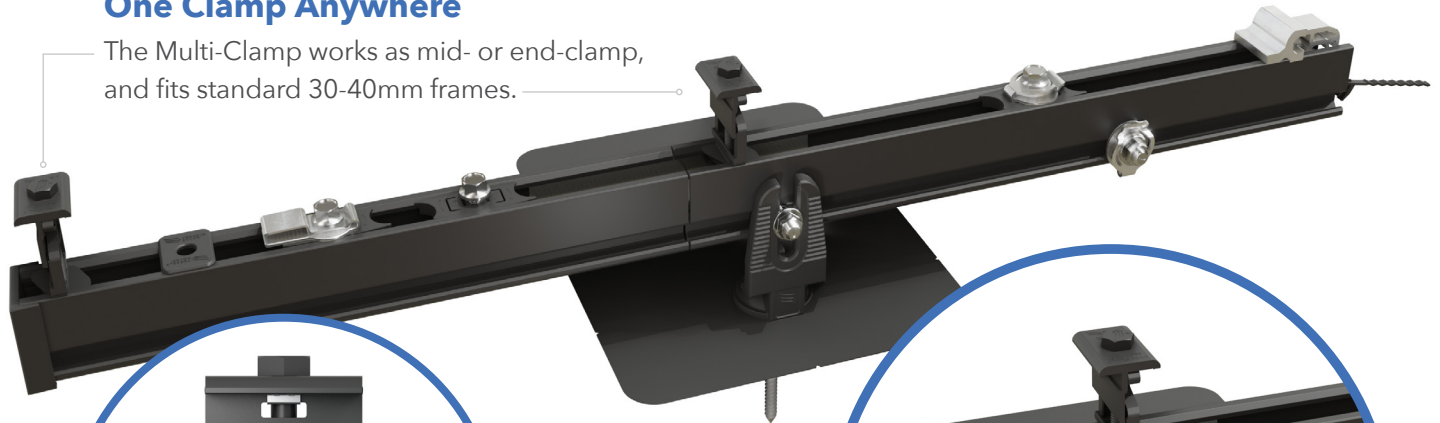

Lifetime Wire Management

Open rail channel holds and protects wires. Clamps won't pinch wires after tightening.

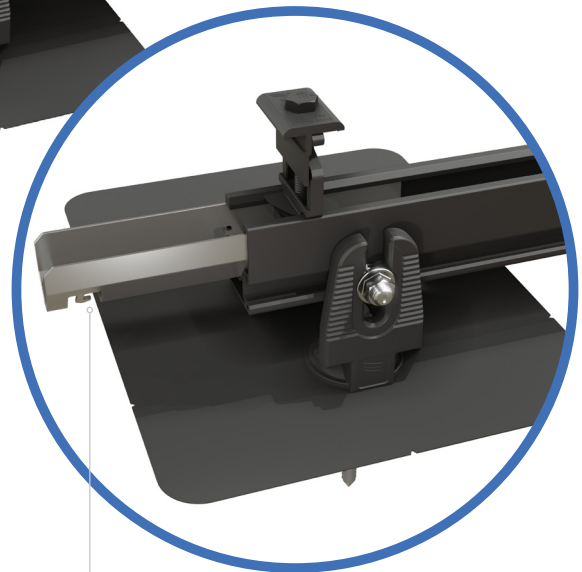

Bonding Structural Splice

Connect rails instantly, without tools, interference or limitations.

Next-Level Solar Mounting

A complete system for hassle-free rooftop installation, from watertight mounts to lifetime wire management.



Simplicity

1/2" socket for everything.
One clamp for mid or end.
No tool splicing and bonding.
Easy wire management.



Code Compliant

UL 2703 listed
LTR-AE-001-2012 listed
Class A fire rating for any slope
ASCE 7-16 PE Certified



Premium Aesthetics

The narrowest panel gap available. Optional Hidden End Clamps and End Caps provide a flush look on the edge of the array.



Watertight for Life

Secured on industry-leading Pegasus Mounts, for composite shingle and tile roofs. Backed by a 25-year warranty.

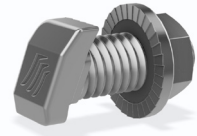
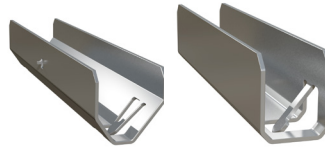
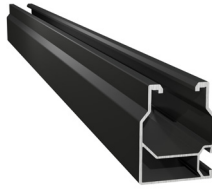

Pegasus Rail	Pegasus Max Rail	Splice and Max Splice	Dovetail T-bolt
--------------	------------------	-----------------------	-----------------

Available in 14' and 7' lengths for easy layout and shipping.
Open-channel design holds MC4 connectors, PV wire and trunk cables.
Black and Mill finish

Maximum-strength design.
Meets specifications for high snow-load and hurricane zones.
Black and Mill finish

Installs by hand.
Works over mounts.
Structurally connects and bonds rails automatically; UL2703 listed as reusable.

Dovetail shape for extra strength.
Uses 1/2" socket.



Multi-Clamp	Hidden End Clamp	Ground Lug	N-S Bonding Jumper
-------------	------------------	------------	--------------------

Fits 30-40mm PV frames, as mid- or end-clamp.
Twist-locks into position; doesn't pinch wires in rail.
Bonds modules to rail; UL2703 listed as reusable

Offers premium edge appearance.
Preinstalled pull-tab grips rail edge, allowing easy, one-hand installation.
Tucks away for reuse.

Holds 6 or 8 AWG wire.
Mounts on top or side of rail.
Assembled on MLPE Mount.
UL2703 listed as reusable.

Installs by hand, eliminates row-to-row copper wire.
UL2703 listed as reusable only with Pegasus Rail.

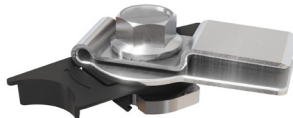
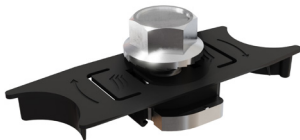

MLPE Mount	Cable Grip	Wire Clip	End Cap and Max End Cap
------------	------------	-----------	-------------------------

Secures and bonds most micro-inverters and optimizers to rail.
Connectors and wires easily route underneath after installation.
UL2703 listed as reusable.

Secures four PV wires or two trunk cables.
Stainless-steel backing provides durable grip.
Eliminates sagging wires.

Hand operable.
Holds wires in channel.
Won't slip.

Fits flush to PV module and hides row or angled cuts.
Hidden drain quickly clears water from rail.

Certifications:

- UL 2703, Edition 1
- LTR-AE-001-2012
- ASCE 7-16 PE certified
- Class A fire rating for any slope roof



Quickly calculate the most efficient layout, spans and materials needed to suit your job. Visit the Pegasus Customer Portal. pegasussolar.com/portal

LOAD		SPAN			
SNOW (PSF)	WIND (MPH)	32"	4'	6'	8'
0	120	PEGASUS RAIL			
	160	PEGASUS RAIL			PEGASUS MAX RAIL
	190	PEGASUS RAIL		PEGASUS MAX RAIL	
15	140	PEGASUS RAIL			PEGASUS MAX RAIL
	160	PEGASUS RAIL		PEGASUS MAX RAIL	
30	160	PEGASUS RAIL		PEGASUS MAX RAIL	
	190	PEGASUS RAIL		PEGASUS MAX RAIL	
45	190	PEGASUS RAIL		PEGASUS MAX RAIL	
70	190	PEGASUS RAIL		PEGASUS MAX RAIL	
110	190	PEGASUS RAIL		PEGASUS MAX RAIL	

For reference only. Spans above are calculated using ASCE 7-16 for a Gable Roof, Exposure Category B, 7-20deg roof angle, 30ft mean roof height with non-exposed modules. For PE certified span tables, visit www.pegasussolar.com/spans.

Patents pending. All rights reserved. ©2021 Pegasus Solar Inc.

COMP MOUNT

One-Piece Flashing with Elevated Cone

No press-fits or deck-level EPDM washers to fail

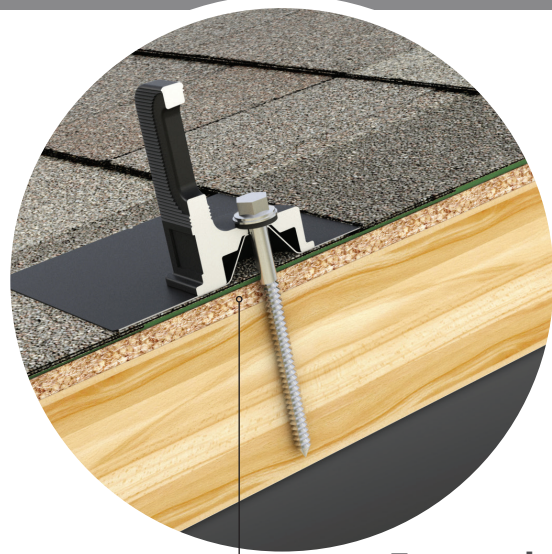

Encapsulating Design

Raises the water seal 0.9" Above roof deck



Simple 3-Piece Design Watertight For Life

Pegasus solar's comp mounts are a cost effective, high-quality option for rail installations on composition shingle roofs. Designed to last decades, the one-piece flashing with elevated cone means there is simply nothing to fail.



25-Year Warranty

Manufactured with advanced materials and coatings to outlast the roof itself



Code Compliant

Fully IBC/CBC Code Compliant
Exceeds ASCE 7-16 Standards



Superior Waterproofing

Tested to AC286 without sealant
Water seal elevated 0.9" above



All-In-One Kit Packaging

Flashings, L-Feet and SS lags with bonded EPDM washers are included in each 24-pack

1

Drill pilot hole in the center of the rafter.

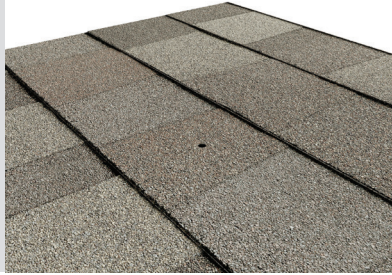

2

Optional: Apply a "u-shape" of sealant to the underside of the flashing and position under 2nd shingle course, cone over pilot hole.

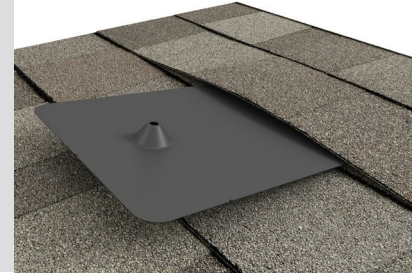

3

Place L-Foot over cone and install lag with washer through L-Foot.

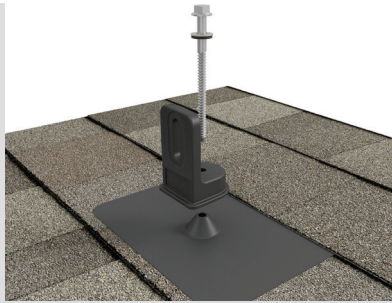

4

Drive lag to required depth. Attach rail per rail manufacturer's instructions.

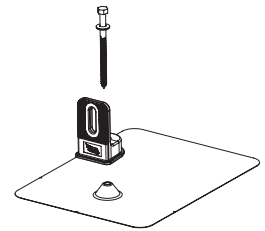
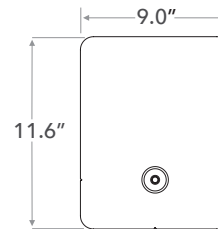
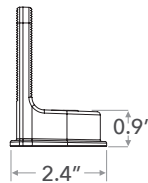
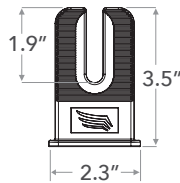
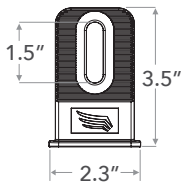
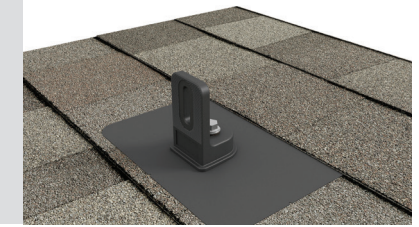

SPECIFICATIONS	COMP MOUNT INSTALL KITS				
SKU	PSCR-CBB0	PSCR-UBB0	SPCR-CBBH	PSCR-CMM0	PSCR-UMM0
Finish	Black L-Foot And Black Flashing			Mill	
L-Foot Type	Closed Slot	Open Slot	Closed Slot	Closed Slot	Open Slot
Kit Contents	L-Foot, Flashing, 5/16" x 4 1/2" SS Lag with metalized EPDM washer	L-Foot, Flashing, 5/16" x 4 1/2" SS Lag with metalized EPDM washer and M10 Hex Bolt	L-Foot, Flashing, 5/16" x 4 1/2" SS Lag with metalized EPDM washer	L-Foot, Flashing, 5/16" x 4 1/2" SS Lag with metalized EPDM washer	L-Foot, Flashing, 5/16" x 4 1/2" SS Lag with metalized EPDM washer
Roof Type	Composition Shingle				
Certifications	IBC, ASCE/SEI 7-16, AC286				
Install Application	Railed Systems				
Compatible Rail	Most				
Kit Quantity	24				
Boxes per Pallet	72				

Protected under US Patent: 10,998,847. Additional patents pending. All rights reserved. ©2021 Pegasus

COMP ACCESSORY MOUNT

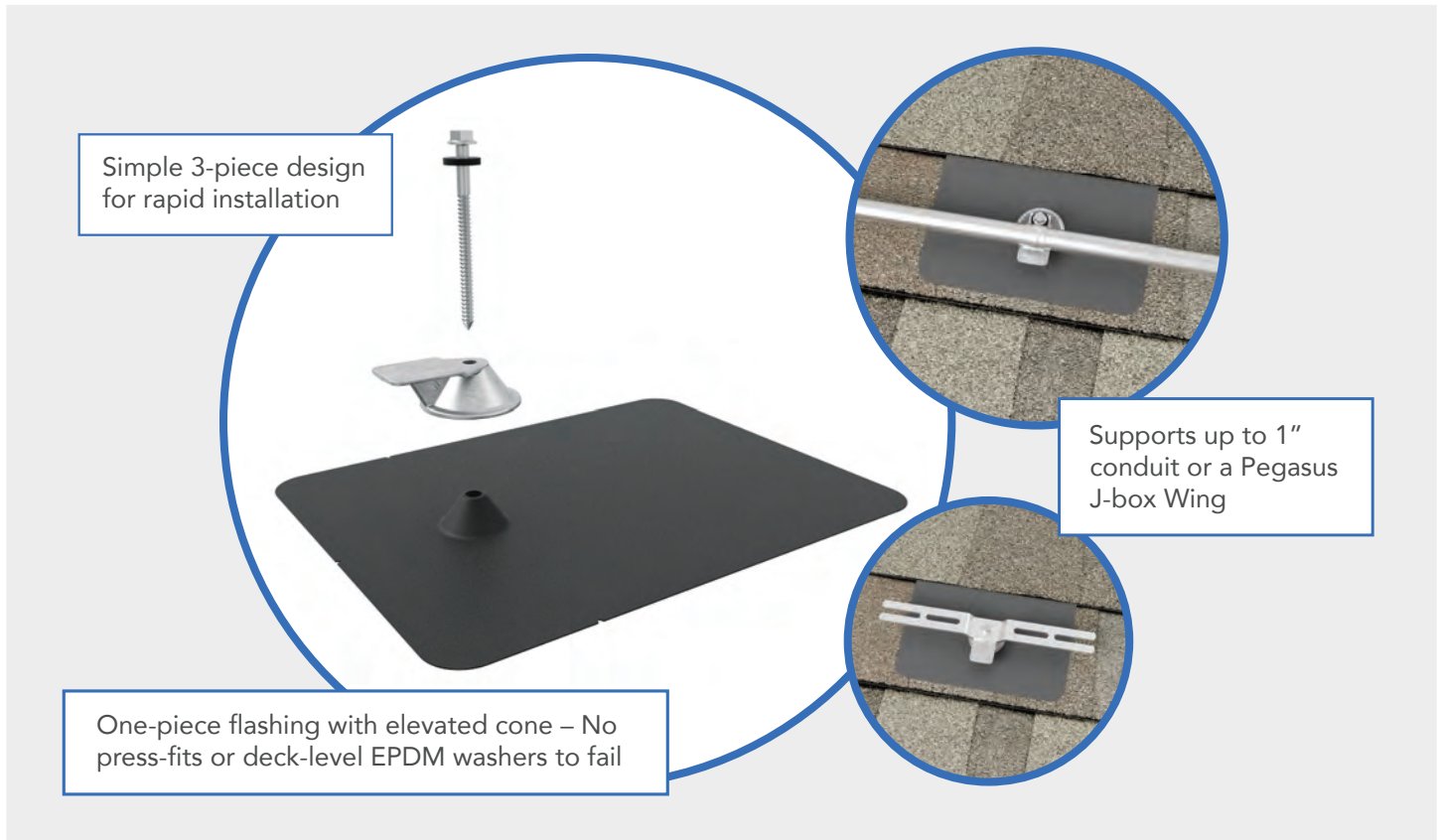

WATERTIGHT FOR LIFE

Pegasus Solar's Comp Accessory Mount secures conduit, a junction box, or other accessories on composition shingle roofs. Designed to last decades, the one-piece flashing with elevated cone means there is simply nothing to fail.



25-year Warranty

Manufactured with advanced materials and coatings to outlast the roof itself



Superior Waterproofing

Tested to AC286 without sealant
0.9" elevated water seal



Code Compliant

Securely holds conduit 1" above roof surface



All-In-One Kit Packaging

Flashings, Support Blocks, and SS lags with EPDM washers are included in each 12-pack

COMP ACCESSORY MOUNT

1. Drill pilot hole into roof decking.

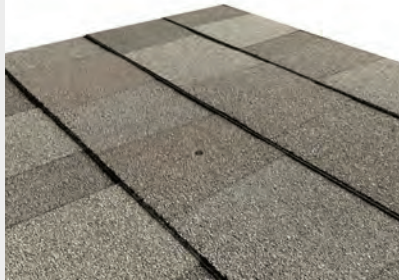

2. Optional: Apply a "U-shape" of sealant to underside of flashing and position under 2nd shingle course, cone over pilot hole.

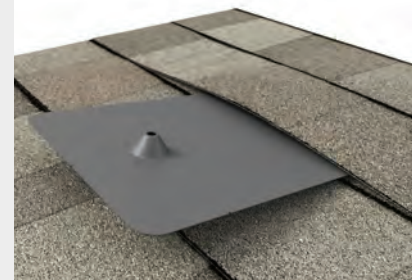

3. Place support block over cone and install lag through one-hole strap and EPDM washer.

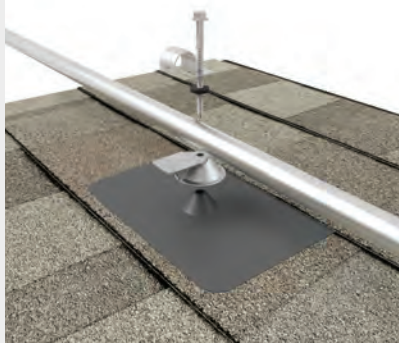

4. Drive lag into roof decking until secure.

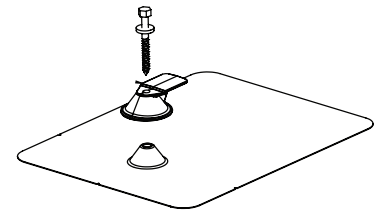
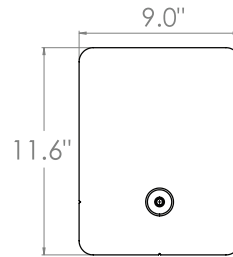
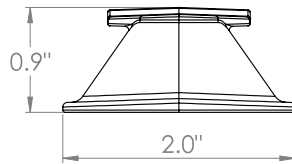
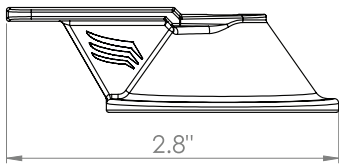
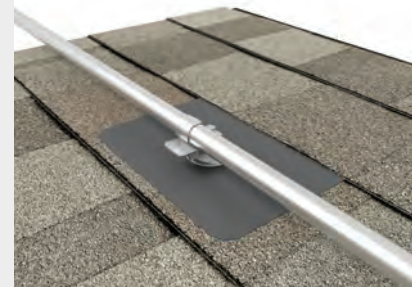

Specifications	Comp Accessory Mount Kits	
SKU	PSCA-0MB0	PSCA-0MM0
Finish	Black Flashing, Mill Support Block	Mill Flashing, Mill Support Block
Kit Contents	Flashing, Support Block, 1/4" x 2.5" SS lag screw w/ EPDM washer	
Application	Conduit and Pegasus' J-box wing (P/N: PSUA-JM)	
Conduit Sizes	Up to 1 inch	
Roof Type	Composition Shingle	
Flashing Material	Painted Galvalume Plus	Galvalume Plus
Support Block Material	Aluminum	
Kit Quantity	12	
Boxes per Pallet	216	

Patents Pending. All rights reserved. © 2019 Pegasus Solar Inc.

SolaDeck

PV ROOF-MOUNT ENCLOSURE

**INTRODUCED AT
*SOLAR POWER 2007***



**UL50 Type 3R Enclosure • Stamped 18 gauge gal. steel • Powder coated finish
• Weather tight**



Enclosure Includes:

- Dual ground lug
- Universal DIN rail
- 1/2", 3/4" & 1" knockouts
- Wire strain relief clip
- Complete hardware package

PV Roof-Mount Combiner/Enclosure

Benefits

- The ability to prep the building is now possible
- Replaces several parts used today
- Provides professional looking install
- Saves time on install
- Allows for easy access
- Guaranteed seal to roof
- Low profile design

***For product information contact us at
(866) 367-7782***

www.commdeck.com



RSTC Enterprises, Inc
2219 Heimstead Road
Eau Claire, WI 54703
1 (866) 367 - 7782



SolaDeck Part # 780

Specifications:

18 Gauge Steel Base (1) and Cover (2)
Pre Punched 7 holes in base (1) for roof deck
Pre Punched 4 holes in base (1) and cover (2) for match
Draw Process both parts
Powder Coated to withstand 1000 hours Salt Spray (Primer Gray)
High UV resistance
15" x 15" flashing dimension
Cavity dimension 8"W x 9" L x 2.5"D
Approx. 162 Cubic inch equipment cavity
Norloked steel base plate (3) to drawn base (2)
Three knockout locations .5", .75" and 1"
3" DIN rail installed
Grounding Lug- Installed (In Equipment Cavity)
Wire Strain Relief Clip –Installed (In Equipment Cavity)
Hardware pack withstands 500 hours Salt Spray
7 - 2" Trusshead Screws
4 - .5" 8-32 thread cutting screws
4 - #10 Bonded Seal washers
1 – Foam closed Cell Seal
ETL Listed UL50 Type 3R

Total Weight 6.9 pounds each

Packaging:

Individually bagged and boxed
Box dimension 15.5"w x 16" L x 3" D
White Carton labeled with Cut out template
Print One Color - Black

Master Cartons of 6 Units each
Master Carton dimension 18.75"x16"x16.375"
Master Carton Weight – 42 pounds
18 Master Cartons per skid Approx 800 pounds with skid

Eaton DG222URB

Catalog Number: DG222URB

Eaton General duty non-fusible safety switch, single-throw, 60 A, NEMA 3R, Rainproof, Painted galvanized steel, Two-pole, Two-wire, 240 V

Photo is representative



General specifications

Product Name

Eaton general duty non-fusible safety switch

Catalog Number

DG222URB

UPC

782113144238

Product Length/Depth

7.38 in

Product Height

14.38 in

Product Width

8.69 in

Product Weight

9 lb

Warranty

Eaton Selling Policy 25-000, one (1) year NEC 230.62 (C) Compliant Barrier from the date of installation of the Product or eighteen (18) months from the date of shipment of the Product, whichever occurs first.

Compliances

Certifications

UL Listed

Catalog Notes

WARNING! Switch is not approved for service entrance unless a neutral kit is installed.

defaultTaxonomyAttributeLabel

Type

Non-fusible, single-throw

Amperage Rating

60A

Number Of Poles

Two-pole

Product Category

General duty safety switch

Voltage rating

240V

Enclosure

NEMA 3R

Enclosure material

Painted galvanized steel

Fuse configuration

Non-fusible

Number of wires

2

Resources

Catalogs

[Eaton's Volume 2—Commercial Distribution](#)

Multimedia

[Double Up on Safety](#)

[Switching Devices Flex Center](#)

Specifications and datasheets

[Eaton Specification Sheet - DG222URB](#)

Warranty guides

[Selling Policy 25-000 - Distribution and Control Products and Services](#)



Eaton Corporation plc
Eaton House
30 Pembroke Road
Dublin 4, Ireland
Eaton.com

© 2024 Eaton. All Rights Reserved.

Eaton is a registered trademark.

All other trademarks are property of their respective owners.



Eaton.com/socialmedia