

**PHOTOVOLTAIC ROOF MOUNT SYSTEM  
8.505kWDC,11.500kWAC  
13.500kWh ENERGY STORAGE SYSTEM  
151 FIELDSTONE DR, HOLLY SPRINGS, NC  
27540**

**AHJ:**  
COUNTY OF HARNETT

**UTILITY:**  
DUKE ENERGY CAROLINAS, LLC

**GOVERNING CODES WITH AMENDMENTS:**

2018 NORTH CAROLINA BUILDING CODE  
2018 NORTH CAROLINA RESIDENTIAL CODE  
2018 NORTH CAROLINA FIRE CODE  
2017 NATIONAL ELECTRICAL CODE

WIND SPEED: 115 MPH  
SNOW LOAD: 15 PSF

**SCOPE OF WORK**

- (N) 8.505KWDC,(N) 11.500KWAC ROOF MOUNTED PV SYSTEM
- (N) 13.500KWh ENERGY STORAGE SYSTEM
- (N) (21) ZNSHINESOLAR ZXM7-SH108 405W SOLAR MODULES
- (N) (8) MID-CIRCUIT INTERRUPTER
- (N) (1) TESLA 1707000-XX-Y POWERWALL 3 WITH INTEGRATED INVERTER
- (N) (1) 200A TESLA BACKUP GATEWAY 2
- (N) (1) ESS DISCONNECT SWITCH

**VICINITY MAP**

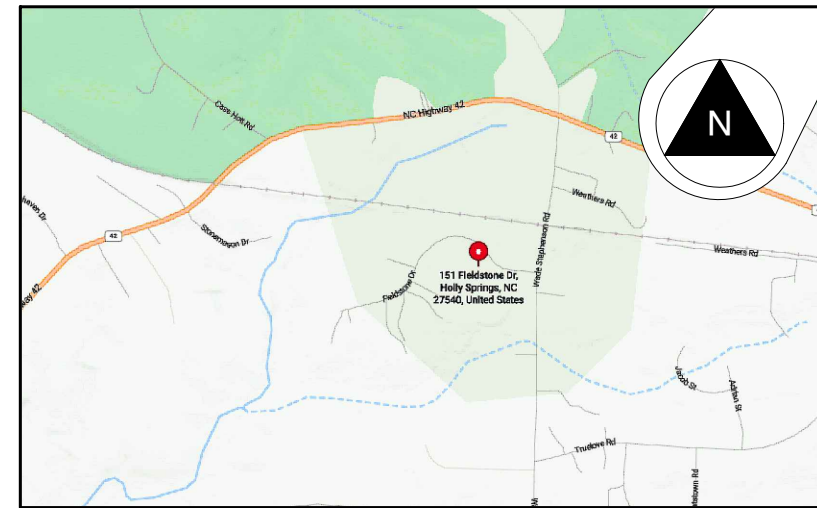

**CONTRACTOR INFORMATION**

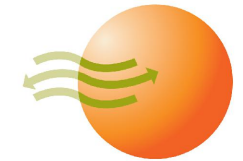

**SOUTHERN ENERGY  
MANAGEMENT**  
ENERGY EFFICIENCY & SOLAR POWER

**SOUTHERN ENERGY  
MANAGEMENT**  
5908 TRIANGLE DR, RALEIGH, NC  
27617  
PHONE: +1 984 220 0760

**PHOTOVOLTAIC ROOF  
MOUNT SYSTEM & ENERGY  
STORAGE SYSTEM**

8.505 kWDC, 11.500 kWAC PV  
**SYSTEM**  
13.500kWh **ENERGY STORAGE**  
JAMES SCHMADEKE RESIDENCE  
151 FIELDSTONE DR,  
HOLLY SPRINGS, NC 27540

**GENERAL NOTES**

1. MODULES ARE LISTED UNDER UL 61730 / UL 1703 AND CONFORM TO THE STANDARDS.
2. INVERTERS ARE LISTED UNDER UL 1741 AND CONFORM TO THE STANDARDS.
3. DRAWINGS ARE DIAGRAMMATIC, INDICATING GENERAL ARRANGEMENT OF THE PV SYSTEM AND THE ACTUAL SITE CONDITIONS MAY VARY.
4. WORKING CLEARANCES AROUND THE NEW PV ELECTRICAL EQUIPMENT SHALL BE MAINTAINED IN ACCORDANCE WITH NEC 110.26 .
5. ALL GROUND WIRING CONNECTED TO THE MAIN SERVICE GROUNDING IN MAIN SERVICE PANEL/ SERVICE EQUIPMENT.
6. ALL CONDUCTORS SHALL BE 600V, 90°C STANDARD COPPER UNLESS OTHERWISE NOTED.
7. WHEN REQUIRED, A LADDER SHALL BE IN PLACE FOR INSPECTION IN COMPLIANCE WITH OSHA REGULATIONS.
8. THE SYSTEM WILL NOT BE INTERCONNECTED BY THE CONTRACTOR UNTIL APPROVAL FROM THE UTILITY IS RECEIVED.
9. ROOF ACCESS POINT SHALL BE LOCATED IN AREAS THAT DO NOT REQUIRE THE PLACEMENT OF GROUND LADDERS OVER OPENINGS SUCH AS WINDOWS OR DOORS, AND LOCATED AT STRONG POINTS OF BUILDING CONSTRUCTION WHERE THE ACCESS POINT DOES NOT CONFLICT WITH OVERHEAD OBSTRUCTIONS SUCH AS TREES, WIRES OR SIGNS.
- 10.PV ARRAY COMBINER/JUNCTION BOX PROVIDES TRANSITION FROM ARRAY WIRING TO CONDUIT WIRING.
11. RACKING SYSTEM SHALL BE LISTED TO UL 2703.
- 12.FIRE RATING OF EXISTING ROOF ASSEMBLY SHALL BE MAINTAINED WITH ADDITION OF PHOTOVOLTAIC SYSTEM.

**SHEET INDEX**

- PV-1 COVER SHEET
- PV-2 SITE PLAN
- PV-3 PROPERTY PLAN
- PV-4 ROOF PLAN
- PV-5 ATTACHMENT DETAIL
- PV-6 SINGLE LINE DIAGRAM
- PV-7 ELECTRICAL CALC. AND NOTES
- PV-8 LABELS & PLACARD
- PV-9 TO PV-14 SPEC SHEETS



<b>DATE</b>	6/6/2024
<b>CREATED BY</b>	ART
<b>SCALE</b>	NTS

COVER SHEET

**PV-1**



# LEGEND

----- PROPERTY LINE

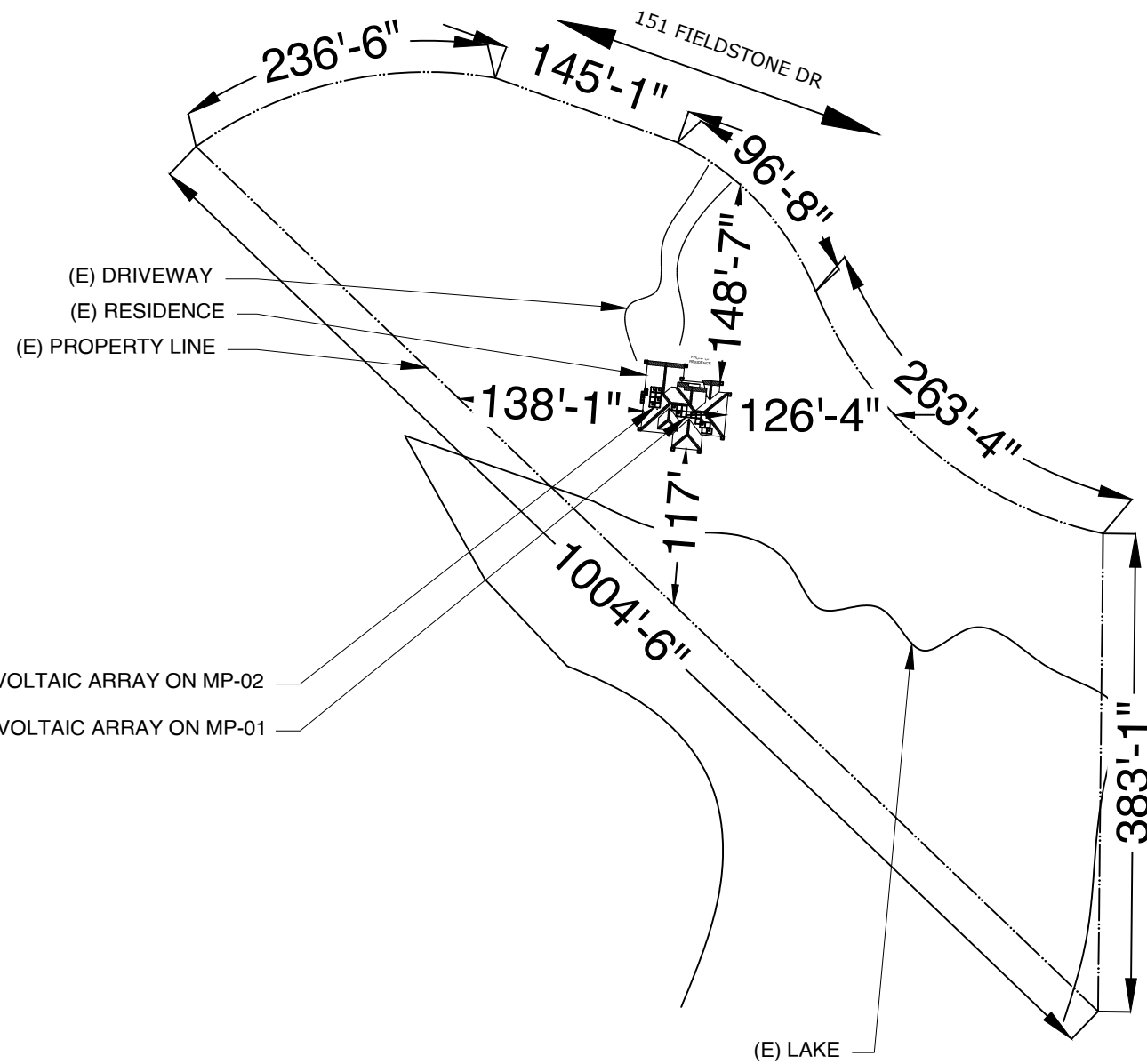

## CONTRACTOR INFORMATION

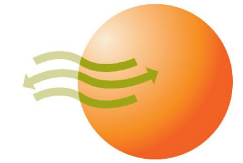

**SOUTHERN ENERGY**  
MANAGEMENT  
ENERGY EFFICIENCY & SOLAR POWER

**SOUTHERN ENERGY MANAGEMENT**  
5908 TRIANGLE DR, RALEIGH, NC 27617  
PHONE: +1 984 220 0760

### PHOTOVOLTAIC ROOF MOUNT SYSTEM & ENERGY STORAGE SYSTEM

8.505 kWDC, 11.500 kWAC PV SYSTEM  
13.500kWh ENERGY STORAGE  
JAMES SCHMADEKE RESIDENCE  
151 FIELDSTONE DR,  
HOLLY SPRINGS, NC 27540

DATE	6/6/2024
CREATED BY	ART
SCALE	1/128" = 1'-0"

PROPERTY PLAN

**PV-3**



**MODULE TYPE, DIMENSION & WEIGHT**

NUMBER OF MODULES = 21 MODULES  
 MODULE TYPE = ZNSHINESOLAR: ZXM7-SH108 405W MODULES  
 MODULE WEIGHT = 45.85 LBS / 20.5KG  
 MODULE DIMENSIONS = 67.79" X 44.64" = 21.01 SF

60 ATTACHMENTS INSTALLED @ 48" O.C. MAX (TYP)  
 NOTE: PENETRATIONS ARE STAGGERED.

ROOF DESCRIPTION						
ROOF LAYER		1 LAYER				
ROOF	# OF MODULES	ROOF PITCH	AZIMUTH	RAFTER SIZE	RAFTER SPACING	ROOF TYPE
1	13	42°	186°	2" X 8"	16"	COMPOSITION SHINGLES
2	8	45°	276°	2" X 8"	16"	COMPOSITION SHINGLES

ARRAY & ROOF AREA CALC'S		
TOTAL PV ARRAY AREA (Sq. Ft.)	TOTAL ROOF AREA (Sq. Ft.)	ROOF AREA COVERED BY ARRAY (%)
441.31	4280	10.3

**CONTRACTOR INFORMATION**

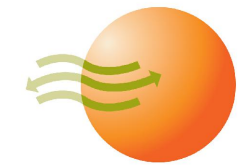

**SOUTHERN ENERGY MANAGEMENT**  
 ENERGY EFFICIENCY & SOLAR POWER

**SOUTHERN ENERGY MANAGEMENT**  
 5908 TRIANGLE DR, RALEIGH, NC 27617  
 PHONE: +1 984 220 0760

**PHOTOVOLTAIC ROOF MOUNT SYSTEM & ENERGY STORAGE SYSTEM**  
 8.505 kWDC, 11.500 kWAC PV SYSTEM  
 13.500kWh ENERGY STORAGE  
 JAMES SCHMADEKE RESIDENCE  
 151 FIELDSTONE DR, HOLLY SPRINGS, NC 27540

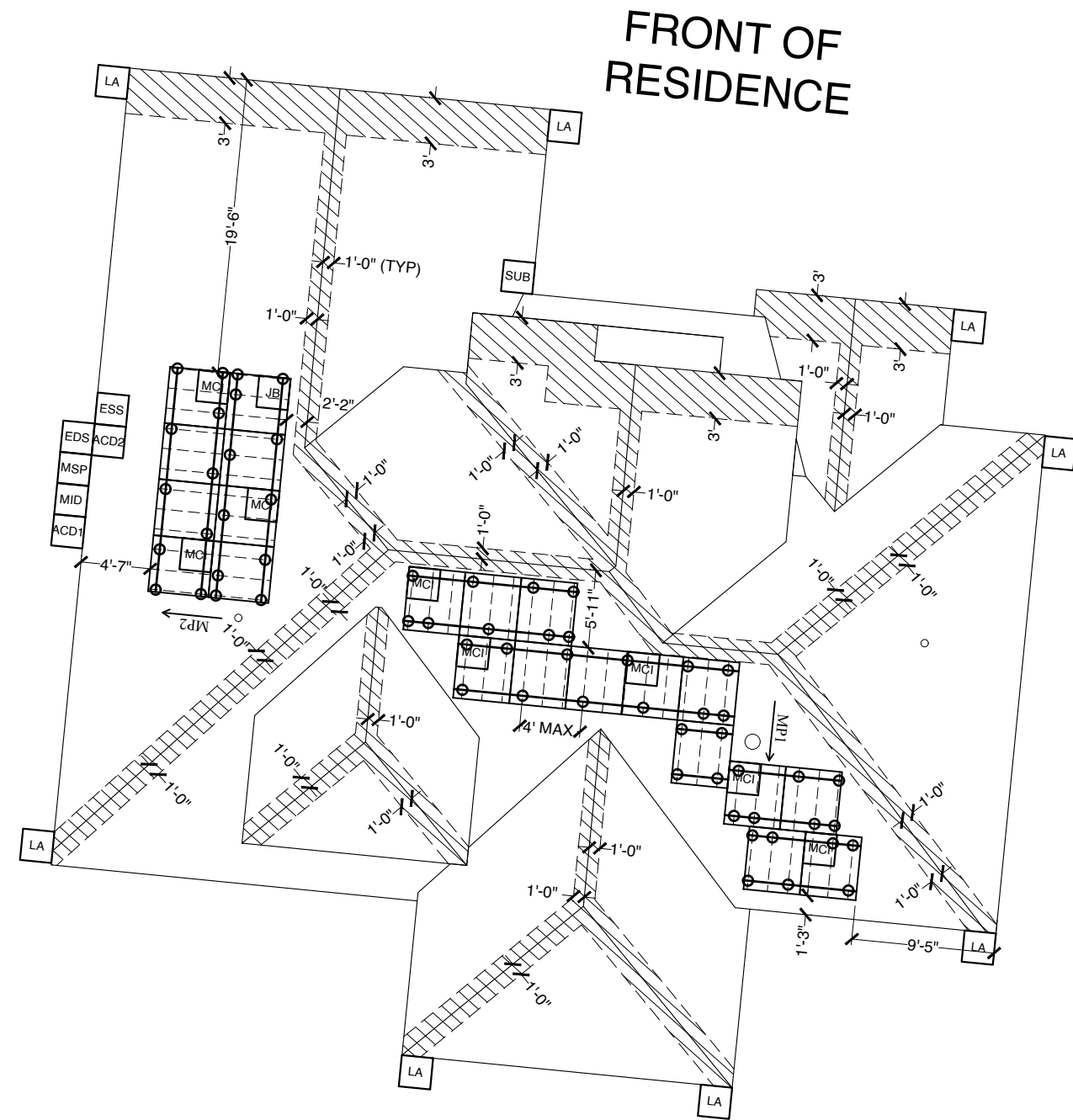
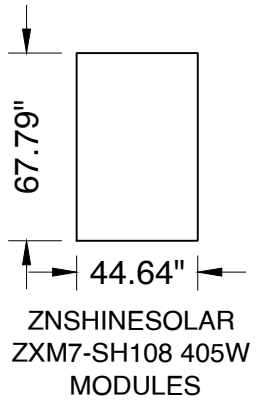

**LEGEND**

- MSP (E) UTILITY METER  
(E) 200A MAIN SERVICE PANEL (RULE OF SIX)
- SUB (E) 200A SUB PANEL  
(E) 200A MAIN BREAKER (WILL ACT AS A BACKUP LOAD CENTER)
- ESS (N) TESLA POWERWALL 3 BATTERY  
EQUIPPED WITH INTEGRATED INVERTER
- MID (N) 200A TESLA BACKUP GATEWAY 2  
MICRO-GRID INTERCONNECTION DEVICE 240V NEMA-3R
- ACD1 (N) 60A NON FUSED AC DISCONNECT 1  
VISIBLELY OPEN, LOCKABLE 240V NEMA-3R
- LA LADDER ACCESS
- ACD2 (N) 60A FUSED AC DISCONNECT 2  
VISIBLELY OPEN, LOCKABLE 240V NEMA-3R
- EDS (N) ESS DISCONNECT SWITCH
- MCI (N) 8 MID-CIRCUIT INTERRUPTER
- JB (N) JUNCTION BOX 240V, NEMA 4X (ON ROOF)
- [Module Symbol] (N) 21 ZNSHINESOLAR ZXM7-SH108 405W SOLAR MODULES
- [Hatched Box] FIRE SETBACKS
- (E) ROOF OBSTRUCTIONS
- (N) ROOF ATTACHMENTS
- (E) RAFTER
- ===== (N) RAIL



<b>DATE</b>	6/6/2024
<b>CREATED BY</b>	ART
<b>SCALE</b>	3/32" = 1'-0"

ROOF PLAN

**PV-4**



**CONTRACTOR INFORMATION**

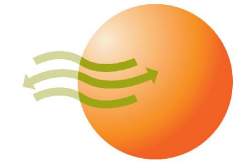

**SOUTHERN ENERGY  
MANAGEMENT**  
ENERGY EFFICIENCY & SOLAR POWER

**SOUTHERN ENERGY  
MANAGEMENT**  
5908 TRIANGLE DR, RALEIGH, NC  
27617  
PHONE: +1 984 220 0760

**PHOTOVOLTAIC ROOF  
MOUNT SYSTEM & ENERGY  
STORAGE SYSTEM**

8.505 kWDC, 11.500 kWAC PV  
**SYSTEM**  
13.500kWh **ENERGY STORAGE**  
JAMES SCHMADEKE RESIDENCE  
151 FIELDSTONE DR,  
HOLLY SPRINGS, NC 27540

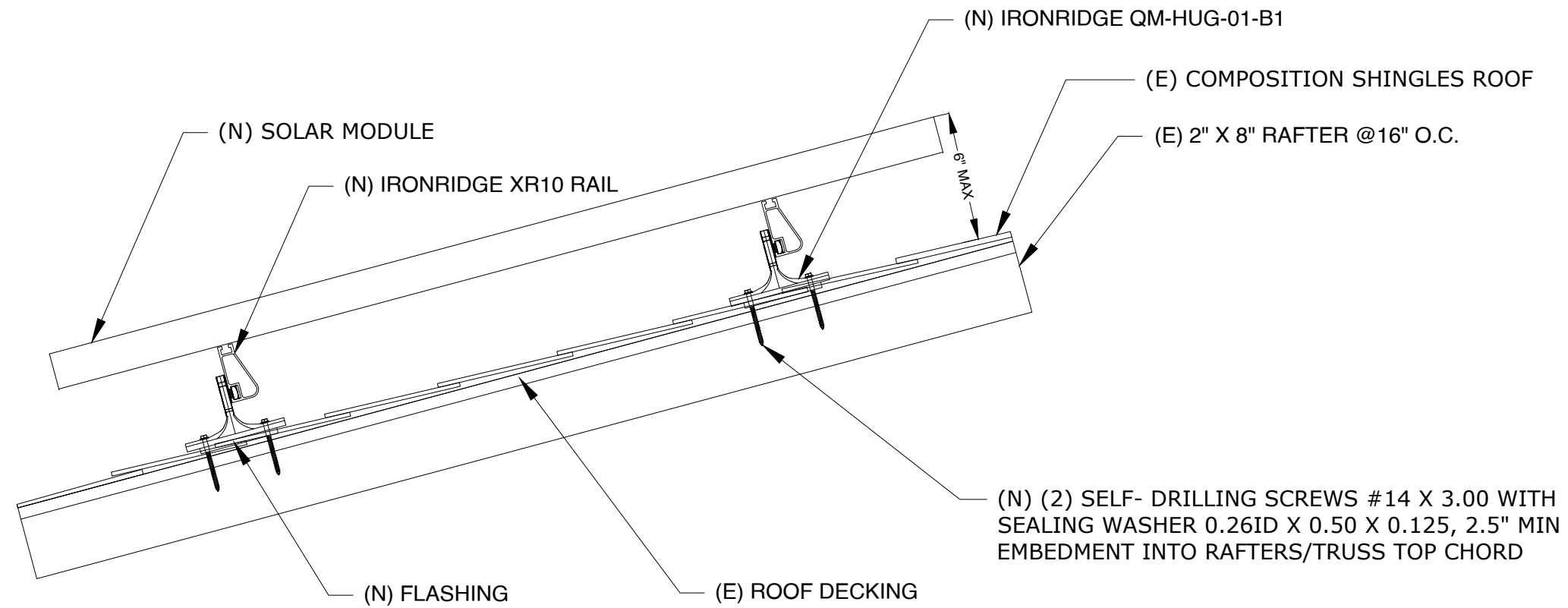

ATTACHMENT DETAIL:  
SCALE: NTS

<b>DATE</b>	6/6/2024
-------------	----------

<b>CREATED BY</b>	ART
-------------------	-----

<b>SCALE</b>	NTS
--------------	-----

ATTACHMENT DETAIL

**PV-5**

DC SYSTEM SIZE: 8.505kW DC  
 AC SYSTEM SIZE: 11.500kW AC  
 ENERGY STORAGE SYSTEM SIZE: 13.500kWh

(21) ZNSHINESOLAR: ZXM7-SH108 405W MODULES  
 (8) MID-CIRCUIT INTERRUPTER  
 (1) TESLA POWERWALL 3 BATTERY WITH INTERGRATED INVERTER EQUIPPED WITH RAPID SHUTDOWN

**STRINGS**

(1) STRING CIRCUIT OF 8 MODULES CONNECTED IN SERIES  
 (1) STRING CIRCUIT OF 7 MODULES CONNECTED IN SERIES  
 (1) STRING CIRCUIT OF 6 MODULES CONNECTED IN SERIES

INVERTER SPEC			
MODEL:	TESLA POWERWALL 3 BATTERY WITH INTERGRATED INVERTER EQUIPPED WITH RAPID SHUTDOWN		
MAX O/P VOLTAGE:	240V		
MAX O/P CURRENT:	48A		
POWER RATING:	11500W		
CEC EFF:	97.5%	QTY.	1

MODULE SPEC	
MODEL:	ZXM7-SH108 405W
QTY:	21
WATT. :	405
Voc:	37.30
Isc:	13.77
Vmp:	31.10
Imp:	13.03

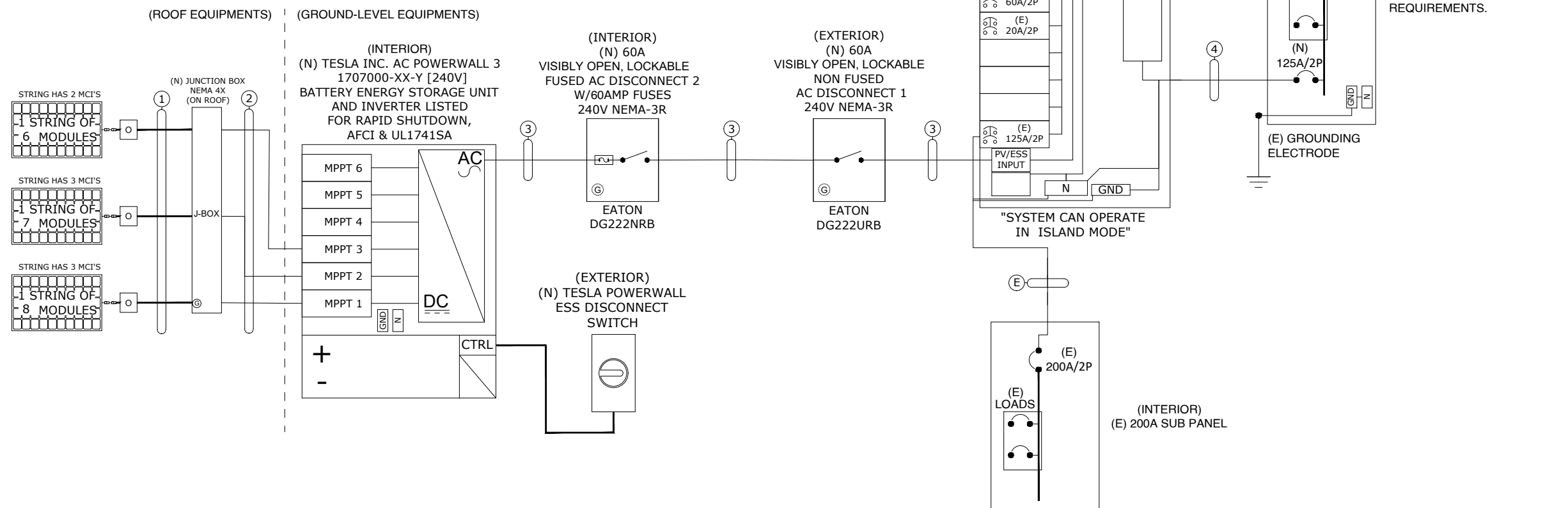

UTILITY:  
 DUKE ENERGY CAROLINAS, LLC  
 METER:  
 328 427 194

THE DESIGNED INTERCONNECTION MEETS THE 705.12(A) REQUIREMENTS.

CONDUCTOR SCHEDULE				
TAG ID	CONDUIT SIZE	CONDUCTOR	NEUTRAL	GROUND
1	OPEN AIR	(6) 10 AWG PV WIRE	NONE	(1) 6 AWG BARE COPPER, EGC
2	3/4"EMT	(6) 10 AWG THHN/THWN-2, Cu	NONE	(1) 10 AWG THHN/THWN-2, EGC
3	1" EMT	(2) 4 AWG THHN/THWN-2, Cu	(1) 4 AWG THHN/THWN-2, Cu	(1) 8 AWG THHN/THWN-2, EGC
4	1-1/2"EMT	(2) 1/0 AWG THHN/THWN-2, Cu	(1) 1/0 AWG THHN/THWN-2, Cu	(1) 6 AWG THHN/THWN-2, EGC
E	EXISTING	EXISTING	EXISTING	EXISTING

**CONTRACTOR INFORMATION**



**SOUTHERN ENERGY MANAGEMENT**  
 5908 TRIANGLE DR, RALEIGH, NC 27617  
 PHONE: +1 984 220 0760

**PHOTOVOLTAIC ROOF MOUNT SYSTEM & ENERGY STORAGE SYSTEM**

8.505 kWDC, 11.500 kWAC PV SYSTEM  
 13.500kWh ENERGY STORAGE  
 JAMES SCHMADEKE RESIDENCE  
 151 FIELDSTONE DR, HOLLY SPRINGS, NC 27540

DATE	6/6/2024
CREATED BY	ART
SCALE	NTS

SINGLE LINE DIAGRAM

**PV-6**

## FOR TESLA WITH INTEGRATED INVERTER

MAX BRANCH DC REQUIRED CONDUCTOR AMPACITY  
(19)(1.25) = 23.75A

AWG #10, DERATED AMPACITY:  
(40)x(0.91)x(0.8) = 29.12A

FROM TABLE 310.15(B)(16),90°C COLUMN

**29.12A>23.75A , THEREFORE DC WIRE SIZE IS VALID**

COMBINED SYSTEM AC REQUIRED CONDUCTOR AMPACITY  
(1)(48)(1.25) = 60.00A PER NEC §690.8(A)

AWG #4, DERATED AMPACITY:  
(85)x(0.88)x(1) = 74.80A

FROM TABLE 310.15(B)(16),75°C COLUMN

**74.80A>60.00A , THEREFORE AC WIRE SIZE IS VALID**

NOTE: CONDUIT SHALL BE INSTALLED MIN 7/8" ABOVE  
ROOF SURFACE

## OCPD CALCULATION

### ALLOWABLE BACKFEED:

MAIN SERVICE PANEL RATING = 200A  
MAIN BREAKER RATING = 200A

### INVERTER OVERCURRENT PROTECTION:

INVERTER OVERCURRENT PROTECTION = INVERTER O/P CURRENT \*  
CONTINUOUS LOAD(1.25)  
= 48.00 \* 1.25  
= 60.00 A  
PV OVERCURRENT PROTECTION = 60A

**THE DESIGNED INTERCONNECTION MEETS THE NEC 705.12(A) REQUIREMENTS.**

ASHRAE 2021 -  
HIGHEST MONTHLY 2% D.B. DESIGN TEMP.: 35.2°C  
LOWEST MIN. MEAN EXTREME D.B.: -12.1°C

### INTERCONNECTION NOTES:

1. INTERCONNECTION SIZING, LIMITATIONS AND COMPLIANCE DETERMINED IN ACCORDANCE WITH [NEC 705.12], AND [NEC 690.64].
2. GROUND FAULT PROTECTION IN ACCORDANCE WITH [NEC 215.9], [NEC 230.95] AND [NEC 690.5]
3. ALL EQUIPMENT TO BE RATED FOR BACKFEEDING.
4. PV BREAKER TO BE POSITIONED AT THE OPPOSITE END OF THE BUSBAR RELATIVE TO THE MAIN BREAKER.

### DISCONNECT NOTES:

1. DISCONNECTING SWITCHES SHALL BE WIRED SUCH THAT WHEN THE SWITCH IS OPENED THE CONDUCTORS REMAINING LIVE ARE CONNECTED TO THE TERMINALS MARKED "LINE SIDE" (TYPICALLY THE UPPER TERMINALS)
2. AC DISCONNECT MUST BE ACCESSIBLE TO QUALIFIED UTILITY PERSONNEL, BE LOCKABLE, AND BE A VISIBLE-BREAK SWITCH

### RACKING NOTE:

1. BOND AND GROUND RACKING AND MODULES IN ACCORDANCE WITH THE MANUFACTURER'S INSTALLATION INSTRUCTIONS. MINIMUM ONE CONNECTION PER ARRAY

### GROUNDING & GENERAL NOTES:

1. A SECOND FACILITY GROUNDING ELECTRODE IS NOT REQUIRED PER [NEC 690.47(C)(3)]
2. PV INVERTER IS UNGROUNDED, TRANSFORMER-LESS TYPE.
3. DC GEC AND AC EGC TO REMAIN UNSPLICED, OR SPLICED TO EXISTING ELECTRODE
4. ANY EXISTING WIRING INVOLVED WITH PV SYSTEM CONNECTION THAT IS FOUND TO BE INADEQUATE PER CODE SHALL BE CORRECTED PRIOR TO FINAL INSPECTION.
5. SOLADECK OR JUNCTION BOX QUANTITIES, AND PLACEMENT SUBJECT TO CHANGE IN THE FIELD - SOLADECK OR JUNCTION BOX DEPICTED ON ELECTRICAL DIAGRAM REPRESENT WIRE TYPE TRANSITIONS.
6. AC DISCONNECT NOTED IN EQUIPMENT SCHEDULE OPTIONAL IF OTHER AC DISCONNECTING MEANS IS LOCATED WITHIN 10' OF SERVICE DISCONNECT
7. RACEWAYS AND CABLES EXPOSED TO SUNLIGHT ON ROOFTOPS SHOULD BE INSTALLED MORE THAN 7/8" ABOVE THE ROOF USING CONDUIT SUPPORTS.
8. TEMPERATURE RATINGS OF ALL CONDUCTORS, TERMINATIONS, BREAKERS, OR OTHER DEVICES ASSOCIATED WITH THE SOLAR PV SYSTEM SHALL BE RATED FOR AT LEAST 75 DEGREE C.
9. WIRE IS SIZED PER NEC 310.15(B)(16), 310.15(B)(2)(a) and NEC 310.15(B)(3)(a)
10. ALL ROOF CONDUIT WILL HAVE A HEIGHT OF 7/8"

## CONTRACTOR INFORMATION



### SOUTHERN ENERGY MANAGEMENT

5908 TRIANGLE DR, RALEIGH, NC  
27617  
PHONE: +1 984 220 0760

### PHOTOVOLTAIC ROOF MOUNT SYSTEM & ENERGY STORAGE SYSTEM

8.505 kWDC, 11.500 kWAC PV  
SYSTEM  
13.500kWh ENERGY STORAGE  
JAMES SCHMADEKE RESIDENCE  
151 FIELDSTONE DR,  
HOLLY SPRINGS, NC 27540

DATE 6/6/2024

CREATED BY ART

SCALE NTS

ELECTRICAL CALC. AND NOTES

**PV-7**

**WARNING:PHOTOVOLTAIC  
POWER SOURCE**

**LABEL 1**  
AT DIRECT-CURRENT EXPOSED RACEWAYS, CABLE TRAYS,  
COVERS AND ENCLOSURES OF JUNCTION BOXES, AND  
OTHER WIRING METHODS; SPACED AT MAXIMUM 10FT  
SECTION OR WHERE SEPARATED BY ENCLOSURES,  
WALLS, PARTITIONS, CEILINGS, OR FLOORS.  
NEC 690.31(G)(3&4)

**PHOTOVOLTAIC**

**DC DISCONNECT**

**LABEL 2**  
AT EACH PV DISCONNECTING MEANS  
NEC 690.13(B)

MAXIMUM VOLTAGE   
MAXIMUM CIRCUIT CURRENT   
MAX RATED OUTPUT CURRENT OF  
THE CHARGE CONTROLLER  
OR DC-TO-DC CONVERTER  
(IF INSTALLED)

**LABEL 3 (FOR TESLA POWERWALL 3  
WITH INTEGRATED INVERTER)**  
AT DC PV SYSTEM DISCONNECTING  
MEANS NEC 690.53

**PHOTOVOLTAIC**

**AC DISCONNECT**

**LABEL 4**  
AT AC DISCONNECT  
MEANS NEC 690.13(B)

**LABEL 5 (FOR TESLA POWERWALL  
3 WITH INTEGRATED INVERTER)**  
AT AC DISCONNECTING MEANS  
NEC 690.54

**PHOTOVOLTAIC AC DISCONNECT**  
RATED AC OUTPUT CURRENT:   
NOMINAL OPERATING AC VOLTAGE:

1 INVERTER X 48 AMP/INVERTER = 48.00AMP

**LABEL 9**  
AT AC DISCONNECT NEC 690.56(C)(3)

**RAPID SHUTDOWN  
SWITCH FOR SOLAR  
PV SYSTEM**

**WARNING**  
INVERTER OUTPUT CONNECTION  
DO NOT RELOCATE  
THIS OVERCURRENT  
DEVICE

**LABEL 6**  
PLACED ADJACENT TO THE BACK-FED  
BREAKER FROM THE INVERTER IF TIE IN  
CONSISTS OF LOAD SIDE CONNECTION  
TO BUSBAR. NEC 705.12(B)(2)(3)(b)

**WARNING: THREE POWER SOURCE**  
SECOND SOURCE IS PHOTOVOLTAIC SYSTEM  
THIRD SOURCE IS ENERGY STORAGE SYSTEM

**ENERGY STORAGE SYSTEM**

NOMINAL ESS VOLTAGE: 240 VAC  
OPERATING CURRENT: 48.00 AAC

LABEL FOR ESS BATTERY ,  
QTY-1

**PHOTOVOLTAIC POWER SOURCE**

OPERATING AC VOLTAGE: 240 V  
MAXIMUM OPERATING AC OUTPUT  
CURRENT: 48.00 AMPS

LABEL FOR MAIN SERVICE PANEL COVER

THIS IS THE  
COMBINED  
AMPERAGE OF  
INVERTER AND  
BATTERY

**SOLAR PV SYSTEM EQUIPPED  
WITH RAPID SHUTDOWN**

TURN RAPID SHUTDOWN  
SWITCH TO THE  
"OFF" POSITION TO  
SHUT DOWN PV SYSTEM  
AND REDUCE  
SHOCK HAZARD  
IN THE ARRAY

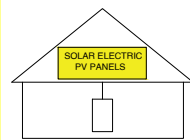

**CAUTION**

POWER TO THIS BUILDING IS ALSO SUPPLIED FROM  
MULTIPLE SOURCES OF POWER WITH SAFETY  
DISCONNECTS AS SHOWN:

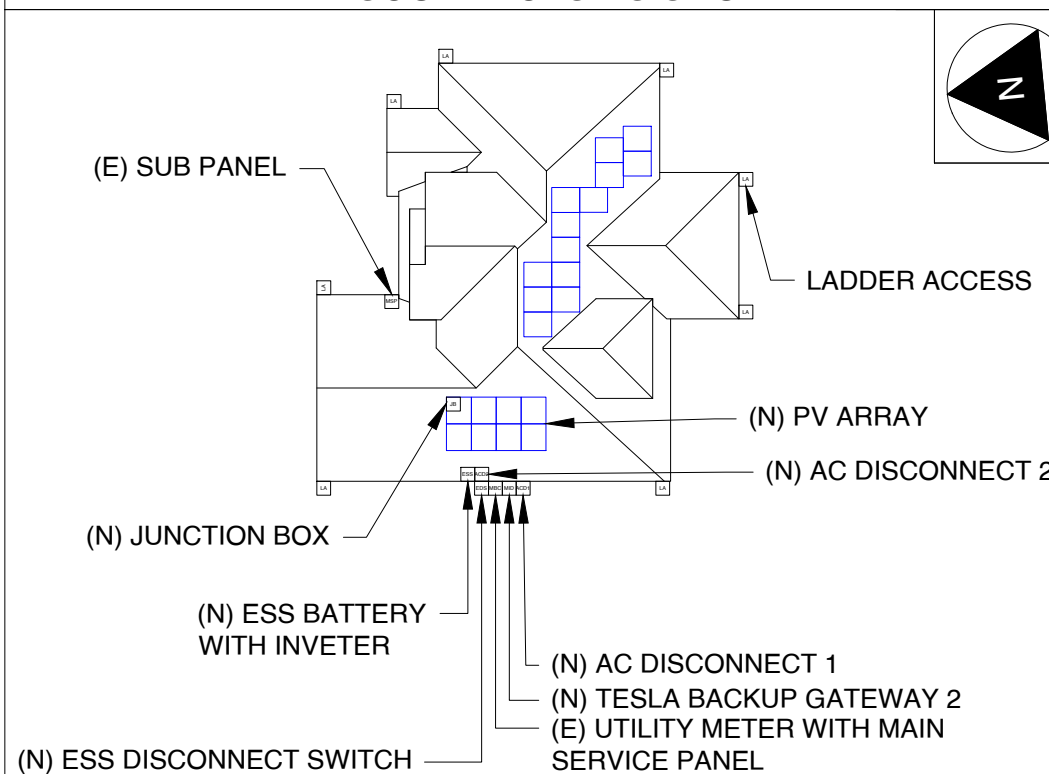

151 FIELDSTONE DR, HOLLY SPRINGS, NC 27540

**DIRECTORY**  
PERMANENT PLAQUE OR DIRECTORY PROVIDING THE LOCATION OF THE  
SERVICE DISCONNECTING MEANS AND THE PHOTOVOLTAIC SYSTEM. (ALL  
PLAQUES AND SIGNAGE WILL BE INSTALLED AS OUTLINED WITHIN: NEC  
690.56(B)&(C), [NEC 705.10])

**LABEL 8**  
FOR PV SYSTEMS THAT SHUT DOWN THE ARRAY AND CONDUCTORS  
LEAVING THE ARRAY: SIGN TO BE LOCATED ON OR NO MORE THAN 3  
FT AWAY FROM SERVICE DISCONNECTING MEANS TO WHICH THE PV  
SYSTEMS ARE CONNECTED AND SHALL INDICATE THE LOCATION OF  
ALL IDENTIFIED RAPID SHUTDOWN SWITCHES IF NOT AT THE SAME  
LOCATION. [NEC 690.56(C)(1)(A)]

**CONTRACTOR INFORMATION**

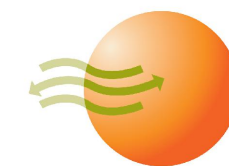

**SOUTHERN ENERGY  
MANAGEMENT**  
ENERGY EFFICIENCY & SOLAR POWER

**SOUTHERN ENERGY  
MANAGEMENT**  
5908 TRIANGLE DR, RALEIGH, NC  
27617  
PHONE: +1 984 220 0760

**PHOTOVOLTAIC ROOF  
MOUNT SYSTEM & ENERGY  
STORAGE SYSTEM**

8.505 kWDC, 11.500 kWAC PV  
SYSTEM  
13.500kWh ENERGY STORAGE  
JAMES SCHMADEKE RESIDENCE  
151 FIELDSTONE DR,  
HOLLY SPRINGS, NC 27540

<b>DATE</b>	6/6/2024
<b>CREATED BY</b>	ART
<b>SCALE</b>	NTS

LABELS AND PLACARD

**PV-8**





# ZXM7-SH108 Series

10BB HALF-CELL Black Monocrystalline PERC PV Module

**390-410W** POWER RANGE    **21.00%** MAXIMUM EFFICIENCY    **0.55%** YEARLY DEGRADATION

**12 YEARS PRODUCT WARRANTY**    **25 YEARS OUTPUT GUARANTEE**



IEC 61215/IEC 61730/IEC 61701/IEC 62716/UL6 1730

ISO 14001: Environmental Management System

ISO 9001: Quality Management System

ISO45001: Occupational Health and Safety Management System

\*As there are different certification requirements in different markets, please contact your local znshine sales representative for the specific certificates applicable to the products in the region in which the products are to be used.

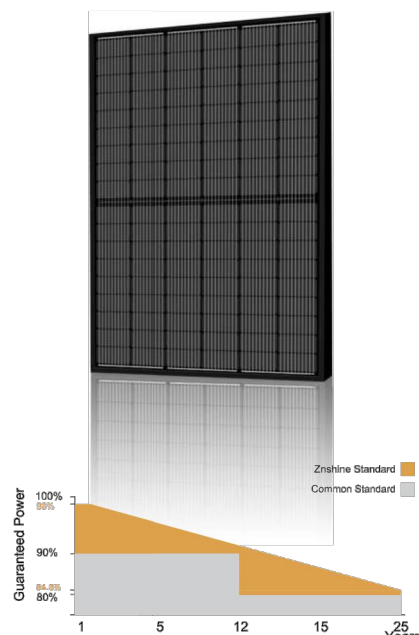

\*Please check the valid version of Limited Product Warranty which is officially released by ZNSHINE PV-TECH Co., Ltd.

## KEY FEATURES

- Excellent Cells Efficiency**  
MBB technology reduce the distance between busbars and finger grid line which is benefit to power increase.
- Anti PID**  
Ensured PID resistance through the quality control of cell manufacturing process and raw materials.
- TIER 1**  
Global, Tier 1 bankable brand, with independently certified advanced automated manufacturing.
- Improved Aesthetics**  
Compared to conventional modules, this full black modules have a more uniform appearance and superior aesthetics.

- Better Weak Illumination Response**  
More power output in weak light condition, such as haze, cloudy, and early morning.
- Adapt To Harsh Outdoor Environment**  
Resistant to harsh environments such as salt, ammonia, sand, high temperature and high humidity environment.
- Excellent Quality Management System**  
Warranted reliability and stringent quality assurances well beyond certified requirements.

ZXM7-SH108 Series | Znshinesolar 10BB HALF-CELL Black Monocrystalline PERC PV Module



### DIMENSIONS OF PV MODULE(mm)

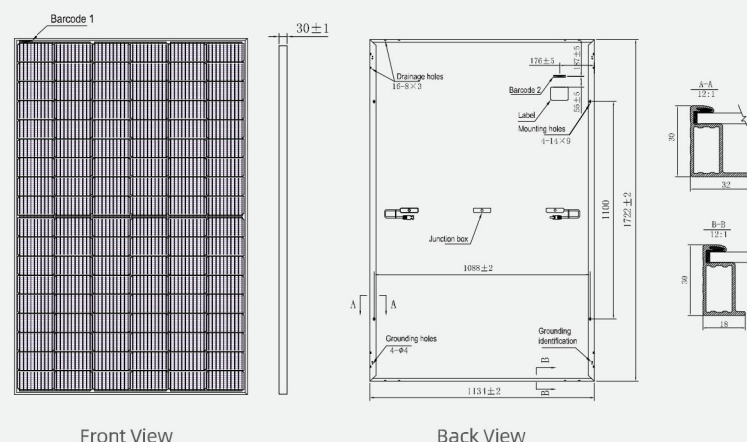

\*Remark: customized frame color and cable length available upon request

### I-V CURVES OF PV MODULE(400W)

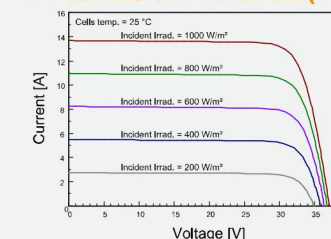

### P-V CURVES OF PV MODULE(400W)

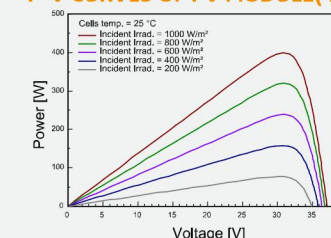

### ELECTRICAL CHARACTERISTICS | STC\*

Nominal Power Watt Pmax(W)*	390	395	400	405	410
Maximum Power Voltage Vmp(V)	30.50	30.70	30.90	31.10	31.30
Maximum Power Current Imp(A)	12.79	12.87	12.95	13.03	13.10
Open Circuit Voltage Voc(V)	36.70	36.90	37.10	37.30	37.50
Short Circuit Current Isc(A)	13.56	13.63	13.70	13.77	13.84
Module Efficiency (%)	19.97	20.23	20.48	20.74	21.00

\*The data above is for reference only and the actual data is in accordance with the practical testing.  
\*STC (Standard Test Condition): Irradiance 1000W/m², Module Temperature 25±2°C, AM 1.5  
\*Measuring uncertainty: ±3%, all the electrical characteristics such as Power, Im, Vm and FF are within ±3% tolerance.

### ELECTRICAL CHARACTERISTICS | NMOT

Maximum Power Pmax(Wp)	291.50	295.20	299.00	302.70	306.30
Maximum Power Voltage Vmpp(V)	28.30	28.50	28.70	28.90	29.10
Maximum Power Current Imp(A)	10.29	10.35	10.41	10.47	10.53
Open Circuit Voltage Voc(V)	34.30	34.50	34.70	34.80	35.00
Short Circuit Current Isc(A)	10.95	11.01	11.06	11.12	11.18

\*NMOT: Irradiance 800W/m², Ambient Temperature 20°C, AM 1.5, Wind Speed 1m/s

### PACKAGING CONFIGURATION\*

Piece/Box	36
Piece/Container(40'HQ)	936

\*Customized packaging is available upon request.

### MECHANICAL DATA

Solar cells	Mono PERC
Cells orientation	108 (6x18)
Module dimension	1722x1134x30 mm (With Frame)
Weight	20.5±1.0 kg
Glass	3.2mm, High Transmission, AR Coated Tempered Glass
Junction box	IP 68, 3 diodes
Cables	4 mm², 350 mm (With Connectors)
Connectors*	MC4-compatible

\*Please refer to regional datasheet for specified connector

### TEMPERATURE RATINGS\*

NMOT	44°C ±2°C	Maximum system voltage	1500 V DC
Temperature coefficient of Pmax	-0.35%/°C	Operating temperature	-40°C~+85°C
Temperature coefficient of Voc	-0.29%/°C	Maximum series fuse	25 A
Temperature coefficient of Isc	0.05%/°C	Front Side Maximum Static Loading	Up to 5400 Pa

Rear Side Maximum Static Loading Up to 2400 Pa

\*Remark: Do not connect Fuse in Combiner Box with two or more strings in parallel connection.  
\*Remark: Electrical data in this catalog do not refer to a single module and they are not part of the offer.  
\*They only serve for comparison among different module types.  
\*Caution: Please be kindly advised that PV modules should be handled and installed by qualified people who have professional skills and please carefully read the safety and installation instructions before using our PV modules.

Founded in 1988, ZNSHINE solar is a world's leading high-tech PV module manufacturer. With the advanced production lines, the company boasts module capacity of 6GW. Bloomberg has listed ZNSHINE as a global Tier 1 PV module maker. Today ZNSHINE has distributed its sales to more than 60 countries around the globe.

www.znshinesolar.com

Add : 1#, Zhixi Industrial Zone, Jintan Jiangsu 213251, P.R. China    Tel: +86 519 6622 0233    E-mail: info@znshinesolar.com

Note: Specifications included in this datasheet are subject to change without notice. ZNSHINE reserves the right of final interpretation © ZNSHINE SOLAR 2022 | Version: ZXM7-SH108 2203.E  
No special undertaking or warranty for the suitability of special purpose or being installed in extraordinary surroundings is granted unless as otherwise specifically committed by manufacturer in contract document

## CONTRACTOR INFORMATION



SOUTHERN ENERGY  
MANAGEMENT  
ENERGY EFFICIENCY & SOLAR POWER

**SOUTHERN ENERGY MANAGEMENT**  
5908 TRIANGLE DR, RALEIGH, NC 27617  
PHONE: +1 984 220 0760

## PHOTOVOLTAIC ROOF MOUNT SYSTEM & ENERGY STORAGE SYSTEM

8.505 kWDC, 11.500 kWAC PV SYSTEM  
13.500kWh ENERGY STORAGE  
JAMES SCHMADEKE RESIDENCE  
151 FIELDSTONE DR,  
HOLLY SPRINGS, NC 27540

DATE 6/6/2024

CREATED BY ART

SCALE NTS

MODULE SPEC SHEET

PV-9

## Powerwall 3

### Power Everything

Powerwall 3 is a fully integrated solar and battery system, designed to accelerate the transition to sustainable energy. Customers can receive whole home backup, cost savings, and energy independence by producing and consuming their own energy while participating in grid services. Once installed, customers can manage their system using the Tesla App to customize system behavior to meet their energy goals.

Powerwall 3 achieves this by supporting up to 20 kW DC of solar and providing 11.5 kW AC of continuous power per unit. It has the ability to start heavy loads up to 185 A LRA, meaning a single unit can support the power needs of most homes. Powerwall 3 is designed for mass production, fast and efficient installations, easy system expansion, and simple connection to any electrical service.



## Powerwall 3 Technical Specifications

### System Technical Specifications

Model Number	1707000-xx-y
Nominal Grid Voltage (Input & Output)	120/240 VAC
Grid Type	Split phase
Frequency	60 Hz
Overcurrent Protection Device	Configurable up to 60 A
Solar to Battery to Home/Grid Efficiency	89% <sup>1,2</sup>
Solar to Home/Grid Efficiency	97.5% <sup>3</sup>
Supported Islanding Devices	Backup Gateway 2, Backup Switch
Connectivity	Wi-Fi (2.4 and 5 GHz), Dual-port switched Ethernet, Cellular (LTE/4G <sup>4</sup> )
Hardware Interface	Dry contact relay, Rapid Shutdown (RSD) certified switch and 2-pin connector, RS-485 for meters
AC Metering	Revenue Grade (+/- 0.5%)
Protections	Integrated arc fault circuit interrupter (AFCI), Isolation Monitor Interrupter (IMI), PV Rapid Shutdown (RSD) using Tesla Mid-Circuit Interrupters
Customer Interface	Tesla Mobile App
Warranty	10 years

### Solar Technical Specifications

Maximum Solar STC Input	20 kW
Withstand Voltage	600 V DC
PV DC Input Voltage Range	60 – 550 V DC
PV DC MPPT Voltage Range	150 – 480 V DC
MPPTs	6
Maximum Current per MPPT ( $I_{mp}$ )	13 A <sup>5</sup>
Maximum Short Circuit Current per MPPT ( $I_{sc}$ )	15 A <sup>5</sup>

### Battery Technical Specifications

Nominal Battery Energy	13.5 kWh AC <sup>2</sup>
Maximum Continuous Discharge Power	11.5 kW AC
Maximum Continuous Charge Power	5 kW AC
Output Power Factor Rating	0 - 1 (Grid Code configurable)
Maximum Continuous Current	48 A
Maximum Output Fault Current	10 kA
Load Start Capability (1 s)	185 A LRA
Power Scalability	Up to 4 Powerwall 3 units supported

<sup>1</sup>Typical solar shifting use case.

<sup>2</sup>Values provided for 25°C (77°F), at beginning of life. 3.3 kW charge/discharge power.

<sup>3</sup>Tested using CEC weighted efficiency methodology.

<sup>4</sup>Cellular connectivity subject to network service coverage and signal strength.

<sup>5</sup> Where the DC input current exceeds the MPPT rating, a jumper can be used to combine two MPPTs into a single input to intake DC current up to 26 A  $I_{mp}$  / 30 A  $I_{sc}$ .

## CONTRACTOR INFORMATION

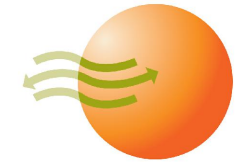

**SOUTHERN ENERGY  
MANAGEMENT**  
ENERGY EFFICIENCY & SOLAR POWER

### SOUTHERN ENERGY MANAGEMENT

5908 TRIANGLE DR, RALEIGH, NC  
27617

PHONE: +1 984 220 0760

### PHOTOVOLTAIC ROOF MOUNT SYSTEM & ENERGY STORAGE SYSTEM

8.505 kWDC, 11.500 kWAC PV  
SYSTEM

13.500kWh ENERGY STORAGE  
JAMES SCHMADEKE RESIDENCE  
151 FIELDSTONE DR,  
HOLLY SPRINGS, NC 27540

DATE	6/6/2024
------	----------

CREATED BY	ART
------------	-----

SCALE	NTS
-------	-----

INVERTER & BATTERY SPEC SHEET

## PV-10

## Powerwall 3 Technical Specifications

Environmental Specifications	Operating Temperature	-20°C to 50°C (-4°F to 122°F) <sup>6</sup>
	Operating Humidity (RH)	Up to 100%, condensing
	Storage Temperature	-20°C to 30°C (-4°F to 86°F), up to 95% RH, non-condensing, State of Energy (SOE): 25% initial
	Maximum Elevation	3000 m (9843 ft)
	Environment	Indoor and outdoor rated
	Enclosure Rating	NEMA 3R
	Ingress Rating	IPX7 (Battery & Power Electronics) IPX5 (Wiring Compartment)
	Pollution Rating	PD3
	Operating Noise @ 1 m	<50 db(A) typical <62 db(A) maximum

<sup>6</sup> Performance may be de-rated at operating temperatures above 40°C (104°F).

Compliance Information	Certifications	UL 1642, UL 1699B, UL 1741, UL 1741 SA, UL 1741 SB, UL 3741, UL 1973, UL 1998, UL 9540, IEEE 1547-2018, IEEE 1547.1, UN 38.3
	Grid Connection	United States
	Emissions	FCC Part 15 Class B
	Environmental	RoHS Directive 2011/65/EU
	Seismic	AC156, IEEE 693-2005 (high)
	Fire Testing	Meets the unit level performance criteria of UL 9540A

Mechanical Specifications	Dimensions	1099 x 609 x 193 mm (43.25 x 24 x 7.6 in)
	Weight	130 kg (287 lb)
	Mounting Options	Floor or wall mount

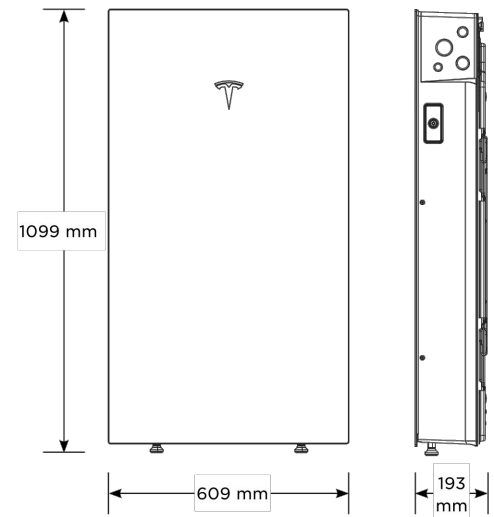

## Solar Shutdown Device Technical Specifications

The Solar Shutdown Device is a Mid-Circuit Interrupter (MCI) and is part of the PV system rapid shutdown (RSD) function in accordance with Article 690 of the applicable NEC. When paired with Powerwall 3, solar array shutdown is initiated by any loss of AC power.

Electrical Specifications	Model	MCI-1	MCI-2
	Nominal Input DC Current Rating ( $I_{MP}$ )	12 A	13 A
	Maximum Input Short Circuit Current ( $I_{SC}$ )	19 A	17 A
	Maximum System Voltage (PVHCS)	600 V DC	1000 V DC <sup>7</sup>
<sup>7</sup> Maximum System Voltage is limited by Powerwall to 600 V DC.			
RSD Module Performance	Maximum Number of Devices per String	5	5
	Control	Power Line Excitation	Power Line Excitation
	Passive State	Normally Open	Normally Open
	Maximum Power Consumption	7 W	7 W
	Warranty	25 years	25 years

Environmental Specifications	Operating Temperature	-40°C to 50°C (-40°F to 122°F)	-45°C to 70°C (-49°F to 158°F)
	Storage Temperature	-30°C to 70°C (-22°F to 158°F)	-30°C to 70°C (-22°F to 158°F)
	Enclosure Rating	NEMA 4X / IP65	NEMA 4X / IP65

Mechanical Specifications	Electrical Connections	MC4 Connector	MC4 Connector
	Housing	Plastic	Plastic
	Dimensions	125 x 150 x 22 mm (5 x 6 x 1 in)	173 x 45 x 22 mm (6.8 x 1.8 x 1 in)
	Weight	350 g (0.77 lb)	120 g (0.26 lb)
	Mounting Options	ZEP Home Run Clip M4 Screw (#10) M8 Bolt (5/16") Nail / Wood screw	Wire Clip

Compliance Information	Certifications	UL 1741 PVRSE, UL 3741, PVRSA (Photovoltaic Rapid Shutdown Array)
	RSD Initiation Method	External System Shutdown Switch or Powerwall 3 Enable Switch

### UL 3741 PV Hazard Control (and PVRSA) Compatibility

The following categories of solar module meet the UL 3741 PVHCS listing when installed with Powerwall 3 and Solar Shutdown Devices.

Tesla Solar Roof	<a href="#">PV Hazard Control System: BIPV compliance document</a>
Tesla or Hanwha (Q.PEAK Duo BLK or BLK-G6+) Modules certified for use with ZEP racking	<a href="#">PV Hazard Control System: ZS PVHCS compliance document</a>
Other module and racking combinations	<a href="#">PV Hazard Control System: Generic PV Array compliance document</a>

## CONTRACTOR INFORMATION

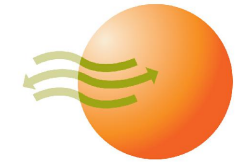

**SOUTHERN ENERGY  
MANAGEMENT**  
ENERGY EFFICIENCY & SOLAR POWER

**SOUTHERN ENERGY  
MANAGEMENT**  
5908 TRIANGLE DR, RALEIGH, NC  
27617  
PHONE: +1 984 220 0760

## PHOTOVOLTAIC ROOF MOUNT SYSTEM & ENERGY STORAGE SYSTEM

8.505 kWDC, 11.500 kWAC PV  
**SYSTEM**  
13.500kWh **ENERGY STORAGE**  
JAMES SCHMADEKE RESIDENCE  
151 FIELDSTONE DR,  
HOLLY SPRINGS, NC 27540

DATE	6/6/2024
------	----------

CREATED BY	ART
------------	-----

SCALE	NTS
-------	-----

INVERTER & BATTERY SPEC SHEET

**PV-10.1**



## CONTRACTOR INFORMATION

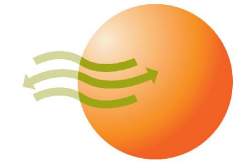

**SOUTHERN ENERGY  
MANAGEMENT**  
ENERGY EFFICIENCY & SOLAR POWER

### SOUTHERN ENERGY MANAGEMENT

5908 TRIANGLE DR, RALEIGH, NC  
27617

PHONE: +1 984 220 0760

### PHOTOVOLTAIC ROOF MOUNT SYSTEM & ENERGY STORAGE SYSTEM

8.505 kWDC, 11.500 kWAC PV  
SYSTEM

13.500kWh ENERGY STORAGE  
JAMES SCHMADEKE RESIDENCE  
151 FIELDSTONE DR,  
HOLLY SPRINGS, NC 27540

## Backup Gateway 2

Backup Gateway 2 controls connection to the grid when paired with Powerwall 3, automatically detecting outages and providing seamless transition to backup power. Backup Gateway 2 also provides energy metering for solar self-consumption, time-based control, and backup operation.

In this system configuration, Powerwall 3 acts as the Site Controller, with the Backup Gateway 2 Site Controller disabled.

Performance Specifications	<b>Model Number</b>	1232100-xx-y	<b>User Interface</b>	Tesla App
	<b>AC Voltage (Nominal)</b>	120/240 V	<b>Operating Modes</b>	Support for solar self-consumption, time-based control, and backup
	<b>Feed-in Type</b>	Split phase	<b>Backup Transition</b>	Automatic disconnect for seamless backup
	<b>Grid Frequency</b>	60 Hz	<b>Modularity</b>	Supports up to 10 AC-coupled Powerwalls
	<b>Current Rating</b>	200 A	<b>Optional Internal Panelboard</b>	200 A 6-space / 12 circuit breakers Siemens QP or Square D HOM breakers rated 10 - 80A or Eaton BR breakers rated 10 - 125A
	<b>Maximum Supply Short Circuit Current</b>	10 kA <sup>8</sup>	<b>Warranty</b>	10 years
	<b>Overcurrent Protection Device</b>	100 - 200 A, Service entrance rated <sup>9</sup>	<sup>10</sup> When protected by Class J fuses, Backup Gateway 2 is suitable for use in circuits capable of delivering not more than 22kA symmetrical amperes.	
	<b>Overvoltage Category</b>	Category IV	<sup>11</sup> The customer is expected to provide internet connectivity for Backup Gateway 2; cellular should not be used as the primary mode of connectivity. Cellular connectivity subject to network operator service coverage and signal strength.	
	<b>Internal Primary AC Meter</b>	Revenue accurate (+/- 0.2%)		
	<b>Internal Auxiliary AC Meter</b>	Revenue accurate (+/- 2%)		
	<b>Primary Connectivity</b>	Ethernet, Wi-Fi		
	<b>Secondary Connectivity</b>	Cellular (3G, LTE/4G) <sup>10</sup>		

Environmental Specifications	<b>Operating Temperature</b>	-20°C to 50°C (-4°F to 122°F)
	<b>Operating Humidity (RH)</b>	Up to 100%, condensing
	<b>Maximum Elevation</b>	3000 m (9843 ft)
	<b>Environment</b>	Indoor and outdoor rated
	<b>Enclosure Type</b>	NEMA 3R

Compliance Information	<b>Certifications</b>	UL 67, UL 869A, UL 916, UL 1741 PCS, CSA 22.2 0.19, CSA 22.2 205
	<b>Emissions</b>	FCC Part 15, ICES 003

Mechanical Specifications	<b>Dimensions</b>	660 x 411 x 149 mm (26 x 16 x 6 in)
	<b>Weight</b>	20.4 kg (45 lb)
	<b>Mounting options</b>	Wall mount, Semi-flush mount

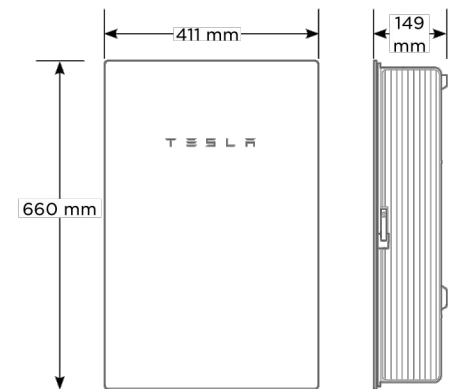

2024

Powerwall 3 Datasheet

6

<b>DATE</b>	6/6/2024
-------------	----------

<b>CREATED BY</b>	ART
-------------------	-----

<b>SCALE</b>	NTS
--------------	-----

INVERTER & BATTERY SPEC SHEET

## PV-10.2



# Powerwall 3 Example System Configurations

## Powerwall 3 with Backup Switch

Whole Home Backup

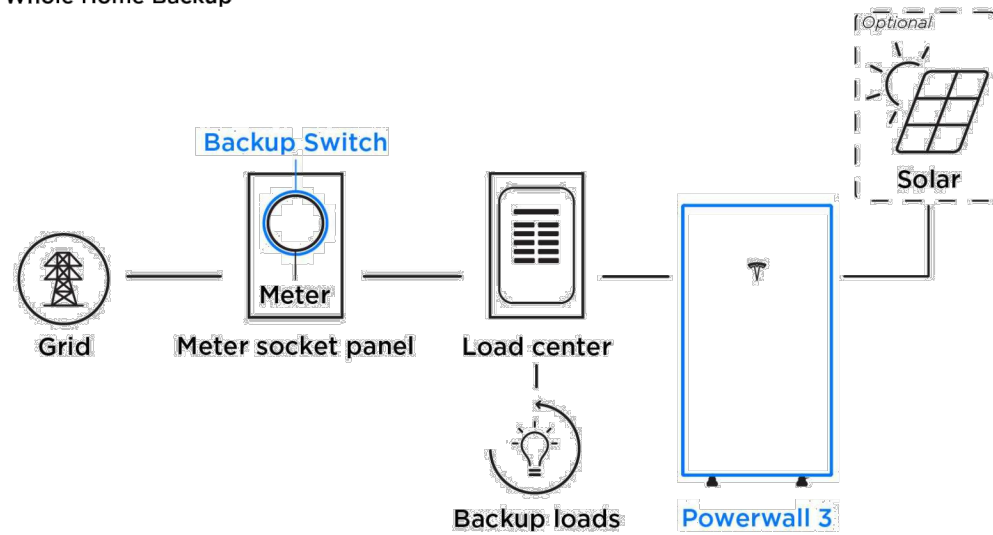

## Powerwall 3 with Backup Gateway 2

Partial Home Backup

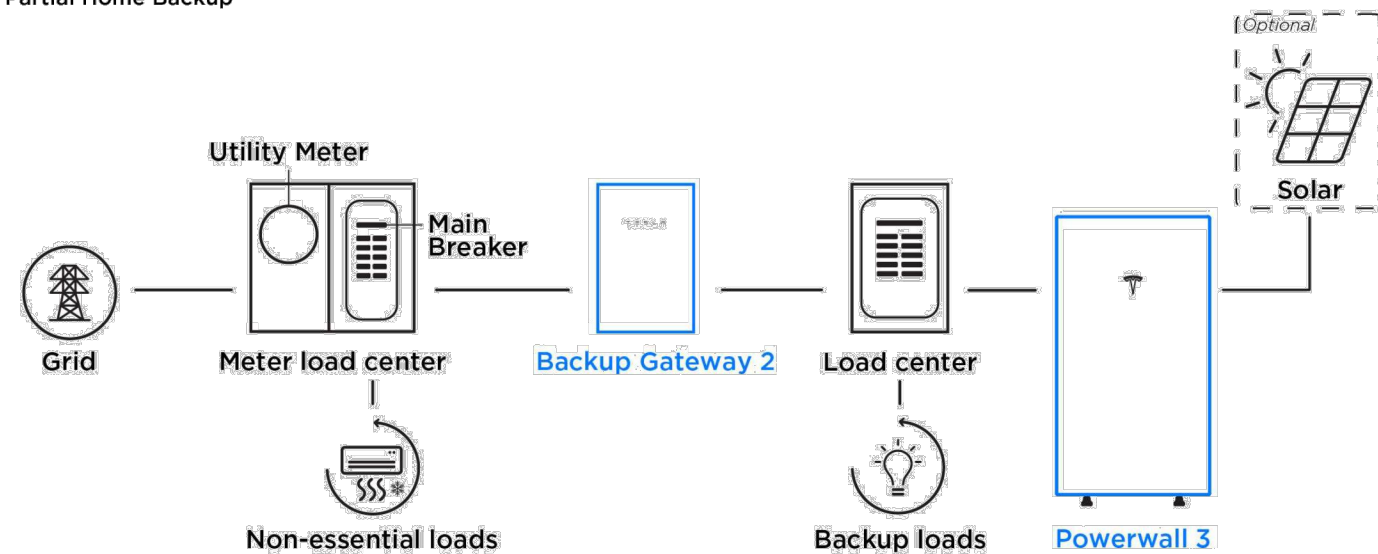

## CONTRACTOR INFORMATION

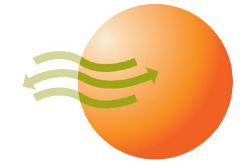

**SOUTHERN ENERGY  
MANAGEMENT**  
ENERGY EFFICIENCY & SOLAR POWER

### SOUTHERN ENERGY MANAGEMENT

5908 TRIANGLE DR, RALEIGH, NC  
27617

PHONE: +1 984 220 0760

### PHOTOVOLTAIC ROOF MOUNT SYSTEM & ENERGY STORAGE SYSTEM

8.505 kWDC, 11.500 kWAC PV  
SYSTEM

13.500kWh ENERGY STORAGE  
JAMES SCHMADEKE RESIDENCE  
151 FIELDSTONE DR,  
HOLLY SPRINGS, NC 27540

DATE	6/6/2024
------	----------

CREATED BY	ART
------------	-----

SCALE	NTS
-------	-----

INVERTER & BATTERY SPEC SHEET

**PV-10.3**

# Product datasheet

Specifications



Control station, Harmony XALD, XALK, plastic, yellow, 1 red mushroom head push button 40mm, emergency stop push pull 1 NC, unmarked

XALK198

## Main

Range Of Product	Harmony XALK
Product Or Component Type	Complete control station
Device Short Name	XALK
Product Destination	For XB5 Ø 22 mm control and signalling units
Control Station Application	Emergency stop function Emergency switching off function
Colour Of Base Of Enclosure	Light grey (RAL 7035)
Colour Of Cover	Yellow (RAL 1021)
Material	Polycarbonate
Operator Profile	1 mushroom head push-button
Operators Description	Red unmarked 1 NC
Reset	Push-pull
Control Station Composition	1 mushroom head Ø 40 mm push-button, red 1 NC unmarked marking
Contact Operation	Slow-break

## Complementary

Cable Entry	1 knock-out for cable entry 0...14 mm 2 knock-outs for Pg 13 cable gland and ISO M20 0...12 mm
Net Weight	0.183 kg
Resistance To High Pressure Washer	7000000 Pa at 55 °C, distance : 0.1 m
Positive Opening	With conforming to EN/IEC 60947-5-1 appendix K
Operating Travel	1.5 mm (NC changing electrical state) 4.3 mm (total travel)
Operating Force	50 N
Mechanical Durability	300000 cycles
Connections - Terminals	Screw clamp terminals, <= 2 x 1.5 mm² with cable end conforming to EN/IEC 60947-1 Screw clamp terminals, >= 1 x 0.22 mm² without cable end conforming to EN/IEC 60947-1
Tightening Torque	0.8...1.2 N.m conforming to EN/IEC 60947-1
Shape Of Screw Head	Cross compatible with Phillips no 1 screwdriver Cross compatible with pozidriv No 1 screwdriver Slotted compatible with flat Ø 4 mm screwdriver Slotted compatible with flat Ø 5.5 mm screwdriver
Contacts Material	Silver alloy (Ag/Ni)

Disclaimer: This documentation is not intended as a substitute for and is not to be used for determining suitability or reliability of these products for specific user applications

Short-Circuit Protection	10 A cartridge fuse type gG conforming to EN/IEC 60947-5-1
[Ith] Conventional Free Air Thermal Current	10 A conforming to EN/IEC 60947-5-1
[Ui] Rated Insulation Voltage	600 V (pollution degree 3) conforming to EN/IEC 60947-1
[Uimp] Rated Impulse Withstand Voltage	6 kV conforming to EN/IEC 60947-1
[Ie] Rated Operational Current	3 A at 240 V, AC-15, A600 conforming to EN/IEC 60947-5-1 6 A at 120 V, AC-15, A600 conforming to EN/IEC 60947-5-1 0.1 A at 600 V, DC-13, Q600 conforming to EN/IEC 60947-5-1 0.27 A at 250 V, DC-13, Q600 conforming to EN/IEC 60947-5-1 0.55 A at 125 V, DC-13, Q600 conforming to EN/IEC 60947-5-1 1.2 A at 600 V, AC-15, A600 conforming to EN/IEC 60947-5-1

Electrical Durability	1000000 cycles, AC-15, 2 A at 230 V, operating rate <3600 cyc/h, load factor: 0.5 conforming to EN/IEC 60947-5-1 appendix C 1000000 cycles, AC-15, 3 A at 120 V, operating rate <3600 cyc/h, load factor: 0.5 conforming to EN/IEC 60947-5-1 appendix C 1000000 cycles, AC-15, 4 A at 24 V, operating rate <3600 cyc/h, load factor: 0.5 conforming to EN/IEC 60947-5-1 appendix C 1000000 cycles, DC-13, 0.2 A at 110 V, operating rate <3600 cyc/h, load factor: 0.5 conforming to EN/IEC 60947-5-1 appendix C 1000000 cycles, DC-13, 0.5 A at 24 V, operating rate <3600 cyc/h, load factor: 0.5 conforming to EN/IEC 60947-5-1 appendix C
-----------------------	---

Electrical Reliability	Λ < 10exp(-6) at 5 V, 1 mA conforming to EN/IEC 60947-5-4 Λ < 10exp(-8) at 17 V, 5 mA conforming to EN/IEC 60947-5-4
------------------------	---

## Environment

Protective Treatment	TH
Ambient Air Temperature For Storage	-40...70 °C
Ambient Air Temperature For Operation	-40...70 °C
Overvoltage Category	Class II conforming to IEC 60536
Ip Degree Of Protection	IP66 conforming to IEC 60529 IP67 IP69 IP69K
Nema Degree Of Protection	NEMA 13 NEMA 4X
Ik Degree Of Protection	IK03 conforming to EN 50102
Standards	EN/IEC 60947-5-5 EN/IEC 60947-1 CSA C22.2 No 14 EN/IEC 60947-5-1 JIS C 4520 UL 508 EN/IEC 60947-5-4 IEC 60364-5-53

Vibration Resistance	5 gn (f= 12...500 Hz) conforming to IEC 60068-2-6
----------------------	---

Shock Resistance	30 gn (duration = 18 ms) for half sine wave acceleration conforming to IEC 60068-2-27 50 gn (duration = 11 ms) for half sine wave acceleration conforming to IEC 60068-2-27
------------------	--

## Packing Units

Unit Type Of Package 1	PCE
Number Of Units In Package 1	1
Package 1 Height	9.7 cm
Package 1 Width	7.1 cm
Package 1 Length	7.1 cm

## CONTRACTOR INFORMATION

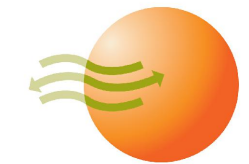

**SOUTHERN ENERGY MANAGEMENT**  
ENERGY EFFICIENCY & SOLAR POWER

### SOUTHERN ENERGY MANAGEMENT

5908 TRIANGLE DR, RALEIGH, NC 27617  
PHONE: +1 984 220 0760

### PHOTOVOLTAIC ROOF MOUNT SYSTEM & ENERGY STORAGE SYSTEM

8.505 kWDC, 11.500 kWAC PV SYSTEM  
13.500kWh ENERGY STORAGE  
JAMES SCHMADEKE RESIDENCE  
151 FIELDSTONE DR,  
HOLLY SPRINGS, NC 27540

DATE 6/6/2024

CREATED BY ART

SCALE NTS

ESS DISCONNECT SWITCH SPEC SHEET

**PV-10.4**





### The Respect Your Roof Deserves

When integrating with a home, solar attachments must be dependable for the lifetime of the rooftop. Due to recent innovations, many asphalt shingles have bonded courses. A mount that protects without the need to pry shingles can really speed things up.

Halo UltraGrip®(HUG®) is here to respect the roof. Its Halo is a cast-aluminum barrier that encases the UltraGrip, our industrial-grade, foam-and-mastic seal. This allows HUG to accelerate the installation process and provide the utmost in waterproofing protection. Give your roof a HUG.®



**UltraGrip® Seal Technology**  
HUG UltraGrip utilizes a state-of-the-art seal design that uses a unique, foam-and-mastic combination. The foam-backed adhesive provides an entirely new flashing system that conforms and adheres to every nook and cranny of composition shingles, filling gaps and shingle step-downs (up to 1/8" in height).

**Multi-Tiered Waterproofing**  
HUG® utilizes a multi-tiered stack of components to provide revolutionary waterproofing protection. The Halo cast-aluminum, raised-perimeter foundation surrounds the UltraGrip base—a foam-backed mastic seal combination that prevents water intrusion by adhering and sealing with the shingle surface.

Halo UltraGrip™ is part of the QuickMount® product line.

Tech Brief



**Rafter & Deck Mounting Options**  
Mount HUG® to the roof rafters, the roof deck, or both with our custom-engineered RD (rafter-or-deck) Structural Screw. The RD Structural Screw anchors HUG to the roof with an EPDM sealing washer, completing the stack of waterproofing barriers. See backside for more installation information.



**ETL** Triple Rated & Certified to Respect the Roof™  
UL 2703, 441 (27)  
TAS 100(A)-95  
Intertek

Tech Brief

### Adaptive, Rafter-Friendly Installation

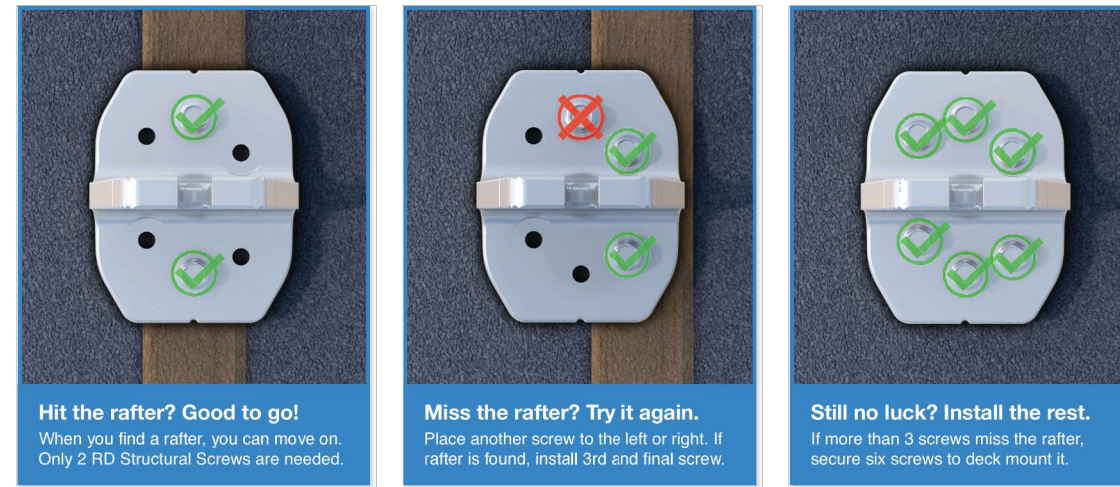

**Hit the rafter? Good to go!**  
When you find a rafter, you can move on. Only 2 RD Structural Screws are needed.

**Miss the rafter? Try it again.**  
Place another screw to the left or right. If rafter is found, install 3rd and final screw.

**Still no luck? Install the rest.**  
If more than 3 screws miss the rafter, secure six screws to deck mount it.

### Trusted Strength & Less Hassle



**25-Year Warranty**  
Product guaranteed free of impairing defects.

Structural capacities of HUG® were reviewed in many load directions, with racking rail running cross-slope or up-slope in relation to roof pitch.

For further details, see the HUG certification letters for attaching to rafters and decking.

IronRidge designed the HUG, in combination with the RD Structural Screw to streamline installs, which means the following:

- No prying shingles
- No roof nail interference
- No pilot holes necessary
- No sealant (in most cases)
- No butyl shims needed

#### Attachment Loading

The rafter-mounted HUG has been tested and rated to support 1004 (lbs) of uplift and 368 (lbs) of lateral load.

#### Structural Design

Parts are designed and certified for compliance with the International Building Code & ASCE/SEI-7.

#### Water Seal Ratings

HUG passed both the UL 441 Section 27 "Rain Test" and TAS 100(A)-95 "Wind Driven Rain Test" by Intertek.

#### UL 2703 System

Systems conform to UL 2703 mechanical and bonding requirements. See Flush Mount Manual for more info.

## CONTRACTOR INFORMATION

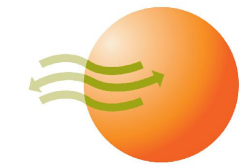

**SOUTHERN ENERGY MANAGEMENT**  
ENERGY EFFICIENCY & SOLAR POWER

**SOUTHERN ENERGY MANAGEMENT**  
5908 TRIANGLE DR, RALEIGH, NC 27617  
PHONE: +1 984 220 0760

### PHOTOVOLTAIC ROOF MOUNT SYSTEM & ENERGY STORAGE SYSTEM

8.505 kWDC, 11.500 kWAC PV SYSTEM  
13.500kWh ENERGY STORAGE  
JAMES SCHMADEKE RESIDENCE  
151 FIELDSTONE DR,  
HOLLY SPRINGS, NC 27540

DATE 6/6/2024

CREATED BY ART

SCALE NTS

MOUNT SPEC SHEET

**PV-11**

Cut Sheet



### QuickMount® Halo UltraGrip®

Release Liner shown for reference

RD STRUCTURAL SCREW PN RD-1430-01-M1 SOLD SEPARATELY SHOWN FOR REFERENCE

ITEM NO	DESCRIPTION	QTY IN KIT
1	QM Halo UltraGrip(Mill or Black)	1

PART NUMBER	DESCRIPTION
QM-HUG-01-M1	Halo UltraGrip - Mill
QM-HUG-01-B1	Halo UltraGrip - Black

© 2023 IronRidge, Inc. All rights reserved. Visit www.ir-patents.com for patent information. QM-HUG-01-B1 or QM-HUG-01-M1 Cut Sheet Rev 1.01

Cut Sheet

1. Halo UltraGrip

Dimensions: .38, 3.35, 3.83, .40, 1.63, 1.56, .34, 3.00,  $\phi .26$

Property	Value
Material	300 Series Aluminium
Finish	Mill or Black

© 2023 IronRidge, Inc. All rights reserved. Visit www.ir-patents.com for patent information. QM-HUG-01-B1 or QM-HUG-01-M1 Cut Sheet Rev 1.01

Cut Sheet



### QuickMount® RD Structural Screw

ITEM NO	DESCRIPTION	QTY IN KIT
1	Self Drilling Screw, #14, Wood Tip	1
2	Washer, EPDM Backed	1

PART NUMBER	DESCRIPTION
RD-1430-01-M1	RD Structural Screw

1. Self Drilling Screw, #14, Wood Tip

Dimensions: 5/16" Head,  $\phi .43$ , .22, #14 DIA, 3.00

Property	Value
Material	300 Series Stainless Steel
Finish	Clear

2. Washer, EPDM Backed

Dimensions:  $\phi .26$ ,  $\phi .57$ , .13

Property	Value
Material	300 Series Stainless Steel
Finish	Clear

© 2022 IronRidge, Inc. All rights reserved. Visit www.ir-patents.com for patent information. QM-RD-1430-01-M1 Cut Sheet Rev 1.1

## CONTRACTOR INFORMATION

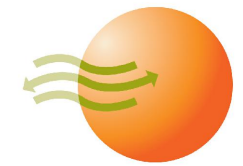

**SOUTHERN ENERGY  
MANAGEMENT**  
ENERGY EFFICIENCY & SOLAR POWER

**SOUTHERN ENERGY  
MANAGEMENT**  
5908 TRIANGLE DR, RALEIGH, NC  
27617  
PHONE: +1 984 220 0760

**PHOTOVOLTAIC ROOF  
MOUNT SYSTEM & ENERGY  
STORAGE SYSTEM**  
8.505 kWDC, 11.500 kWAC PV  
**SYSTEM**  
13.500kWh **ENERGY STORAGE**  
JAMES SCHMADEKE RESIDENCE  
151 FIELDSTONE DR,  
HOLLY SPRINGS, NC 27540

DATE	6/6/2024
CREATED BY	ART
SCALE	NTS

MOUNT SPEC SHEET

**PV-11.1**





## XR Rail® Family

Tech Brief

### Solar Is Not Always Sunny

Over their lifetime, solar panels experience countless extreme weather events. Not just the worst storms in years, but the worst storms in 40 years. High winds capable of ripping panels from a roof, and snowfalls weighing enough to buckle a panel frame.

XR Rails® are the structural backbone preventing these results. They resist uplift, protect against buckling and safely and efficiently transfer loads into the building structure. Their superior spanning capability requires fewer roof attachments, reducing the number of roof penetrations and the amount of installation time.

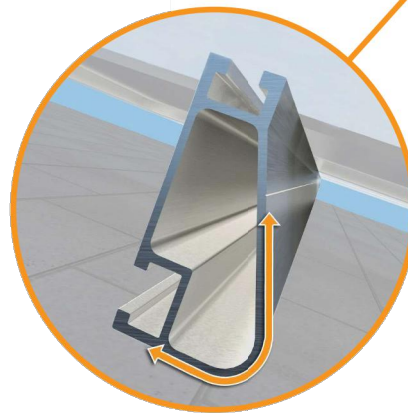
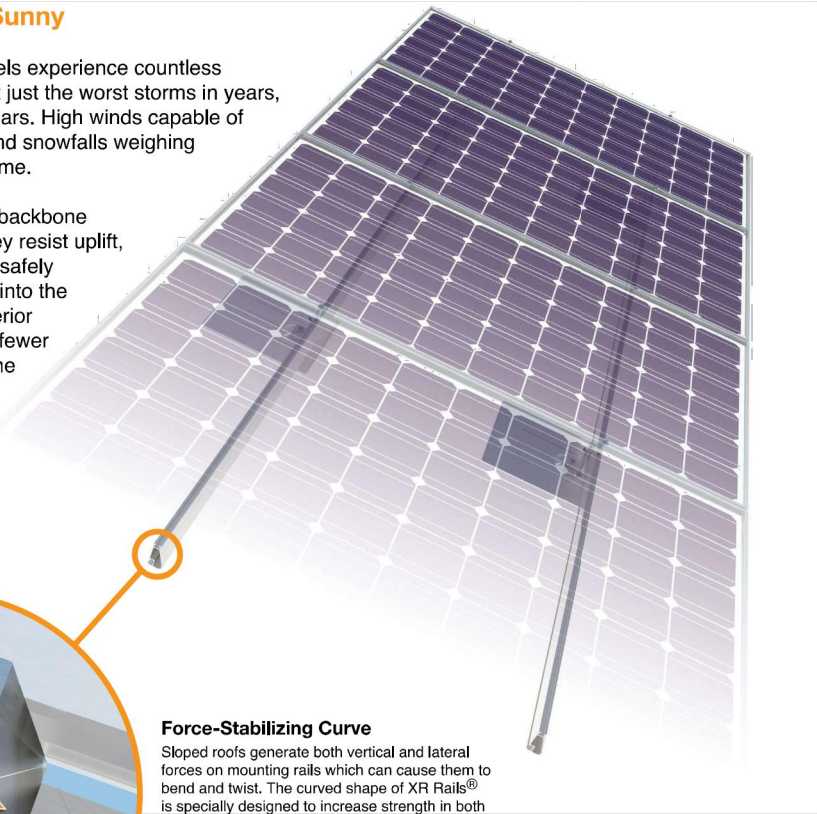

**Force-Stabilizing Curve**  
Sloped roofs generate both vertical and lateral forces on mounting rails which can cause them to bend and twist. The curved shape of XR Rails® is specially designed to increase strength in both directions while resisting the twisting. This unique feature ensures greater security during extreme weather and a longer system lifetime.

#### Compatible with Flat & Pitched Roofs



XR Rails® are compatible with FlashFoot® and other pitched roof attachments.



IronRidge® offers a range of tilt leg options for flat roof mounting applications.

#### Corrosion-Resistant Materials

All XR Rails® are made of 6000-series aluminum alloy, then protected with an anodized finish. Anodizing prevents surface and structural corrosion, while also providing a more attractive appearance.



## XR Rail® Family

The XR Rail® Family offers the strength of a curved rail in three targeted sizes. Each size supports specific design loads, while minimizing material costs. Depending on your location, there is an XR Rail® to match.

Tech Brief



**XR10**

XR10 is a sleek, low-profile mounting rail, designed for regions with light or no snow. It achieves spans up to 6 feet, while remaining light and economical.

- 6' spanning capability
- Moderate load capability
- Clear & black anodized finish
- Internal splices available



**XR100**

XR100 is a residential and commercial mounting rail. It supports a range of wind and snow conditions, while also maximizing spans up to 10 feet.

- 10' spanning capability
- Heavy load capability
- Clear & black anodized finish
- Internal splices available



**XR1000**

XR1000 is a heavyweight among solar mounting rails. It's built to handle extreme climates and spans up to 12 feet for commercial applications.

- 12' spanning capability
- Extreme load capability
- Clear anodized finish
- Internal splices available

### Rail Selection

The table below was prepared in compliance with applicable engineering codes and standards.\* Values are based on the following criteria: ASCE 7-16, Gable Roof Flush Mount, Roof Zones 1 & 2e, Exposure B, Roof Slope of 8 to 20 degrees and Mean Building Height of 30 ft. Visit IronRidge.com for detailed certification letters.

Load		Rail Span					
Snow (PSF)	Wind (MPH)	4'	5' 4"	6'	8'	10'	12'
None	90						
	120						
	140	XR10		XR100		XR1000	
	160						
20	90						
	120						
	140						
	160						
30	90						
	160						
40	90						
	160						
80	160						
	160						
120	160						
	160						

\*Table is meant to be a simplified span chart for conveying general rail capabilities. Use approved certification letters for actual design guidance.

## CONTRACTOR INFORMATION

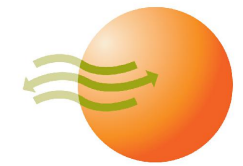

**SOUTHERN ENERGY  
MANAGEMENT**  
ENERGY EFFICIENCY & SOLAR POWER

### SOUTHERN ENERGY MANAGEMENT

5908 TRIANGLE DR, RALEIGH, NC  
27617  
PHONE: +1 984 220 0760

### PHOTOVOLTAIC ROOF MOUNT SYSTEM & ENERGY STORAGE SYSTEM

8.505 kWDC, 11.500 kWAC PV  
SYSTEM

13.500kWh ENERGY STORAGE  
JAMES SCHMADEKE RESIDENCE  
151 FIELDSTONE DR,  
HOLLY SPRINGS, NC 27540

DATE 6/6/2024

CREATED BY ART

SCALE NTS

RAIL SPEC SHEET

**PV-12**

**CONTRACTOR INFORMATION**

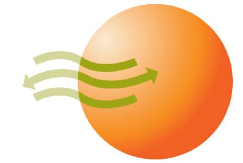

**SOUTHERN ENERGY**  
MANAGEMENT  
ENERGY EFFICIENCY & SOLAR POWER

**SOUTHERN ENERGY MANAGEMENT**  
5908 TRIANGLE DR, RALEIGH, NC 27617  
PHONE: +1 984 220 0760

**PHOTOVOLTAIC ROOF MOUNT SYSTEM & ENERGY STORAGE SYSTEM**  
8.505 kWDC, 11.500 kWAC PV SYSTEM  
13.500kWh ENERGY STORAGE  
JAMES SCHMADEKE RESIDENCE  
151 FIELDSTONE DR,  
HOLLY SPRINGS, NC 27540

<b>DATE</b>	6/6/2024
<b>CREATED BY</b>	ART
<b>SCALE</b>	NTS

INSTALLATION MANUAL  
**PV-13**

**MODULE COMPATIBILITY**

Sunspark	Sunspark modules with 40 mm frames SYY-xxxZ-A Where "YY" can be MX or ST; and "Z" can be M, MB, M3, M3B, P or W; and "A" can be 60 or 72
Suntech	Suntech modules with 35 and 40 mm frames STPxxxy-zz/aa Where "y" is blank or S; and "zz" can be 20, 24, A60, A72U, B60 or B72; and "aa" can be Vd, Vem, Vfw, Vfh, Vnh, Wdb, Wde, Wd, Wfbb or Wnhb
Talesun	Talesun modules with 30, 35 and 40 mm frames TAByZZaa-xxx-b Where "A" can be D or P; "B" can be 6 or 7; "y" can be blank, F, G, H, I or L; "ZZ" can be 54, 60, 66, 72 or 78; "aa" can be M, M(H), or P; and "b" can be blank, B, T, or (H)
Tesla	Tesla modules with 40 mm frames TxxxY Where "Y" can be H or S
Thornova	Thornova Modules with 30 and 35 mm frames TS-YYZZ(XXX)-X Where "YY" can be BB, BG or BGT; "ZZ" can be 54, 60 or 72; and "X" can be blank or X
Trina	Trina Modules with 30, 35 and 40 mm frames TSM-xxxYYZZ Where "YY" can be DD05, DD06, DD14, DE14, DE15, DE15V, DEG15, DEG15VC, DE18M, DEG18MC, DE09, DE19, DEG19C.20, DE06X, PA05, PC05, PD05, PD06, PA14, PC14, PD14, PE14, PE15, NEG19RC or NE09RC ; and "ZZ" can be blank, .05, .05(II), .08, .08(II), .10, .18, .08D, .18D, 0.82, .002, .00S, 05S, 08S, .20, .20(II), A, A.05, A.08, A.10, A.18, (II), A(II), A.05(II), A.08(II), A.082(II), A.10(II), A.18(II), C.05, C.07, C.05(II), C.07(II), H, H(II), H.05(II), H.08(II), HC.20(II), HC.20(II), M, M(II), M.05(II), MC.20(II)
Universal	Universal Solar modules with 35 mm frames UNI-xxx-yyyZZZ-aa Where "yyy" can be 108, 120 or 144; "ZZZ" can be M, MH, BMH; and "aa" can be blank, BB or DG
URE	URE modules with 35 mm frames DyZxxxaa Where "D" can be D or F; "y" can be A, B, 6 or 7; "Z" can be K, L or M; and "aa" can be C8G, H3A, H4A, H8A, L4A, E7G-BB, E8G, E8G-BB, MFG, MFG-BB or M7G-BB
Vikram	Vikram solar modules with 35 and 40 mm frames XVSYy.ZZ.AAA.bb Where "X" can be blank, Paradea, Prexos or Somera; "yy" can be M, P, MBB, MDH, MDHT, MH, MS, MHBB, or PBB; "ZZ" can be 54, 60 or 72; "AAA" is the module power rating; and "bb" can be 03, 04 or 05
VSUN	VSUN modules with 30, 35 and 40 mm frames VSUNxxxA-YYz-aa Where "A" can be blank or N; "YY" can be 60, 72, 108, 120, 132, 144; "z" can be M, P, MH, PH, or BMH; and "aa" can be blank, BB, BW, or DG
Waaree	Waaree modules with 35 and 40 mm frames AAyy-xxx Where "AA" can be WS or Bi; and "yy" can be blank, M, MB, MD, MDI, MDIB, 33, 55, 57 or 66
Winaico	Winaico modules with 35 and 40 mm frames Wsy-xxxZa Where "y" can be either P or T; "Z" can be either M, P, or MX; and "a" can be blank or 6

**MODULE COMPATIBILITY**

Yingli	Yingli modules with 30, 35 and 40 mm frames YLxxxZ-yy Where "Z" can be D or P; "yy" can be blank, 29b, 30b, 34d, 35b, 36b, 37e 1/2, 37e 1500V 1/2, 40d, 49e 1/2 or 49e 1500V 1/2
Yotta	Yotta modules with 30 and 35 mm frames YSM-Bxxx-ZZ-72-1 Where "ZZ" can be 06 or 10
Zeus	Zeus Solar Modules with 40 mm frames ZxxxM-HB
ZN Shine	ZN Shine modules with 30 and 35 mm frames ZXY-AAA-xxx/M Where "Y" can be 6, 7 or 8; "AAA" can be 72, NH120, NH144, NHDB144, NHLDD144, SH108, SH144, SHDB144, SHLDD144 or TP120





## UFO® Family of Components

Tech Brief

### Simplified Grounding for Every Application

The UFO® family of components eliminates the need for separate grounding hardware by bonding solar modules directly to IronRidge® XR Rails®. All system types that feature the UFO® family—Flush Mount®, Tilt Mount® and Ground Mount®—are fully listed to the UL 2703 standard.

UFO® hardware forms secure electrical bonds with both the module and the rail, resulting in many parallel grounding paths throughout the system. This leads to safer and more reliable installations.

Only for installation and use with IronRidge products in accord with written instructions. See [IronRidge.com/UFO](http://IronRidge.com/UFO)

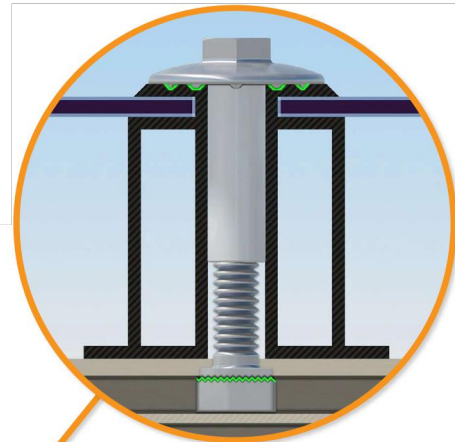

**Universal Fastening Object (UFO®)**  
The UFO® securely bonds solar modules to XR Rails®. It comes assembled and lubricated, and can fit a wide range of module heights.



**Stopper Sleeve**  
The Stopper Sleeve snaps onto the UFO®, converting it into a bonded end clamp.



**BOSS® Splice**  
Bonded Structural Splice connects rails with built-in bonding teeth. No tools or hardware needed.

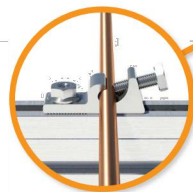

**Grounding Lug**  
A single Grounding Lug connects an entire row of PV modules to the grounding conductor.



**Bonded Attachments**  
The bonding bolt attaches and bonds the L-foot® to the rail. It is installed with the same socket as the rest of the system.

### System Diagram

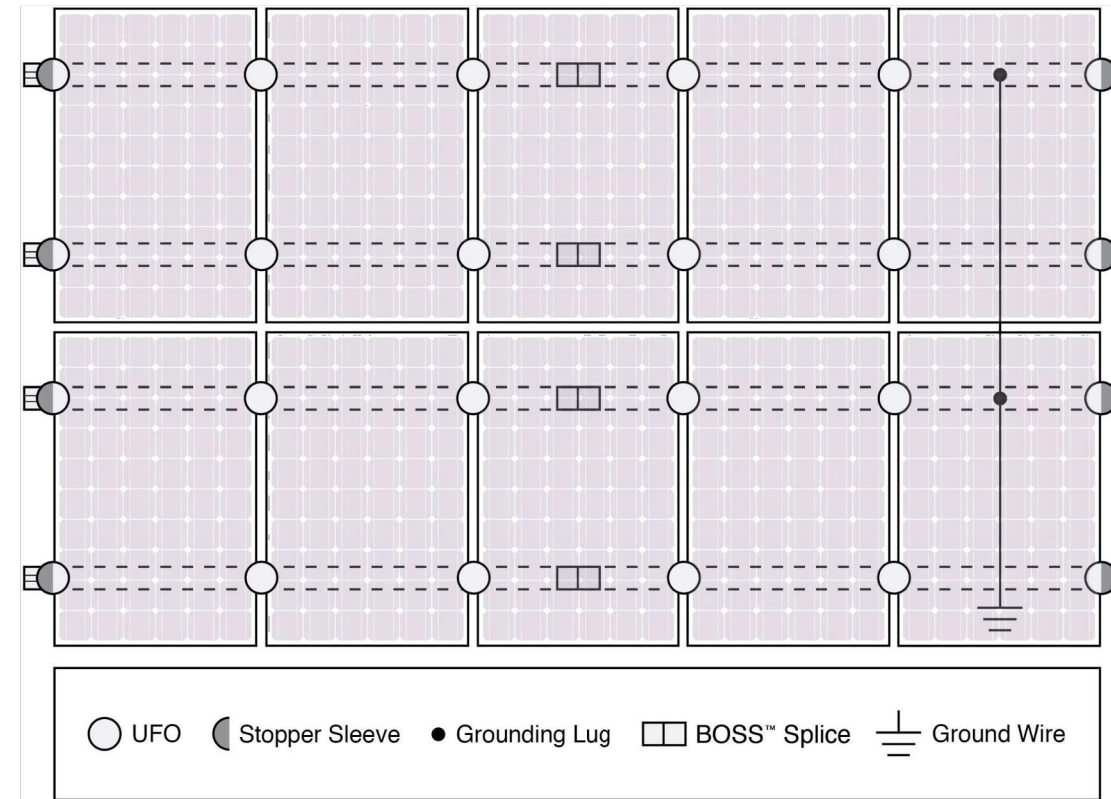

⚠ Approved Enphase microinverters can provide equipment grounding of IronRidge systems, eliminating the need for grounding lugs and field installed equipment ground conductors (EGC). A minimum of two microinverters mounted to the same rail and connected to the same Engage cable is required. Refer to installation manuals for additional details.

### UL Certification

The IronRidge® Flush Mount®, Tilt Mount®, and Ground Mount Systems have been listed to UL 2703 by Intertek Group plc.

UL 2703 is the standard for evaluating solar mounting systems. It ensures these devices will maintain strong electrical and mechanical connections over an extended period of time in extreme outdoor environments.

[Go to IronRidge.com/UFO](http://Go to IronRidge.com/UFO)

### Cross-System Compatibility

Feature	Flush Mount	Tilt Mount	Ground Mount
<b>XR Rails®</b>	✓	✓	XR100 & XR1000
<b>UFO®/Stopper</b>	✓	✓	✓
<b>BOSS® Splice</b>	✓	✓	N/A
<b>Grounding Lugs</b>	1 per Row	1 per Row	1 per Array
<b>Microinverters &amp; Power Optimizers</b>	Compatible with most MLPE manufacturers. Refer to system installation manual.		
<b>Fire Rating</b>	Class A	Class A	N/A
<b>Modules</b>	Tested or Evaluated with over 400 Framed Modules. Refer to installation manuals for a detailed list.		

## CONTRACTOR INFORMATION

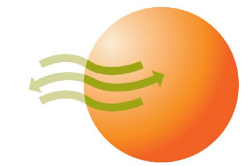

**SOUTHERN ENERGY  
MANAGEMENT**  
ENERGY EFFICIENCY & SOLAR POWER

**SOUTHERN ENERGY  
MANAGEMENT**  
5908 TRIANGLE DR, RALEIGH, NC  
27617  
PHONE: +1 984 220 0760

### PHOTOVOLTAIC ROOF MOUNT SYSTEM & ENERGY STORAGE SYSTEM

8.505 kWDC, 11.500 kWAC PV  
**SYSTEM**  
13.500kWh **ENERGY STORAGE**  
JAMES SCHMADEKE RESIDENCE  
151 FIELDSTONE DR,  
HOLLY SPRINGS, NC 27540

**DATE** 6/6/2024

**CREATED BY** ART

**SCALE** NTS

INSTALLATION MANUAL

**PV-14**