

# BRAD JORDAN

42 BRITISH LANE CAMERON NORTH CAROLINA 28326 UNITED STATES  
 35.2610157,-79.0317290

SYSTEM TIER (UTILITY): TIER 1 (6.8 KWDC\*0.85 = 5.78 KWAC)  
 SCOPE OF WORK: INSTALLATION OF SOLAR PANELS AND ASSOCIATED ELECTRICAL EQUIPMENT.

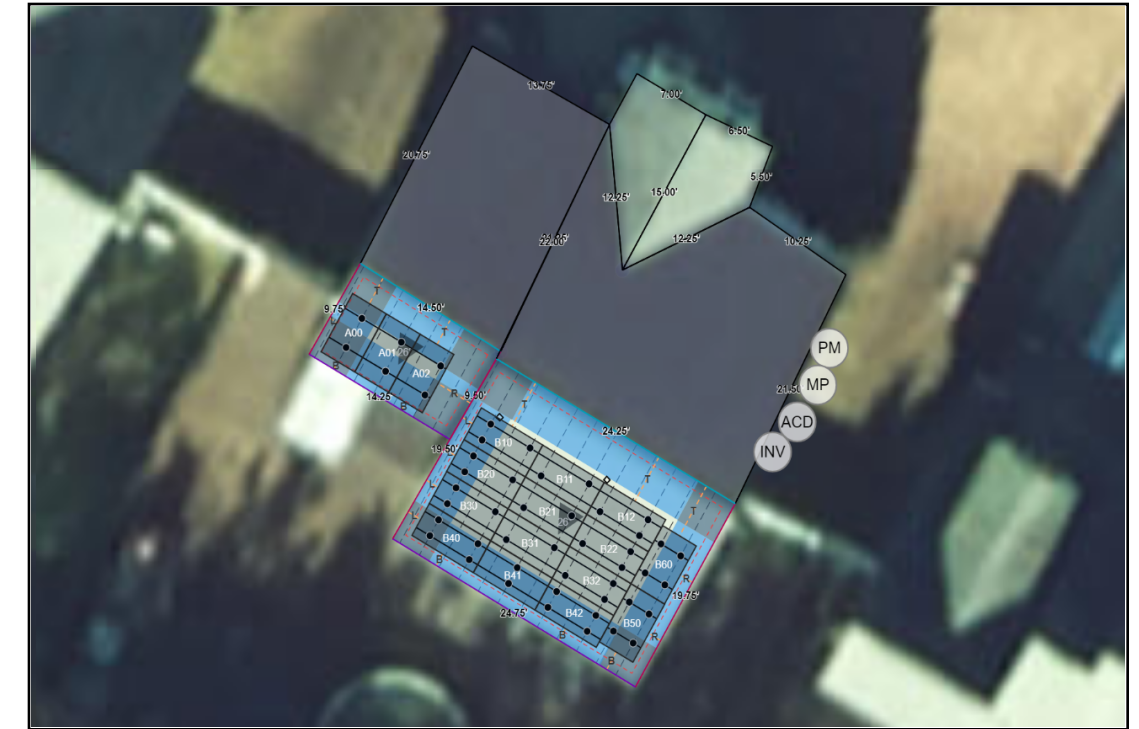
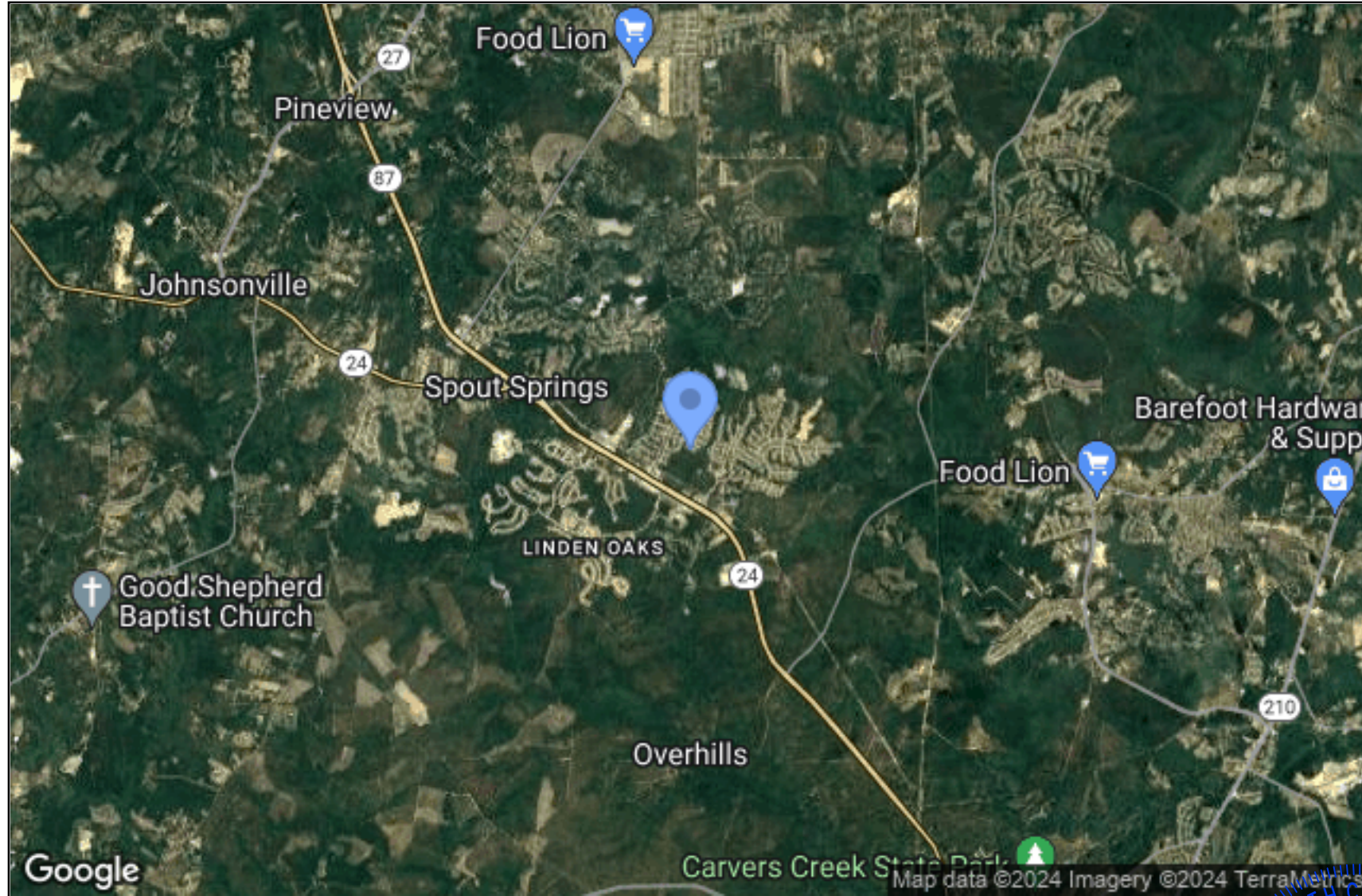

02 AERIAL

### PROJECT INFORMATION

**DISTRICTS**  
 COUNTY: HARNETT COUNTY  
 JURISDICTION: UN-INCORPORATED HARNETT

**DESIGN SPECS**  
 WIND EXPOSURE: B  
 RISK CATEGORY: II  
 WIND SPEED (MPH): 120  
 SNOW LOAD (PSF): 10

**GOVERNING CODES**  
 BUILDING: IBC 2015/ASCE 7-10  
 ELECTRICAL: NEC 2020  
 FIRE: IFC 2015

**SYSTEM**  
 SIZE (KWDC): 6.8  
 EST KWH/YR: 9633  
 # PANELS: 17  
 PANEL: REC400NP3  
 INVERTER(S): PWRCELL 7.6  
 VOLTAGE (V): 240

### SHEET INDEX

COVER	T1
LAYOUT	S1
LOCATIONS PLAN	SL1
ATTACHMENT PLAN	SP1-SP2
ATTACHMENT DETAIL	SA1
ELECTRICAL DIAGRAM	E1
LABELS	EL1
DATASHEETS	D1-D7

01 VICINITY

BRAD JORDAN	CONTRACTOR: LOTUS ENERGY & SOLAR 220 W MAIN ST, TAVARES, FL 32778 (407) 377-7437	ENGINEER: MOHAMED SAID MAHMOUD, PE 8340 LAKE WILLOW WAY, ELK GROVE, CA 95758 MOHAMED SAID MAHMOUD PE056354	DATE 04.09.24	BY RG	VER 1	DESCRIPTION INITIAL DESIGN	T1
42 BRITISH LANE CAMERON NORTH CAROLINA 28326 UNITED STATES							PAPER: ARCHB
PROJECT ID: 452024-42							SCALE:

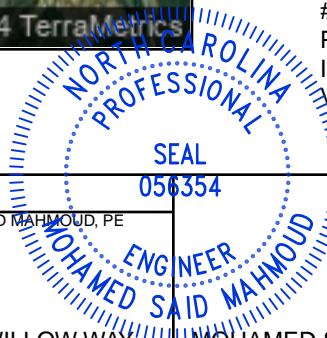

UNAUTHORIZED USE OF THIS DRAWING SET WITHOUT WRITTEN PERMISSION FROM CONTRACTOR IS IN VIOLATION OF U.S. COPYRIGHT LAWS AND WILL BE SUBJECT TO CIVIL DAMAGES AND PROSECUTIONS

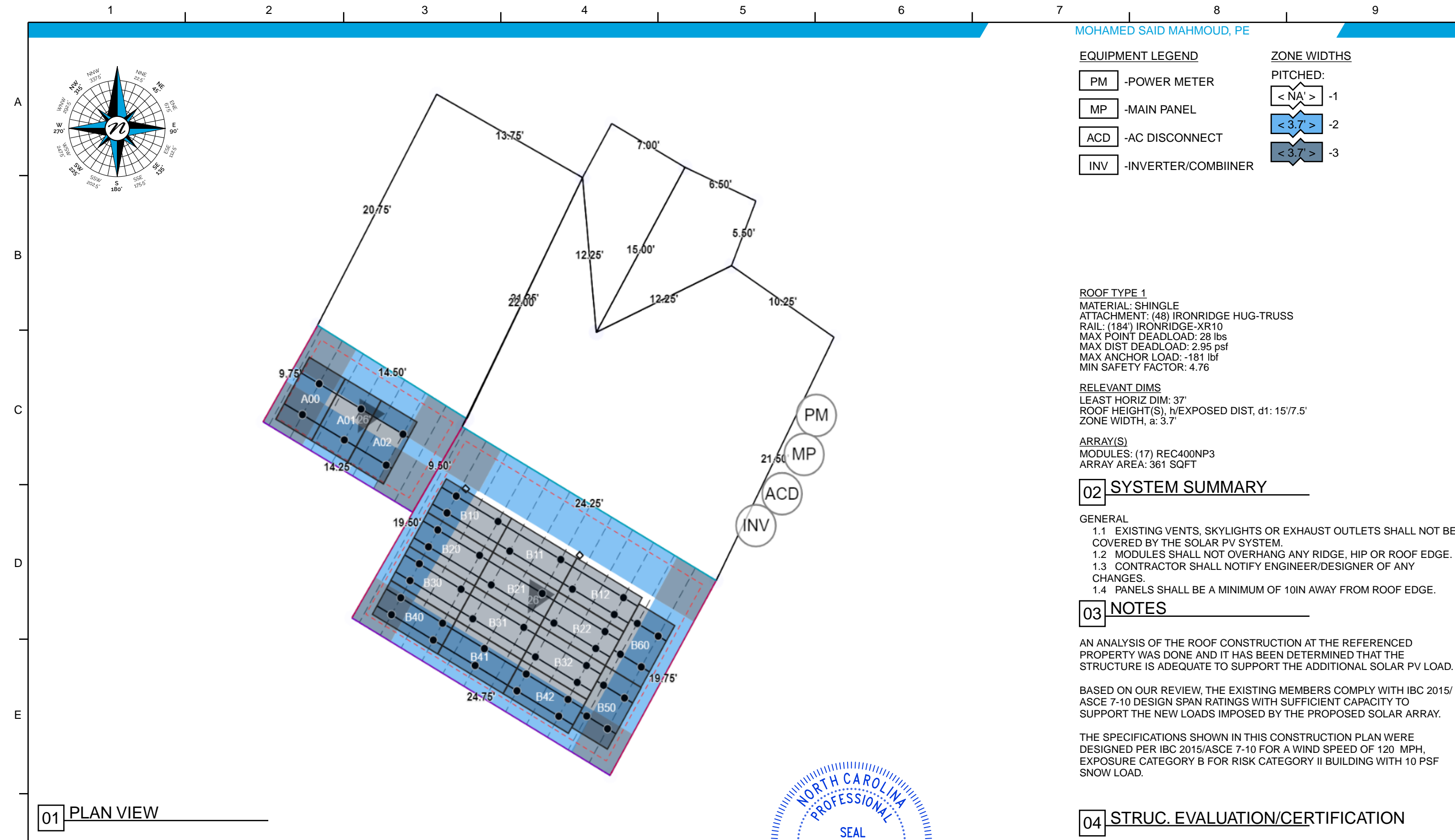

MOHAMED SAID MAHMOUD, PE

**EQUIPMENT LEGEND**

- PM -POWER METER
- MP -MAIN PANEL
- ACD -AC DISCONNECT
- INV -INVERTER/COMBINER

**ZONE WIDTHS**

- PITCHED:
- < NA' > -1
  - < 3.7' > -2
  - < 3.7' > -3

**ROOF TYPE 1**  
 MATERIAL: SHINGLE  
 ATTACHMENT: (48) IRONRIDGE HUG-TRUSS  
 RAIL: (184') IRONRIDGE-XR10  
 MAX POINT DEADLOAD: 28 lbs  
 MAX DIST DEADLOAD: 2.95 psf  
 MAX ANCHOR LOAD: -181 lbf  
 MIN SAFETY FACTOR: 4.76

**RELEVANT DIMS**  
 LEAST HORIZ DIM: 37'  
 ROOF HEIGHT(S), h/EXPOSED DIST, d1: 15'/7.5'  
 ZONE WIDTH, a: 3.7'

**ARRAY(S)**  
 MODULES: (17) REC400NP3  
 ARRAY AREA: 361 SQFT

**02 SYSTEM SUMMARY**

- GENERAL**
- 1.1 EXISTING VENTS, SKYLIGHTS OR EXHAUST OUTLETS SHALL NOT BE COVERED BY THE SOLAR PV SYSTEM.
  - 1.2 MODULES SHALL NOT OVERHANG ANY RIDGE, HIP OR ROOF EDGE.
  - 1.3 CONTRACTOR SHALL NOTIFY ENGINEER/DESIGNER OF ANY CHANGES.
  - 1.4 PANELS SHALL BE A MINIMUM OF 10IN AWAY FROM ROOF EDGE.

**03 NOTES**

AN ANALYSIS OF THE ROOF CONSTRUCTION AT THE REFERENCED PROPERTY WAS DONE AND IT HAS BEEN DETERMINED THAT THE STRUCTURE IS ADEQUATE TO SUPPORT THE ADDITIONAL SOLAR PV LOAD.

BASED ON OUR REVIEW, THE EXISTING MEMBERS COMPLY WITH IBC 2015/ ASCE 7-10 DESIGN SPAN RATINGS WITH SUFFICIENT CAPACITY TO SUPPORT THE NEW LOADS IMPOSED BY THE PROPOSED SOLAR ARRAY.

THE SPECIFICATIONS SHOWN IN THIS CONSTRUCTION PLAN WERE DESIGNED PER IBC 2015/ASCE 7-10 FOR A WIND SPEED OF 120 MPH, EXPOSURE CATEGORY B FOR RISK CATEGORY II BUILDING WITH 10 PSF SNOW LOAD.

**04 STRUC. EVALUATION/CERTIFICATION**

**01 PLAN VIEW**

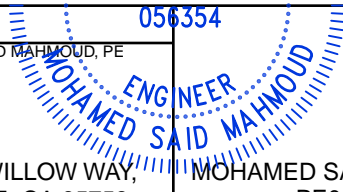
F	BRAD JORDAN	CONTRACTOR:	ENGINEER:	DATE	BY	VER	DESCRIPTION	S1
	42 BRITISH LANE CAMERON NORTH CAROLINA 28326 UNITED STATES	 LOTUS ENERGY & SOLAR 220 W MAIN ST, TAVARES, FL 32778 (407) 377-7437	 MOHAMED SAID MAHMOUD, PE 8340 LAKE WILLOW WAY, ELK GROVE, CA 95758 MOHAMED SAID MAHMOUD PE056354	04.09.24	RG	1	INITIAL DESIGN	
	PROJECT ID: 452024-42							PAPER: ARCHB
								SCALE: 1"=7.63'

UNAUTHORIZED USE OF THIS DRAWING SET WITHOUT WRITTEN PERMISSION FROM CONTRACTOR IS IN VIOLATION OF U.S. COPYRIGHT LAWS AND WILL BE SUBJECT TO CIVIL DAMAGES AND PROSECUTIONS

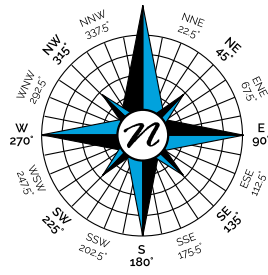

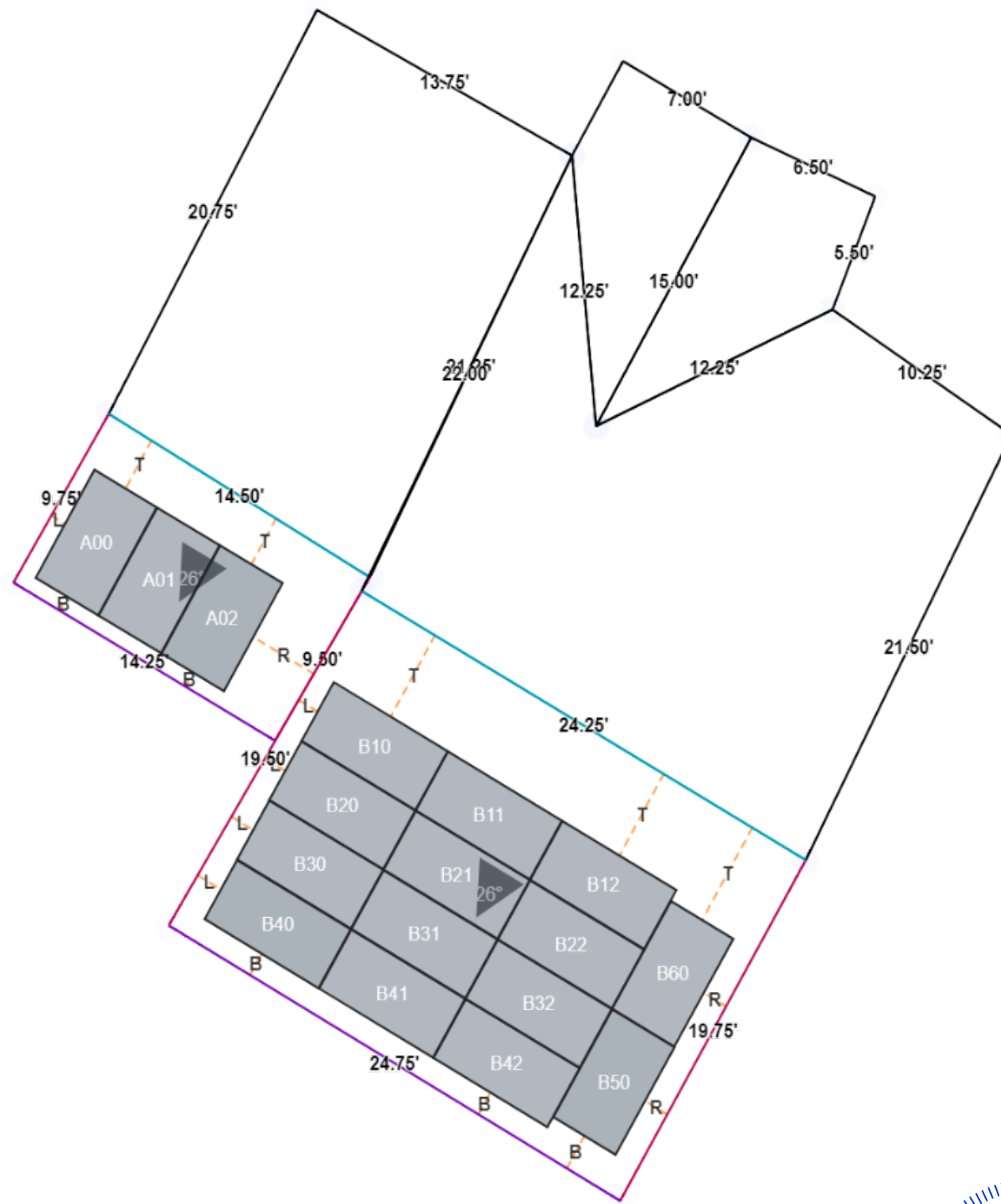

ARRAY OFFSETS

PANEL ID	SIDE	DIM (ft)
A00	T	2.48
A00	B	0.71
A00	L	0.75
A02	T	2.37
A02	R	3.31
A02	B	0.73
B10	T	4.22
B10	L	1.03
B20	L	1.11
B30	L	1.19
B40	B	1.11
B40	L	1.27
B42	B	1.13
B12	T	4.23
B50	R	1.21
B50	B	1.67
B60	T	4.78
B60	R	1.22

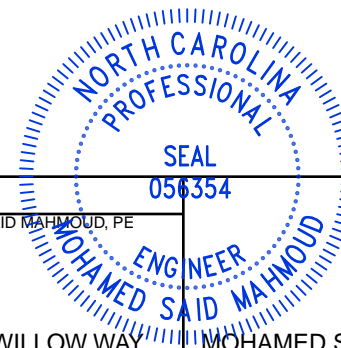

01 LOCATIONS PLAN



F	BRAD JORDAN	CONTRACTOR:	ENGINEER:	DATE	BY	VER	DESCRIPTION	SL1
	42 BRITISH LANE CAMERON NORTH CAROLINA 28326 UNITED STATES	 LOTUS ENERGY & SOLAR 220 W MAIN ST, TAVARES, FL 32778 (407) 377-7437	MOHAMED SAID MAHMOUD, PE 8340 LAKE WILLOW WAY, ELK GROVE, CA 95758 MOHAMED SAID MAHMOUD PE056354	04.09.24	RG	1	INITIAL DESIGN	
	PROJECT ID: 452024-42							PAPER: ARCHB
								SCALE: 1"=7.63'

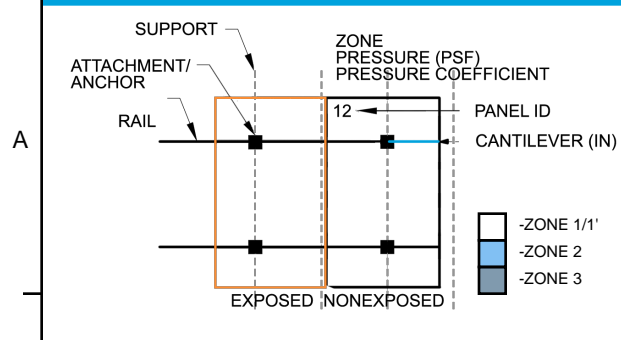

**ARRAY**  
 MODULE: (3) REC400NP3  
 TOTAL AREA: 63.74 SQFT

**HARDWARE**  
 RAIL: 21' IRONRIDGE-XR10  
 ATTACHMENT: (6) IRONRIDGE HUG-TRUSS  
 ANCHORAGE: RAFTER/TRUSS

**FRAMING**  
 SIZE: MIN. 2X4  
 SPACING: 24" OC

**ROOF**  
 MEAN HEIGHT: 15'  
 MATERIAL: SHINGLE  
 SHAPE: GABLE

**GEOGRAPHY**  
 EXPOSURE CAT: B  
 WIND SPEED: 120 MPH  
 SNOW LOAD: 10 LBS

**DEAD LOAD CALC**  
 LOADS:  
 Panel = 48lbs  
 Anchors = 1.2lbs  
 Rail = 0.72lbs/ft  
 Misc = 1.6lbs/panel

DEADLOAD PER ROW, Fdr:  
 $Fdr = (lbs/panel * \#panels/row) + (lbs/ft-rail * \#rails/row) * 2 + (misc-lbs/panel * \#panels/row)$  (lbf)

DIST DEADLOAD, Fdd:  
 $Fdd = Fdr / (area/panel * \#panels/row)$  (psf)

DEADLOAD PER ANCHOR, Fda:  
 $Fda = Fdr / (\#anchors/row)$  (lbs)

**COMPONENTS & CLADDING, 30 PT. 1**  
 CRITERIA:  
 - Panels parallel to roof surface (within 2 deg)  
 - Max height of panel above roof, h1 & h2 OF 10"  
 - Min panel gap of 0.25"  
 - Min edge distance 2\*h2  
 - Max panel chord length of 6.7'

UPLIFT ON ONE PANEL, Fup = P\*A (lbf)  
 Per ASCE 2.4, 26.11-1 & 30.4  
 $P = pasd = 0.6 * p = 0.6 * qh * (GCp - GCpi)$ , A = load area

UPLIFT PER ROW, Fur = SUM(Fup(0):Fup(n)) (lbf)  
 Where Fup(0):Fup(n) = loads from first to last panel in row

UPLIFT PER ANCHOR, Fua = Fur / (#ANCHORS/ROW) (lbf)

LOAD PER ANCHOR, Fa = 0.6 \* Fda + Fua (lbf)

SAFETY FACTOR, SF = Ftest/Fa

VELOCITY PRESSURE  $qh = 0.00256 * Kz * Kzt * Kd * V^2 = 18$  (lb/sqft)  
 Where  $Kz = 0.57$ ,  $Kzt = 1$ ,  $Kd = 0.85$ ,  $V = 120$

EXT PRESSURE COEFFICIENT, GCp:  
 GCp varies per roof & zone, 30.4: Aeff = 21.25 sqft (1 panel)

**ZONES**  
 f0: 1' (Flat)  
 f1: 1' (Flat)  
 f2: 2' (Flat)  
 f3: 3' (Flat)  
 g1: 1 (Gable)  
 g2: 2 (Gable)  
 g3: 3 (Gable)  
 h1: 1 (Hip)  
 h2: 2 (Hip)  
 h3: 3 (Hip)



LOAD CALCS PER IBC 2015/ASCE 7-10

**ROW: 0 (3 MODS)**  
 NOM SPAN: 48"  
 MAX SPAN: 66"  
 MAX CANTILEVER: 26"  
 UPLIFT/ROW, Fur: -1186 lbf  
 #ANCHORS: 6  
 LOAD/ANCHOR, Fa: -181 lbf  
 TEST LOAD/ANCHOR: -860 lbf  
 SF: 4.76  
 DIST LOAD, Fdd: 2.68 psf  
 POINT LOAD, Fda: 28.47 lbs  
 ROOF PITCH: 20-27 deg  
 PANEL TILT: 0 deg  
 AZIMUTH: 210 deg

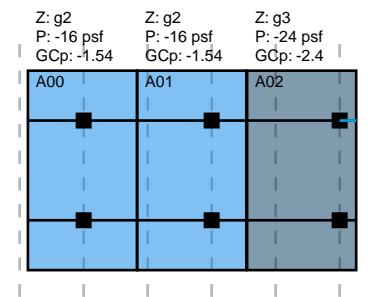

01 ATTACHMENT PLAN

F	BRAD JORDAN	CONTRACTOR:	ENGINEER:	DATE	BY	VER	DESCRIPTION	SP1
	42 BRITISH LANE CAMERON NORTH CAROLINA 28326 UNITED STATES	LOTUS ENERGY & SOLAR 220 W MAIN ST, TAVARES, FL 32778 (407) 377-7437	MOHAMED SAID MAHMOUD, PE 8340 LAKE WILLOW WAY, ELK GROVE, CA 95758 MOHAMED SAID MAHMOUD PE056354	04.09.24	RG	1	INITIAL DESIGN	
	PROJECT ID: 452024-42							PAPER: ARCHB
								SCALE:

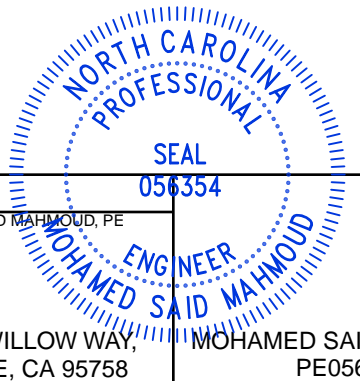

UNAUTHORIZED USE OF THIS DRAWING SET WITHOUT WRITTEN PERMISSION FROM CONTRACTOR IS IN VIOLATION OF U.S. COPYRIGHT LAWS AND WILL BE SUBJECT TO CIVIL DAMAGES AND PROSECUTIONS

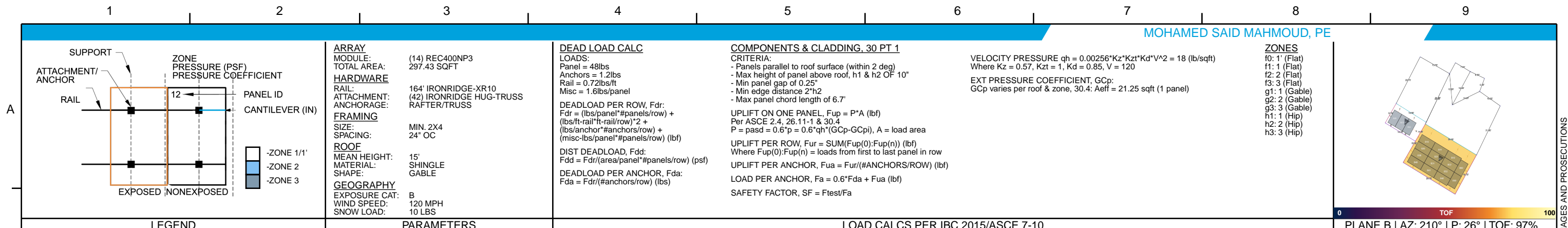

LEGEND

PARAMETERS

LOAD CALCS PER IBC 2015/ASCE 7-10

PLANE B | AZ: 210° | P: 26° | TOF: 97%

ROW	MODS	SPAN	MAX SPAN	MAX CANTILEVER	UPLIFT/ROW	#ANCHORS	LOAD/ANCHOR	TEST LOAD/ANCHOR	SF	DIST LOAD	POINT LOAD	ROOF PITCH	PANEL TILT	AZIMUTH
B	ROW: 1 (3 MODS)	72"	72"	32"	-1020 lbf	8	-114 lbf	-860 lbf	7.57	2.91 psf	23.17 lbs	20-27 deg	0 deg	210 deg
	ROW: 2 (3 MODS)	72"	72"	32"	-1020 lbf	8	-114 lbf	-860 lbf	7.57	2.91 psf	23.17 lbs	20-27 deg	0 deg	210 deg
	ROW: 3 (3 MODS)	72"	72"	32"	-1020 lbf	8	-114 lbf	-860 lbf	7.57	2.91 psf	23.18 lbs	20-27 deg	0 deg	210 deg
C	ROW: 4 (3 MODS)	48"	66"	26"	-1186 lbf	10	-107 lbf	-860 lbf	8.01	2.95 psf	18.78 lbs	20-27 deg	0 deg	210 deg
	ROW: 5 (1 MODS)	48"	66"	26"	-506 lbf	4	-118 lbf	-860 lbf	7.31	2.79 psf	14.83 lbs	20-27 deg	0 deg	210 deg
D	ROW: 6 (1 MODS)	48"	66"	26"	-340 lbf	4	-76 lbf	-860 lbf	11.3	2.79 psf	14.83 lbs	20-27 deg	0 deg	210 deg

01 ATTACHMENT PLAN

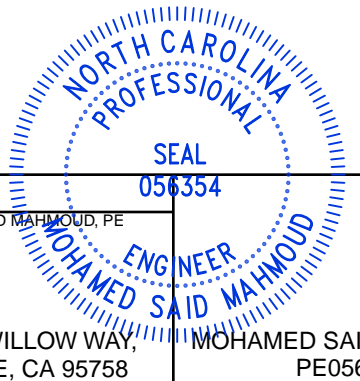

F	BRAD JORDAN	CONTRACTOR:	ENGINEER:	DATE	BY	VER	DESCRIPTION	SP2
	42 BRITISH LANE CAMERON NORTH CAROLINA 28326 UNITED STATES	LOTUS ENERGY & SOLAR 220 W MAIN ST, TAVARES, FL 32778 (407) 377-7437	MOHAMED SAID MAHMOUD, PE 8340 LAKE WILLOW WAY, ELK GROVE, CA 95758 MOHAMED SAID MAHMOUD PE056354	04.09.24	RG	1	INITIAL DESIGN	
	PROJECT ID: 452024-42							PAPER: ARCHB
								SCALE:

UNAUTHORIZED USE OF THIS DRAWING SET WITHOUT WRITTEN PERMISSION FROM CONTRACTOR IS IN VIOLATION OF U.S. COPYRIGHT LAWS AND WILL BE SUBJECT TO CIVIL DAMAGES AND PROSECUTIONS

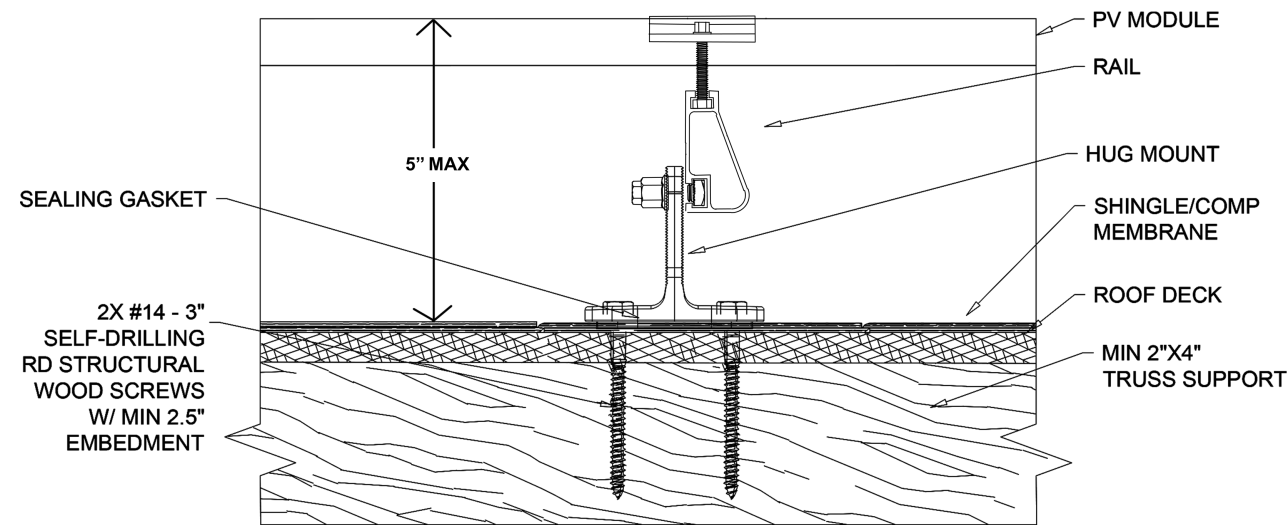

- GENERAL**
- 1.1 DESIGNED PER IBC 2015/ASCE 7-10 MINIMUM DESIGN LOADS FOR BUILDING AND OTHER STRUCTURES.
  - 1.2 CONTRACTOR IS RESPONSIBLE FOR INSTALLING PV MODULES, RACKING & RACKING SUPPORTS IN ACCORDANCE WITH THE MANUFACTURER INSTALLATION INSTRUCTIONS NOT SHOWN IN THIS PLAN.
  - 1.3 WITHDRAWAL VALUES GIVEN PER NDS BASED ON SG OF 0.5 OR MANUFACTURER SUPPLIED 3RD PARTY UPLIFT TESTING REPORTS WITH APPLICABLE SAFETY FACTORS.
  - 1.4 ALL PENETRATIONS SHALL BE FLASHED OR SEALED IN A MANNER THAT PREVENTS MOISTURE FROM ENTERING THE WALL AND ROOF USING ASTM C920 COMPLAINT SEALANT IN PILOT HOLES AND AROUND FASTENERS.
  - 1.5 THE SUPPORTING ROOF STRUCTURE SHALL BE CONVENTIONAL WOOD FRAMED CONSTRUCTION WITH PRE-ENGINEERED TRUSSES OR ROOF FRAMING MEMBERS AT A SPACING OF 24 IN MAXIMUM ON CENTER.
  - 1.6 EXISTING STRUCTURE IS ASSUMED TO BE IN COMPLIANCE WITH APPLICABLE BUILDING CODES AT THE TIME OF CONSTRUCTION.
  - 1.7 CONTRACTOR SHALL NOTIFY ENGINEER OF ANY CONDITION CHANGES.

**01 ANCHORAGE DETAIL**

**02 NOTES**

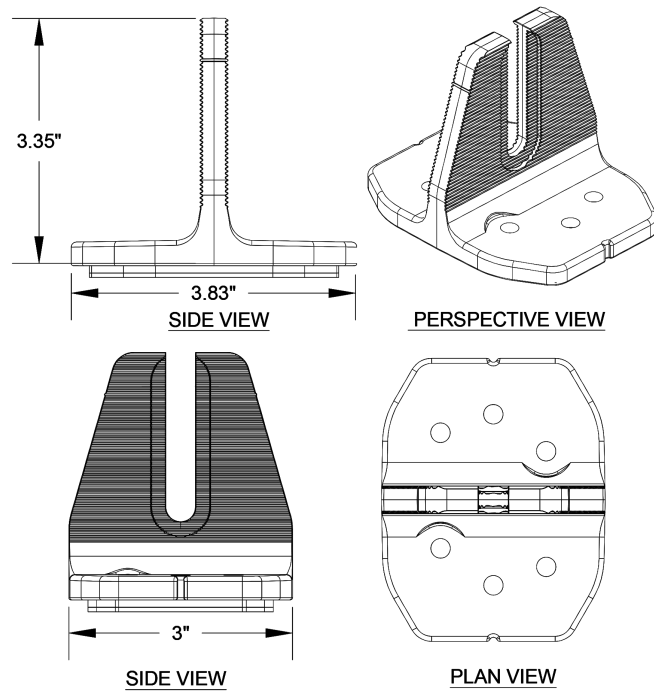

QM HALO ULTRAGRIP

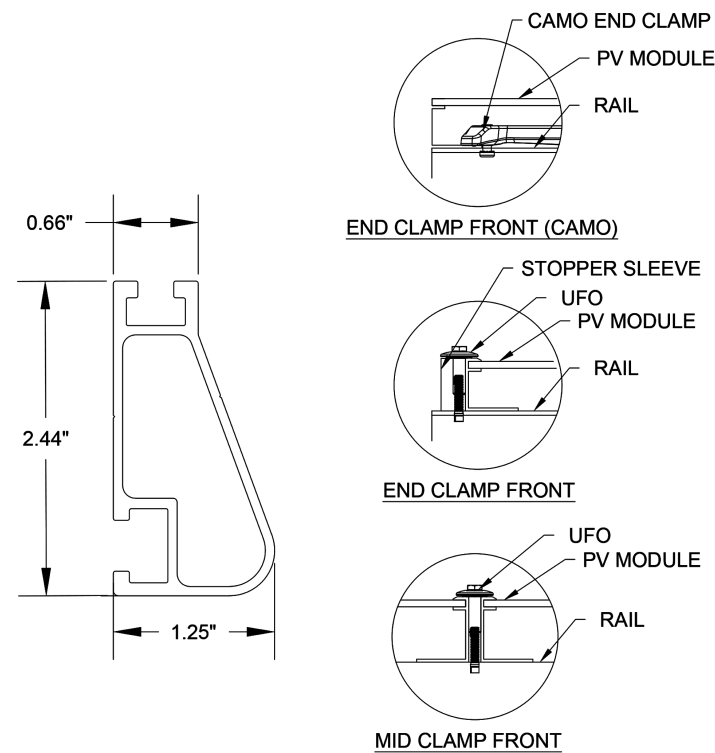

IRONRIDGE XR-10 RAIL AND CLAMPS

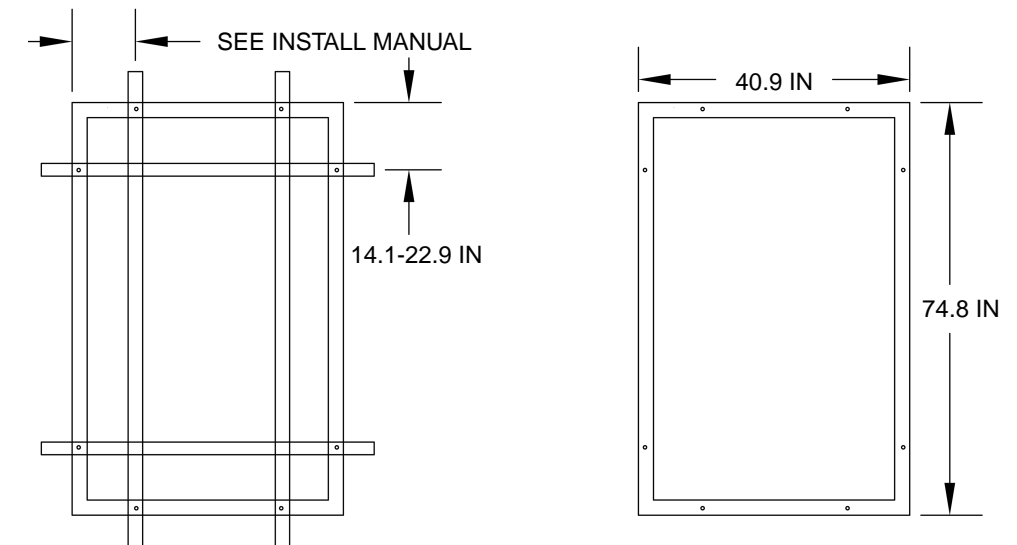

REC REC400NP3

**03 ANCHOR DETAIL**

**04 RAIL & CLAMPS DETAIL**

**05 MODULE DETAILS**

F	BRAD JORDAN	CONTRACTOR:	ENGINEER:	DATE	BY	VER	DESCRIPTION	SA1
	42 BRITISH LANE CAMERON NORTH CAROLINA 28326 UNITED STATES	LOTUS ENERGY & SOLAR 220 W MAIN ST, TAVARES, FL 32778 (407) 377-7437	MOHAMED SAID MAHMOUD, PE 8340 LAKE WILLOW WAY, ELK GROVE, CA 95758 MOHAMED SAID MAHMOUD PE056354	04.09.24	RG	1	INITIAL DESIGN	
	PROJECT ID: 452024-42							PAPER: ARCHB
								SCALE:

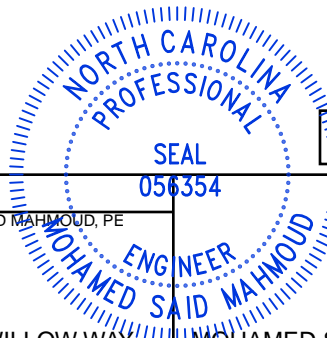

UNAUTHORIZED USE OF THIS DRAWING SET WITHOUT WRITTEN PERMISSION FROM CONTRACTOR IS IN VIOLATION OF U.S. COPYRIGHT LAWS AND WILL BE SUBJECT TO CIVIL DAMAGES AND PROSECUTIONS

**GENERAL**

- 1.1 CONTRACTOR IS RESPONSIBLE FOR COMPLYING WITH IBC 2015/ASCE 7-10 AND NEC 2020 REQUIREMENTS AND EQUIPMENT INSTALLATION INSTRUCTIONS NOT SHOWN IN THIS PLAN.
- 1.2 ALL EQUIPMENT SHALL BE LISTED PER NEC 690.4(B).
- 1.3 PV SOURCE CONDUCTORS ARE SIZED BE EXPOSED TO DIRECT SUNLIGHT WHEN INSTALLED IN RACEWAYS 7/8" OR LESS ABOVE ROOF. ADJUSTMENTS ARE BASED ON MAX CURRENT OF 16A, 35C AMBIENT TEMP, NEC 310.15(B)(2) AND T310.15(B)(1).
- 1.4 ALL EQUIPMENT SHALL BE RATED FOR INSTALL LOCATION. ROOF & OUTDOOR JUNCTION BOXES SHALL BE OUTDOOR RATED

**SYSTEM**

- 2.1 THE OUTPUT VOLTAGE OF THE OPTIMIZERS ARE REGULATED BY THE INVERTER AND ARE NOT IMPACTED BY THE NUMBER OF MODULES IN THE SUB STRING. THE CONTINUOUS CURRENT OF A SINGLE STRING IS EQUAL TO THE MAXIMUM OUTPUT CURRENT OF THE OPTIMIZER.
- 2.2 THE INVERTER IS EQUIPPED WITH A RAPID SHUTDOWN FEATURE WHICH CONFORMS TO NEC 690.12 WITH SNAP RS DEVICES.
- 2.3 THE INVERTER IS NON-ISOLATED AND UNGROUNDED. NEITHER THE NEGATIVE NOR POSITIVE CONDUCTOR IS GROUNDED AND HAS A COMMON AC AND DC EQUIPMENT GROUNDING TERMINAL THEREFORE NO DC GEC IS REQUIRED.
- 2.4 UTILITY CONNECTION IS MADE ON THE SUPPLY SIDE AS PERMITTED BY 705.11 USING A BREAKER. NB LOADSIDE RULES OF 705.12(B) ARE NOT APPLICABLE.
- 2.5 INTEGRATED DC DISCONNECT AND AFCI IS PROVIDED WITH INVERTER.

**GROUNDING**

- 3.1 ALL EQUIPMENT SHALL BE PROPERLY GROUNDED PER THE REQUIREMENTS OF NEC ARTICLES 250 & 690.
- 3.2 FRAMED PV MODULES SHALL BE BONDED TOGETHER USING LUGS OR RACKING INTEGRATED GROUNDING CLAMPS.
- 3.3 EQUIPMENT GROUNDING SHALL BE INSTALLED PER NEC 250.120(C), SIZED PER 690.45 & BE A MINIMUM OF #6 WHEN EXPOSED TO DAMAGE.
- 3.4 INTERSYSTEM BONDING DEVICE REQUIRED AT SERVICE WHEN COMMUNICATION DEVICES ARE PRESENT PER 250.94.
- 3.5 EXISTING GROUNDING ELECTRODE SYSTEM (GES) SHALL COMPLY WITH 250.64, 250.53 & 250.62 & BE OF THE TYPES & SIZE LISTED IN 250.52.
- 3.6 EXISTING GROUNDING ELECTRODE SYSTEM (GES) SHALL BE SIZED PER 250.66 & T250.66 (FIELD VERIFY).
- 3.7 METAL WATER PIPES SHALL BE GROUNDED PER 250.104(A)

MAKE	REC
MODEL	REC400NP3
RATED POWER (W)	400
MPP VOLTAGE (V)	37.6
MPP CURRENT (A)	10.64
OC VOLTAGE (V)	45
SC CURRENT (A)	11.39

**02 MODULE RATINGS**

MAKE	GENERAC
MODEL	PWRCELL 7.6
MAX INPUT POWER (W)	11800
MAX INPUT VOLTAGE (V)	420
NOM INPUT VOLTAGE (V)	380
MAX INPUT CURRENT (A)	30
NOM AC VOLTAGE (V)	240
MAX AC CURRENT (A)	32
NOM AC POWER (W)	7600

**04 INVERTER RATINGS**

MAKE	GENERAC
MODEL	PV LINK
MPP VOLTAGE	60-360
MAX INPUT VOLTAGE (V)	420
MAX SC CURRENT (A)	18
MAX OUTPUT CURRENT (A)	8
RATED POWER (W)	2500

**03 OPTIMIZER RATINGS**

# PV MODULES	17
STC DC RATING (KW)	6.8
AC OUTPUT RATING (KW)	7.6
# SUBSTRINGS	3
MIN-MAX SUBSTRING SIZE	2-7
DC/AC RATIO	0.89
MPP CURRENT (A)	17.89

**05 SYSTEM**

PV0	(N) PWRCELL 7.6
PV1	(E) 200A, MLO METER-MAIN PNL
PV2	(N) MIN 60A, MANUAL AC DISC

**07 EQUIPMENT SCHEDULE**

**01 NOTES**

ID	RUN	VOLTAGE(V)	CURRENT(A)	VD(%)	LEN(FT)	CONDUCTOR	SIZE	OHM/KFT	CONDUIT	MIN SIZE	#CCC	EGC	OCPD(A)	TERM(C)	TEMP FAC	FILL FAC	BASE AMP	ADJ AMP
A	STR-JBOX	380	8	1	191	PV WIRE	#10	1.24	FREE AIR	NA	2	#6	NA	75	0.96	1	35	35
B	JBOX-INV	380	8	1	191	THHN/THWN-2	#10	1.24	EMT/FMC	3/4"	2	#10	NA	75	0.96	1	35	35
C	INV-DISC	240	32	1	48	THHN/THWN-2	#8	0.778	PVC/EMT/FMC/NMLT	3/4"	3	#10	40	75	0.96	1	50	50
D	DISC-PCC	240	32	1	76	THHN/THWN-2	#6	0.491	PVC/EMT/FMC/NMLT	3/4"	3	#10	60	75	0.96	1	65	65

**06 CONDUCTOR SCHEDULE**

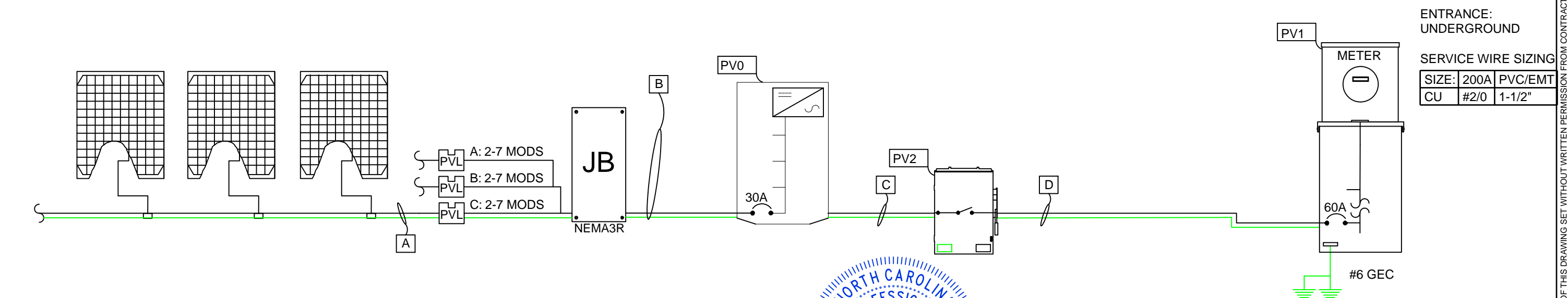

**08 ELECTRICAL LINE DIAGRAM**

BRAD JORDAN 42 BRITISH LANE CAMERON NORTH CAROLINA 28326 UNITED STATES PROJECT ID: 452024-42	CONTRACTOR: LOTUS ENERGY & SOLAR 220 W MAIN ST, TAVARES, FL 32778 (407) 377-7437	ENGINEER: MOHAMED SAID MAHMOUD, PE 8340 LAKE WILLOW WAY, ELK GROVE, CA 95758 MOHAMED SAID MAHMOUD PE056354	DATE: 04.09.24 BY: RG VER: 1	DESCRIPTION: INITIAL DESIGN	E1 PAPER: ARCHB SCALE:
	NORTH CAROLINA PROFESSIONAL SEAL 056354 ENGINEER MOHAMED SAID MAHMOUD				

UNAUTHORIZED USE OF THIS DRAWING SET WITHOUT WRITTEN PERMISSION FROM CONTRACTOR IS IN VIOLATION OF U.S. COPYRIGHT LAWS AND WILL BE SUBJECT TO CIVIL DAMAGES AND PROSECUTIONS

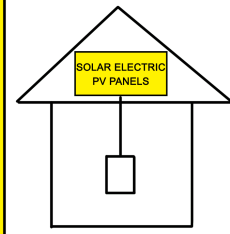
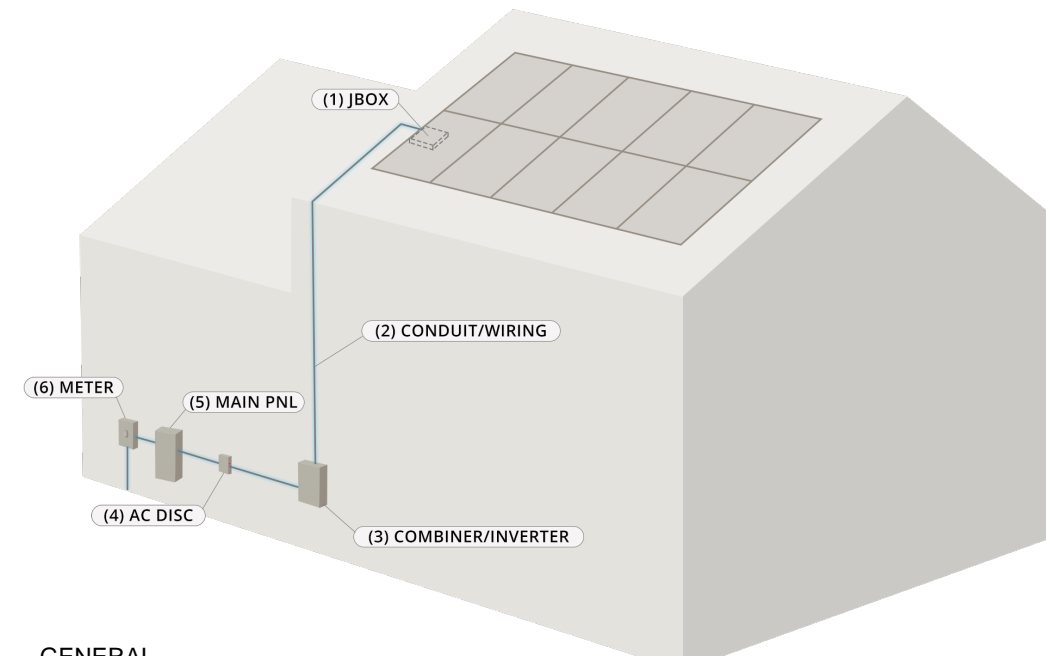
A	<b>WARNING</b>	<p>ELECTRICAL SHOCK HAZARD TERMINALS ON THE LINE AND LOAD SIDES MAY BE ENERGIZED IN THE OPEN POSITION</p> <p>NEC 690.13(B) LOCATION(S): 3, 4</p>							
B	<b>PHOTOVOLTAIC DISCONNECT</b>	<p>NEC 690.13(B) LOCATION(S): 3, 4</p>							
C	<b>WARNING: PHOTOVOLTAIC POWER SOURCE</b>	<p>NFPA 1 11.12.2.1.3, NEC 690.31(G)(3) LOCATION(S): 1, 2</p>	<p><b>CAUTION</b> POWER TO THIS BUILDING IS ALSO SUPPLIED BY SOLAR PANLES WITH DISCONNECTS CO-LOCATED WITH METER</p> <p>NFPA 1 11.12.2.1.4 LOCATION(S): 4, 5</p>						
		<p>SYSTEM SERVICED BY: LOTUS ENERGY &amp; SOLAR (407) 377-7437</p>							
D	<b>WARNING: DUAL POWER SOURCE SECOND SOURCE IS PHOTOVOLTAIC SYSTEM</b>	<p>NEC 705.12(B)(3) LOCATION(S): 5</p>	<p><b>RAPID SHUTDOWN SWITCH FOR SOLAR PV SYSTEM</b></p> <p>NFPA 1 11.12.2.1.1.6, NEC 690.56(C)(3) LOCATION(S): 4</p>						
E	<table border="1" style="width: 100%;"> <tr> <td style="width: 70%;">MAXIMUM VOLTAGE</td> <td style="width: 10%;"></td> <td style="width: 20%; text-align: center;">V</td> </tr> <tr> <td>MAXIMUM CIRCUIT CURRENT</td> <td></td> <td style="text-align: center;">A</td> </tr> </table> <p>NEC 690.54 LOCATION(S): 5</p>	MAXIMUM VOLTAGE		V	MAXIMUM CIRCUIT CURRENT		A	<p><b>SOLAR PV SYSTEM EQUIPPED WITH RAPID SHUTDOWN</b></p> <p>TURN RAPID SHUTDOWN SWITCH TO THE "OFF" POSITION TO SHUT DOWN PV SYSTEM AND REDUCE SHOCK HAZARD IN THE ARRAY</p>  <p>NFPA 1 11.12.2.1.1.1.1, NEC 690.56(C)(1) LOCATION(S): 5</p>	 <p>GENERAL 1.1 LABEL MATERIALS SHALL BE OF SUFFICIENT DURABILITY TO WITHSTAND THE ENVIRONMENT, NEC 110.21(B)(3). 1.2 EXACT MATERIALS USED ARE SUBJECT TO THE REQUIREMENTS OF THE AUTHORITY HAVING JURISDICTION. 1.3 LABELS SHALL BE A MINIMUM LETTER HEIGHT OF 3/8" AND PERMANENTLY AFFIXED. 1.4 LABELS WILL BE REFLECTIVE AND MEET THE REQUIREMENTS OF NFPA 1-11.12.2.1.1.2</p>
MAXIMUM VOLTAGE		V							
MAXIMUM CIRCUIT CURRENT		A							
F	<b>01 LABELS</b>	<b>02 NOTES</b>							

BRAD JORDAN	CONTRACTOR: LOTUS ENERGY & SOLAR 220 W MAIN ST, TAVARES, FL 32778 (407) 377-7437	ENGINEER: MOHAMED SAID MAHMOUD, PE 8340 LAKE WILLOW WAY, ELK GROVE, CA 95758 MOHAMED SAID MAHMOUD PE056354	DATE 04.09.24	BY RG	VER 1	DESCRIPTION INITIAL DESIGN	<b>EL1</b>
42 BRITISH LANE CAMERON NORTH CAROLINA 28326 UNITED STATES							PAPER: ARCHB
PROJECT ID: 452024-42							SCALE:

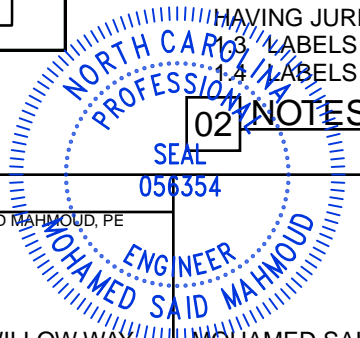

UNAUTHORIZED USE OF THIS DRAWING SET WITHOUT WRITTEN PERMISSION FROM CONTRACTOR IS IN VIOLATION OF U.S. COPYRIGHT LAWS AND WILL BE SUBJECT TO CIVIL DAMAGES AND PROSECUTIONS







REC Solar Pte. Ltd.  
20 Tuas South Avenue 14  
Singapore 637312  
Tel: +65 6495 9228 Fax: +65 6495 9052  
Company registration number: 200723409E  
[www.recgroup.com](http://www.recgroup.com)



REC Solar Pte. Ltd.  
20 Tuas South Avenue 14  
Singapore 637312  
Tel: +65 6495 9228 Fax: +65 6495 9052  
Company registration number: 200723409E  
[www.recgroup.com](http://www.recgroup.com)

MOHAMED SAID MAHMOUD, PE

**IronRidge Inc.**  
28357 Industrial Boulevard  
Hayward, CA 94545

Singapore, January 12, 2023  
REC Reference Number: IDR-23002

To whom it may concern,

**Special approval for the installation of REC N-Peak 3 Black series solar panels using Iron Ridge UFO clamp on Flush, Tilt, and Ground Mount System**

REC herewith grants approval for REC N-Peak 3 Black series solar panels to be installed using Iron Ridge UFO clamp on Flush, Tilt, and Ground Mount System according to the specifications in the table below and in **Appendix A** and **B**:

- The rails are parallel to short side of the panel and clamped on the long side of the frame between 390 and 580 mm from the corner.
- The UFO (Universal Fastening Object) clamp torque value is no less than 80 in-lbs (~9 Nm).
- The panels are not subjected to test loads more than +/- 5400 Pa.

Module	Mounting Configuration	Maximum Allowed Test Load	Design Load (Safety factor of 1.5)
REC N-Peak 3 Black series	Clamp mounted on the long side of the frame as represented in <b>Appendix B</b>	+/- 5400 Pa	+/- 3600 Pa

The terms and conditions as stated in the REC Limited Product Warranty Certificate and REC Installation Manual that are not addressed in this approval remain valid.

Best regards,  
REC Solar Pte. Ltd.

Kay Hwa Wee  
Chief Operating Officer

**Appendix A:**  
Iron Ridge Flush Mount System

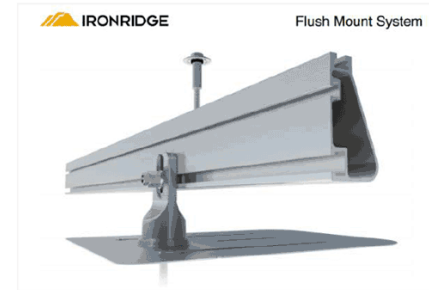

Iron Ridge Ground Mount System



Iron Ridge Tilt Mount System



Iron Ridge UFO clamp



**Appendix B:**  
Mounting configuration of REC N-Peak 3 Black series solar panels using Iron Ridge UFO clamp on Flush, Tilt and Ground Mount System.

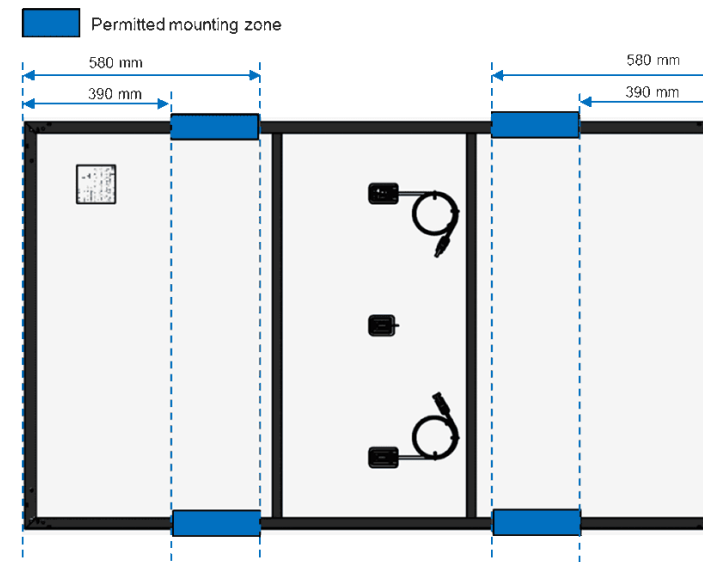

BRAD JORDAN	CONTRACTOR:	ENGINEER:	DATE	BY	VER	DESCRIPTION	D2
	LOTUS ENERGY & SOLAR	MOHAMED SAID MAHMOUD, PE	04.09.24	RG	1	INITIAL DESIGN	
42 BRITISH LANE CAMERON NORTH CAROLINA 28326 UNITED STATES	220 W MAIN ST, TAVARES, FL 32778	8340 LAKE WILLOW WAY, ELK GROVE, CA 95758					PAPER: ARCHB
PROJECT ID: 452024-42	(407) 377-7437	MOHAMED SAID MAHMOUD PE056354					SCALE:

UNAUTHORIZED USE OF THIS DRAWING SET WITHOUT WRITTEN PERMISSION FROM CONTRACTOR IS IN VIOLATION OF U.S. COPYRIGHT LAWS AND WILL BE SUBJECT TO CIVIL DAMAGES AND PROSECUTIONS

**FEATURES:**

- No autotransformer or battery inverter needed
- User-selectable modes
- Free system monitoring



**GENERAC**  
**PWRCELL**

Inverter  
Model: X7602, X11402

Solar-plus-storage is simple with the Generac PWRcell Inverter. This bi-directional, REbus™-powered inverter offers a simple, efficient design for integrating smart batteries with solar. Ideal for self-supply, backup power, zero-export and energy cost management, the PWRcell inverter is the industry's most feature-rich line of inverters, available in single-phase and three-phase models.

**ADDITIONAL FEATURES**

- Single inverter for grid-tied solar with smart battery integration
- Simplified system design: No autotransformer or battery inverter needed
- User-selectable modes for backup power, self-supply, time-of-use and zero-export
- Free system monitoring included via PWRview Web Portal and Mobile App

AC OUTPUT/ GRID-TIE	MODEL X7602	MODEL X11402
RATED AC POWER OUTPUT	7600 W	11400 W
AC OUTPUT VOLTAGE	120/240, 1Ø VAC	120/208, 3Ø VAC
AC FREQUENCY	60 Hz	60 Hz
MAXIMUM CONTINUOUS OUTPUT CURRENT	32 A, RMS	32 A, RMS
GROUND-FAULT ISOLATION DETECTION	Included	Included
CHARGE BATTERY FROM AC	Yes	Yes
THD (CURRENT)	< 2%	< 2%
TYPICAL NIGHTTIME POWER CONSUMPTION	< 7 W	< 7 W

AC OUTPUT/ BACKUP	MODEL X7602	MODEL X11402
RATED AC BACKUP POWER OUTPUT	8000 W	8000 W
MAXIMUM AC BACKUP POWER OUTPUT	12000 W	12000 W
AC BACKUP OUTPUT VOLTAGE	120/240, 1Ø VAC	120/240, 1Ø VAC
AC FREQUENCY	60 HZ	60 HZ
AC CIRCUIT BREAKER	50 A	50 A
THD (VOLTAGE)	< 2%	< 2%
AUTOMATIC SWITCHOVER TIME	< 1 Seconds	< 1 Seconds
TYPICAL NIGHTTIME POWER CONSUMPTION	30 W	30 W

DC INPUT	MODEL X7602	MODEL X11402
DC INPUT VOLTAGE RANGE	360-420 VDC	360-420 VDC
NOMINAL DC BUS VOLTAGE	380 VDC	380 VDC
MAX INPUT CURRENT	20 A	30 A
REVERSE-POLARITY PROTECTION	YES	YES
GROUND-FAULT ISOLATION DETECTION	YES	YES
TRANSFORMERLESS, UNGROUNDED	YES	YES

DC INPUT/ BATTERY	MODEL X7602	MODEL X11402
MAXIMUM CONTINUOUS POWER	8000 W	8000 W
INTERNAL DC DISTRIBUTION BREAKERS	4X 2P30A	4X 2P30A
DC FUSES ON PLUS AND MINUS	40 A	40 A
2-POLE DISCONNECTION	YES	YES

EFFICIENCY	MODEL X7602	MODEL X11402
PEAK EFFICIENCY	97%	98%
CEC WEIGHTED EFFICIENCY	96.5%	97.5%

**Specifications**



**FEATURES AND MODES**

ISLANDING <sup>3</sup>	Yes
GRID SELL	Yes
SELF CONSUMPTION	Yes
PRIORITIZED CHARGING FROM RENEWABLES	Yes
GRID SUPPORT - ZERO EXPORT	Yes

**ADDITIONAL FEATURES**

SUPPORTED COMMUNICATION INTERFACES	CANbus, RS4854, Ethernet
SYSTEM MONITORING	PWRview Web Portal and Mobile App
CRITICAL LOADS DISCONNECT <sup>3</sup>	Yes
MANUAL INVERTER BYPASS SWITCH	Automatic
WARRANTY	10 Years

**STANDARDS COMPLIANCE**

SAFETY	UL1741 SA, CSA 22.2
GRID CONNECTION STANDARDS	IEEE1547, Rule 21, Rule 14H
EMISSIONS	FCC part15 class B

**DIMENSIONS AND INSTALLATION SPECIFICATIONS**

WIRE GAUGE RANGE	10 - 8 AWG
TOTAL AC KNOCKOUTS X SIZE	2" x 0.75"; 2 x 1"
TOTAL DC KNOCKOUTS X SIZE	5" x 1"
DIMENSIONS (L,W,H)	24.5" x 19.25" x 8"
WEIGHT	62.7 lb
COOLING	Forced convection
NOISE	< 40 dBA
OPERATING TEMPERATURE	-20 to 50 °C*
PROTECTION RATING	NEMA 3R

**INSTALLATION GUIDELINES**

BATTERY TYPES SUPPORTED	PWRcell battery module
MODULE STRING SIZE PER PV LINK OPTIMIZER	2-9 PV modules
MAXIMUM RECOMMENDED DC POWER FROM PV	10kW (1Ø), 15kW (3Ø)
BATTERIES PER INVERTER	Up to 2

<sup>3</sup> 3Ø inverters offer islanding for 1Ø loads, <sup>4</sup> Modbus, \*Reduced power at extreme temperatures

Specifications subject to change without notice.



Generac Power Systems, Inc.  
S45 W29290 Hwy. 59, Waukesha, WI 53189  
www.Generac.com 1-888-GENERAC (1-888-436-3722)



Generac Power Systems, Inc.  
S45 W29290 Hwy. 59, Waukesha, WI 53189  
www.Generac.com 1-888-GENERAC (1-888-436-3722)

BRAD JORDAN	CONTRACTOR:	ENGINEER:	DATE	BY	VER	DESCRIPTION	D3
	LOTUS ENERGY & SOLAR	MOHAMED SAID MAHMOUD, PE	04.09.24	RG	1	INITIAL DESIGN	
42 BRITISH LANE CAMERON NORTH CAROLINA 28326 UNITED STATES	220 W MAIN ST, TAVARES, FL 32778 (407) 377-7437	8340 LAKE WILLOW WAY, ELK GROVE, CA 95758	MOHAMED SAID MAHMOUD	PE056354			PAPER: ARCHB
							SCALE:
PROJECT ID: 452024-42							

UNAUTHORIZED USE OF THIS DRAWING SET WITHOUT WRITTEN PERMISSION FROM CONTRACTOR IS IN VIOLATION OF U.S. COPYRIGHT LAWS AND WILL BE SUBJECT TO CIVIL DAMAGES AND PROSECUTIONS

Tech Brief

Tech Brief



### The Respect Your Roof Deserves

When integrating with a home, solar attachments must be dependable for the lifetime of the rooftop. Due to recent innovations, many asphalt shingles have bonded courses. A mount that protects without the need to pry shingles can really speed things up.

Halo UltraGrip™ (HUG™) is here to respect the roof. Its Halo is a cast-aluminum barrier that encases the UltraGrip, our industrial-grade, foam-and-mastic seal. This allows HUG to accelerate the installation process and provide the utmost in waterproofing protection. Give your roof a HUG.™

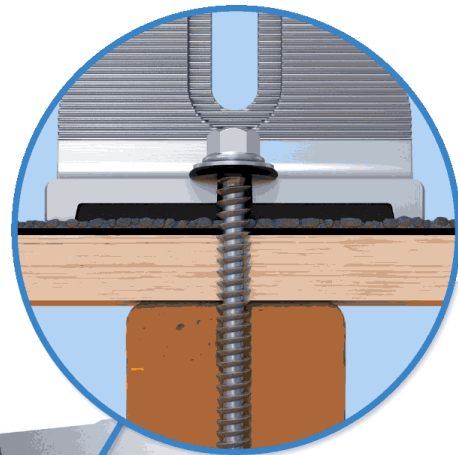

**Multi-Tiered Waterproofing**  
HUG utilizes a multi-tiered stack of components to provide revolutionary waterproofing protection. The Halo cast-aluminum, raised-perimeter foundation surrounds the UltraGrip base—a foam-backed mastic seal combination that prevents water intrusion by adhering and sealing with the shingle surface.

Halo UltraGrip™ is part of the QuickMount® product line.

### UltraGrip™ Seal Technology

HUG UltraGrip utilizes a state-of-the-art seal design that uses a unique, foam-and-mastic combination. The foam-backed adhesive provides an entirely new flashing system that conforms and adheres to every nook and cranny of composition shingles, filling gaps and shingle step-downs (up to 1/8" in height).

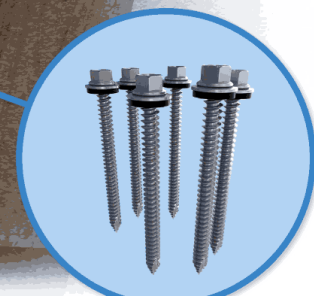
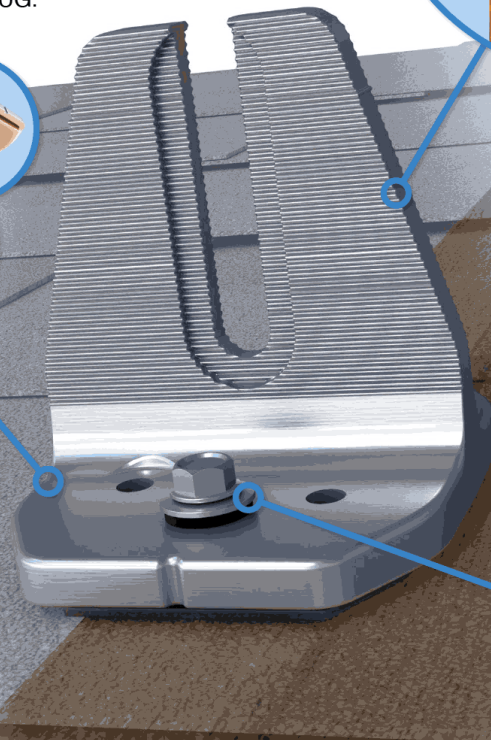

### Rafter & Deck Mounting Options

Mount HUG to the roof rafters, the roof deck, or both with our custom-engineered RD (rafter-or-deck) Structural Screw. The RD Structural Screw anchors HUG to the roof with an EPDM sealing washer, completing the stack of waterproofing barriers. See backside for more installation information.

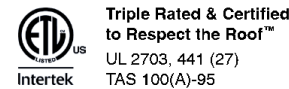

### Adaptive, Rafter-Friendly Installation



**Hit the rafter? Good to go!**  
When you find a rafter, you can move on. Only 2 RD Structural Screws are needed.



**Miss the rafter? Try it again.**  
Place another screw to the left or right. If rafter is found, install 3rd and final screw.



**Still no luck? Install the rest.**  
If more than 3 screws miss the rafter, secure six screws to deck mount it.

### Trusted Strength & Less Hassle

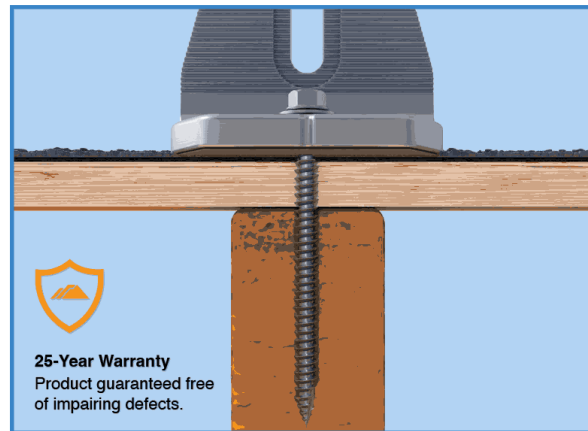

**25-Year Warranty**  
Product guaranteed free of impairing defects.

Structural capacities of HUG™ were reviewed in many load directions, with racking rail running cross-slope or up-slope in relation to roof pitch.

For further details, see the HUG certification letters for attaching to rafters and decking.

IronRidge designed the HUG, in combination with the RD Structural Screw to streamline installs, which means the following:

- No prying shingles
- No roof nail interference
- No pilot holes necessary
- No sealant (in most cases)
- No butyl shims needed

### Attachment Loading

The rafter-mounted HUG has been tested and rated to support 1004 (lbs) of uplift and 368 (lbs) of lateral load.

### Structural Design

Parts are designed and certified for compliance with the International Building Code & ASCE/SEI-7.

### Water Seal Ratings

HUG passed both the UL 441 Section 27 "Rain Test" and TAS 100(A)-95 "Wind Driven Rain Test" by Intertek.

### UL 2703 System

Systems conform to UL 2703 mechanical and bonding requirements. See Flush Mount Manual for more info.

© 2023 IronRidge, Inc. All rights reserved. Visit www.ir-patents.com for patent information. Version 1.02

F	BRAD JORDAN	CONTRACTOR:	ENGINEER:	DATE	BY	VER	DESCRIPTION	D4
	42 BRITISH LANE CAMERON NORTH CAROLINA 28326 UNITED STATES	LOTUS ENERGY & SOLAR 220 W MAIN ST, TAVARES, FL 32778 (407) 377-7437	MOHAMED SAID MAHMOUD, PE 8340 LAKE WILLOW WAY, ELK GROVE, CA 95758	04.09.24	RG	1	INITIAL DESIGN	
	PROJECT ID: 452024-42							PAPER: ARCHB
								SCALE:

UNAUTHORIZED USE OF THIS DRAWING SET WITHOUT WRITTEN PERMISSION FROM CONTRACTOR IS IN VIOLATION OF U.S. COPYRIGHT LAWS AND WILL BE SUBJECT TO CIVIL DAMAGES AND PROSECUTIONS



## XR Rail Family

### Solar Is Not Always Sunny

Over their lifetime, solar panels experience countless extreme weather events. Not just the worst storms in years, but the worst storms in 40 years. High winds capable of ripping panels from a roof, and snowfalls weighing enough to buckle a panel frame.

XR Rails are the structural backbone preventing these results. They resist uplift, protect against buckling and safely and efficiently transfer loads into the building structure. Their superior spanning capability requires fewer roof attachments, reducing the number of roof penetrations and the amount of installation time.

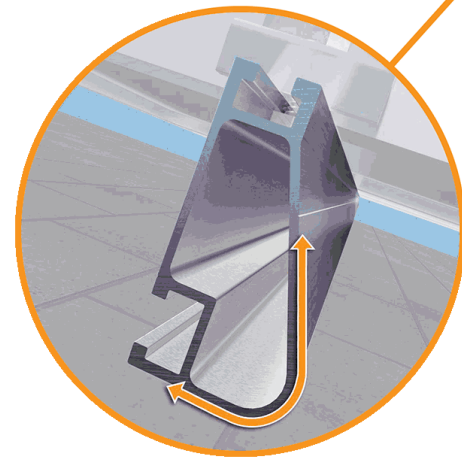
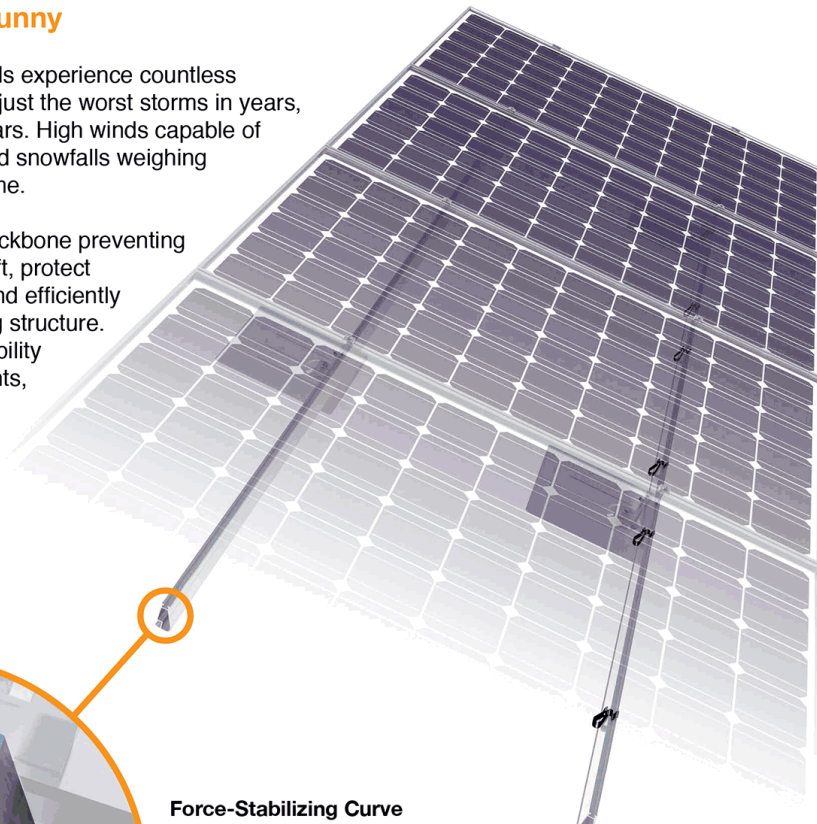

#### Force-Stabilizing Curve

Sloped roofs generate both vertical and lateral forces on mounting rails which can cause them to bend and twist. The curved shape of XR Rails is specially designed to increase strength in both directions while resisting the twisting. This unique feature ensures greater security during extreme weather and a longer system lifetime.

#### Compatible with Flat & Pitched Roofs



XR Rails are compatible with FlashFoot and other pitched roof attachments.



IronRidge offers a range of tilt leg options for flat roof mounting applications.

#### Corrosion-Resistant Materials

All XR Rails are made of marine-grade aluminum alloy, then protected with an anodized finish. Anodizing prevents surface and structural corrosion, while also providing a more attractive appearance.

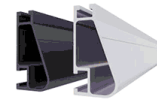

## XR Rail Family

The XR Rail Family offers the strength of a curved rail in three targeted sizes. Each size supports specific design loads, while minimizing material costs. Depending on your location, there is an XR Rail to match.



#### XR10

XR10 is a sleek, low-profile mounting rail, designed for regions with light or no snow. It achieves 6 foot spans, while remaining light and economical.

- 6' spanning capability
- Moderate load capability
- Clear anodized finish
- Internal splices available



#### XR100

XR100 is the ultimate residential mounting rail. It supports a range of wind and snow conditions, while also maximizing spans up to 8 feet.

- 8' spanning capability
- Heavy load capability
- Clear & black anodized finish
- Internal splices available

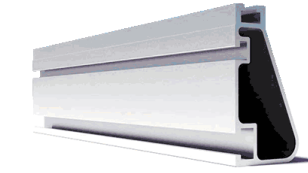

#### XR1000

XR1000 is a heavyweight among solar mounting rails. It's built to handle extreme climates and spans 12 feet or more for commercial applications.

- 12' spanning capability
- Extreme load capability
- Clear anodized finish
- Internal splices available

## Rail Selection

The following table was prepared in compliance with applicable engineering codes and standards. Values are based on the following criteria: ASCE 7-10, Roof Zone 1, Exposure B, Roof Slope of 7 to 27 degrees and Mean Building Height of 30 ft. Visit [IronRidge.com](http://IronRidge.com) for detailed span tables and certifications.

Load		Rail Span					
Snow (PSF)	Wind (MPH)	4'	5' 4"	6'	8'	10'	12'
None	100	XR10		XR100		XR1000	
	120						
	140						
	160						
10-20	100			XR100		XR1000	
	120						
	140						
	160						
30	100			XR100		XR1000	
	160						
40	100			XR100		XR1000	
	160						
50-70	160						
80-90	160						

BRAD JORDAN	CONTRACTOR:	ENGINEER:	DATE	BY	VER	DESCRIPTION	D5
	LOTUS ENERGY & SOLAR	MOHAMED SAID MAHMOUD, PE	04.09.24	RG	1	INITIAL DESIGN	
42 BRITISH LANE CAMERON NORTH CAROLINA 28326 UNITED STATES	220 W MAIN ST, TAVARES, FL 32778 (407) 377-7437	8340 LAKE WILLOW WAY, ELK GROVE, CA 95758	MOHAMED SAID MAHMOUD				PAPER: ARCHB
			PE056354				SCALE:
PROJECT ID: 452024-42							



## UFO Family of Components

### Simplified Grounding for Every Application

The UFO family of components eliminates the need for separate grounding hardware by bonding solar modules directly to IronRidge XR Rails. All system types that feature the UFO family—Flush Mount, Tilt Mount and Ground Mount—are fully listed to the UL 2703 standard.

UFO hardware forms secure electrical bonds with both the module and the rail, resulting in many parallel grounding paths throughout the system. This leads to safer and more reliable installations.

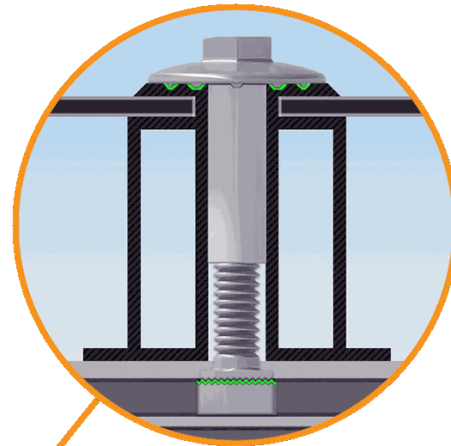

#### Universal Fastening Object (UFO)

The UFO securely bonds solar modules to XR Rails. It comes assembled and lubricated, and can fit a wide range of module heights.

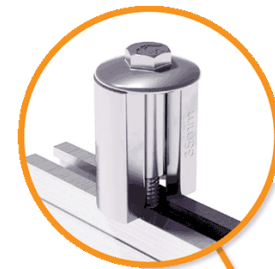

#### Stopper Sleeve

The Stopper Sleeve snaps onto the UFO, converting it into a bonded end clamp.

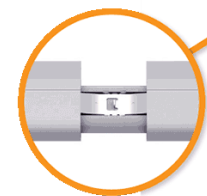

#### BOSS™ Splice

Bonded Structural Splice connects rails with built-in bonding teeth. No tools or hardware needed.

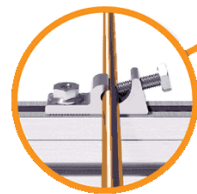

#### Grounding Lug

A single Grounding Lug connects an entire row of PV modules to the grounding conductor.

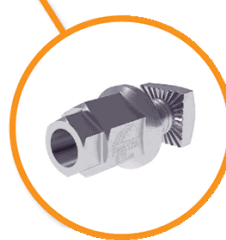

#### Bonded Attachments

The bonding bolt attaches and bonds the L-foot to the rail. It is installed with the same socket as the rest of the system.

### System Diagram

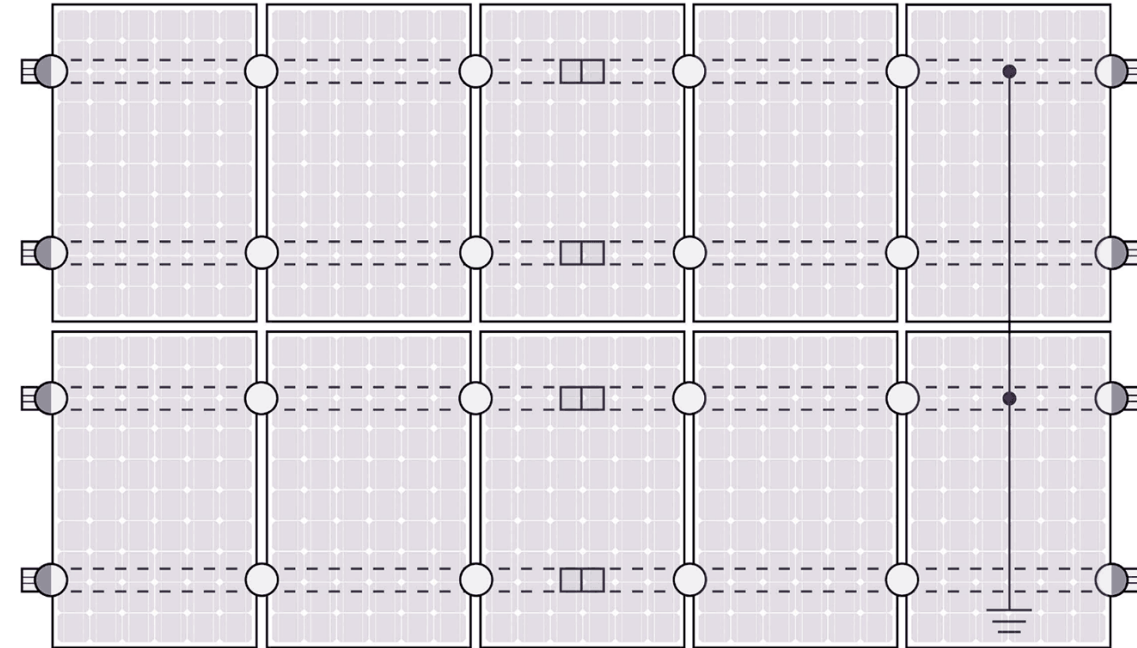

○ UFO    ◐ Stopper Sleeve    ● Grounding Lug    □ BOSS™ Splice    ≡ Ground Wire

⚠ Approved Enphase microinverters can provide equipment grounding of IronRidge systems, eliminating the need for grounding lugs and field installed equipment ground conductors (EGC). A minimum of two microinverters mounted to the same rail and connected to the same Engage cable is required. Refer to installation manuals for additional details.

### UL Certification

The IronRidge Flush Mount, Tilt Mount, and Ground Mount Systems have been listed to UL 2703 by Intertek Group plc.

UL 2703 is the standard for evaluating solar mounting systems. It ensures these devices will maintain strong electrical and mechanical connections over an extended period of time in extreme outdoor environments.

🔗 [Go to IronRidge.com/UFO](https://www.ironridge.com/UFO)

#### Cross-System Compatibility

Feature	Flush Mount	Tilt Mount	Ground Mount
XR Rails	✓	✓	XR1000 Only
UFO/Stopper	✓	✓	✓
BOSS™ Splice	✓	✓	N/A
Grounding Lugs	1 per Row	1 per Row	1 per Array
Microinverters & Power Optimizers	Enphase - M250-72, M250-60, M215-60, C250-72 Darfon - MIG240, MIG300, G320, G640 SolarEdge - P300, P320, P400, P405, P600, P700, P730		
Fire Rating	Class A	Class A	N/A
Modules	Tested or Evaluated with over 400 Framed Modules Refer to installation manuals for a detailed list.		

F	BRAD JORDAN	CONTRACTOR:	ENGINEER:	DATE	BY	VER	DESCRIPTION	D6
	42 BRITISH LANE CAMERON NORTH CAROLINA 28326 UNITED STATES	LOTUS ENERGY & SOLAR 220 W MAIN ST, TAVARES, FL 32778 (407) 377-7437	MOHAMED SAID MAHMOUD, PE 8340 LAKE WILLOW WAY, ELK GROVE, CA 95758	04.09.24	RG	1	INITIAL DESIGN	
	PROJECT ID: 452024-42							PAPER: ARCHB SCALE:

Rail: XR10		Gable Roof Flush Mount System Span Table (inches) - Portrait or Landscape Installation																													
		Max Module Length: 80", Max Module SF: 24 SF																													
		Exposure B																													
Wind Speed (mph)	Roof Slope (deg.)	Ground Snow: 0 psf			10 psf			20 psf			30 psf			40 psf			50 psf			60 psf			70 psf*			80 psf*			90 psf*		
		Group 1	Group 2	Group 3	Group 1	Group 2	Group 3	Group 1	Group 2	Group 3	Group 1	Group 2	Group 3	Group 1	Group 2	Group 3	Group 1	Group 2	Group 3	Group 1	Group 2	Group 3	Group 1	Group 2	Group 3	Group 1	Group 2	Group 3	Group 1	Group 2	Group 3
90 mph	8-20	84	84	83	73	73	73	61	61	61	60	60	60	54	54	54	49	49	49	45	45	45	42	42	42	39	39	39	37	37	37
	21-27	84	84	84	72	72	72	60	60	60	59	59	59	55	55	55	50	50	50	48	48	48	43	43	43	41	41	41	39	39	39
	28-45	84	84	84	72	72	72	60	60	60	59	59	59	55	55	55	51	51	51	49	49	49	48	48	48	43	43	43	41	41	41
95 mph	8-20	84	84	79	73	73	73	61	61	61	60	60	60	54	54	54	49	49	49	45	45	45	42	42	42	39	39	39	37	37	37
	21-27	84	84	84	72	72	72	60	60	60	59	59	59	55	55	55	50	50	50	48	48	48	43	43	43	41	41	41	39	39	39
	28-45	84	84	84	72	72	72	60	60	60	59	59	59	55	55	55	51	51	51	49	49	49	48	48	48	43	43	43	41	41	41
100 mph	8-20	84	82	76	73	73	73	61	61	61	60	60	60	54	54	54	49	49	49	45	45	45	42	42	42	39	39	39	37	37	37
	21-27	84	84	83	72	72	72	60	60	60	59	59	59	55	55	55	50	50	50	48	48	48	43	43	43	41	41	41	39	39	39
	28-45	84	84	84	72	72	72	60	60	60	59	59	59	55	55	55	51	51	51	49	49	49	48	48	48	43	43	43	41	41	41
105 mph	8-20	84	78	72	73	73	72	61	61	61	60	60	60	54	54	54	49	49	49	45	45	45	42	42	42	39	39	39	37	37	37
	21-27	84	84	80	72	72	72	60	60	60	59	59	59	55	55	55	50	50	50	48	48	48	43	43	43	41	41	41	39	39	39
	28-45	84	84	80	72	72	72	60	60	60	59	59	59	55	55	55	51	51	51	49	49	49	48	48	48	43	43	43	41	41	41
110 mph	8-20	84	74	66	73	73	66	61	61	61	60	60	60	54	54	54	49	49	49	45	45	45	42	42	42	39	39	39	37	37	37
	21-27	84	81	76	72	72	72	60	60	60	59	59	59	55	55	55	50	50	50	48	48	48	43	43	43	41	41	41	39	39	39
	28-45	84	84	76	72	72	72	60	60	60	59	59	59	55	55	55	51	51	51	49	49	49	48	48	48	43	43	43	41	41	41
115 mph	8-20	81	72	64	73	72	64	61	61	61	60	60	60	54	54	54	49	49	49	45	45	45	42	42	42	39	39	39	37	37	37
	21-27	84	77	72	72	72	72	60	60	60	59	59	59	55	55	55	50	50	50	48	48	48	43	43	43	41	41	41	39	39	39
	28-45	84	82	73	72	72	72	60	60	60	59	59	59	55	55	55	51	51	51	49	49	49	48	48	48	43	43	43	41	41	41
120 mph	8-20	78	66	59	73	66	59	61	61	59	60	60	59	54	54	54	49	49	49	45	45	45	42	42	42	39	39	39	37	37	37
	21-27	84	73	67	72	72	67	60	60	60	59	59	59	55	55	55	50	50	50	48	48	48	43	43	43	41	41	41	39	39	39
	28-45	84	78	69	72	72	69	60	60	60	59	59	59	55	55	55	51	51	51	49	49	49	48	48	48	43	43	43	41	41	41
130 mph	8-20	72	59	53	72	59	53	61	59	53	60	59	53	54	54	53	49	49	49	45	45	45	42	42	42	39	39	39	37	37	37
	21-27	82	66	60	72	66	60	60	60	60	59	59	59	55	55	55	50	50	50	48	48	48	43	43	43	41	41	41	39	39	39
	28-45	78	72	64	72	64	60	60	60	59	59	59	55	55	55	51	51	51	49	49	49	48	48	48	43	43	43	41	41	41	
140 mph	8-20	65	54	48	65	54	48	61	54	48	60	54	48	54	54	48	49	49	48	45	45	45	42	42	42	39	39	39	37	37	37
	21-27	76	60	55	72	60	55	60	60	55	59	59	55	55	55	55	50	50	50	48	48	48	43	43	43	41	41	41	39	39	39
	28-45	72	65	58	72	65	58	60	60	58	59	59	58	55	55	55	51	51	51	49	49	49	48	48	48	43	43	43	41	41	41
150 mph	8-20	60	49	44	60	49	44	60	49	44	60	49	44	54	49	44	45	45	44	42	42	42	39	39	39	37	37	37	37	37	37
	21-27	72	55	49	72	55	49	60	55	49	59	55	49	55	55	49	50	50	49	48	48	48	43	43	43	41	41	41	39	39	39
	28-45	66	60	53	66	60	53	60	60	53	59	59	53	55	55	53	51	51	51	49	49	49	48	48	48	43	43	43	41	41	41
160 mph	8-20	56	45	40	56	45	40	56	45	40	56	45	40	54	45	40	49	45	40	45	45	40	42	42	40	39	39	39	37	37	37
	21-27	65	51	45	65	51	45	60	51	45	59	51	45	55	51	45	50	50	45	48	48	45	43	43	43	41	41	41	39	39	39
	28-45	61	56	49	61	56	49	60	56	49	59	56	49	55	55	49	51	51	49	48	48	48	48	48	48	43	43	43	41	41	41
170 mph	8-20	52	42	38	52	42	38	52	42	38	52	42	38	52	42	38	49	42	38	45	42	38	42	42	38	39	39	38	37	37	37
	21-27	61	48	42	61	48	42	60	48	42	59	48	42	55	48	42	50	48	42	48	48	42	43	43	42	41	41	41	39	39	39
	28-45	56	52	48	56	52	48	56	52	48	56	52	48	54	52	48	50	50	48	48	48	48	45	45	45	43	43	43	41	41	41
175 mph	8-20	50	41	36	50	41	36	50	41	36	50	41	36	50	41	36	49	41	36	45	41	36	42	41	36	39	39	36	37	37	36
	21-27	59	45	41	59	45	41	59	45	41	59	45	41	55	45	41	50	45	41	48	45	41	43	43	41	41	41	39	39	39	
	28-45	55	50	44	55	50	44	55	50	44	55	50	44	53	50	44	50	50	44	48	48	44	44	44	44	42	42	42	41	41	41
180 mph	8-20	49	39	34	49	39	34	49	39	34	49	39	34	49	39	34	49	39	34	45	39	34	42	39	34	39	39	34	37	37	34
	21-27	57	43	40	57	43	40	57	43	40	57	43	40	55	43	40	50	43	40	48	43	40	43	43	40	41	41	40	39	39	39
	28-45	53	49	42	53	49	42	53	49	42	53	49	42	53	49	42	50	49	42	48	48	42	44	44	42	42	42	42	41	41	41

  = min 72" span    
   = min 64" span    
   = min 48" span    
 \* = Note: additional installation requirement for CAMO modul  
  = Shaded cells indicate conditions in which UFO Mid Clamp connection capacity is exceeded. See Note 9 on page 2 for details.

Grouping of ASCE 7-16 Roof Zones (Gable)						
Roof Slope	8° - 27°			28° - 45°		
Group	Group 1	Group 2	Group 3	Group 1	Group 2	Group 3
ASCE 7-16 Roof Zones	1 2e	2n 2r 3e	3r	1 2e 2r	2n 3r	3e

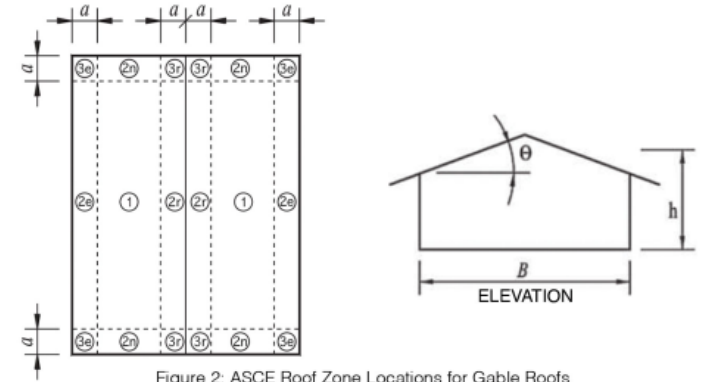

Figure 2: ASCE Roof Zone Locations for Gable Roofs

BRAD JORDAN  42 BRITISH LANE CAMERON NORTH CAROLINA 28326 UNITED STATES  PROJECT ID: 452024-42	CONTRACTOR: LOTUS ENERGY & SOLAR 220 W MAIN ST, TAVARES, FL 32778 (407) 377-7437	ENGINEER: MOHAMED SAID MAHMOUD, PE 8340 LAKE WILLOW WAY, ELK GROVE, CA 95758	DATE: 04.09.24 BY: RG VER: 1	DESCRIPTION: INITIAL DESIGN	D7  PAPER: ARCHB SCALE:	
	MOHAMED SAID MAHMOUD PE056354					

UNAUTHORIZED USE OF THIS DRAWING SET WITHOUT WRITTEN PERMISSION FROM CONTRACTOR IS IN VIOLATION OF U.S. COPYRIGHT LAWS AND WILL BE SUBJECT TO CIVIL DAMAGES AND PROSECUTIONS