

SCOPE OF WORK

TO INSTALL A SOLAR PHOTOVOLTAIC (PV) SYSTEM AT THE COLLINS RESIDENCE, LOCATED AT 728 COLLINS ROAD, LILLINGTON, NORTH CAROLINA. THE POWER GENERATED BY THE PV SYSTEM WILL BE INTERCONNECTED WITH THE UTILITY GRID THROUGH THE EXISTING ELECTRICAL SERVICE EQUIPMENT. THE PV SYSTEM DOES NOT INCLUDE STORAGE BATTERIES.

SYSTEM RATING

8.820 KW DC STC
6.615 KW AC

EQUIPMENT SUMMARY

- (21) REC SOLAR REC420AA PURE-R (420W) PV MODULES
- (21) ENPHASE IQ7X-96-2-US [240V] PV INVERTERS

SHEET INDEX

- PV-0 COVER
- PV-1 SITE MAP AND PV LAYOUT
- PV1A RACKING PLAN
- PV-2 STRING MAP AND MONITORING LAYOUT
- PV-3 ELECTRICAL DIAGRAM
- PV-4 EQ WALL
- PV-5 MOUNTING DETAIL
- PV-6 SYSTEM LABELING DETAIL
- PV-7 SITE DIRECTORY PLACARD
- PV-8 SAFETY PLAN

GOVERNING CODES

2017 NATIONAL ELECTRICAL CODE
2018 NORTH CAROLINA RESIDENTIAL CODE
2018 NORTH CAROLINA STATE BUILDING CODE
UNDERWRITERS LABORATORIES (UL) STANDARDS
OSHA 29 CFR 1910.269

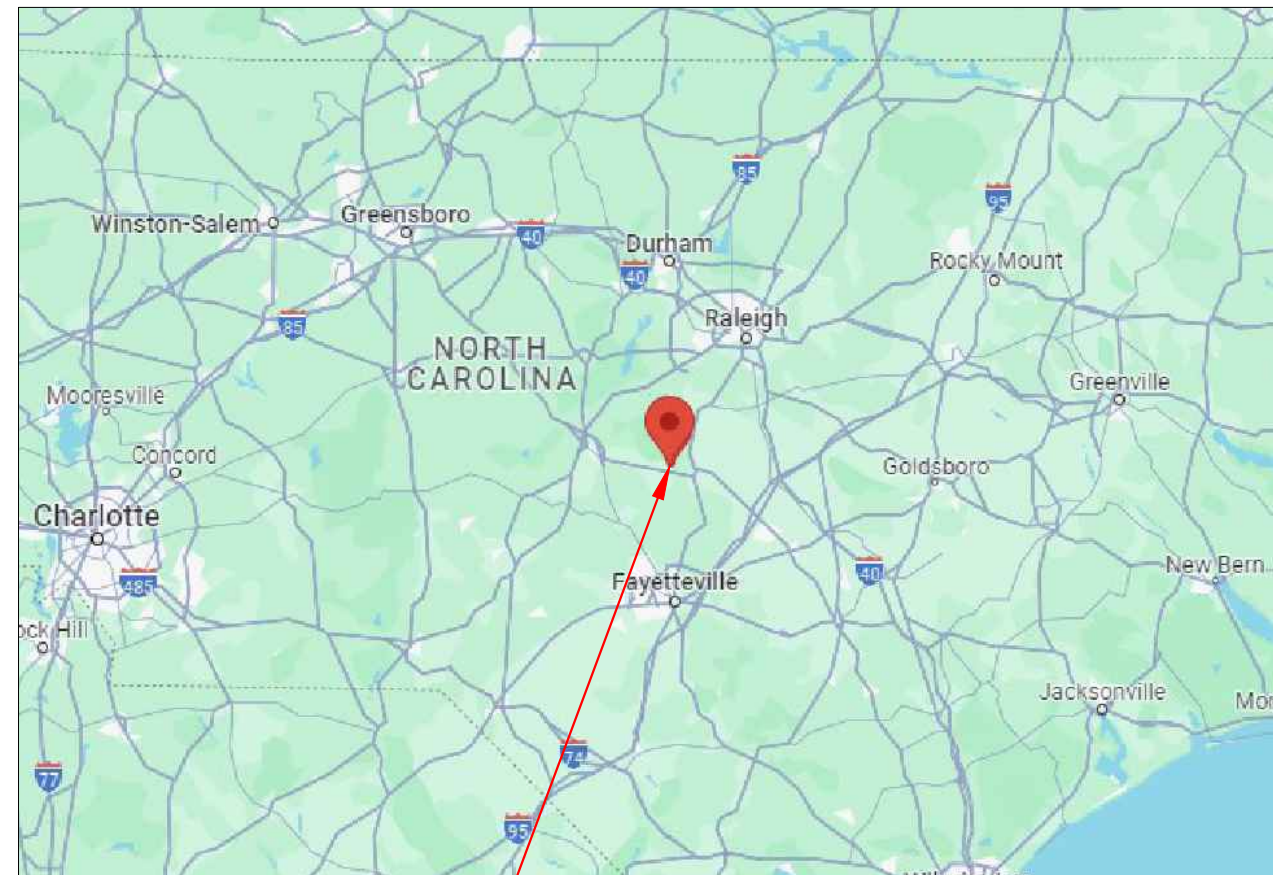

PROJECT LOCATION

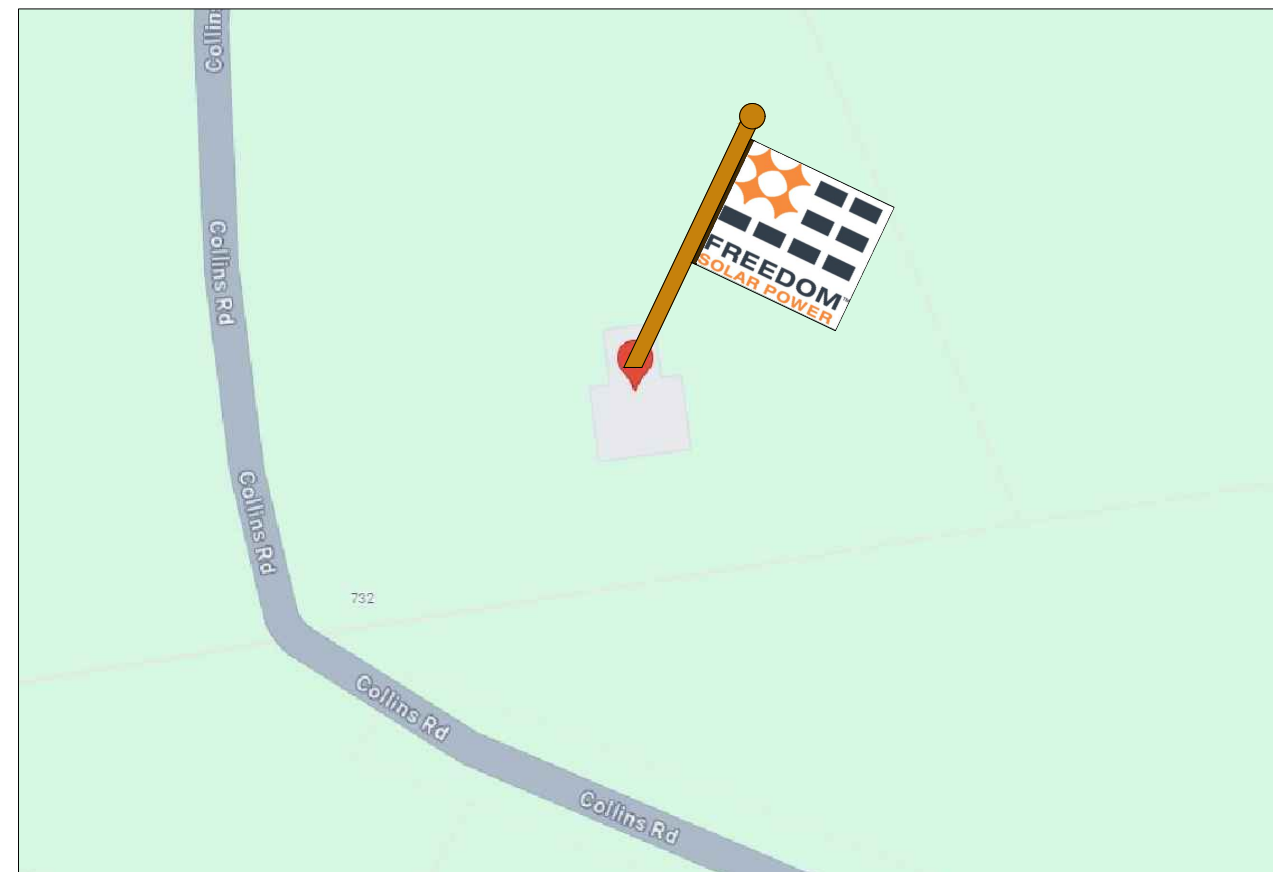

VICINITY MAP

CONTRACTOR



FREEDOMTM
SOLAR POWER

FREEDOM SOLAR LLC
4801 FREDRICH LN, STE 100
AUSTIN, TX 78744
512-759-8313
TECL # 28621

REVISIONS		
DESCRIPTION	DATE	REV
DESIGN PACKET	03/26/2024	

PE STAMP

PROJECT NAME

CURTIS COLLINS
728 COLLINS ROAD
LILLINGTON, NORTH CAROLINA,
27546
(910) 891-8896

SHEET NAME

COVER

SHEET SIZE

ANSI B
11" x 17"

SHEET NUMBER

PV-0

LEAD ID: 114123

CONSTRUCTION SUMMARY

- (21) (REC SOLAR REC420AA PURE-R (420W)) SOLAR MODULES, 8.820 kW DC STC
MODULE DIMENSIONS = 44.0" X 68.1" X 1.2"
- (21) ENPHASE IQ7X-96-2-US [240V] PV INVERTERS
COMBINED INVERTER OUTPUT = 6.615 kW AC.
- RACKING: PEGASUS RAIL
- ATTACHMENT: PEGASUS INSTAFLASH

SITE DETAILS

- ROOF TYPE: ASPHALT SHINGLE
- ARRAY #1 - TILT = 34°, AZIMUTH = 172°
- ARRAY #2 - TILT = 34°, AZIMUTH = 172°
- ARRAY #3 - TILT = 34°, AZIMUTH = 172°
- ARRAY #4 - TILT = 33°, AZIMUTH = 82°

NOTE : PE STAMPS REQUIRED IF:
 -WEIGHT OF ARRAY IS >3PSF
 -MORE THAN 1-LAYER OF SHINGLE
 -ROOF TYPE IS OTHER THAN COMP SHINGLES
 -WIND SPEED IS GREATER THAN 140 MPH

-PANEL WEIGHT EQUALS 2.5 LBS PER SQ FT,
 LESS THAN 3 LBS PER SQ FT

NO CUTTING AND COVERING PLUMBING VENTS AT ALL,
 PVC PIPES CAN BE RELOCATED WITH ROOF JACK

FALL PROTECTION REQUIRED

CONSTRUCTION NOTES

- 1.) ALL EQUIPMENT SHALL BE INSTALLED IN ACCORDANCE WITH THE MANUFACTURER'S INSTALLATION INSTRUCTIONS.
- 2.) ALL OUTDOOR EQUIPMENT SHALL BE RAINTIGHT WITH MINIMUM NEMA 3R RATING.
- 3.) ALL LOCATIONS ARE APPROXIMATE AND REQUIRE FIELD VERIFICATION.

SOUTH RIVER EMC
 REVENUE METER
 #18606349
 GROUNDING ELECTRODE
 METER/MAIN COMBO PANEL
 ENPHASE IQ COMBINER 4
 PV AC DISCONNECT
 -VISIBLE
 -LOCKABLE
 -LABELED
 (OUTSIDE GARAGE WALL)

PV ARRAY #4
 (03) MODULES

PV ARRAY #2
 (06) MODULES

PV ARRAY #1
 (06) MODULES

PV ARRAY #3
 (06) MODULES



CONTRACTOR

**FREEDOM[™]
SOLAR POWER**

FREEDOM SOLAR LLC
 4801 FREDRICH LN, STE 100
 AUSTIN, TX 78744
 512-759-8313
 TECL # 28621

REVISIONS

DESCRIPTION	DATE	REV
DESIGN PACKET	03/26/2024	

PE STAMP

PROJECT NAME

CURTIS COLLINS
 728 COLLINS ROAD
 LILLINGTON, NORTH CAROLINA,
 27546
 (910) 891-8896

SHEET NAME

SITE MAP &
 PV LAYOUT

SHEET SIZE

ANSI B
 11" x 17"

SHEET NUMBER

PV-1

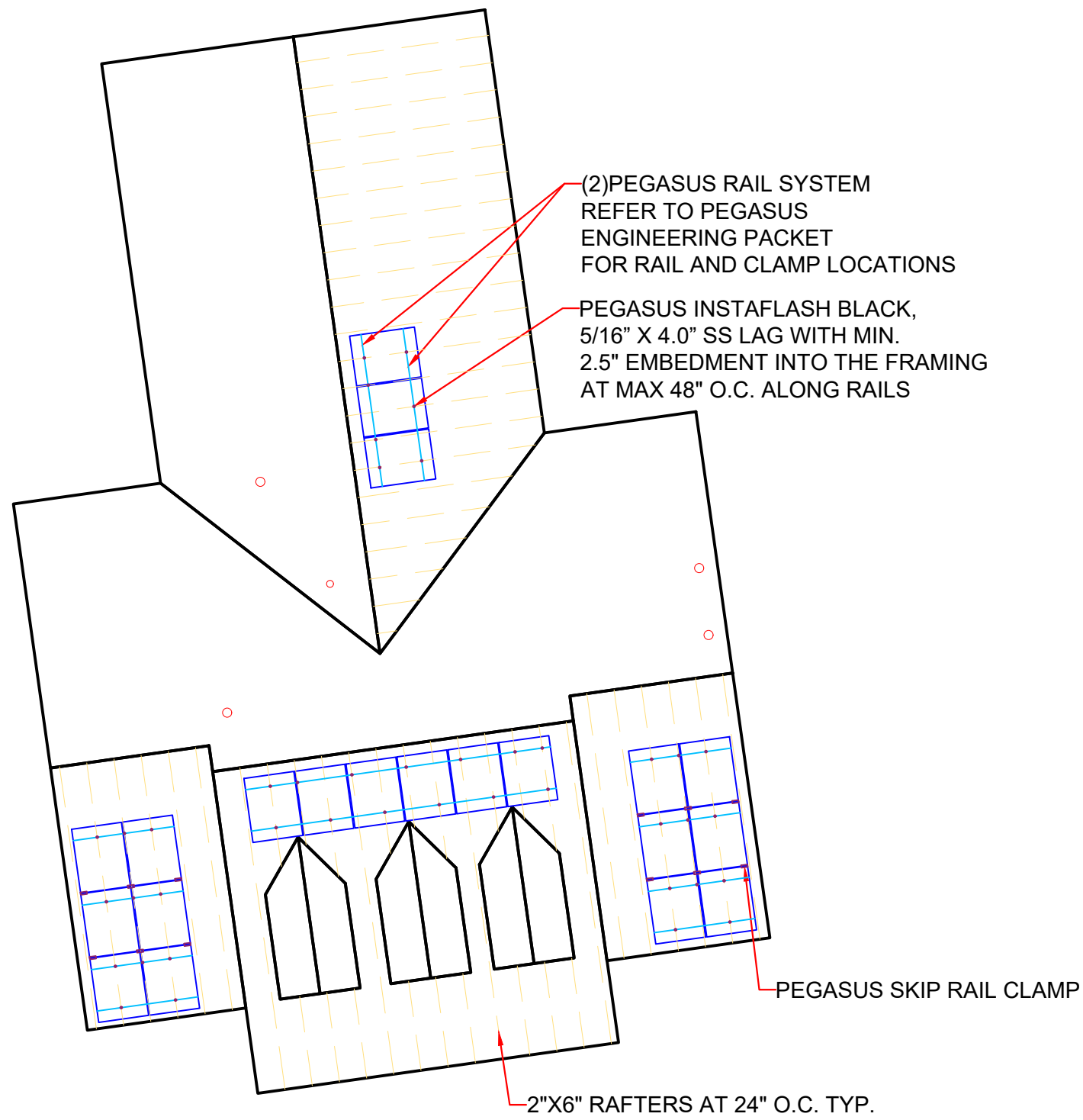

(2) PEGASUS RAIL SYSTEM
REFER TO PEGASUS
ENGINEERING PACKET
FOR RAIL AND CLAMP LOCATIONS

PEGASUS INSTAFLASH BLACK,
5/16" X 4.0" SS LAG WITH MIN.
2.5" EMBEDMENT INTO THE FRAMING
AT MAX 48" O.C. ALONG RAILS

PEGASUS SKIP RAIL CLAMP

2"X6" RAFTERS AT 24" O.C. TYP.

CONSTRUCTION NOTES

- 1.) ALL EQUIPMENT SHALL BE INSTALLED IN ACCORDANCE WITH THE MANUFACTURER'S INSTALLATION INSTRUCTIONS.
- 2.) ALL OUTDOOR EQUIPMENT SHALL BE RAINTIGHT WITH MINIMUM NEMA 3R RATING.
- 3.) ALL LOCATIONS ARE APPROXIMATE AND REQUIRE FIELD VERIFICATION.

CONTRACTOR

**FREEDOMTM
SOLAR POWER**

FREEDOM SOLAR LLC
4801 FREDRICH LN, STE 100
AUSTIN, TX 78744
512-759-8313
TECL # 28621

REVISIONS

DESCRIPTION	DATE	REV
DESIGN PACKET	03/26/2024	

PE STAMP

PROJECT NAME

CURTIS COLLINS
728 COLLINS ROAD
LILLINGTON, NORTH CAROLINA,
27546
(910) 891-8896

SHEET NAME

RACKING PLAN

SHEET SIZE

ANSI B
11" x 17"

SHEET NUMBER

PV-1A

CONTRACTOR



**FREEDOM[™]
SOLAR POWER**

FREEDOM SOLAR LLC
4801 FREIDRICH LN, STE 100
AUSTIN, TX 78744
512-759-8313
TECL # 28621

REVISIONS

DESCRIPTION	DATE	REV
DESIGN PACKET	03/26/2024	

PE STAMP

PROJECT NAME

CURTIS COLLINS
728 COLLINS ROAD
LILLINGTON, NORTH CAROLINA,
27546
(910) 891-8896

SHEET NAME

STRING MAP &
MONITORING
LAYOUT

SHEET SIZE

ANSI B
11" x 17"

SHEET NUMBER

PV-2

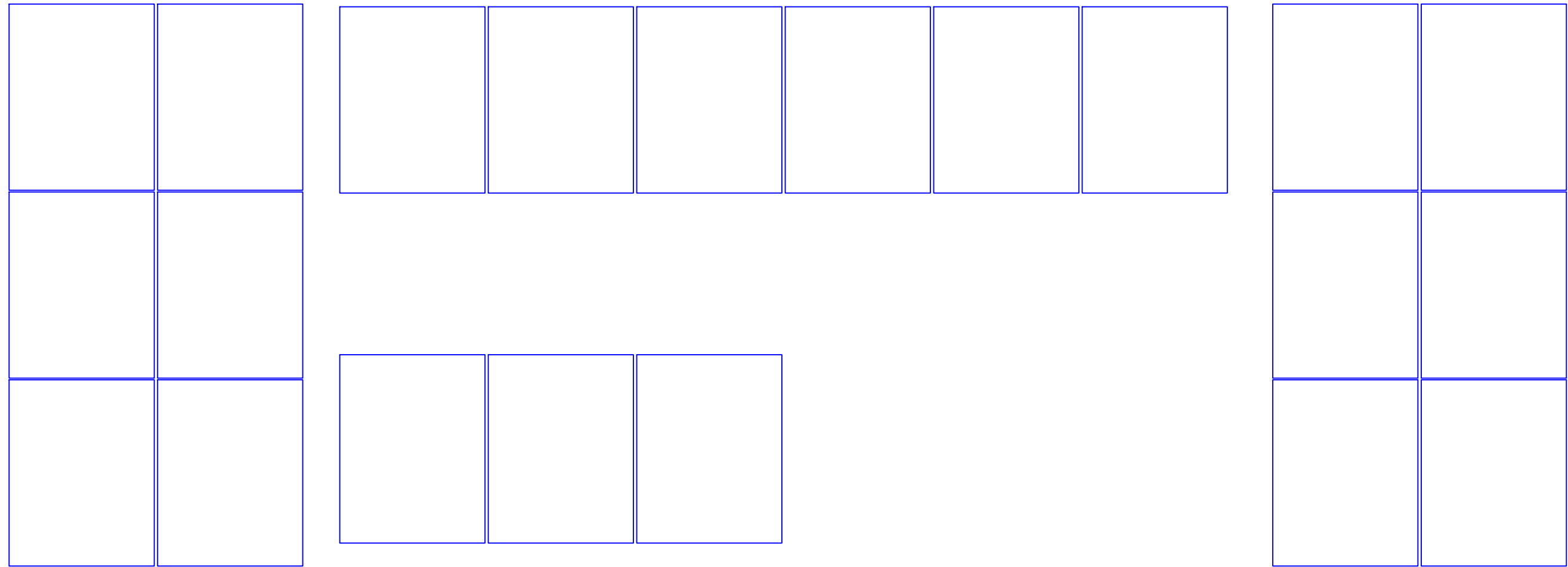

ENPHASE ENVOY S/N _____

SOLAR ARRAY - 8.820 KW DC STC, 6.615 KW AC, 1-PHASE
 (21) REC SOLAR REC420AA PURE-R (420W) PV MODULES
 (21) ENPHASE IQ7X-96-2-US [240V] PV INVERTERS

NEW JUNCTION BOXES:
 TRANSITION FROM Q CABLE
 TO AWG #12 THWN-2
 NEMA 3R, UL LISTED

BRANCH #1

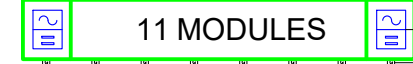

BRANCH #2

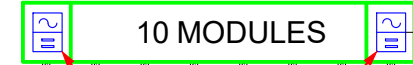

(21) ENPHASE IQ7X-96-2-US [240V]
 INVERTERS 240V AC, 1.31 A MAX
 315 VA, 1-PHASE
 CEC WEIGHTED EFFICIENCY 97.5 %
 NEMA 4R, UL LISTED, INTERNAL GFDI

(1) AWG #6 BARE COPPER
 THWN-2 GND

NEW ENPHASE IQ COMBINER 4
 240VAC, 125A
 NEMA 3R, UL LISTED
 (2) 2P-20A BREAKER
 (1) 2P-10A OR 15A BREAKER

(4) AWG #10 THWN-2
 (1) AWG #10 THWN-2 GND
 IN 3/4" CONDUIT OR
 (ROMEX 10/2 IN ATTIC)

NEW PV AC DISCONNECT
 240VAC, 60A
 NON FUSIBLE,
 NEMA 3R, UL LISTED
 VISIBLE, LOCKABLE, LABELED

(3) AWG #8 THWN-2
 (1) AWG #8 THWN-2 GND
 IN 1" CONDUIT

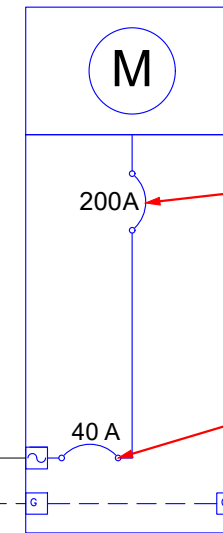

SOUTH RIVER EMC
 REVENUE METER
 #18606349
 1-PHASE, 3 WIRE, 240V

MAIN SERVICE DISCONNECT
 240V, 200A

METER/MAIN COMBO PANEL
 SIEMENS, 1P3W
 240V, 200A BUS

POINT OF INTERCONNECTION
 (1) 2P-40A CIRCUIT BREAKER
 INSTALLED AT OPPOSITE END OF
 BUS FROM MAIN DISCONNECT

EXISTING GROUNDING
 ELECTRODE SYSTEM

ELECTRICAL NOTES

- 1.) ALL EQUIPMENT TO BE LISTED BY UL OR OTHER NRTL, AND LABELED FOR ITS APPLICATION.
- 2.) ALL CONDUCTORS SHALL BE COPPER. ALUMINUM CONDUCTORS MAY BE USED IF CORRECTLY UPSIZED FOR AMPACITY RATING PER NEC 310.12 OR 310.16. ALL CONDUCTORS SHALL BE RATED FOR 600V AND 90°C WET ENVIRONMENT UNLESS OTHERWISE NOTED.
- 3.) WORKING CLEARANCES AROUND ALL NEW AND EXISTING ELECTRICAL EQUIPMENT SHALL COMPLY WITH NEC 110.26.
- 4.) DRAWINGS INDICATE THE GENERAL ARRANGEMENT OF SYSTEMS. CONTRACTOR SHALL FURNISH ALL NECESSARY OUTLETS, SUPPORTS, FITTINGS AND ACCESSORIES TO FULFILL APPLICABLE CODES AND STANDARDS.
- 5.) WHERE SIZES OF JUNCTION BOXES, RACEWAYS, AND CONDUITS ARE NOT SPECIFIED, THE CONTRACTOR SHALL SIZE THEM ACCORDINGLY. SPECIFIED CONDUIT AND WIRE SIZES ARE MINIMUM REQUIREMENTS AND LARGER SIZES SHALL BE PERMITTED.
- 6.) ALL WIRE TERMINATIONS SHALL BE APPROPRIATELY LABELED AND READILY VISIBLE.
- 7.) MAXIMUM MOUNTING HEIGHT FROM GRADE TO CENTER OF METER SOCKET SHALL BE 72" FOR RESIDENTIAL SINGLE PHASE METER SOCKETS 0-320 AMPS. MINIMUM MOUNTING HEIGHT IS 30" FROM GRADE FOR AUSTIN ENERGY, AND 48" FOR ALL OTHER JURISDICTIONS
- 8.) MINIMUM HORIZONTAL CLEARANCE FROM GAS REGULATOR TO ANY ELECTRICAL ENCLOSURE IS 36", EXCEPT AUSTIN ENERGY WHICH REQUIRES 48" CLEARANCE FROM GAS TO METER SOCKET
- 9.) PV DISCONNECT SHALL BE VISIBLE, LOCKABLE AND LABELED AND THE DOOR CANNOT BE OPENED WHEN HANDLE IS IN ON POSITION
- 10.) BY DEFAULT THE MONITORING DEVICE IS SHOWN CONNECTED TO A 20-AMP BREAKER IN THE SOLAR LOAD CENTER. ALTERNATIVELY, THE MONITORING DEVICE MAY BE CONNECTED TO A 20-AMP BREAKER AT THE MAIN DISTRIBUTION PANEL.
- 11.) ALL EQUIPMENT TERMINATIONS SHALL BE RATED FOR 75 DEGREES OR GREATER
- 12.) ALL CT WIRES SHALL BE CONSIDERED CLASS 1 PER NEC ARTICLE 725, AND BE MARKED AS RATED FOR 600V. PER 725.48(A) CLASS 1 CIRCUITS SHALL BE PERMITTED TO OCCUPY THE SAME RACEWAY AS OTHER CIRCUITS PROVIDED ALL CONDUCTORS ARE INSULATED FOR THE MAXIMUM VOLTAGE OF ANY CONDUCTOR IN THE RACEWAY.
- 13.) AWG #10 COPPER CONDUCTORS ARE SPECIFIED AS THE DEFAULT WIRE REQUIRED FROM THE PV ARRAY TO THE SOLAR LOAD CENTER, HOWEVER, AWG #12 COPPER CONDUCTORS MAY BE UTILIZED IF BOTH OF THE FOLLOWING CONDITIONS ARE MET: THE LENGTH OF THE CONDUCTOR IS LESS THAN 75 FT AND THERE ARE LESS THAN 8 CURRENT-CARRYING CONDUCTORS WITHIN THE RACEWAY.

CALCULATIONS FOR CURRENT CARRYING CONDUCTORS	CALCULATIONS FOR OVERCURRENT DEVICES
<p>INVERTER OUTPUT WIRE AMPACITY CALCULATION [NEC 690.8(A)(3)]: 1.31A PER INVERTER ENPHASE IQ7X-96-2-US [240V] MAXIMUM INVERTER BRANCH CURRENT = (12)(1.31A) = 15.72A CONTINUOUS USE: #10 WIRE 75°C DERATED AMPACITY = (0.80)(35.0A) = 28.00A 28.00A > 15.72A CONDITIONS OF USE: #10 WIRE 90°C DERATED AMPACITY = (0.91)(0.80)(40.0A) = 29.12A 29.12A > 15.72A</p> <p>ENPHASE IQ COMBINER 4 OUTPUT WIRE AMPACITY CALCULATION [NEC 690.8(A)(3)]: 1.31A PER INVERTER ENPHASE IQ7X-96-2-US [240V] COMBINED CURRENT = (21)(1.31A) = 27.51A CONTINUOUS USE: #8 WIRE 75°C DERATED AMPACITY = (0.80)(50A) = 40.00A 40.00A > 27.51A CONDITIONS OF USE: #8 WIRE 90°C DERATED AMPACITY = (0.91)(55A) = 50.05A 50.05A > 27.51A</p>	<p>INVERTER BRANCH AC CURRENT CALCULATION [NEC 690.8(A)(3)]: 1.31A PER INVERTER ENPHASE IQ7X-96-2-US [240V] MAXIMUM BRANCH INVERTER CURRENT = (12)(1.31A) = 15.72A MINIMUM OCPD = (15.72A)(1.25) = 19.65A USE 2P-20A BREAKERS IN ENPHASE IQ COMBINER 4 FOR INVERTER BRANCH OCPD</p> <p>SYSTEM AC CURRENT CALCULATION [NEC 690.8(A)(3)]: 1.31A PER INVERTER ENPHASE IQ7X-96-2-US [240V] COMBINED CURRENT = (21)(1.31A) = 27.51A MINIMUM OCPD = (27.51A)(1.25) = 34.39A USE 2P-40A BREAKER IN METER/MAIN FOR SYSTEM OCPD</p>

CONTRACTOR

FREEDOM[™]
SOLAR POWER

FREEDOM SOLAR LLC
 4801 FREIDRICH LN, STE 100
 AUSTIN, TX 78744
 512-759-8313
 TECL # 28621

REVISIONS		
DESCRIPTION	DATE	REV
DESIGN PACKET	03/26/2024	

PE STAMP

PROJECT NAME

CURTIS COLLINS
728 COLLINS ROAD
LILLINGTON, NORTH CAROLINA,
27546
(910) 891-8896

SHEET NAME

**ELECTRICAL
 DIAGRAM**

SHEET SIZE

**ANSI B
 11" x 17"**

SHEET NUMBER

PV-3

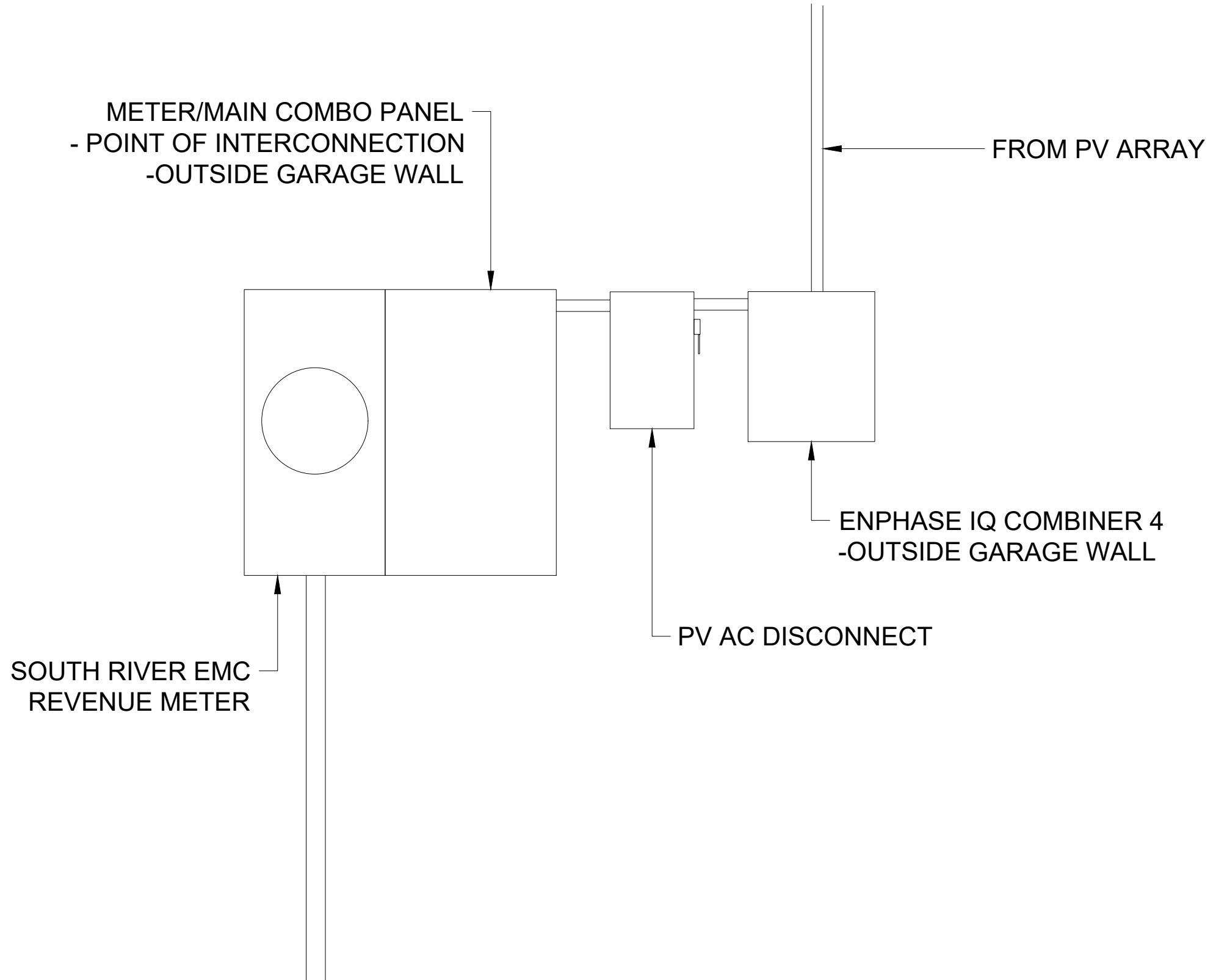

CONTRACTOR



**FREEDOM™
SOLAR POWER**

FREEDOM SOLAR LLC
4801 FREIDRICH LN, STE 100
AUSTIN, TX 78744
512-759-8313
TECL # 28621

REVISIONS

DESCRIPTION	DATE	REV
DESIGN PACKET	03/26/2024	

PE STAMP

PROJECT NAME

CURTIS COLLINS
728 COLLINS ROAD
LILLINGTON, NORTH CAROLINA,
27546
(910) 891-8896

SHEET NAME

EQ.WALL

SHEET SIZE

ANSI B
11" x 17"

SHEET NUMBER

PV-4

CONTRACTOR



**FREEDOM[™]
SOLAR POWER**

FREEDOM SOLAR LLC
4801 FREIDRICH LN, STE 100
AUSTIN, TX 78744
512-759-8313
TECL # 28621

REVISIONS

DESCRIPTION	DATE	REV
DESIGN PACKET	03/26/2024	

PE STAMP

PROJECT NAME

CURTIS COLLINS
728 COLLINS ROAD
LILLINGTON, NORTH CAROLINA,
27546
(910) 891-8896

SHEET NAME

MOUNTING DETAIL

SHEET SIZE

**ANSI B
11" x 17"**

SHEET NUMBER

PV-5

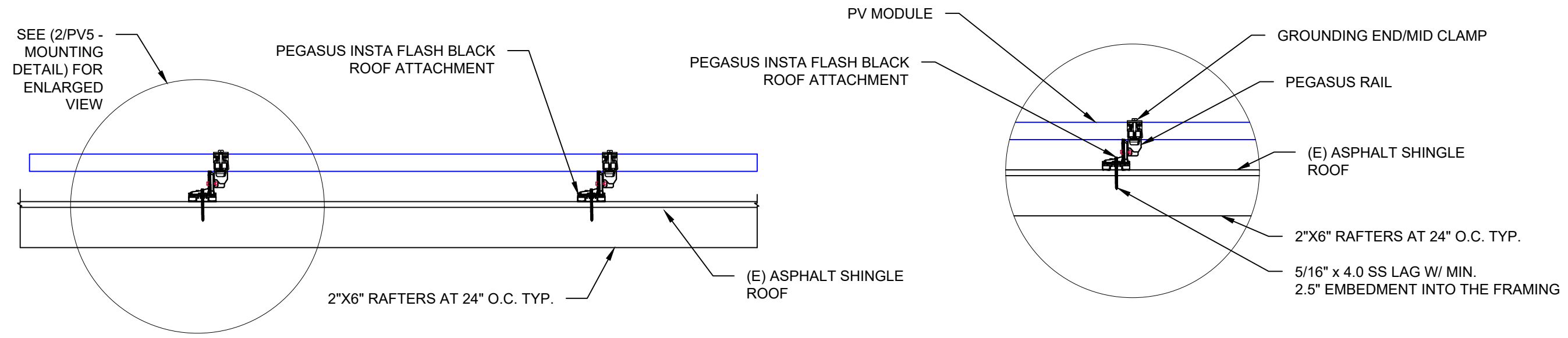

MOUNTING METHOD
NTS

1

MOUNTING DETAIL
NTS

2

NOTE: NOT ALL LABELS MAY BE APPLICABLE

SIGNAGE REQUIREMENTS

- > RED BACKGROUND
- > WHITE LETTERING
- > MIN. 3/8" LETTER HEIGHT
- > ALL CAPITAL LETTERS
- > ARIAL OR SIMILAR FONT
- > REFLECTIVE, WEATHER RESISTANT MATERIAL, UL 969

CONTRACTOR



FREEDOM SOLAR POWER
 FREEDOM SOLAR LLC
 4801 FREDRICH LN, STE 100
 AUSTIN, TX 78744
 512-759-8313
 TECL # 28621

REVISIONS

DESCRIPTION	DATE	REV
DESIGN PACKET	03/26/2024	

PE STAMP

PROJECT NAME

CURTIS COLLINS
 728 COLLINS ROAD
 LILLINGTON, NORTH CAROLINA,
 27546
 (910) 891-8896

SHEET NAME

SYSTEM LABELING DETAIL

SHEET SIZE

ANSI B
 11" x 17"

SHEET NUMBER

PV-6

WARNING
 ELECTRIC SHOCK HAZARD.
 DO NOT TOUCH TERMINALS.
 TERMINALS ON THE LINE AND
 LOAD SIDES MAY BE
 ENERGIZED IN THE OPEN
 POSITION.

WARNING: PHOTOVOLTAIC
 POWER SOURCE

WARNING
 POWER SOURCE OUTPUT
 CONNECTION. DO NOT
 RELOCATE THIS
 OVERCURRENT DEVICE

PV SYSTEM DISCONNECT

REQ'D BY: NEC 690.13(B) A
 APPLY TO:
 PV DISCONNECT

REQ'D BY: NEC 690.13(B) B
 APPLY TO:
 PV DISCONNECT

REQ'D BY: NEC 690.31(G)(3) C
 APPLY TO:
 RACEWAYS, CABLE TRAYS,
 OTHER WIRING METHODS, AND
 ENCLOSURES THAN CONTAIN
 PV SYSTEM DC CONDUCTORS

REQ'D BY: NEC 705.12(B)(2)(3)(b) D
 APPLY TO:
 DISTRIBUTION EQUIPMENT
 ADJACENT TO BACK-FED BREAKER

2" ADDRESS NUMBERS

REQ' BY: AHJ E
 APPLY TO:
 REVENUE METER SOCKET
 (IF APPLICABLE)

REVENUE METER

REQ'D BY: AHJ F
 APPLY TO:
 REVENUE METER SOCKET
 (IF APPLICABLE)

MONITORING

REQ'D BY: FREEDOM SOLAR G
 APPLY TO:
 MONITORING DEVICE ENCLOSURE

RAPID SHUTDOWN SWITCH
 FOR SOLAR PV SYSTEM

REQ'D BY: NEC 690.56(C)(2) H
 APPLY TO:
 PV DISCONNECT

PHOTOVOLTAIC SYSTEM
 AC DISCONNECT
 OPERATING CURRENT: 27.51A
 OPERATING VOLTAGE: 240 VAC

REQ'D BY: 690.56(1)(a) I
 APPLY TO:
 PV DISCONNECT

SOLAR PV SYSTEM EQUIPPED
 WITH RAPID SHUTDOWN

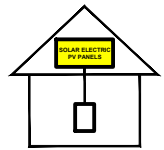

TURN RAPID SHUTDOWN SWITCH TO THE "OFF" POSITION TO SHUT DOWN PV SYSTEM AND REDUCE SHOCK HAZARD IN THE ARRAY.

REQ'D BY: FREEDOM SOLAR J
 APPLY TO:
 MAIN DISTRIBUTION PANEL

CAUTION

POWER TO THIS BUILDING IS ALSO SUPPLIED FROM THE FOLLOWING SOURCES WITH DISCONNECTS AS SHOWN:

UTILITY SUPPLY & CUSTOMER SERVICE PANEL

PV AC DISCONNECT

RAPID SHUTDOWN SWITCH

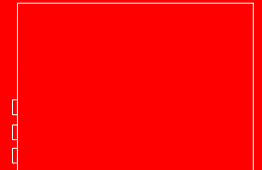

FRONT

REQ'D BY: 705.10 K
 APPLY TO:
 MAIN DISTRIBUTION PANEL
 (*ONLY REQUIRED IF PV SYSTEM DISCONNECT IS NOT GROUPED WITH MAIN SERVICE DISCONNECT)
SEE SHEET PV-6 FOR SITE SPECIFIC LABELS

CAUTION:
MULTIPLE SOURCES OF POWER
LOCATION OF EACH POWER SOURCE
DISCONNECTING MEANS SHOWN BELOW

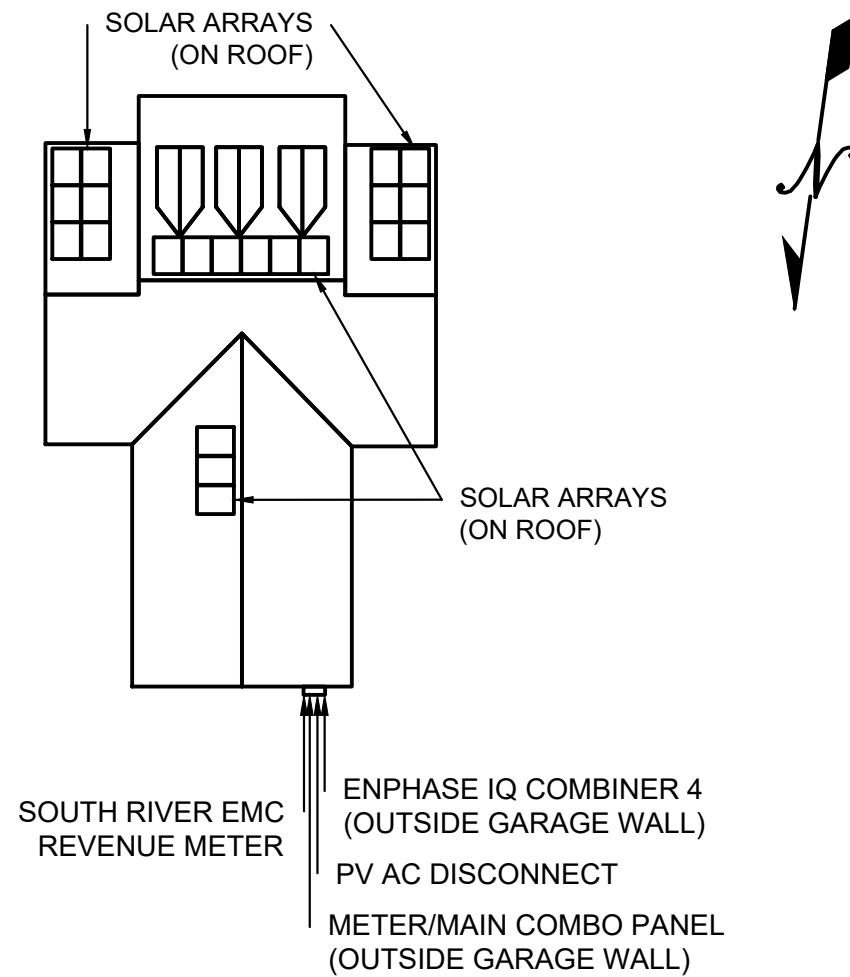

QUESTIONS, CALL:
 800-504-2337
www.freedomsolarpower.com



CONTRACTOR

FREEDOM
SOLAR POWER
 FREEDOM SOLAR LLC
 4801 FREDRICH LN, STE 100
 AUSTIN, TX 78744
 512-759-8313
 TECL # 28621

REVISIONS

DESCRIPTION	DATE	REV
DESIGN PACKET	03/26/2024	

PE STAMP

PROJECT NAME

CURTIS COLLINS
 728 COLLINS ROAD
 LILLINGTON, NORTH CAROLINA,
 27546
 (910) 891-8896

SHEET NAME

SITE
 DIRECTORY
 PLACARD

SHEET SIZE

ANSI B
 11" x 17"

SHEET NUMBER

PV-7

USE THE SAFETY SYMBOL KEY TO DRAW IN THE CONTROLLED ACCESS ZONE (CAZ), LADDER PLACEMENT, METER LOCATION, FALL PROTECTION ANCHOR POINT, AND ANY OTHER HAZARD.

HARD HAT IS REQUIRED AT ALL TIMES IN CAZ

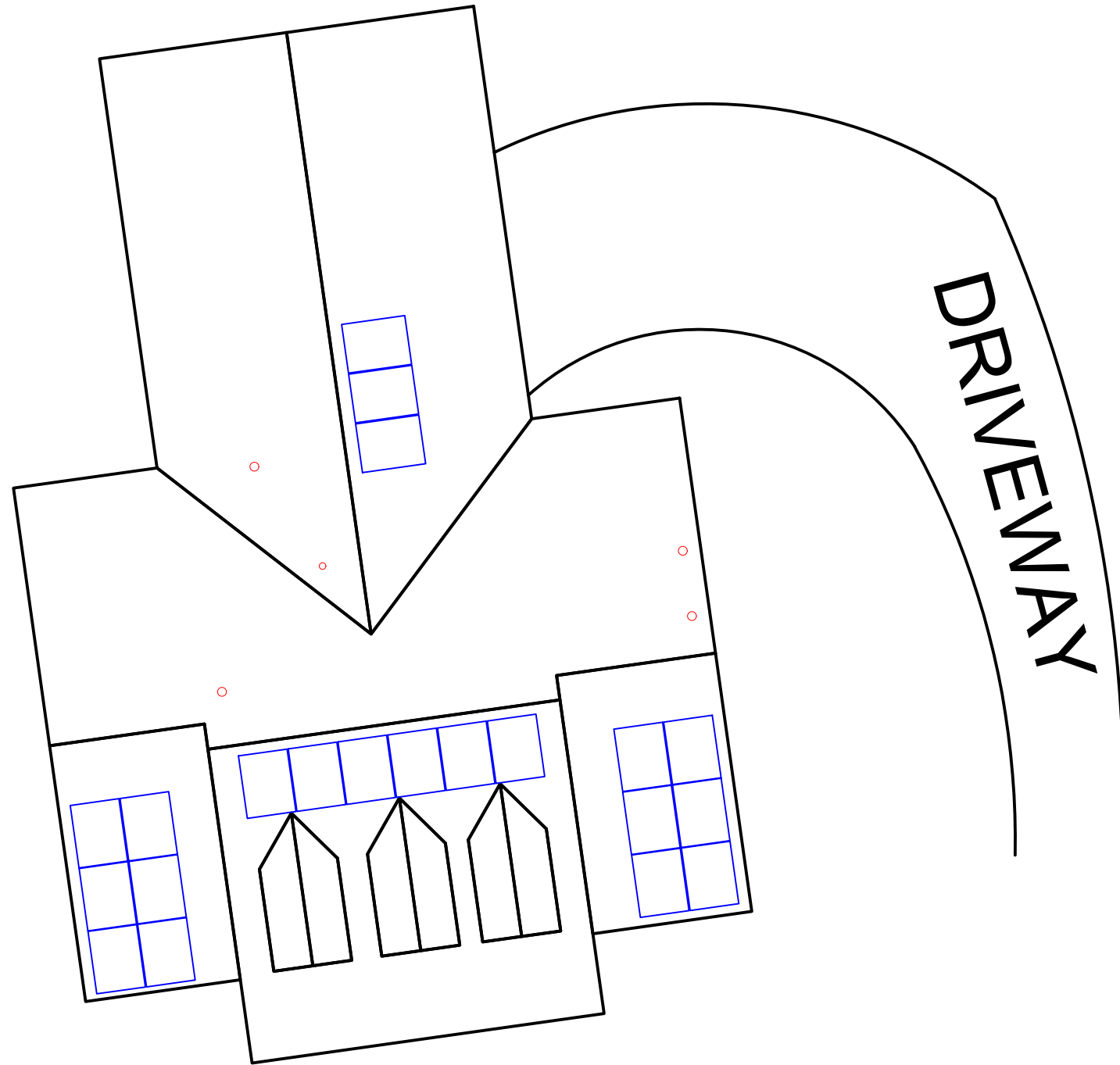

SAFETY SYMBOL KEY

- CAZ
- L** LADDER
- M** METER
- ==== POWER LINES
- R** RESTRAINT ANCHOR
- A** ARREST ANCHOR



CONTRACTOR

FREEDOM SOLAR POWER
 FREEDOM SOLAR LLC
 4801 FREDRICH LN, STE 100
 AUSTIN, TX 78744
 512-759-8313
 TECL # 28621

REVISIONS

DESCRIPTION	DATE	REV
DESIGN PACKET	03/26/2024	

PE STAMP

CONDUCT SAFETY MEETING WITH ALL CREW MEMBERS ON SITE AT THE BEGINNING OF EACH JOB. USE SIGN IN SHEET BELOW.

1. _____
2. _____
3. _____
4. _____
5. _____

PROJECT NAME

CURTIS COLLINS
 728 COLLINS ROAD
 LILLINGTON, NORTH CAROLINA, 27546
 (910) 891-8896

SHEET NAME

SAFETY PLAN

SHEET SIZE

ANSI B
 11" x 17"

SHEET NUMBER

PV-8

COMPETENT PERSON: _____ JOB START DATE: _____

SOLAR'S MOST TRUSTED



REC ALPHA PURE-R SERIES

PRODUCT SPECIFICATIONS

COMPACT PANEL SIZE

9 A MODULE CURRENT COMPATIBLE WITH MLPE

430 WP
20.7 W/FT²
22.3% EFFICIENCY



REC ALPHA PURE-R SERIES

PRODUCT SPECIFICATIONS



GENERAL DATA

Cell type:	80 half-cut REC bifacial, heterojunction cells with lead-free, gapless technology
Glass:	0.13in (3.2mm) solar glass with anti-reflective surface treatment in accordance with EN 12150
Backsheet:	Highly resistant polymer (black)
Frame:	Anodized aluminum (black)
Junction box:	4-part, 4 bypass diodes, lead-free IP68 rated, in accordance with IEC 62790
Connectors:	Stäubli MC4 PV-KBT4/KST4 (12 AWG) in accordance with IEC 62852, IP68 only when connected
Cable:	12 AWG (4mm ²) PV wire, 67 + 67 in (1.7 + 1.7 m) in accordance with EN 50618
Dimensions:	68.1 x 44.0 x 1.2 in (20.77 ft ²) / 1730 x 1118 x 30 mm (1.93 m ²)
Weight:	47.4 lbs (21.5 kg)
Origin:	Made in Singapore

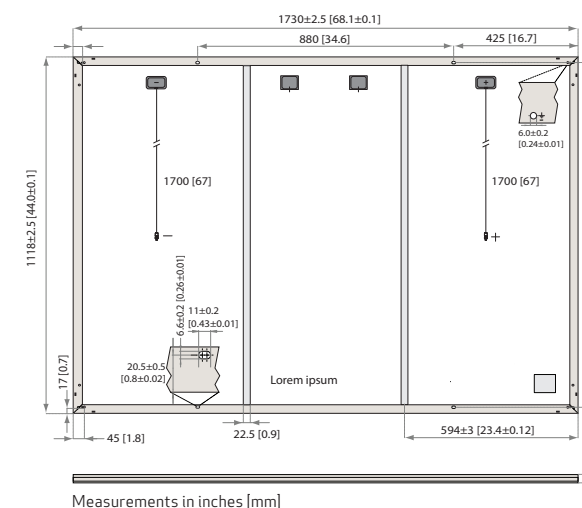

ELECTRICAL DATA

Product Code*: RECxxxAA PURE-R

STC

Power Output - P _{MAX} (Wp)	400	410	420	430
Watt Class Sorting - (W)	0/+10	0/+10	0/+10	0/+10
Nominal Power Voltage - V _{MPP} (V)	48.8	49.4	50.0	50.5
Nominal Power Current - I _{MPP} (A)	8.20	8.30	8.40	8.52
Open Circuit Voltage - V _{OC} (V)	58.9	59.2	59.4	59.7
Short Circuit Current - I _{SC} (A)	8.80	8.84	8.88	8.91
Power Density (W/ft ²)	19.26	19.74	20.22	20.70
Panel Efficiency (%)	20.7	21.2	21.8	22.3

NMOT

Power Output - P _{MAX} (Wp)	305	312	320	327
Nominal Power Voltage - V _{MPP} (V)	46.0	46.6	47.1	47.6
Nominal Power Current - I _{MPP} (A)	6.64	6.70	6.80	6.88
Open Circuit Voltage - V _{OC} (V)	55.5	55.8	56.0	56.3
Short Circuit Current - I _{SC} (A)	7.11	7.16	7.20	7.24

Values at standard test conditions (STC: air mass AM1.5, irradiance 1075 W/sq ft (1000 W/m²), temperature 77°F (25°C), based on a production spread with a tolerance of P_{MAX}, V_{OC} & I_{SC} ±3% within one watt class. Nominal module operating temperature (NMOT: air mass AM1.5, irradiance 800 W/m², temperature 68°F (20°C), windspeed 3.3 ft/s (1 m/s). *Where xxx indicates the nominal power class (P_{MAX}) at STC above.

MAXIMUM RATINGS

Operational temperature:	-40 ... +85°C
System voltage:	1000 V
Test load (front):	+ 7000 Pa (146 lbs/ft ²)*
Test load (rear):	- 4000 Pa (83.5 lbs/ft ²)*
Series fuse rating:	25 A
Reverse current:	25 A

* See installation manual for mounting instructions. Design load = Test load / 1.5 (safety factor)

WARRANTY

	Standard	REC ProTrust
Installed by an REC Certified Solar Professional	No	Yes
System Size	All	<25 kW 25-500 kW
Product Warranty (yrs)	20	25
Power Warranty (yrs)	25	25
Labor Warranty (yrs)	0	25
Power in Year 1	98%	98%
Annual Degradation	0.25%	0.25%
Power in Year 25	92%	92%

See warranty documents for details. Conditions apply

Available from:

CERTIFICATIONS

IEC 61215:2016, IEC 61730:2016, UL 61730
IEC 62804 PID
IEC 61701 Salt Mist
IEC 62716 Ammonia Resistance
UL 61730 Fire Type Class 2
IEC 62782 Dynamic Mechanical Load
IEC 61215-2:2016 Hailstone (35mm)
IEC 62321 Lead-free acc. to RoHS EU 863/2015
ISO 14001, ISO 9001, IEC 45001, IEC 62941



TEMPERATURE RATINGS*

Nominal Module Operating Temperature:	44°C (±2°C)
Temperature coefficient of P _{MAX} :	-0.24 %/°C
Temperature coefficient of V _{OC} :	-0.24 %/°C
Temperature coefficient of I _{SC} :	0.04 %/°C

*The temperature coefficients stated are linear values

DELIVERY INFORMATION

Panels per pallet:	33
Panels per 40 ft GP/high cube container:	858 (26 pallets)
Panels per 53 ft truck:	858 (26 pallets)

LOW LIGHT BEHAVIOUR

Typical low irradiance performance of module at STC:

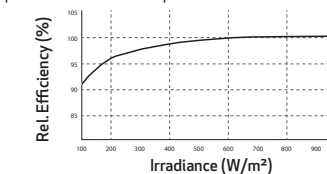

Founded in 1996, REC Group is an international pioneering solar energy company dedicated to empowering consumers with clean, affordable solar power. As Solar's Most Trusted, REC is committed to high quality, innovation, and a low carbon footprint in the solar materials and solar panels it manufactures. Headquartered in Norway with operational headquarters in Singapore, REC also has regional hubs in North America, Europe, and Asia-Pacific.



www.recgroup.com

Specifications subject to change without notice. Ref: PD-DS-AAPR Rev 3.1 03.23



IQ7X Microinverter

The high-powered, smart grid-ready IQ7X Microinverter dramatically simplifies the installation process while achieving the highest system efficiency for systems with 96-cell modules.



Part of the Enphase Energy System, the IQ7X Microinverter integrates with the IQ Gateway, IQ Battery, and the Enphase Installer App monitoring and analysis software.



The IQ Series Microinverters extend the reliability standards set forth by previous generations and undergo over a million hours of power-on testing, enabling Enphase to provide an industry-leading warranty of up to 25 years.*



Connect PV modules quickly and easily to IQ7X Microinverters using the included Q-DCC-2 adapter cable with plug-and-play MC4 connectors.



IQ7X Microinverters are UL Listed as PV rapid shutdown equipment and conform with various regulations when installed according to the manufacturer's instructions.

* 25-year warranty is valid, provided an internet-connected IQ Gateway is installed.

To learn more about Enphase offering, visit [Enphase.com](https://enphase.com)

Easy to install

- Lightweight and simple
- Faster installation with improved, lighter two-wire cabling
- Built-in rapid shutdown compliant (NEC 2014, 2017, 2020, and 2023)

Efficient and reliable

- Optimized for high powered 96-cell modules
- Highest CEC efficiency of 97.5%
- More than a million hours of testing
- Class II double-insulated enclosure
- UL Listed

Smart grid-ready

- Complies with advanced grid support, voltage, and frequency ride-through requirements
- Remotely updates to respond to changing grid requirements
- Configurable for varying grid profiles
- Meets CA Rule 21 (UL 1741-SA) and IEEE 1547:2018 (UL 1741-SB, 3rd Ed.)

IQ7X Microinverters

INPUT DATA (DC)	UNITS	IQ7X-96-2-US	
Commonly used module pairings ¹	W	320-460	
Module compatibility	—	To meet compatibility, PV modules must be within the following maximum input DC voltage and maximum module I _{sc} . Module compatibility can be checked at https://enphase.com/installers/microinverters/calculator .	
MPPT voltage range	V	53-64	
Operating range	V	25-79.5	
Minimum/Maximum start voltage	V	33/79.5	
Maximum input DC voltage	V	79.5	
Maximum continuous input DC current	A	6.5	
Maximum module I _{sc}	A	10	
Overtoltage class DC port	—	II	
DC port backfeed current	mA	0	
PV array configuration	—	1 x 1 ungrounded array; no additional DC side protection required; AC side protection requires a maximum of 20 A per branch circuit.	
OUTPUT DATA (AC)	UNITS	IQ7X-96-2-US@240 VAC	IQ7X-96-2-US@208 VAC
Peak output power	VA	320	
Maximum continuous output power	VA	315	
Nominal grid voltage (L-L)	V	240, split-phase (L-L), 180°	208, single-phase (L-L), 120°
Minimum and Maximum grid voltage ²	V	211-264	183-229
Maximum continuous output current	A	1.31	1.51
Nominal frequency	Hz	60	
Extended frequency range	Hz	49-68	
AC short-circuit fault current over three cycles	A _{max}	5.8	
Maximum units per 20 A (L-L) branch circuit ³	—	12	10
Overtoltage class AC port	—	III	
AC port backfeed current	mA	18	
Power factor setting	—	1.0	
Grid-tied power factor (adjustable)	—	0.85 leading ... 0.85 lagging	
CEC weighted efficiency	%	97.5	97.0
MECHANICAL DATA	UNITS		
Ambient temperature range	°C (°F)	-40 to 60 (-40 to 140)	
Relative humidity range	%	4 to 100 (condensing)	
DC connector type	—	MC4 (or Amphenol H4 UTX with additional Q-DCC-5 adapter)	
Dimensions (H x W x D)	mm (in)	212 (8.3) x 175 (6.9) x 30.2 (1.2)	
Weight	kg (lbs)	1.1 (2.4)	
Cooling	—	Natural convection-no fans	
Approved for wet locations	—	Yes	
Pollution degree	—	PD3	
Enclosure	—	Class II double-insulated, corrosion-resistant polymeric enclosure	
Environmental category/UV exposure rating	—	NEMA Type 6/Outdoor	
COMPLIANCE			
Compliance	CA Rule 21 (UL 1741-SA), IEEE 1547:2018 (UL 1741-SB 3 rd Ed.), HEI Rule 14H SRD 2.0 UL 62109-1, FCC Part 15 Class B, ICES-0003 Class B, CAN/CSA-C22.2 NO. 107.1-01 This product is UL Listed as PV rapid shutdown equipment and conforms with NEC 2014, NEC 2017, NEC 2020, and NEC 2023 section 690.12 and C22.1-2015, Rule 64-218 rapid shutdown of PV Systems for AC and DC conductors when installed according to the manufacturer's instructions.		

(1) Pairing PV modules with wattage above the limit may result in additional clipping losses.
 (2) Nominal voltage range can be extended beyond nominal if required by the utility.
 (3) Limits may vary. Refer to local requirements to define the number of microinverters per branch in your area.

IQ Combiner 4/4C



The **IQ Combiner 4/4C** with IQ Gateway and integrated LTE-M1 cell modem (included only with IQ Combiner 4C) consolidates interconnection equipment into a single enclosure. It streamlines IQ Microinverters and storage installations by providing a consistent, pre-wired solution for residential applications. It offers up to four 2-pole input circuits and Eaton BR series busbar assembly.

Smart

- Includes IQ Gateway for communication and control
- Includes Mobile Connect cellular modem (CELLMODEM-M1-06-SP-05), included only with IQ Combiner 4C
- Includes solar shield to match Enphase IQ Battery aesthetics and deflect heat
- Supports Wi-Fi, Ethernet, or cellular connectivity
- Optional AC receptacle available for PLC bridge
- Provides production metering and consumption monitoring

Simple

- Mounts on single stud with centered brackets
- Supports bottom, back and side conduit entry
- Allows up to four 2-pole branch circuits for 240VAC plug-in breakers (not included)
- 80A total PV or storage branch circuits

Reliable

- Durable NRTL-certified NEMA type 3R enclosure
- Five-year limited warranty
- Two years labor reimbursement program coverage included for both the IQ Combiner SKU's
- UL listed
- X2-IQ-AM1-240-4 and X2-IQ-AM1-240-4C comply with IEEE 1547:2018 (UL 1741-SB, 3rd Ed.)

IQ Combiner 4/4C

MODEL NUMBER

IQ Combiner 4 X-IQ-AM1-240-4 X2-IQ-AM1-240-4 (IEEE 1547:2018)	IQ Combiner 4 with IQ Gateway printed circuit board for integrated revenue grade PV production metering (ANSI C12.20 ± 0.5%) and consumption monitoring (± 2.5%). Includes a silver solar shield to match the IQ Battery and IQ System Controller 2 and to deflect heat.
IQ Combiner 4C X-IQ-AM1-240-4C X2-IQ-AM1-240-4C (IEEE 1547:2018)	IQ Combiner 4C with IQ Gateway printed circuit board for integrated revenue grade PV production metering (ANSI C12.20 ± 0.5%) and consumption monitoring (± 2.5%). Includes Mobile Connect cellular modem (CELLMODEM-M1-06-SP-05), a plug-and-play industrial-grade cell modem for systems up to 60 microinverters. (Available in the US, Canada, Mexico, Puerto Rico, and the US Virgin Islands, where there is adequate cellular service in the installation area.) Includes a silver solar shield to match the IQ Battery and IQ System Controller and to deflect heat.

ACCESSORIES AND REPLACEMENT PARTS (not included, order separately)

Supported microinverters	IQ6, IQ7, and IQ8. (Do not mix IQ6/7 Microinverters with IQ8)
Communications Kit COMMS-CELLMODEM-M1-06 CELLMODEM-M1-05-SP-05 CELLMODEM-M1-05-AT-05	- Includes COMMS-KIT-01 and CELLMODEM-M1-06-SP-05 with 5-year Sprint data plan - 4G based LTE-M1 cellular modem with 5-year Sprint data plan - 4G based LTE-M1 cellular modem with 5-year AT&T data plan
Circuit Breakers BRK-10A-2-240V BRK-15A-2-240V BRK-20A-2P-240V BRK-15A-2P-240V-B BRK-20A-2P-240V-B	Supports Eaton DR210, DR215, DR220, DR220, DR240, DR250, and DR260 circuit breakers. Circuit breaker, 2 pole, 10A, Eaton BR210 Circuit breaker, 2 pole, 15A, Eaton BR215 Circuit breaker, 2 pole, 20A, Eaton BR220 Circuit breaker, 2 pole, 15A, Eaton BR215B with hold down kit support Circuit breaker, 2 pole, 20A, Eaton BR220B with hold down kit support
XA-SOLARSHIELD-ES	Replacement solar shield for IQ Combiner 4/4C
XA-PLUG-120-3	Accessory receptacle for Power Line Carrier in IQ Combiner 4/4C (required for EPLC 01)
X-IQ-NA-HD-125A	Hold-down kit for Eaton circuit breaker with screws
Consumption monitoring CT (CT-200-SPLIT/CT-200-CLAMP)	A pair of 200A split core current transformers

ELECTRICAL SPECIFICATIONS

Rating	Continuous duty
System voltage	120/240VAC, 60 Hz
Eaton BR series busbar rating	125A
Max. continuous current rating	65A
Max. continuous current rating (input from PV/storage)	64A
Max. fuse/circuit rating (output)	90A
Branch circuits (solar and/or storage)	Up to four 2-pole Eaton BR series Distributed Generation (DG) breakers only (not included)
Max. total branch circuit breaker rating (input)	80A of distributed generation/95A with IQ Gateway breaker included
IQ Gateway breaker	10A or 15A rating GE/Siemens/Eaton included
Production metering CT	200A solid core pre-installed and wired to IQ Gateway

MECHANICAL DATA

Dimensions (WxHxD)	37.5 cm x 49.5 cm x 16.8 cm (14.75 in x 19.5 in x 6.63 in). Height is 53.5 cm (21.06 in) with mounting brackets.
Weight	7.5 kg (16.5 lbs)
Ambient temperature range	-40°C to +46°C (-40°F to 115°F)
Cooling	Natural convection, plus heat shield
Enclosure environmental rating	Outdoor, NRTL-certified, NEMA type 3R, polycarbonate construction
Wire sizes	<ul style="list-style-type: none"> • 20A to 50A breaker inputs: 14 to 4 AWG copper conductors • 60A breaker branch input: 4 to 1/0 AWG copper conductors • Main lug combined output: 10 to 2/0 AWG copper conductors • Neutral and ground: 14 to 1/0 copper conductors • Always follow local code requirements for conductor sizing.
Altitude	Up to 3,000 meters (9,842 feet)

INTERNET CONNECTION OPTIONS

Integrated Wi-Fi	IEEE 802.11b/g/n
Cellular	CELLMODEM-M1-06-SP-05, CELLMODEM-M1-06-AT-05 (4G based LTE-M1 cellular modem). Note that an Mobile Connect cellular modem is required for all Enphase Energy System installations.
Ethernet	Optional, IEEE 802.3, Cat5E (or Cat6) UTP Ethernet cable (not included)

COMPLIANCE

Compliance, IQ Combiner	CA Rule 21 (UL 1741-SA) IEEE 1547:2018 - UL 1741-SB, 3 rd Ed. (X2-IQ-AM1-240-4 and X2-IQ-AM1-240-4C) CAN/CSA C22.2 No. 107.1, Title 47 CFR, Part 15, Class B, ICES 003 Production metering: ANSI C12.20 accuracy class 0.5 (PV production) Consumption metering: accuracy class 2.5
Compliance, IQ Gateway	UL 60601-1/CANCSA 22.2 No. 61010-1



To learn more about Enphase offerings, visit enphase.com
IQ-C-4-4C-DS-0103-EN-US-12-29-2022



Enphase Q Cable and Accessories

The **Enphase Q Cable™** and accessories are part of the sixth generation Enphase IQ System™. These products provide simplicity, reliability, and faster installation times.



Enphase Q Cable

- Two-wire, double-insulated Enphase Q Cable is 50% lighter than the previous generation Enphase cable
- Four-wire (three-phase) option also available
- New cable numbering and plug and play connectors speed up installation and simplify wire management
- Link connectors eliminate cable waste



Field-Wireable Connectors

- Easily connect Q cables on the roof without complex wiring
- Make connections from any open connector and center feed any section of cable within branch limits
- Available in male and female connector types

Enphase Q Cable Accessories

Q CABLE SPECIFICATIONS



Voltage rating	600V (connector rating up to 250 V)
Cable temperature rating	90° C wet/dry
UV exposure rating	EN ISO 492-2
Environmental protection rating	IEC 60529 IP67
Compliance	RoHS, OIL RES I, CE, UV resistant
Cable insulator rating	H07BQ-F
Flame rating	IEC 60332-1-2

Q CABLE TYPES / ORDERING OPTIONS

Model Number	Max Nominal Voltage	Ampacity Rating	Connector Spacing	PV Module Orientation	Connector Count per Box
Q-25-10-240 (single-phase)	250 VAC	25 A	1.3 m	Portrait	240
Q-25-17-240 (single-phase)	250 VAC	25 A	2.0 m	Landscape (60-cell)	240
Q-25-20-200 (single-phase)	250 VAC	25 A	2.3 m	Landscape (72-cell)	200
Q-25-10-3P-200 (three-phase)	250 VAC	25 A	1.3 m	Portrait	200
Q-25-17-3P-160 (three-phase)	250 VAC	25 A	2.0 m	Landscape (60-cell)	160
Q-25-20-3P-160 (three-phase)	250 VAC	25 A	2.3 m	Landscape (72-cell)	160

ENPHASE Q CABLE ACCESSORIES

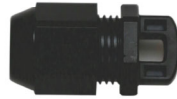
Name	Model Number	Description
Raw Q Cable (single-phase)	Q-25-RAW-300	300 meters cable with no connectors
Raw Q Cable (three-phase)	Q-25-RAW-3P-300	300 meters cable with no connectors
Field-wireable connector (male)	Q-CONN-R-10M	Make connections using single-phase cable
Field-wireable connector (male)	Q-CONN-3P-10M	Make connections using three-phase cable
Field-wireable connector (female)	Q-CONN-R-10F	Make connections from any Q Cable (single-phase) open connector
Field-wireable connector (female)	Q-CONN-3P-10F	Make connections from any Q Cable (three-phase) open connector
Cable Clip	ET-CLIP-100	Used to fasten cabling to the racking or to secure looped cabling
Disconnect tool	Q-DISC-10	Disconnect tool for Q Cable connectors, DC connectors, and AC module mount
Disconnect tool	Q-DISC-3P-10	Disconnect tool for three-phase Field wireable connectors
Q Cable sealing caps (female)	Q-SEAL-10	One needed to cover each unused connector on the cabling
Terminator (single-phase)	Q-TERM-R-10	Terminator cap for unused single-phase cable ends
Terminator (three-phase)	Q-TERM-3P-10	Terminator cap for unused three-phase cable ends
Replacement DC Adaptor (MC4)	Q-DCC-2-INT	DC adaptor to MC4 (max voltage 100 VDC)

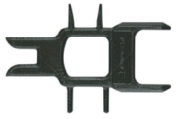
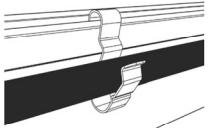
	TERMINATOR Terminator cap for unused cable ends, sold in packs of ten (Q-TERM-R-10 / Q-TERM-3P-10))		SEALING CAPS Sealing caps for unused cable connections, sold in packs of ten (Q-SEAL-10)
	DISCONNECT TOOL Plan to use at least one per installation, sold in packs of ten (Q-DISC-10) Three-phase model (Q-DISC-3P-10)		CABLE CLIP Used to fasten cabling to the racking or to secure looped cabling, sold in packs of one hundred (ET-CLIP-100)

IQ Gateway



IQ Gateway

The IQ Gateway delivers solar production and energy consumption data to Enphase Installer Portal monitoring and analysis software for comprehensive, remote maintenance, and management of Enphase systems.

With integrated production metering and optional consumption monitoring, the IQ Gateway is the platform for total energy management. It integrates with the IQ System Controller and IQ Battery.



IQ Series Microinverters
The high-powered smart grid-ready IQ Series Microinverters (IQ6, IQ7, and IQ8 Series) dramatically simplify the installation process.



IQ System Controller
Provides microgrid interconnect device (MID) functionality by automatically detecting grid failures and seamlessly transitioning the home energy system from grid power to backup power.



IQ Battery
All-in-one AC coupled storage system that is reliable, smart, simple, and safe. It provides backup capability and installers can quickly design the right system size to meet the needs of both new and retrofit solar customers.



IQ Load Controller
Helps prioritize essential appliances during a grid outage to optimize energy consumption and prolong battery life.

Smart

- Enables web-based monitoring and control
- Provides bidirectional communications for remote upgrades
- Supports power export limiting and zero-export applications

Simple

- Easy system configuration using Enphase Installer App
- Flexible networking with Wi-Fi, Ethernet, or cellular

Reliable

- Designed for installation indoors or outdoors in a NEMA 3R rated enclosure
- 5-year limited warranty
- ENV2-IQ-AM1-240 complies with IEEE 1547:2018 (UL 1741-SB, 3rd Ed.)

MODEL NUMBER		ENV-IQ-AM1-240, ENV2-IQ-AM1-240
IQ Gateway ENV-IQ-AM1-240 ENV2-IQ-AM1-240 (IEEE 1547:2018)	IQ Gateway integrates revenue grade PV production metering (ANSI C12.20 ±0.5%), consumption metering (±2.5%), and battery metering (±2.5%) with IQ Battery 5P. Includes one 200 A continuous rated Production current transformer (CT).	
ACCESSORIES - ORDER SEPARATELY		
Mobile Connect COMMS-CELLMODEM-M1-06 CELLMODEM-M1-06-SP-05 CELLMODEM-M1-06-AT-05	- Includes COMMS-KIT-01 and CELLMODEM-M1-06-SP-05 with 5-year Sprint data plan - 4G based LTE-M1 cellular modem with 5-year Sprint data plan - 4G based LTE-M1 cellular modem with 5-year AT&T data plan	
Consumption monitoring CT and IQ Battery 5P metering CT CT-200-SPLIT CT-200-CLAMP	Split-core and clamp style CTs with 2.5% accuracy enable whole home and IQ Battery 5P metering	
Communications Kit COMMS-KIT-01 COMMS-KIT-02	Installed at the IQ Gateway. For communications with IQ Battery and IQ System Controller. Includes USB cable for connection to IQ Gateway or IQ Combiner and allows wireless communication with IQ Battery and IQ System Controller.	
POWER REQUIREMENTS		
Power requirements	120/240 VAC split-phase maximum 20 A overcurrent protection required	
Typical power consumption	5 W	
CAPACITY		
Number of microinverters polled	Up to 300	
MECHANICAL & ELECTRICAL DATA		
Dimensions (W×H×D)	21.3 cm × 12.6 cm × 4.5 cm (8.4 in × 5 in × 1.8 in)	
Weight	1.09 lb	
Ambient temperature range	-40°C to 65°C (-40°F to 149°F) [ENV-IQ-AM1-240] -40°C to 50°C (-40°F to 122°F) [ENV2-IQ-AM1-240] -40°C to 46°C (-40°F to 115°F) if installed in an enclosure	
Environmental rating	IP30. For installation indoors or in an NRTL-certified, NEMA type 3R or better-rated enclosure, if installing outdoors.	
Altitude	Up to 2,600 meters (8,530 feet)	
COMMUNICATION INTERFACES		
Integrated Wi-Fi	802.11b/g/n (2.4 GHz, 5 GHz), for connecting the Enphase Cloud via the internet.	
Wi-Fi range (recommended)	10 m	
Ethernet	Optional, 802.3, Cat5E (or Cat 6) UTP Ethernet cable (not included), for connecting to the Enphase Cloud via the internet.	
Mobile Connect	CELLMODEM-M1-06-SP-05, CELLMODEM-M1-06-AT-05 (to be purchased separately, mandatory for sites with IQ Battery)	
Digital I/O	Digital input/output for grid operator control	
USB 2.0	For Mobile Connect and Communications Kit	
Access point (AP) mode	For a connection between the IQ Gateway and a mobile device running the Enphase Installer App	
Metering ports	Up to two Consumption CTs, one Production CT, and one battery CT (for IQ Battery 5P)	
Power line communication (PLC)	90-110 kHz (Class B), to microinverters.	
Web API	Refer to https://developer-v4.enphase.com	
Local API	Refer to guide for local API	
LED indicators	From top to bottom: Cloud connectivity, Wi-Fi access point mode, PV production state, PLC communications state	
Configured via	Enphase Installer App and Enphase Installer Platform	



POWER PRODUCTION/EXPORT LIMITING VIA THE IQ GATEWAY'S DIGITAL IQ	
Maximum relays read	4
Capabilities supported	Power production limiting (Production CT/s required), power export limiting (Production CT/s required and Consumption CT/s – "Load with Solar" configuration)
Minimum IQ Gateway version	v7.3.120
Cable configurations	18 AWG, UL-Std. 62, 600 V, 105°C, and min 0.03 inches average thickness
Signal voltage range	2.5 V–5 V (digital high), 0 V–1.9 V (digital low)
Terminal blocks	Five terminals, up to 0.002 in ²
Configuration via	Enphase Installer App, Enphase Installer Platform (site settings)

SCOPE OF DELIVERY	
Package dimensions (H x W x D)	6.3" x 10.8" x 3.9"
Package weight	2.2 lb
Aluminium DIN rail	4.9 in
Current transformers (CTs)	One CT-200-SOLID included

COMPLIANCE	
Compliance	CA Rule 21 (UL 1741-SA), IEEE 1547:2018 - UL 1741-SB, 3rd Ed.(ENV2-IQ-AM1-240), UL 61010-1 CAN/CSA C22.2 No. 61010-1 Title 47 CFR, Part 15, Class B, ICES 003 IEC/EN 61010-1:2010, EN50065-1, EN61000-4-5, EN61000-6-1, EN61000-6-2 Metering: ANSI C12.20 accuracy class 0.5 (PV production only)

COMPATABILITY	
IQ System Controller	SC200D111C240US01, SC200G111C240US01, EP200G101-M240US01, EP200G101-M240US00
IQ Battery	IQBATTERY-5P-1P-NA, ENCHARGE-3T-1P-NA, ENCHARGE-10T-1P-NA
Microinverter	IQ6, IQ7, and IQ8 Series Microinverters

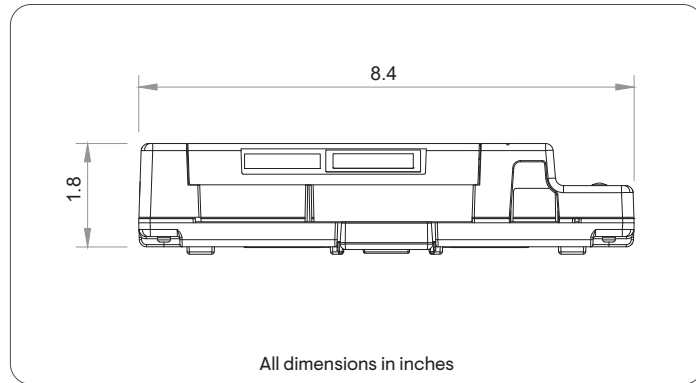
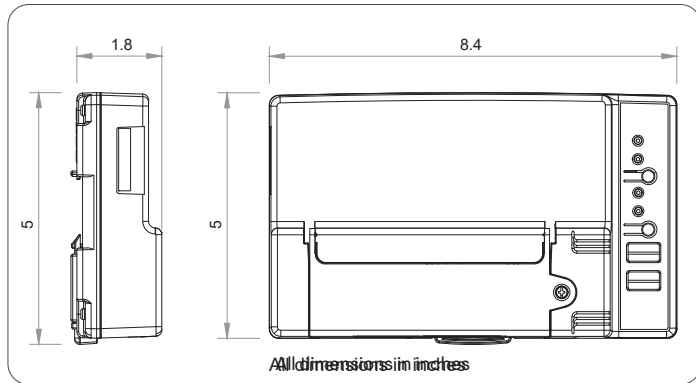

Accessories



Enphase Mobile Connect

4G-based LTE-M1 cellular modem with a 5-year data plan
(CELLMODEM-M1-06-SP-05 for Sprint and CELLMODEM-M1-06-AT-05 for AT&T)



Circuit breakers

BRK-10A-2-240V Circuit breaker, 2-pole, 10 A, Eaton BR210
BRK-15A-2-240V Circuit breaker, 2-pole, 15 A, Eaton BR215
BRK-20A-2P-240V Circuit breaker, 2-pole, 20 A, Eaton BR220
BRK-15A-2P-240V-B Circuit breaker, 2-pole, 15 A, Eaton BR215B with hold-down kit support
BRK-20A-2P-240V-B Circuit breaker, 2-pole, 20 A, Eaton BR220B with hold-down kit support



CT-200-SOLID

200 A revenue grade solid core Production CT with <0.5% error rate (replacement SKU)



CT-200-CLAMP

200 A clamp-style consumption and battery metering CT with <2.5% error rate (replacement SKU)

Revision history

REVISION	DATE	DESCRIPTION
DSH-00111-2.0	August 2023	Updated temperature specification for ENV2-IQ-AM1-240
DSH-00111-1.0	June 2023	Updated altitude and recommended maximum microinverters on a site.



INSTAFLASH™

Never Deal With Caulking Again!

Factory-installed, non-hardening sealant



Before InstaFlash Installed:
Sealant is contained above roof surface by a protective cage.



After InstaFlash Installed:
Sealant is compressed to fill all holes and voids.

Protective Cage

Prevents sealant from getting on hands or roof. Collapses upon lag installation.

Effortless Lifetime Roof Protection

The non-hardening sealant completely fills any missed pilot holes, shingle rips, voids, or other potential water ingress points under the entire footprint of the 4.6" wide base.



25-Year Warranty

Manufactured with advanced materials and coatings to outlast the roof itself



Code Compliant

Fully IBC/CBC Code Compliant Exceeds ASCE 7-16 Standards FL Cert of Approval FL41396 UL2703 Certified



Self-Healing

The proprietary non-hardening sealant will flex and reseal over years of thermal expansion and contraction



Larger Spans

The extra-large L-foot and proprietary lag screw result in larger spans between mounts



INSTAFLASH™

1
Drill pilot hole in the center of the rafter using a 7/32" bit.



2
Place the InstaFlash over the pilot hole. **Note:** the direction of the InstaFlash Down arrows should point down the roof.



3
Insert the lag screw through the center hole into the pilot hole.



4
Drive the lag until the InstaFlash is fully seated to the roof.

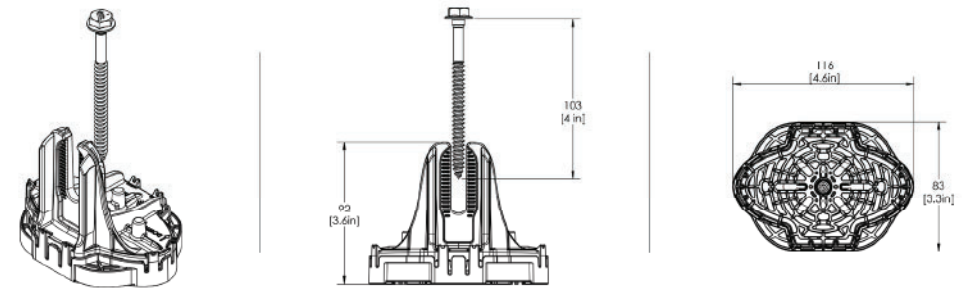

SPECIFICATIONS	INSTAFLASH KITS				
	PIF-RB0	PIF-RBDT	PIF-RBSH	PIF-RM0	PIF-RMDT
Finish	Black			Mill	
Kit Contents	Black InstaFlash, 5/16" x 4.0" SS Lag	Black InstaFlash, 5/16" x 4.0" SS Lag, Dovetail T-bolt w/ Nut	Black InstaFlash, 5/16" x 4.0" SS Lag, M10 Hex Bolt w/ Nut	Mill Insta-Flash, 5/16" x 4.0" SS Lag	Mill InstaFlash, 5/16" x 4.0" SS Lag, Dovetail T-bolt w/ Nut
Attachment Type	Rafter Attached				
Roof Type	Sloped Roof: Composition Shingle, Rolled Asphalt Flat roof: Modified Bitumen Roof, Built-Up Roof				
Sealant Application	Factory Installed				
Installation Temperature	0°F to 170° F				
Cure Time	Instantly Waterproof; Non-hardening				
Service Temperature	-40°F to 195° F				
Certifications	IBC, ASCE/SEI 7-16, FL Cert of Approval FL41396, TAS 100(A), UL2703				
Install Application	Most Railed Systems, Pegasus Tilt Leg Kit				
Kit Quantity	24				
Boxes per Pallet	36				

US Patents Pending. All rights reserved. ©2023 Pegasus Solar Inc.



SCAN FOR INSTALLATION VIDEO



SCAN FOR FREE TRIAL



RAIL SYSTEM

Instant Bonding

The N-S Bonding Jumper bonds row to row with no tools.



One Clamp Anywhere

The Multi-Clamp works as mid- or end-clamp, and fits standard 30-40mm frames.



Lifetime Wire Management

Open rail channel holds and protects wires. Clamps won't pinch wires after tightening.



Bonding Structural Splice

Connect rails instantly, without tools, interference or limitations.

Next-Level Solar Mounting

A complete system for hassle-free rooftop installation, from watertight mounts to lifetime wire management.



Simplicity

1/2" socket for everything. One clamp for mid or end. No tool splicing and bonding. Easy wire management.



Code Compliant

UL 2703 listed
LTR-AE-001-2012 listed
Class A fire rating for any slope
ASCE 7-16 PE Certified
FL Cert of Approval FL41396



Premium Aesthetics

The narrowest panel gap available. Optional Hidden End Clamps and End Caps provide a flush look on the edge of the array.



Watertight for Life

Secured on industry-leading Pegasus Mounts, for composite shingle and tile roofs. Backed by a 25-year warranty.



RAIL SYSTEM



Pegasus Rail	Pegasus Max Rail	Splice and Max Splice	Dovetail T-bolt
--------------	------------------	-----------------------	-----------------

Available in 14' and 7' lengths for easy layout and shipping.
Open-channel design holds MC4 connectors, PV wire and trunk cables.
Black and Mill finish

Maximum-strength design.
Meets specifications for high snow-load and hurricane zones.
Black and Mill finish

Installs by hand.
Works over mounts.
Structurally connects and bonds rails automatically; UL2703 listed as reusable.

Dovetail shape for extra strength.
Uses 1/2" socket.



Multi-Clamp	Hidden End Clamp	Ground Lug	N-S Bonding Jumper
-------------	------------------	------------	--------------------

Fits 30-40mm PV frames, as mid- or end-clamp.
Twist-locks into position; doesn't pinch wires in rail.
Bonds modules to rail; UL2703 listed as reusable

Offers premium edge appearance.
Preinstalled pull-tab grips rail edge, allowing easy, one-hand installation.
Tucks away for reuse.

Holds 6 or 8 AWG wire.
Mounts on top or side of rail.
Assembled on MLPE Mount.
UL2703 listed as reusable.

Installs by hand, eliminates row-to-row copper wire.
UL2703 listed as reusable only with Pegasus Rail.

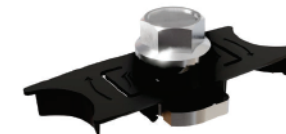

MLPE Mount	Cable Grip	Wire Clip	End Cap and Max End Cap
------------	------------	-----------	-------------------------

Secures and bonds most micro-inverters and optimizers to rail.
Connectors and wires easily route underneath after installation.
UL2703 listed as reusable.

Secures four PV wires or two trunk cables.
Stainless-steel backing provides durable grip.
Eliminates sagging wires.

Hand operable.
Holds wires in channel.
Won't slip.

Fits flush to PV module and hides raw or angled cuts.
Hidden drain quickly clears water from rail.

Certifications:

- UL 2703, Edition 1
- LTR-AE-001-2012
- ASCE 7-16 PE certified
- Class A fire rating for any slope roof
- FL Cert of Approval FL41396



Quickly calculate the most efficient layout, spans and materials needed to suit your job. Visit the Pegasus Customer Portal. pegasussolar.com/portal

Patents pending. All rights reserved. ©2023 Pegasus Solar Inc.

LOAD		SPAN				
SNOW (psf)	WIND (MPH)	32"	48"	72"	96"	120"
0	100	Pegasus Rail	Pegasus Rail	Pegasus Rail	Pegasus Rail	Pegasus Rail
	130					
10	140	Pegasus Rail	Pegasus Rail	Pegasus Rail	Pegasus Rail	Pegasus Rail
	190					
30	190	Pegasus Rail	Pegasus Rail	Pegasus Rail	Pegasus Rail	Pegasus Rail
100	190	Pegasus Rail	Pegasus Rail	Pegasus Rail	Pegasus Rail	Pegasus Rail
120	190	Pegasus Rail	Pegasus Rail	Pegasus Rail	Pegasus Rail	Pegasus Rail

For reference only. Spans above are calculated using 7-16 for a Gable Roof, Exposure Category B, 0-20deg roof angle, 30ft mean roof height with non-exposed modules. For PE certified span tables, visit www.pegasussolar.com/spans.



SK'PRAIL

Skip Rows!

Eliminate entire rows of mounts, rails and clamps by adding just one SKU!

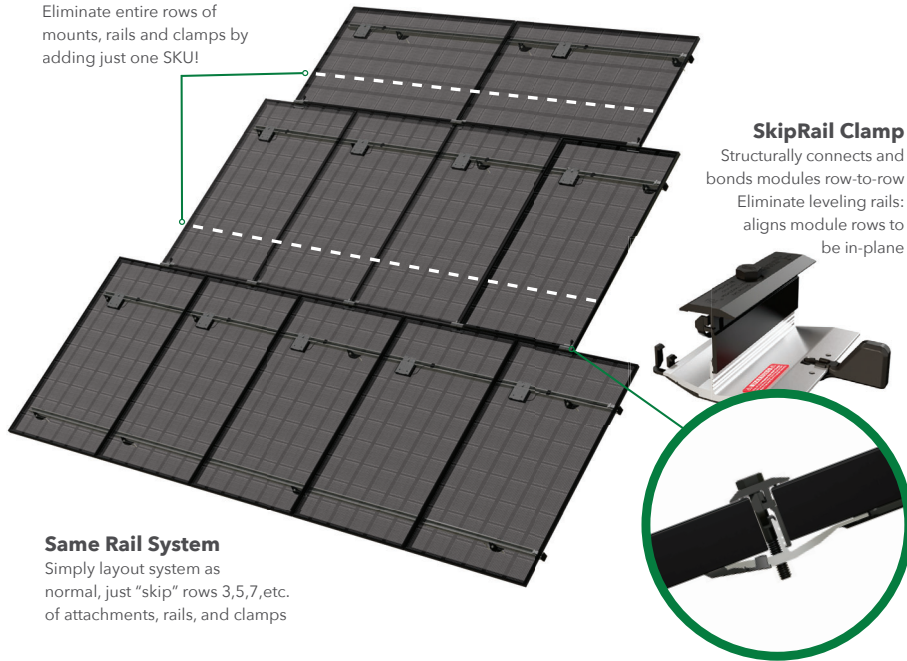

SkipRail Clamp
Structurally connects and bonds modules row-to-row
Eliminate leveling rails: aligns module rows to be in-plane

Same Rail System

Simply layout system as normal, just "skip" rows 3,5,7, etc. of attachments, rails, and clamps

A Revolution in Solar Installations

Lower your costs and provide your crews a faster system by eliminating entire rows of mounts, rails and clamps with just one SKU.



Dramatically Lower Costs

25% fewer rails and clamps
15% fewer roof penetrations
3500 lbs less per MW to ship, warehouse, pack, and load



Recruit the Best Crews

Less work = happier crews
300 lbs less per week to haul
Faster install
Auto-levels modules



Easy to Implement

Minimal to no training
Same layout as standard rail
Same open-channel wire management



Universal to Any Roof

Comp, Tile, Metal, other.
Low slope, steep slopes
Easily work around roof obstructions
Mixed portrait / landscape

Pegasus Solar Inc | 506 West Ohio Avenue, Richmond, CA 94804 | www.pegasussolar.com



SK'PRAIL

SkipRail SAVINGS | 18% fewer attachments • 32% fewer feet of rails
22% fewer pounds to ship & warehouse

SkipRail SAVINGS | 21% fewer attachments • 30% fewer feet of rails
21% fewer pounds to ship & warehouse



Example of Comp Roof Array

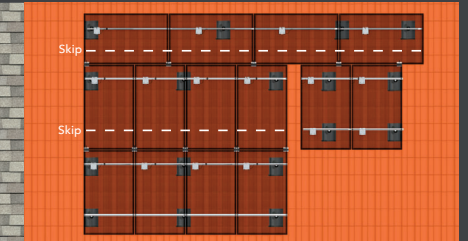

Example of Tile Roof Array

Free Design Tool:

pegasussolar.com/portal

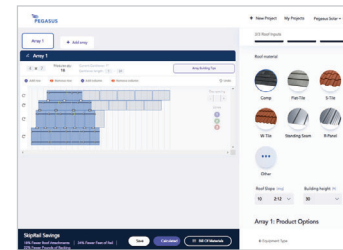

Where SkipRail Works

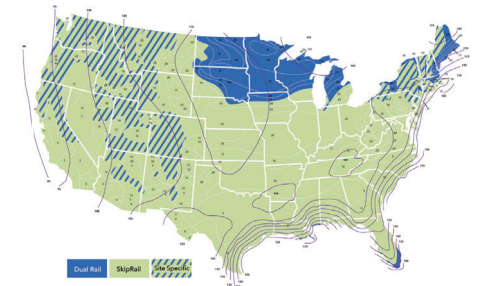

Specifications

SkipRail Kits

	PSR-SRC	PSR-SRCK
SKU	PSR-SRC	PSR-SRCK
Type	Floating Clamp	Extra support with Kickstand
Finish	Black	
PV module frames	30, 32, 35, 40mm	
Certifications	ASCE 7-16, IBC, CBC, UL2703	
Applicable Roof Types	Any	
Compatible Rail Systems	Pegasus Rail System	
Kit Contents	Pegasus SkipRail Clamp	Pegasus SkipRail Clamp with Kickstand
Kit Quantity	20	30

Patents pending. All rights reserved. ©2023 Pegasus Solar Inc.



SCAN FOR VIDEO



SCAN FOR FREE TRIAL

Pegasus Solar Inc | 506 West Ohio Avenue, Richmond, CA 94804 | www.pegasussolar.com

Pegasus Rail System - Bond Path to Ground

Ground Lug & N-S Bonding Jumper

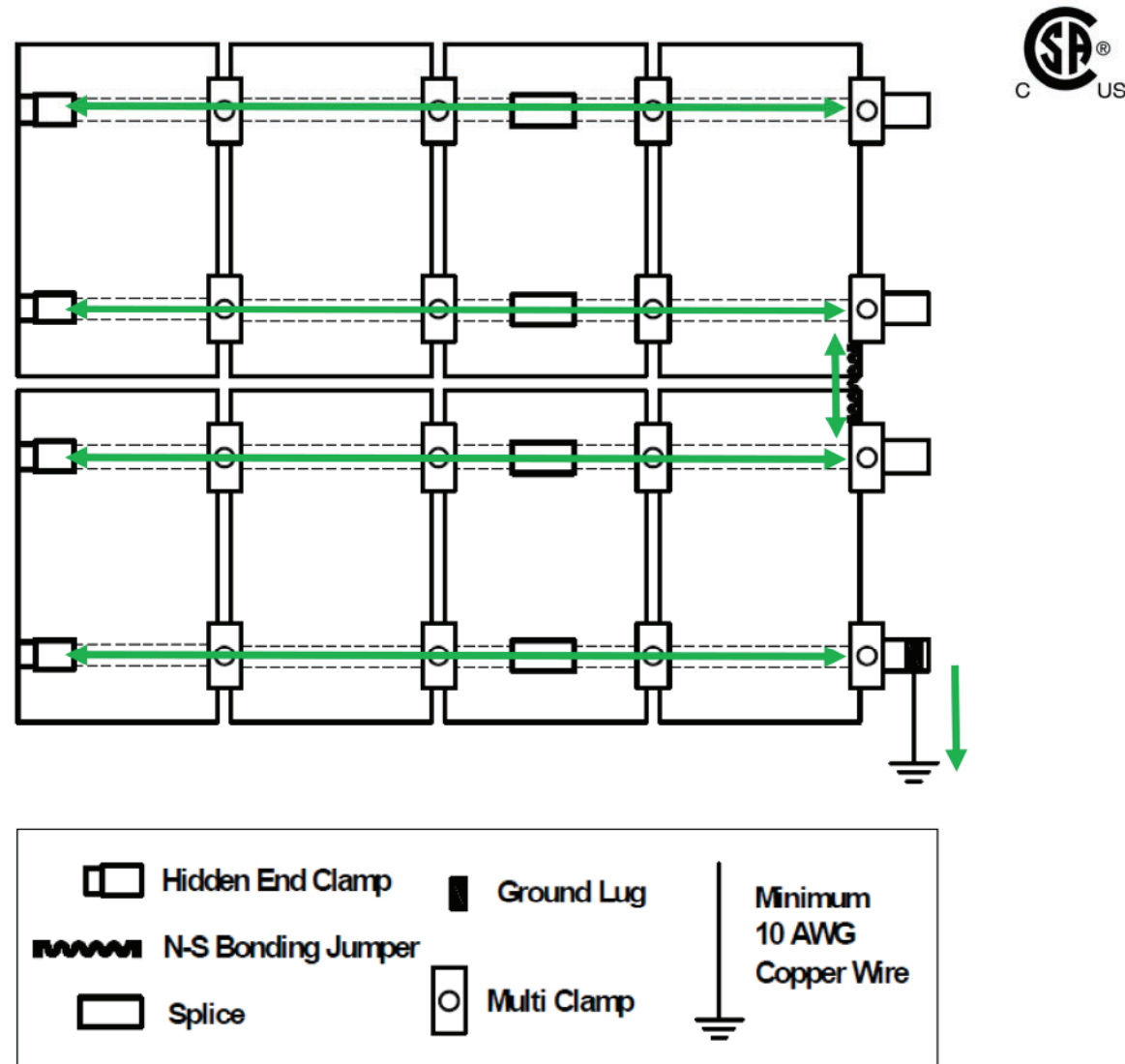

Multi-Clamps bond adjacent PV modules to one another and to the Rail. The Splice provides a bond connection between two Rail sections, including when a 1" thermal gap is utilized. The N-S Bonding Jumper will provide a bonding path between rows of PV modules, so that one Ground Lug per array is necessary for earth ground. If a thermal break is left between two sections or Rail, the Multi-Clamps will provide a bond path across the two Rails through the PV module frame.

The N-S Bonding Jumper may only be used with the Pegasus Rail System, and is not certified for use with any other mounting system.

If the N-S Bonding Jumper needs to be removed during maintenance, a second N-S Bonding Jumper shall first be



Pegasus Rail System - Bond Path to Ground

Ground Lug for each PV Module Row

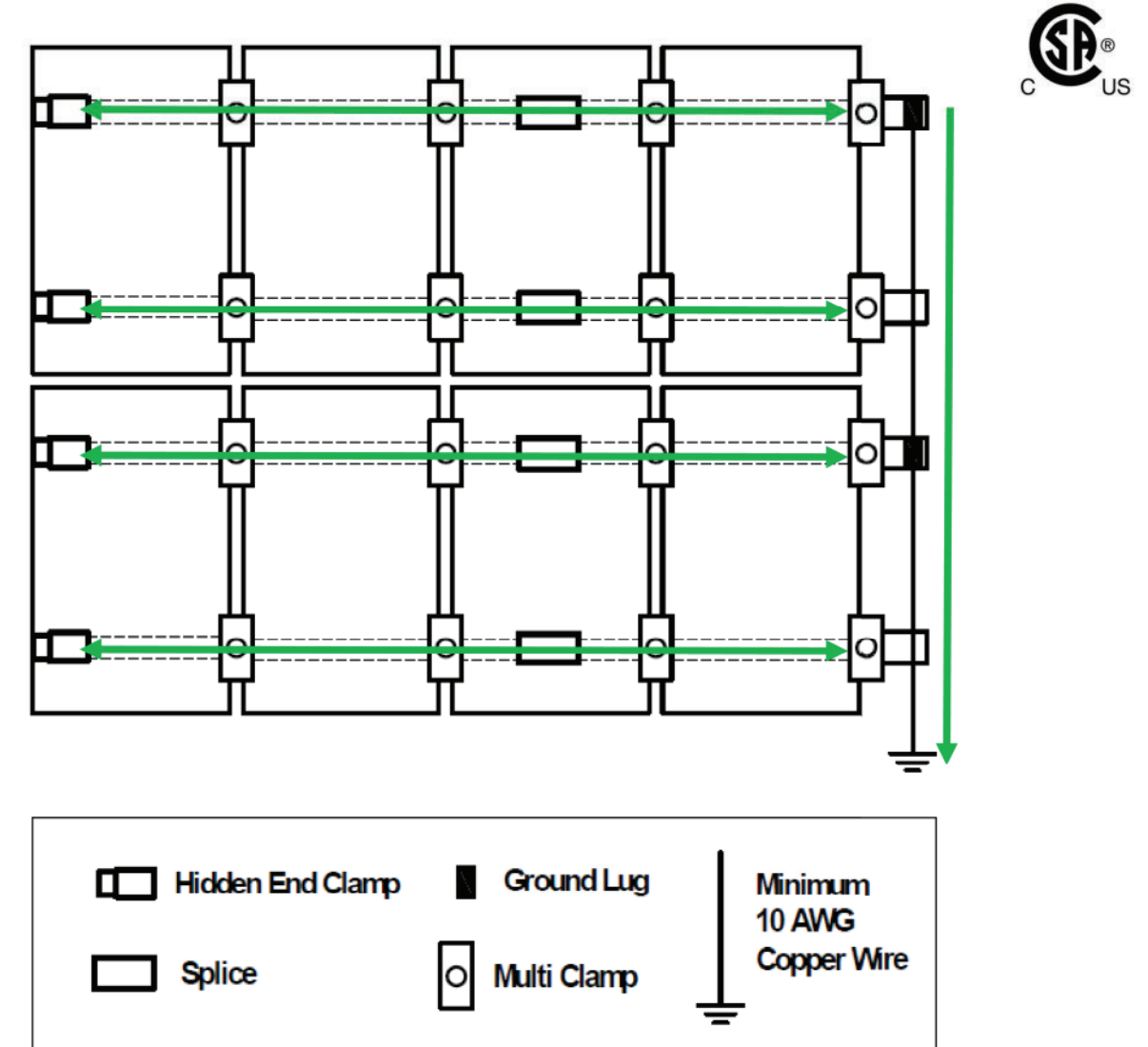

Multi-Clamps bond adjacent PV modules to one another and to the Rail. The Splice provides a bond connection between two Rail sections, including when a 1" thermal gap is utilized. One Ground Lug is required per row of PV Modules, with a final earth ground connection at the terminal end of the ground wire. If a thermal break is left between two sections or Rail, the Multi-Clamps will provide a bond path across the two Rails through the PV module frame.



Pegasus Rail System - Bond Path to Ground

SkipRail System

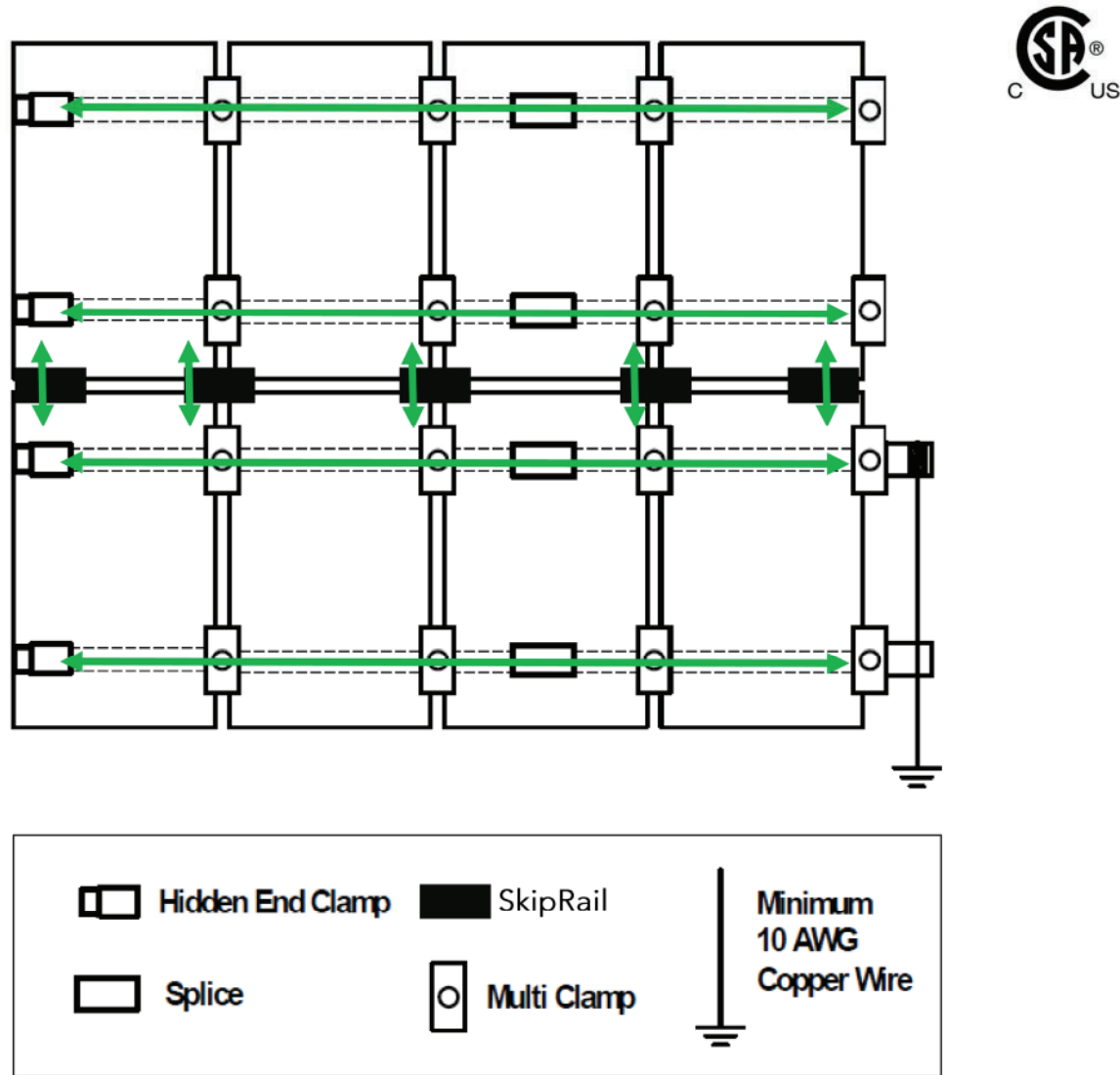

Multi-Clamps bond adjacent PV modules to one another and to the Rail. The Splice provides a bond connection between two Rail sections, including when a 1" thermal gap is utilized. The SkipRail Splices will provide a bonding path between rows of PV modules, so that one Ground Lug per array is necessary for earth ground. If a thermal break is left between two sections or Rail, the Multi-Clamps will provide a bond path across the two Rails through the PV module frame.



Pegasus Rail System - Bond Path to Ground

Using Enphase Products

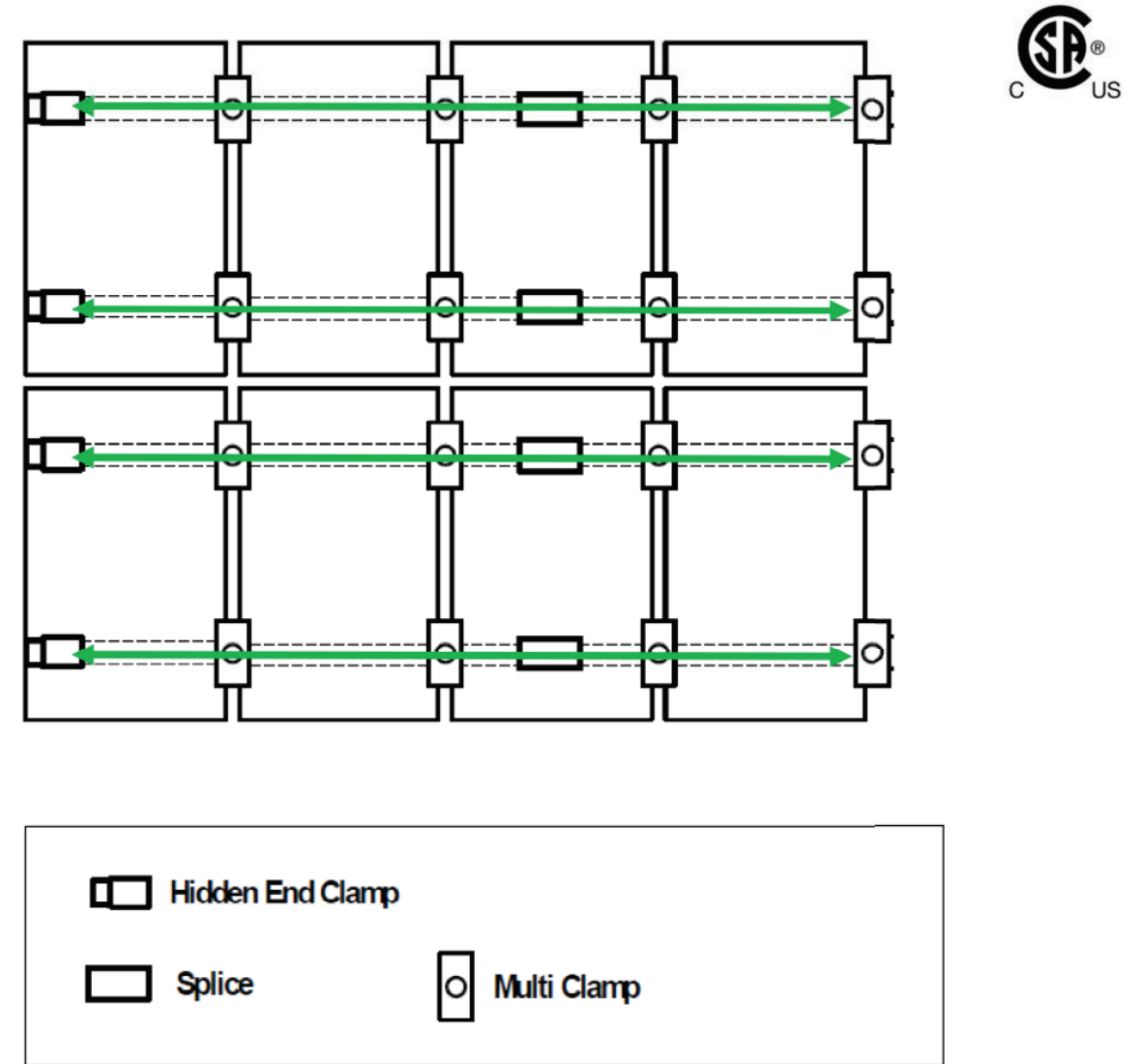

Multi-Clamps bond adjacent PV modules to one another and to the Rail. The Splice provides a bond connection between two Rail sections, including when a 1" thermal gap is utilized. The MLPE Mount creates a bond connection to the MLPE. When using Enphase products, Ground Lug, N-S Bonding Jumpers, or other equipment ground conductors (EGC) are not required, and the use of the Enphase products satisfies the UL2703 bonding and grounding requirements.

Compatible Enphase products:

- Microinverters M250-72, M250-60, M215-60, C250-72; with Engage cables ETXX-240, ETXX-208, ETXX-277



Appendix A - Compatible PV Mod-

Pegasus Rail System may be used to ground a PV module complying with UL 2703 only when the specific module has been evaluated for grounding and/or mounting in compliance with this installation manual. Unless otherwise specified, "xxx" refers to the power rating of the PV module. Both black & silver frames are included in the UL2703 listing.



Manufacturer	Model
Auxin	AXN6M612Txxx
Aptos	DNA-144-BF26-xxxW; DNA-144-MF26-xxxW; DNA-120-BF26-xxxW; DNA-120-MF26-xxxW; DNA-120-MF10-xxxW; DNA-120-BF10-xxxW; DNA-108-BF10-xxxW; DNA-108-MF10-xxxW
Axitec	AC-xxxM/156-60S; AC-xxxM/60S; AC-xxxMH/120S; AC-xxxMH/144S
Boviet	BVM6610M-xxx; BVM6610P-xxx
Canadian Solar	CS1H-xxxMS; CS1K-xxxMS; CS1Y-xxxMS; CS3K-xxxMS; CS3U-xxxMS; CS6K-xxxMS; CS6K-xxxP; CS6U-xxxM; CS6U-xxxP; CS6X-xxxM; CS6X-xxxP; BiHiKu CS3W-xxxMB-AG; CS3L-xxxMS; CS6R-xxxMS; CS3W-xxxPB-AG; CS3W-xxxP; CS3W-xxxMS; CS3L-xxxP; CS3L-xxxMS; CS3N-xxxMS; CS6W-xxxMB-AG; CS7N-xxxMB-AG
CertainTeed	CTxxxHC11-04; CTxxxM10-02; CTxxxM11-02; CTxxxM11-03; CTxxxHC00-04; CTxxxHC12-06; CTxxxHC11-06
Chint Solar	CHSM6612M-xxx
Freedom Forever	FF-MP-BBB-xxx
Hansol	HSxxxTD-AN3
Heliene	Heliene20M xxx; Heliene36M xxx; Heliene36P xxx; Heliene60M xxx; Heliene60P xxx; Heliene72M Bifacial xxx; Heliene72P xxx; Heliene96M xxx Bifacial; Heliene96M xxx; Heliene 96P xxx; HSPE-144M M6 HC Bifacial xxx; HSPE 120M M6 HC Monofacial xxx; 144HC-M10-Bifacial; 460-144M-HC-M6
Hyundai	HiD-SxxxRG(BK); HiS-MxxxRG; HiS-SxxxKI; HiS-SxxxRG; HiS-SxxxRG(BK); HiS-SxxxRI; HiS-SxxxTI; HIA-SxxxHI
JA Solar	JAM72S01-xxx/PR; JAP72S01-xxx/SC; JAM72D20-xxx/MB
Jinko	JKMxxxM-60; JKMxxxM-60B; JKMxxxM-60BL; JKMxxxM-60HBL; JKMxxxM-60HL; JKMxxxM-60L; JKMxxxM-60V; JKMxxxM-72; JKMxxxM-72HL-V; JKMxxxM-72H-V; JKMxxxM-72-V; JKMxxxP-60; JKMxxxPP-60; JKMxxxM-6RL3; JKMxxxM-6RL3-B; JKMxxxM-7RL3-TV
LG	LGN1K-G4; LGS1C-A5; LGxxxA1C-A5; LGxxxE1K-A5; LGxxxN1C-A3; LGxxxN1C-A5; LGxxxN1C-B3; LGxxxN1C-G3; LGxxxN1C-G4; LGxxxN1C-V5; LGxxxN1C-Z4; LGxxxN1K-A5; LGxxxN1K-G4; LGxxxN1K-V5; LGxxxN1K-Z4; LGxxxN2T-A5; LGxxxN2W-A5; LGxxxN2W-V5; LGxxxN2W-L5; LGxxxQ1C-A5; LGxxxQ1C-V5; LGxxxQ1K-A5; LGxxxQ1K-V5; LGxxxS1C-A5; LGxxxS2W-A5; LGxxxN1K-L5; LGxxxNIC-N5; LGxxxM1K-A6; LGxxxN1K-B6; LGxxxQ1C-A6; LGxxxQAC-A6; LGxxxQAK-A6; LGxxxM1C-A6; LGxxxN2W-E6; LGxxxN2T-E6; LGxxxN1K-E6; LGxxxN3K-V6; LGxxxN1C-A6
Longi	LR6-60BP-xxx; LR6-60HPB-xxx; LR6-60HPH-xxx; LR6-60PB-xxx; LR6-60PE-xxx; LR6-60-xxx; LR4-60HPH-xxxM; LR4-HPB-xxxM; LR4-72HPH-xxxM; LR4-72HBD-xxxM; LR5-54HPH-xxxM; LR5-72HBD-xxxM
Maxeon	SPR-MAX3-xxx-COM; SPR-MAX3-xxx-BLK; SPR-MAX5-xxx-COM; SPR-MAX6-xxx-COM; SPR-X21/22-xxx-COM; SPR-MAX3-XXX-BLK-R;
Mission Solar	MSE60Axxx; MSExxxSB1A; MSExxxSO6J; MSExxxSQ5K; MSExxxSQ5T; MSExxxSQ8K; MSExxxSQ8T; MSExxxSQ9S; MSExxxSX6S; MSExxxSX6W; MSExxxSX5T; MSExxxSX5K; MSExxxSX5R; MSExxxSX6Z; MSExxxSX9R; MSExxxSX9Z
Mitrex	Mxxx-L3H; Mxxx-L3H; Mxxx-H1H; Mxxx-B1F; Mxxx-A1F
Panasonic	VBHNxxxKA01; VBHNxxxKA03; VBHNxxxSA16; VBHNxxxSA16B; VBHNxxxSA17; VBHNxxxSA17E; EVPVxxx; EVPVxxxK; EVPVxxxPK; EVPVxxxH
Philadelphia Solar	PS-M60(BF)-xxx; PS-M72(BF)-xxx
QCells	Q.Peak 265; Q.PEAK BLK-G3.1 xxx; Q.PEAK BLK-G4.1 xxx; Q.PEAK DUO BLK-G5 xxx; Q.PEAK DUO BLK-G5/SC xxx; Q.PEAK DUO BLK-G6+ xxx; Q.PEAK DUO G6+ xxx AC ENP IQ7+; Q.PEAK DUO BLK G9+ xxx; Q.PEAK DUO L-G5.2 xxx; Q.PEAK DUO L-G5.3 xxx; Q.PEAK DUO-G5 xxx; Q.PEAK DUO-G5/SC xxx; Q.PEAK DUO-G7 xxx; Q.PEAK G4.1 xxx; Q.PEAK G4.1/ Max xxx; Q.PEAK G4.1/SC xxx; Q.PEAK G4.1/TAA xxx; Q.PEAK L-G4.2 xxx; Q.PLUS BFR G4.1 xxx; Q.PLUS BFR-G4.1/TAA xxx; Q.PLUS L-G4.1 xxx; Q.PLUS L-G4.2 xxx; Q.PLUS L-G4.2/TAA xxx; Q.PRO BFR-G4.1 xxx; Q.PEAK DUO L-G8.2 xxx; Q.PEAK DUO BLK-G8 xxx; Q.PEAK DUO BLK-G8+ xxx; Q.PEAK DUO BLK ML G9 xxx; Q.PEAK DUO BLK ML G9+ xxx; Q.PEAK DUO BLK-G10 xxx; Q.PEAK DUO BLK-G10+ xxx; Q.PEAK DUO ML-G10+; Q.PEAK DUO BLK ML-G10.a+; Q.PEAK Duo XL 10.d/BFG; Q.PEAK DUO-G10 xxx; Q.PEAK DUO-G10+ xxx; Q.PEAK DUO-G10.a xxx; Q.PEAK DUO-G10.a+ xxx; Q.PEAK DUO BLK-G10.a xxx; Q.PEAK DUO BLK-G10.a+ xxx; Q.PEAK DUO ML-G10 xxx; Q.PEAK DUO ML-G10.a xxx; Q.PEAK DUO ML-G10.a+ xxx; Q.PEAK DUO BLK ML-G10 xxx; Q.PEAK DUO BLK ML-G10+ xxx; Q.PEAK DUO BLK ML-G10.a xxx; Q.PEAK Duo ML-G10+ /t xxx; Q.Trion BLK M-G2+ xxx; Q.Trion M-G2+ xxx;
REC	RECxxxNP; RECxxxNP Black; RECxxxPE; RECxxxPE 72; RECxxxPE(BLK); RECxxxTP; RECxxxTP BLK; RECxxxTP2; RECxxxTP2 BLK; RECxxxTP2 BLK Q2; RECxxxTP2 BLK Q2; RECxxxTP2 BLK2; RECxxxTP2M; RECxxxTP2S 72; RECxxxAA; RECxxxAA Black; RECxxxAA 72; RECxxxNP3; RECxxxNP3 Black; RECxxxNP2; RECxxxNP2 Black; RECxxxAA Pure; RECxxxAA Pure-R
S-Energy	SNxxxM-10; SNxxxM-10(B); SNxxxM-10T; SC20-60MBE-xxxM
SEG	SEG-xxx-BMA-HV; SEG-xxx-BMA-TB; SEG-xxx-BMA-BG; SEG-xxx-BMB-HV; SEG-xxx-BMA-BG; SEG-xxx-BMD-HV; SEG-xxx-BMD-TB; SEG-xxx-BMB-BG; SEG-xxx-BMC-HV; SEG-xxx-BMC-TB; SEG-xxx-BMC-BG
Silfab	SILxxxBL; SILxxxNL; SLAxxxM; SLAxxxM; SLGxxxM; SSAxxxM; SIL-xxxNX; SIL-xxxHL; SIL-xxxNX; SIL-xxxBK; SIL-xxxHC; SIL-xxxHC+; SIL-xxxBG; SIL-xxxHN; SIL-xxxHM
Solar4America	S4A410 72MH5BB, S4A33 60MH5BB



Appendix B - SkipRail Compatible PV Modules

The following PV modules are structurally compatible with the SkipRail installation method.

Manufacturer	Model
Aptos	DNA-144-BF26-xxxW; DNA-144-MF26-xxxW; DNA-120-BF26-xxxW; DNA-120-MF26-xxxW; DNA-120-MF10-xxxW; DNA-120-BF10-xxxW; DNA-108-BF10-xxxW; DNA-108-MF10-xxxW
Jinko	JKMxxxM-72HL-V; JKMxxxM-72HBL-V; JKMxxxM-6RL3-V; JKMxxxM-6RL3-B
Longi	LR6-60BP-xxx; LR6-60HPB-xxx; LR6-60HPH-xxx; LR6-60PB-xxx; LR6-60PE-xxx; LR6-60-xxx; LR4-60HPH-xxxM; LR4-60HPB-xxxM; LR4-72HPH-xxxM; LR4-72HBD-xxxM; LRS-54HPH-xxxM; LRS-54HPB-xxxM; LRS-54HABB-xxxM; LRS-54HABD-xxxM; LRS-66HPH-xxxM
QCells	Q.PEAK DUO BLK-G10 xxx; Q.PEAK DUO BLK-G10+ xxx; Q.PEAK DUO ML-G10+; Q.PEAK DUO BLK ML-G10.a+; Q.PEAK Duo XL 10.d/BFG; Q.PEAK DUO-G10 xxx; Q.PEAK DUO-G10+ xxx; Q.PEAK DUO-G10.a xxx; Q.PEAK DUO-G10.a+ xxx; Q.PEAK DUO ML-G10 xxx; Q.PEAK DUO ML-G10.a xxx; Q.PEAK DUO ML-G10.a+ xxx; Q.PEAK DUO BLK ML-G10 xxx; Q.PEAK DUO BLK ML-G10+ xxx; Q.PEAK DUO BLK ML-G10.a xxx; Q.PEAK Duo ML-G10+ /t xxx
Mission Solar	MSExxxSX6W; MSExxxSX5T; MSExxxSX5K; MSExxxSX6Z; MSExxxSX6S; MSExxxSX9R; MSExxxSX9Z
REC	RECxxxNP; RECxxxNP Black; RECxxxPE; RECxxxPE 72; RECxxxPE(BLK); RECxxxTP; RECxxxTP BLK; RECxxxTP2; RECxxxTP2 BLK; RECxxxTP2 BLK Q2; RECxxxTP2 BLK2; RECxxxTP2M; RECxxxTP2S 72; RECxxxAA; RECxxxAA Black; RECxxxAA 72; RECxxxNP3; RECxxxNP3 Black; RECxxxNP2; RECxxxNP2 Black; RECxxxAA Pure; RECxxxAA Pure-R
SEG Solar	SEG-xxx-BTB-BG; SEG-xxx-BTD-BG; SEG-xxx-BMB-HV; SEG-xxx-BMD-HV; SEG-xxx-BMB-BG; SEG-xxx-BMD-BG; SEG-xxx-BMB-TB; SEG-xxx-BMD-TB
Silfab	SIL-xxxHC
URE Co.	FBMxxxMFG; FBMxxxMFG-BB
Waaree	WSMDi-xxx
ZN Shine	ZXM7-UHLDD144-xxx/N; ZXM7-SHLDD144-xxx/M; ZXM6-NHLDD144xxx/M



Eaton general duty cartridge fuse safety switch

DG222NRB

UPC:782113144221

Dimensions:

- **Height:** 14.37 IN
- **Length:** 7.35 IN
- **Width:** 8.4 IN

Weight:10 LB

Notes:Maximum hp ratings apply only when dual element fuses are used. 3-Phase hp rating shown is a grounded B phase rating, UL listed.

Warranties:

- Eaton Selling Policy 25-000, one (1) year from the date of installation of the Product or eighteen (18) months from the date of shipment of the Product, whichever occurs first.

Specifications:

- **Type:** General duty, cartridge fused
- **Amperage Rating:** 60A
- **Enclosure:** NEMA 3R
- **Enclosure Material:** Painted galvanized steel
- **Fuse Class Provision:** Class H fuses
- **Fuse Configuration:** Fusible with neutral
- **Number Of Poles:** Two-pole
- **Number Of Wires:** Three-wire
- **Product Category:** General duty safety switch
- **Voltage Rating:** 240V

Supporting documents:

- [Eatons Volume 2-Commercial Distribution](#)
- [Eaton Specification Sheet - DG222NRB](#)

Certifications:

- UL Listed

Product compliance: No Data



Eaton general duty non-fusible safety switch

DG222URB

UPC:782113144238

Dimensions:

- **Height:** 14.38 IN
- **Length:** 7.38 IN
- **Width:** 8.69 IN

Weight:9 LB

Notes:WARNING! Switch is not approved for service entrance unless a neutral kit is installed.

Warranties:

- Eaton Selling Policy 25-000, one (1) year from the date of installation of the Product or eighteen (18) months from the date of shipment of the Product, whichever occurs first.

Specifications:

- **Type:** Non-fusible, single-throw
- **Amperage Rating:** 60A
- **Enclosure:** NEMA 3R, Rainproof
- **Enclosure Material:** Painted galvanized steel
- **Fuse Configuration:** Non-fusible
- **Number Of Poles:** Two-pole
- **Number Of Wires:** Two-wire
- **Product Category:** General duty safety switch
- **Voltage Rating:** 240V

Supporting documents:

- [Eatons Volume 2-Commercial Distribution](#)
- [Eaton Specification Sheet - DG222URB](#)

Certifications:

- UL Listed

Product compliance: No Data



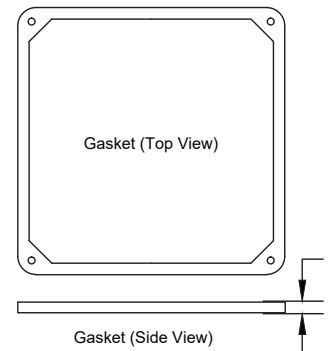
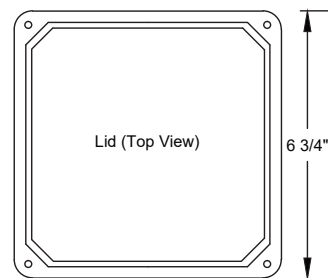
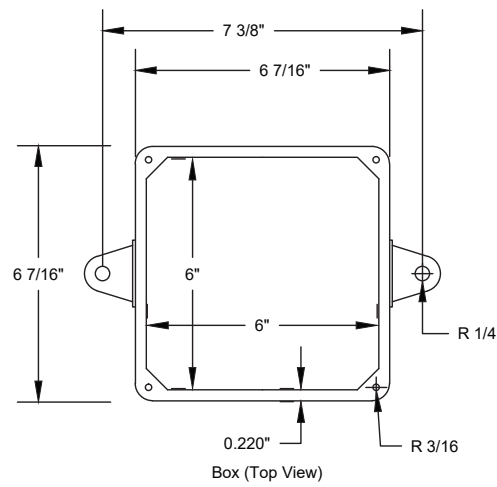
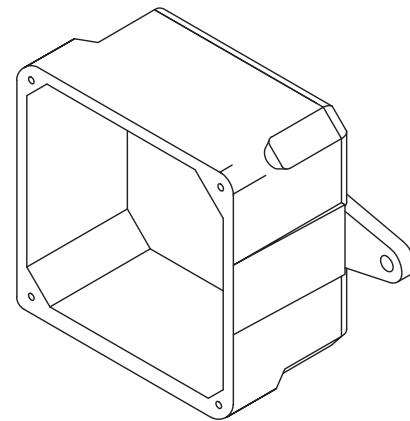
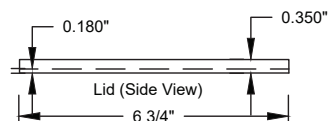
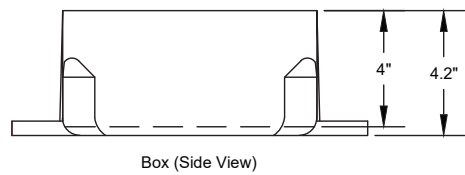

UL Listed
 Marine Listed
 UL File # E205935 (QCUP)
 UL Control # 92CM
 Material is Rigid PVC
 132 cu in Volume (2163 cu cm)
 Screws are Zinc Plated Steel
 Gasket is neoprene

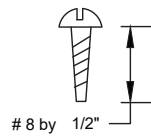

CANTEX INC. Fort Worth, TEXAS		
Junction Box 6 x 6 x 4		
Drawn By: O.M.	Date: 6/19/17	5133710

Project information

Installer	Freedom Solar Power	Project Name	Curtis Collins
		Project Number	114123
Project Address	728 Collins Road, Lillington, NC 27546 USA	AHJ/ASCE	Harnett County/7-16
		Wind / Exp. Cat. / Snow	115.0mph / B / 15 psf

Equipment Type

Summary

Module	REC REC420AA-Pure-R	Total modules	22
Inverter	-	Total watts	9240 W
Battery	--	Total Attachments	43

Location preview

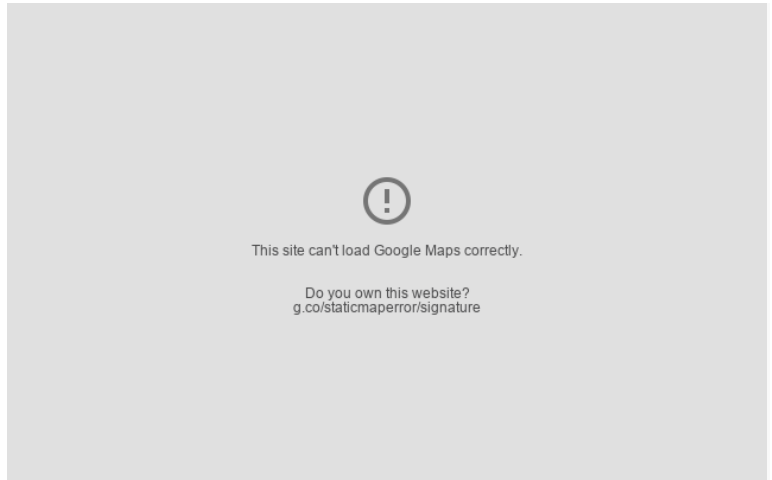
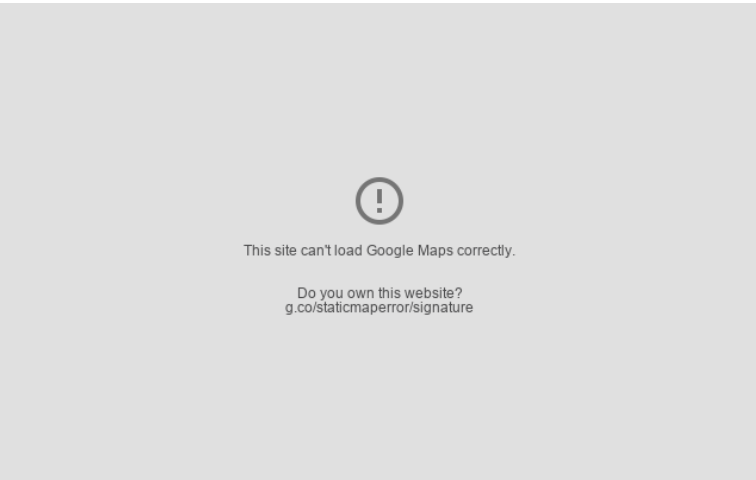

Arrays

Array 1		Roof Type: Gable Roof Material: Comp	SkipRail: Yes Roof Slope: 34°
Array 2		Roof Type: Gable Roof Material: Comp	SkipRail: Yes Roof Slope: 34°
Array 3		Roof Type: Gable Roof Material: Comp	SkipRail: Yes Roof Slope: 34°
Array 4		Roof Type: Gable Roof Material: Comp	SkipRail: Yes Roof Slope: 33°

Array 1 SkipRail

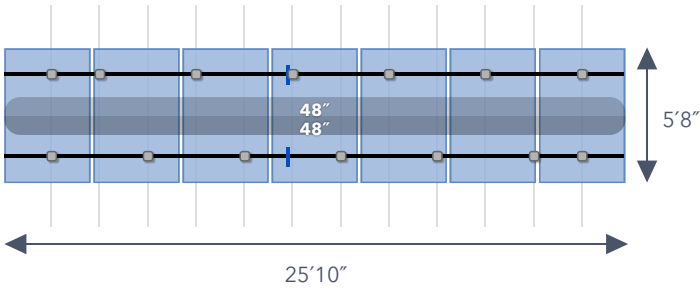

Zones:

- 1
- 2
- 3

Details

Roof Type: **34° Comp Gable**
 Rafter Spacing: **24.0"**
 SkipRail: **Yes**
 Use Scrap Rail: **Yes**

Hidden End Clamp: **Yes**
 Attachment Type: **Instaflash**
 Rail: **0 x 7ft, 4 x 14ft**

Layout

Panels: **7**

Panel Size: **68.11" x 44.02" x 40mm**

Design Notes

System Weight: **378.9 lbs**
 Attachments: **14**

System Weight/Attachment: **27.1 lbs**
 Total Area: **458 sqft**

Engineering

Max span values for SkipRail system are displayed on the diagram

Array 2 SkipRail

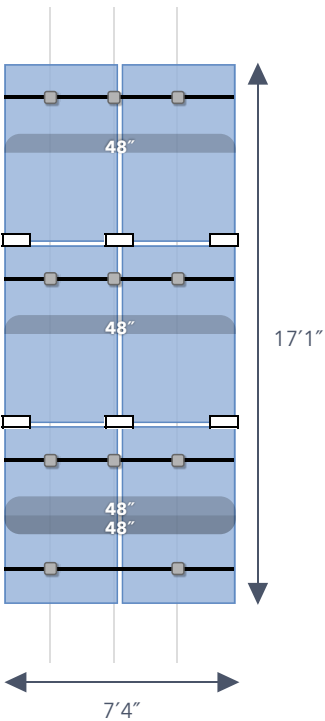

Zones:

- 1
- 2
- 3

Details

Roof Type: **34° Comp Gable**
 Rafter Spacing: **24.0"**
 SkipRail: **Yes**
 Use Scrap Rail: **Yes**

Hidden End Clamp: **Yes**
 Attachment Type: **Instaflash**
 Rail: **0 x 7ft, 4 x 14ft**

Layout

Panels: **6**

Panel Size: **68.11" x 44.02" x 40mm**

Design Notes

System Weight: **331.2 lbs**
 Attachments: **11**

System Weight/Attachment: **30.1 lbs**
 Total Area: **458 sqft**

Engineering

Max span values for SkipRail system are displayed on the diagram

Array 3 SkipRail

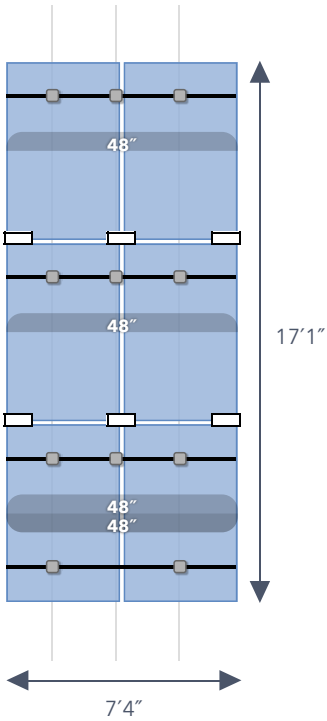

Zones:

- 1
- 2
- 3

Details

Roof Type: **34° Comp Gable**
 Rafter Spacing: **24.0"**
 SkipRail: **Yes**
 Use Scrap Rail: **Yes**

Hidden End Clamp: **Yes**
 Attachment Type: **Instaflash**
 Rail: **0 x 7ft, 4 x 14ft**

Layout

Panels: **6**

Panel Size: **68.11" x 44.02" x 40mm**

Design Notes

System Weight: **331.2 lbs**
 Attachments: **11**

System Weight/Attachment: **30.1 lbs**
 Total Area: **458 sqft**

Engineering

Max span values for SkipRail system are displayed on the diagram

Array 4 SkipRail

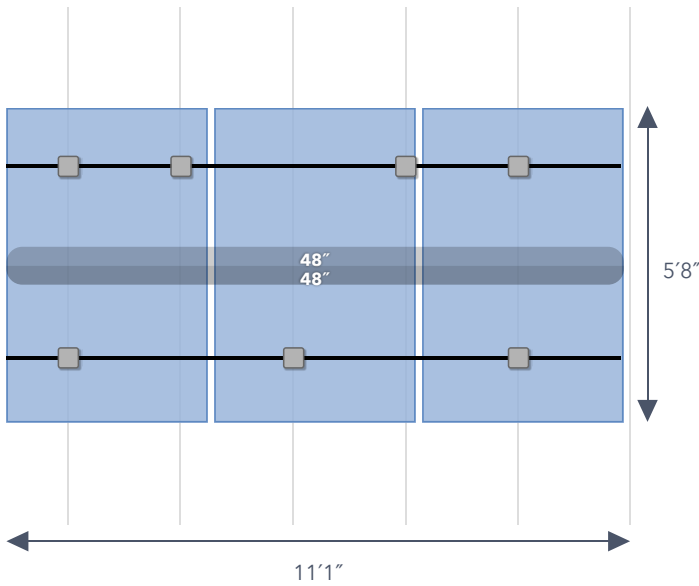

Zones:

- 1
- 2
- 3

Details

Roof Type: **33° Comp Gable**
 Rafter Spacing: **24.0"**
 SkipRail: **Yes**
 Use Scrap Rail: **Yes**

Hidden End Clamp: **Yes**
 Attachment Type: **Instaflash**
 Rail: **0 x 7ft, 2 x 14ft**

Layout

Panels: **3**

Panel Size: **68.11" x 44.02" x 40mm**

Design Notes

System Weight: **165.4 lbs**
 Attachments: **7**

System Weight/Attachment: **23.6 lbs**
 Total Area: **458 sqft**

Engineering

Max span values for SkipRail system are displayed on the diagram

Bill of Materials

Part Info	Array 1	Array 2	Array 3	Array 4	Spares	Total QTY
PSR-B168 Pegasus Rail - Black 168"	4	4	4	2	-	14
PSR-SPLS Pegasus - Bonded Structural Splice	2	-	-	-	-	2
PSR-MCB Pegasus - Multi-Clamp - Mid/End 30-40mm - Full Black	12	4	4	4	-	24
PSR-HEC Pegasus - Hidden End Clamp	4	8	8	4	-	24
PSR-SRC Pegasus - SkipRail Clamp	-	6	6	-	-	12
PSR-MLP Pegasus - MLPE Mount	7	6	6	3	-	22
PSR-LUG Pegasus - Ground Lug	1	1	1	1	-	4
PSR-WMC Pegasus - Wire Management Clip	11	9	9	5	-	34
PSR-CBG Pegasus - Cable Grip	2	1	1	1	-	5
PSR-CAP Pegasus - End Cap	4	8	8	4	-	24
PIF-RBDT Pegasus InstaFlash - Black - Dovetail T-bolt	14	11	11	7	-	43