

NEW PHOTOVOLTAIC SYSTEM 6.075kW DC / 5.000kW AC
94 MARY ROBERTSON STREET, DUNN, NC 28334

AHJ

NC-COUNTYOFHARNETT

UTILITY

DUKEENERGY(PROGRESSENERGYCAROLINASINC)

CODESANDSTANDARDS

ELECTRICCODE:NEC2017WITHNCAMENDMENTS
 FIRECODE:NCFC2018
 BUILDINGCODE:NCBC2018
 RESIDENTIALCODE:NCRC2018
 WIND SPEED: 120 MPH
 SNOWLOAD:20 PSF

SCOPE OF WORK

(N) 6.075kW DC / 5.000kW AC ROOF MOUNT PV SYSTEM
 (15) HANWHA QCELLS Q.PEAK DUO BLK ML-G10+ 405 (405W) MODULES
 (1) SOLAREEDGE TECHNOLOGIES SE5000H-US (240V) INVERTER
 (15) SOLAREEDGE S440 POWER OPTIMIZERS

STRUCTURAL NOTES :1. THESE PLANS ARE STAMPED FOR STRUCTURAL CODE COMPLIANCE OF THE ROOF FRAMING SUPPORTING THE PROPOSED PV INSTALLATION ONLY.2. THESE PLANS ARE NOT STAMPED FOR WATER LEAKAGE.3. PV MODULES, RACKING, AND ATTACHMENT COMPONENTS MUST FOLLOW MANUFACTURER GUIDELINES AND REQUIREMENTS.4. PLEASE SEE THE ACCOMPANYING STRUCTURAL CALCULATIONS REPORT FOR ADDITIONAL INFORMATION.5. PRIOR TO COMMENCEMENT OF WORK, THE SOLAR INSTALLER SHALL VERIFY THE ROOF FRAMING INFO BEFORE INSTALLATION AND NOTIFY THE E.O.R. IF THERE IS ANY INCONSISTENCY BETWEEN SITE VERIFICATION AND FOLLOWING: 2x4 RAFTERS @ 24" OC SPACING WITH MAX UNSUPPORTED SPAN EQUAL OR LESS THAN 10 FT.

VICINITY MAP

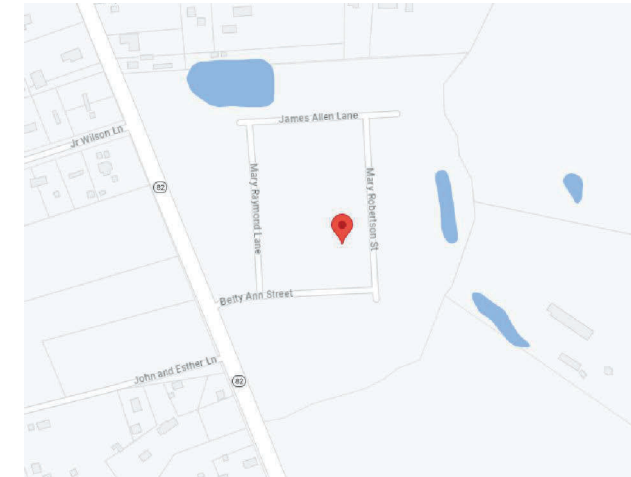

CONTRACTOR INFORMATION



PALMETTO SOLAR
 ADDRESS: 997 MORRISON DRIVE, SUITE 200, CHARLESTON, SC 29403
 PHONE NUMBER: (855) 339-1831

CUSTOMER INFORMATION

NAME: EDUARDO CARRANZA
 ADDRESS: 94 MARY ROBERTSON STREET, DUNN, NC 28334
 COORDINATES: 35.300304, -78.666147
 APN: 0596946308000
 6.075kW DC / 5.000kW AC ROOF MOUNT PV SYSTEM

GENERAL NOTES

1.MODULES ARE LISTED UNDER UL 1703 / UL 61730 AND CONFORM TO THE STANDARDS.
 2.INVERTERS ARE LISTED UNDER UL 1741 AND CONFORM TO THE STANDARDS.
 3.DRAWINGS ARE DIAGRAMMATIC, INDICATING GENERAL ARRANGEMENT OF THE PV SYSTEM. ACTUAL SITE CONDITIONS MAY VARY.
 4.WORKING CLEARANCES AROUND THE NEW PV ELECTRICAL EQUIPMENT SHALL BE MAINTAINED IN ACCORDANCE WITH NEC 110.26.
 5.ALL GROUND WIRING CONNECTED TO THE MAIN SERVICE GROUNDING IN MAIN SERVICE PANEL / SERVICE EQUIPMENT.
 6.ALL CONDUCTORS SHALL BE 600V, 90°C STANDARD COPPER UNLESS OTHERWISE NOTED.
 7.WHEN REQUIRED, A LADDER SHALL BE IN PLACE FOR INSPECTION IN COMPLIANCE WITH OSHA REGULATIONS.
 8.THE SYSTEM WILL NOT BE INTERCONNECTED BY THE CONTRACTOR UNTIL APPROVAL FROM UTILITY IS RECEIVED.
 9.ROOF ACCESS POINT SHALL BE LOCATED IN AREAS THAT DO NOT REQUIRE THE PLACEMENT OF GROUND LADDERS OVER OPENINGS SUCH AS WINDOWS OR DOORS, AND LOCATED AT STRONG POINTS OF BUILDING CONSTRUCTION WHERE THE ACCESS POINT DOES NOT CONFLICT WITH OVERHEAD OBSTRUCTIONS SUCH AS TREES, WIRES OR SIGNS.

10.PV ARRAY COMBINER / JUNCTION BOX PROVIDES TRANSITION FROM ARRAY WIRING TO CONDUIT WIRING.
 11.RACKING SYSTEM SHALL BE LISTED TO UL 2703.
 12.FIRE RATING OF EXISTING ROOF ASSEMBLY SHALL BE MAINTAINED WITH ADDITIONAL OF PHOTOVOLTAIC SYSTEM.

SHEET CATALOG

- PV-1** COVER SHEET
- PV-2** SITE PLAN-1
- PV-2.1** SITE PLAN-2
- PV-3** MOUNTING DETAILS
- PV-3.1** STRUCTURAL DETAILS
- PV-4** SINGLE LINE DIAGRAM
- PV-4.1** ELECTRICAL CALCULATIONS
- PV-5** PLACARDS
- SS** SPEC SHEETS

METER NUMBER: 348 794 779



PROJECT ID	AUR-87459
DATE	10/17/2023
CREATED BY	NC
SIGNATURE	

COVER SHEET
PV-1

SCOPE OF WORK

(N) 6.075kW DC / 5.000kW AC ROOF MOUNT PV SYSTEM
 (15) HANWHA QCELLS Q.PEAK DUO BLK ML-G10+ 405 (405W) MODULES
 (1) SOLAREEDGE TECHNOLOGIES SE5000H-US (240V) INVERTER
 (15) SOLAREEDGE S440 POWER OPTIMIZERS
 TOTAL ARRAY AREA = 316.81 SQ.FT
 TOTAL ROOF AREA = 1570 SQ.FT
 % ARRAY AREA IN ROOF = 20.17%

LEGEND

- PROPERTY LINE
- FENCE AND GATE LINE

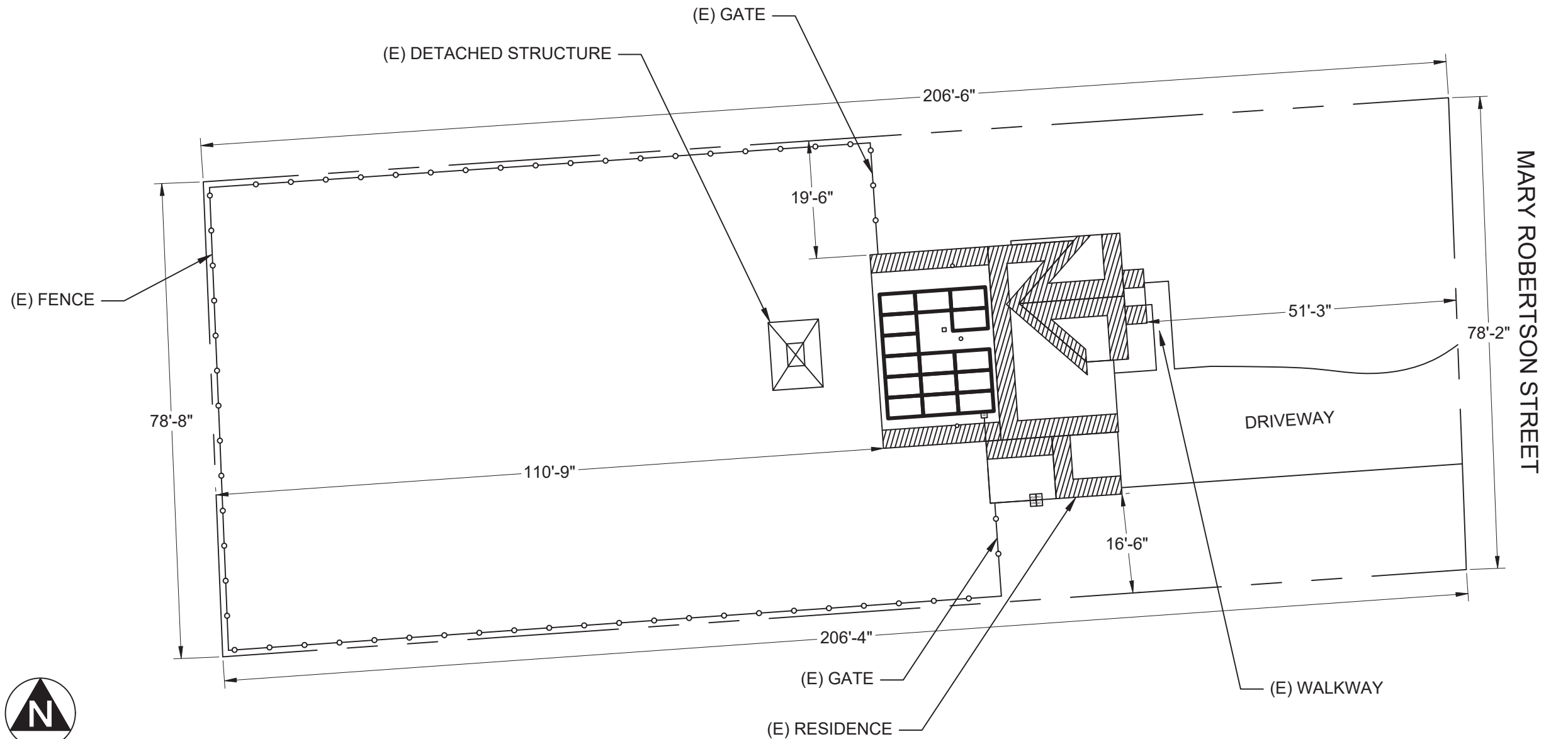

SCALE: 1"=20'-0"

CONTRACTOR INFORMATION



PALMETTO SOLAR
 ADDRESS: 997 MORRISON DRIVE,
 SUITE 200, CHARLESTON, SC 29403
 PHONE NUMBER: (855) 339-1831

CUSTOMER INFORMATION

NAME: EDUARDO CARRANZA
 ADDRESS: 94 MARY ROBERTSON
 STREET, DUNN, NC 28334
 COORDINATES: 35.300304, -78.666147
 APN: 0596946308000
 6.075kW DC / 5.000kW AC ROOF
 MOUNT PV SYSTEM



PROJECT ID	AUR-87459
DATE	10/17/2023
CREATED BY	NC
SIGNATURE	

SITE PLAN-1
 PV-2

SCOPE OF WORK

(N) 6.075kW DC / 5.000kW AC ROOF MOUNT PV SYSTEM
 (15) HANWHA QCELLS Q.PEAK DUO BLK ML-G10+ 405 (405W) MODULES
 (1) SOLAREEDGE TECHNOLOGIES SE5000H-US (240V) INVERTER
 (15) SOLAREEDGE S440 POWER OPTIMIZERS
 TOTAL ARRAY AREA = 316.81 SQ.FT
 TOTAL ROOF AREA = 1570 SQ.FT
 % ARRAY AREA IN ROOF = 20.17%

CONTRACTOR INFORMATION



PALMETTO SOLAR
 ADDRESS: 997 MORRISON DRIVE,
 SUITE 200, CHARLESTON, SC 29403
 PHONE NUMBER: (855) 339-1831

CUSTOMER INFORMATION

NAME: EDUARDO CARRANZA
 ADDRESS: 94 MARY ROBERTSON STREET, DUNN, NC 28334
 COORDINATES: 35.300304, -78.666147
 APN: 0596946308000
 6.075kW DC / 5.000kW AC ROOF MOUNT PV SYSTEM

(N) (15) HANWHA QCELLS Q.PEAK DUO BLK ML-G10+ 405 (405W) MODULES WITH SOLAREEDGE S440 POWER OPTIMIZER UNDER EACH MODULE

(N) PHOTOVOLTAIC ARRAY ON MP-01

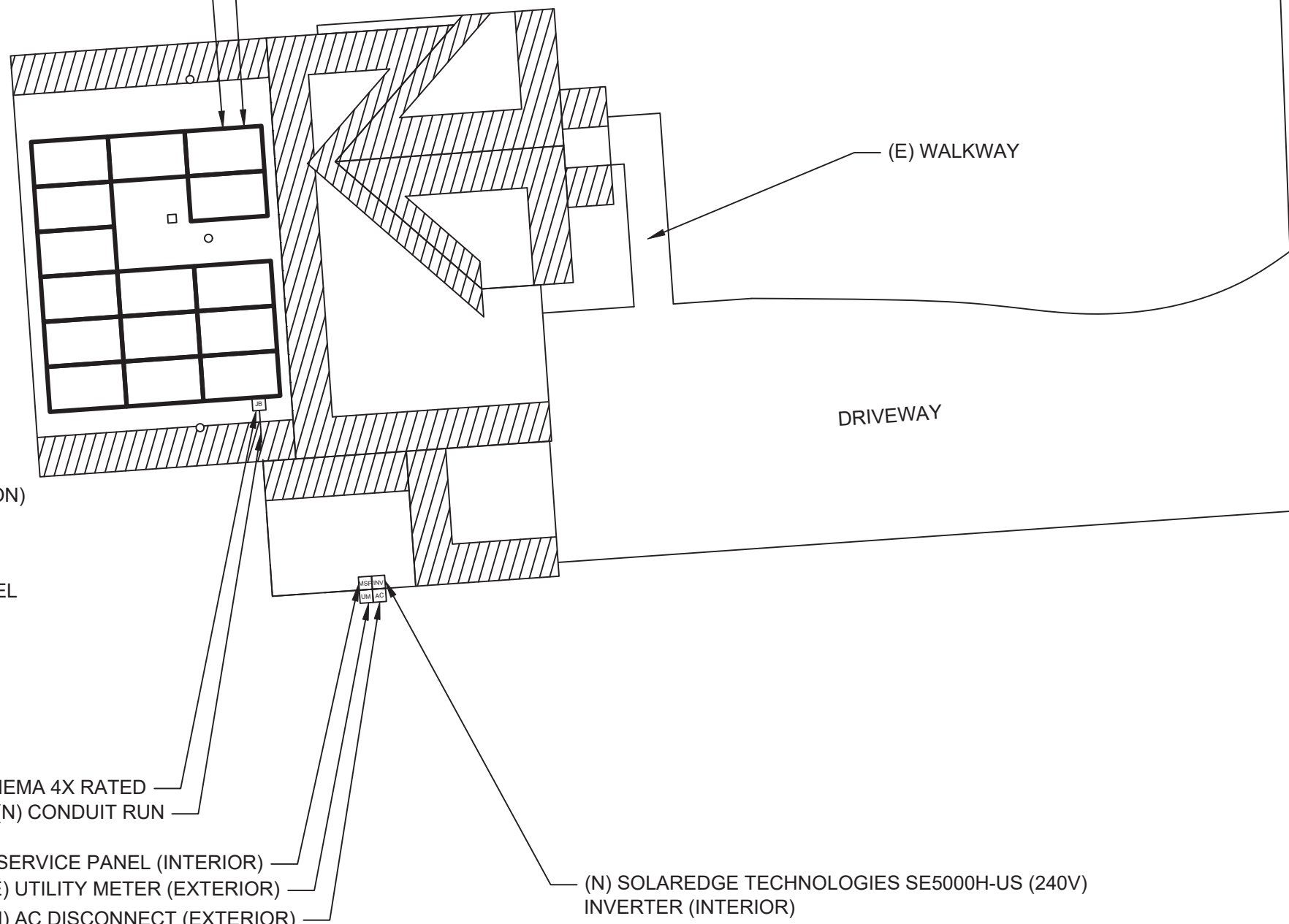

LEGEND

- SETBACK
- VENT (ROOF OBSTRUCTION)
- UTILITY METER
- MAIN SERVICE PANEL
- AC DISCONNECT
- INVERTER
- JUNCTION BOX

(N) JUNCTION BOX NEMA 4X RATED
 (N) CONDUIT RUN

(E) MAIN SERVICE PANEL (INTERIOR)
 (E) UTILITY METER (EXTERIOR)
 (N) AC DISCONNECT (EXTERIOR)

(N) SOLAREEDGE TECHNOLOGIES SE5000H-US (240V) INVERTER (INTERIOR)

SCALE: 3/32" = 1'-0"

MARY ROBERTSON STREET



PROJECT ID	AUR-87459
DATE	10/17/2023
CREATED BY	NC
SIGNATURE	

**SITE PLAN-2
 PV-2.1**

WIND SPEED: 120 MPH AND SNOW LOAD: 20 PSF

S.NO	AZIMUTH	PITCH	NO. OF MODULES	ARRAY AREA (SQ.FT)	ROOF TYPE	ATTACHMENT	ATTACHMENT QUANTITY	ROOF EXPOSURE	FRAME TYPE	FRAME SIZE	FRAME SPACING	MAX ATTACHMENT SPACING	MAX OVER HANG
MP-01	266°	18°	15	316.81	COMPOSITION SHINGLE	IRONRIDGE QUICKMOUNT L-MOUNT	34	ATTIC	RAFTERS	2" X 4"	24" O.C.	4'-0"	1'-6"

NOTE:
 1. PENETRATIONS ARE STAGGERED.
 2. TOTAL ATTACHMENTS: 34.

CONTRACTOR INFORMATION



PALMETTO SOLAR
 ADDRESS: 997 MORRISON DRIVE,
 SUITE 200, CHARLESTON, SC 29403
 PHONE NUMBER: (855) 339-1831

CUSTOMER INFORMATION

NAME: EDUARDO CARRANZA
 ADDRESS: 94 MARY ROBERTSON
 STREET, DUNN, NC 28334
 COORDINATES: 35.300304, -78.666147
 APN: 0596946308000
 6.075kW DC / 5.000kW AC ROOF
 MOUNT PV SYSTEM

- LEGEND**
- SETBACK
 - MODULE
 - RAIL
 - ATTACHMENT
 - ROOF FRAME
 - VENT (ROOF OBSTRUCTION)

(N) ARRAY MP-01
 (N) ALUMINUM RAILS
 (E) 2" X 4" RAFTERS @ 24" O.C. SPACING

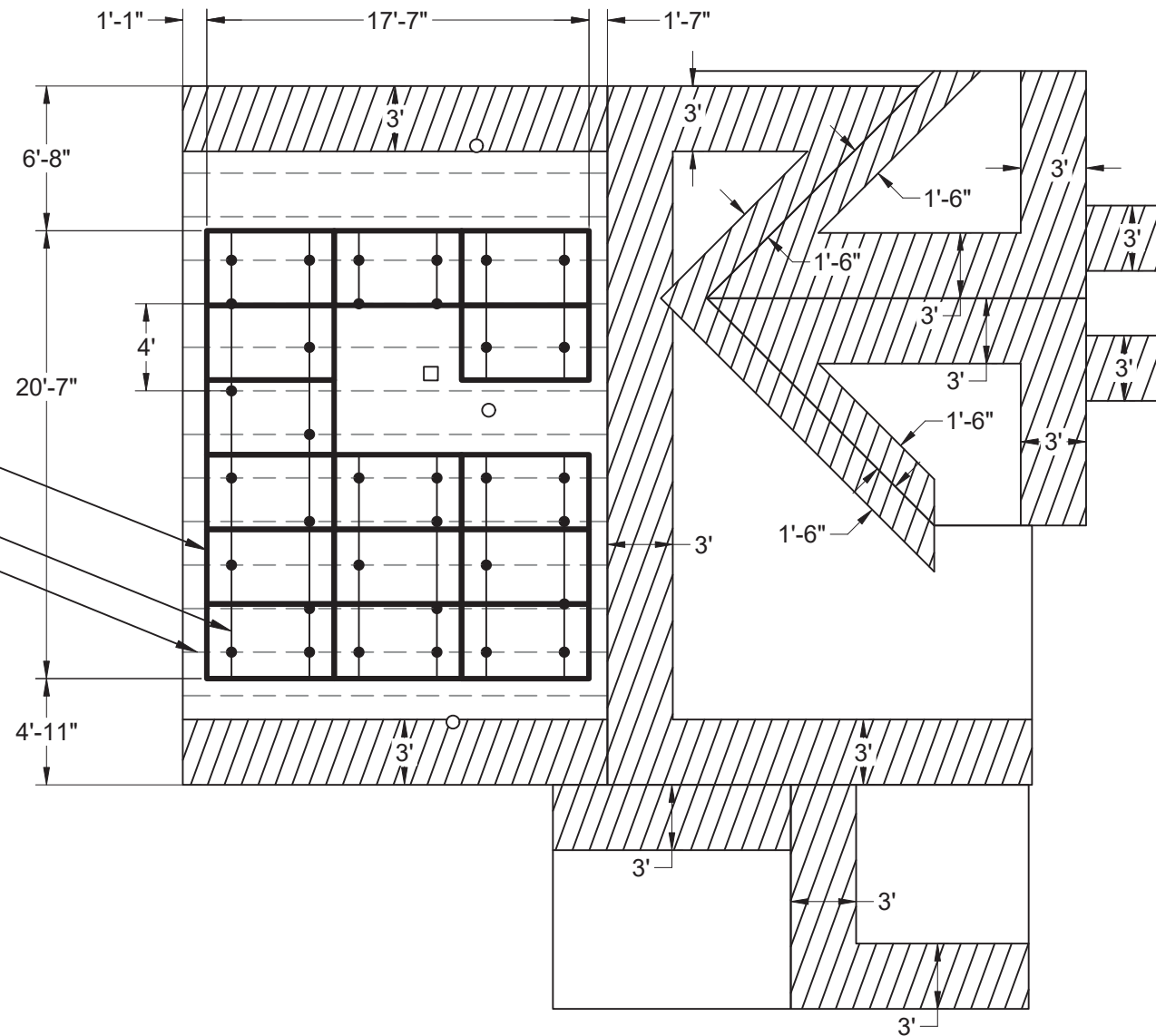

PROJECT ID	AUR-87459
DATE	10/17/2023
CREATED BY	NC
SIGNATURE	

MOUNTING DETAILS
 PV-3



SCALE: 1/8" = 1'-0"

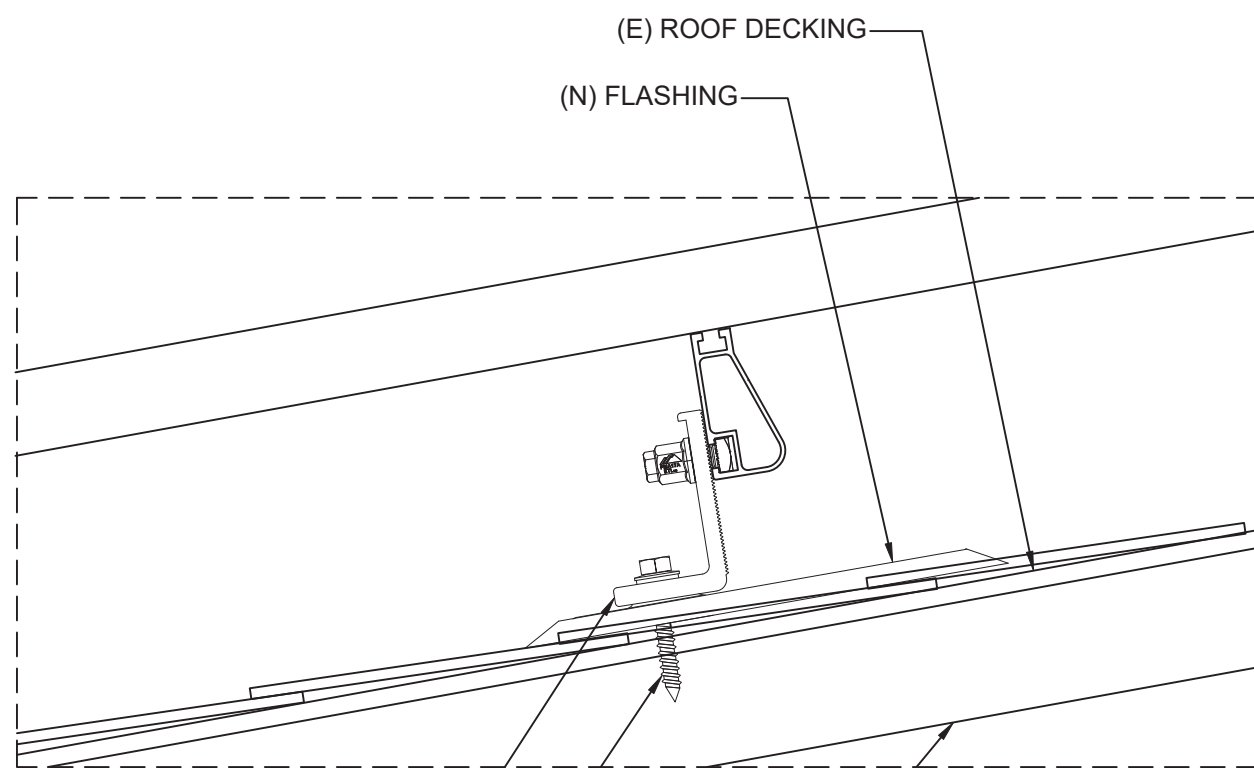
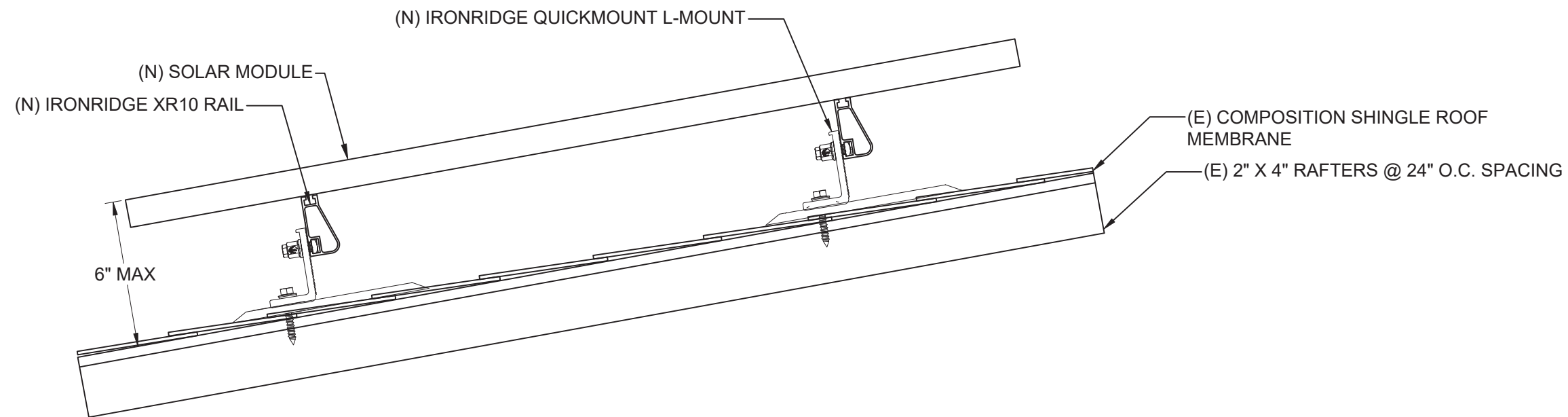

SCALE: NTS

DEAD LOAD CALCULATIONS			
BOM	QUANTITY	LBS/UNIT	TOTAL WEIGHT (LBS)
MODULES	15	48.5	727.5
MID-CLAMP	20	0.05	1
END-CLAMP	20	0.05	1
RAIL LENGTH	107	0.43	46.01
SPLICE BAR	2	0.36	0.72
IRONRIDGE QUICKMOUNT L-MOUNT	34	0.7565	25.72
OPTIMIZER	15	1.58	23.7
TOTAL WEIGHT OF THE SYSTEM (LBS)			825.65
TOTAL ARRAY AREA ON THE ROOF (SQ. FT.)			316.81
WEIGHT PER SQ. FT.(LBS)			2.6
WEIGHT PER PENETRATION (LBS)			24.28

CONTRACTOR INFORMATION



PALMETTO SOLAR
 ADDRESS: 997 MORRISON DRIVE,
 SUITE 200, CHARLESTON, SC 29403
 PHONE NUMBER: (855) 339-1831

CUSTOMER INFORMATION

NAME: EDUARDO CARRANZA
 ADDRESS: 94 MARY ROBERTSON
 STREET, DUNN, NC 28334
 COORDINATES: 35.300304, -78.666147
 APN: 0596946308000
 6.075kW DC / 5.000kW AC ROOF
 MOUNT PV SYSTEM



PROJECT ID	AUR-87459
DATE	10/17/2023
CREATED BY	NC
SIGNATURE	

STRUCTURAL DETAILS
 PV-3.1

MODULE SPECIFICATIONS	
MODEL	HANWHA QCELLS Q.PEAK DUO BLK ML-G10+ 405 (405W)
MODULE POWER @ STC	405W
OPEN CIRCUIT VOLTAGE:Voc	45.34V
MAX POWER VOLTAGE:Vmp	37.39V
SHORT CIRCUIT CURRENT:Isc	11.17A
MAX POWER CURRENT:Imp	10.83A
TEMPERATURE COEFFICIENT:Voc	-0.27%/K
MODULE DIMENSIONS: L x W x H	74" x 41.1" x 1.26"
NUMBER OF MODULES	15

INVERTER-1 SPECIFICATIONS	
MODEL	SOLAREEDGE TECHNOLOGIES SE5000H-US (240V)
POWER RATING	5000W
MAX OUTPUT CURRENT	21A
CEC WEIGHTED EFFICIENCY	99%
MAX INPUT CURRENT	13.5A
MAX DC VOLTAGE	480V
NUMBER OF INVERTER	1

OPTIMIZER CHARACTERISTICS	
MODEL	SOLAREEDGE S440 POWER OPTIMIZER
MIN INPUT VOLTAGE	8VDC
MAX INPUT VOLTAGE	60VDC
MAX INPUT CURRENT	14.5ADC
MAX OUTPUT CURRENT	15ADC
NUMBER OF OPTIMIZERS	15

CONTRACTOR INFORMATION



PALMETTO SOLAR
 ADDRESS: 997 MORRISON DRIVE, SUITE 200, CHARLESTON, SC 29403
 PHONE NUMBER: (855) 339-1831

CUSTOMER INFORMATION

NAME: EDUARDO CARRANZA
 ADDRESS: 94 MARY ROBERTSON STREET, DUNN, NC 28334
 COORDINATES: 35.300304, -78.666147
 APN: 0596946308000
 6.075kW DC / 5.000kW AC ROOF MOUNT PV SYSTEM

NOTE:
 INSULATED PIERCING TAPS USED FOR THE LINE SIDE TAP SHALL BE LISTED AND MARKED SUITABLE FOR USE ON THE LINE SIDE OF THE MAIN SERVICE PANEL IN ACCORDANCE WITH NEC 230.46.

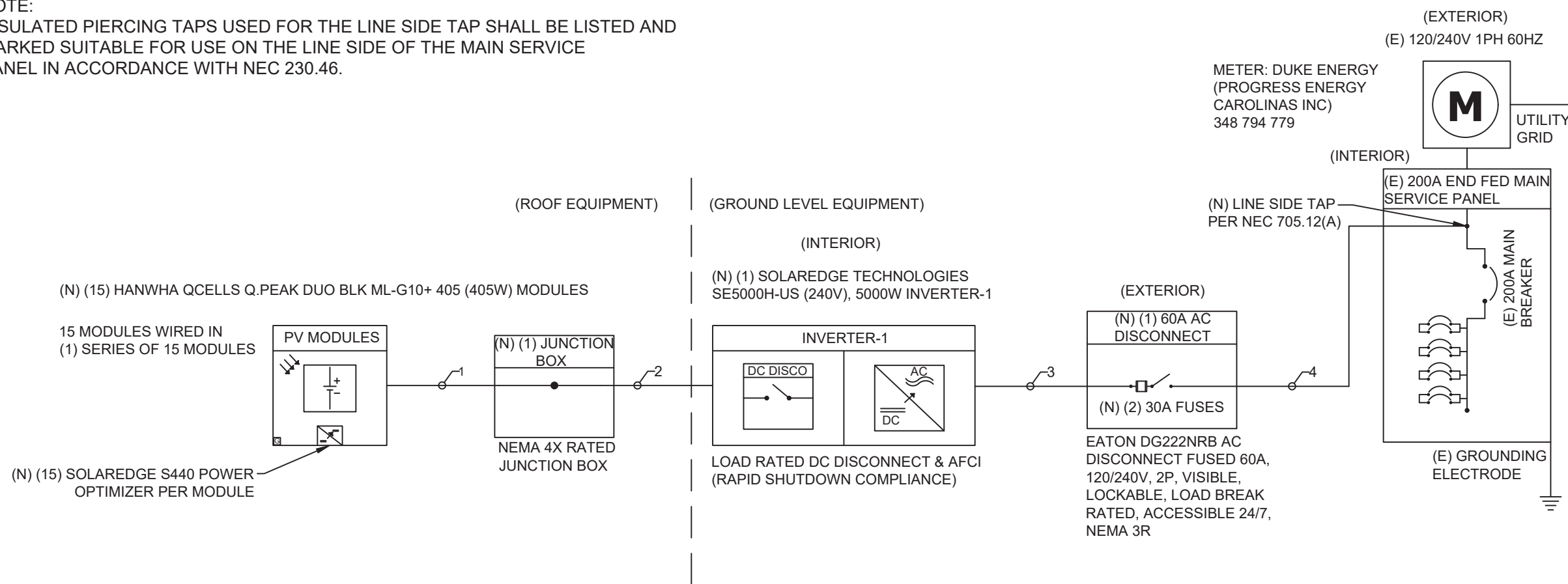

CONDUCTOR SCHEDULE				
TAG ID	CONDUIT SIZE	CONDUCTOR	NEUTRAL	GROUND
1	NONE	(2) 10 AWG PV WIRE	NONE	(1) 6 AWG BARE COPPER, EGC
2	3/4" EMT	(2) 10 AWG THHN/THWN-2, Cu	NONE	(1) 10 AWG THHN/THWN-2, EGC
3	3/4" EMT	(2) 10 AWG THHN/THWN-2, Cu	(1) 10 AWG THHN/THWN-2, Cu	(1) 10 AWG THHN/THWN-2, EGC
4	3/4" EMT	(2) 6 AWG THHN/THWN-2, Cu	(1) 6 AWG THHN/THWN-2, Cu	(1) 10 AWG THHN/THWN-2, EGC

PROJECT ID	AUR-87459
DATE	10/17/2023
CREATED BY	NC
SIGNATURE	

**SINGLE LINE DIAGRAM
 PV-4**

SYSTEM CHARACTERISTICS	
DC SYSTEM SIZE	6075W
INVERTER STRING VOLTAGE:Vmp	380V
MAX INVERTER SYSTEM VOLTAGE:Voc	480V
MAX SHORT CIRCUIT CURRENT	15A
OPERATING CURRENT	15.98A

OCPD CALCULATION	
ALLOWBLE BACKFEED:	
MAIN PANEL RATING	= 200A
MAIN BREAKER RATING	= 200A
LINE SIDE TAP 100% OF ALLOWABLE BACKFEED	= 200A
INVERTER OVERCURRENT PROTECTION:	
INVERTER OVERCURRENT PROTECTION	= INVERTER O/P CURRENT * CONTINUOUS LOAD (1.25)
	= 21 * 1.25
	= 26.25A
PV OVERCURRENT PROTECTION	= 30A ≥ 26.25A
PV BACKFEED	≤ 30A PV OVERCURRENT PROTECTION

CONTRACTOR INFORMATION



PALMETTO SOLAR
 ADDRESS: 997 MORRISON DRIVE,
 SUITE 200, CHARLESTON, SC 29403
 PHONE NUMBER: (855) 339-1831

CUSTOMER INFORMATION

NAME: EDUARDO CARRANZA
 ADDRESS: 94 MARY ROBERTSON
 STREET, DUNN, NC 28334
 COORDINATES: 35.300304, -78.666147
 APN: 0596946308000
 6.075kW DC / 5.000kW AC ROOF
 MOUNT PV SYSTEM

- ELECTRICAL NOTES**
- CONDUCTORS EXPOSED TO SUNLIGHT SHALL BE LISTED AS SUNLIGHT RESISTANT PER NEC 310.10(D).
 - CONDUCTORS EXPOSED TO WET LOCATIONS SHALL BE SUITABLE FOR USE IN WET LOCATIONS PER NEC 310.10(C).
 - MAXIMUM DC/AC VOLTAGE DROP SHALL BE NO MORE THAN 2%.
 - ALL CONDUCTORS SHALL BE IN CONDUIT UNLESS OTHERWISE NOTED.
 - BREAKER/FUSE SIZES PER NEC 240.
 - AC EQUIPMENT GROUNDING CONDUCTOR SIZED PER NEC 250.122.
 - AMBIENT TEMPERATURE CORRECTION FACTOR IS BASED ON NEC 310.15(B)(2)(a).
 - MAX. SYSTEM VOLTAGE COEFFICIENT IS FROM MODULE MANUFACTURER OR NEC 690.7 WHEN MANUFACTURER COEFFICIENT UNAVAILABLE.
 - CONDUCTORS ARE SIZED PER NEC TABLE 310.15(B)(16).
 - CONDUIT SHALL BE INSTALLED MINIMUM 7/8" FROM ROOF SURFACE.

WIRE SIZE CALCULATIONS

AMBIENT TEMPERATURE @ 36°C

TAG 1: (DC)	
REQUIRED CONDUCTOR AMPACITY (15 * 1.25)	= 18.75A
CORRECTED AMPACITY CALCULATION (0.91 * 1 * 40)	= 36.40A
18.75A < 36.40A (#10 AWG PV WIRE)	
TAG 2: (DC)	
REQUIRED CONDUCTOR AMPACITY (15 * 1.25)	= 18.75A
CORRECTED AMPACITY CALCULATION (0.91 * 1 * 40)	= 36.40A
18.75A < 36.40A (3/4" EMT, #10 AWG THHN/THWN-2, Cu)	
TAG 3: (AC)	
REQUIRED CONDUCTOR AMPACITY (21 * 1 * 1.25)	= 26.25A
CORRECTED AMPACITY CALCULATION (0.88 * 1 * 35)	= 30.80A
26.25A < 30.80A (3/4" EMT, #10 AWG THHN/THWN-2, Cu)	
TAG 4: (AC)	
REQUIRED CONDUCTOR AMPACITY (21 * 1 * 1.25)	= 26.25A
CORRECTED AMPACITY CALCULATION (0.88 * 1 * 65)	= 57.20A
26.25A < 57.20A (3/4" EMT, #6 AWG THHN/THWN-2, Cu)	

DC WIRE SIZING CALCULATIONS BASED ON FOLLOWING EQUATIONS

REQUIRED CONDUCTOR AMPACITY:
 $I_{sc}(A) * \# \text{ OF PARALLEL STRINGS} = \text{MAX CURRENT PER } 690.8(A)(5) * 125\%$
 $= \text{MAX CURRENT PER } 690.8(B)(1)$

CORRECTED AMPACITY CALCULATIONS:
 DERATED CONDUCTOR AMPACITY PER 690.8(B)(2) = AMPACITY * TEMPERATURE DERATE FACTOR * CONDUIT FILL DERATE
 DERATED CONDUCTOR AMPACITY CHECK : MAX CURRENT PER 690.8(B)(1) < DERATED CONDUCTOR AMPACITY

AC WIRE SIZING CALCULATIONS BASED ON FOLLOWING EQUATIONS

REQUIRED CONDUCTOR AMPACITY:
 $\text{INVERTER OUTPUT CURRENT} * \# \text{ OF INVERTERS} = \text{MAX CURRENT PER } 690.8(A)(3) * 125\%$
 $= \text{MAX CURRENT PER } 690.8(B)(1)$

CORRECTED AMPACITY CALCULATIONS:
 DERATED CONDUCTOR AMPACITY PER 690.8(B)(2) = AMPACITY * TEMPERATURE DERATE FACTOR * CONDUIT FILL DERATE
 DERATED CONDUCTOR AMPACITY CHECK : MAX CURRENT PER 690.8(B)(1) < DERATED CONDUCTOR AMPACITY

PROJECT ID	AUR-87459
DATE	10/17/2023
CREATED BY	NC
SIGNATURE	
ELECTRICAL CALCULATIONS	
PV-4.1	

WARNING

ELECTRIC SHOCK HAZARD

TERMINALS ON BOTH LINE AND LOAD SIDES MAY BE ENERGIZED IN THE OPEN POSITION

DC VOLTAGE IS ALWAYS PRESENT WHEN SOLAR MODULES ARE EXPOSED TO SUNLIGHT

LABEL LOCATION
AC DISCONNECT, POINT OF INTERCONNECTION
PER CODE: NEC 690.13

WARNING:PHOTOVOLTAIC POWER SOURCE

LABEL LOCATION
CONDUIT, INVERTER DC DISCONNECT
PER CODE: NEC 690.31(G)(3)

PHOTOVOLTAIC AC DISCONNECT

LABEL LOCATION
AC DISCONNECT, POINT OF INTERCONNECTION
PER CODE: NEC 690.13(B)

SOLAR PV SYSTEM EQUIPPED WITH RAPID SHUTDOWN

TURN RAPID SHUTDOWN SWITCH TO THE "OFF" POSITION TO SHUT DOWN PV SYSTEM AND REDUCE SHOCK HAZARD IN THE ARRAY

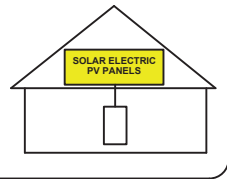

LABEL LOCATION
AC DISCONNECT, INVERTER DC DISCONNECT, POINT OF INTERCONNECTION
PER CODE: NEC 690.56(C)(1)(a)

RAPID SHUTDOWN SWITCH FOR SOLAR PV SYSTEM

LABEL LOCATION
INVERTER DC DISCONNECT
PER CODE: NEC 690.56(C)(3)

PHOTOVOLTAIC SYSTEM AC DISCONNECT SWITCH

RATED AC OPERATING CURRENT **21.00** AMPS AC
AC NOMINAL OPERATING VOLTAGE **240** VAC

LABEL LOCATION
AC DISCONNECT, POINT OF INTERCONNECTION
PER CODE: NEC 690.54

WARNING

DUAL POWER SOURCE SECOND SOURCE IS PHOTOVOLTAIC SYSTEM

LABEL LOCATION
POINT OF INTERCONNECTION
PER CODE: NEC 705.12(B)(3)

INVERTER-1

MAXIMUM SYSTEM VOLTAGE(Voc)	480	V
MAXIMUM CIRCUIT CURRENT(Isc)	15	A
MAXIMUM RATED OUTPUT CURRENT OF THE CHARGE CONTROLLER OR DC-TO-DC CONVERTER(IF INSTALLED)	15	A

LABEL LOCATION
INVERTER DC DISCONNECT
PER CODE: NEC 690.53

CAUTION: MULTIPLE SOURCES OF POWER

POWER TO THIS BUILDING IS ALSO SUPPLIED FROM THE FOLLOWING SOURCES WITH DISCONNECTS LOCATED AS SHOWN

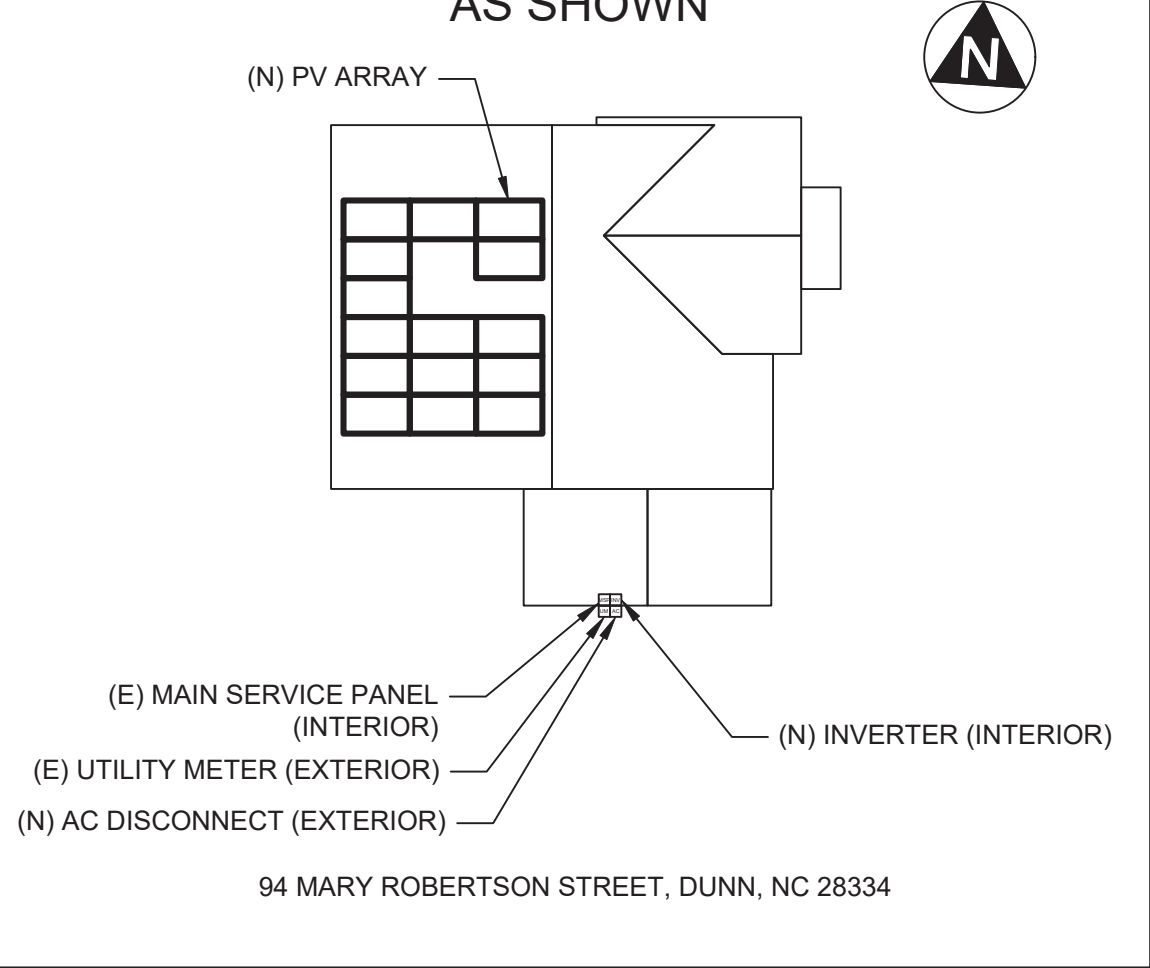

(N) PV ARRAY

(E) MAIN SERVICE PANEL (INTERIOR)

(E) UTILITY METER (EXTERIOR)

(N) AC DISCONNECT (EXTERIOR)

(N) INVERTER (INTERIOR)

94 MARY ROBERTSON STREET, DUNN, NC 28334

NOTES

1. PLACARDS SHALL MEET THE REQUIREMENTS OF ARTICLES 690 AND 705, UNLESS OTHERWISE SPECIFIED PER LOCAL AHJ REQUIREMENTS.
2. PLACARDS SHALL MEET THE REQUIREMENTS OF SECTION 110.21(B) AS REQUIRED AND SHALL COMPLY WITH ANSI Z535.4-2011, PRODUCT SAFETY SIGNS AND LABELS.
3. PLACARDS SHALL BE PERMANENTLY AFFIXED TO THE EQUIPMENT OR WIRING METHOD.
4. PLACARDS SHALL BE OF SUFFICIENT DURABILITY TO WITHSTAND THE ENVIRONMENT INVOLVED AND SHALL BE HANDWRITTEN.
5. PLACARDS SHALL NOT COVER EXISTING MANUFACTURER LABELS.
6. WARNING SIGNAGE TEXT SHALL BE MINIMUM 3/8" TALL.

LABEL LOCATION
SERVICE PANEL
PER CODE: NEC 705.10

CONTRACTOR INFORMATION



PALMETTO SOLAR

ADDRESS: 997 MORRISON DRIVE, SUITE 200, CHARLESTON, SC 29403

PHONE NUMBER: (855) 339-1831

CUSTOMER INFORMATION

NAME: EDUARDO CARRANZA

ADDRESS: 94 MARY ROBERTSON STREET, DUNN, NC 28334

COORDINATES: 35.300304, -78.666147

APN: 0596946308000

6.075kW DC / 5.000kW AC ROOF MOUNT PV SYSTEM

PROJECT ID	AUR-87459
DATE	10/17/2023
CREATED BY	NC
SIGNATURE	
PLACARDS PV-5	

Q.PEAK DUO BLK ML-G10+ SERIES



385-410 Wp | 132 Cells
20.9% Maximum Module Efficiency

MODEL **Q.PEAK DUO BLK ML-G10+**



6 busbar cell technology

12 busbar cell technology



Breaking the 20% efficiency barrier

Q.ANTUM DUO Z Technology with zero gap cell layout boosts module efficiency up to 20.9%.



A reliable investment

Inclusive 25-year product warranty and 25-year linear performance warranty¹.



Enduring high performance

Long-term yield security with Anti LeTID Technology, Anti PID Technology² and Hot-Spot Protect.



Extreme weather rating

High-tech aluminium alloy frame, certified for high snow (5400 Pa) and wind loads (4000 Pa).



Innovative all-weather technology

Optimal yields, whatever the weather with excellent low-light and temperature behaviour.



The most thorough testing programme in the industry

Qcells is the first solar module manufacturer to pass the most comprehensive quality programme in the industry. The new "Quality Controlled PV" of the independent certification institute TÜV Rheinland.

¹ See data sheet on rear for further information.
² APT test conditions according to IEC/TS 62804-12015, method A (-1500V, 96h)

The ideal solution for:
Rooftop arrays on residential buildings



Q.PEAK DUO BLK ML-G10+ SERIES

Mechanical Specification

Format	74.0 in × 41.1 in × 1.26 in (including frame) (1879 mm × 1045 mm × 32 mm)
Weight	48.5 lbs (22.0 kg)
Front Cover	0.13 in (3.2 mm) thermally pre-stressed glass with anti-reflection technology
Back Cover	Composite film
Frame	Black anodised aluminium
Cell	6 × 22 monocrystalline Q.ANTUM solar half cells
Junction box	2.09-3.98 in × 1.26-2.36 in × 0.59-0.71 in (53-101 mm × 32-60 mm × 15-18 mm), IP67, with bypass diodes
Cable	4mm ² Solar cable; (+) ≥ 49.2 in (1250 mm), (-) ≥ 49.2 in (1250 mm)
Connector	Stäubli MC4; IP68

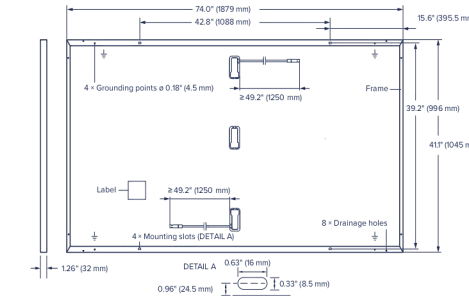

Electrical Characteristics

POWER CLASS	385	390	395	400	405	410	
MINIMUM PERFORMANCE AT STANDARD TEST CONDITIONS, STC ¹ (POWER TOLERANCE +5W/-0W)							
Power at MPP ¹	P _{MPP} [W]	385	390	395	400	405	410
Short Circuit Current ¹	I _{SC} [A]	11.04	11.07	11.10	11.14	11.17	11.20
Open Circuit Voltage ¹	V _{OC} [V]	45.19	45.23	45.27	45.30	45.34	45.37
Current at MPP	I _{MPP} [A]	10.59	10.65	10.71	10.77	10.83	10.89
Voltage at MPP	V _{MPP} [V]	36.36	36.62	36.88	37.13	37.39	37.64
Efficiency ¹	η [%]	≥ 19.6	≥ 19.9	≥ 20.1	≥ 20.4	≥ 20.6	≥ 20.9

MINIMUM PERFORMANCE AT NORMAL OPERATING CONDITIONS, NMOT²

Power at MPP	P _{MPP} [W]	288.8	292.6	296.3	300.1	303.8	307.6
Short Circuit Current	I _{SC} [A]	8.90	8.92	8.95	8.97	9.00	9.03
Open Circuit Voltage	V _{OC} [V]	42.62	42.65	42.69	42.72	42.76	42.79
Current at MPP	I _{MPP} [A]	8.35	8.41	8.46	8.51	8.57	8.62
Voltage at MPP	V _{MPP} [V]	34.59	34.81	35.03	35.25	35.46	35.68

¹ Measurement tolerances P_{MPP} ± 3%; I_{SC}, V_{OC} ± 5% at STC: 1000 W/m², 25 ± 2°C, AM 1.5 according to IEC 60904-3 • ² 800 W/m², NMOT, spectrum AM 1.5

Qcells PERFORMANCE WARRANTY

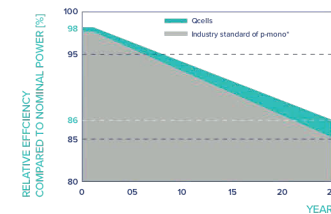

At least 98% of nominal power during first year. Thereafter max. 0.5% degradation per year. At least 93.5% of nominal power up to 10 years. At least 86% of nominal power up to 25 years.

All data within measurement tolerances. Full warranties in accordance with the warranty terms of the Qcells sales organisation of your respective country.

¹ Standard terms of guarantee for the 5 PV companies with the highest production capacity in 2021 (February 2021)

PERFORMANCE AT LOW IRRADIANCE

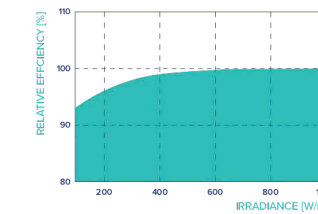

Typical module performance under low irradiance conditions in comparison to STC conditions (25°C, 1000 W/m²).

TEMPERATURE COEFFICIENTS

Temperature Coefficient of I _{SC}	α [%/K]	+0.04	Temperature Coefficient of V _{OC}	β [%/K]	-0.27
Temperature Coefficient of P _{MPP}	γ [%/K]	-0.34	Nominal Module Operating Temperature	NMOT [°F]	109 ± 5.4 (43 ± 3°C)

Properties for System Design

Maximum System Voltage	V _{sys} [V]	1000 (IEC)/1000 (UL)	PV module classification	Class II
Maximum Series Fuse Rating	[A DC]	20	Fire Rating based on ANSI/UL 61730	TYPE 2
Max. Design Load, Push/Pull ³	[lbs/ft ²]	75 (3600 Pa)/55 (2660 Pa)	Permitted Module Temperature on Continuous Duty	-40°F up to +185°F (-40°C up to +85°C)
Max. Test Load, Push/Pull ³	[lbs/ft ²]	113 (5400 Pa)/84 (4000 Pa)		

³ See Installation Manual

Qualifications and Certificates

UL 61730, CE-compliant, Quality Controlled PV - TÜV Rheinland, IEC 61215:2016, IEC 61730:2016, U.S. Patent No. 9,893,215 (solar cells),



Qcells pursues minimizing paper output in consideration of the global environment.

Note: Installation instructions must be followed. Contact our technical service for further information on approved installation of this product.
Honwha Q CELLS America Inc. 400 Spectrum Center Drive, Suite 1400, Irvine, CA 92618, USA | TEL: +1 949 748 59 96 | EMAIL: hqc-inquiry@qcells.com | WEB: www.qcells.com



CONTRACTOR INFORMATION



PALMETTO SOLAR
ADDRESS: 997 MORRISON DRIVE,
SUITE 200, CHARLESTON, SC 29403
PHONE NUMBER: (855) 339-1831

CUSTOMER INFORMATION

NAME: EDUARDO CARRANZA
ADDRESS: 94 MARY ROBERTSON
STREET, DUNN, NC 28334
COORDINATES: 35.300304, -78.666147
APN: 0596946308000

6.075kW DC / 5.000kW AC ROOF
MOUNT PV SYSTEM

PROJECT ID: AUR-87459

DATE: 10/17/2023

CREATED BY: NC

SIGNATURE

MODULE SPEC SHEET
SS

Specifications subject to technical changes © Qcells Q.PEAK DUO BLK ML-G10+ series_385-410_2023-01_Rev03_NA

SolarEdge Home Wave Inverter For North America

SE3800H-US / SE5000H-US / SE6000H-US /
SE7600H-US / SE10000H-US / SE11400H-US

12-25
YEAR
WARRANTY



INVERTERS

Optimized installation with HD-Wave technology

- Specifically designed to work with power optimizers
- Record-breaking 99% weighted efficiency
- Quick and easy inverter commissioning directly from a smartphone using SolarEdge SetApp
- Fixed voltage inverter for longer strings
- Integrated arc fault protection and rapid shutdown for NEC 2014-2023 per articles 690.11 and 690.12
- UL1741 SA certified, for CPUC Rule 21 grid compliance
- Small, lightweight, and easy to install both outdoors or indoors
- Built-in module-level monitoring
- Optional: Faster installations with built-in consumption metering (1% accuracy) and production revenue grade metering (0.5% accuracy, ANSI C12.20)

solaredge.com



/ SolarEdge Home Wave Inverter

For North America

SE3800H-US / SE5000H-US / SE6000H-US /
SE7600H-US / SE10000H-US / SE11400H-US

Applicable to inverters with part number	SEXXXXH-XXXXBXX4					SE11400H-XXXXBXX5	Units
	SE3800H-US	SE5000H-US	SE6000H-US	SE7600H-US	SE10000H-US	SE11400H-US	
OUTPUT							
Rated AC Power Output	3800 @ 240V 3300 @ 208V	5000	6000 @ 240V 5000 @ 208V	7600	10000	11400 @ 240V 10000 @ 208V	VA
Maximum AC Power Output	3800 @ 240V 3300 @ 208V	5000	6000 @ 240V 5000 @ 208V	7600	10000	11400 @ 240V 10000 @ 208V	VA
AC Output Voltage Min.-Nom.-Max. (211 - 240 - 264)	✓	✓	✓	✓	✓	✓	Vac
AC Output Voltage Min.-Nom.-Max. (183 - 208 - 229)	✓	-	✓	-	-	✓	Vac
AC Frequency (Nominal)	59.3 - 60 - 60.5 ⁽¹⁾						Hz
Maximum Continuous Output Current @240V	16	21	25	32	42	47.5	A
Maximum Continuous Output Current @208V	16	-	24	-	-	48.5	A
Power Factor	1, Adjustable - 0.85 to 0.85						
GFDI Threshold	1						A
Utility Monitoring, Islanding Protection, Country Configurable Thresholds	Yes						
INPUT							
Maximum DC Power @240V	5900	7750	9300	11800	15500	17650	W
Maximum DC Power @208V	5100	-	7750	-	-	15500	W
Transformer-less, Ungrounded	Yes						
Maximum Input Voltage	480						Vdc
Nominal DC Input Voltage	380						Vdc
Maximum Input Current @240V ⁽²⁾	10.5	13.5	16.5	20	27	30.5	Adc
Maximum Input Current @208V ⁽²⁾	9	-	13.5	-	-	27	Adc
Max. Input Short Circuit Current	45						Adc
Reverse-Polarity Protection	Yes						
Ground-Fault Isolation Detection	600k Sensitivity						
Maximum Inverter Efficiency	99.2						%
CEC Weighted Efficiency	99					99 @ 240V 98.5 @ 208V	%
Nighttime Power Consumption	< 2.5						W

(1) For other regional settings please contact SolarEdge support.
(2) A higher current source may be used; the inverter will limit its input current to the values stated.

CONTRACTOR INFORMATION



PALMETTO SOLAR
ADDRESS: 997 MORRISON DRIVE,
SUITE 200, CHARLESTON, SC 29403
PHONE NUMBER: (855) 339-1831

CUSTOMER INFORMATION

NAME: EDUARDO CARRANZA
ADDRESS: 94 MARY ROBERTSON
STREET, DUNN, NC 28334
COORDINATES: 35.300304, -78.666147
APN: 0596946308000
6.075kW DC / 5.000kW AC ROOF
MOUNT PV SYSTEM

PROJECT ID AUR-87459

DATE 10/17/2023

CREATED BY NC

SIGNATURE

INVERTER SPEC SHEET
SS

/ SolarEdge Home Wave Inverter

For North America

SE3800H-US / SE5000H-US / SE6000H-US/
SE7600H-US / SE10000H-US / SE11400H-US

Applicable to inverters with part number	SEXXXXH-XXXXBXX4				SE11400H-XXXXBXX5	
	SE3800H-US	SE5000H-US	SE6000H-US	SE7600H-US	SE10000H-US	SE11400H-US
ADDITIONAL FEATURES						
Supported Communication Interfaces	RS485, Ethernet, ZigBee (optional), wireless SolarEdge Home Network (optional) ⁽³⁾ , Wi-Fi (optional), Cellular (optional)					
Revenue Grade Metering, ANSI C12.20	Optional ⁽⁴⁾					
Consumption Metering	Optional ⁽⁴⁾					
Inverter Commissioning	With the SetApp mobile application using Built-in Wi-Fi Access Point for Local Connection					
Rapid Shutdown - NEC 2014-2023 per articles 690.11 and 690.12	Automatic Rapid Shutdown upon AC Grid Disconnect					
STANDARD COMPLIANCE						
Safety	UL1741, UL1741 SA, UL1741 SB, UL1699B, CSA C22.2, Canadian AFCI according to T.I.L. M-07					
Grid Connection Standards	IEEE1547-2018, Rule 21, Rule 14 (HI), CSA C22.3 No. 9					
Emissions	FCC Part 15 Class B					
INSTALLATION SPECIFICATIONS						
AC Output Conduit Size / AWG Range	1" Maximum / 14 - 6 AWG			1" Maximum / 14 - 4 AWG		
DC Input Conduit Size / # of Strings / AWG Range	1" Maximum / 1 - 2 strings / 14 - 6 AWG			1" Maximum / 1 - 3 strings / 14 - 6 AWG		
Dimensions with Safety Switch (H x W x D)	17.7 x 14.6 x 6.8 / 450 x 370 x 174			21.06 x 14.6 x 7.3 / 535 x 370 x 185	21.06 x 14.6 x 8.2 / 535 x 370 x 208 ⁽⁵⁾	in / mm
Weight with Safety Switch	22 / 10	25.1 / 11.4	26.2 / 11.9	38.8 / 17.6	44.9 / 20.4 ⁽⁵⁾	lb / kg
Noise	< 25			< 50		dBA
Cooling	Natural Convection					
Operating Temperature Range	-40 to +140 / -40 to +60 ⁽⁶⁾					
Protection Rating	NEMA 4X (Inverter with Safety Switch)					

(3) For more information, refer to the [SolarEdge Home Network](#) datasheet

(4) Inverter with Revenue Grade Production and Consumption Meter P/N: SExxxxH-US000BEI4. For consumption metering, current transformers should be ordered separately: SEACT0750-200NA-20 or SEACT0750-400NA-20, 20 units per box.

(5) SE11400H-USxxxxBXX5 is the updated PN, though SE11400H-USxxxxBXX4 will still be available. All specifications are similar for both models, EXCLUDING the weight and dimensions [HxWxD]. The weight and dimensions of SE11400H-USxxxxBXX4 are 17.6 [kg] and 21.06-14.6-7.3 / 535-370-185 [in/mm], accordingly.

(6) Full power up to at least 50°C / 122°F; for power de-rating information refer to the [Temperature De-rating Technical Note for North America](#).

How to Enable Consumption Monitoring

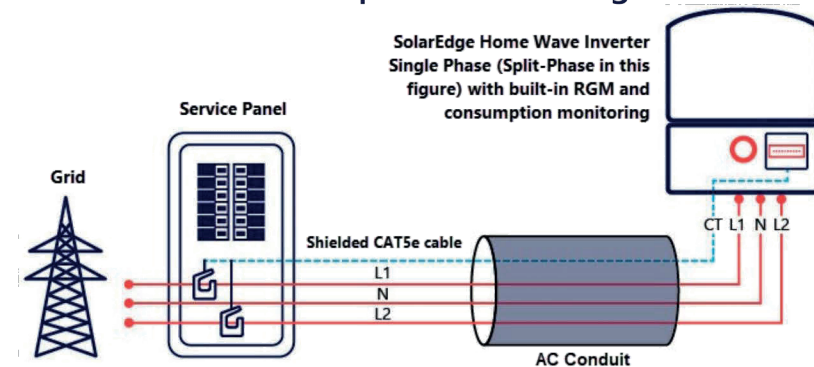

By simply wiring current transformers through the inverter's existing AC conduits and connecting them to the service panel, homeowners will gain full insight into their household energy usage helping them to avoid high electricity bills.

© SolarEdge Technologies, Ltd. All rights reserved. SOLAREEDGE, the SolarEdge logo, OPTIMIZED BY SOLAREEDGE are trademarks or registered trademarks of SolarEdge Technologies, Inc. All other trademarks mentioned herein are trademarks of their respective owners. Date: June 19, 2023 DS-000153-NAM. Subject to change without notice.



CONTRACTOR INFORMATION



PALMETTO SOLAR

ADDRESS: 997 MORRISON DRIVE,
SUITE 200, CHARLESTON, SC 29403

PHONE NUMBER: (855) 339-1831

CUSTOMER INFORMATION

NAME: EDUARDO CARRANZA

ADDRESS: 94 MARY ROBERTSON
STREET, DUNN, NC 28334

COORDINATES: 35.300304, -78.666147

APN: 0596946308000

6.075kW DC / 5.000kW AC ROOF
MOUNT PV SYSTEM

PROJECT ID AUR-87459

DATE 10/17/2023

CREATED BY NC

SIGNATURE

INVERTER SPEC SHEET
SS

Power Optimizer For Residential Installations

S440 / S500 / S500B / S650B



POWER OPTIMIZER

Enabling PV power optimization at the module level

- Specifically designed to work with SolarEdge residential inverters
- Mitigates all types of module mismatch loss, from manufacturing tolerance to partial shading
- Detects abnormal PV connector behavior, preventing potential safety issues*
- Faster installations with simplified cable management and easy assembly using a single bolt
- Module-level voltage shutdown for installer and firefighter safety
- Flexible system design for maximum space utilization
- Superior efficiency (99.5%)
- Compatible with bifacial PV modules

* Functionality subject to inverter model and firmware version

solaredge.com



Power Optimizer For Residential Installations

S440 / S500 / S500B / S650B

	S440	S500	S500B	S650B	UNIT
INPUT					
Rated Input DC Power ⁽¹⁾	440	500	500	650	W
Absolute Maximum Input Voltage (Voc)	60	125	125	85	Vdc
MPPT Operating Range	8 – 60	12.5 – 105	12.5 – 105	12.5 – 85	Vdc
Maximum Short Circuit Current (Isc) of Connected PV Module	14.5	15	15	15	Adc
Maximum Efficiency		99.5	99.5	99.5	%
Weighted Efficiency		98.6	98.6	98.6	%
Overtoltage Category		II	II	II	
OUTPUT DURING OPERATION					
Maximum Output Current		15	15	15	Adc
Maximum Output Voltage	60	80	80	80	Vdc
OUTPUT DURING STANDBY (POWER OPTIMIZER DISCONNECTED FROM INVERTER OR INVERTER OFF)					
Safety Output Voltage per Power Optimizer		1 ± 0.1	1 ± 0.1	1 ± 0.1	Vdc
STANDARD COMPLIANCE⁽²⁾					
EMC	FCC Part 15 Class B, IEC61000-6-2, IEC61000-6-3, CISPR11, EN-55011				
Safety	IEC62109-1 (class II safety), UL1741				
Material	UL94 V-0, UV Resistant				
RoHS	Yes				
Fire Safety	VDE-AR-E 2100-712:2018-12				
INSTALLATION SPECIFICATIONS					
Maximum Allowed System Voltage		1000	1000	1000	Vdc
Dimensions (W x L x H)	129 x 155 x 30	129 x 165 x 45	129 x 165 x 45	129 x 165 x 45	mm
Weight	720	790	790	790	gr
Input Connector		MC4 ⁽³⁾	MC4 ⁽³⁾	MC4 ⁽³⁾	
Input Wire Length		0.1	0.1	0.1	m
Output Connector		MC4	MC4	MC4	
Output Wire Length		(+) 2.3, (-) 0.10	(+) 2.3, (-) 0.10	(+) 2.3, (-) 0.10	m
Operating Temperature Range ⁽⁴⁾		-40 to +85	-40 to +85	-40 to +85	°C
Protection Rating		IP68	IP68	IP68	
Relative Humidity		0 – 100	0 – 100	0 – 100	%

(1) Rated power of the module at STC will not exceed the Power Optimizer Rated Input DC Power. Modules with up to +5% power tolerance are allowed.
 (2) For details about CE compliance, see [Declaration of Conformity – CE](#).
 (3) For other connector types please contact SolarEdge.
 (4) Power de-rating is applied for ambient temperatures above +85°C for S440 and S500, and for ambient temperatures above +75°C for S500B. Refer to the [Power Optimizers Temperature De-Rating Technical Note](#) for details.

PV System Design Using a SolarEdge Inverter ⁽⁵⁾	SolarEdge Home Wave Inverter Single Phase	SolarEdge Home Short String Inverter Three Phase	Three Phase for 230/400V Grid	Three Phase for 277/480V Grid	
Minimum String Length (Power Optimizers)	S440, S500 S500B, S650B	8 6	9 8	16 14	
Maximum String Length (Power Optimizers)		25	20	50	
Maximum Continuous Power per String		5700	5625	11,250	12,750 W
Maximum Allowed Connected Power per String ⁽⁶⁾ (In multiple string designs, the maximum is permitted only when the difference in connected power between strings is 2,000W or less)		6800 ⁽⁷⁾	See ⁽⁶⁾	13,500	15,000 W
Parallel Strings of Different Lengths or Orientations			Yes		

(5) It is not allowed to mix S-series and P-series Power Optimizers in new installations in the same string.
 (6) If the inverter's rated AC power ≤ maximum continuous power per string, then the maximum connected power per string will be able to reach up to the inverter's maximum input DC power. Refer to the [Single String Design Guidelines](#) application note.
 (7) For inverters with a rated AC power ≥ 7600W that are connected to at least two strings.

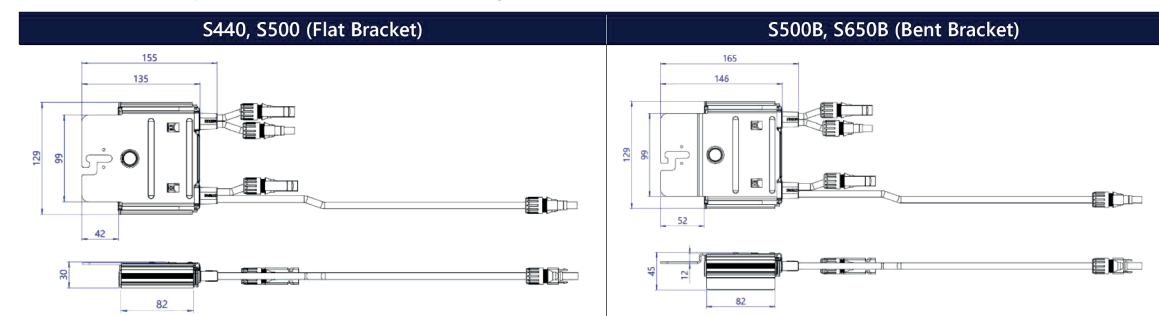

© SolarEdge Technologies, Ltd. All rights reserved. SOLAREEDGE, the SolarEdge logo, OPTIMIZED BY SOLAREEDGE are trademarks or registered trademarks of SolarEdge Technologies, Inc. All other trademarks mentioned herein are trademarks of their respective owners. Date: August 14, 2023 DS-000091-ENG. Subject to change without notice.



CONTRACTOR INFORMATION



PALMETTO SOLAR
 ADDRESS: 997 MORRISON DRIVE,
 SUITE 200, CHARLESTON, SC 29403
 PHONE NUMBER: (855) 339-1831

CUSTOMER INFORMATION

NAME: EDUARDO CARRANZA
 ADDRESS: 94 MARY ROBERTSON
 STREET, DUNN, NC 28334
 COORDINATES: 35.300304, -78.666147
 APN: 0596946308000
 6.075kW DC / 5.000kW AC ROOF
 MOUNT PV SYSTEM

PROJECT ID	AUR-87459
DATE	10/17/2023
CREATED BY	NC
SIGNATURE	

OPTIMIZER SPEC SHEET
 SS



QuickMount™ L-Mount®

Roof Protection without Compromise

The L-Mount® attachment, featuring an open-slotted L-Foot, is designed for cost-effective, single-bolt installation onto existing composition (asphalt) shingle roofs. The patented Elevated Water Seal Technology® has been integrated into the open-slotted L-Foot and flashing for fast installation, to provide maximum waterproofing.

To maximize versatility, the mount is available with a lag bolt or structural screw option for the strength you depend on. Both hardware options come with an installed EPDM bonded washer to seal and prevent water entry.

L-Mount features a 9x12" aluminum flashing with alignment guides and rounded corners, to easily slide under shingles and speed up installation on the roof. The kit is available in both mill and black finishes.

This component is part of the QuickMount™ product line.

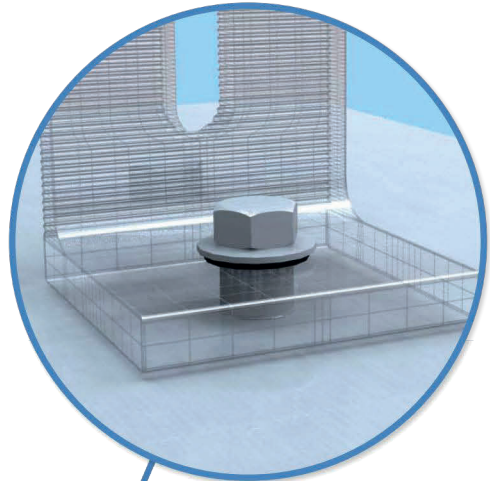

Elevated Water Seal Technology®
This proprietary flashing design cleverly places the roof penetration seal onto an aluminum flute fused into the flashing, above the bolt hole. The secondary EPDM rubber seal keeps water out—raised above the path of rain water and out of harm's way.

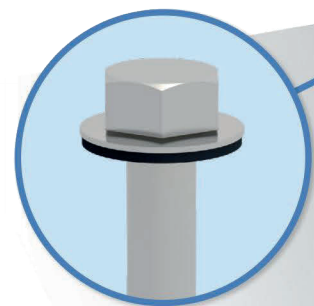

Pre-Installed Sealing Washer
Hardware options include a lag bolt or structural screw. The EPDM washer arrives already attached.

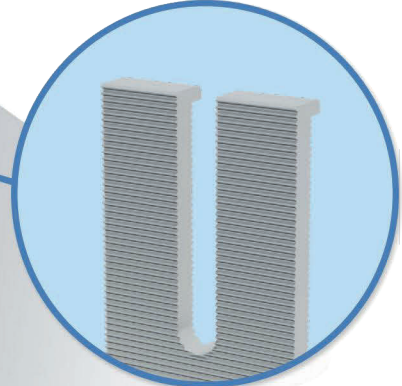

Open-Slotted L-Foot
The redesigned L-Foot can rotate 360 degrees for optimal adjustability and positioning of the rail, while the open slot allows the rail hardware to quickly drop-in and be compatible with any side-mounted racking on the market.



25-Year Warranty
Product guaranteed free of impairing defects.



L-Mount® Installation Instructions

Installation Tools Required: tape measure, roofing bar, chalk line, stud finder, caulking gun, sealant compatible with roofing materials, drill with 7/32" or 1/8" bit, drill or impact gun with 1/2" socket.

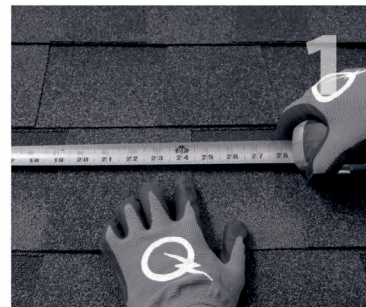

1. Locate, choose, and mark centers of rafters to be mounted. Select the courses of shingles where mounts will be placed.



2. Carefully lift composition roof shingle with roofing bar, just above placement of mount. Remove nails as required and backfill holes with approved sealant. See "Proper Flashing Placement" on next page.



3. Insert flashing between 1st and 2nd course. Slide up so top edge of flashing is at least 3/4" higher than the butt-edge of the 3rd course and lower flashing edge is above the butt-edge of 1st course. Mark center for drilling.

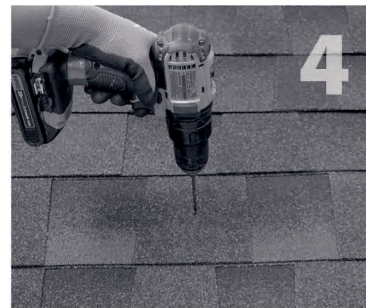

4. If attaching with lag bolt use a 7/32" bit (Lag). Use a 1/8" bit (ST) for attaching with the structural screw. Drill pilot hole into roof and rafter, taking care to drill square to the roof. Do not use mount as a drill guide. Drill a 2" deep hole into rafter.



5. Clean off any sawdust, and fill hole with sealant compatible with roofing materials.



6. Place L-foot onto elevated flute and rotate L-foot to desired orientation.

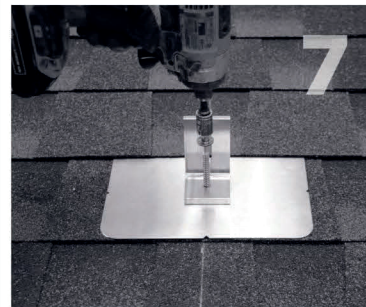

7. Prepare lag bolt or structural screw with sealing washer. Using a 1/2-inch socket on an impact gun, drive prepared lag bolt through L-foot until L-foot can no longer easily rotate. **DO NOT over-torque.** NOTE: Structural screw can be driven with T-30 hex head bit.



8. You are now ready for the rack of your choice. Follow all the directions of the rack manufacturer as well as the module manufacturer. NOTE: Make sure top of L-Foot makes solid contact with racking.

All roofing manufacturers' written instructions must also be followed by anyone modifying a roof system. Consult the roof manufacturer's specs and instructions prior to working on the roof.



PALMETTO SOLAR
ADDRESS: 997 MORRISON DRIVE,
SUITE 200, CHARLESTON, SC 29403
PHONE NUMBER: (855) 339-1831

CUSTOMER INFORMATION

NAME: EDUARDO CARRANZA
ADDRESS: 94 MARY ROBERTSON
STREET, DUNN, NC 28334

COORDINATES: 35.300304, -78.666147

APN: 0596946308000

6.075kW DC / 5.000kW AC ROOF
MOUNT PV SYSTEM

PROJECT ID	AUR-87459
DATE	10/17/2023
CREATED BY	NC
SIGNATURE	

MOUNT SPEC SHEET
SS

QuickMount®

L-Mount®

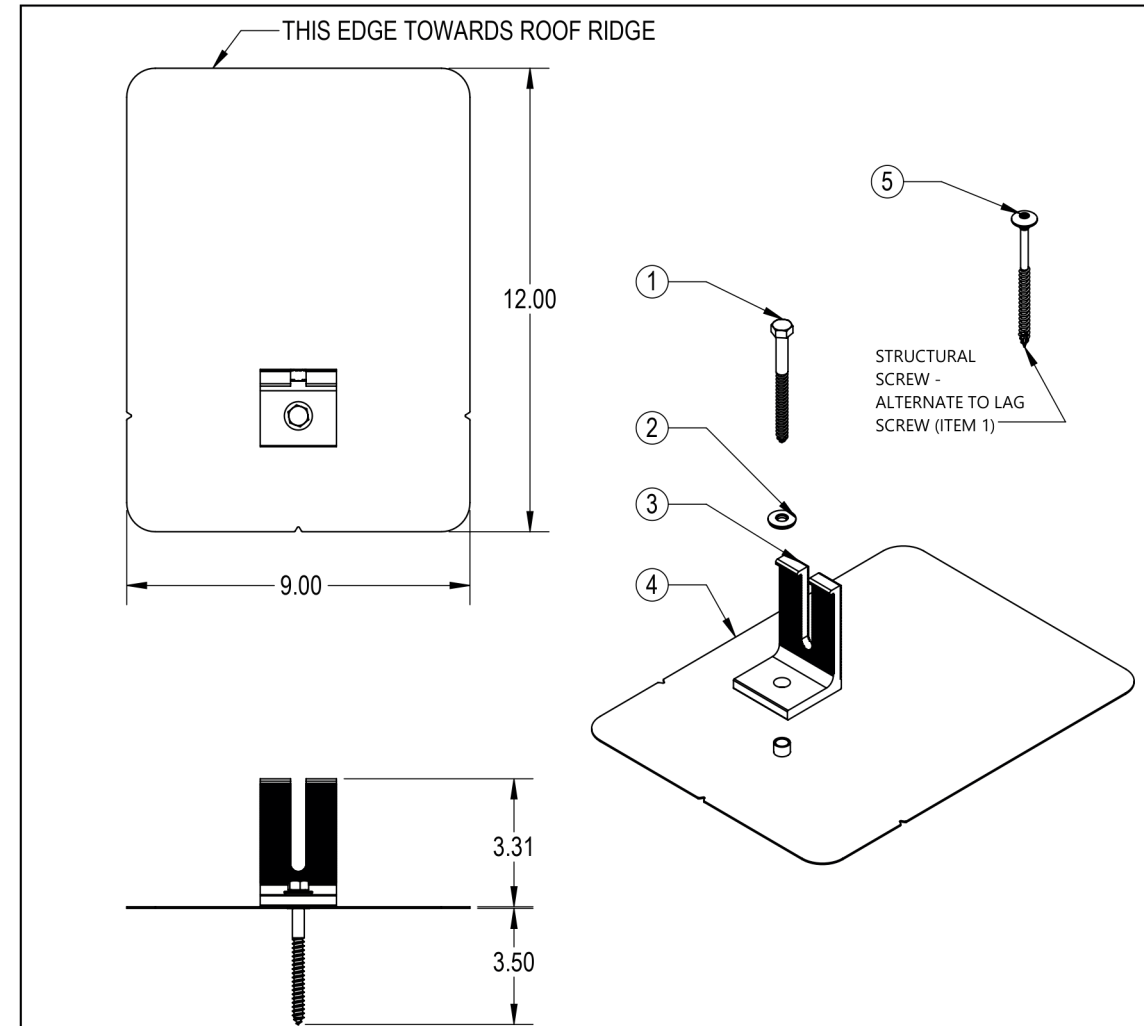

ITEM NO	DESCRIPTION
1	LAG SCREW, HEX HEAD 5/16"X4", 1/2" HEAD
2	WASHER, SEALING, EPDM BONDED SS
3	L-FOOT, 2"X3.3"
4	FLAHING, ROUNDED CORNERS
5	STRUCTURAL SCREW, T-30 HEX WASHER HEAD, 5/16"x4.5"

L-MOUNT®

SIZE **A** DO NOT SCALE DRAWING

WEIGHT: 0.7565 lbs SHEET 1 OF 1

© 2022 QuickMount All rights reserved. Visit www.Ironridge.com or call 1-800-227-9523 for more information.

L-Mount MAN Rev 1.12

CONTRACTOR INFORMATION



PALMETTO SOLAR
 ADDRESS: 997 MORRISON DRIVE,
 SUITE 200, CHARLESTON, SC 29403
 PHONE NUMBER: (855) 339-1831

CUSTOMER INFORMATION

NAME: EDUARDO CARRANZA
 ADDRESS: 94 MARY ROBERTSON
 STREET, DUNN, NC 28334
 COORDINATES: 35.300304, -78.666147
 APN: 0596946308000
 6.075kW DC / 5.000kW AC ROOF
 MOUNT PV SYSTEM

PROJECT ID AUR-87459

DATE 10/17/2023

CREATED BY NC

SIGNATURE

MOUNT SPEC SHEET
 SS



XR Rail® Family

Solar Is Not Always Sunny

Over their lifetime, solar panels experience countless extreme weather events. Not just the worst storms in years, but the worst storms in 40 years. High winds capable of ripping panels from a roof, and snowfalls weighing enough to buckle a panel frame.

XR Rails® are the structural backbone preventing these results. They resist uplift, protect against buckling and safely and efficiently transfer loads into the building structure. Their superior spanning capability requires fewer roof penetrations, reducing the number of roof penetrations and the amount of installation time.

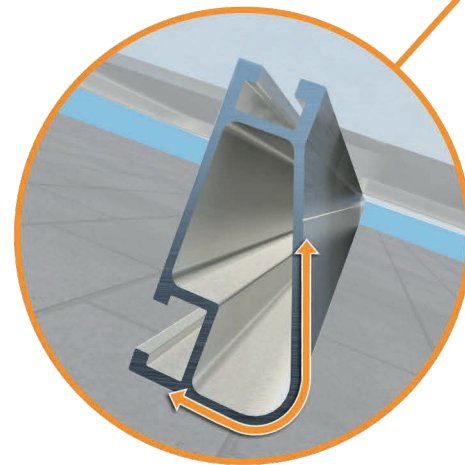
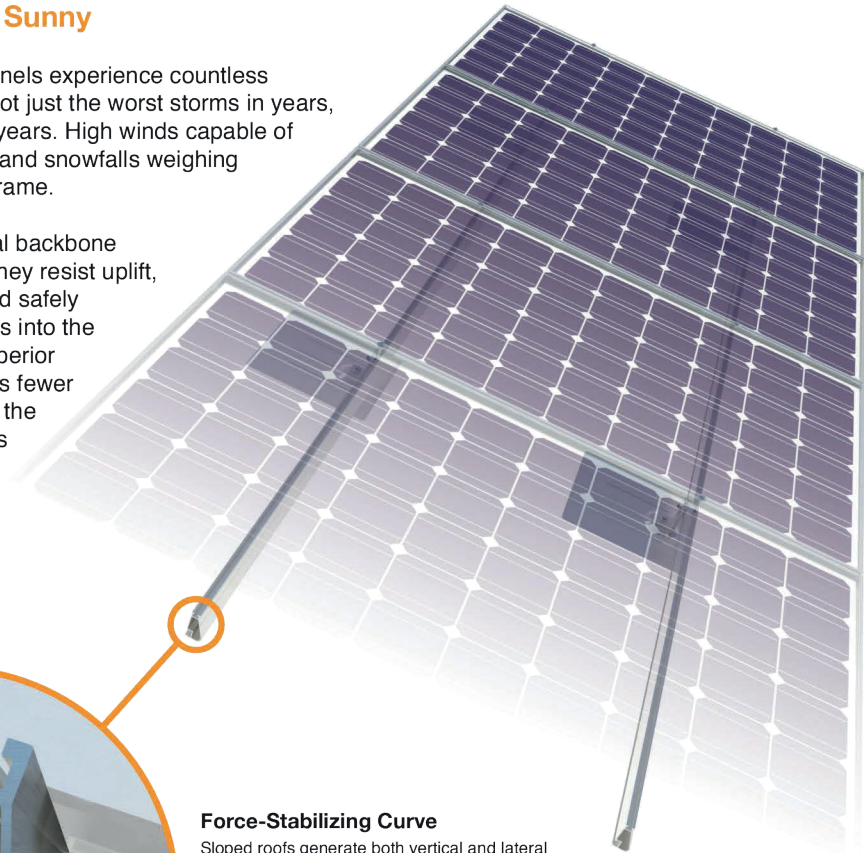

Force-Stabilizing Curve

Sloped roofs generate both vertical and lateral forces on mounting rails which can cause them to bend and twist. The curved shape of XR Rails® is specially designed to increase strength in both directions while resisting the twisting. This unique feature ensures greater security during extreme weather and a longer system lifetime.

Compatible with Flat & Pitched Roofs



XR Rails® are compatible with FlashFoot® and other pitched roof attachments.



IronRidge® offers a range of tilt leg options for flat roof mounting applications.

Corrosion-Resistant Materials

All XR Rails® are made of 6000-series aluminum alloy, then protected with an anodized finish. Anodizing prevents surface and structural corrosion, while also providing a more attractive appearance.



XR Rail® Family

The XR Rail® Family offers the strength of a curved rail in three targeted sizes. Each size supports specific design loads, while minimizing material costs. Depending on your location, there is an XR Rail® to match.

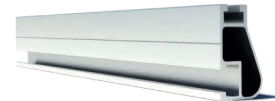

XR10

XR10 is a sleek, low-profile mounting rail, designed for regions with light or no snow. It achieves spans up to 6 feet, while remaining light and economical.

- 6' spanning capability
- Moderate load capability
- Clear & black anodized finish
- Internal splices available

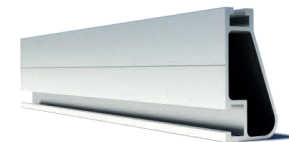

XR100

XR100 is the ultimate residential mounting rail. It supports a range of wind and snow conditions, while also maximizing spans up to 10 feet.

- 10' spanning capability
- Heavy load capability
- Clear & black anodized finish
- Internal splices available



XR1000

XR1000 is a heavyweight among solar mounting rails. It's built to handle extreme climates and spans up to 12 feet for commercial applications.

- 12' spanning capability
- Extreme load capability
- Clear anodized finish
- Internal splices available

Rail Selection

The table below was prepared in compliance with applicable engineering codes and standards.* Values are based on the following criteria: ASCE 7-16, Gable Roof Flush Mount, Roof Zones 1 & 2e, Exposure B, Roof Slope of 8 to 20 degrees and Mean Building Height of 30 ft. Visit IronRidge.com for detailed certification letters.

Load		Rail Span					
Snow (PSF)	Wind (MPH)	4'	5' 4"	6'	8'	10'	12'
None	90						
	120						
	140	XR10		XR100		XR1000	
	160						
20	90						
	120						
	140						
30	90						
	160						
40	90						
	160						
80	160						
	160						
120	160						
	160						

*Table is meant to be a simplified span chart for conveying general rail capabilities. Use approved certification letters for actual design guidance.



PALMETTO SOLAR

ADDRESS: 997 MORRISON DRIVE, SUITE 200, CHARLESTON, SC 29403

PHONE NUMBER: (855) 339-1831

CUSTOMER INFORMATION

NAME: EDUARDO CARRANZA

ADDRESS: 94 MARY ROBERTSON STREET, DUNN, NC 28334

COORDINATES: 35.300304, -78.666147

APN: 0596946308000

6.075kW DC / 5.000kW AC ROOF MOUNT PV SYSTEM

PROJECT ID AUR-87459

DATE 10/17/2023

CREATED BY NC

SIGNATURE

RAIL SPEC SHEET
SS



UFO® Family of Components

Tech Brief

Simplified Grounding for Every Application

The UFO® family of components eliminates the need for separate grounding hardware by bonding solar modules directly to IronRidge® XR Rails®. All system types that feature the UFO® family—Flush Mount®, Tilt Mount® and Ground Mount®—are fully listed to the [UL 2703](#) standard.

UFO® hardware forms secure electrical bonds with both the module and the rail, resulting in many parallel grounding paths throughout the system. This leads to safer and more reliable installations.

Only for installation and use with IronRidge products in accord with written instructions. See [IronRidge.com/UFO](#)

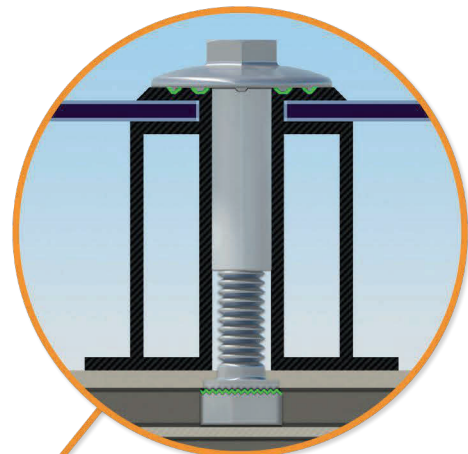

Universal Fastening Object (UFO®)
The UFO® securely bonds solar modules to XR Rails®. It comes assembled and lubricated, and can fit a wide range of module heights.

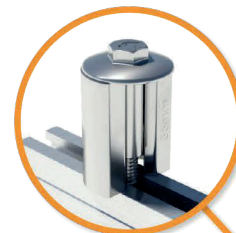

Stopper Sleeve
The Stopper Sleeve snaps onto the UFO®, converting it into a bonded end clamp.



BOSS® Splice
Bonded Structural Splice connects rails with built-in bonding teeth. No tools or hardware needed.

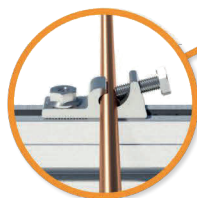

Grounding Lug
A single Grounding Lug connects an entire row of PV modules to the grounding conductor.



Bonded Attachments
The bonding bolt attaches and bonds the L-foot® to the rail. It is installed with the same socket as the rest of the system.

System Diagram

Tech Brief

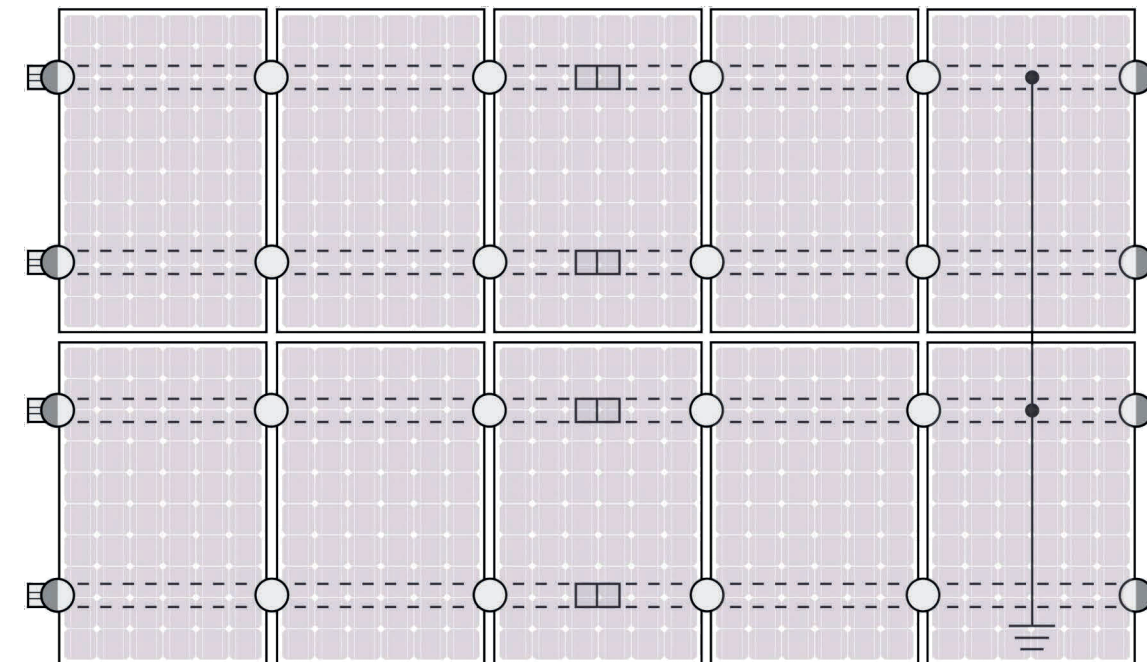

○ UFO ◐ Stopper Sleeve ● Grounding Lug ◻ BOSS™ Splice ≡ Ground Wire

⚠ Approved Enphase microinverters can provide equipment grounding of IronRidge systems, eliminating the need for grounding lugs and field installed equipment ground conductors (EGC). A minimum of two microinverters mounted to the same rail and connected to the same Engage cable is required. Refer to installation manuals for additional details.

UL Certification

The IronRidge® Flush Mount®, Tilt Mount®, and Ground Mount Systems have been listed to UL 2703 by Intertek Group plc.

UL 2703 is the standard for evaluating solar mounting systems. It ensures these devices will maintain strong electrical and mechanical connections over an extended period of time in extreme outdoor environments.

[Go to IronRidge.com/UFO](#)

Cross-System Compatibility

Feature	Flush Mount	Tilt Mount	Ground Mount
XR Rails®	✓	✓	XR100 & XR1000
UFO®/Stopper	✓	✓	✓
BOSS® Splice	✓	✓	N/A
Grounding Lugs	1 per Row	1 per Row	1 per Array
Microinverters & Power Optimizers	Compatible with most MLPE manufacturers. Refer to system installation manual.		
Fire Rating	Class A	Class A	N/A
Modules	Tested or Evaluated with over 400 Framed Modules. Refer to installation manuals for a detailed list.		

CONTRACTOR INFORMATION



PALMETTO SOLAR
ADDRESS: 997 MORRISON DRIVE,
SUITE 200, CHARLESTON, SC 29403
PHONE NUMBER: (855) 339-1831

CUSTOMER INFORMATION

NAME: EDUARDO CARRANZA
ADDRESS: 94 MARY ROBERTSON
STREET, DUNN, NC 28334
COORDINATES: 35.300304, -78.666147
APN: 0596946308000
6.075kW DC / 5.000kW AC ROOF
MOUNT PV SYSTEM

PROJECT ID	AUR-87459
DATE	10/17/2023
CREATED BY	NC
SIGNATURE	

UL CERTIFICATION
SS