

© 2023 NC SOLAR NOW EXPRESSLY RESERVES ITS COMMON LAW COPYRIGHT AND OTHER PROPERTY RIGHTS IN THESE PLANS. THESE PLANS ARE NOT TO BE REPRODUCED, CHANGED OR COPIED IN ANY FORM OR MANNER WHATSOEVER, NOR ARE THEY TO BE ASSIGNED TO ANY THIRD PARTY WITHOUT FIRST OBTAINING THE EXPRESSED WRITTEN PERMISSION AND CONSENT OF NC SOLAR NOW.



PV MATERIAL SUMMARY: DISTRIBUTOR	
REC400NP3 BLACK	22
IQ7PLUS-72-2-US	22
X2-IQ-AM1-240-4	1
Q-12-17-240	25
Q-SEAL-10	3
Q-TERM-10	2
XR-10-168B	12
XR-10-204B	3
XR10-BOSS-01-M1	6
UFO-CL-01-B1	58
UFO-STP-30MM-B1	28
XR-LUG-03-A1	7
QB DECK MOUNT 16317	37
4 IN QB1	30
MI-BHW	22
GC66803 Geocel Sealant	2
SOLADECK 0799-5B	2



CLIENT INFO
 JOHN TURNER
 86 THOMAS GAGE DR
 FUQUAY VARINA NC 27526

PROJECT INFO
 DC INPUT: 8.800 kW
 AC EXPORT: 6.380 kW
 DOI INSPT. METHOD: OPTION 2

Model Energy
 300 Fayetteville St.
 #1430
 Raleigh, NC 27602
 919-274-9905
 ModelEnergy.com
 P-1194

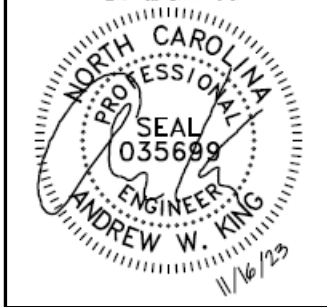

CODE REFERENCES
 NATION ELECTRICAL CODE v. 2017
 NC FIRE PROTECTION CODE v. 2018
 NC BUILDING CODE v. 2018
 NC RESIDENTIAL CODE v. 2018
 ACSE v. 7-10

SITE CONDITIONS
 WIND SPEED: 116 MPH
 RISK CATEGORY: II
 EXPOSURE: B
 SNOW: 15 PSF

SHEET INDEX
 PV-1: COVER SHEET
 PV-2: PV STRUCTURAL
 PV-3: PV ELECTRICAL
 PV-4: PV EQUIPMENT LABELS
 PV-5: PV INSTALL GUIDE

VERSIONS		
FOR:	DESIGNER	DATE
CONSTRUCTION	MCP	11/14/2023

PV SYSTEM COVER PAGE

PV-1.1

© 2023 NC SOLAR NOW EXPRESSLY RESERVES ITS COMMON LAW COPYRIGHT AND OTHER PROPERTY RIGHTS IN THESE PLANS. THESE PLANS ARE NOT TO BE REPRODUCED, CHANGED OR COPIED IN ANY FORM OR MANNER WHATSOEVER, NOR ARE THEY TO BE ASSIGNED TO ANY THIRD PARTY WITHOUT FIRST OBTAINING THE EXPRESSED WRITTEN PERMISSION AND CONSENT OF NC SOLAR NOW.

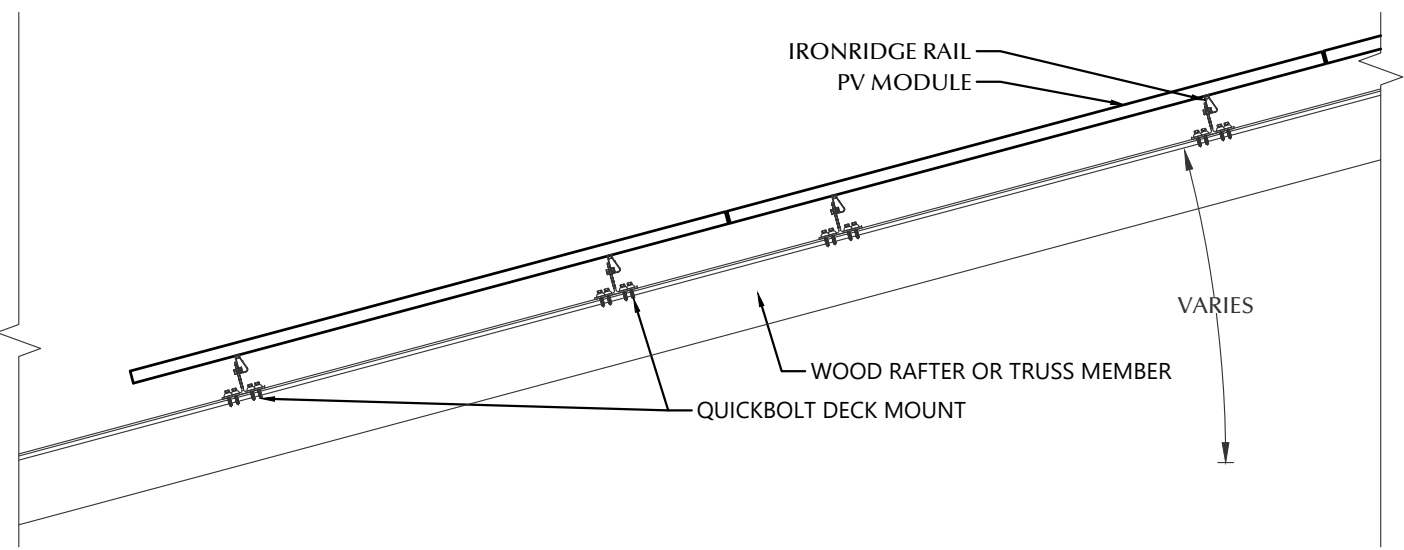

STATEMENT OF STRUCTURAL COMPLIANCE

THE EXISTING ROOF STRUCTURE HAS BEEN DESIGNED TO SUPPORT THE ADDITIONAL LOADS OF THE PROPOSED PV SYSTEM. IN ADDITION, THE RACKING AND FASTENING SYSTEM SHALL BE CAPABLE OF SECURING THE SYSTEM TO THE STRUCTURE UNDER DESIGN CONDITIONS WHEN INSTALLED PROPERLY AND IN ACCORDANCE WITH THE RACKING AND FASTENING ARRANGEMENT DETAILED WITHIN THESE DRAWINGS.

NAME: ANDREW W. KING, PE

SIGNED:

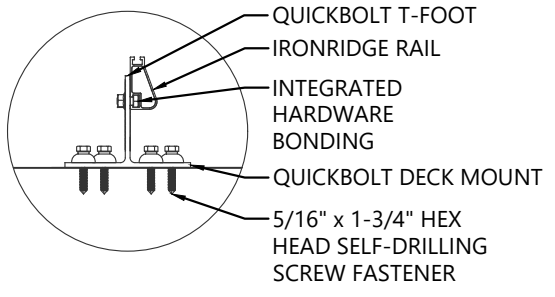
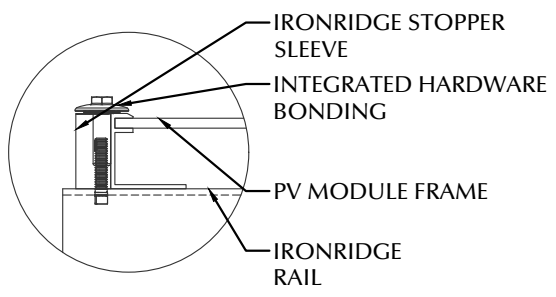
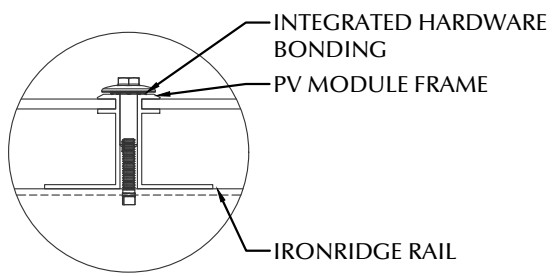
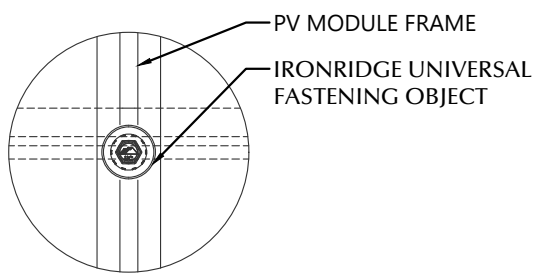
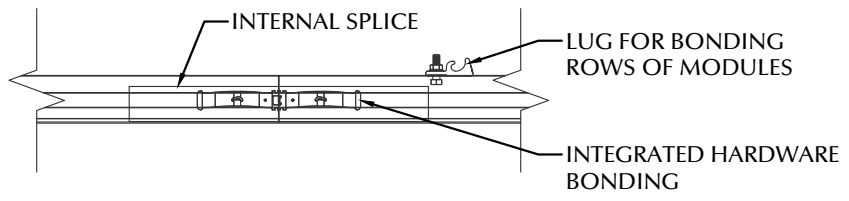

1 ROOF FASTENER DETAIL
NOT TO SCALE

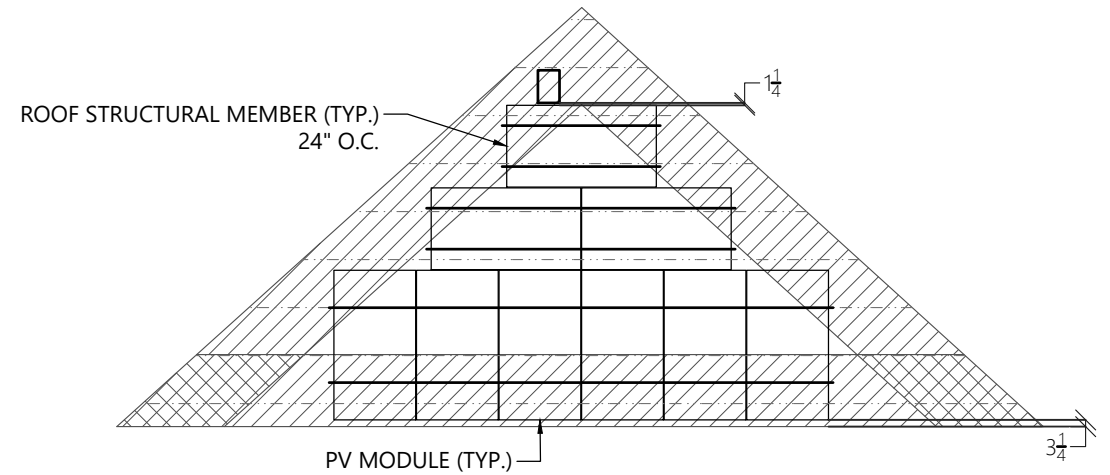

2 ROOF A ARRAY LAYOUT
1/8" = 1'-0"

PV MODULES	
MAKE	REC
MODEL	REC400NP3 BLACK
WIDTH	40.90 IN
LENGTH	74.80 IN
THICKNESS	30 MM
WEIGHT	47.00 LBS.
ARRAY AREA	191 SQFT.
ARRAY WEIGHT	478 LBS.

ROOF SUMMARY	
STRUCTURE:	
TYPE	TRUSSES
MATERIAL	SOUTHERN PINE #2
SIZE	2 X 4
SPACING	24 IN O.C.
ALLOWABLE SPAN	88 IN
PITCH	8/12
DENSITY	30 LBS./CU.FT.
DECKING:	
TYPE	OSB
MATERIAL	COMPOSITE
THICKNESS	7/16 IN
WEIGHT	1.60 LBS./SQFT
ROOFING:	
TYPE	ASPHALT SHINGLE
MATERIAL	ASPHALT
WEIGHT	2.30 LBS./SQFT.

ROOF MOUNT SUMMARY		
MAXIMUM (IN)	MOUNT SPACING	RAIL OVERHANG
WIND ZONE 1	PORT 36 LAND 67	14 IN
WIND ZONE 2	PORT 28 LAND 51	11 IN
WIND ZONE 3	PORT 24 LAND 45	9 IN

ROOF LOADING	
GROUND SNOW LOAD:	15 LBS./SQFT.
LIVE LOAD	20 LBS./SQFT.
DEAD LOAD	
ROOFING	3.9 LBS./SQFT.
PV ARRAY	2.5 LBS./SQFT.
TOTAL	6.4 LBS./SQFT.
WIND LOAD:	
UPLIFT ZONE 1	-24.6 LBS./SQFT.
UPLIFT ZONE 2	-29.0 LBS./SQFT.
UPLIFT ZONE 3	-29.0 LBS./SQFT.
DOWNWARD	23.0 LBS./SQFT.
FASTENER LOAD:	
UPLIFT ZONE 1	-234 LBS.
UPLIFT ZONE 2	-211 LBS.
UPLIFT ZONE 3	-194 LBS.
DOWNWARD	219 LBS.

ROOF MOUNT & FASTENER	
ROOF MOUNT:	
MAKE	QUICKBOLT
MODEL	QB DECK MOUNT 16317
MATERIAL	STAINLESS / EPDM
FASTENER:	
MAKE	QUICK SCREWS
MODEL	HEX LAG PN# 16318
MATERIAL	304 SS
SIZE	5/16" X 1-3/4"
GENERAL:	
WEIGHT	0.88 LBS.
FASTENERS PER MOUNT	4
MAX. PULL-OUT FORCE	705.0 LBS.
SAFETY FACTOR	3
DESIGN PULL-OUT FORCE	235.0 LBS.

MOUNTING RAILS	
MAKE	IRONRIDGE
MODEL	XR10
MATERIAL	ALUMINUM
WEIGHT	0.425 LBS/IN
SPACING	37 IN



CLIENT INFO
JOHN TURNER
86 THOMAS GAGE DR
FUQUAY VARINA NC 27526

PROJECT INFO
DC INPUT: 8.800 kW
AC EXPORT: 6.380 kW
DOI INSPT. METHOD: OPTION 2

Model Energy
300 Fayetteville St.
#1430
Raleigh, NC 27602
919-274-9905
ModelEnergy.com
P-1194

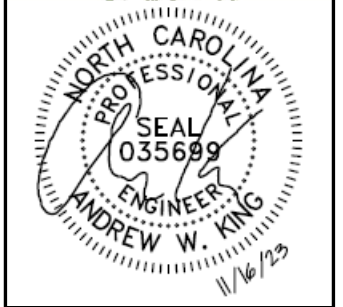

CODE REFERENCES
NATION ELECTRICAL CODE v. 2017
NC FIRE PROTECTION CODE v. 2018
NC BUILDING CODE v. 2018
NC RESIDENTIAL CODE v. 2018
ACSE v. 7-10

SITE CONDITIONS
WIND SPEED: 116 MPH
RISK CATEGORY: II
EXPOSURE: B
SNOW: 15 PSF

SHEET INDEX
PV-1: COVER SHEET
PV-2: PV STRUCTURAL
PV-3: PV ELECTRICAL
PV-4: PV EQUIPMENT LABELS
PV-5: PV INSTALL GUIDE

VERSIONS		
FOR:	DESIGNER	DATE
CONSTRUCTION	MCP	11/14/2023

PV SYSTEM STRUCTURAL

PV-2.1

© 2023 NC SOLAR NOW EXPRESSLY RESERVES ITS COMMON LAW COPYRIGHT AND OTHER PROPERTY RIGHTS IN THESE PLANS. THESE PLANS ARE NOT TO BE REPRODUCED, CHANGED OR COPIED IN ANY FORM OR MANNER WHATSOEVER, NOR ARE THEY TO BE ASSIGNED TO ANY THIRD PARTY WITHOUT FIRST OBTAINING THE EXPRESSED WRITTEN PERMISSION AND CONSENT OF NC SOLAR NOW.

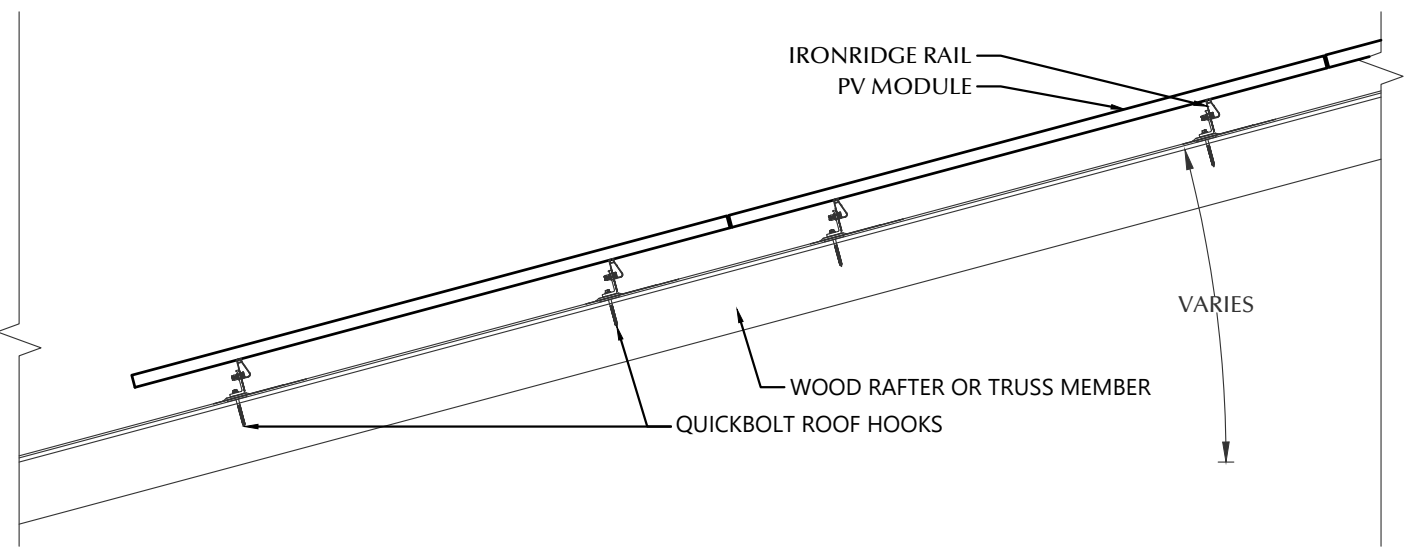

STATEMENT OF STRUCTURAL COMPLIANCE

THE EXISTING ROOF STRUCTURE HAS BEEN DESIGNED TO SUPPORT THE ADDITIONAL LOADS OF THE PROPOSED PV SYSTEM. IN ADDITION, THE RACKING AND FASTENING SYSTEM SHALL BE CAPABLE OF SECURING THE SYSTEM TO THE STRUCTURE UNDER DESIGN CONDITIONS WHEN INSTALLED PROPERLY AND IN ACCORDANCE WITH THE RACKING AND FASTENING ARRANGEMENT DETAILED WITHIN THESE DRAWINGS.

NAME: ANDREW W. KING, PE

SIGNED:

PV MODULES	
MAKE	REC
MODEL	REC400NP3 BLACK
WIDTH	40.90 IN
LENGTH	74.80 IN
THICKNESS	30 MM
WEIGHT	47.00 LBS.
ARRAY AREA	276 SQFT.
ARRAY WEIGHT	690 LBS.

ROOF SUMMARY	
STRUCTURE:	
TYPE	TRUSSES
MATERIAL	SOUTHERN PINE #2
SIZE	2 X 4
SPACING	24 IN O.C.
ALLOWABLE SPAN	88 IN
PITCH	6/12
DENSITY	30 LBS./CU.FT.
DECKING:	
TYPE	OSB
MATERIAL	COMPOSITE
THICKNESS	7/16 IN
WEIGHT	1.60 LBS./SQFT
ROOFING:	
TYPE	ASPHALT SHINGLE
MATERIAL	ASPHALT
WEIGHT	2.30 LBS./SQFT.



CLIENT INFO

JOHN TURNER
86 THOMAS GAGE DR
FUQUAY VARINA NC 27526

PROJECT INFO

DC INPUT: 8.800 kW
AC EXPORT: 6.380 kW
DOI INSPT. METHOD: OPTION 2

Model Energy

300 Fayetteville St.
#1430
Raleigh, NC 27602
919-274-9905
ModelEnergy.com

P-1194

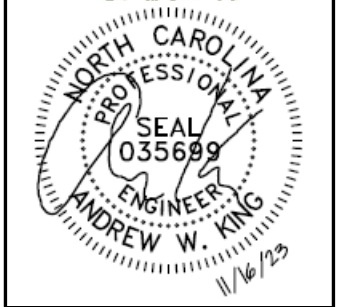

CODE REFERENCES

NATION ELECTRICAL CODE v. 2017
NC FIRE PROTECTION CODE v. 2018
NC BUILDING CODE v. 2018
NC RESIDENTIAL CODE v. 2018
ACSE v. 7-10

SITE CONDITIONS

WIND SPEED: 116 MPH
RISK CATEGORY: II
EXPOSURE: B
SNOW: 15 PSF

SHEET INDEX

PV-1: COVER SHEET
PV-2: PV STRUCTURAL
PV-3: PV ELECTRICAL
PV-4: PV EQUIPMENT LABELS
PV-5: PV INSTALL GUIDE

VERSIONS

FOR:	DESIGNER:	DATE:
CONSTRUCTION	MCP	11/14/2023

PV SYSTEM STRUCTURAL

PV-2.2

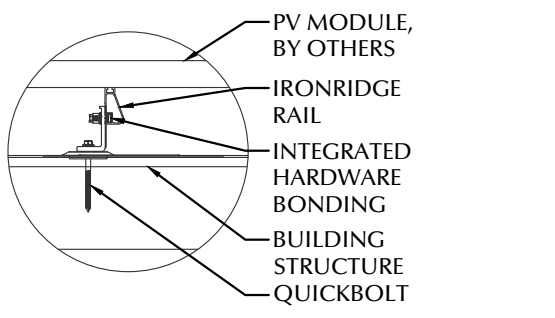
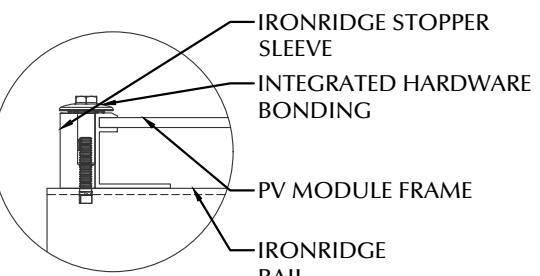
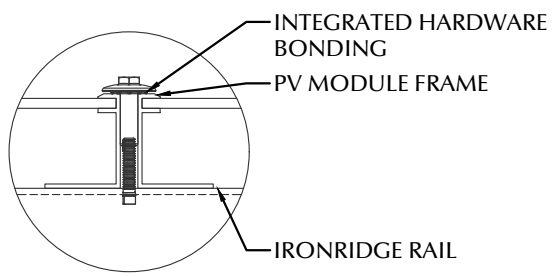
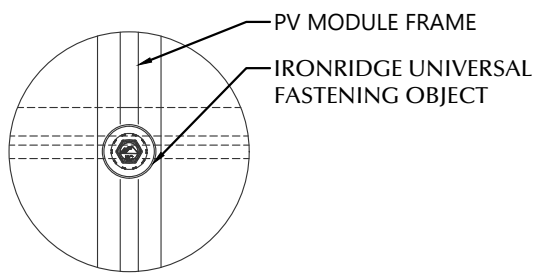
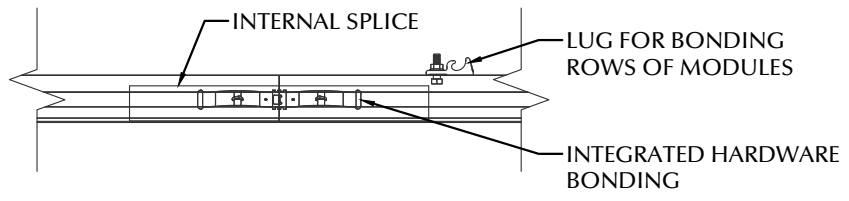

1 ROOF FASTENER DETAIL
NOT TO SCALE

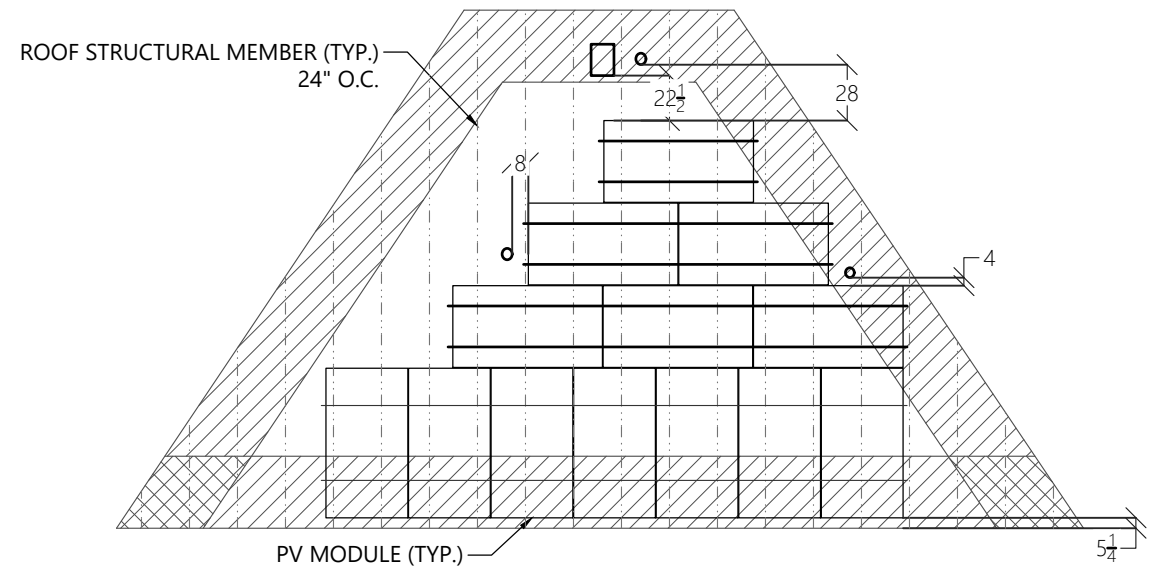

2 ROOF B ARRAY LAYOUT
1/8" = 1'-0"

ROOF MOUNT SUMMARY		
MAXIMUM (IN)	MOUNT SPACING	RAIL OVERHANG
WIND ZONE 1	PORT 72 LAND 72	24 IN
WIND ZONE 2	PORT 48 LAND 48	19 IN
WIND ZONE 3	PORT 48 LAND 48	19 IN

ROOF LOADING	
GROUND SNOW LOAD:	15 LBS./SQFT.
LIVE LOAD	20 LBS./SQFT.
DEAD LOAD	
ROOFING	3.9 LBS./SQFT.
PV ARRAY	2.5 LBS./SQFT.
TOTAL	6.4 LBS./SQFT.
WIND LOAD:	
UPLIFT ZONE 1	-24.6 LBS./SQFT.
UPLIFT ZONE 2	-29.0 LBS./SQFT.
UPLIFT ZONE 3	-29.0 LBS./SQFT.
DOWNWARD	23.0 LBS./SQFT.
FASTENER LOAD:	
UPLIFT ZONE 1	-331 LBS.
UPLIFT ZONE 2	-260 LBS.
UPLIFT ZONE 3	-260 LBS.
DOWNWARD	310 LBS.

ROOF MOUNT & FASTENER	
ROOF MOUNT:	
MAKE	QUICKBOLT
MODEL	4 IN QB1
MATERIAL	STAINLESS / EPDM
FASTENER:	
MAKE	QUICK SCREWS
MODEL	HANGER BOLT
MATERIAL	304 SS
SIZE	5/16-18 X 5-1/4"
GENERAL:	
WEIGHT	0.56 LBS.
FASTENERS PER MOUNT	1
MAX. PULL-OUT FORCE	960.0 LBS.
SAFETY FACTOR	2
DESIGN PULL-OUT FORCE	480.0 LBS.

MOUNTING RAILS	
MAKE	IRONRIDGE
MODEL	XR10
MATERIAL	ALUMINUM
WEIGHT	0.425 LBS/IN
SPACING	37 IN

© 2023 NC SOLAR NOW EXPRESSLY RESERVES ITS COMMON LAW COPYRIGHT AND OTHER PROPERTY RIGHTS IN THESE PLANS. THESE PLANS ARE NOT TO BE REPRODUCED, CHANGED OR COPIED IN ANY FORM OR MANNER WHATSOEVER, NOR ARE THEY TO BE ASSIGNED TO ANY THIRD PARTY WITHOUT FIRST OBTAINING THE EXPRESSED WRITTEN PERMISSION AND CONSENT OF NC SOLAR NOW.

CONDUCTOR SCHEDULE

TAG	CURRENT CARRYING CONDUCTORS			GROUNDING CONDUCTORS			CONDUIT/RACEWAY			NOTES
	QTY.	SIZE	INSULATION	QTY.	SIZE	INSULATION	QTY.	SIZE	LOCATION	
C1	4	12 AWG	DG CABLE	1	6 AWG	BARE	-	-	FREE AIR	1
C2	4	10 AWG	THWN-2	1	10 AWG	THWN-2	1	3/4"	EXT/INT	2,4
C3	3	8 AWG	THWN-2	1	10 AWG	THWN-2	1	3/4"	EXTERIOR	2,4
C4	3	6 AWG	THWN-2	1	6 AWG	THWN-2	1	1"	EXTERIOR	2,4
XC	-	-	-	-	-	-	-	-	-	3

NOTES:

1. MANUFACTURER PROVIDED, UL LISTED WIRING HARNESS FOR USE ON EXPOSED ROOFS
2. CONDUIT SIZE SHOWN IS CODE MINIMUM. LARGER SIZES ARE ALLOWED.
3. EXISTING CONDUCTORS, FIELD VERIFY
4. EQUIPMENT TERMINAL RATING SHALL BE A MINIMUM OF 75°C AT BOTH END OF CONDUCTOR

PV MODULE

MAKE	REC
MODEL	REC400NP3 BLACK
NOM. POWER (PNOM)	400 WATTS
NOM. VOLT. (VMPP)	37.6 VOLTS
O.C. VOLT (VOC)	45.0 VOLTS
MAX. SYS. VOLT.	1000 VOLTS
NOM. CURR. (IMPP)	10.6 AMPS
S.C. CURR. (ISC)	11.4 AMPS
TEMP. COEF. (PMPP)	-0.34 %/C
TEMP. COEF. (Voc)	-0.26 %/C
MAX SERIES FUSE	25 AMPS
UL COMPLIANT (Y/N)	YES

PV COMBINER PANEL

MAKE	ENPHASE
MODEL	X2-IQ-AM1-240-4
INPUT:	
MAX BRANCH CIRCUITS	4 TOTAL
BRANCH CIRCUIT OCPD	50 AMPS
OUTPUT:	
MAX POWER	15600 WATTS
NOM. VOLTAGE	240 VOLTS
BUS RATING	125 AMPS
MAIN BREAKER Y/N	NO
ENCL. RATING	NEMA TYPE 3R
UL LIST. (Y/N)	YES

DC / AC INVERTER

MAKE	ENPHASE
MODEL	IQ7PLUS-72-2-US
DC INPUT:	
POWER RANGE (WATTS)	235-440
MIN/MAX START VOLT.	22 / 60
OPERATING VOLT. RANGE	16-60
MAX. CURRENT	15 AMPS
MODULE COMPATIBILITY	60 & 72 CELL
AC OUTPUT:	
CEC EFFICIENCY	1 WATTS
NOM. POWER	290 WATTS
NOM. VOLT.	211-240-264
MAX. CURR.	1.21 AMPS
DC DISC. (Y/N)	NO
RAPID SHUTDOWN (Y/N)	YES
PROTECT. RATING	NEMA TYPE 6
UL LIST. (Y/N)	YES
MAX BRANCH CIRCUIT	13

SUB PANEL (EXISTING)

MAKE	SQUARE D
MODEL	QOC42UF
ENCL. RATING	NEMA 3R
VOLT. RATING	240 VOLTS
BUS RATING	225 AMPS
UL LIST. (Y/N)	YES
MAIN BREAKER (Y/N)	YES (NEW)
MAIN BREAKER RATING	200 AMPS

- INSTALL NEW 200A MAIN BREAKER IN SUB PANEL

JUNCTION BOX

MAKE	SOLADECK
PROTECT. RATING	NEMA TYPE 3R
UL LIST. (Y/N)	YES

METER COMBO (EXISTING)

MAKE	SQUARE D
MODEL	R200SFMG
ENCL. RATING	NEMA 3R
VOLT. RATING	240
AMP RATING	200 AMPS
UL LIST. (Y/N)	YES
MAIN BREAKER (Y/N)	YES
MAIN BREAKER RATING	200 AMPS

- BACK-FEED SOLAR OUTPUT VIA LOAD SIDE TAP IN BETWEEN OUTDOOR MAIN BREAKER AND NEW SUB PANEL MAIN BREAKER.
- MAIN BREAKER SERVES AS SERVICE DISCONNECT SWITCH

AC DISCONNECT

MAKE	GENERIC
MODEL	NA
ENCL. RATING	NEMA 3R
VOLT. RATING	240 VOLTS
AMP RATING	60 AMPS
UL LIST. (Y/N)	YES
FUSED (Y/N)	YES
FUSE RATING	35 AMPS

- LOAD-BREAK RATED
- VISIBLE OPEN
- LOCKABLE IN OPEN POSITION
- INSTALL ADJACENT TO METER
- DISCONNECT TO BE READILY ACCESSIBLE TO UTILITY COMPANY PERSONNEL AT ALL TIMES
- DISCONNECT MARKED AND RATED PER NEC SECTION 690.13 AND 705.10

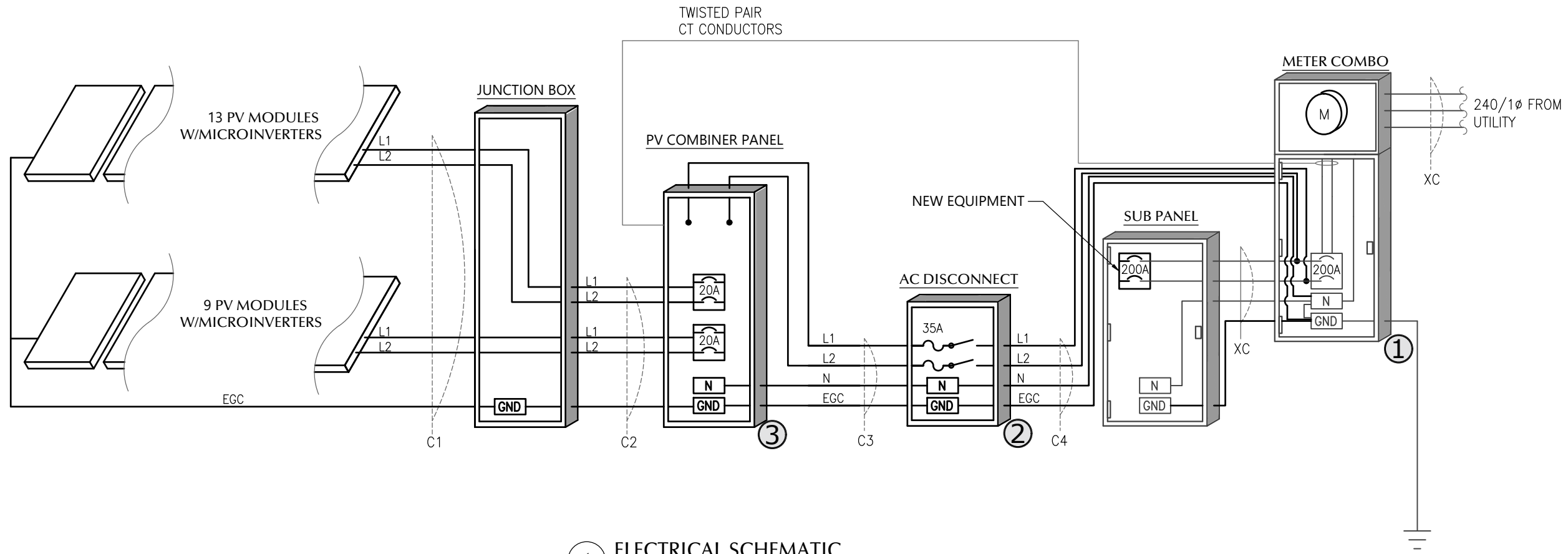

1 ELECTRICAL SCHEMATIC
NTS



CLIENT INFO

JOHN TURNER
86 THOMAS GAGE DR
FUQUAY VARINA NC 27526

PROJECT INFO

DC INPUT: 8.800 kW
AC EXPORT: 6.380 kW
DOI INSPT. METHOD: OPTION 2

Model Energy

300 Fayetteville St.
#1430
Raleigh, NC 27602
919-274-9905
ModelEnergy.com
P-1194

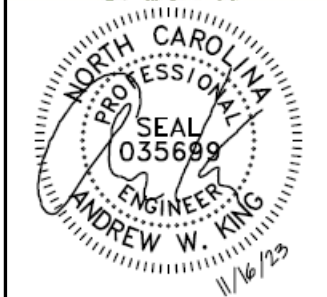

CODE REFERENCES

NATION ELECTRICAL CODE v. 2017
NC FIRE PROTECTION CODE v. 2018
NC BUILDING CODE v. 2018
NC RESIDENTIAL CODE v. 2018
ACSE v. 7-10

SITE CONDITIONS

WIND SPEED: 116 MPH
RISK CATEGORY: II
EXPOSURE: B
SNOW: 15 PSF

SHEET INDEX

PV-1: COVER SHEET
PV-2: PV STRUCTURAL
PV-3: PV ELECTRICAL
PV-4: PV EQUIPMENT LABELS
PV-5: PV INSTALL GUIDE

VERSIONS

FOR:	DESIGNER	DATE
CONSTRUCTION	MCP	11/14/2023

PV SYSTEM ELECTRICAL

PV-3.1

© 2023 NC SOLAR NOW EXPRESSLY RESERVES ITS COMMON LAW COPYRIGHT AND OTHER PROPERTY RIGHTS IN THESE PLANS. THESE PLANS ARE NOT TO BE REPRODUCED, CHANGED OR COPIED IN ANY FORM OR MANNER WHATSOEVER, NOR ARE THEY TO BE ASSIGNED TO ANY THIRD PARTY WITHOUT FIRST OBTAINING THE EXPRESSED WRITTEN PERMISSION AND CONSENT OF NC SOLAR NOW.

⚠ WARNING

PHOTOVOLTAIC SYSTEM
COMBINER PANEL

DO NOT ADD LOADS

③ NEC 705.12 (C)(3)
PLACE ON PV COMBINER PANEL

⚠ WARNING

THIS EQUIPMENT FED BY MULTIPLE SOURCES. TOTAL RATING OF ALL OVERCURRENT DEVICES EXCLUDING MAIN SUPPLY OVERCURRENT DEVICE SHALL NOT EXCEED AMPACITY OF BUSBAR.

③ NEC 705.12 (B)(2)(3)(c)
PLACE ON PV COMBINER PANEL.

RAPID SHUTDOWN SWITCH FOR SOLAR PV SYSTEM

② NEC 690.56 (C)(3)
PLACE ON RAPID SHUTDOWN SWITCH OR EQUIPMENT WITH INTEGRATED RAPID SHUTDOWN *REFLECTIVE*

PV SYSTEM DISCONNECT

② NEC 690.13 (B)
PLACE ON PV SYSTEM DISCONNECTING MEANS.

PHOTOVOLTAIC SYSTEM
AC DISCONNECT

OPERATING VOLTAGE **240** VOLTS

OPERATING CURRENT **26.62** AMPS

② NEC 690.54
PLACE ON INTERCONNECTION DISCONNECTING MEANS

⚠ WARNING

DUAL POWER SUPPLY

SOURCES: UTILITY GRID AND PV SOLAR ELECTRIC SYSTEM

① ③ NEC 705.12 (B)(3)
PLACE ON ALL EQUIPMENT THAT IS SUPPLIED BY BOTH POWER SOURCES

SOLAR PV SYSTEM EQUIPPED WITH RAPID SHUTDOWN

TURN RAPID SHUTDOWN SWITCH TO THE "OFF" POSITION TO SHUT DOWN PV SYSTEM AND REDUCE SHOCK HAZARD IN THE ARRAY

① NEC 690.56 (C)(1)(a)
PLACE WITHIN 3FT OF SERVICE DISCONNECTING MEANS TO WHICH THE PV SYSTEMS ARE CONNECTED AND SHALL INDICATE THE LOCATIONS OF RAPID SHUTDOWN SWITCHES

SERVICE DISCONNECT LOCATED:
SOUTH-WEST SIDE OF HOUSE

PV DISCONNECT LOCATED:
SOUTH-WEST SIDE OF HOUSE

① ② NEC 705.10
PLACE AT SERVICE EQUIPMENT AND PV SYSTEM DISCONNECTING MEANS. FIELD VERIFY EQUIPMENT LOCATIONS AND LABEL ACCORDINGLY.

LABEL NOTES

1. LABELS SHOWN ARE HALF THEIR ACTUAL REQUIRED SIZE.
2. LABEL MATERIAL SHALL BE SUITABLE FOR THE EQUIPMENT ENVIRONMENT.
3. DC CONDUIT SHALL BE MARKED WITH REQUIRED LABEL EVERY 10 FEET.
4. LABELS WILL BE APPLIED IN ACCORDANCE WITH THE NEC. SOME LABELS MAY NOT BE NECESSARY.

DC WIRING NOTES

1. CONDUCTORS SHALL BE COPPER, RATED AT NOT LESS THAN 600 VOLTS FOR RESIDENTIAL CONSTRUCTION AND NOT LESS THAN 1000 VOLTS FOR COMMERCIAL CONSTRUCTION.
2. MINIMUM SIZE SHALL BE #10 AWG UNLESS OTHERWISE NOTED ON THE DRAWINGS.
3. EXPOSED WIRING CONDUCTOR INSULATION SHALL BE TYPE PV WIRE, USE-2, OR RHW-2 WHERE THE OUTER LAYER OF THE INSULATION IS UV, SUNLIGHT, AND MOISTURE RESISTANT.
6. EXTERIOR WIRING CONDUCTOR INSULATION SHALL BE TYPE THWN-2 AND INSTALLED IN ELECTRICAL METALLIC TUBING(EMT) OR RIGID POLYVINYL CHLORIDE CONDUIT(PVC). ALTERNATIVELY, METAL CLAD CABLE(MC) CAN BE USED AS WELL WHEN RATED FOR USE IN WET LOCATIONS.
7. INTERIOR WIRING CONDUCTOR INSULATION SHALL BE TYPE THHN-2 AND INSTALLED IN ELECTRICAL METALLIC TUBING(EMT), FLEXIBLE METAL CONDUIT(FMC), OR METAL CLAD CABLE(MC).
6. USE SCHEDULE 40 PVC OUTDOORS WHERE NOT SUBJECT TO PHYSICAL DAMAGE OR BELOW FLOOR SLAB. USE SCHEDULE 80 PVC OUTDOORS WHERE SUBJECT TO PHYSICAL DAMMAGE
7. MINIMUM CONDUIT SIZE TO BE 1/2".
8. WIRING METHODS TO CONFORM TO ARTICLES 330, 334, 348, 350, 352, 356, AND 358 OF THE 2017 NEC.

AC WIRING NOTES

1. CONDUCTORS SHALL BE COPPER RATED AT NOT LESS THAN 600 VOLTS.
2. MINIMUM SIZE SHALL BE #14 AWG UNLESS OTHERWISE NOTED ON THE DRAWINGS.
3. EXTERIOR WIRING CONDUCTOR INSULATION SHALL BE TYPE THWN AND INSTALLED IN ELECTRICAL METALLIC TUBING(EMT), RIGID POLYVINYL CHLORIDE CONDUIT(PVC), LIQUID-TIGHT FLEXIBLE METAL CONDUIT(LFMC), OR LIQUID-TIGHT FLEXIBLE NON-METALLIC CONDUIT(LFNC) . ALTERNATIVELY, METAL CLAD CABLE(MC) CAN BE USED AS WELL WHEN RATED FOR USE IN WET LOCATIONS.
4. INTERIOR WIRING CONDUCTOR INSULATION SHALL BE TYPE THHN AND INSTALLED IN ELECTRICAL METALLIC TUBING(EMT), FLEXIBLE METAL CONDUIT(FMC), METAL CLAD CABLE(MC), OR ROMEX.
5. USE SCHEDULE 40 PVC OUTDOORS WHERE NOT SUBJECT TO PHYSICAL DAMAGE OR BELOW FLOOR SLAB. USE SCHEDULE 80 PVC OUTDOORS WHERE SUBJECT TO PHYSICAL DAMMAGE
6. MINIMUM CONDUIT SIZE TO BE 1/2".
7. WIRING METHODS TO CONFORM TO ARTICLES 330, 334, 348, 350, 352, 356, AND 358 OF THE 2017 NEC.

CONSTRUCTION NOTES

1. ALL WORK IS TO BE PERFORMED IN ACCORDANCE WITH THE NEC, STATE, AND LOCAL APPLICABLE CODES.
2. FOLLOW MANUFACTURER'S INSTALLATION INSTRUCTIONS, BEST PRACTICES, AND SPECIFICATIONS.
3. ENSURE REQUIRED MAINTENANCE ACCESS AND CLEARANCES ARE MAINTAINED.
4. WIRES SHALL BE RATED AND LABELED "SUNLIGHT RESISTANT" WHERE EXPOSED TO AMBIENT CONDITIONS.
5. FUSES 0 - 600 AMPS SHALL BE UL CLASS "RK-1" LOW PEAK DUAL ELEMENT TIME DELAY WITH 200,000 AMPERE INTERRUPTING RATING AS MANUFACTURED BY BUSSMANN, UNLESS NOTED OTHERWISE.
6. ALL TERMINALS/LUGS SHALL BE 75° RATED. ALL TERMINALS, SPlicing CONNECTORS, LUGS, ETC SHALL BE IDENTIFIED FOR USE WITH THE MATERIAL (CU/AL) OF THE CONDUCTOR AND SHALL BE PROPERLY INSTALLED.
7. PROVIDE A PULLWIRE IN ALL EMPTY CONDUITS.
8. ALL PENETRATIONS THROUGH EXTERIOR ROOFS SHALL BE FLASHED IN A WATERPROOF MANNER.
9. ALL PENETRATIONS THROUGH ATTIC FIRE BARRIERS SHALL BE SEALED WITH FIRE-BARRIER SEALANT CAULK.
10. SUPPORT ALL CONDUIT AND EQUIPMENT IN ACCORDANCE W/ NEC. ANY SUSPENDED MATERIALS SHALL BE DIRECTLY SUPPORTED BY THE BUILDING STRUCTURE.
11. METAL CONDUIT COUPLINGS CAN BE COMPRESSION TYPE, THREADED, OR BE SET-SCREW TYPE. PLASTIC CONDUIT COUPLINGS TO BE SOCKET GLUED TYPE.
12. A COMPLETE GROUNDING SYSTEM SHALL BE PRESENT OR PROVIDED AND INSTALLED IN ACCORDANCE WITH ARTICLE 250 OF THE NEC, AND AS SHOWN ON THE DRAWINGS.
13. EACH ELECTRICAL APPLIANCE SHALL BE PROVIDED WITH A NAMEPLATE GIVING THE IDENTIFYING NAME AND THE RATING IN VOLTS AND AMPERES, OR VOLTS AND WATTS. IF THE APPLIANCE IS TO BE USED ON A SPECIFIC FREQUENCY OR FREQUENCIES, IT SHALL BE SO MARKED. WHERE MOTOR OVERLOAD PROTECTION EXTERNAL TO THE APPLIANCES IS REQUIRED, THE APPLIANCE SHALL BE SO MARKED.
14. WHERE APPLICABLE, GROUNDING ELECTRODE CONDUCTOR TO BE CONTINUOUS. GROUNDING CRIMPS TO BE IRREVERSIBLE.
15. PHOTOVOLTAIC SYSTEMS SHALL BE PERMANENTLY MARKED AT VARIOUS EQUIPMENT LOCATIONS TO IDENTIFY THAT A PHOTOVOLTAIC SYSTEM IS INSTALLED AND THAT VARIOUS DANGERS ARE PRESENT.
16. EACH PHOTOVOLTAIC SYSTEM DISCONNECTING MEANS SHALL BE PERMANENTLY MARKED TO IDENTIFY IT AS A PHOTOVOLTAIC SYSTEM DISCONNECT.
17. WHERE ALL TERMINALS OF A DISCONNECTING MEANS MAY BE ENERGIZED IN THE OPEN POSITION, A WARNING SIGN SHALL BE MOUNTED ON OR ADJACENT TO THE DISCONNECT.
18. A PERMANENT LABEL FOR THE DIRECT-CURRENT PHOTOVOLTAIC POWER SOURCE SHALL BE PROVIDED AT THE DC DISCONNECT MEANS.
19. A PERMANENT PLAQUE OR DIRECTORY, DENOTING ALL ELECTRIC POWER SOURCES SERVING THE PREMISES, SHALL BE INSTALLED AT EACH SERVICE EQUIPMENT LOCATION AND AT LOCATIONS OF ALL POWER PRODUCTION SOURCES.
20. ALL MODULE GROUND CONNECTIONS SHALL BE MADE IN ACCORDANCE WITH NEC SECTION 690.4 (C).
21. A NORTH CAROLINA REGISTERED DESIGN PROFESSIONAL WILL BE REQUIRED TO SEAL THE STRUCTURAL DESIGN AT THE TIME OF PERMIT APPLICATION IF ANY OF THE FOLLOWING EXIST AND ARE ATTESTED TO BY THE APPLICANT:
 - I. THE WEIGHT OF THE PV SYSTEM EXCEEDS THREE (3) POUNDS PER SQUARE FOOT(PSF)
 - II. THE ROOF POSSESSES MORE THAN ONE (1) LAYER OF ASPHALT SHINGLES
 - III. THE ROOFING MATERIAL CONSISTS OF A TYPE OTHER THAN ASPHALT SHINGLES OR METAL
 - IV. THE ROOF IS LOCATED IN A 140 MPH OR GREATER WIND ZONE



CLIENT INFO

JOHN TURNER
86 THOMAS GAGE DR
FUQUAY VARINA NC 27526

PROJECT INFO

DC INPUT: 8.800 kW
AC EXPORT: 6.380 kW
DOI INSP. METHOD: OPTION 2

Model Energy

300 Fayetteville St.
#1430
Raleigh, NC 27602
919-274-9905
ModelEnergy.com

P-1194



CODE REFERENCES

NATION ELECTRICAL CODE v. 2017
NC FIRE PROTECTION CODE v. 2018
NC BUILDING CODE v. 2018
NC RESIDENTIAL CODE v. 2018
ACSE v. 7-10

SITE CONDITIONS

WIND SPEED: 116 MPH
RISK CATEGORY: II
EXPOSURE: B
SNOW: 15 PSF

SHEET INDEX

PV-1: COVER SHEET
PV-2: PV STRUCTURAL
PV-3: PV ELECTRICAL
PV-4: PV EQUIPMENT LABELS
PV-5: PV INSTALL GUIDE

VERSIONS

FOR:	DESIGNER	DATE
CONSTRUCTION	MCP	11/14/2023

PV SYSTEM EQUIPMENT LABELS

PV-4.1

© 2023 NC SOLAR NOW EXPRESSLY RESERVES ITS COMMON LAW COPYRIGHT AND OTHER PROPERTY RIGHTS IN THESE PLANS. THESE PLANS ARE NOT TO BE REPRODUCED, CHANGED OR COPIED IN ANY FORM OR MANNER WHATSOEVER, NOR ARE THEY TO BE ASSIGNED TO ANY THIRD PARTY WITHOUT FIRST OBTAINING THE EXPRESSED WRITTEN PERMISSION AND CONSENT OF NC SOLAR NOW.

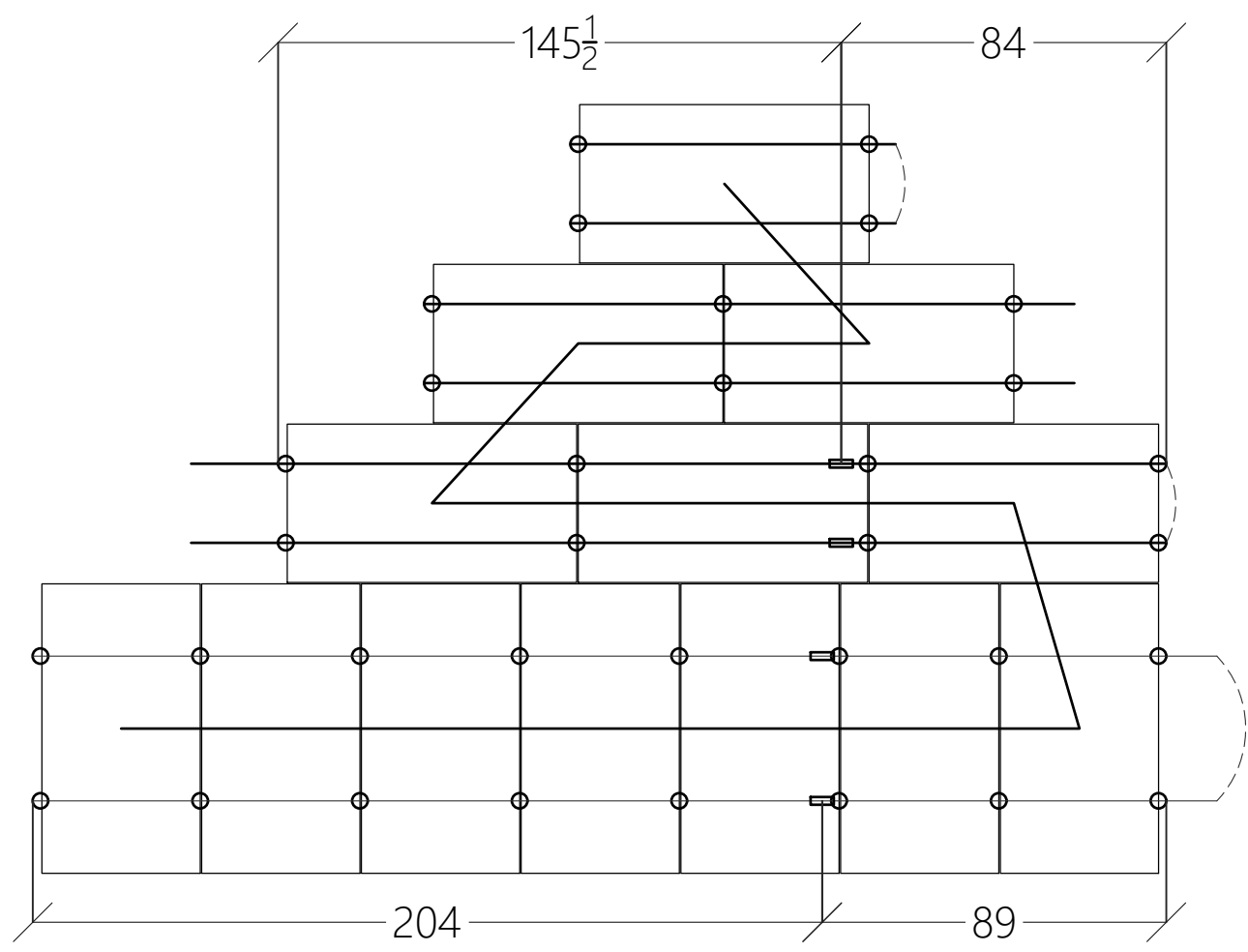
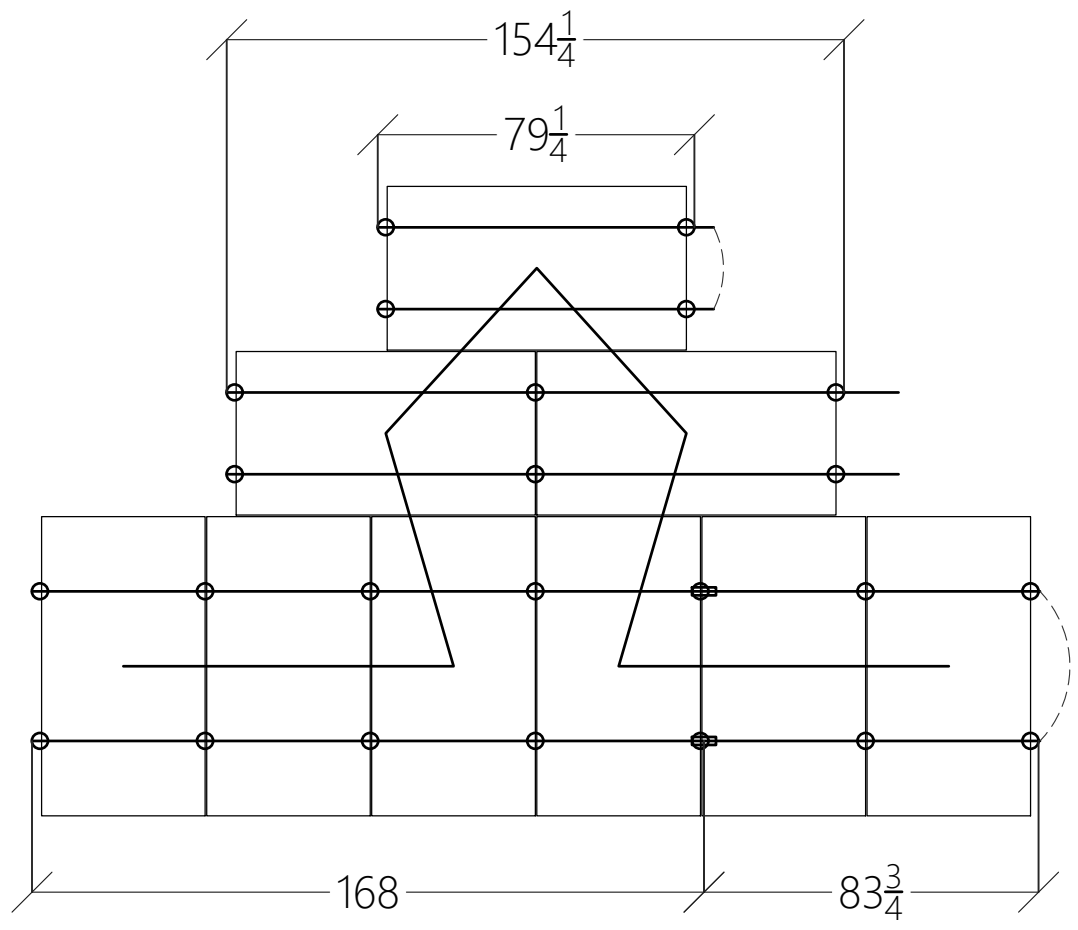

1 ARRAY LAYOUT DETAIL
NOT TO SCALE



CLIENT INFO
 JOHN TURNER
 86 THOMAS GAGE DR
 FUQUAY VARINA NC 27526

PROJECT INFO
 DC INPUT: 8.800 kW
 AC EXPORT: 6.380 kW
 DOI INSPT. METHOD: OPTION 2

Model Energy
 300 Fayetteville St.
 #1430
 Raleigh, NC 27602
 919-274-9905
 ModelEnergy.com
 P-1194



CODE REFERENCES
 NATION ELECTRICAL CODE v. 2017
 NC FIRE PROTECTION CODE v. 2018
 NC BUILDING CODE v. 2018
 NC RESIDENTIAL CODE v. 2018
 ACSE v. 7-10

SITE CONDITIONS
 WIND SPEED: 116 MPH
 RISK CATEGORY: II
 EXPOSURE: B
 SNOW: 15 PSF

SHEET INDEX
 PV-1: COVER SHEET
 PV-2: PV STRUCTURAL
 PV-3: PV ELECTRICAL
 PV-4: PV EQUIPMENT LABELS
 PV-5: PV INSTALL GUIDE

VERSIONS

FOR:	DESIGNER	DATE
CONSTRUCTION	MCP	11/14/2023

PV SYSTEM INSTALL GUIDE

PV-5.1

SOLAR'S MOST TRUSTED

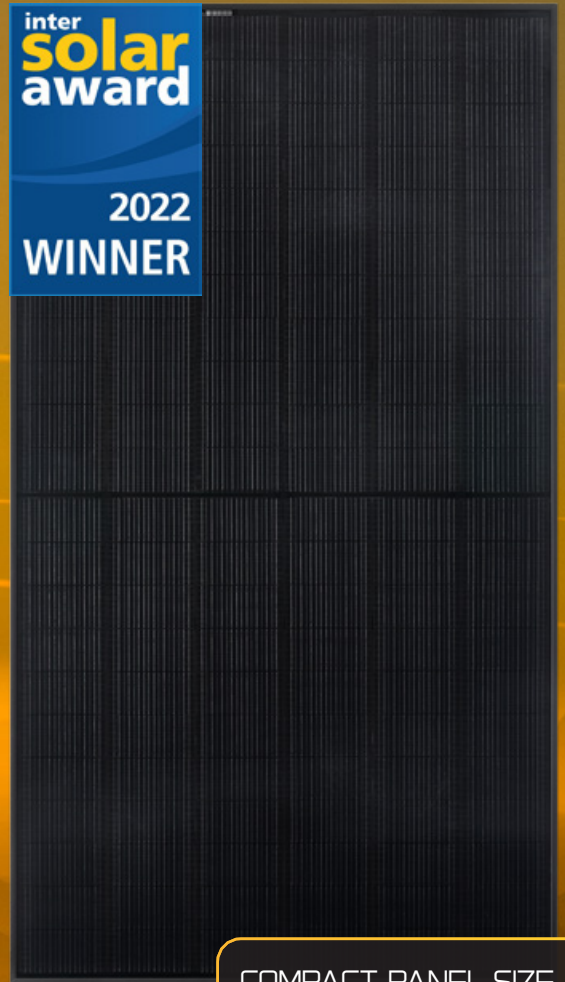

REC ALPHA[®] PURE SERIES

PRODUCT SPECIFICATIONS

410 WP
20.6 W/FT²
22.2% EFFICIENCY

PRODUCT
LABOR
PERFORMANCE
REC 25 YEAR PROTRUST WARRANTY
ELIGIBLE

LEAD-FREE
ROHS COMPLIANT

EXPERIENCE
PERFORMANCE

REC ALPHA PURE SERIES

PRODUCT SPECIFICATIONS

GENERAL DATA

Cell type:	132 half-cut REC heterojunction bifacial cells with lead-free, gapless technology, 6 strings of 22 cells in series
Glass:	0.13in(3.2mm)solar glass with anti-reflective surface treatment in accordance with EN12150
Backsheet:	Highly resistant polymer (black)
Frame:	Anodized aluminum (black)
Junction box:	3-part, 3 bypass diodes, lead-free IP68 rated, in accordance with IEC 62790
Connectors:	Stäubli MC4 PV-KBT4/KST4 (4 mm ²) in accordance with IEC 62852, IP68 only when connected
Cable:	12 AWG (4 mm ²) PV wire, 43+ 47 in (1.1 + 1.2 m) in accordance with EN 50618
Dimensions:	71.7 x 40 x 1.2 in (19.91 ft ²) / 1821 x 1016 x 30 mm (1.85 m ²)
Weight:	45 lbs (20.5 kg)
Origin:	Made in Singapore

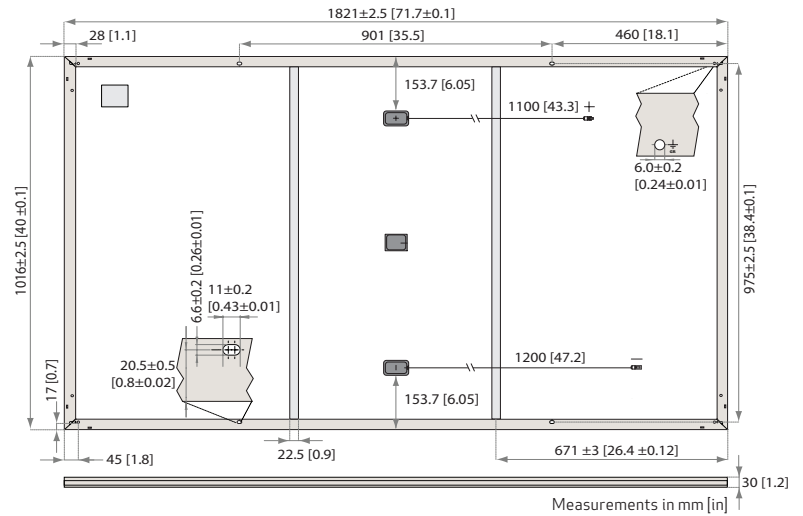

ELECTRICAL DATA

Product Code*: RECxxxAA Pure

	390	395	400	405	410
Power Output - P _{MAX} (Wp)	390	395	400	405	410
Watt Class Sorting - (W)	0/+5	0/+5	0/+5	0/+5	0/+5
Nominal Power Voltage - V _{MPP} (V)	40.6	41.0	41.4	41.8	42.2
Nominal Power Current - I _{MPP} (A)	9.61	9.64	9.67	9.69	9.72
Open Circuit Voltage - V _{OC} (V)	48.4	48.6	48.8	49.1	49.4
Short Circuit Current - I _{SC} (A)	10.38	10.39	10.40	10.41	10.42
Power Density (W/ft ²)	19.6	19.8	20.1	20.3	20.6
Panel Efficiency (%)	21.1	21.4	21.6	21.9	22.2
Power Output - P _{MAX} (Wp)	297	301	305	308	312
Nominal Power Voltage - V _{MPP} (V)	38.3	38.6	39.0	39.4	39.8
Nominal Power Current - I _{MPP} (A)	7.77	7.79	7.82	7.83	7.85
Open Circuit Voltage - V _{OC} (V)	45.6	45.8	46.0	46.3	46.6
Short Circuit Current - I _{SC} (A)	8.38	8.39	8.40	8.41	8.42

Values at standard test conditions (STC: air mass AM1.5, irradiance 10.75 W/sq ft (1000 W/m²), temperature 77°F (25°C), based on a production spread with a tolerance of P_{MAX}, V_{OC} & I_{SC} ±3% within one watt class. Nominal module operating temperature (NMO: air mass AM1.5, irradiance 800 W/m², temperature 68°F (20°C), windspeed 3.3 ft/s (1 m/s). *Where xxx indicates the nominal power class (P_{MAX}) at STC above.

MAXIMUM RATINGS

Operational temperature:	-40 ... +85°C
Maximum system voltage:	1000 V
Maximum test load (front):	+7000 Pa (146 lbs/ft ²)*
Maximum test load (rear):	-4000 Pa (83.5 lbs/ft ²)*
Max series fuse rating:	25 A
Max reverse current:	25 A

*See installation manual for mounting instructions.
Design load = Test load / 1.5 (safety factor)

WARRANTY

	Standard	REC ProTrust	
Installed by an REC Certified Solar Professional	No	Yes	Yes
System Size	All	≤25 kW	25-500 kW
Product Warranty (yrs)	20	25	25
Power Warranty (yrs)	25	25	25
Labor Warranty (yrs)	0	25	10
Power in Year 1	98%	98%	98%
Annual Degradation	0.25%	0.25%	0.25%
Power in Year 25	92%	92%	92%

See warranty documents for details. Conditions apply

CERTIFICATIONS

IEC 61215:2016, IEC 61730:2016, UL 61730	
IEC 62804	PID
IEC 61701	Salt Mist
IEC 62716	Ammonia Resistance
UL 61730	Fire Type Class 2
IEC 62782	Dynamic Mechanical Load
IEC 61215-2:2016	Hailstone (35mm)
IEC 62321	Lead-free acc. to RoHS EU 863/2015
ISO 14001, ISO 9001, IEC 45001, IEC 62941	



TEMPERATURE RATINGS*

Nominal Module Operating Temperature:	44°C (±2°C)
Temperature coefficient of P _{MAX} :	-0.26%/°C
Temperature coefficient of V _{OC} :	-0.24%/°C
Temperature coefficient of I _{SC} :	0.04%/°C

*The temperature coefficients stated are linear values

DELIVERY INFORMATION

Panels per pallet:	33
Panels per 40 ft GP/high cube container:	792 (24 pallets)
Panels per 53 ft truck:	891 (27 pallets)

LOW LIGHT BEHAVIOUR

Typical low irradiance performance of module at STC:

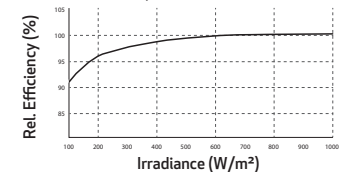

Available from:

Founded in 1996, REC Group is an international pioneering solar energy company dedicated to empowering consumers with clean, affordable solar power. As Solar's Most Trusted, REC is committed to high quality, innovation, and a low carbon footprint in the solar materials and solar panels it manufactures. Headquartered in Norway with operational headquarters in Singapore, REC also has regional hubs in North America, Europe, and Asia-Pacific.

REC Solar PTE. LTD.
20 Tuas South Ave. 14
Singapore 637312
post@recgroup.com



Enphase IQ Combiner 4/4C

X-IQ-AM1-240-4
X-IQ-AM1-240-4C



The **Enphase IQ Combiner 4/4C** with Enphase IQ Gateway and integrated LTE-M1 cell modem (included only with IQ Combiner 4C) consolidates interconnection equipment into a single enclosure and streamlines IQ microinverters and storage installations by providing a consistent, pre-wired solution for residential applications. It offers up to four 2-pole input circuits and Eaton BR series busbar assembly.

Smart

- Includes IQ Gateway for communication and control
- Includes Enphase Mobile Connect cellular modem (CELLMODEM-M1-06-SP-05), included only with IQ Combiner 4C
- Includes solar shield to match Enphase IQ Battery aesthetics and deflect heat
- Flexible networking supports Wi-Fi, Ethernet, or cellular
- Optional AC receptacle available for PLC bridge
- Provides production metering and consumption monitoring

Simple

- Centered mounting brackets support single stud mounting
- Supports bottom, back and side conduit entry
- Up to four 2-pole branch circuits for 240 VAC plug-in breakers (not included)
- 80A total PV or storage branch circuits

Reliable

- Durable NRTL-certified NEMA type 3R enclosure
- Five-year limited warranty
- Two years labor reimbursement program coverage included for both the IQ Combiner SKU's
- UL listed



To learn more about Enphase offerings, visit enphase.com

Enphase IQ Combiner 4/4C

MODEL NUMBER

IQ Combiner 4 (X-IQ-AM1-240-4)	IQ Combiner 4 with Enphase IQ Gateway printed circuit board for integrated revenue grade PV production metering (ANSI C12.20 +/- 0.5%) and consumption monitoring (+/- 2.5%). Includes a silver solar shield to match the IQ Battery system and IQ System Controller 2 and to deflect heat.
IQ Combiner 4C (X-IQ-AM1-240-4C)	IQ Combiner 4C with Enphase IQ Gateway printed circuit board for integrated revenue grade PV production metering (ANSI C12.20 +/- 0.5%) and consumption monitoring (+/- 2.5%). Includes Enphase Mobile Connect cellular modem (CELLMODEM-M1-06-SP-05), a plug-and-play industrial-grade cell modem for systems up to 60 microinverters. (Available in the US, Canada, Mexico, Puerto Rico, and the US Virgin Islands, where there is adequate cellular service in the installation area.) Includes a silver solar shield to match the IQ Battery and IQ System Controller and to deflect heat.

ACCESSORIES AND REPLACEMENT PARTS (not included, order separately)

Ensemble Communications Kit COMMS-CELLMODEM-M1-06 CELLMODEM-M1-06-SP-05 CELLMODEM-M1-06-AT-05	- Includes COMMS-KIT-01 and CELLMODEM-M1-06-SP-05 with 5-year Sprint data plan for Ensemble sites - 4G based LTE-M1 cellular modem with 5-year Sprint data plan - 4G based LTE-M1 cellular modem with 5-year AT&T data plan
Circuit Breakers BRK-10A-2-240V BRK-15A-2-240V BRK-20A-2P-240V BRK-15A-2P-240V-B BRK-20A-2P-240V-B	Supports Eaton BR210, BR215, BR220, BR230, BR240, BR250, and BR260 circuit breakers. Circuit breaker, 2 pole, 10A, Eaton BR210 Circuit breaker, 2 pole, 15A, Eaton BR215 Circuit breaker, 2 pole, 20A, Eaton BR220 Circuit breaker, 2 pole, 15A, Eaton BR215B with hold down kit support Circuit breaker, 2 pole, 20A, Eaton BR220B with hold down kit support
EPLC-01	Power line carrier (communication bridge pair), quantity - one pair
XA-SOLARSHIELD-ES	Replacement solar shield for IQ Combiner 4/4C
XA-PLUG-120-3	Accessory receptacle for Power Line Carrier in IQ Combiner 4/4C (required for EPLC-01)
XA-ENV-PCBA-3	Replacement IQ Gateway printed circuit board (PCB) for Combiner 4/4C
X-IQ-NA-HD-125A	Hold down kit for Eaton circuit breaker with screws.

ELECTRICAL SPECIFICATIONS

Rating	Continuous duty
System voltage	120/240 VAC, 60 Hz
Eaton BR series busbar rating	125 A
Max. continuous current rating	65 A
Max. continuous current rating (input from PV/storage)	64 A
Max. fuse/circuit rating (output)	90 A
Branch circuits (solar and/or storage)	Up to four 2-pole Eaton BR series Distributed Generation (DG) breakers only (not included)
Max. total branch circuit breaker rating (input)	80A of distributed generation / 95A with IQ Gateway breaker included
Production metering CT	200 A solid core pre-installed and wired to IQ Gateway
Consumption monitoring CT (CT-200-SPLIT)	A pair of 200 A split core current transformers

MECHANICAL DATA

Dimensions (WxHxD)	37.5 x 49.5 x 16.8 cm (14.75" x 19.5" x 6.63"). Height is 21.06" (53.5 cm) with mounting brackets.
Weight	7.5 kg (16.5 lbs)
Ambient temperature range	-40° C to +46° C (-40° to 115° F)
Cooling	Natural convection, plus heat shield
Enclosure environmental rating	Outdoor, NRTL-certified, NEMA type 3R, polycarbonate construction
Wire sizes	<ul style="list-style-type: none">• 20 A to 50 A breaker inputs: 14 to 4 AWG copper conductors• 60 A breaker branch input: 4 to 1/0 AWG copper conductors• Main lug combined output: 10 to 2/0 AWG copper conductors• Neutral and ground: 14 to 1/0 copper conductors Always follow local code requirements for conductor sizing.
Altitude	To 2000 meters (6,560 feet)

INTERNET CONNECTION OPTIONS

Integrated Wi-Fi	802.11b/g/n
Cellular	CELLMODEM-M1-06-SP-05, CELLMODEM-M1-06-AT-05 (4G based LTE-M1 cellular modem). Note that an Enphase Mobile Connect cellular modem is required for all Ensemble installations.
Ethernet	Optional, 802.3, Cat5E (or Cat 6) UTP Ethernet cable (not included)

COMPLIANCE

Compliance, IQ Combiner	UL 1741, CAN/CSA C22.2 No. 107.1, 47 CFR, Part 15, Class B, ICES 003 Production metering: ANSI C12.20 accuracy class 0.5 (PV production) Consumption metering: accuracy class 2.5
Compliance, IQ Gateway	UL 60601-1/CANCSA 22.2 No. 61010-1

To learn more about Enphase offerings, visit enphase.com



© 2021 Enphase Energy. All rights reserved. Enphase, the Enphase logo, IQ Combiner 4/4C, and other names are trademarks of Enphase Energy, Inc. Data subject to change. 10-21-2021

Enphase IQ 7 and IQ 7+ Microinverters

The high-powered smart grid-ready **Enphase IQ 7 Micro™** and **Enphase IQ 7+ Micro™** dramatically simplify the installation process while achieving the highest system efficiency.

Part of the Enphase IQ System, the IQ 7 and IQ 7+ Microinverters integrate with the Enphase IQ Envoy™, Enphase IQ Battery™, and the Enphase Enlighten™ monitoring and analysis software.

IQ Series Microinverters extend the reliability standards set forth by previous generations and undergo over a million hours of power-on testing, enabling Enphase to provide an industry-leading warranty of up to 25 years.

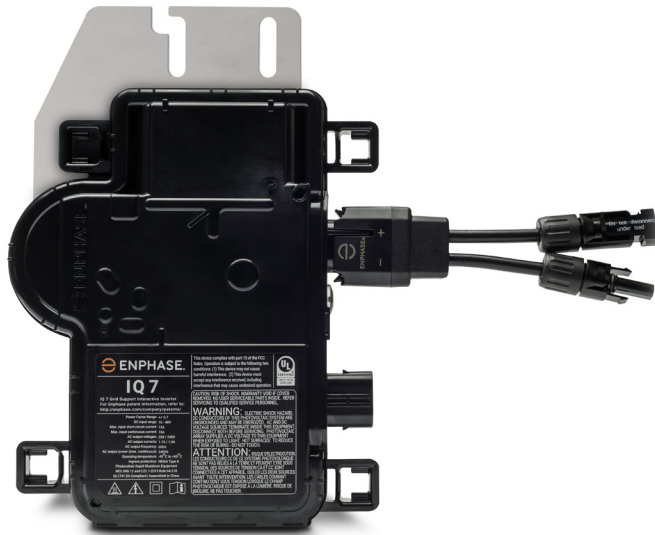

Easy to Install

- Lightweight and simple
- Faster installation with improved, lighter two-wire cabling
- Built-in rapid shutdown compliant (NEC 2014 & 2017)

Productive and Reliable

- Optimized for high powered 60-cell and 72-cell* modules
- More than a million hours of testing
- Class II double-insulated enclosure
- UL listed

Smart Grid Ready

- Complies with advanced grid support, voltage and frequency ride-through requirements
- Remotely updates to respond to changing grid requirements
- Configurable for varying grid profiles
- Meets CA Rule 21 (UL 1741-SA)

* The IQ 7+ Micro is required to support 72-cell modules.



Enphase IQ 7 and IQ 7+ Microinverters

INPUT DATA (DC)	IQ7-60-2-US		IQ7PLUS-72-2-US	
Commonly used module pairings ¹	235 W - 350 W +		235 W - 440 W +	
Module compatibility	60-cell PV modules only		60-cell and 72-cell PV modules	
Maximum input DC voltage	48 V		60 V	
Peak power tracking voltage	27 V - 37 V		27 V - 45 V	
Operating range	16 V - 48 V		16 V - 60 V	
Min/Max start voltage	22 V / 48 V		22 V / 60 V	
Max DC short circuit current (module I _{sc})	15 A		15 A	
Overvoltage class DC port	II		II	
DC port backfeed current	0 A		0 A	
PV array configuration	1 x 1 ungrounded array; No additional DC side protection required; AC side protection requires max 20A per branch circuit			
OUTPUT DATA (AC)	IQ 7 Microinverter		IQ 7+ Microinverter	
Peak output power	250 VA		295 VA	
Maximum continuous output power	240 VA		290 VA	
Nominal (L-L) voltage/range ²	240 V / 211-264 V	208 V / 183-229 V	240 V / 211-264 V	208 V / 183-229 V
Maximum continuous output current	1.0 A (240 V)	1.15 A (208 V)	1.21 A (240 V)	1.39 A (208 V)
Nominal frequency	60 Hz		60 Hz	
Extended frequency range	47 - 68 Hz		47 - 68 Hz	
AC short circuit fault current over 3 cycles	5.8 Arms		5.8 Arms	
Maximum units per 20 A (L-L) branch circuit ³	16 (240 VAC)	13 (208 VAC)	13 (240 VAC)	11 (208 VAC)
Overvoltage class AC port	III		III	
AC port backfeed current	18 mA		18 mA	
Power factor setting	1.0		1.0	
Power factor (adjustable)	0.85 leading ... 0.85 lagging		0.85 leading ... 0.85 lagging	
EFFICIENCY	@240 V	@208 V	@240 V	@208 V
Peak efficiency	97.6 %	97.6 %	97.5 %	97.3 %
CEC weighted efficiency	97.0 %	97.0 %	97.0 %	97.0 %
MECHANICAL DATA				
Ambient temperature range	-40°C to +65°C			
Relative humidity range	4% to 100% (condensing)			
Connector type	MC4 (or Amphenol H4 UTX with additional Q-DCC-5 adapter)			
Dimensions (HxWxD)	212 mm x 175 mm x 30.2 mm (without bracket)			
Weight	1.08 kg (2.38 lbs)			
Cooling	Natural convection - No fans			
Approved for wet locations	Yes			
Pollution degree	PD3			
Enclosure	Class II double-insulated, corrosion resistant polymeric enclosure			
Environmental category / UV exposure rating	NEMA Type 6 / outdoor			
FEATURES				
Communication	Power Line Communication (PLC)			
Monitoring	Enlighten Manager and MyEnlighten monitoring options. Both options require installation of an Enphase IQ Envoy.			
Disconnecting means	The AC and DC connectors have been evaluated and approved by UL for use as the load-break disconnect required by NEC 690.			
Compliance	CA Rule 21 (UL 1741-SA) UL 62109-1, UL1741/IEEE1547, FCC Part 15 Class B, ICES-0003 Class B, CAN/CSA-C22.2 NO. 107.1-01 This product is UL Listed as PV Rapid Shut Down Equipment and conforms with NEC-2014 and NEC-2017 section 690.12 and C22.1-2015 Rule 64-218 Rapid Shutdown of PV Systems, for AC and DC conductors, when installed according manufacturer's instructions.			

1. No enforced DC/AC ratio. See the compatibility calculator at <https://enphase.com/en-us/support/module-compatibility>.

2. Nominal voltage range can be extended beyond nominal if required by the utility.

3. Limits may vary. Refer to local requirements to define the number of microinverters per branch in your area.

To learn more about Enphase offerings, visit enphase.com



RSTC Enterprises, Inc.
2214 Heimstead Road
Eau Claire, WI 54703
715-830-9997



Outdoor Photovoltaic Enclosures

Composition/Cedar Roof System

ETL listed and labeled

Report # 3171411PRT-002 Revised May, 2018

- UL50 Type 3R, 11 Edition Electrical equipment enclosures
- CSA C22.2 No. 290 Nema Type 3R
- Conforms to UL 1741 Standard

0799 Series Includes:

- | | |
|----------|------------------|
| 0799 - 2 | Wire size 2/0-14 |
| 0799 - 5 | Wire size 14-6 |
| 0799 - D | Wire size 14-8 |

Models available in Grey, Black or Stainless Steel

Basic Specifications

Material options:

- Powder coated, 18 gauge galvanized 90 steel (1,100 hours salt spray)
- Stainless steel

Process - Seamless draw (stamped)

Flashing - 15.25" x 17.25"

Height - 3"

Cavity - 255 Cubic inches

Base Plate:

- Fastened to base using toggle fastening system
- 5 roof deck knockouts
- Knockout sizes: (3) .5", (1) .75" and (1) 1"
- 8", 35mm slotted din rail
- Ground Block

Passthrough and combiner kits are available for either AC or DC applications.

0799 Series

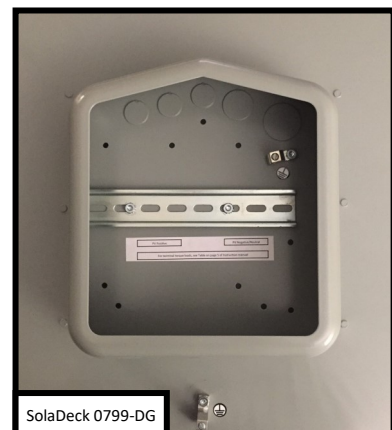
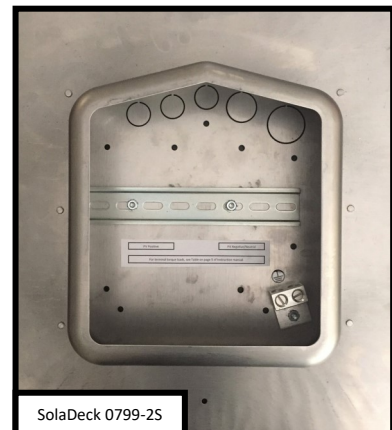

D322NRB

Safety switch, general duty, fusible, 60A, 3 poles, 15 hp, 240 VAC, NEMA 3R, bolt-on provision, neutral factory installed



Main

Product	Single Throw Safety Switch
Duty Rating	General duty
Device Application	Residential
Disconnect Type	Fusible disconnect switch
Factory Installed Neutral	Neutral (factory installed)
Phase	3 phase
Number of Poles	3
Current Rating	60 A
Voltage Rating	240 V AC
Enclosure Rating NEMA	NEMA 3R
Motor power hp	1.5 Hp at 120 V AC 60 Hz for 1 phase motors 3 Hp at 120 V AC 60 Hz for 3 phase motors 3 Hp at 240 V AC 60 Hz for 1 phase motors 7.5 Hp at 240 V AC 60 Hz for 3 phase motors 10 Hp at 240 V AC 60 Hz for 1 phase motors 15 hp at 240 V AC 60 Hz for 3 phase motors

Complementary

Short Circuit Current Rating	100 kA maximum depending on fuse H, K or R
Fuse type	H, K or R
Mounting Type	Surface
Electrical Connection	Lugs
Wiring configuration	4-wire (3PH + G)
Wire Size	AWG 12...AWG 3 aluminium AWG 14...AWG 3 copper
Tightening torque	35 Lbf.In (3.95 N.m) 0.00...0.01 in ² (2.08...5.26 mm ²) (AWG 14...AWG 10) 35 Lbf.In (3.95 N.m) (AWG 14...AWG 10) 45 Lbf.In (5.08 N.m) 0.01 in ² (8.37 mm ²) (AWG 8) 45 Lbf.In (5.08 N.m) 0.02...0.03 in ² (12.3...21.12 mm ²) (AWG 6...AWG 4) 50 lbf.in (5.65 N.m) 0.04 in ² (26.67 mm ²) (AWG 3)
Depth	4.87 in (123.70 mm)
Width	7.45 in (189.23 mm)
Height	14.88 in (377.95 mm)
Net Weight	9.92 lb(US) (4.5 kg)

Environment

Certifications	UL listed file E2875
----------------	----------------------

Ordering and shipping details

Category	00106-D & DU SW,NEMA3R, 30-200A
Discount Schedule	DE1A
GTIN	785901461289
Returnability	Yes
Country of origin	US

The information provided in this documentation contains general descriptions and/or technical characteristics of the performance of the products contained herein. This documentation is not intended as a substitute for and is not to be used for determining suitability or reliability of these products for specific user applications. It is the duty of any such user or integrator to perform the appropriate and complete risk analysis, evaluation and testing of the products with respect to the relevant specific application or use thereof. Neither Schneider Electric Industries SAS nor any of its affiliates or subsidiaries shall be responsible or liable for misuse of the information contained herein.

Packing Units

Unit Type of Package 1	PCE
Number of Units in Package 1	1
Package 1 Height	5.20 in (13.208 cm)
Package 1 Width	7.80 in (19.812 cm)
Package 1 Length	16.30 in (41.402 cm)
Package 1 Weight	8.54 lb(US) (3.874 kg)
Unit Type of Package 2	PAL
Number of Units in Package 2	120
Package 2 Height	46.00 in (116.84 cm)
Package 2 Width	40.00 in (101.6 cm)
Package 2 Length	48.00 in (121.92 cm)
Package 2 Weight	1056.00 lb(US) (478.993 kg)

Offer Sustainability

Sustainable offer status	Green Premium product
California proposition 65	WARNING: This product can expose you to chemicals including: Lead and lead compounds, which is known to the State of California to cause cancer and birth defects or other reproductive harm. For more information go to www.P65Warnings.ca.gov
REACH Regulation	REACH Declaration
REACH free of SVHC	Yes
EU RoHS Directive	Compliant EU RoHS Declaration
Mercury free	Yes
China RoHS Regulation	China RoHS Declaration
RoHS exemption information	Yes
Environmental Disclosure	Product Environmental Profile
PVC free	Yes

Contractual warranty

Warranty	18 months
----------	-----------

FLUSH MOUNT

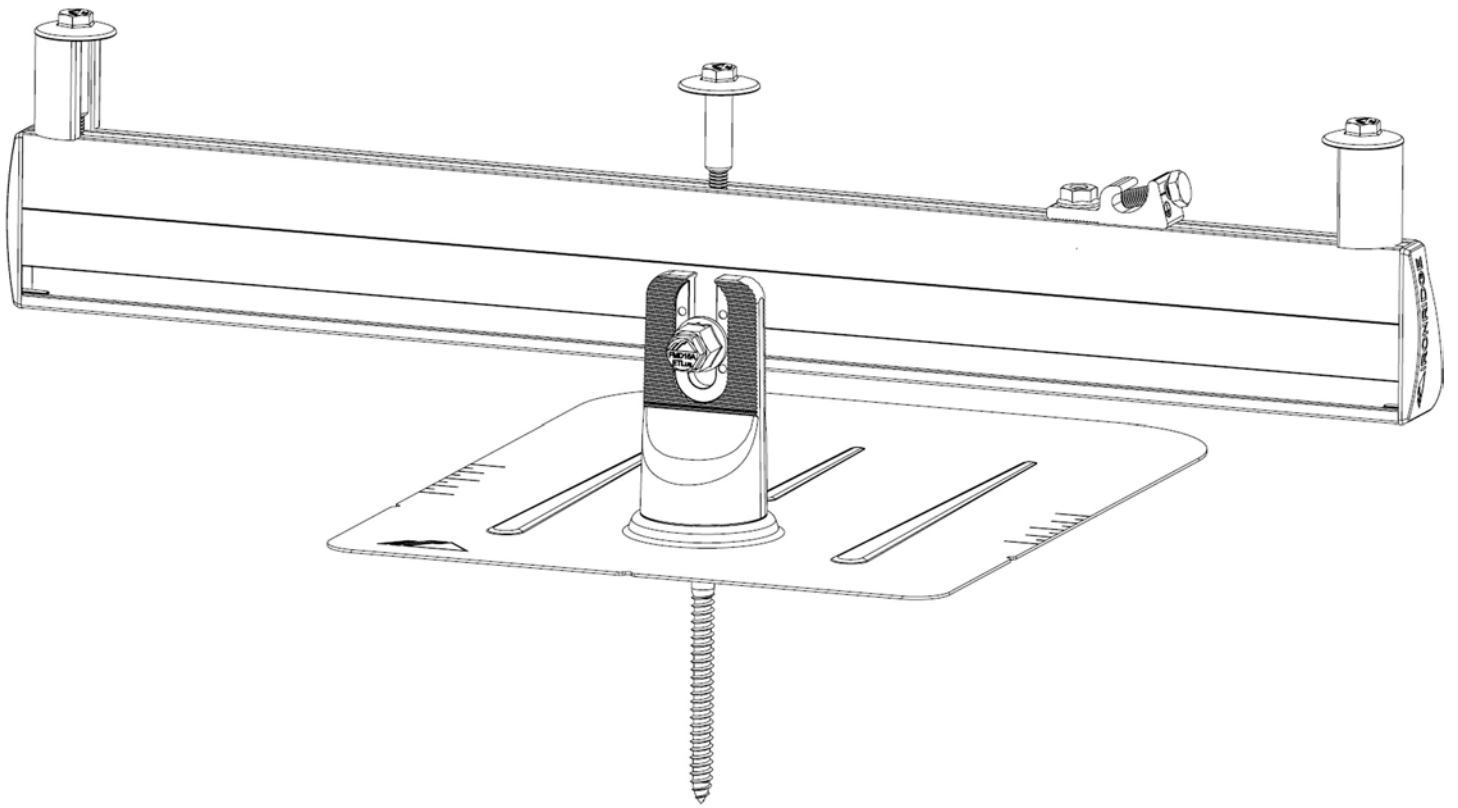

CONTENTS

DISCLAIMER	1
RATINGS	2
MARKINGS	2
ATTACHMENTS	3
COMPONENTS	4
1. ATTACH BASES	5
2. PLACE RAILS	5
3. SECURE LUGS	6
4. SECURE MODULES	6
CAMO	7
BONDING JUMPER	7
EXPANSION JOINTS	8
ELECTRICAL DIAGRAM	9
COMPOSITION SHINGLE	10-11
TILE	12-14
ADDITIONAL ROOF TYPES	14
LOW SLOPE ROOFS	15
CONDUIT PENETRATION	16
CONDUIT MOUNT	17
END CAPS	18
WIRE CLIPS	18
JAYBOX	18
MICROINVERTER KITS	19
SYSTEMS USING ENPHASE MICROINVERTERS OR SUNPOWER AC MODULES	19
SYSTEMS USING MICROSTORAGE PRODUCTS	20
FRAMELESS MODULE KITS	20
CONTOUR	21
MODULE COMPATIBILITY	22-27
FRAMELESS MODULE COMPATABILITY	28

DISCLAIMER

This manual describes proper installation procedures and provides necessary standards required for product reliability. Warranty details are [available on website](#). All installers must thoroughly read this manual and have a clear understanding of the installation procedures prior to installation. Failure to follow these guidelines may result in property damage, bodily injury or even death.

IT IS THE INSTALLER'S RESPONSIBILITY TO:

- Ensure safe installation of all electrical aspects of the array. All electrical installation and procedures should be conducted by a licensed and bonded electrician or solar contractor. Routine maintenance of a module or panel shall not involve breaking or disturbing the bonding path of the system. All work must comply with national, state and local installation procedures, product and safety standards.
- Comply with all applicable local or national building and fire codes, including any that may supersede this manual.
- Ensure all products are appropriate for the installation, environment, and array under the site's loading conditions.
- Use only IronRidge parts or parts recommended by IronRidge; substituting parts may void any applicable warranty.
- Review the [Design Assistant](#) and [Certification Letters](#) to confirm design specifications.
- Ensure provided information is accurate. Issues resulting from inaccurate information are the installer's responsibility.
- Ensure bare copper grounding wire does not contact aluminum and zinc-plated steel components, to prevent risk of galvanic corrosion.
- If loose components or loose fasteners are found during periodic inspection, re-tighten immediately. Any components showing signs of corrosion or damage that compromise safety shall be replaced immediately.
- Provide an appropriate method of direct-to-earth grounding according to the latest edition of the National Electrical Code, including NEC 250: Grounding and Bonding, and NEC 690: Solar Photovoltaic Systems.
- Disconnect AC power before servicing or removing modules, AC modules, microinverters and power optimizers.
- Review module and any 3rd party manufacturer's documentation for compatibility and compliance with warranty terms and conditions.

RATINGS

UL 2703 LISTED



#5003807

Intertek

Conforms to STD UL 2703 Standard for Safety First Edition: Mounting Systems, Mounting Devices, Clamping/Retention Devices, and Ground Lugs for Use with Flat-Plate Photovoltaic Modules and Panels

- Max Overcurrent Protective Device (OCPD) Rating: 40A
- Max Module Size: 30.5 ft²
- Module Orientation: Portrait or Landscape
- System Design Load Rating: 10 PSF downward, 5 PSF upward, 5 PSF lateral
- Actual system structural capacity including spans and cantilevers are defined by PE stamped [certification letters](#).
- CAMO Specific Design Load rating: 50 PSF downward, 50 PSF upward, 15 PSF lateral

Certified to CSA TIL No. A-40 Photovoltaic Module Racking Systems

- Load Rating: 2400 PA [50 PSF]

CLASS A SYSTEM FIRE RATING PER UL 2703

- Any Roof Slope with Module Types 1, 2, 3, 13, 19, 25 & 29: Allowed with any roof slope. Any module-to-roof gap is permitted, with no perimeter guarding required.
- Module Types 4 and 5: Allowed with Steep Slope Roofs ($\geq 9.5^\circ$). Any module-to-roof gap is permitted, low edge guarding (Trim) required
- Class A rated PV systems can be installed on Class A, B, and C roofs without affecting the roof fire rating

CLASS B SYSTEM FIRE RATING PER UL 2703

- Module Types 4 and 5: Allowed with Steep Slope Roofs ($\geq 9.5^\circ$). Any module-to-roof gap is permitted, with no perimeter guarding required

WATER SEAL RATINGS:

- UL 441 (Flashfoot2, All Tile Hook, Knockout Tile, Flashvue, L-Mount)
- TAS 100(A)-95 (Flashfoot2, All Tile Hook, Knockout Tile, Flashvue, L-Mount, Qbase)
- Tested and evaluated without sealant.
- Any roofing manufacturer approved sealant is allowed. Ratings applicable for roof slopes between 2:12 and 12:12

STRUCTURAL CERTIFICATION

- Designed and Certified for Compliance with the International Building Code & ASCE/SEI-7

FLORIDA PRODUCT APPROVAL #FL29843

- Conforms to TAS202, TAS100(A)
- Approved for installation both inside and outside High Velocity Hurricane Zones (HVHZ)
- Allowable design pressure up to +100/-100 PSF
- Additional details and full list of approved components can be found [Here](#).

MARKINGS

Product markings are located on the Grounding Lug bolt head.

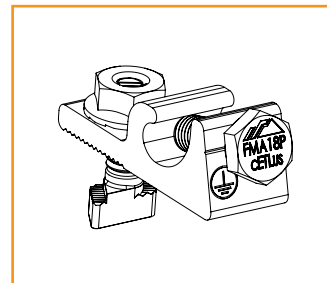
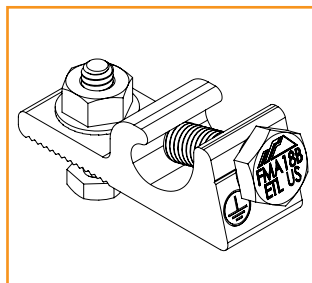

ATTACHMENTS

PRE-INSTALLATION

- ❑ Verify module compatibility. See [Page 21](#) for info.

TOOLS REQUIRED

- ❑ Cordless Drill (non-impact)
- ❑ Impact Driver (for lag bolts)
- ❑ Torque Wrench (0-250 in-lbs)
- ❑ 7/16" Socket
- ❑ 1/2" Socket
- ❑ 9/16" Socket
- ❑ 7/32" Drill Bit
- ❑ 1/8" Drill Bit
- ❑ 1/4" Drill Bit
- ❑ T30 Bit
- ❑ Channel Lock Pliers
- ❑ #3 Phillips Bit
- ❑ 3/16" Hex Bit

BONDING HARDWARE TORQUE VALUES

Please refer to each attachment's individual section for full details on all torque values and instructions.

- ❑ 3/8" Bonding Hardware Nuts (7/16" Socket): 250 in-lbs
- ❑ All Tile Hook Carriage Bolts (7/16" Socket): 132 in-lbs
- ❑ Flat Roof Attachment Nuts (9/16" Socket): 250 in-lbs
- ❑ Lynx Set Screw (3/16" Hex Drive): 150 in-lbs
- ❑ Lynx Flange Nut (1/2" Socket): 150 in-lbs

➤ If using previous version of Integrated Grounding Mid Clamps, End Clamps, Expansion Joints and for a list of approved 3rd party components please refer to Alternate Components Addendum (Version 1.9)

ATTACHMENTS

COMPOSITION SHINGLE



FlashFoot2

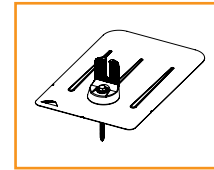

FlashVue

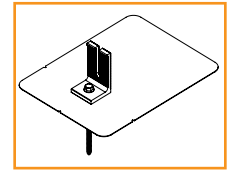

QM L-Mount

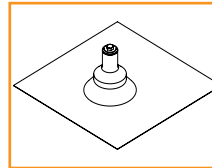

QM QBase

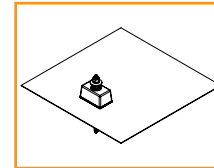

QM Classic Comp Mount

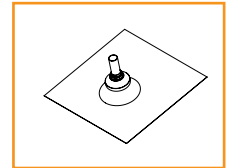

QM Composition Conduit Penetration

TILE

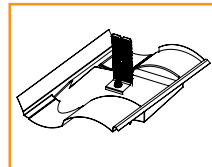

Knockout Tile

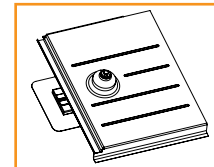

QM Tile Replacement

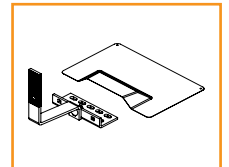

All Tile Hook and Flashing (optional)

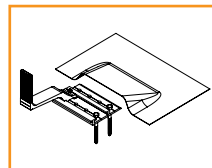

QM Quick Hook and Flashing (optional)

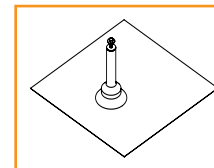

QM QBase Tile

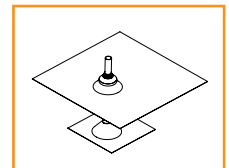

QM Tile Conduit Penetration

ADDITIONAL ROOF TYPES

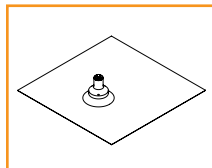

QM Qbase Shake - Slate - Metal Shingle

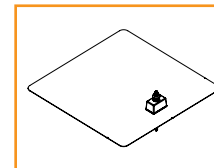

QM Classic Mount Shake

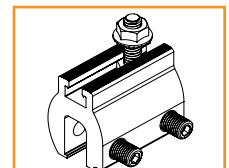

QM Lynx Metal Roof Attachment

LOW SLOPE ROOF

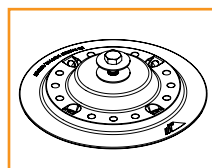

Flat Roof Attachment

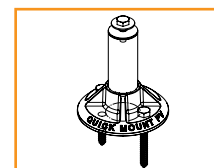

QM QBase Mount

COMPONENTS

PRE-INSTALLATION

- Verify module compatibility. See [Page 21](#) for info.

TOOLS REQUIRED

- Cordless Drill (non-impact)
- Impact Driver (for lag bolts)
- Torque Wrench (0-250 in-lbs)
- 7/16" Socket
- 1/2" Socket
- 9/16" Socket
- 7/32" Drill bit
- 1/8" Drill bit
- 1/4" Drill bit
- T30 Torx Bit
- Channel Lock Pliers
- #3 Phillips Bit
- Paddle Bit

BONDING HARDWARE TORQUE VALUES

Please refer to each attachment's individual section for full details on all torque values and instructions.

- Universal Fastening Object (7/16" Socket): 80 in-lbs
- Rail Grounding Lug Nut (7/16" Socket): 80 in-lbs
- Module Grounding Lug Nut (7/16" Socket): 60 in-lbs
 - Grounding Lug Terminal Screws (7/16" Socket): 20 in-lbs
- Expansion Joint Nuts (7/16" Socket): 80 in-lbs
- Microinverter Kit Nuts (7/16" Socket): 80 in-lbs
- Frameless Module Kit Nuts (7/16" Socket): 80 in-lbs
- 3/8" Bonding Hardware Nuts (7/16" Socket): 250 in-lbs
- Contour Clamp (T-30 Torx Bit): 80 in-lbs

► Unless otherwise noted, all components have been evaluated for multiple use. They can be uninstalled and reinstalled in the same or new location.

COMPONENTS

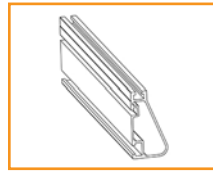

XR Rail



Wire Clip

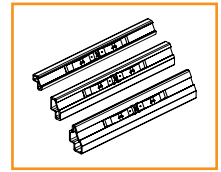

BOSS

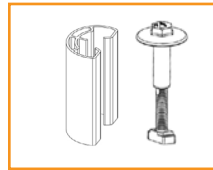

UFO and Stopper Sleeve (30-46MM)



CAMO

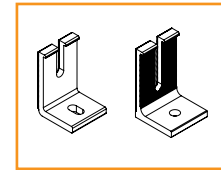

Ironridge L-Foot and QM L-Foot



End Cap



Rail Grounding Lug

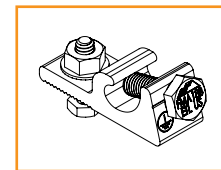

Module Grounding Lug

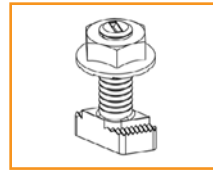

Microinverter Kit

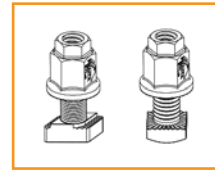

3/8" Bonding Hardware

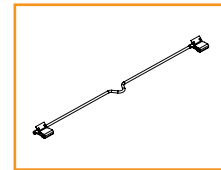

8" Bonding Jumper Single Use Only

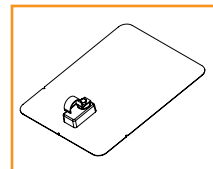

QM Classic Conduit Comp Mount

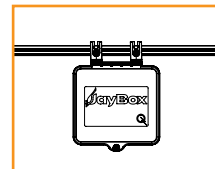

JAYBOX

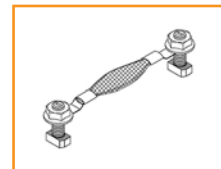

Expansion Joint

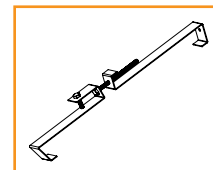

QM Tile Conduit Mount



Frameless End/Mid Clamp

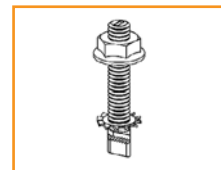

Frameless Module Kit

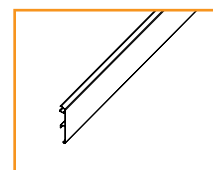

Contour Trim

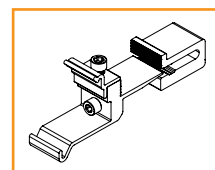

Contour Clamp

1. PLACE ATTACHMENTS

The general installation method for attachments is to locate a rafter, drill a pilot hole and install the attachment. For composition roof attachments installation instructions refer to [page 10](#). For tile roof attachments refer to [page 12](#). For low slope roof attachments refer to [page 14](#). When using approved third party attachments, refer to manufacturer's install instructions.

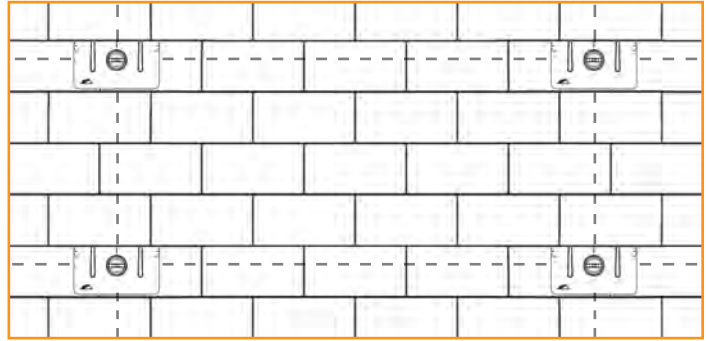

Tested or evaluated third-party roof attachments:

- [S-5! Standing Seam Metal Roof Clamps](#) - Certification of metal roof clamps includes bonding to both painted and galvalume metal roofs. Tighten S-5! and S-5! Mini set screws to 130-150 in-lbs (≥ 24 gauge) or 160-180 in-lbs (22 gauge) roofs. Tighten S-5! M10 bolt to 240 in-lbs or S-5! Mini M8 bolt to 160 in-lbs. Use the following fastening guidelines for other S-5! roof clamps: ProteaBracket™ - firmly seat roof screws and tighten hinge bolt to 225 in-lbs; RibBracket™ - firmly seat roof screws and tighten M8 bolt (M8-1.25 x 22mm sold separately) to 160 in-lbs; and SolarFoot™ - firmly seat roof screws and tighten M8 flange nut to 160 in-lbs.
- [EcoFasten Green Fasten GF-1 Anchors](#)

2. PLACE RAILS

A. CONNECT SPLICES

Use BOSS (Bonded Structural Splice), as needed, to join multiple sections of Rail.

BOSS - Bonded Structural Splice

Insert BOSS into first Rail up until the Stop Tab. Slide second Rail fully into place.

- Rows using BOSS and exceeding 100 feet of Rail must use [Expansion Joints](#).
- Boss Splices may be installed in any location within a span.
- UFO and Bonding Hardware must be installed 1" away from the point where two Rails join together.

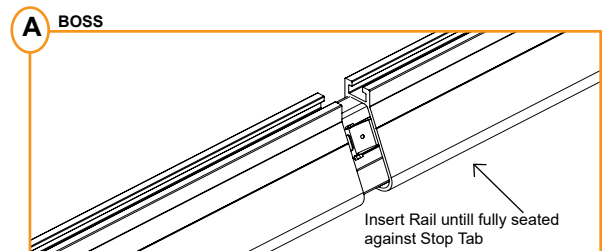

B. PREPARE HARDWARE

Slide square-headed bolts into side-facing rail slot. Space out bolts to match attachment spacing.

- Tape ends of rail, to keep bolts from sliding out while moving.
- If using T-bolts, carry hardware onto roof and proceed.

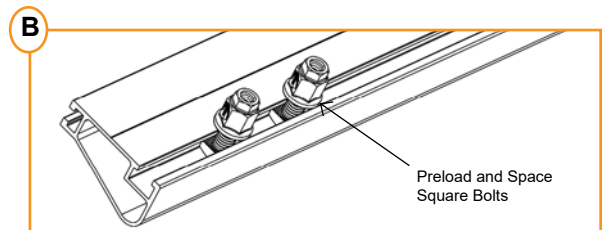

C. ATTACH RAILS

Drop rail with hardware into roof attachment. Level rail at desired height, then torque to 250 in-lbs.

- Rail can face either upslope or downslope on roof.
- When using attachments with longer slots, do not install Rail lower than the top of the L-Foot to avoid damage to modules.

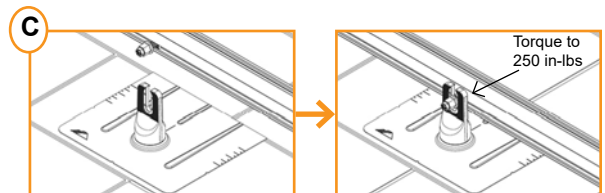

3. SECURE LUGS

Grounding Lugs

Only one Grounding Lug (Rail or Module) required per continuous subarray, regardless of subarray size (Unless frameless modules are used, see [Page 20](#)).

- **Grounding Lugs are intended to for use with one solid or stranded copper wire, conductor size 10-4 AWG.**

Rail Grounding Lug

Insert T-bolt in Top Rail slot and torque Hex Nut to **80 in-lbs**. Install a minimum 10 AWG solid copper or stranded grounding wire. Torque terminal screw to **20 in-lbs**.

- **Module Grounding Lugs can be installed anywhere along the Rail and in either orientation shown.**

Module Grounding Lug

Insert Bolt through Manufacturer approved grounding location and torque Hex nut to **60 in-lbs**. One Module Grounding Lug may be installed to one module per row. Install a minimum 10 AWG solid copper or stranded grounding wire. Torque terminal screw to **20 in-lbs**.

- **If using Enphase microinverters or Sunpower AC modules, Grounding Lugs may not be needed. See [Page 19](#) for more info.**
- **Refer to module manufacturer for mounting location and instructions.**

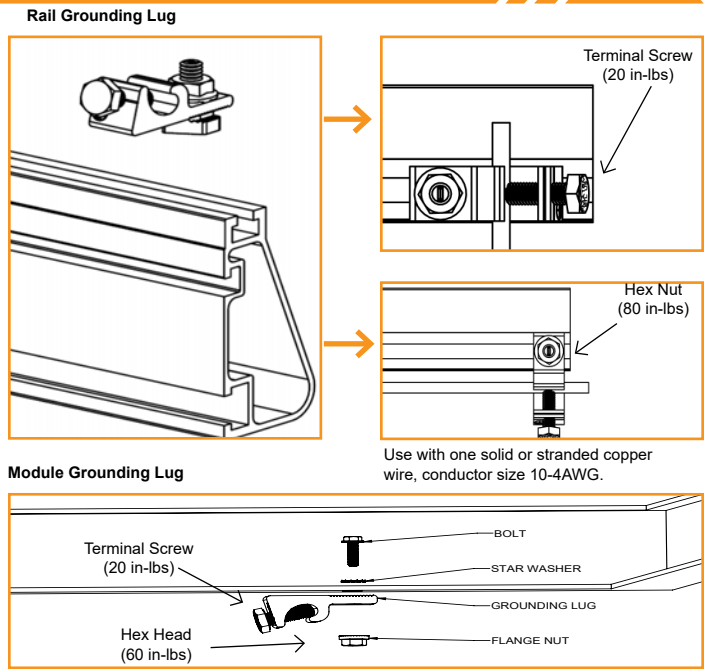

4. SECURE MODULES

A. SECURE FIRST END

Place first module in position on rails, a minimum of 1" from rail ends. Snap Stopper Sleeves onto UFO. Fasten module to rail using the UFO, ensuring that the UFO is hooked over the top of the module. Torque to **80 in-lbs**.

- **Ensure rails are square before placing modules.**
- **Hold Stopper Sleeves on end while torquing to prevent rotation.**
- **If using CAMO instead of UFO + Stopper Sleeve, refer to [Page 19](#) for CAMO installation procedure.**
- **UFO can be installed on modules 30 to 46mm.**

B. SECURE NEXT MODULES

Place UFO into each rail, placing them flush against first module. Slide second module against UFO. Torque to **80 in-lbs**. Repeat for each following module.

- **When reinstalling UFO, move modules a minimum of 1/16" so UFOs are in contact with a new section of module frame.**
- **When UFOs are loosened and re-tightened, ensure UFO T-bolt bottoms out in rail channel before re-torquing UFO to achieve full engagement between T-bolt and rail.**
- **If using Wire Clips, refer to [Page 18](#).**

C. SECURE LAST END

Place last module in position on rails, a minimum of 1" from rail ends. Snap Stopper Sleeves onto UFO. Secure UFO Clamps on rails, ensuring they are hooked over top of module. Torque to **80 in-lbs**.

- **Hold Stopper Sleeves on end while torquing to prevent rotation.**
- **Repeat all steps for each following row of modules, leaving a minimum 3/8" gap between rows**
- **If using CAMO instead of UFO + Stopper Sleeve, refer to [Page 6](#)**

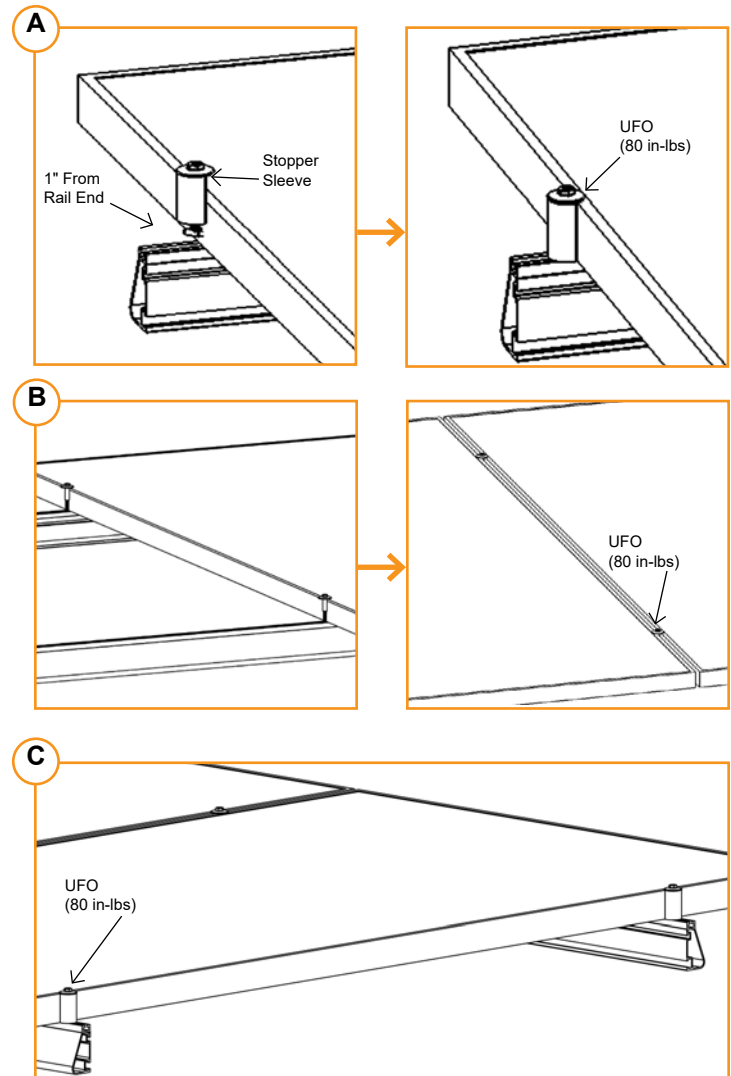

CAMO

A. SLIDE INTO RAIL

Slide CAMO into rail channel far enough to clear the module frame. CAMO requires 6" of clearance from end of rail.



B. PLACE MODULE

Place module on rails (module cells not shown for clarity). When installing CAMO the module can overhang the rail no more than 1/4".

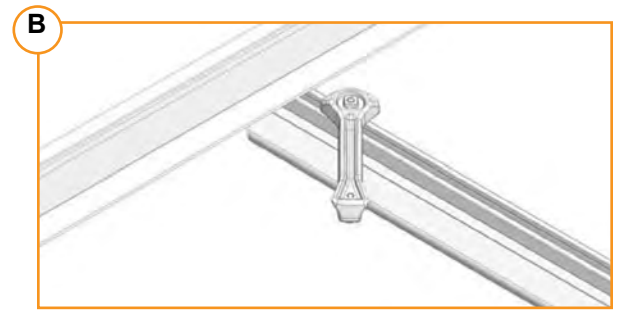

C. PULL TOWARDS END

Pull CAMO towards rail ends, at 45 degree angle, so the bonding bolt contacts the module flange edge.

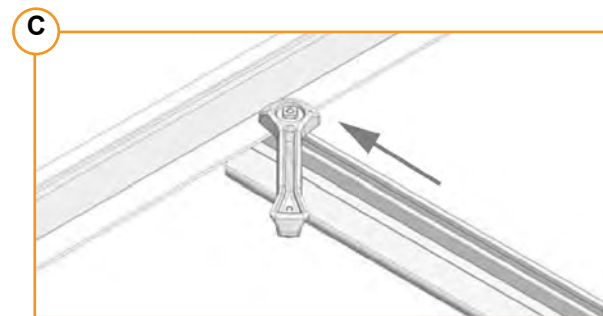

D. SECURE TO FRAME

Rotate handle with an upwards motion until CAMO snaps into rail channel. Ensure CAMO bonding pins are fully seated on top of module frame.

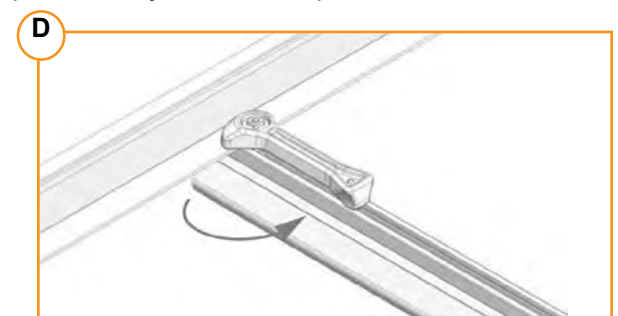

FRAME COMPATIBILITY

CAMO has been tested or evaluated with all modules listed in the Module Compatibility section having frames within the referenced dimensions. Be sure the specific module being used meets the dimension requirements.

- For installations with Hanwha Q CELLS modules with 32 mm frame heights, the maximum ground snow is 45 PSF (33 PSF module pressure).
- CAMO is only compatible with Canadian Solar modules CS1YxxxMS and CS3N-xxxMS. "xxx" refers to the module power rating

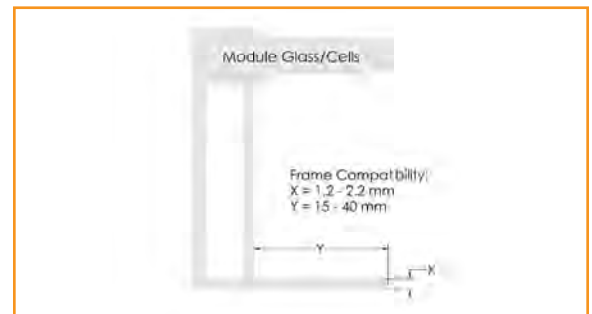

8" BONDING JUMPER

8" Bonding Jumper is an electrical bonding jumper that can be used on the Flush Mount System for row to row bonding; making the module frames the medium for the equipment ground path.

- Bonding jumper is pushed onto the bottom flange of the module.
- New jumpers should be used if re-installation of jumper is required.
- Supports bottom flange thicknesses from 1.2mm to 3.1mm.



EXPANSION JOINTS

Expansion Joints are required every 100' of continuous rail to allow for thermal expansion and contraction of the system.

➤ Do not install modules over expansion joint.

BOSS

Insert BOSS into first Rail up to the Alignment Circle, Slide second Rail over BOSS to the second Alignment Circle, leaving a 1" gap between the Rails.

There must be a 1" of space between the edge of the Rail and the edge of the panel to allow proper installation of the UFO and Stopper Sleeve.

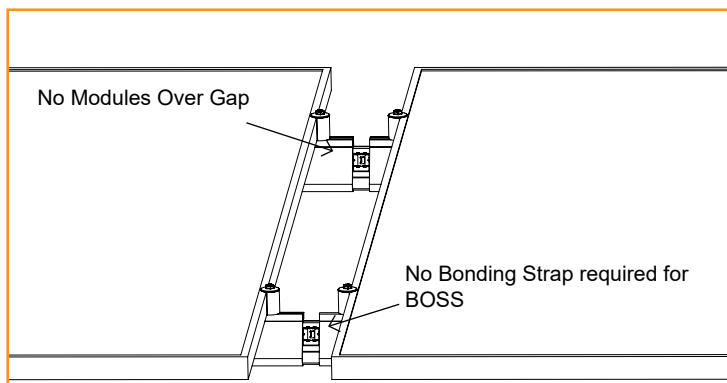
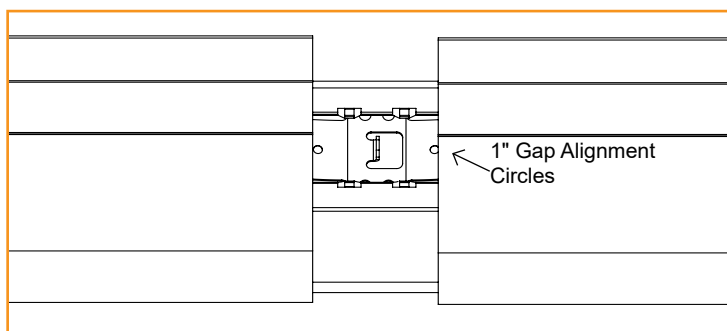
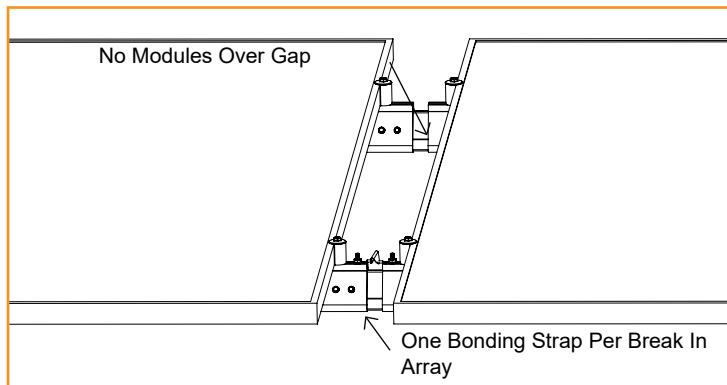

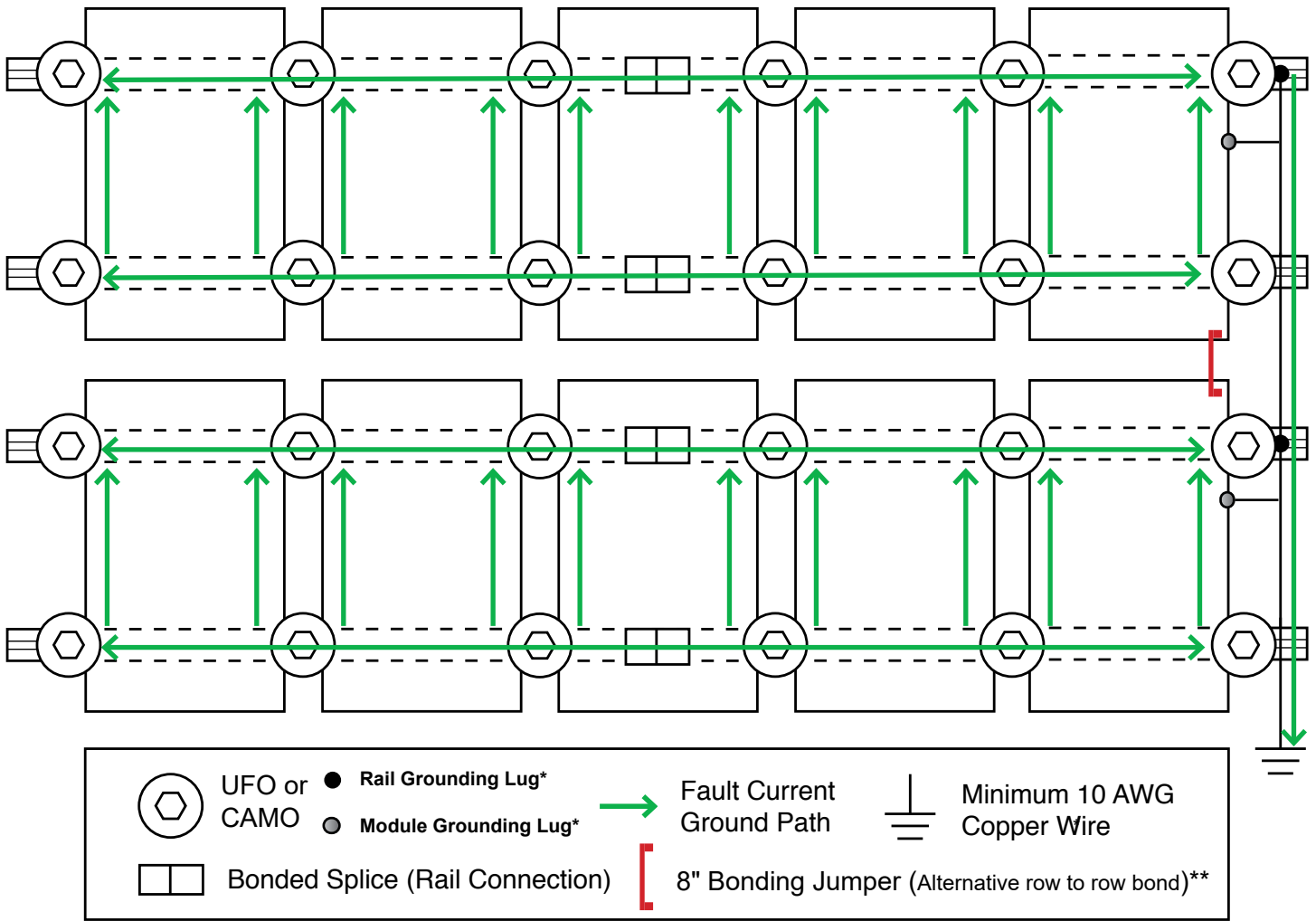

*One Module Grounding Lug or Rail Grounding lug is required per row of a system.

** The use of the 8" Bonding Jumper eliminates the need for row to row bonding. A minimum of one grounding lug per continuous array is required for earth ground.

Grounding Lugs and wire are not required in systems using certain Enphase microinverters or certain Sunpower modules. Equipment grounding is achieved with the Engage cable for Enphase or the AC module cable system for Sunpower via their integrated EGC.

FLASHFOOT2

Locate roof rafters and mark locations on roof. Drill 1/4" pilot holes perpendicular to the roof and back fill with roofing manufacturers' approved sealant. Slide flashing between 1st and 2nd course of shingles, ensuring both that the flashing reaches under the 3rd shingle course and doesn't overhang the downhill shingle course. Line up with pilot hole and insert supplied lag bolt with washer through flashing. With a 7/16" Socket fully seat lag bolt. Place Cap onto flashing in desired orientation for E/W or N/S rails and rotate 180 degrees until it locks into place.

- Rail can be installed on either side of FlashFoot2 Cap.
- For additional details refer to the full FlashFoot2 [Installation Manual](#).

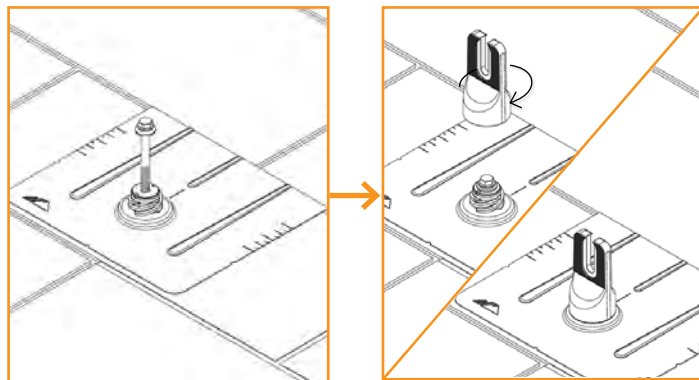

FLASHVUE

Locate rafters and snap vertical and horizontal lines to mark locations of flashings. Drill 1/4" pilot holes, then backfill with an approved sealant. Slide flashing between 1st and 2nd course of shingles, ensuring both that the flashing reaches under the 3rd shingle course and doesn't overhang the downhill shingle course. Line up pilot hole with View Port. Press Grip Cap onto flashing in desired orientation for E/W or N/S rails. Insert Lag Bolt with mechanically bonded washer through flashing. With a 7/16" Socket drive Lag Bolt until fully seated. FlashVue is now installed and ready for IronRidge XR Rails. Attach rails to either side of the open slot using bonding hardware. Level rail at desired height, then torque to **250 in-lbs (21 ft-lbs)**.

When installing GripCap+ on roofs with undulations greater than 1 inch, install GripCap+ in low points across the array as required.

- For additional details refer to the full FlashVue [Installation Manual](#).
- For additional details on the GripCap+ refer to the full GripCap+ [Installation Manual](#).

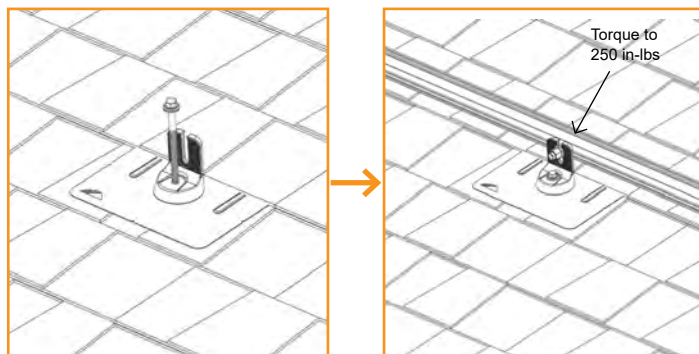

COMPOSITION SHINGLE

QM L-MOUNT

Locate roof rafters and mark locations on roof. Drill 7/32" (Lag) or 1/8" (ST) pilot holes perpendicular to the roof and back fill with roofing manufacturers' approved sealant. Slide flashing between 1st and 2nd course of shingles, ensuring both that the flashing reaches under the 3rd shingle course and doesn't overhang the downhill shingle course. Place L-foot on flute and rotate into desired position. Prepare lag bolt or structural screw with sealing washer. Use 1/2" socket to drive prepared lag bolt through L-foot until fully seated and L-foot can no longer rotate easily. Torque Nut to **156 in-lbs (13 ft-lbs)** for ST. Attach rail to L-Foot with Bonding Hardware and torque to **250 in-lbs (21 ft-lbs)**.

- Structural screw can be driven with T-30 hex head bit.
- For additional details refer to the full QM [Installation Manual](#).

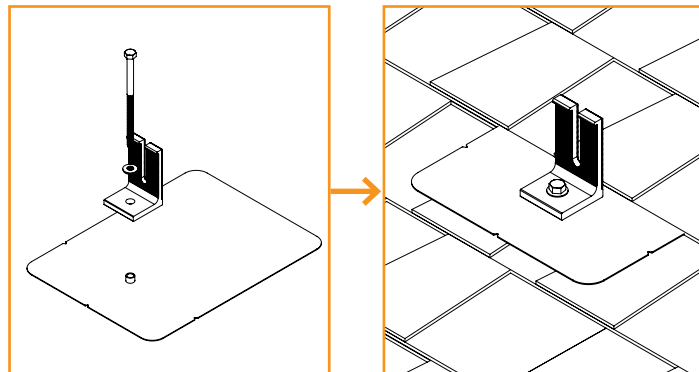

QM QBASE COMPOSITION MOUNT

Locate roof rafters and mark locations on roof. Align QBase vertical holes over center rafter and mark. Drill two pilot holes with 7/32" drill bit, perpendicular to roof and back fill with roofing manufacturers' approved sealant. Set grade 8 cap screw through bottom of QBase, place QBase over drilled holes and secure lags. Screw Post to QBase. Proceed with roofing up until the flashing should be installed. Install flashing over mount. Allow roofing to proceed to the next course. Apply sealant where post and flashing meet, install EPDM counter flashing collar. Attach L-Foot on Standoff with hardware. Torque to **174 in-lbs (14.5 ft-lbs)**. Attach rail to L-Foot with Bonding Hardware and torque to **250 in-lbs (21 ft-lbs)**.

- For additional details refer to the full QM [Installation Manual](#).

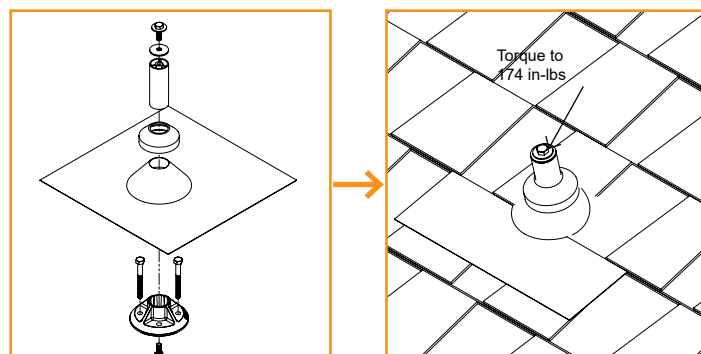

CLASSIC COMP MOUNT

Locate roof rafters and mark locations on roof. Drill 7/32" pilot holes perpendicular to the roof and back fill with roofing manufacturers' approved sealant. Slide flashing between 1st and 2nd course of shingles, ensuring both that the flashing reaches under the 3rd shingle course and doesn't overhang the downhill shingle course. Prepare Hanger Bolt with Hex Nut and Sealing Washer, insert into hole and using 1/2" socket drive hanger bolt until fully seated and QBlock stops rotating easily. Insert EPDM rubber washer over hanger bolt into block, using Rack Kit hardware secure L-Foot to the mount. Torque to **156 in-lbs (13 ft-lbs)**. Attach rail to L-Foot with Bonding Hardware and torque to **250 in-lbs (21 ft-lbs)**.

- For additional details refer to the full QM [Installation Manual](#).

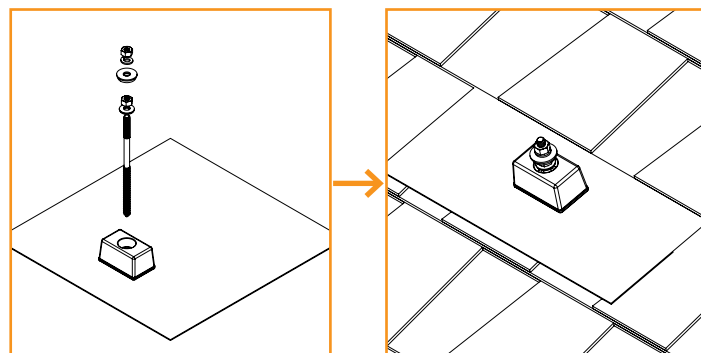

TILE

KNOCKOUT TILE

Remove tile and mark rafter. Use base as guide to drill 1/4" pilot hole and fill with roofing manufacturer's approved sealant. Install optional Roof Flashing and seal appropriately. Insert lag bolt with bonded washer through base (and flashing if used) and drive until fully seated. Insert Tile Replacement Flashing, lower onto base and apply pressure over the threaded post until it dimples the flashing. Place L-Foot over dimple and tap with hammer to punch threaded post through the flashing. Ensure punched pieces of flashing are cleared away. Form flashing as needed to sit flush with surrounding tiles, position L-Foot in desired orientation and torque hardware to **132 in-lbs (11 ft-lbs)**. Attach rail to L-Foot with Aire Dock and torque to **250 in-lbs (21 ft-lbs)**.

- Base can be installed in any orientation relative to rafter.
- Ensure L-Foot does not extend above rail.
- Optional deck level flashing is available. Standalone [installation manual](#) available on website
- Standalone [Knockout Tile manual](#) available on website.

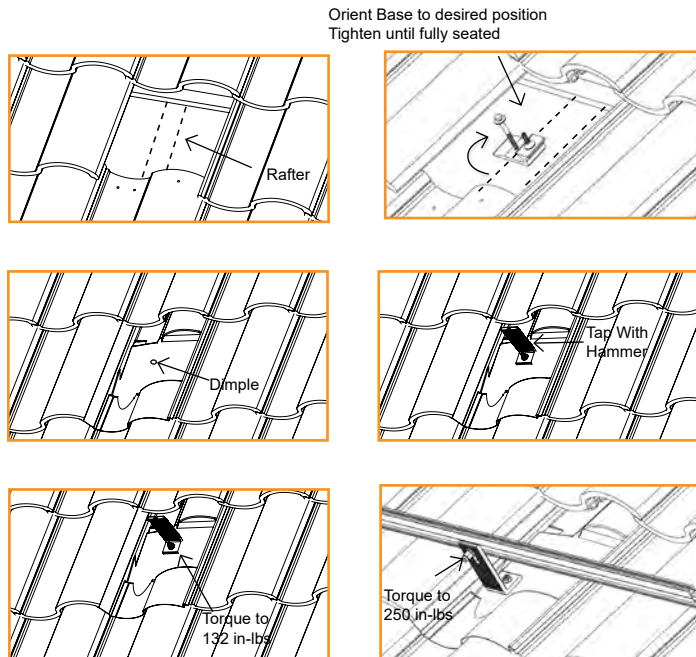

QM TILE REPLACEMENT

Remove tile and mark rafter. Measure up 8 3/4" from the adjacent tiles and mark horizontal across rafter. Align baseplate over rafter so that the lag holes align with the post groove. The orientation of the plate can be adjusted cross roof, mark location of lag holes on the roof. Drill two 1/8" Pilot holes and back fill with roofing manufacturers' approved sealant. Waterproof at underlayment level according to roofing manufacturers' instructions and the Tile Roofing Industry Alliance guidelines. Use T-30 Torx bit to lag base into position. Insert Grade 8 Serrated Flange Bolt into bottom of the Post, slide Post into Base channel. Line up post with the hole in the Tile Replacement Flashing. Leave loose for adjustments. Place Tile Replacement Flashing over the Post and Mount, allowing the flashing to properly interlock with surrounding tiles. Secure Post by tightening with channel lock pliers. Replace all tiles. Apply a bead of sealant where the post meets the flashing, slip EPDM collar over post and down to flashing. Attach L-Foot on Standoff with hardware. Torque to **174 in-lbs (14.5 ft-lbs)**. Attach rail to L-Foot with Bonding Hardware and torque to **250 in-lbs (21 ft-lbs)**.

- If deck level flashing is required, approved flashing methods include user supplied adhesive backed flexible flashing.
- For additional details refer to the full QM [Installation Manual](#).

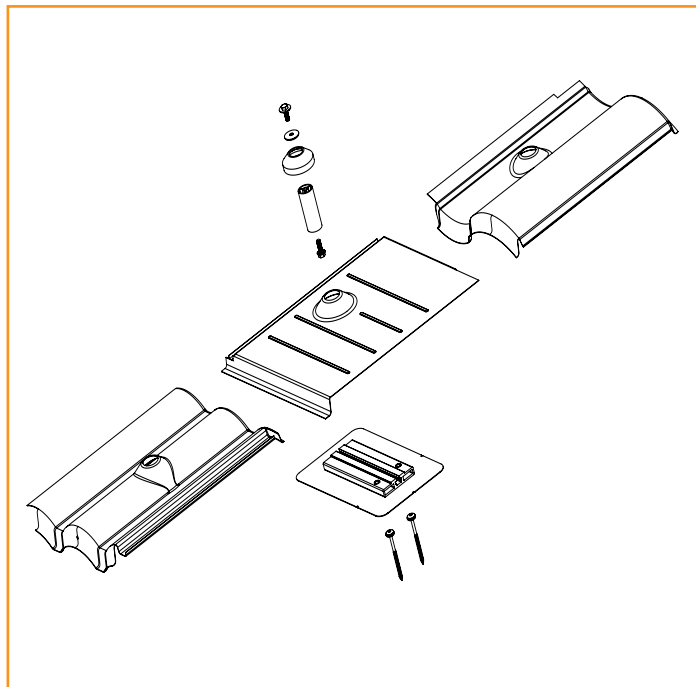

ALL TILE HOOK

Remove tile and mark rafter. Position base over rafter, adjust arm if necessary and torque hardware to **132 in-lbs (11 ft-lbs)**. Use base as guide to drill 1/4" pilot holes, back fill with roofing manufacturer's approved sealant, then insert lag bolts and tighten until fully seated. Replace tiles and notch as necessary to ensure proper fit. Attach rails to either side of slot using Bonding Hardware and torque to **250 in-lbs (21-ft-lbs)**.

- Position arm near the center of valley for curved tiles.
- Position arm away from seam of joining flat tiles.
- Ensure top of hook does not extend above rail.
- Standalone [All Tile Hook manual](#) available on website.

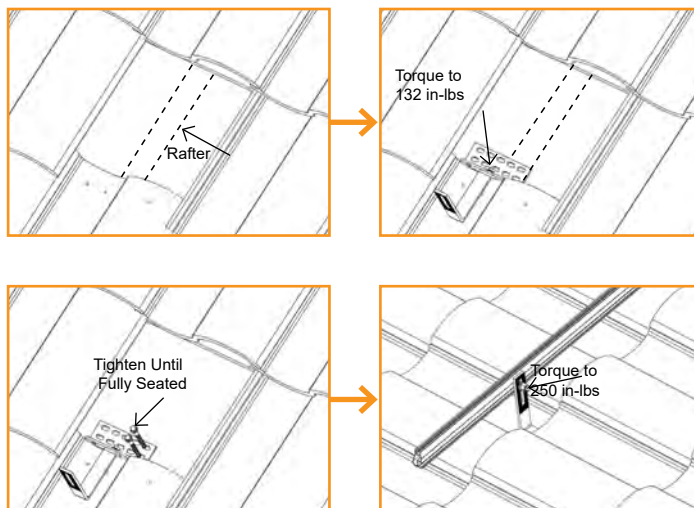

QM QUICK HOOK

Remove tile and mark rafter, use Base Plate to mark two holes on rafter. Drill two 7/32" pilot holes and back fill with roofing manufacturers' approved sealant. Use 1/2" socket to drive lag into place. Slide hook into place and adjust to desired position. Drive self-tapping screw using a #3 Phillips bit to lock hook in place. Clean underlayment and apply a bead of sealant compatible with roofing manufacturer, install flashing over mount. Fasten sub-flashing to deck with one roofing nail in each corner. Waterproof at underlayment level according to roofing manufacturers' instructions and the Tile Roofing Industry Alliance guidelines. Cut clearance notch in the weather guard of tile as needed or utilize QM Tile Replacement Flashings. Attach rails to either side of slot using Bonding Hardware and torque to **250 in-lbs (21-ft-lbs)**.

- Position arm near the center of valley for curved tiles.
- Position arm away from seam of joining flat tiles.
- Ensure top of hook does not extend above rail.
- For additional details refer to the full QM [Installation Manual](#).

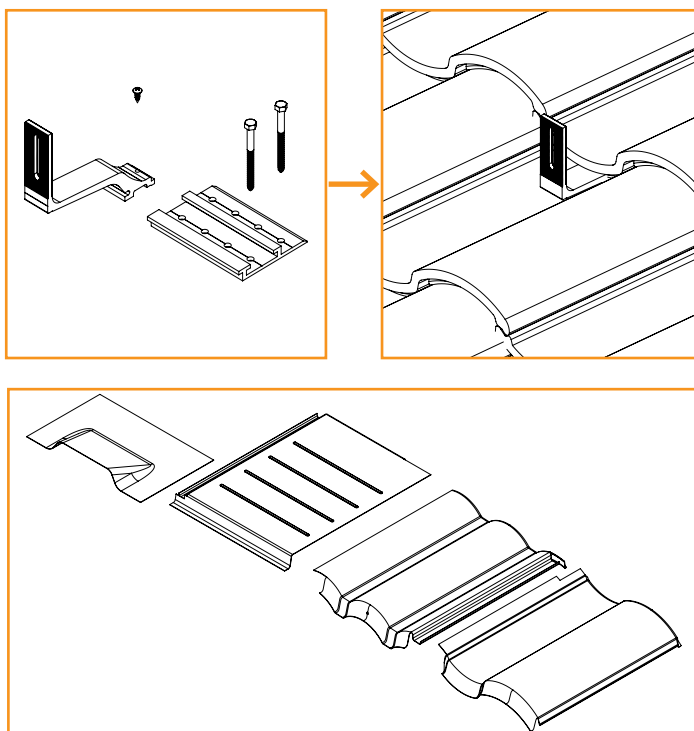

TILE

QM QBASE UNIVERSAL TILE MOUNT

Remove tile and mark rafter. Measure up 6 5/8" from bottom of tiles and mark horizontally. Align QBase over rafter center and drill two 7/32" pilot holes, back fill with roofing manufacturers' approved sealant. Place grade-8 Cap Screw under QBase, lag QBase into rafter location. Install Sub-flashing, waterproof at underlayment level according to roofing manufacturers' instructions and the Tile Roofing Industry Alliance guidelines. Cut tile with diamond blade to allow post to pass through. Place tile in position and then install Post. Install 18"x18" flashing, pre-bent to follow the contour of the tile as required. Apply sealant where Post and Flashing meet and install EPDM counter flashing. Attach L-Foot on Standoff with hardware. Torque to **174 in-lbs (14.5 ft-lbs)**. Attach rails to L-Foot using Bonding Hardware and torque to **250 in-lbs (21-ft-lbs)**.

➤ For additional details refer to the full QM [Installation Manual](#).

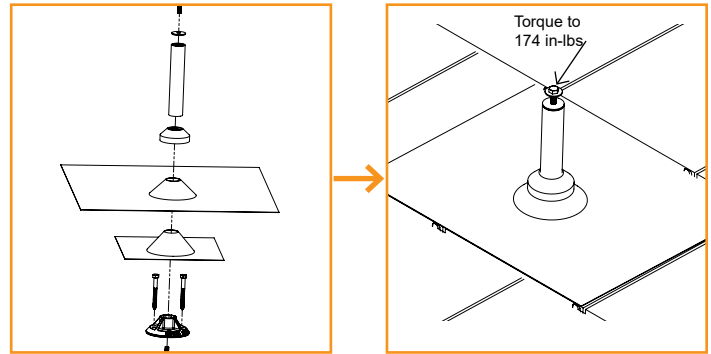

ADDITIONAL ROOF TYPES

QM CLASSIC SHAKE MOUNT

Locate roof rafters and mark locations on roof, remove shakes directly above mount if needed to expose felt paper. Level out installation area and location installation point, mark. Drill 7/32" pilot hole, back fill with roofing manufacturers' approved sealant. Prepare Hanger Bolt with Hex Nut and Sealing washer, insert into QBlock hole and drive into rafter until fully seated and the QBlock no longer swivels easily. Insert EPDM washer over hanger bolt and then install L-Foot in desired orientation and torque hardware to **132 in-lbs (11 ft-lbs)**. Attach rail to L-Foot with Bonding Hardware and torque to **250 in-lbs (21 ft-lbs)**.

➤ For additional details refer to the full QM [Installation Manual](#).

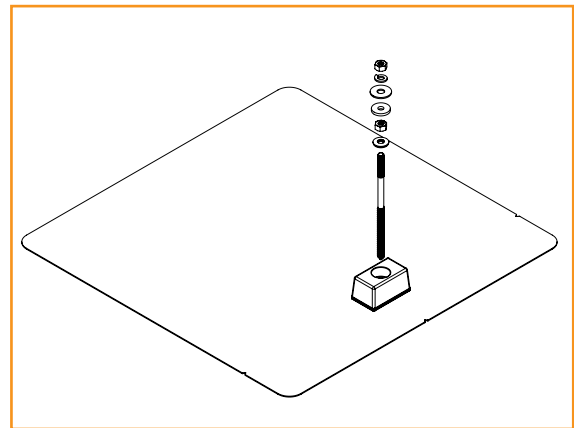

QM QBASE METAL, SHAKE AND SLATE

The QM QBase can be used to install on multiple roofing types with different installation methods.

➤ For instructions on installing the QBase on Slate refer to the full QM [Installation Manual](#).

➤ For instructions on installing the QBase on Shake refer to the full QM [Installation Manual](#).

➤ For instructions on installing the QBase on Metal Shingle refer to the full QM [Installation Manual](#).

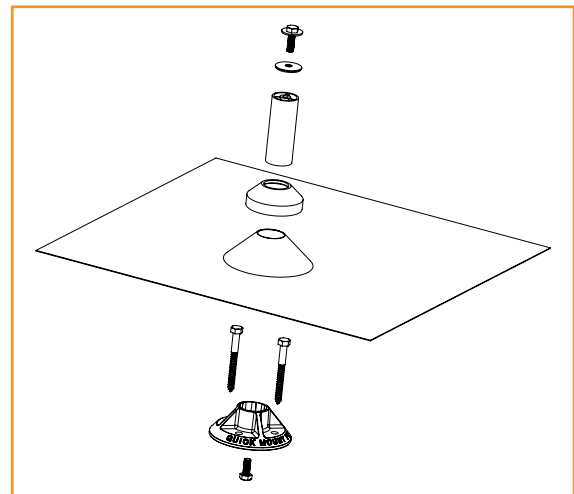

LOW SLOPE ROOFS

FLAT ROOF ATTACHMENT

Flat Roof Attachment can be used with an L-foot for flush mounting modules on low sloped roofs. Mark locations for Flat Roof Attachment. Screws should be installed symmetrically to each other. If using a membrane flashing, remove the silicone washer's protective liner prior to attaching the membrane. Attach L-foot with washers and 3/8" hardware torqued to **250 in-lbs (21 ft-lbs)**. Seal attachment and/or membrane per roofing manufacturer's requirements.

- **Type, size, and quantity of roof screws to be specified by Structural Engineer. Fastener size not to exceed #15.**
- **Membrane flashing available for TPO, PVC, and KEE roofs. Ensure membrane flashing is compatible with existing roofing material.**
- **If membrane flashing is not used, only washer on top of L-Foot is required.**
- Standalone [Flat Roof Attachment Manual](#) available on website.

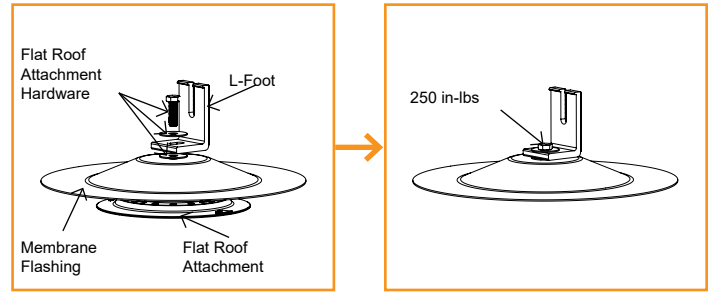

QM QBASE MOUNT

Locate the desired mount placement over a rafter. Using the base as a template, mark the two penetration points. Drill two 7/32" pilot holes, back fill with roofing manufacturers' approved sealant. Place the grade-8 hex bolt in the bottom of the base and screw the Post. Attach L-Foot on Standoff with hardware. Torque to **174 in-lbs (14.5 ft-lbs)**. Attach rail to L-Foot with Bonding Hardware and torque to **250 in-lbs (21 ft-lbs)**.

The mount can be flashed with available 9", 12" or 18" aluminum flashings, pitch pocket or curb, or with a membrane cone flashing. If using a membrane flashing utilize the services of a qualified roofer

- For additional details refer to the full QM [Installation Manual](#).

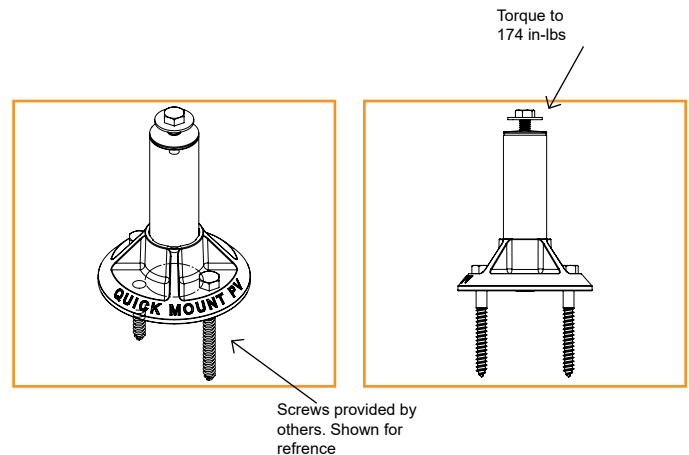

METAL ROOF

QM LYNX

Locate the desired mount placement over a roofing seam, make sure block is fully seated on metal seam. Torque Set Screws to **150 in-lbs(12.5 ft-lbs)** using 3/16" Hex Drive, alternate driving each bolt till required torque is met. Slide Hex Bolt into slot and to desired position. Place rail attachment bracket over Hex Bolt and secure with Flange Nut, torque Flange Nut to **150 in-lbs(12.5 ft-lbs)** using 1/2" socket.

- For additional details refer to the full QM [Installation Manual](#).
- Certification of Lynx calmp includes bonding to both painted and galvalume metal roofs.

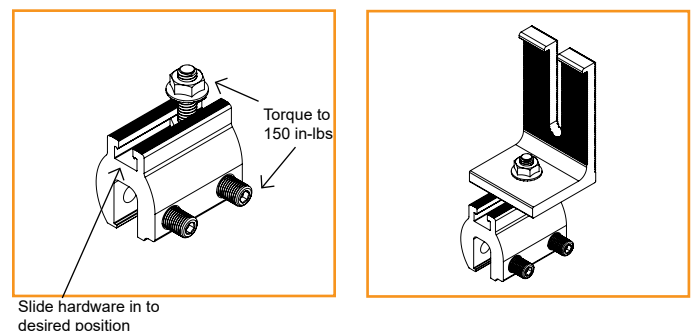

CONDUIT PENETRATION FLASHINGS

QM CONDUIT PENETRATION FLASHING - COMP SHINGLE

Mark a drill point so that the flashing reaches up to the 3rd shingle course. Drill your conduit hole next to the rafter so you can secure the conduit below the roof surface. Cut shingle and remove nails as needed to center the drilled hole and flashing hole. Apply roofing manufacturer's approved sealant on the underside of the flashing in a Upside down U and to top of flashing. Under the 3rd course and through the second course secure flashing with 2 roofing nails, apply sealant over the nail heads. Cut EPDM collar to appropriate size. Apply a bead of sealant compatible with the roofing manufacturer and EPDM rubber to anywhere the EPDM collar contacts.

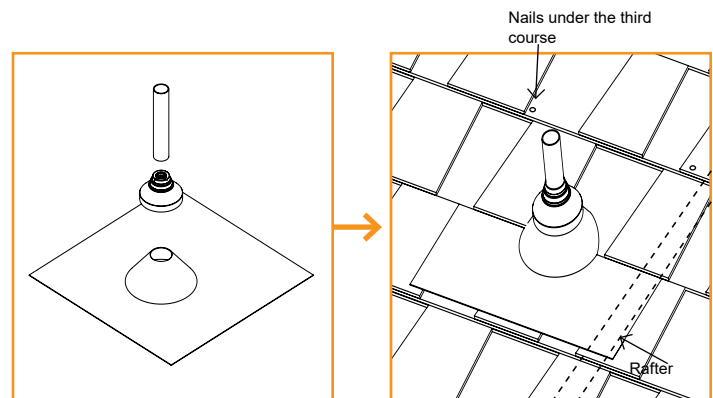

- Be sure to secure conduit to rafters below the roof surface per local building codes and NEC code requirements.
- Cut EPDM collar to appropriate size using the sizing chart in the installation manual, approved for 1/2" to 1" EMT.
- For additional details refer to the full QM [Installation Manual](#).

QM CONDUIT PENETRATION FLASHING - TILE

Drill your conduit hole next to the rafter so that you can secure the conduit below the roof surface. Apply roofing manufacturer approved sealant to the underside of the sub-flashing in the shape of an upside down U. Clear away any dust and debris to install sub-flashing. Waterproof at under laminate level according to roofing manufacturer instructions and Tile Roofing Institute Guidelines. Under the top layer of felt, secure the sub-flashing with two roofing nails. Cut EPDM collar to appropriate size. Apply a bead of sealant compatible with the roofing manufacturer and EPDM rubber to anywhere the EPDM collar contacts. With a diamond blade cut tile to allow conduit to pass through, replace all tiles. Bend the flashing to follow the contour of the tiles. Place flashing over the conduit and tuck up under the next course of tiles. Apply a bead of sealant compatible with the roofing manufacturer and EPDM rubber to anywhere the EPDM collar contacts. Slide collar onto conduit all the way down to the flashing.

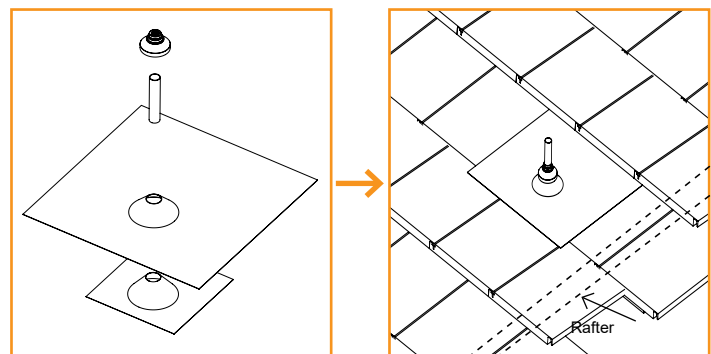

- Be sure to secure conduit to rafters below the roof surface per local building codes and NEC code requirements.
- Cut EPDM collar to appropriate size using the sizing chart in the installation manual, approved for 1/2" to 1" EMT.
- For additional details refer to the full QM [Installation Manual](#).

CONDUIT MOUNT

QM CONDUIT MOUNT - COMPOSITION SHINGLE

Place conduit mounts along path of conduit. Lift shingle above mount location and insert flashing into position. Mark center for drilling, remove flashing and drill pilot hole with 1/8" bit. Clean area, fill hole with roofing manufacturer's approved sealant. Lift shingle and slide Conduit Mount into place. Prepare the lag bolt with sealing washer and pipe clamp (not included). Insert lag through hole in block and drill with 7/16" socket until block is tight.

- Install mounts as required to support conduit across the roof.
- For additional details refer to the full QM [Installation Manual](#).

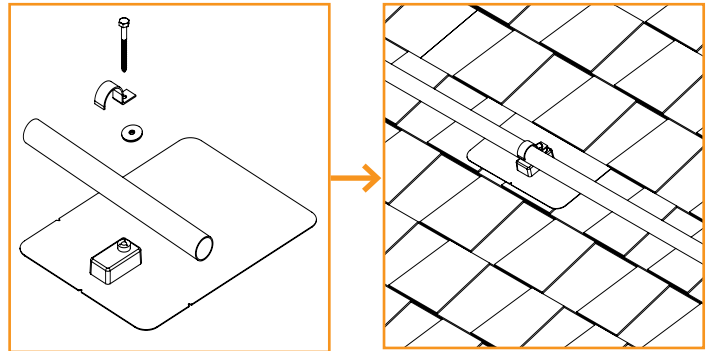

QM CONDUIT MOUNT - TILE

Remove the tile that the mount will be installed on, and the tiles in the course above it. Lift the bottom of the tile and slide the bottom clamp over the bottom edge of the tile. Insert the 4" tap bolt through the slot into the threaded hole and use a 7/16" socket to thread the screw. Tighten until the top clamp hook end unbends and forms a 90 degree angle with the tile. Use the Cap Screw (included) to attach your pipe clamp (not included) to bottom clamp. Insert conduit and tighten with 7/16" socket.

- The clamp is reversible, use the wider hook end on tile greater than 1" thick and the thinner hook end on tiles less than 1" thick.
- The installation process is the same on curved tile, make sure that the Conduit Mount is installed on the crown (high point) of the tile.
- Install mounts as required to support conduit across the roof.
- For additional details refer to the full QM [Installation Manual](#).

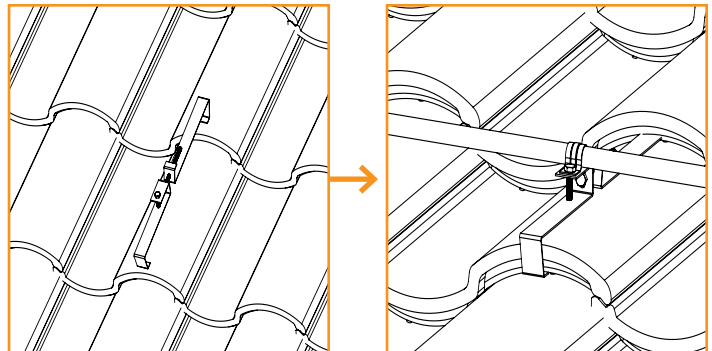

WIRE CLIPS

End Caps add a completed look and keep debris and pests from collecting inside rail.

Firmly press End Cap onto rail end.

- End Caps come in sets of left and right. Check that the proper amount of each has been provided.

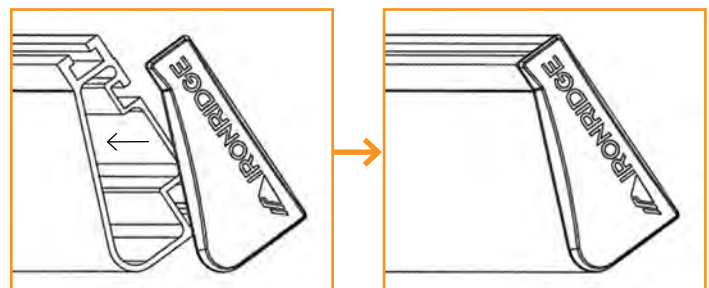

WIRE CLIPS

Wire Clips offer a simple wire management solution.

Firmly press Wire Clip into top rail slot. Run electrical wire through open clip. Snap closed once all wires have been placed.

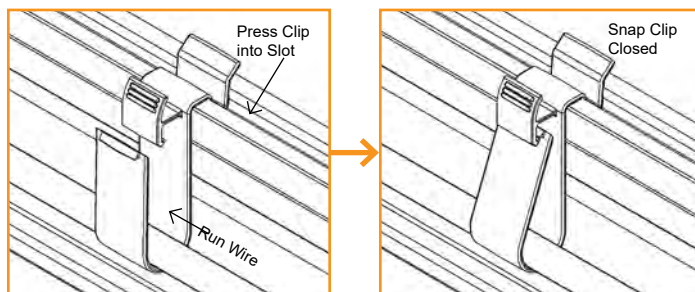

JAYBOX

A.

Prior to installation, use step drill bit to place pass through holes for conduits or water-tight connectors. Drill bit starter locations are provided on the sides and front of enclosure.

- Do not install conduit facing up roof.

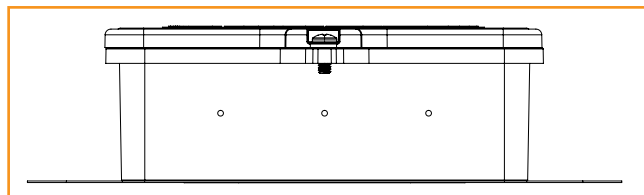

B (Rail).

Use rail-specific MLPE mounting hardware to attach Rail Hangers to rail. Ensure junction box is pushed as close to the rail as possible. Torque to 80-in lbs (1/2" or 7/16" socket).

- Do not overtighten
- If installing in areas with ground snow loads greater than 40 psf, install JayBox under module directly next to module frame edge.

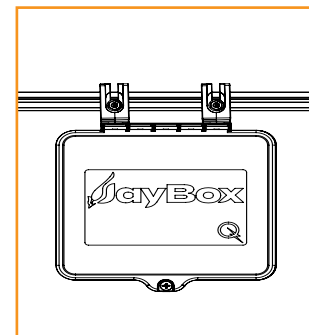
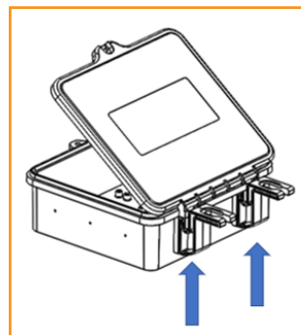

B (Shingle).

Align sealing oval of box to align with mating feature on flashing. An EPDM foam gasket is pre-installed to the underside of the junction box to seal the flashing to the box without the need for additional sealant. Secure with supplied #12 x 1-3/4" deck screws (2x) until the junction box is pulled tight to the flashing. Do not over-tighten screws to avoid stripping screws in OSB.

- If installing pass through fittings, ensure that the JayBox and roof deck are both properly prepared. Complete installation process before attaching the Jaybox to the deck.
- Do not install JayBox under shingle seam as illustrated below.

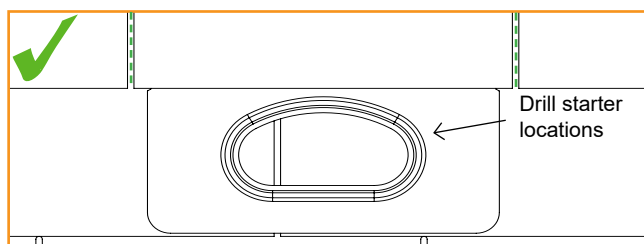
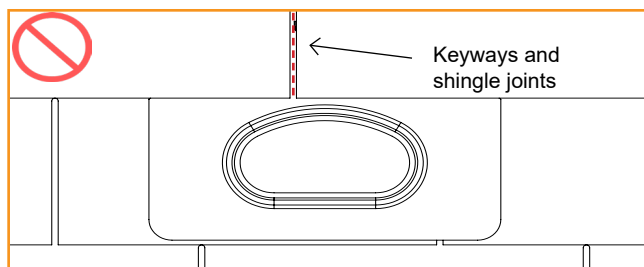
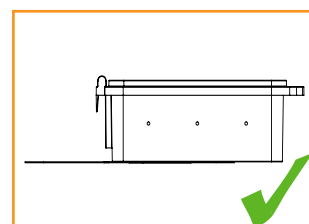
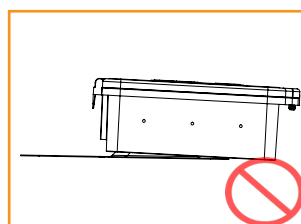

C.

Install wiring, conduit and fittings per NEC requirements and following local AHJ guidance. Using Philips Head Driver tighten the bolt.

- For additional details refer to the full QM [Installation Manual](#).

MICROINVERTER KITS

Use IronRidge's Microinverter Kit to bond compatible microinverters and power optimizers to the racking system.

Insert Microinverter Kit T-bolt into top rail slot. Place compatible microinverter or power optimizer into position and tighten hex nut to **80 in-lbs**.

- If installing in areas with ground snow loads greater than 40 psf, install MLPE devices directly next to module frame edge

COMPATIBLE PRODUCTS

Enphase

M250-72, 250-60, M215-60, C250-72, S230, S280, IQ 6, IQ 6+, IQ IQ7, IQ 7A, IQ 7+, IQ7 PD, IQ 7X, Q Aggregator; IQ8-60, IQ8PLUS-72, IQ8A-72, IQ8H-208-72, IQ8H-240-72, IQ8M-72, may be followed by -2-US

Darfon

MIG240, MIG300, G320, G640

Solar Edge

M1600, P300, P320, P340, P370, P400, P401, P405, P485, P505, P600, P700, P730, P750, P800p, P800s, P801, P850, P860, P950, P960, P1100, P1101, S440, S500, S1200, S1201

SMA

RoofCommKit-P2-US, TS4-R Module Retrofit Kits (TS4-R-S, TS4-R-O, TS4-R-F)

Tigo

Tigo Access Point (TAP)

TS4-R-X (where X can be F, M, O, or S)

TS4-R-X-DUO (where X can be M, O, or S)

TS4-A-X (where X can be F, 2F, O, O-DUO, or S)

Generac

S2502

AP Systems

DS3, QS1, QT2 and YC600

NEP

BDM-300, BDM-300X2 and BDM-800

- Remove Grounding Washer on AP Systems QS1, QT2, DS3 and YC600 inverters before installing to XR rails.
- Remove the Stainless Steel Clip on Tigo-"A" MLPE Devices before attaching to XR rails.
- Use the number of IronRidge Microinverter kits allowed by the MLPE mounting flange. Some will require 1 kit and others 2 kits.

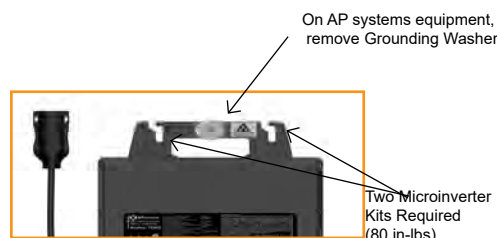
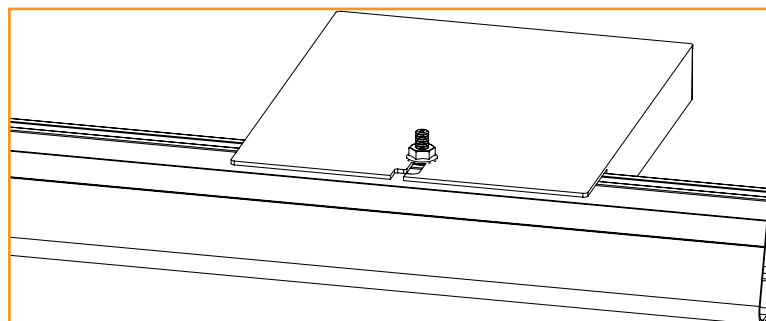
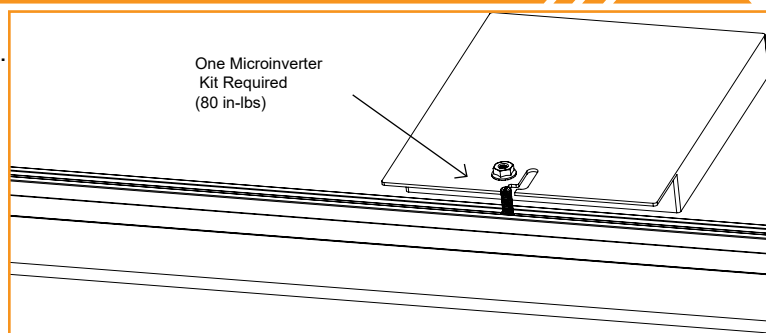

SYSTEMS USING ENPHASE MICROINVERTERS OR SUNPOWER AC MOD-

IronRidge systems using approved Enphase products or SunPower modules eliminate the need for lay-in lugs and field installed equipment grounding conductors (EGC). This solution meets the requirements of UL 2703 for bonding and grounding and is included in this listing.

COMPATIBLE PRODUCTS

Sunpower

Modules with model identifier Ab-xxx-YY and InvisiMount (G5) 46mm frame; where "A" is either E, or X; "b" can be 17, 18, 19, 20, 21, or 22; and "YY" can be C-AC, D-AC, BLK-C-AC, or BLK-D-AC.

Enphase

Microinverters M250-72, M250-60, M215-60, C250-72, and Engage cables ETXX-240, ETXX-208, ETXX-277.

- A minimum of two inverters mounted to the same rail and connected to the same Engage cable are required.
- The microinverters or Sunpower AC modules must be used with a maximum 20 A branch rated overcurrent protection device (OCPD).
- If an AC module is removed from a circuit for maintenance, you must first disconnect AC power and then install a temporary EGC to bridge the gap by inserting an AC extension cable (or via other NEC-compliant means), in order to maintain effective ground continuity to subsequent modules.

SYSTEMS USING MICROSTORAGE PRODUCTS

Use IronRidge's Microinverter Kit to bond compatible microstorage devices to the racking system. Insert Microinverter Kit T-bolt into top rail slot. Place compatible microstorage into position and tighten hex nut to **80 in-lbs**.

COMPATIBLE PRODUCTS

PHAZR

PHAZR Devices PHAZR-X, where X is 6-12.

Solpad

Solpad Inverter model SI-1k

Solpad Battery Storage model SB-2K

Solpad Junction Box model SJB-4k

- Running a separate equipment grounding conductor to the PHAZR or Solpad devices is not required.
- If installing in areas with ground snow loads greater than 40 psf and underneath a module, install PHAZR and Solpad devices as close as possible to module frame edge.
- Solpad may only be installed on XR-100 and XR-1000
- Solpad may only be installed with modules having a frame thickness of 35mm or greater.
- Use the number of IronRidge Microinverter kits allowed by the microstorage mounting flange. Some will require 1 kit and others 2 kits.

PHAZR

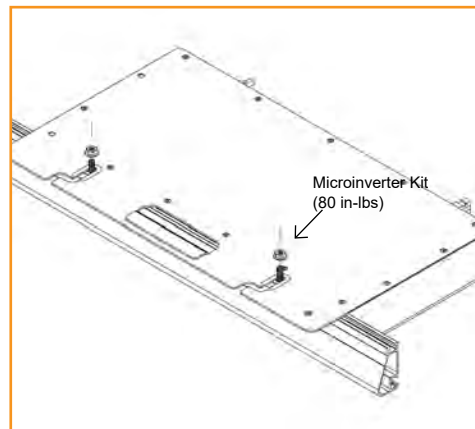

Solpad

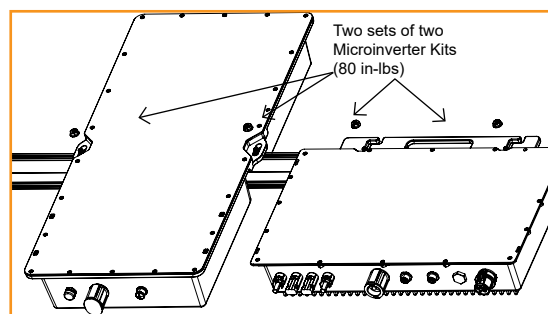

FRAMELESS MODULE KITS

Insert Frameless Kit T-bolt in top rail slot. Place star washer over T-bolt, allowing it to rest on top of rail. Secure module clamps with a hex nut and torque to **80 in-lbs**.

COMPATIBLE PRODUCTS

Sunforson

Sunforson silver or black SFS-UTMC-200(B) mid and SFS-UTEC-200(B) end clamps.

Sunpreme

Sunpreme silver or black mid and end clamps with part numbers 7500105X where "X" is 1, 5, 6 or 7.

Ironridge

IronRidge silver or black mid and end clamps with part numbers FMLS-XC-001-Y where "X" is E or M and "Y" is B or blank.

- Follow module manufacturer's installation instructions to install the module clamps.
- Frameless modules require using a Grounding Lug on every rail.
- For Sunpreme Modules Only: If required to use slide prevention hardware, see Module Slide Prevention Addendum (Version 1.10).

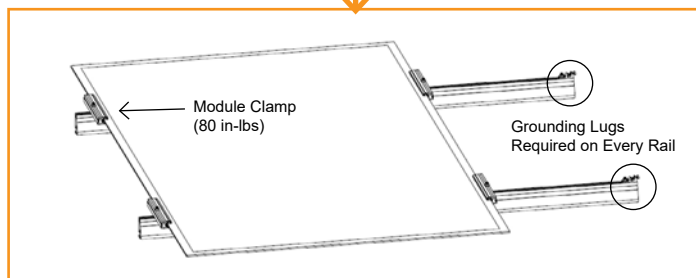
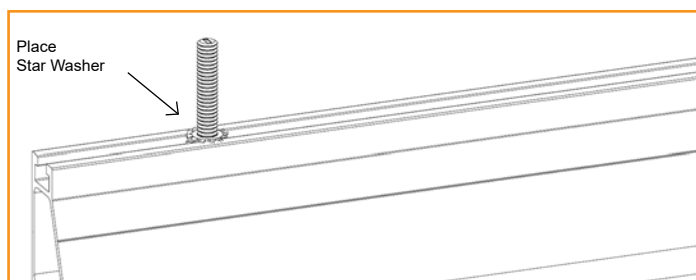

Install Contour

Install Contour on a completed array.

A. Start by placing Contour Clamp on module frame within 12 inches of the down roof corner of the array. Each piece of 84" Contour Trim must be supported by two Clamps. Clamps must be installed in the 12" clamping zones at edge of trim. Once trim is placed and in position, secure trim by tightening Clamp set screw to **80 in-lbs**.

B. Multiple Contour pieces can be joined using Contour Splice. Install Splice on existing Contour edge and install Clamps in appropriate clamping zones for next piece of trim. Place trim on Clamps, slide into splice to join two pieces together. Secure Contour by tightening Clamp set screw to **80 in-lbs**. Repeat as needed across the array.

C. Cut trim to line up with edge of array.

D. Install Clamps within clamping zones on side of array. Install second Clamp as needed up array. Place Corner Cap on trim and slide side trim to align with Cap. Repeat as needed along roof for both inside and outside corners.

E. Use optional End Caps to cover any exposed edges of Contour as desired.

- Do not install on side of array facing roof peak.
- Contour can be installed with 1 clamp if trim section is 12" long (or shorter) and has a splice attached on one end, on which the section of trim the 12" section is spliced to also has 2 clamps.
- Contour Trim when installed when installed up roof requires the use of Aire Stealth Clamps.
- Wind Speed: no restrictions
- Ground Snow: up to 90 PSF

A.

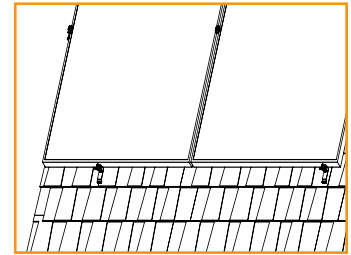
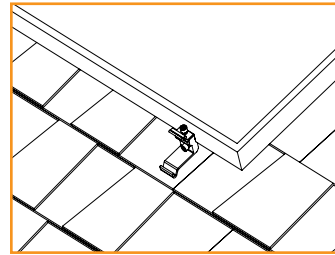
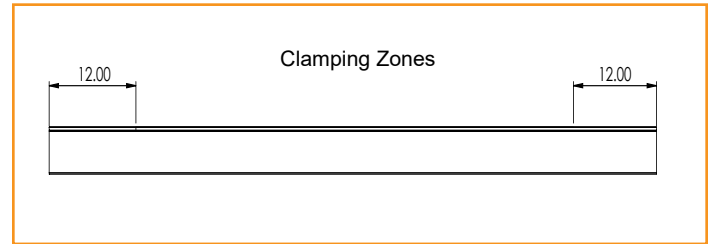

B.

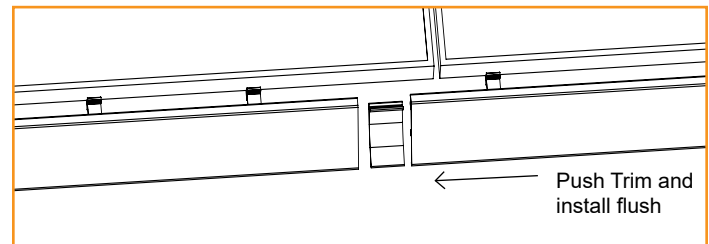

C.

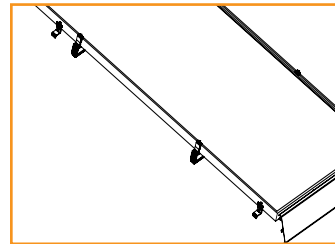

D.

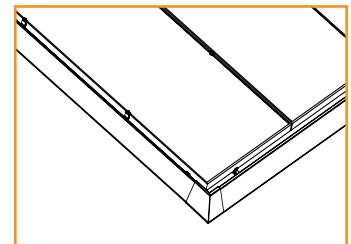

E.

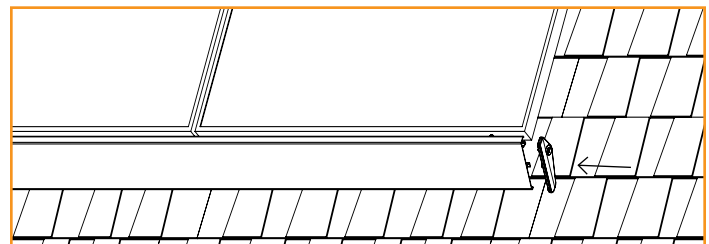

MODULE COMPATIBILITY

The Flush Mount System may be used to ground and/or mount a PV module complying with UL 2703 only when the specific module has been evaluated for grounding and/or mounting in compliance with the included instructions. Unless otherwise noted, "xxx" refers to the module power rating and both black and silver frames are included in the certification.

FRAMED MODULE LIST

MAKE	MODELS
Adani	Adani modules with 35 and 40mm frames ASX-Y-ZZ-xxx Where "X" can be B, M or P; "Y" can be 6, 7 or M10 and "ZZ" can be blank, 144, PERC, B-PERC, or AB-PERC
AIONRISE	AIONRISE modules with 35 and 40mm frames AIONyyG1-xxx Where "yy" can be 60 or 72
Amerisolar	Amerisolar modules with 35 and 40 mm frames AS-bYxxxZ Where "b" can be 5 or 6; "Y" can be M, P, M27, P27, M30, or P30; and "Z" can be blank, W or WB
Aptos Solar	Aptos modules with 35 and 40 mm frames DNA-yy-zzaa-xxx Where "yy" can be 120 or 144; "zz" can be MF or BF; and "aa" can be 23 or 26
Astronergy Solar	Astronergy modules with 30, 35 and 40 mm frames aaSMbbyyC/zz-xxx Where "aa" can be CH or A; "bb" can be 60, 66, or 72; "yy" can be blank, 10 or 12; "C" can be M, P, M(BL), M-HC, M(BL)-HC, P-HC, M(DG), or M(DGT); and "zz" can be blank, HV, F-B, or F-BH
ASUN	ASUN modules with 35 and 40 mm frames ASUN-xxx-YYZZ-aa Where "YY" can be 60 or 72; "ZZ" can be M, or MH5; and "aa" can be blank or BB
Auxin	Auxin modules with 40 mm frames AXN6y6zAxxxB Where "y" can be M or P; "z" can be 08, 09, 10, 11, or 12; and "A" can be F, M or T; and "B" can be blank, A, B or C
Axitec	Axitec Modules with 30, 35 and 40 mm frames AC-xxxY/aaZZb Where "Y" can be M, P, MB or MH; "aa" can be blank, 125- or 156-; "ZZ" can be 54, 60, 72, 108, 120, or 144; "b" can be S, X, V, VB, XV, or MX
Bluesun Solar	Bluesun modules with 30 and 35mm frames BSMxxxY-AAA Where "Y" can be M or M10; and "AAA" can be 54HPH, 60HPH or 72HBD
Boviet	Boviet modules with 35 and 40mm frames BVMZZaaYY-xxxBcc Where "ZZ" can be 66 or 76; "aa" can be 9, 10 or 12; "YY" is M or P; and "B" can be blank, L or S; and "cc" can be blank, H, H-BF, H-BF-DG, H-HC, H-HC-BF, H-HC-BF-DG, HC-BF or HC-BF-DG
BYD	BYD modules with 35 mm frames BYDxxxAY-ZZ Where "A" can be M6, P6, MH or PH; "Y" can be C or K; and "ZZ" can be 30 or 36
Canadian Solar	Canadian Solar modules with 30, 32, 35 and 40 mm frames CSbY-xxxZ Where "b" can be 1, 3, 6 or 7 "Y" can be H, K, L, N, P, R, U, V, W, X or Y; and "Z" can be M, P, MS, PX, M-SD, P-AG, P-SD, MB-AG, PB-AG, MS-AG, MS-HL, or MS-SD
CertainTeed	CertainTeed modules with 35 and 40 frames CTxxxYZZ-AA Where "Y" can be M, P, or HC; "ZZ" can be 00, 01, 10, or 11; and "AA" can be 01, 02, 03, 04 or 06

MODULE COMPATIBILITY

CSUN	<p>Csun modules with 35 and 40 mm frames YYxxx-zzAbb Where "YY" is CSUN or SST; "zz" is blank, 60, or 72; and "A" is blank, P, M or MM; "bb" is blank, BB, 5BB, BW, or ROOF</p>
Dehui	<p>Dehui modules with 30, 35 and 40mm frames DH-MYYYY-xxx Where "YYYY" can be 760, 772, 860, 872; and "Z" can be B, F or W</p>
Ecosolargy	<p>Ecosolargy modules with 35 and 40 mm frames ECOxxxYzzA-bbD Where "Y" can be A, H, S, or T; "zz" can be 125 or 156; "A" can be M or P; "bb" can be 60 or 72; and "D" can be blank or B</p>
ET Solar	<p>ET Solar modules with 30, 35 and 40 mm frames ET-YZZZxxxAA Where "Y" can be P, L, or M; "ZZZ" can be 660, 660BH, 672, 672BH, 754BH, 766BH, 772BH; and "AA" can be GL, TB, TW, WB, WW, BB, WBG, WWG, WBAC, WBCO, WWCO, WWBCO or BBAC</p>
Flex	<p>Flex modules with 35 and 40 mm frames FXS-xxxYY-ZZ; Where "YY" can be BB or BC; and "ZZ" can be MAA1B, MAA1W, MAB1W, SAA1B, SAA1W, SAC1B, SAC1W, SAD1W, SBA1B, SBA1W, SBC1B, or SBC1W</p>
Freedom Forever	<p>Freedom Forever modules with 35mm frames FF-MP-BBB-xxx</p>
GCL	<p>GCL modules with 35 mm and 40 mm frames GCL-ab/YY xxx Where "a" can be M or P; "b" can be 3 or 6; and "YY" can be 60, 72, 72H, or 72DH</p>
GigaWatt Solar	<p>Gigawatt modules with 40 mm frames GWxxxYY Where "YY" can be either PB or MB</p>
Hansol	<p>Hansol modules with 35 and 40 frames HSxxxYY-zz Where "YY" can be PB, PD, PE, TB, TD, UB, UD, or UE; and "zz" can be AH2, AN1, AN3, AN4, HH2, HV1, or JH2</p>
Hanwa Solar	<p>Hanwa Solar modules with 40 mm frames HSLaaP6-YY-1-xxxZ Where "aa" can be either 60 or 72; "YY" can be PA or PB; and "Z" can be blank or B</p>
Hanwa Q CELLS	<p>Hanwa Q CELLS Modules with 32, 35, 40mm frames aaYY-ZZ-xxx where "aa" can be Q. or B.; "YY" can be PLUS, PRO, PEAK, LINE PRO, LINE PLUS, PLUS DUO or PEAK DUO; and "ZZ" can be G3, G3.1, G4, G4.1, L-G2, L-G2.3, L-G3, L-G3.1, L-G3y, L-G4, L-G4.2, L-G4y, LG4.2/ TAA, BFR-G3, BLK-G3, BFR-G3.1, BLK-G3.1, BFR-G4, BFR-G4.1, BFR G4.3, BLK-G4.1, G4/SC, G4.1/SC, G4.1/TAA, G4.1/MAX, BFR G4.1/TAA, BFR G4.1/MAX, BLK G4.1/TAA, BLK G4.1/SC, EC-G4.4, G5, G5/ SC, G5/TS, BLK-G5, BLK-G5/SC, BLK-G5/TS, L-G5, L-G5.1, L-G5.2, L-G5.2/H, L-G5.3, G6, G6/SC, G6/TS, G6+/TS, G6+, BLK-G6, L-G6, L-G6.1, L-G6.2, L-G6.3, G7, BLK-G6+, BLK-G6+/AC, BLK-G6+/HL, BLK-G6+/ SC, BLK-G6/TS, BLK-G6+/TS, BLK-G7, G7.2, G8, BLK-G8, G8+, BLK-G8+ L-G7, L-G7.1, L-G7.2, L-G7.3, L-G8, L-G8.1, L-G8.2, L-G8.3, L-G8.3/BFF, L-G8.3/BFG, L-G8.3/BGT, ML-G9, BLK ML-G9, ML-G9+, BLK ML-G9+, BLK-G10+, BLK G10+/AC, ML-G10, BLK ML-G10, ML-G10+, BLK ML-G10+, ML-G10.a, BLK ML-G10.a, ML-G10.a+, BLK ML-G10.a+, XL-G9, XL-G9.2, XL-G9.3, XL-G9.3/BFG, XL-G10.2, XL-G10.3, XL-G10.c, XL-G10.d, XL-G10.d/BFG, XL-G10.3/BFG, XL-G11.2, XL-G11.3 or XL-G11.3/BFG</p>
Heliene	<p>Heliene modules with 35 and 40 mm frames YYZZxxxA Where "YY" can be 36, 60, 72, 96, 120 or 144; "ZZ" can be HC, M, P, or MBLK; and "A" can be blank, HomePV, Bifacial, M10 Bifacial or M10 SL-Bifacial</p>
HT-SAAE	<p>HT-SAAE modules with 35 and 40 mm frames HTyy-aaaZ-xxx Where "yy" can be 60, 66, 72 or 78, "aaa" can be 18, 156 or 166, "Z" can be M, P, M-C, P-C, M(S), M(VS), M(V), P(V), M(V)-C, P(V)-C, or X</p>

MODULE COMPATIBILITY

Hyundai	Hyundai modules with 32, 33, 35 and 40mm frames HiY-SxxxZZ Where "Y" can be A, D or S; "S" can be M or S; and "ZZ" can be GI, HG, HI, KI, MI, MF, MG, PI, RI, RG, RG(BF), RG(BK), SG, TI, TG, YH(BK) or XG(BK)
Itek	Itek Modules with 40 mm frames IT-xxx-YY Where "YY" can be blank, HE, or SE, or SE72
JA Solar	JA Solar modules with 30, 35 and 40 mm frames JAyzz-bbww-xxx/aa Where "yy" can be M, P, M6 or P6; "zz" can be blank, (K), (L), (R), (V), (BK), (FA), (TG), (FA)(R), (L)(BK), (L)(TG), (R)(BK), (R)(TG), (V)(BK), (BK)(TG), or (L)(BK)(TG); "bb" can be 48, 54, 60, 66, 72 or 78; "ww" can be D09, D10, D20, D30, S01, S02, S03, S06, S09, S10, S12, S17, S20, S30 or S31; and "aa" can be BP, MB, MR, SI, SC, PR, 3BB, 4BB, 4BB/RE, 5BB
Jinko	Jinko modules with 35 and 40 mm frames JKMYxxxZZ-aa Where "Y" can either be blank or S; "ZZ" can be M, P, or PP; and "aa" can be blank, 60, 60B, 60H, 60L, 60BL, 60HL, 60HB, 60HBL, 6HBL-EP, 60-J4, 60B-J4, 60B-EP, 60(Plus), 60-V, 60-MX, 6RL3, 6RL3-B, 6TL3-B, 7RL3-V, 7RL3-TV, 72, 72B, 72-J4, 72B-J4, 72(Plus), 72-V, 72H-V, 72L-V, 72HL-V, 72HL4-V, 72HL4-TV, 72-MX, 72H-BDVP, 72HL-TV, or 72HL-V-MX3
Kyocera	Kyocera Modules KYxxxZZ-AA Where "Y" can be D or U; "ZZ" can be blank, GX, or SX; and "AA" can be LPU, LFU, UPU, LPS, LPB, LFB, LFBS, LFB2, LPB2, 3AC, 3BC, 3FC, 4AC, 4BC, 4FC, 4UC, 5AC, 5BC, 5FC, 5UC, 6BC, 6FC, 8BC, 6MCA, or 6MPA
LG	LG modules with 35 and 40 mm frames LGxxxYaZ-bb Where "Y" can be A, E, M, N, Q, S; "a" can be A, 1, 2 or 3 "Z" can be C, K, T, or W; and "bb" can be A3, A5, A6, B3, B6, E6, E6.AW5, G3, G4, J5, K4, L5, N5, V5, V6
Longi	Longi modules with 30, 35 and 40 mm frames LRa-YYZZ-xxxM Where "a" can be 4, 5 or 6; "YY" can be blank, 60, 66, or 72; and "ZZ" can be blank, BK, BP, HV, PB, PE, PH, HBD, HIB, HIH, HPB, HPH, or HIBD
Maxeon	Maxeon modules with 35, 40 and 46mm frames SPR-AAAY-xxx-zzz Where "AAA" can be MAX, P or X; "Y" can be 3, 5, 6, 21 or 22; and "zzz" can be BLK, COM or UPP
Meyer Burger	Meyer Burger Modules with 35mm frames Meyer Burger Black or White
Mission Solar	Mission Solar modules with 33, 35 and 40 mm frames YYYbb-xxxZZaa Where "YYY" can be MSE or TXS; "bb" can be blank, 6 or 60A; "ZZ" can be blank, MM, SE, SO, SQ, SR, SX, TS, 120 or 144; and "aa" can be blank, BB, BW, 1J, 4J, 4S, 5K, 5R, 5T, 60, 6J, 6S, 6W, 6Z, 8K, 8T, or 9S
Mitsubishi	Mitsubishi modules PV-MYYxxxZZ Where "YY" can be LE or JE; and "ZZ" can be either HD, HD2, or FB
Moltech	IM and XS series modules with 40 mm frames
Next Energy Alliance	Next Energy Alliance modules with 35 and 40mm frames yyNEA-xxxZZ where "yy" can be blank or US; "ZZ" can be M, MB or M-60
Neo Solar Power	Neo Solar Power modules with 35 mm frames D6YxxxZZaa Where "Y" can be M or P; "ZZ" can be B3A, B4A, E3A, E4A, H3A, H4A; and "aa" can be blank, (TF), ME or ME (TF)

MODULE COMPATIBILITY

Panasonic (HIT)	Panasonic modules with 35 and 40 mm frames VBHNxxxYYzZA Where "YY" can be either KA, RA, SA or ZA; "zz" can be either 01, 02, 03, 04, 06, 06B, 11, 11B, 15, 15B, 16, 16B, 17, or 18; and "A" can be blank, E, G, or N
Panasonic (EverVolt)	Panasonic modules with 30 mm frames EVPVxxxA Where "A" can be blank or H, K or PK
Peimar	Peimar modules with 40 mm frames SbxxxYzz Where "b" can be G, M or P; "Y" can be M or P; and "zz" can be blank, (BF) or (FB)
Philadelphia Solar	Philadelphia modules with 35 and 40 mm frames PS-YzzAA-xxx Where "Y" can be M or P; "zz" can be 60, 72 or 144; and "AA" can be blank, (BF), (HC) or (HCBF)
Phono Solar	Phono Solar modules with 30, 35 and 40mm frames PSxxxY-ZZ/A Where "Y" can be M, M1, MH, M1H, M4, M4H, M5GF, M5GFH, M6, M6H, M8GF, M8GFH or P; "ZZ" can be 18, 20 or 24; and "A" can be F, T, TH, U, UH, UHB, VH or VHB
Prism Solar	Prism Solar modules with 35mm frames PST-xxxW-M72Y Where "Y" can be H, HB or HBI
Recom	Recom modules with 35 and 40 mm frames RCM-xxx-6yy Where "yy" can be MA, MB, ME or MF
REC Solar	REC modules with 30 and 38 mm frames RECxxxYYZZ Where "YY" can be AA, M, NP, NP2, PE, PE72, TP, TP2, TP2M, TP2SM, TP2S, TP3M or TP4; and "ZZ" can be blank, Black, BLK, BLK2, SLV, 72, or Pure
Renesola	ReneSola modules with 35 and 40 mm frames AAxxxY-ZZ Where "AA" can be SPM(SLP) or JC; "Y" can be blank, F, M or S; and "ZZ" can be blank, Ab, Ab-b, Abh, Abh-b, Abv, Abv-b, Bb, Bb-b, Bbh, Bbh-b, Bbv, Bbv-b, Db, Db-b, or 24/Bb
Renogy	Renogy Modules with 40 mm frames RNG-xxxY Where "xxx" is the module power rating; and "Y" can be D or P
Risen	Risen Modules with 30, 35 and 40 mm frames RSMyy-a-xxxZZ Where "yy" can be 60, 72, 110, 120, 132 or 144; "a" can be 6, 7 or 8; and "ZZ" can be M, P or BMDG
S-Energy	S-Energy modules with 35 and 40mm frames SABB-CCYYY-xxxZ Where "A" can be C, D, L or N; "BB" can be blank, 20, 25, 40 or 45; "CC" can be blank, 60 or 72; "YYY" can be blank, BDE, MAE, MAI, MBE, MBI, MCE or MCI; and "Z" can be V, M-10, P-10 or P-15
SEG Solar	SEG Solar with 30, 35 and 40 mm frames SEG-aYY-xxxZZ Where "a" can be blank, 6 or B; "YY" can be blank, MA, MB, PA, or PB; and "ZZ" can be blank, BB, BG, BW, HV, WB, WW, BMB, BMA-HV, BMA-BG, BMA-TB, BMB-TB, BMB-HV, BMD-HV, BMB-BG
Seraphim USA	Seraphim modules with 30, 35 and 40 mm frames SRP-xxx-YYY-ZZ Where "xxx" is the module power rating; and "YYY" can be BMA, BMD, 6MA, 6MB, 6PA, 6PB, 6QA-XX-XX, and 6QB-XX-XX; ZZ is blank, BB, BG or HV
Sharp	Sharp modules with 35 and 40 mm frames NUYYxxx Where "YY" can be SA or SC

MODULE COMPATIBILITY

Shinsung E&G	Shinsung Modules with 35mm frames SSVxxx-144MH
Silfab	Silfab Modules with 35 and 38 mm frames SYY-Z-xxxAb Where "YY" can be IL, SA, LA, SG or LG; "Z" can be blank, M, P, or X; "A" can be blank, B, H, M, N; and "b" can be A, C, G, K, L, N, T, U or X
Solaria	Solaria modules with 35 and 40 mm frames PowerA-xxxY-ZZ Where "A" can be X or XT, "Y" can be R or C; and "ZZ" can be blank, AC, BD, BX, BY, PD, PL, PM, PM-AC, PX, PZ, WX or WZ
Solarcity (Tesla)	Solarcity modules with 40 mm frames SCxxxYY Where "YY" can be blank, B1 or B2
SolarTech	SolarTech modules with 40 mm frames AAA-xxxYY Where "AAA" can be PERCB-B, PERCB-W, HJT B-B, HJT B-W or STU; "YY" can be blank, PERC or HJT
SolarWorld AG	SolarWorld Sunmodule Plus, Protect, Bisun, XL, Bisun XL, may be followed by mono, poly, duo, black, bk, or clear; modules with 31 and 33 mm frames SW-xxx
SolarWorld Americas	SolarWorld Sunmodule Plus, Protect, Bisun, XL, Bisun XL, may be followed by mono, poly, duo, black, bk, or clear; modules with 33 mm frames SWA-xxx
Sonali	Sonali Modules with 35 and 40 mm frames SS-M-xxx Where "M" can be blank or M
Stion	Stion Thin film modules with 35 mm frames STO-xxx or STO-xxxA
SunEdison	SunEdison Modules with 35 and 40 mm frames SE-YxxxZABCDE Where "Y" can be B, F, H, P, R, or Z; "Z" can be 0 or 4; "A" can be B,C,D,E,H,I,J,K,L,M, or N ; "B" can be B or W; "C" can be A or C; "D" can be 3, 7, 8, or 9; and "E" can be 0, 1 or 2
Suniva	Suniva modules with 35, 38 and 40 mm frames OPTxxx-AA-B-YYY-Z MVXxxx-AA-B-YYY-Z Where "AA" is either 60 or 72; "B" is either 4 or 5; "YYY" is either 100,101,700,1B0, or 1B1; and "Z" is blank or B
Sunmac Solar	Sunmac Solar modules with 30 and 35mm frames SMxxxMaaaZZ-BB Where "aaa" can be 660 or 754; and "ZZ" can be NH or SH
Sunpower	Sunpower standard (G3 or G4) or InvisiMount (G5) 35 and 40mm frames SPR-Zb-xxx-YY Where "Z" can be A, E, M, P or X; "b" can be blank, 17, 18, 19, 20, 21, or 22; and "YY" can be blank, BLK, COM, C-AC, D-AC, E-AC, BLK-E-AC, G-AC, BLK-G-AC, H-AC, BLK-H-AC, BLK-C-AC, or BLK-D-AC
Sunspark	Sunspark modules with 40 mm frames SYY-xxxZ-A Where "YY" can be MX or ST; and "Z" can be M, MB, M3, M3B, P or W; and "A" can be 60 or 72
Suntech	Suntech Modules with 35 and 40mm frames STPxxx-y-zz/aa Where "y" is blank or S; and "zz" can be 20, 24, A60, A72U, B60 or B72; and "aa" can be Vd, Vem, Vfw, Vfh, Vnh, Wdb, Wde, Wd, Wfhb or Wnhb
Talesun	Talesun modules with 30, 35 and 40mm frames TAByZZaa-xxx-b Where "A" can be D or P; "B" can be 6 or 7; "y" can be blank, F, G, H, I or L; "ZZ" can be 60, 66, 72 or 78; "aa" can be M, M(H), or P; and "b" can be blank, B, T, or (H)

MODULE COMPATIBILITY

Tesla	<p>Tesla modules with 40 mm frames TxxxY Where "Y" can be H or S</p>
Trina	<p>Trina Modules with 30, 35 and 40mm frames TSM-xxxYYZZ Where "YY" can be DD05, DD06, DD14, DE14, DE15, DE15V, DEG15, DEG15VC, DE18M, DEG18MC, DE09, DE19, DEG19C.20, DE06X, PA05, PC05, PD05, PD06, PA14, PC14, PD14, PE14, or PE15 ; and "ZZ" can be blank, .05, .05(II), .08, .08(II), .10, .18, .08D, .18D, 0.82, .002, .00S, 05S, 08S, .20(II), A, A.05, A.08, A.10, A.18, (II), A(II), A.05(II), A.08(II), A.082(II), A.10(II), A.18(II), C.05, C.07, C.05(II), C.07(II), H, H(II), H.05(II), H.08(II), HC.20(II), HC.20(II), M, M(II), M.05(II), MC.20(II)</p>
URE	<p>URE modules with 35 mm frames DyZxxxxa Where "D" can be D or F, "y" can be A, B, 6 or 7; "Z" can be K or M; and "aa" can be C8G, H3A, H4A, H8A, E7G-BB, E8G, E8G-BB or MFG-BB</p>
Vikram	<p>Vikram solar modules with 35 and 40 mm frames XVSyy.ZZ.AAA.bb Where "X" can be blank, Paradea, Prexos or Somera; "yy" can be M, P, MBB, MDH, MDHT, MH, MS, MHBB, or PBB; "ZZ" can be 60 or 72; "AAA" is the module power rating; and "bb" can be 03, 04 or 05</p>
VSUN	<p>VSUN modules with 30, 35 and 40 mm frames VSUNxxx-YYz-aa Where "YY" can be 60, 72, 108, 120, or 144; "z" can be M, P, MH, PH, or BMH; and "aa" can be blank, BB, BW, or DG</p>
Waaree	<p>Waaree modules with 40mm frames AAyy-xxx Where "AA" can be WS or Bi; and "yy" can be blank, M, MB, 55 or 66</p>
Winaico	<p>Winaico modules with 35 and 40 mm frames Wsy-xxxZa Where "y" can be either P or T; "Z" can be either M, P, or MX; and "a" can be blank or 6</p>
Yingli	<p>Yingli modules with 35 and 40 mm frames YLxxxZ-yy Where "Z" can be D or P; "yy" can be 29b, 30b, 34d, 35b, 36b or 40d</p>
ZN Shine	<p>ZN Shine modules with 35mm frames ZXMY-AAA-xxx/M Where "Y" can be 6, 7 or 8; "AAA" can be 72, NH120, NH144, NHDB144, NHLDD144, SH144, SHDB144, SHLDD144 or TP120</p>

MODULE COMPATIBILITY

FRAMELESS MODULE LIST

MAKE	MODELS
Astronergy Solar	Astronergy frameless modules CHSM6610P(DG)-xxx
Canadian Solar	Canadian Solar frameless modules CSbY-xxx-Z Where "b" can be 3 or 6; "Y" is K, P, U, or X; and "Z" can be M-FG, MS-FG, P-FG, MB-FG, or PB-FG
Heliene	Heliene frameless modules YYZZxxxA Where "YY" can be 72; "ZZ" can be M; and "A" can be GH
Jinko	Jinko frameless modules JKMxxxPP-DV
Prism Solar	Prism Solar frameless modules BZYY-xxxAAA Where "Z" can be i or N; "YY" can be 48, 60, 60S, 72 or 72S; and "AAA" can be blank or BSTC
Risen	Risen frameless modules RSMyy-6-xxxZZ Where "yy" can be 60, 72, 120 or 144; and "ZZ" can be MDG or PDG
Stion	Stion frameless modules STL-xxx or STL-xxxA
Sunpreme	Sunpreme frameless modules GXB-xxxYY Where "YY" can be blank or SL
Trina	Trina frameless modules TSM-xxxYY Where "YY" can be either DEG5(II), DEG5.07(II), DEG5.40(II), DEG5.47(II), DEG14(II), DEG14C(II), DEG14C.07(II), DEG14.40(II), PEG5, PEG5.07, PEG5.40, PEG5.47, PEG14, or PEG14.40