



LEADING THE WAY  
Structural Engineering Firm  
NC License No. C-2499

168 Quade Drive  
Cary, North Carolina 27513  
www.rbengineering.com

Phone: 919-677-9662 / Cell: 919-280-2695 / Fax: 919-677-9663

E-mail: [rbittler@rbengineering.com](mailto:rbittler@rbengineering.com)

Mr. Evan McNeil

August 15, 2023

**Yes! Solar Solutions of the Triangle**

E-mail: [emcneil@yessolarsolutions.com](mailto:emcneil@yessolarsolutions.com)

Subject: Roof mounted solar panels – Tilley Residence  
175 Rocky Point Court  
Fuquay Varina, North Carolina 27526

File No.: RB-239177

Dear Evan:

RB Engineering, Inc. is pleased to provide the following summary engineering letter concerning the subject project. The existing roof system is constructed with timber trusses at 24 inches on center, OSB roof deck and a composition asphalt shingle roof. We have reviewed the proposed solar layout and have structurally evaluated the additional proposed roof loading with the following conclusions:

- The total surface area of the new proposed solar array (18 PV modules) is approximately 420 SF. The solar panel installation has been evaluated for an ultimate design wind speed of 120 mph.
- The subject roof mounted PV system attachment method is structurally adequate to transfer the design uplift loads in accordance with the 2018 North Carolina residential building code.
- The existing roof system is structurally adequate to transfer the applicable design loads - including the additional or modified design loading (dead, wind and snow loads) due to the proposed solar panel installation - in accordance with the 2018 North Carolina residential building code.

Our services were provided in accordance with the standard of practice for structural engineering and within the limits imposed by scope, schedule, and budget. If you have any questions or if I can be of further assistance to you on this project, please contact me at (919) 677-9662.

Respectfully submitted,

Ron Bittler, PE  
President / Structural Engineer  
RB Engineering, Inc.



**NEW PHOTOVOLTAIC SYSTEM 7.920kW DC / 7.600kW AC**  
**175 ROCKY POINT COURT, FUQUAY-VARINA, NC 27526**

**AHJ**

NC-COUNTY OF HARNETT

**UTILITY**

DUKE ENERGY (PROGRESS ENERGY CAROLINAS INC)

**CODES AND STANDARDS**

ELECTRIC CODE: NEC 2017 WITH NC AMENDMENTS  
 FIRE CODE: NCFC 2018  
 BUILDING CODE: NCBC 2018  
 RESIDENTIAL CODE: NCRC 2018  
 WIND SPEED: 116 MPH  
 SNOW LOAD: 15 PSF  
 HIGH TEMP: 36°C, LOW TEMP: -9°C

**SCOPE OF WORK**

(N) 7.920kW DC / 7.600kW AC ROOF MOUNT PV SYSTEM  
 (18) CERTAINTEED SOLAR CT440HC11-06 440W (440W) MODULES  
 (1) TESLA SOLAR (7.6KW) INVERTER  
 (7) TESLA SOLAR SHUTDOWN DEVICE (MCI)

**VICINITY MAP**

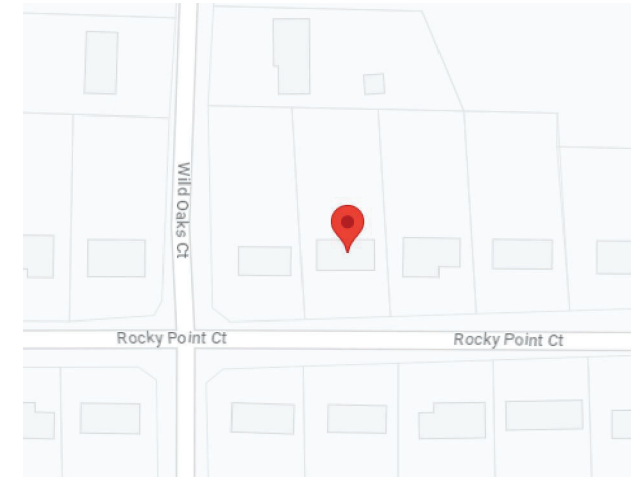

**CONTRACTOR INFORMATION**



YES SOLAR SOLUTIONS  
 ADDRESS: 202 NORTH DIXON AVENUE, CARY, NC 27513  
 PHONE NUMBER: (919) 375-0757

**CUSTOMER INFORMATION**

NAME: ADRIENNE TILLEY  
 ADDRESS: 175 ROCKY POINT COURT, FUQUAY-VARINA, NC 27526  
 COORDINATES: 35.526664, -78.852680  
 APN: 0644568676  
 7.920kW DC / 7.600kW AC ROOF MOUNT PV SYSTEM

**GENERAL NOTES**

1.MODULES ARE LISTED UNDER UL 1703 / UL 61730 AND CONFORM TO THE STANDARDS.  
 2.INVERTERS ARE LISTED UNDER UL 1741 AND CONFORM TO THE STANDARDS.  
 3.DRAWINGS ARE DIAGRAMMATIC, INDICATING GENERAL ARRANGEMENT OF THE PV SYSTEM. ACTUAL SITE CONDITIONS MAY VARY.  
 4.WORKING CLEARANCES AROUND THE NEW PV ELECTRICAL EQUIPMENT SHALL BE MAINTAINED IN ACCORDANCE WITH NEC 110.26.  
 5.ALL GROUND WIRING CONNECTED TO THE MAIN SERVICE GROUNDING IN MAIN SERVICE PANEL / SERVICE EQUIPMENT.  
 6.ALL CONDUCTORS SHALL BE 600V, 90°C STANDARD COPPER UNLESS OTHERWISE NOTED.  
 7.WHEN REQUIRED, A LADDER SHALL BE IN PLACE FOR INSPECTION IN COMPLIANCE WITH OSHA REGULATIONS.  
 8.THE SYSTEM WILL NOT BE INTERCONNECTED BY THE CONTRACTOR UNTIL APPROVAL FROM UTILITY IS RECEIVED.  
 9.ROOF ACCESS POINT SHALL BE LOCATED IN AREAS THAT DO NOT REQUIRE THE PLACEMENT OF GROUND LADDERS OVER OPENINGS SUCH AS WINDOWS OR DOORS, AND LOCATED AT STRONG POINTS OF BUILDING CONSTRUCTION WHERE THE ACCESS POINT DOES NOT CONFLICT WITH OVERHEAD OBSTRUCTIONS SUCH AS TREES, WIRES OR SIGNS.

10.PV ARRAY COMBINER / JUNCTION BOX PROVIDES TRANSITION FROM ARRAY WIRING TO CONDUIT WIRING.  
 11.RACKING SYSTEM SHALL BE LISTED TO UL 2703.  
 12.FIRE RATING OF EXISTING ROOF ASSEMBLY SHALL BE MAINTAINED WITH ADDITIONAL OF PHOTOVOLTAIC SYSTEM.

**SHEET CATALOG**

- PV-1** COVER SHEET
- PV-2** SITE PLAN-1
- PV-2.1** SITE PLAN-2
- PV-3** MOUNTING DETAILS
- PV-3.1** STRUCTURAL DETAILS
- PV-4** SINGLE LINE DIAGRAM
- PV-4.1** ELECTRICAL CALCULATIONS
- PV-5** PLACARDS
- SS** SPEC SHEETS

**Ron Bittler, PE**  
 Digitally signed by Ron Bittler, PE  
 DN: cn=Ron Bittler, PE, o, ou, email=rbittler@rbengineering.com, c=US  
 Date: 2023.08.15 14:12:34 -04'00'



STRUCTURAL  
 08.15.2023

STRUCTURAL REVIEW PROVIDED BY:  
 RONALD P. BITTLER, PE  
 RB ENGINEERING, INC. (C-2499)  
 168 QUADE DRIVE  
 CARY, NC 27513  
 919-677-9662  
 PROJECT #RB-239177

**PROJECT ID** AUR-83378

**DATE** 8/11/2023

**CREATED BY** VI

**SIGNATURE**

**COVER SHEET**  
**PV-1**



**SCOPE OF WORK**

(N) 7.920kW DC / 7.600kW AC ROOF MOUNT PV SYSTEM  
 (18) CERTAINTED SOLAR CT440HC11-06 440W (440W) MODULES  
 (1) TESLA SOLAR (7.6KW) INVERTER  
 (7) TESLA SOLAR SHUTDOWN DEVICE (MCI)  
 TOTAL ARRAY AREA = 422.91 SQ.FT  
 TOTAL ROOF AREA = 1897 SQ.FT  
 % ARRAY AREA IN ROOF = 22.29%

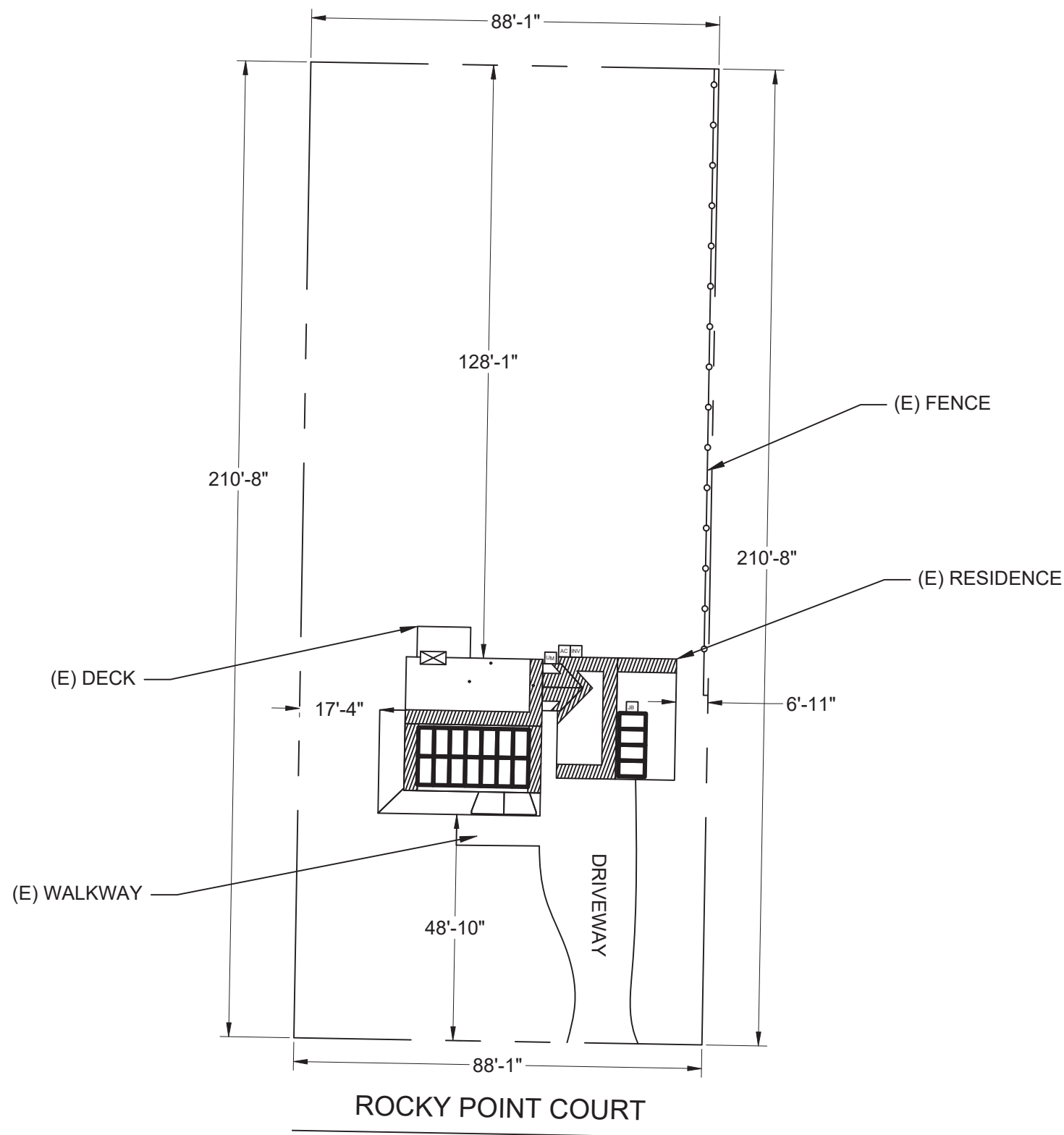
NOTE: NO GATE



**LEGEND**

-  SETBACK
-  PROPERTY LINE
-  FENCE LINE



SCALE: 1"=30'-0"

**CONTRACTOR INFORMATION**



YES SOLAR SOLUTIONS  
 ADDRESS: 202 NORTH DIXON AVENUE, CARY, NC 27513  
 PHONE NUMBER: (919) 375-0757

**CUSTOMER INFORMATION**

NAME: ADRIENNE TILLEY  
 ADDRESS: 175 ROCKY POINT COURT, FUQUAY-VARINA, NC 27526  
 COORDINATES: 35.526664, -78.852680  
 APN: 0644568676  
 7.920kW DC / 7.600kW AC ROOF MOUNT PV SYSTEM

PROJECT ID	AUR-83378
DATE	8/11/2023
CREATED BY	VI
SIGNATURE	

**SITE PLAN-1  
 PV-2**





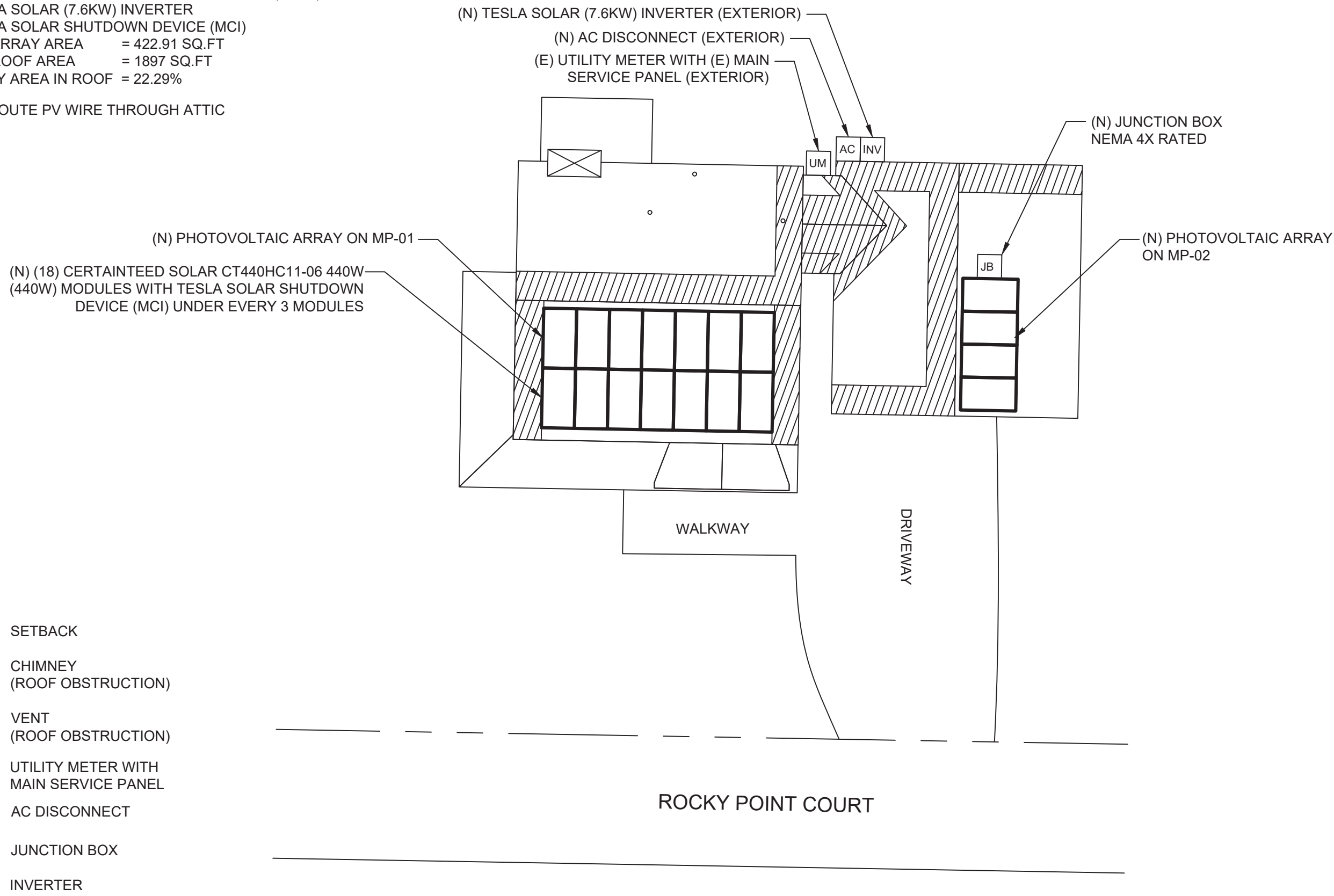

**SCOPE OF WORK**

(N) 7.920kW DC / 7.600kW AC ROOF MOUNT PV SYSTEM  
 (18) CERTAINTEED SOLAR CT440HC11-06 440W (440W) MODULES  
 (1) TESLA SOLAR (7.6KW) INVERTER  
 (7) TESLA SOLAR SHUTDOWN DEVICE (MCI)  
 TOTAL ARRAY AREA = 422.91 SQ.FT  
 TOTAL ROOF AREA = 1897 SQ.FT  
 % ARRAY AREA IN ROOF = 22.29%

NOTE: ROUTE PV WIRE THROUGH ATTIC



**LEGEND**

-  SETBACK
-  CHIMNEY (ROOF OBSTRUCTION)
-  VENT (ROOF OBSTRUCTION)
-  UTILITY METER WITH MAIN SERVICE PANEL
-  AC DISCONNECT
-  JUNCTION BOX
-  INVERTER



SCALE: 3/32" = 1'-0"

**CONTRACTOR INFORMATION**



YES SOLAR SOLUTIONS  
 ADDRESS: 202 NORTH DIXON AVENUE, CARY, NC 27513  
 PHONE NUMBER: (919) 375-0757

**CUSTOMER INFORMATION**

NAME: ADRIENNE TILLEY  
 ADDRESS: 175 ROCKY POINT COURT, FUQUAY-VARINA, NC 27526  
 COORDINATES: 35.526664, -78.852680  
 APN: 0644568676  
 7.920kW DC / 7.600kW AC ROOF MOUNT PV SYSTEM

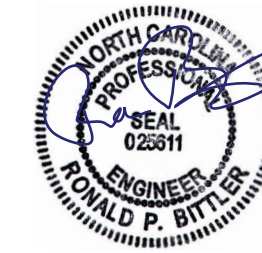

08.15.2023

<b>PROJECT ID</b>	AUR-83378
<b>DATE</b>	8/11/2023
<b>CREATED BY</b>	VI
<b>SIGNATURE</b>	

**SITE PLAN-2  
 PV-2.1**

WIND SPEED: 116 MPH AND SNOW LOAD: 15 PSF

S.NO	AZIMUTH	PITCH	NO. OF MODULES	ARRAY AREA (SQ.FT)	ROOF TYPE	ATTACHMENT	ATTACHMENT QUANTITY	ROOF EXPOSURE	FRAME TYPE	FRAME SIZE	FRAME SPACING	MAX ATTACHMENT SPACING	MAX OVER HANG
MP-01	181°	26°	14	328.93	COMPOSITION SHINGLE	SNAPNRACK ULTRA RAIL COMP KIT	28	ATTIC	PRE-FABRICATED TRUSSES	2" X 4"	24" O.C.	4'-0"	1'-6"
MP-02	91°	34°	4	93.98	COMPOSITION SHINGLE	SNAPNRACK ULTRA RAIL COMP KIT	9	ATTIC	PRE-FABRICATED TRUSSES	2" X 4"	24" O.C.	4'-0"	1'-6"

CONTRACTOR INFORMATION



YES SOLAR SOLUTIONS  
 ADDRESS: 202 NORTH DIXON AVENUE, CARY, NC 27513  
 PHONE NUMBER: (919) 375-0757

CUSTOMER INFORMATION

NAME: ADRIENNE TILLEY  
 ADDRESS: 175 ROCKY POINT COURT, FUQUAY-VARINA, NC 27526  
 COORDINATES: 35.526664, -78.852680  
 APN: 0644568676  
 7.920kW DC / 7.600kW AC ROOF MOUNT PV SYSTEM



08.15.2023

NOTE: PENETRATIONS ARE STAGGERED

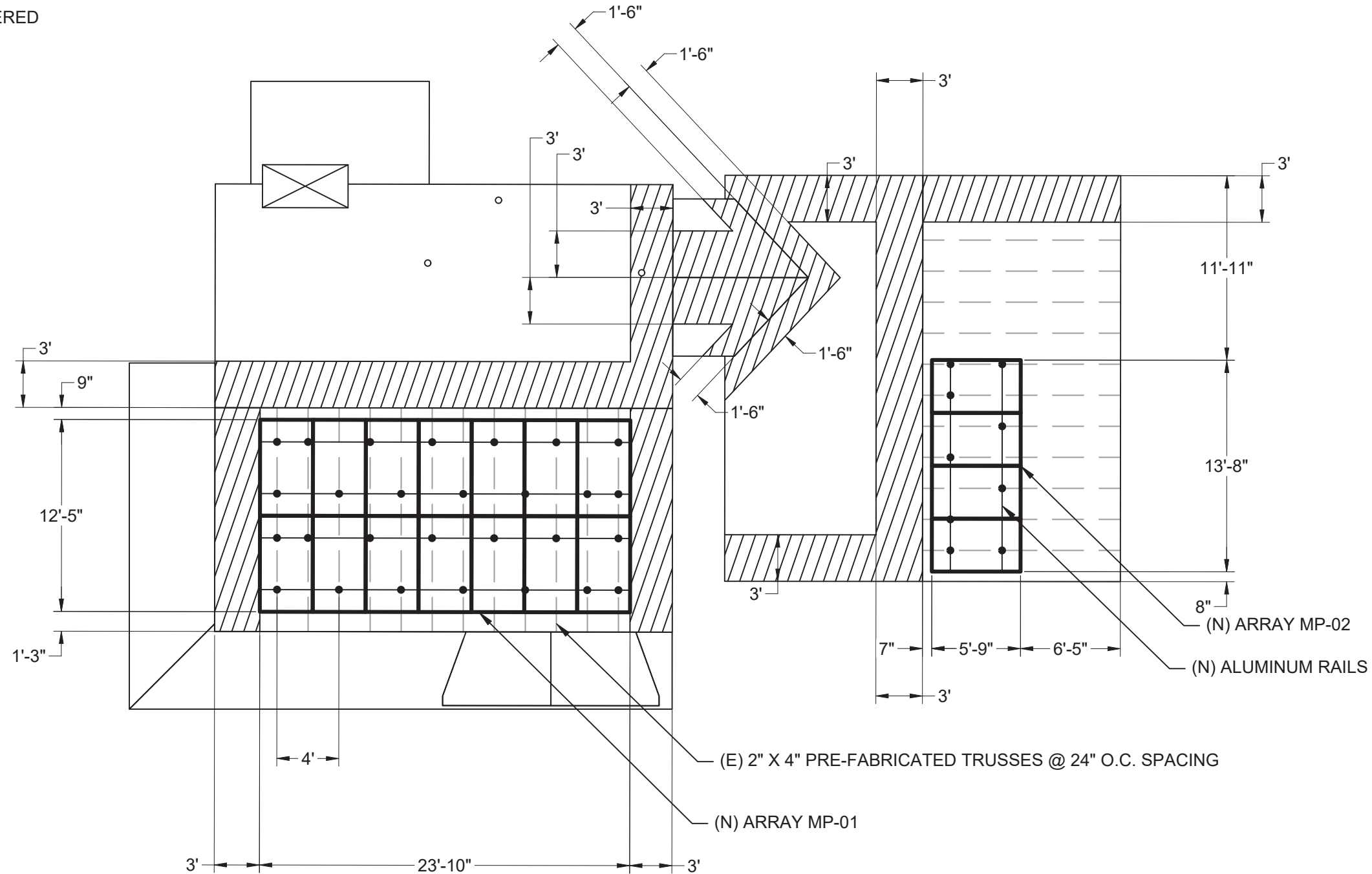

- LEGEND**
- SETBACK
  - MODULE
  - RAIL
  - ATTACHMENT
  - ROOF FRAME
  - CHIMNEY (ROOF OBSTRUCTION)
  - VENT (ROOF OBSTRUCTION)

SCALE: 1/8" = 1'-0"

PROJECT ID	AUR-83378
DATE	8/11/2023
CREATED BY	VI
SIGNATURE	

**MOUNTING DETAILS PV-3**

**CONTRACTOR INFORMATION**



YES SOLAR SOLUTIONS  
 ADDRESS: 202 NORTH DIXON AVENUE, CARY, NC 27513  
 PHONE NUMBER: (919) 375-0757

**CUSTOMER INFORMATION**

NAME: ADRIENNE TILLEY  
 ADDRESS: 175 ROCKY POINT COURT, FUQUAY-VARINA, NC 27526  
 COORDINATES: 35.526664, -78.852680  
 APN: 0644568676  
 7.920kW DC / 7.600kW AC ROOF MOUNT PV SYSTEM

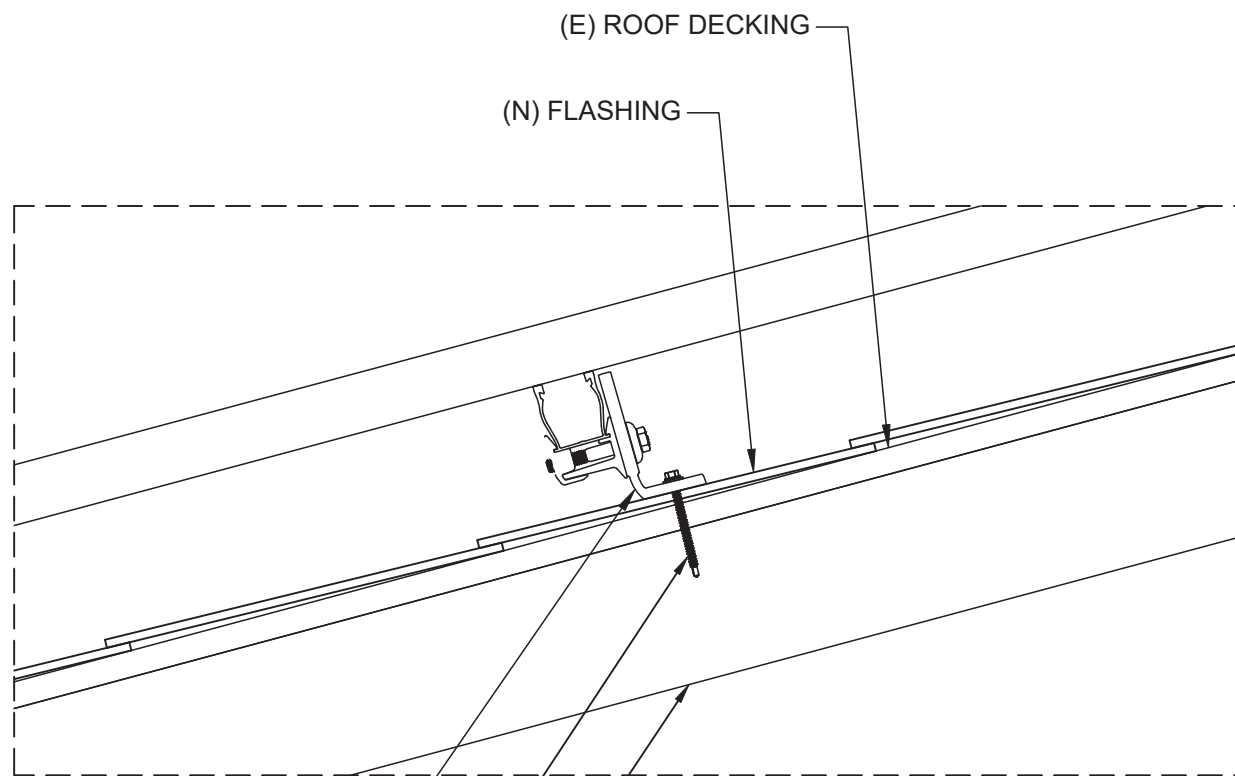
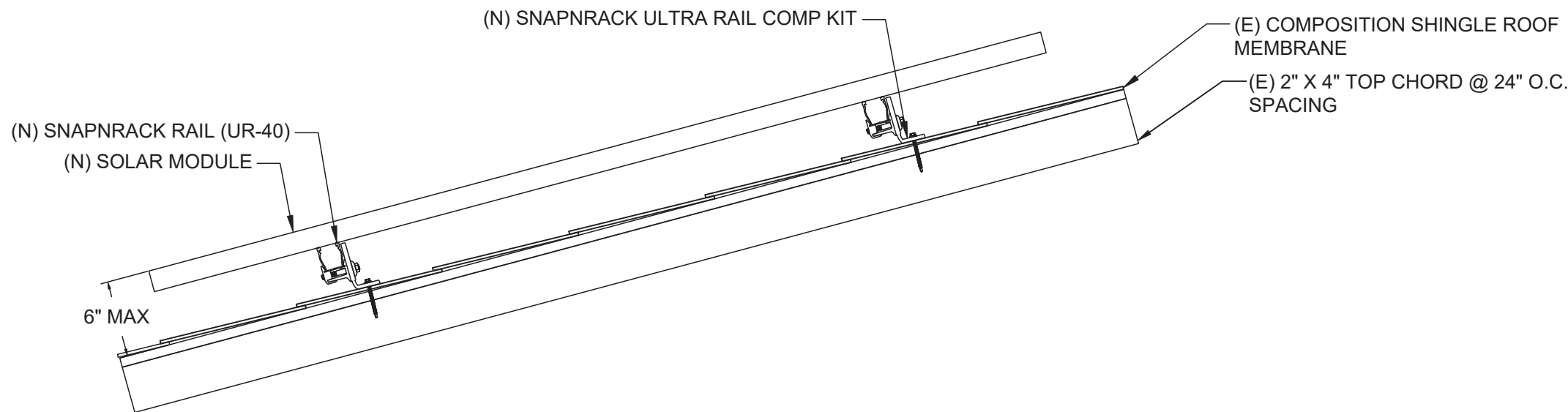

SCALE: NTS

**DEAD LOAD CALCULATIONS**

BOM	QUANTITY	LBS/UNIT	TOTAL WEIGHT (LBS)
MODULES	18	53.13	956.34
MID-CLAMP	30	0.17	5.10
END-CLAMP	12	0.3	3.60
RAIL LENGTH	126	0.42	52.92
SPLICE BAR	6	0.52	3.12
SNAPNRACK ULTRA RAIL COMP KIT	37	1.03	38.11
TOTAL WEIGHT OF THE SYSTEM (LBS)			1059.19
TOTAL ARRAY AREA ON THE ROOF (SQ. FT.)			422.91
WEIGHT PER SQ. FT.(LBS)			2.50
WEIGHT PER PENETRATION (LBS)			28.62

**PROJECT ID** AUR-83378

**DATE** 8/11/2023

**CREATED BY** VI

**SIGNATURE**

**STRUCTURAL DETAILS  
 PV-3.1**

MODULE SPECIFICATIONS	
MODEL	CERTAINEED SOLAR CT440HC11-06 440W (440W)
MODULE POWER @ STC	440W
OPEN CIRCUIT VOLTAGE:Voc	49.9V
MAX POWER VOLTAGE:Vmp	41.0V
SHORT CIRCUIT CURRENT:Isc	11.33A
MAX POWER CURRENT:Imp	10.74A
TEMPERATURE COEFFICIENT:Voc	-0.29%/°C
MODULE DIMENSIONS: L x W x H	82.56" x 40.98" x 1.61"
NO.OF MODULES	18

INVERTER-1 SPECIFICATIONS	
MODEL	TESLA SOLAR (7.6KW)
POWER RATING	7600W
MAX OUTPUT CURRENT	32A
CEC WEIGHTED EFFICIENCY	97.5%
MAX INPUT CURRENT	15A
MAX DC VOLTAGE	600V
NO.OF INVERTERS	1

RSD CHARACTERISTICS	
MODEL	TESLA SOLAR SHUTDOWN DEVICE (MCI)
NOMINAL INPUT DC CURRENT	12VDC
MAX INPUT SHORT CIRCUIT CURRENT	15VDC
MAX SYSTEM VOLTAGE	600ADC

**CONTRACTOR INFORMATION**



YES SOLAR SOLUTIONS  
 ADDRESS: 202 NORTH DIXON AVENUE, CARY, NC 27513  
 PHONE NUMBER: (919) 375-0757

**CUSTOMER INFORMATION**

NAME: ADRIENNE TILLEY  
 ADDRESS: 175 ROCKY POINT COURT, FUQUAY-VARINA, NC 27526  
 COORDINATES: 35.526664, -78.852680  
 APN: 0644568676  
 7.920kW DC / 7.600kW AC ROOF MOUNT PV SYSTEM

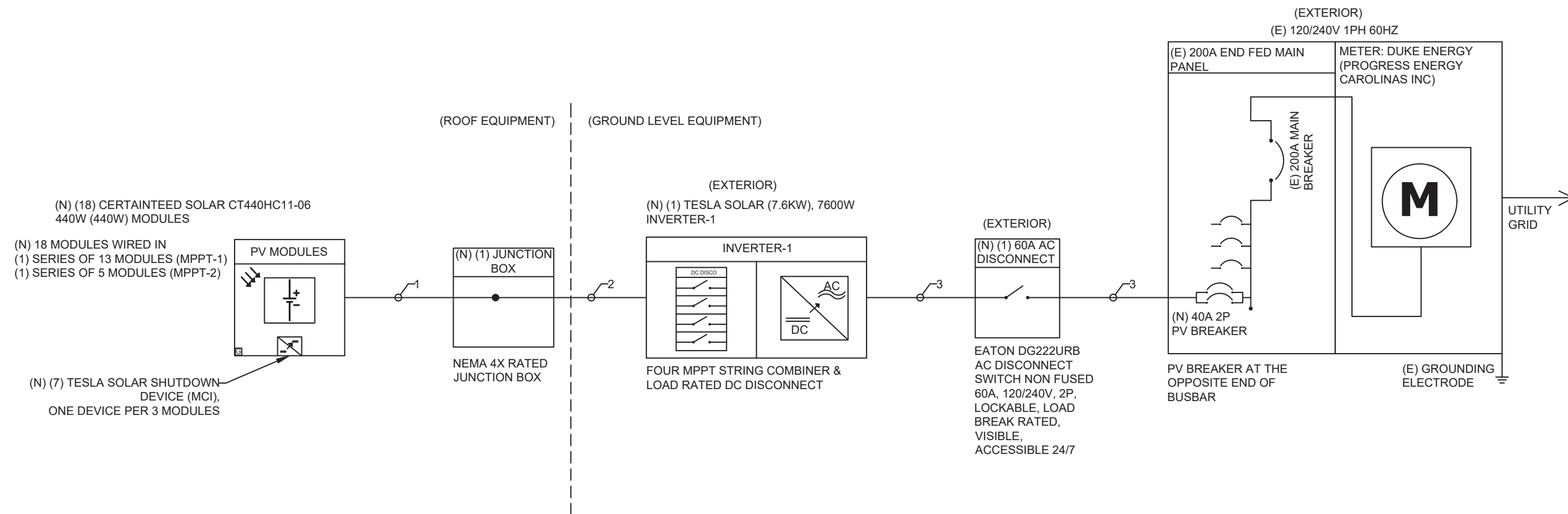

CONDUCTOR SCHEDULE				
TAG ID	CONDUIT SIZE	CONDUCTOR	NEUTRAL	GROUND
1	NONE	(4) 10 AWG PV WIRE	NONE	(1) 6 AWG BARE COPPER, EGC
2	3/4" EMT	(4) 10 AWG THHN/THWN-2, Cu	NONE	(1) 10 AWG THHN/THWN-2, EGC
3	3/4" EMT	(2) 8 AWG THHN/THWN-2, Cu	(1) 8 AWG THHN/THWN-2, Cu	(1) 10 AWG THHN/THWN-2, EGC

PROJECT ID	AUR-83378
DATE	8/11/2023
CREATED BY	VI
SIGNATURE	

**SINGLE LINE DIAGRAM PV-4**

SYSTEM CHARACTERISTICS	
DC SYSTEM SIZE	7920W
MAX OPEN CIRCUIT VOLTAGE	628V
OPERATING VOLTAGE	533V
MAX SHORT CIRCUIT CURRENT	28.32A
OPERATING CURRENT	21.48A

OCPD CALCULATION	
<b>ALLOWABLE BACKFEED:</b>	
MAIN PANEL RATING	= 200A
MAIN BREAKER RATING	= 200A
120% RULE:	= (MAIN PANEL RATING * 1.2) - MAIN BREAKER RATING
	= (200A * 1.2) - 200A
	= 240A - 200A
ALLOWABLE BACKFEED	= 40A
<b>INVERTER OVERCURRENT PROTECTION:</b>	
INVERTER OVERCURRENT PROTECTION	= INVERTER O/P CURRENT * CONTINUOUS LOAD (1.25)
	= 32 * 1.25
	= 40A
PV OVERCURRENT PROTECTION	= 40A
ALLOWABLE BACKFEED 40A ≥ 40A PV OVERCURRENT PROTECTION	
<b>THE DESIGNED INTERCONNECTION MEETS THE 705.12(B)(2)(3)(b) REQUIREMENTS.</b>	

**CONTRACTOR INFORMATION**



YES SOLAR SOLUTIONS  
 ADDRESS: 202 NORTH DIXON AVENUE, CARY, NC 27513  
 PHONE NUMBER: (919) 375-0757

**CUSTOMER INFORMATION**

NAME: ADRIENNE TILLEY  
 ADDRESS: 175 ROCKY POINT COURT, FUQUAY-VARINA, NC 27526  
 COORDINATES: 35.526664, -78.852680  
 APN: 0644568676  
 7.920kW DC / 7.600kW AC ROOF MOUNT PV SYSTEM

ELECTRICAL NOTES
<ol style="list-style-type: none"> <li>CONDUCTORS EXPOSED TO SUNLIGHT SHALL BE LISTED AS SUNLIGHT RESISTANT PER NEC 310.10(D).</li> <li>CONDUCTORS EXPOSED TO WET LOCATIONS SHALL BE SUITABLE FOR USE IN WET LOCATIONS PER NEC 310.10(C).</li> <li>MAXIMUM DC/AC VOLTAGE DROP SHALL BE NO MORE THAN 2%.</li> <li>ALL CONDUCTORS SHALL BE IN CONDUIT UNLESS OTHERWISE NOTED.</li> <li>BREAKER/FUSE SIZES PER NEC 240.</li> <li>AC EQUIPMENT GROUNDING CONDUCTOR SIZED PER NEC 250.122.</li> <li>AMBIENT TEMPERATURE CORRECTION FACTOR IS BASED ON NEC 310.15(B)(2)(a).</li> <li>MAX. SYSTEM VOLTAGE COEFFICIENT IS FROM MODULE MANUFACTURER OR NEC 690.7 WHEN MANUFACTURER COEFFICIENT UNAVAILABLE.</li> <li>CONDUCTORS ARE SIZED PER NEC TABLE 310.15(B)(16).</li> <li>CONDUIT SHALL BE INSTALLED MINIMUM 7/8" FROM ROOF SURFACE.</li> </ol>

WIRE SIZE CALCULATIONS	
AMBIENT TEMPERATURE @ 36°C	
<b>TAG 1: (DC)</b>	
REQUIRED CONDUCTOR AMPACITY (11.14 * 1.25 * 1.25)	= 17.40A
CORRECTED AMPACITY CALCULATION (0.91 * 1 * 40)	= 36.40A
17.40A < 36.40A (#10 AWG PV WIRE)	
<b>TAG 2: (DC)</b>	
REQUIRED CONDUCTOR AMPACITY (11.14 * 1.25 * 1.25)	= 17.40A
CORRECTED AMPACITY CALCULATION (0.91 * 0.8 * 40)	= 29.12A
17.40A < 29.12A (3/4" EMT, #10 AWG THHN/THWN-2, Cu)	
<b>TAG 3: (AC)</b>	
REQUIRED CONDUCTOR AMPACITY (32 * 1 * 1.25)	= 40.00A
CORRECTED AMPACITY CALCULATION (0.88 * 1 * 50)	= 44.00A
40.00A < 44.00A (3/4" EMT, #8 AWG THHN/THWN-2, Cu)	

**DC WIRE SIZING CALCULATIONS BASED ON FOLLOWING EQUATIONS**

**REQUIRED CONDUCTOR AMPACITY:**

$$I_{sc}(A) * \# \text{ OF PARALLEL STRINGS} = \text{MAX CURRENT PER 690.8(A)(1)} * 125\%$$

$$= \text{MAX CURRENT PER 690.8(B)(1)}$$

**CORRECTED AMPACITY CALCULATIONS:**

$$\text{DERATED CONDUCTOR AMPACITY PER 690.8(B)(2)} = \text{AMPACITY} * \text{TEMPERATURE DERATE FACTOR} * \text{CONDUIT FILL DERATE}$$

$$\text{DERATED CONDUCTOR AMPACITY CHECK : MAX CURRENT PER 690.8(B)(1)} < \text{DERATED CONDUCTOR AMPACITY}$$

**AC WIRE SIZING CALCULATIONS BASED ON FOLLOWING EQUATIONS**

**REQUIRED CONDUCTOR AMPACITY:**

$$\text{INVERTER OUTPUT CURRENT} * \# \text{ OF INVERTERS} = \text{MAX CURRENT PER 690.8(A)(3)} * 125\%$$

$$= \text{MAX CURRENT PER 690.8(B)(1)}$$

**CORRECTED AMPACITY CALCULATIONS:**

$$\text{DERATED CONDUCTOR AMPACITY PER 690.8(B)(2)} = \text{AMPACITY} * \text{TEMPERATURE DERATE FACTOR} * \text{CONDUIT FILL DERATE}$$

$$\text{DERATED CONDUCTOR AMPACITY CHECK : MAX CURRENT PER 690.8(B)(1)} < \text{DERATED CONDUCTOR AMPACITY}$$

**PROJECT ID** AUR-83378

**DATE** 8/11/2023

**CREATED BY** VI

**SIGNATURE**

**ELECTRICAL CALCULATIONS PV-4.1**



**WARNING**

**ELECTRIC SHOCK HAZARD**

TERMINALS ON BOTH LINE AND LOAD SIDES MAY BE ENERGIZED IN THE OPEN POSITION

DC VOLTAGE IS ALWAYS PRESENT WHEN SOLAR MODULES ARE EXPOSED TO SUNLIGHT

LABEL LOCATION  
AC DISCONNECT, POINT OF INTERCONNECTION  
PER CODE: NEC 690.13

**WARNING:PHOTOVOLTAIC POWER SOURCE**

LABEL LOCATION  
CONDUIT, INVERTER DC DISCONNECT  
PER CODE: NEC 690.31(G)(3)

**PHOTOVOLTAIC AC DISCONNECT**

LABEL LOCATION  
AC DISCONNECT, POINT OF INTERCONNECTION  
PER CODE: NEC 690.13(B)

**SOLAR PV SYSTEM EQUIPPED WITH RAPID SHUTDOWN**

TURN RAPID SHUTDOWN SWITCH TO THE "OFF" POSITION TO SHUT DOWN PV SYSTEM AND REDUCE SHOCK HAZARD IN THE ARRAY

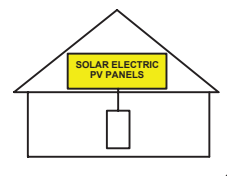

LABEL LOCATION  
AC DISCONNECT, INVERTER DC DISCONNECT, POINT OF INTERCONNECTION  
PER CODE: NEC 690.56(C)(1)(a)

**RAPID SHUTDOWN SWITCH FOR SOLAR PV SYSTEM**

LABEL LOCATION  
INVERTER DC DISCONNECT  
PER CODE: NEC 690.56(C)(3)

**PHOTOVOLTAIC SYSTEM AC DISCONNECT SWITCH**

RATED AC OPERATING CURRENT **32.00** AMPS AC  
AC NOMINAL OPERATING VOLTAGE **240** VAC

LABEL LOCATION  
AC DISCONNECT, POINT OF INTERCONNECTION  
PER CODE: NEC 690.54

**WARNING DUAL POWER SOURCE SECOND SOURCE IS PHOTOVOLTAIC SYSTEM**

LABEL LOCATION  
POINT OF INTERCONNECTION  
PER CODE: NEC 705.12(B)(3)

**WARNING POWER SOURCE OUTPUT CONNECTION DO NOT RELOCATE THIS OVER-CURRENT DEVICE**

LABEL LOCATION  
POINT OF INTERCONNECTION  
PER CODE: NEC 705.12(B)(2)(3)(b)

**INVERTER-1**

RATED MAXIMUM POWER-POINT CURRENT (I <sub>mp</sub> )	21.48	A
RATED MAXIMUM POWER-POINT VOLTAGE (V <sub>mp</sub> )	533	V
MAXIMUM SYSTEM VOLTAGE (V <sub>oc</sub> )	628	V
MAXIMUM CIRCUIT CURRENT (I <sub>sc</sub> )	28.32	A

LABEL LOCATION  
INVERTER DC DISCONNECT  
PER CODE: NEC 690.53

**CAUTION: MULTIPLE SOURCES OF POWER**



POWER TO THIS BUILDING IS ALSO SUPPLIED FROM THE FOLLOWING SOURCES WITH DISCONNECTS LOCATED AS SHOWN

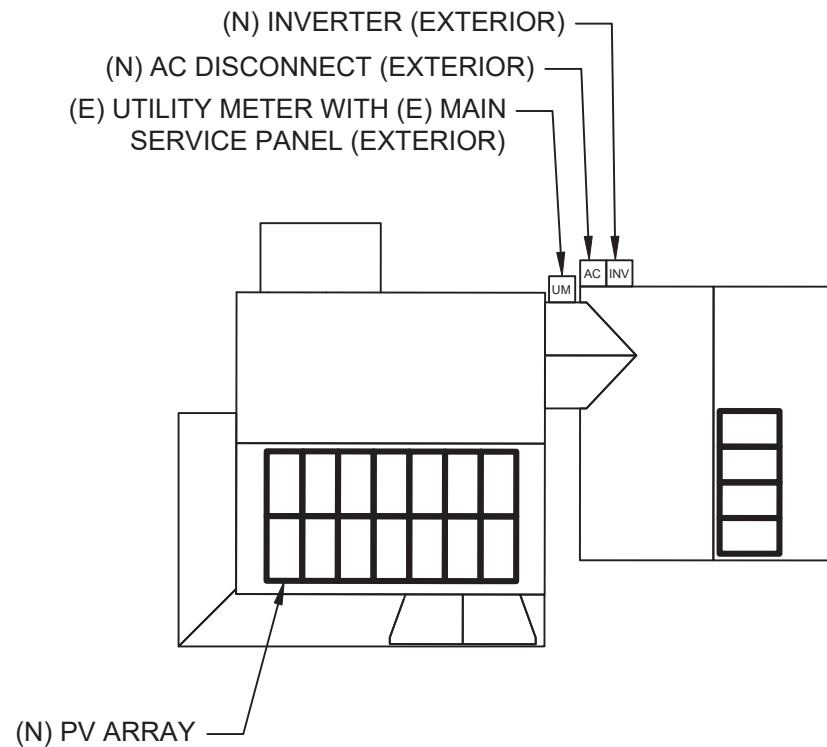

175 ROCKY POINT COURT, FUQUAY-VARINA, NC 27526

**NOTES**

1. PLACARDS SHALL MEET THE REQUIREMENTS OF ARTICLES 690 AND 705, UNLESS OTHERWISE SPECIFIED PER LOCAL AHJ REQUIREMENTS.
2. PLACARDS SHALL MEET THE REQUIREMENTS OF SECTION 110.21(B) AS REQUIRED AND SHALL COMPLY WITH ANSI Z535.4-2011, PRODUCT SAFETY SIGNS AND LABELS.
3. PLACARDS SHALL BE PERMANENTLY AFFIXED TO THE EQUIPMENT OR WIRING METHOD.
4. PLACARDS SHALL BE OF SUFFICIENT DURABILITY TO WITHSTAND THE ENVIRONMENT INVOLVED AND SHALL BE HANDWRITTEN.
5. PLACARDS SHALL NOT COVER EXISTING MANUFACTURER LABELS.
6. WARNING SIGNAGE TEXT SHALL BE MINIMUM 3/8" TALL.

LABEL LOCATION  
SERVICE PANEL  
PER CODE: NEC 705.10

**CONTRACTOR INFORMATION**



YES SOLAR SOLUTIONS  
ADDRESS: 202 NORTH DIXON AVENUE, CARY, NC 27513  
PHONE NUMBER: (919) 375-0757

**CUSTOMER INFORMATION**

NAME: ADRIENNE TILLEY  
ADDRESS: 175 ROCKY POINT COURT, FUQUAY-VARINA, NC 27526  
COORDINATES: 35.526664, -78.852680  
APN: 0644568676  
7.920kW DC / 7.600kW AC ROOF MOUNT PV SYSTEM

PROJECT ID AUR-83378

DATE 8/11/2023

CREATED BY VI

SIGNATURE

PLACARDS PV-5

CertainTeed Solar

# CT SERIES 144 HALF-CELL SOLAR MODULES

(430-440W)

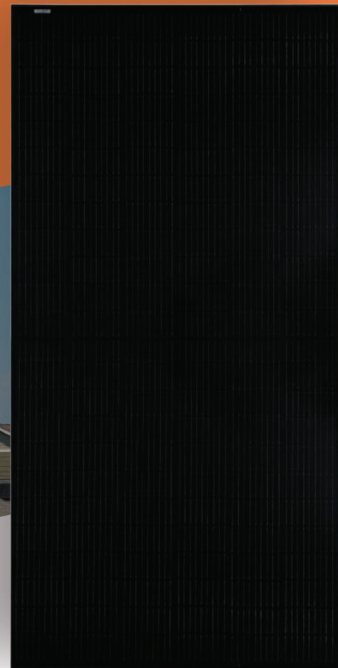

## Half-Cell Monocrystalline Type

- CT430HC11-06
- CT435HC11-06
- CT440HC11-06



## Features and Benefits

### High Quality / High Power

- Up to 440W with black backsheet
- UL listed (UL 61730)
- Positive power output tolerance

### Limited Warranty\*

- 25-year linear power output warranty

\*See CertainTeed's limited warranty for details

See reverse for product specifications

## Power Output Warranty

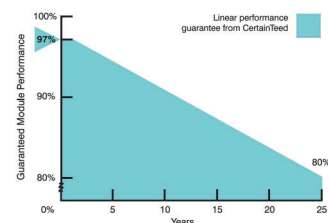

intertek

SAINT-GOBAIN



## Electrical Characteristics

		430W	435W	440W
Nominal Output (Pmpp)	W	430	435	440
Voltage at Pmax (Vmpp)	V	40.6	40.8	41.0
Current at Pmax (Impp)	A	10.60	10.67	10.74
Open Circuit Voltage (Voc)	V	49.5	49.7	49.9
Short Circuit Current (Isc)	A	11.19	11.26	11.33
Output Tolerance	W	-0 / +5		
No. of Cells & Connections		144 half-cells in series / 3 bypass diodes		
Maximum Series Fuse Rating		20A		
Cell Type		Half-cut Monocrystalline		
Module Efficiency	%	19.76	19.98	20.21
Temperature Coefficient of Pmpp	%/C	-0.36		
Temperature Coefficient of Voc	%/C	-0.29		
Temperature Coefficient of Isc	%/C	0.05		



## Mechanical Characteristics

Laminate	Glass: 3.2 high transmission, tempered, anti-reflective Encapsulant: POE Backsheet: Weatherproof film (Black or White)
Frame	Anodized aluminum (Black)
Junction Box	IP67/IP68
Output Cables	4 mm <sup>2</sup> (12AWG) PV Wire, Length 1.2m (39.37")
Connectors	Polarized MC4 compatible
Weight	24.01 kg (53.13 lbs)



## Operating Conditions

Nominal Operating Cell Temp.	44+/-2° C
Operating Temperature	-40 to 85° C
Maximum System Voltage	1,000V
Fire Performance	Class C / Type 1
Maximum Wind Load	210 mph Wind Speed (5400 Pa)
Maximum Snow Load	112 lbs/ft <sup>2</sup> (5400 Pa)



## Dimensions

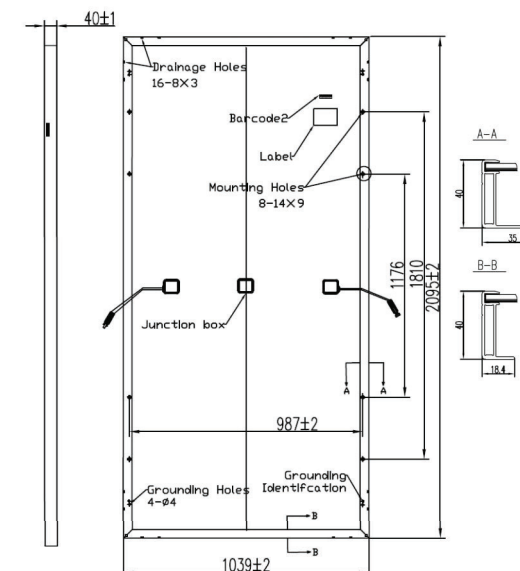

SAINT-GOBAIN

CertainTeed

CEILINGS • DECKING • FENCE • GYPSUM • INSULATION • RAILING • ROOFING • SIDING • TRIM  
20 Moores Road Malvern, PA 19355 Professional: 800-233-8990 Consumer: 800-782-8777 certainteed.com

© 3/21 CertainTeed, Printed in the USA, Code No. PV-01-024

## CONTRACTOR INFORMATION



YES SOLAR SOLUTIONS

ADDRESS: 202 NORTH DIXON AVENUE, CARY, NC 27513

PHONE NUMBER: (919) 375-0757

## CUSTOMER INFORMATION

NAME: ADRIENNE TILLEY

ADDRESS: 175 ROCKY POINT COURT, FUQUAY-VARINA, NC 27526

COORDINATES: 35.526664, -78.852680

APN: 0644568676

7.920kW DC / 7.600kW AC ROOF MOUNT PV SYSTEM

PROJECT ID AUR-83378

DATE 8/11/2023

CREATED BY VI

SIGNATURE

MODULE SPEC SHEET  
SS



TESLA

## SOLAR INVERTER

3.8 kW | 7.6 kW

Tesla Solar Inverter completes the Tesla home solar system, converting DC power from solar to AC power for home consumption. Tesla's renowned expertise in power electronics has been combined with robust safety features and a simple installation process to produce an outstanding solar inverter that is compatible with both Solar Roof and traditional solar panels. Once installed, homeowners use the Tesla mobile app to manage their solar system and monitor energy consumption, resulting in a truly unique ecosystem experience.

### KEY FEATURES

- Built on Powerwall 2 technology for exceptional efficiency and reliability
- Designed to integrate with Tesla Powerwall and Tesla App
- Wi-Fi, Ethernet, and cellular connectivity with easy over-the-air updates
- 3.8 kW and 7.6 kW models available

## SOLAR INVERTER

Tesla Solar Inverter provides DC to AC conversion and integrates with the Tesla ecosystem, including Solar Panels, Solar Roof, Powerwall, and vehicle charging, to provide a seamless sustainable energy experience.

### KEY FEATURES

- Integrated rapid shutdown, arc fault, and ground fault protection
- 2x the standard number of MPPTs for high production on complex roofs
- No neutral wire simplifies installation



### ELECTRICAL SPECIFICATIONS

OUTPUT (AC)	3.8 kW	7.6 kW
Nominal Power	3,800 W	7,600 W
Maximum Apparent Power	3,328 VA at 208 V 3,840 VA at 240 V	6,656 VA at 208 V 7,680 VA at 240 V
Maximum Continuous Current	16 A	32 A
Breaker (Overcurrent Protection)	20 A	40 A
Nominal Power Factor	1 - 0.85 (leading / lagging)	
THD (at Nominal Power)	< 5%	
INPUT (DC)		
MPPT	2	4
Input Connectors per MPPT	1-2	1-2-1-2
Maximum Input Voltage	600 VDC	
DC Input Voltage Range	60 - 550 VDC	
DC MPPT Voltage Range <sup>1</sup>	60 - 480 VDC	
Maximum Current per MPPT (I <sub>mp</sub> )	11 A	
Maximum Short Circuit Current per MPPT (I <sub>sc</sub> )	15 A	

### PERFORMANCE SPECIFICATIONS

Peak Efficiency <sup>2</sup>	97.5%	98.0%
CEC Efficiency <sup>2</sup>	97.5%	
Allowable DC/AC Ratio	1.4	
Customer Interface	Tesla Mobile App	
Internet Connectivity	Wi-Fi (2.4 GHz, 802.11 b/g/n), Ethernet, Cellular (LTE/4G) <sup>3</sup>	
AC Remote Metering Support	Wi-Fi (2.4 GHz, 802.11 b/g/n), RS-485	
Protections	Integrated arc fault circuit interrupter (AFCI), Rapid Shutdown	
Supported Grid Types	60 Hz, 240 V Split Phase 60 Hz, 208 V Wye	
Required Number of Tesla Solar Shutdown Devices per Solar Module	See <i>Solar Shutdown Device Requirements per Module</i> on page 3.	
Warranty	12.5 years	

<sup>1</sup>Maximum current.

<sup>2</sup>Expected efficiency pending final CEC listing.

<sup>3</sup>Cellular connectivity subject to network operator service coverage and signal strength.

### MECHANICAL SPECIFICATIONS

Dimensions	660 mm x 411 mm x 158 mm (26 in x 16 in x 6 in)
Weight	52 lb <sup>4</sup>
Mounting options	Wall mount (bracket)

<sup>4</sup>Door and bracket can be removed for a mounting weight of 37 lb.

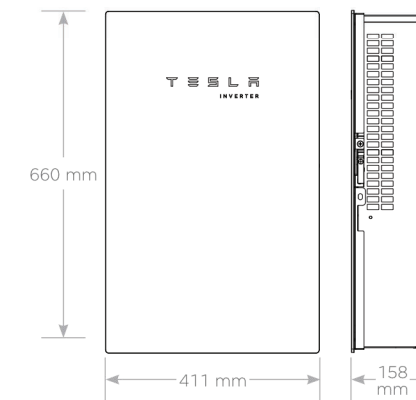

### ENVIRONMENTAL SPECIFICATIONS

Operating Temperature <sup>5</sup>	-30°C to 45°C (-22°F to 113°F)
Operating Humidity (RH)	Up to 100%, condensing
Storage Temperature	-30°C to 70°C (-22°F to 158°F)
Maximum Elevation	3000 m (9843 ft)
Environment	Indoor and outdoor rated
Enclosure Rating	Type 3R
Ingress Rating	IP55 (Wiring compartment)
Pollution Rating	PD2 for power electronics and terminal wiring compartment, PD3 for all other components
Operating Noise @ 1 m	< 40 db(A) nominal, < 50 db(A) maximum

<sup>5</sup>For the 7.6 kW Solar Inverter, performance may be de-rated to 6.2 kW at 240 V or 5.37 kW at 208 V when operating at temperatures greater than 45°C.

### COMPLIANCE INFORMATION

Grid Certifications	UL 1741, UL 1741 SA, IEEE 1547, IEEE 1547.1
Safety Certifications	UL 1699B, UL 1741, UL 1998 (US)
Emissions	EN 61000-6-3 (Residential), FCC 47CFR15.109 (a)

TESLA

NA 2021-1-14

TESLA.COM/ENERGY

## CONTRACTOR INFORMATION



YES SOLAR SOLUTIONS

ADDRESS: 202 NORTH DIXON AVENUE, CARY, NC 27513

PHONE NUMBER: (919) 375-0757

## CUSTOMER INFORMATION

NAME: ADRIENNE TILLEY

ADDRESS: 175 ROCKY POINT COURT, FUQUAY-VARINA, NC 27526

COORDINATES: 35.526664, -78.852680

APN: 0644568676

7.920kW DC / 7.600kW AC ROOF MOUNT PV SYSTEM

PROJECT ID AUR-83378

DATE 8/11/2023

CREATED BY VI

SIGNATURE

INVERTER SPEC SHEET  
SS

## SOLAR SHUTDOWN DEVICE

The Tesla Solar Shutdown Device is part of the PV system rapid shutdown (RSD) function in accordance with Article 690 of the applicable NEC. When paired with the Tesla Solar Inverter, the PVRSS is initiated by any loss of AC power.

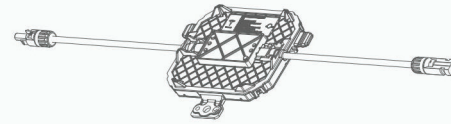

### ELECTRICAL SPECIFICATIONS

Nominal Input DC Current Rating ( $I_{MP}$ )	12 A
Maximum Input Short Circuit Current ( $I_{SC}$ )	15 A
Maximum System Voltage	600 V DC

### RSD MODULE PERFORMANCE

Maximum Number of Devices per String	5
Control	Power Line Excitation
Passive State	Normally open
Maximum Power Consumption	7 W
Warranty	25 years

### COMPLIANCE INFORMATION

Certifications	UL 1741 PVRSS PVRSA (Photovoltaic Rapid Shutdown Array)
----------------	--

### PVRSS

RSD Initiation Method	Loss of AC power
Compatible Equipment	Tesla Solar Inverter

### ENVIRONMENTAL SPECIFICATIONS

Ambient Temperature	-40°C to 50°C (-40°F to 122°F)
Storage Temperature	-30°C to 70°C (-22°F to 158°F)
Enclosure Rating	NEMA 4 / IP65

### MECHANICAL SPECIFICATIONS

Electrical Connections	MC4 Connector
Housing	Plastic
Dimensions	125 mm x 150 mm x 22 mm (5 in x 6 in x 1 in)
Weight	350 g (0.77 lb)
Mounting Options	ZEP Home Run Clip M4 Screw (#10) M8 Bolt (5/16") Nail / Wood screw

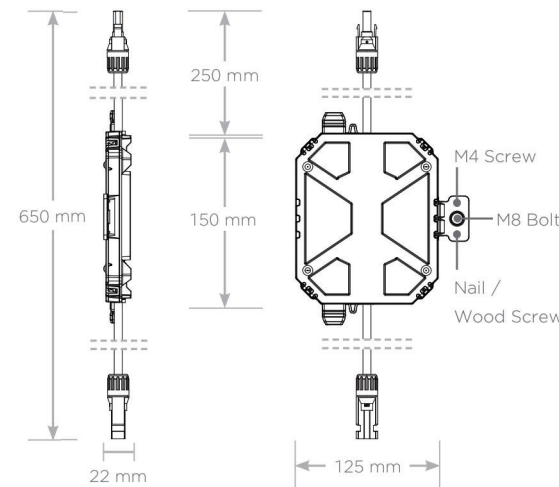

### SOLAR SHUTDOWN DEVICE REQUIREMENTS PER MODULE

The following modules have been certified as part of a PV Rapid Shutdown Array (PVRSA) when installed together with the Tesla Solar Inverter and Tesla Solar Shutdown Devices. See the Tesla Solar Inverter Installation Manual for guidance on installing Tesla Solar Inverter and Solar Shutdown Devices with other modules.

Brand	Model	Required Solar Shutdown Devices
Tesla	Solar Roof V3	1 Solar Shutdown Device per 10 modules
Hanwha	Q.PEAK DUO BLK-G5	1 Solar Shutdown Device per 3 modules
Hanwha	Q.PEAK DUO BLK-G6+	1 Solar Shutdown Device per 3 modules

## CONTRACTOR INFORMATION



YES SOLAR SOLUTIONS  
ADDRESS: 202 NORTH DIXON AVENUE, CARY, NC 27513  
PHONE NUMBER: (919) 375-0757

## CUSTOMER INFORMATION

NAME: ADRIENNE TILLEY  
ADDRESS: 175 ROCKY POINT COURT, FUQUAY-VARINA, NC 27526  
COORDINATES: 35.526664, -78.852680  
APN: 0644568676  
7.920kW DC / 7.600kW AC ROOF MOUNT PV SYSTEM

PROJECT ID AUR-83378

DATE 8/11/2023

CREATED BY VI

SIGNATURE

INVERTER SPEC SHEET  
SS

DESCRIPTION: <b>SNAPRACK, ULTRA RAIL COMP KIT</b>	DRAWN BY: mwatkins	
PART NUMBER(S): <b>SEE BELOW</b>	REVISION: <b>C</b>	

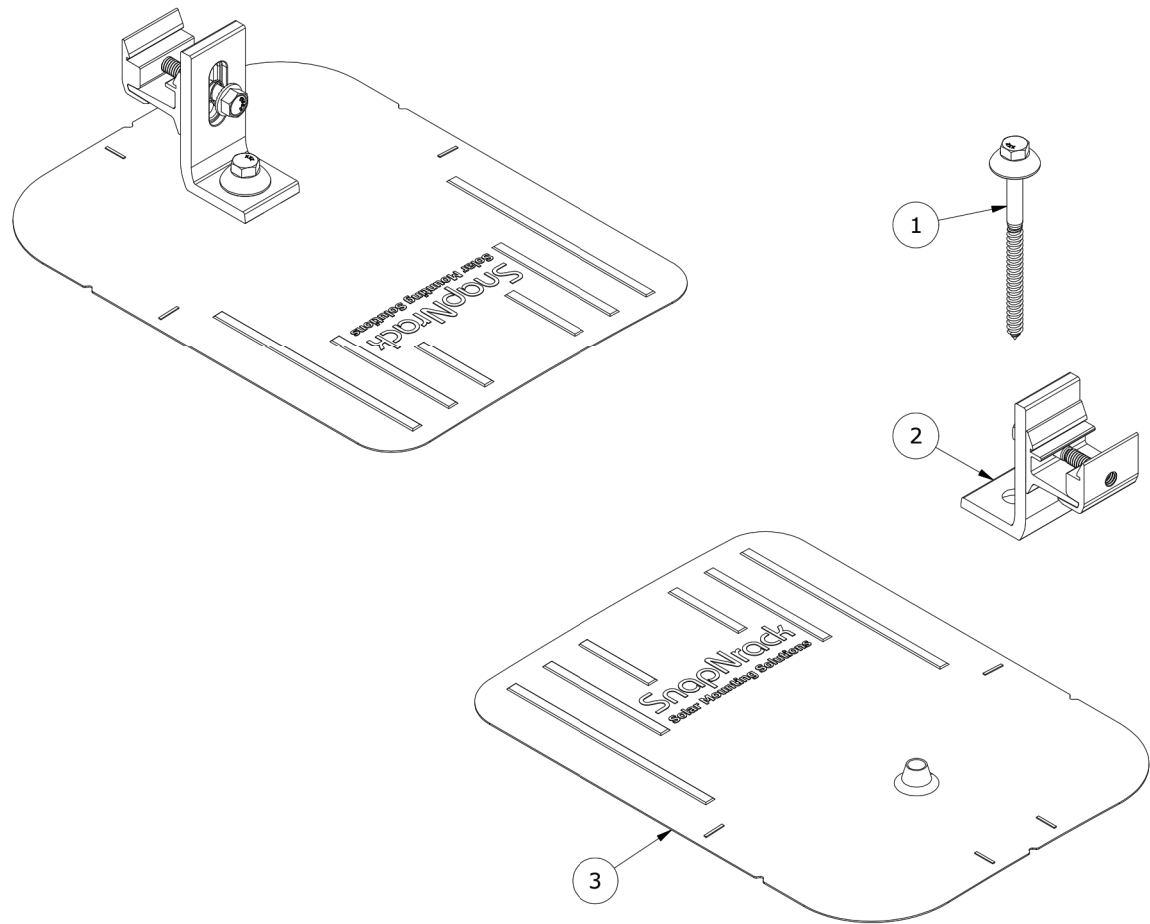

PARTS LIST			
ITEM	QTY	PART NUMBER	DESCRIPTION
1	1	242-92266	SNAPRACK, UMBRELLA LAG, TYPE 3, 4IN, SS
2	1	242-01219, 242-01220	SNAPRACK, ULTRA RAIL UMBRELLA L FOOT, SILVER / BLACK
3	1	232-01375, 232-01376, 232-01377	SNAPRACK, COMP FLASHING, 9IN X 12IN, SILVER / BLACK

MATERIALS:	6000 SERIES ALUMINUM, STAINLESS STEEL, RUBBER
DESIGN LOAD (LBS):	802 UP, 1333 DOWN, 356 SIDE
ULTIMATE LOAD (LBS):	2005 UP, 4000 DOWN, 1070 SIDE
TORQUE SPECIFICATION:	12 LB-FT
CERTIFICATION:	UL 2703, FILE E359313; WIND-DRIVEN RAIN TEST FROM UL SUBJECT 2582
WEIGHT (LBS):	0.79 - 1.03

DESCRIPTION: <b>SNAPRACK, ULTRA RAIL COMP KIT</b>	DRAWN BY: mwatkins	
PART NUMBER(S): <b>SEE BELOW</b>	REVISION: <b>C</b>	

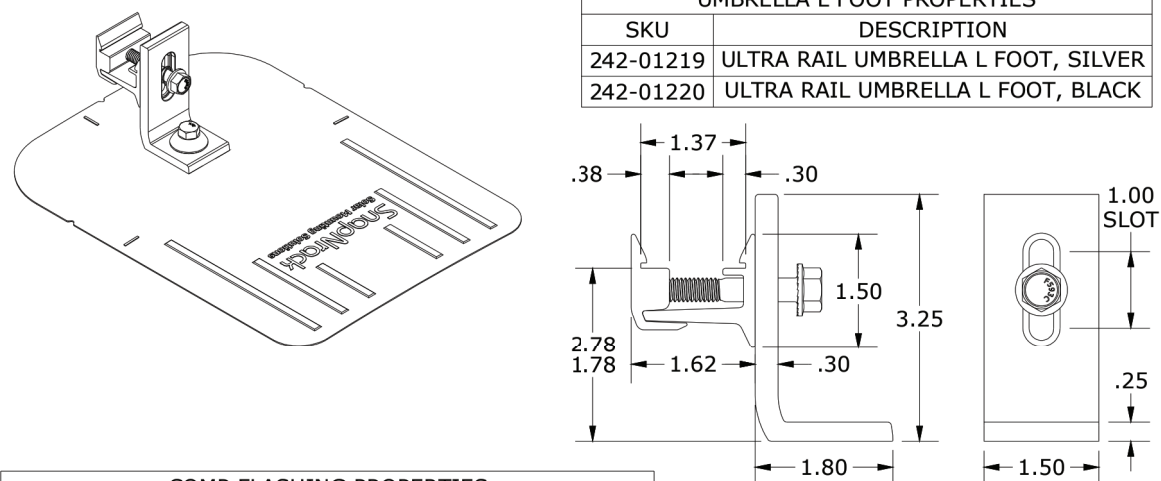

COMP FLASHING PROPERTIES	
SKU	DESCRIPTION
232-01375	COMP FLASHING, 9" X 12", BLACK ALUM
232-01376	COMP FLASHING, 9" X 12", SILVER ALUM
232-01377	COMP FLASHING, 9" X 12", BLACK GALVALUME

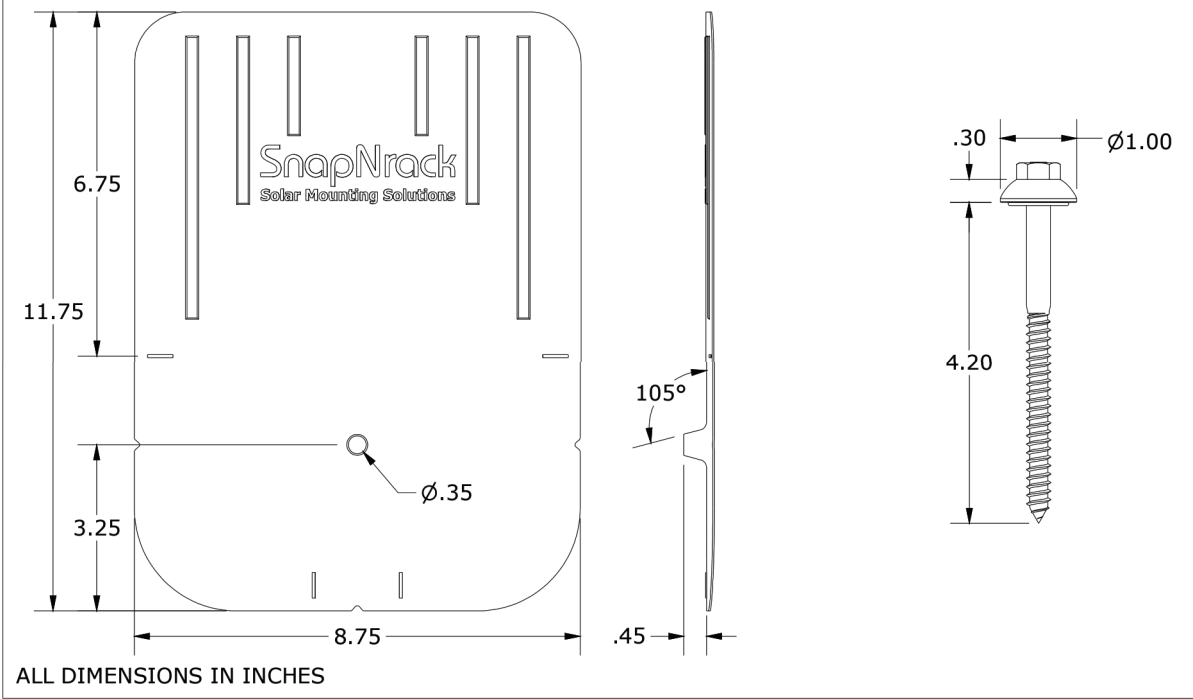

ALL DIMENSIONS IN INCHES

CONTRACTOR INFORMATION



YES SOLAR SOLUTIONS  
 ADDRESS: 202 NORTH DIXON AVENUE, CARY, NC 27513  
 PHONE NUMBER: (919) 375-0757

CUSTOMER INFORMATION

NAME: ADRIENNE TILLEY  
 ADDRESS: 175 ROCKY POINT COURT, FUQUAY-VARINA, NC 27526  
 COORDINATES: 35.526664, -78.852680  
 APN: 0644568676  
 7.920kW DC / 7.600kW AC ROOF MOUNT PV SYSTEM

PROJECT ID	AUR-83378
DATE	8/11/2023
CREATED BY	VI
SIGNATURE	

MOUNT SPEC SHEET  
 SS

# Ultra Rail

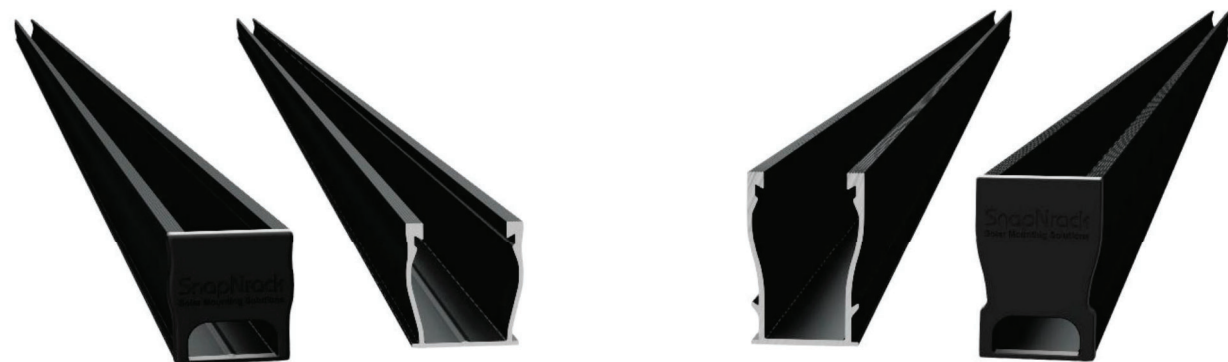

## The Ultimate Value in Rooftop Solar

 Industry leading Wire Management Solutions

 Mounts available for all roof types

 Single Tool Installation

 All SnapNrack Module Clamps & Accessories are compatible with both rail profiles

### Start Installing Ultra Rail Today

**RESOURCES** [snapnrack.com/resources](https://snapnrack.com/resources)  
**DESIGN** [snapnrack.com/configurator](https://snapnrack.com/configurator)  
**WHERE TO BUY** [snapnrack.com/where-to-buy](https://snapnrack.com/where-to-buy)

## SnapNrack Ultra Rail System

A sleek, straightforward rail solution for mounting solar modules on all roof types. Ultra Rail features two rail profiles; UR-40 is a lightweight rail profile that is suitable for most geographic regions and maintains all the great features of SnapNrack rail, while UR-60 is a heavier duty rail profile that provides a larger rail channel and increased span capabilities. Both are compatible with all existing mounts, module clamps, and accessories for ease of install.

### The Entire System is a Snap to Install

- New Ultra Rail Mounts include snap-in brackets for attaching rail
- Compatible with all the SnapNrack Mid Clamps and End Clamps customers love
- Universal End Clamps and snap-in End Caps provide a clean look to the array edge

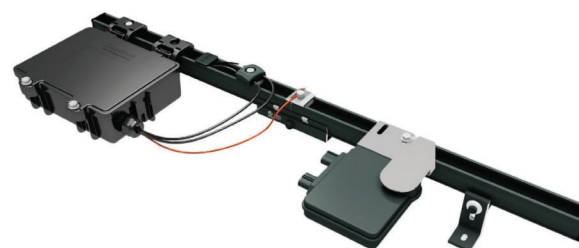

### Unparalleled Wire Management

- Open rail channel provides room for running wires resulting in a long-lasting quality install
- Industry best wire management offering includes Junction Boxes, Universal Wire Clamps, MLPE Attachment Kits, and Conduit Clamps
- System is fully bonded and listed to UL 2703 Standard

### Heavy Duty UR-60 Rail

- UR-60 rail profile provides increased span capabilities for high wind speeds and snow loads
- Taller, stronger rail profile includes profile-specific rail splice and end cap
- All existing mounts, module clamps, and accessories are retained for the same great install experience



## Quality. Innovative. Superior.

SnapNrack Solar Mounting Solutions are engineered to optimize material use and labor resources and improve overall installation quality and safety.

877-732-2860 [www.snapnrack.com](https://www.snapnrack.com) [contact@snapnrack.com](mailto:contact@snapnrack.com)

© 2019 by SnapNrack Solar Mounting Solutions. All rights reserved.

### CONTRACTOR INFORMATION



YES SOLAR SOLUTIONS  
ADDRESS: 202 NORTH DIXON AVENUE, CARY, NC 27513  
PHONE NUMBER: (919) 375-0757

### CUSTOMER INFORMATION

NAME: ADRIENNE TILLEY  
ADDRESS: 175 ROCKY POINT COURT, FUQUAY-VARINA, NC 27526  
COORDINATES: 35.526664, -78.852680  
APN: 0644568676  
7.920kW DC / 7.600kW AC ROOF MOUNT PV SYSTEM

PROJECT ID	AUR-83378
DATE	8/11/2023
CREATED BY	VI
SIGNATURE	

RAIL SPEC SHEET  
SS