



Ford Charge Station Pro

Installation Guide

80 AMP WALLBOX

Electric Vehicle Charging Station

Ford Customer Support

In the US: Call 1 (800) 392-3673

In Canada: Call 1 (800) 565-3673

Wi-Fi Password

Ford Station Pro Dimensions

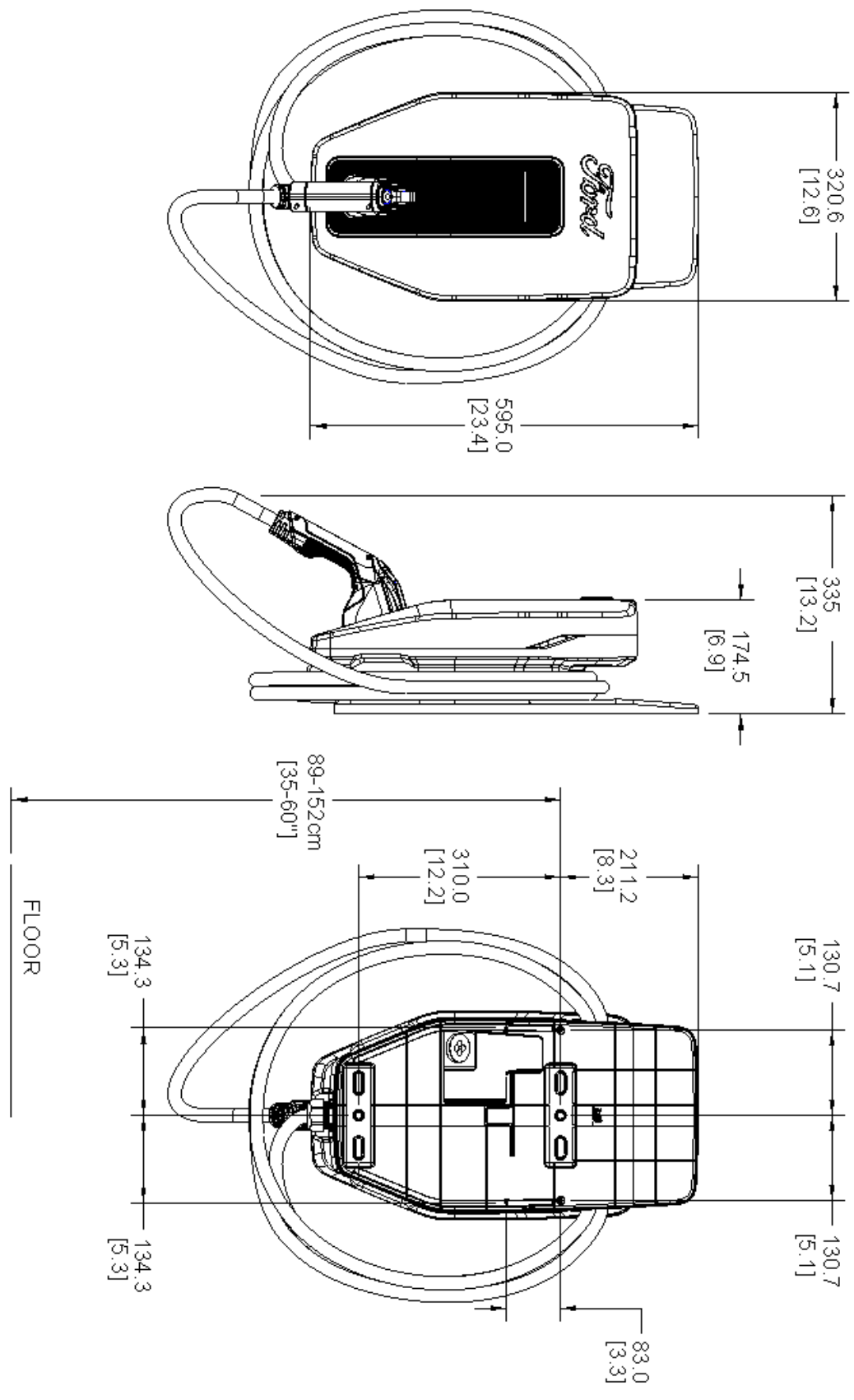

Important Safety Instructions

- a) **SAVE THESE INSTRUCTIONS-** This manual contains important instructions for model NL38-10C823-AA that shall be followed during installation, operation and maintenance
- b) Wiring information

Terminal	Amperage	Wire Size AWG, 90°C	Torque in-lbs. (Nm)
A/L1, B/L2[N]	80	3	60 in-lbs. (6.8 Nm)
Earth		6	35 in-lbs. (4 Nm)
DC+, DC-	34	8	35 in-lbs. (4 Nm)
RS-485 Terminals		18	3 in-lbs. (.3 Nm)

- c) To reduce the risk of electrical shock, and to ensure the safe installation and operation of this equipment, the following safety symbols appear throughout this document to indicate dangerous conditions and important safety instructions

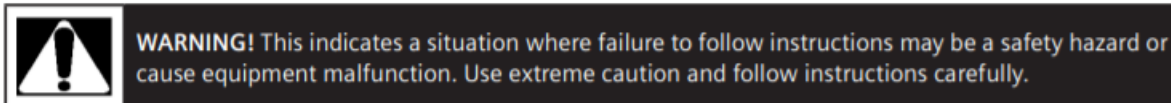
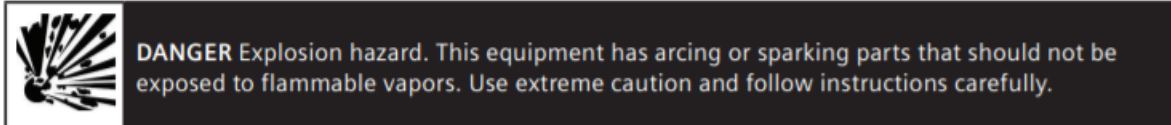
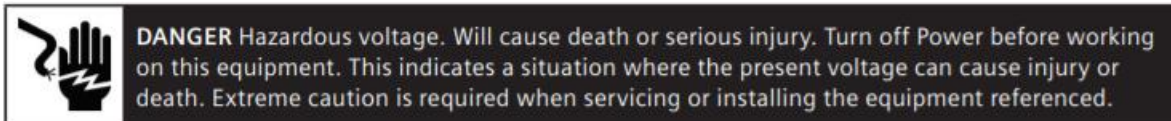

Indicates the connection point for a ground conductor

- d) The maximum rated ambient temperature of this device is 113°F (45°C)
- e) Use 3 AWG, 90°C copper wire only for AC connections (A/L1 and B/L2[N])
- f) Use 16 AWG, 600v copper wire for 2 position connector (Dark Start).
- g) **CAUTION** to reduce risk of fire, connect only to a circuit with 100 amperes maximum branch circuit overcurrent protection in accordance with the National Electric Code, ANSI/NFPA 70.
- h) **GROUNDING INSTRUCTIONS-** This unit is to be connected to a grounded, metal, permanent wiring system; or an equipment-grounding conductor is to be run with circuit conductors and connected to an equipment-grounding terminal.
- i) This equipment should be installed at least 18 inches above floor or ground level.
- j) To maintain Type 4 enclosure rating, use Listed conduit fitting rated Type 4 or 4X.

Table of Contents

Ford Customer Support.....	1
Wi-Fi Password.....	1
Ford Station Pro Dimensions	2
Important Safety Instructions	3
Table of Contents.....	4
Installation Method Checklist	5
Supplied Equipment.....	6
Equipment List – What’s Needed.....	6
Open Charger – Prepare the Charger for Mounting	7
Mount Bracket	8
Mount Charger Base to Wall Bracket.....	9
HVDC Wiring – Left Entry	10
HVDC Wiring – Right Entry.....	11
Standard Wiring – Residential Installation – Rear Entry.....	12
Alternate Wiring – Residential Installation – Left Entry	13
Alternate Wiring – Residential Installation – Right Entry	14
Set Maximum Current Switch	15
Close the Charger.....	16
Operating Instructions	17
LED Status	18
Maintenance.....	18
General exterior maintenance	18
Appendix A – Conduit Drilling Template (Compatible with suggested gland/conduit configurations).....	19

Installation Method Checklist

Installation Method Checklist		
	DO NOT DRILL ANY HOLES IN CHARGER UNTIL METHOD IS DETERMINED	✓
1	Minimum 100 Amp Service Available for Standard 80 Amp Installation If Customer does not have 100 Amp available, refer to Amp Setting Switch to adjust Charger Amperage (Listed in Table of Contents)	
2	Standard Mounting to Interior Stud Wall (Hardware Included)	
3	Exterior Mounting to Non-Standard Wall (Concrete, Brick, Non-wood surfaces) Non-Standard Mounting hardware not supplied – Alternate Hardware chosen must support 100 Lbs.	
4	Mounting requiring watertight Glands (Conduit Mounting Hardware not supplied). Rigid Conduit is preferred installation method.	
5	AC Rear Inlet Wiring Method (Standard – Mounting Hole supplied in Charger) NOTE: Remove Rear Plug prior to attaching Charger to Mounting Bracket if this method is chosen	
6	AC Left Inlet Wiring Method (Alternate – Requires Drilling for 1" Trade Size Conduit) 1" Meyers Hub (Type 4 or 4X) requires 1-3/8" Hole (Follow Hub manufacturer's instructions) Conduit Mounting Hardware not supplied	
7	AC Right Inlet Wiring Method (Alternate – Requires Drilling for 1" Trade Size Conduit) 1" Meyers Hub (Type 4 or 4X) requires 1-3/8" Hole (Follow Hub manufacturer's instructions) Conduit Mounting Hardware not supplied	
8	HVDC Inverter (If customer has Inverter – Requires Drilling for 3/4" Trade Size Conduit either Left or Right) 3/4" Meyers Hub (Type 4 or 4X) requires 1-1/8" Hole (Follow Hub manufacturer's instructions) Conduit Mounting Hardware not supplied	
9	HVDC Inverter Inlet Left Wiring Method	
10	HVDC Inverter Inlet Right Wiring Method	

Supplied Equipment

Equipment
1 – 80A Charger
1 – Mounting Bracket
Hardware Kit
2 – 3/8" x 2-1/2" LG Flange Hex Head Lag Bolts
6 – (T20) Torx-head Dog Point Screws – M4 x 0.7 x 16 mm (2 extra)
1 – Connector – 3 position (Communications)
1 – Connector – 2 position (Dark Start – Battery Backup)

Equipment List – What's Needed

TOOLS
Certified Electrician
7/32" Drill Bit
Stud Finder
Level
CAT I – 600v Multimeter (minimum)
5/32" Hex Head Bit or Allen Wrench
9/16" Wrench or Socket Wrench
Small Flat head-Screw Bit (For RS-485 Connectors)
Torx Head (T20) Bit
Torque Driver
Step Drill Bit – (If needed for Conduit Connectors – 1-1/8" - 1-3/8" holes)
ADDITIONAL ITEMS (Not Included)
1- 3/4" Conduit Connector (see Installation Checklist If Needed)
1- 1" Conduit Connector (see Installation Checklist If Needed)
3 AWG – 90°C Copper wire should be used
NOTE: Wire must have a temperature rating of 90° C or higher for AC Connections (A/L1 and B/L2[N])
80A charger requires a 100 A non-GFCI breaker.
HVDC Wire – 8 AWG 90°C, 600V
Dark Start Wire – 16 AWG, 600V to comply with NEC300.3©(1).
Communication Wire – 18 AWG, 600V to comply with NEC300.3©(1).

Open Charger – Prepare the Charger for Mounting

OPEN CHARGER COVER	
A	The unit can be left in box to protect from any scratches or debris. Using both hands, Place thumbs on inner Black Cover and fingers into Hand Pulls located on sides of unit to unsnap and remove the decorative cover and place aside. DO NOT PLACE COVER FACE DOWN ON ANY ABRASIVE SURFACES.
B	Remove the (9) T-20 Torx-Head Dog Point Screws – M4 x 0.7 x 16 mm. Retain Screws and Cover for Replace Cover Step.
C	NOTE: If AC Wiring method chosen is Standard Rear Entry. Pierce wire though Rear Plug prior to attaching Charger to Mounting Bracket.

QTY	KIT ITEM
2	(T-20) Torx-head Dog Point Screws – M4 x 0.7 x 16 mm Extra screws if you lose one
TOOLS NEEDED	
1	Torx-head (T20) Torx driver

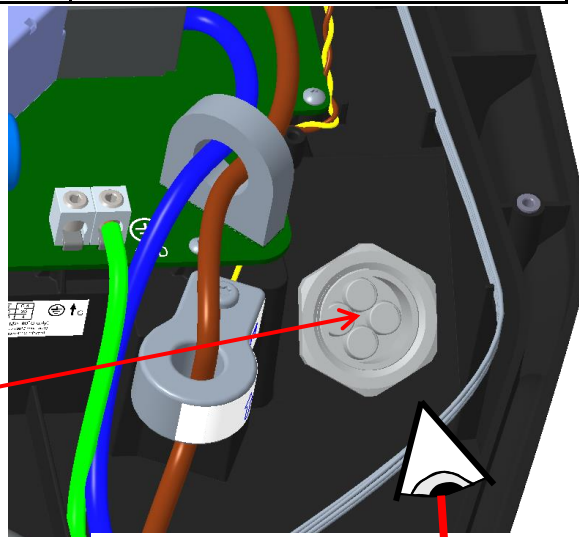

Pierce wires through Plug if using AC Rear Entry

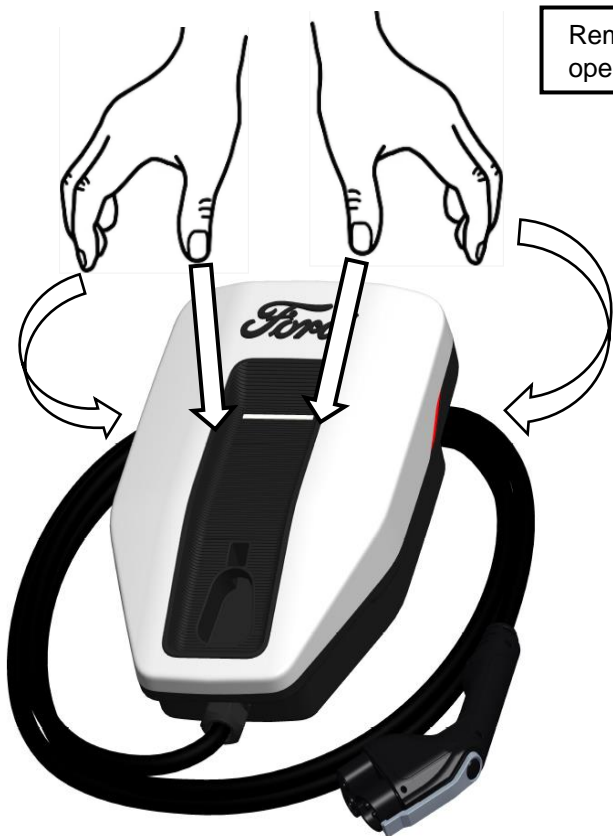

REMOVE DECORATIVE COVER

Remove (9) screws to open Structural Cover

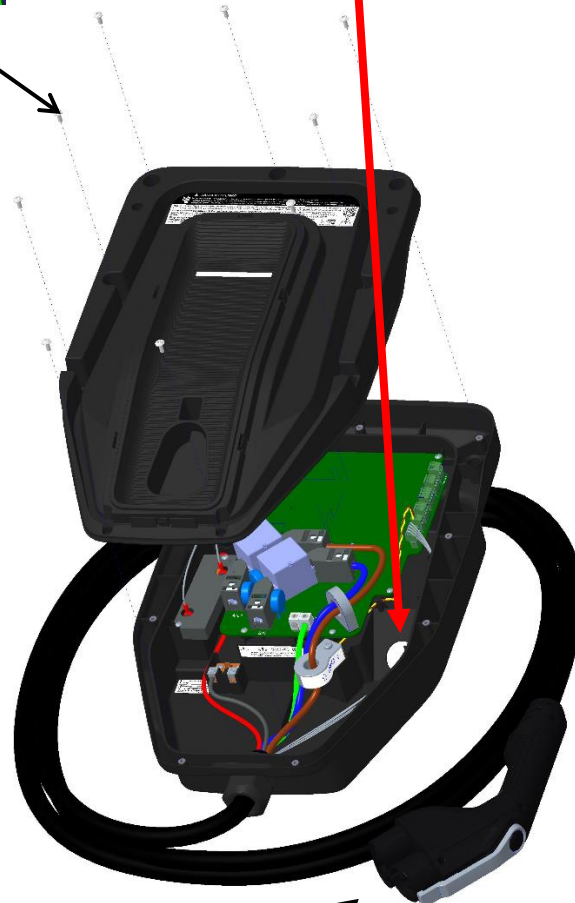

Protect Cable and Coupler from scratches and debris

OPEN CHARGER

Mount Bracket

MOUNT BRACKET TO WALL	
A	Locate Stud with Stud Finder
B	Verify Gang Box is installed on right side of stud. Top Bracket hole should be between 35-60" from floor. See page 2 dimensional graphic. No Gang Box needed if AC Conduit Installation
C	Line up Mounting Bracket opening with Gang Box as shown, use Level to align Bracket and mark the two center mounting holes.
D	Use Drill with 7/32" bit to drill pilot into stud.
E	Align Bracket on wall and Install (2) 3/8" x 2-1/2" Hex Lag Bolts into wall using 9/16" Socket to tighten to wall. (See Figure below).

QTY	KIT ITEM
1	MOUNTING BRACKET
2	3/8" X 2-1/2" HEX LAG BOLT
TOOLS NEEDED	
STUD FINDER	
LEVEL	
Drill with 7/32" Pilot Bit	
9/16" SOCKET	

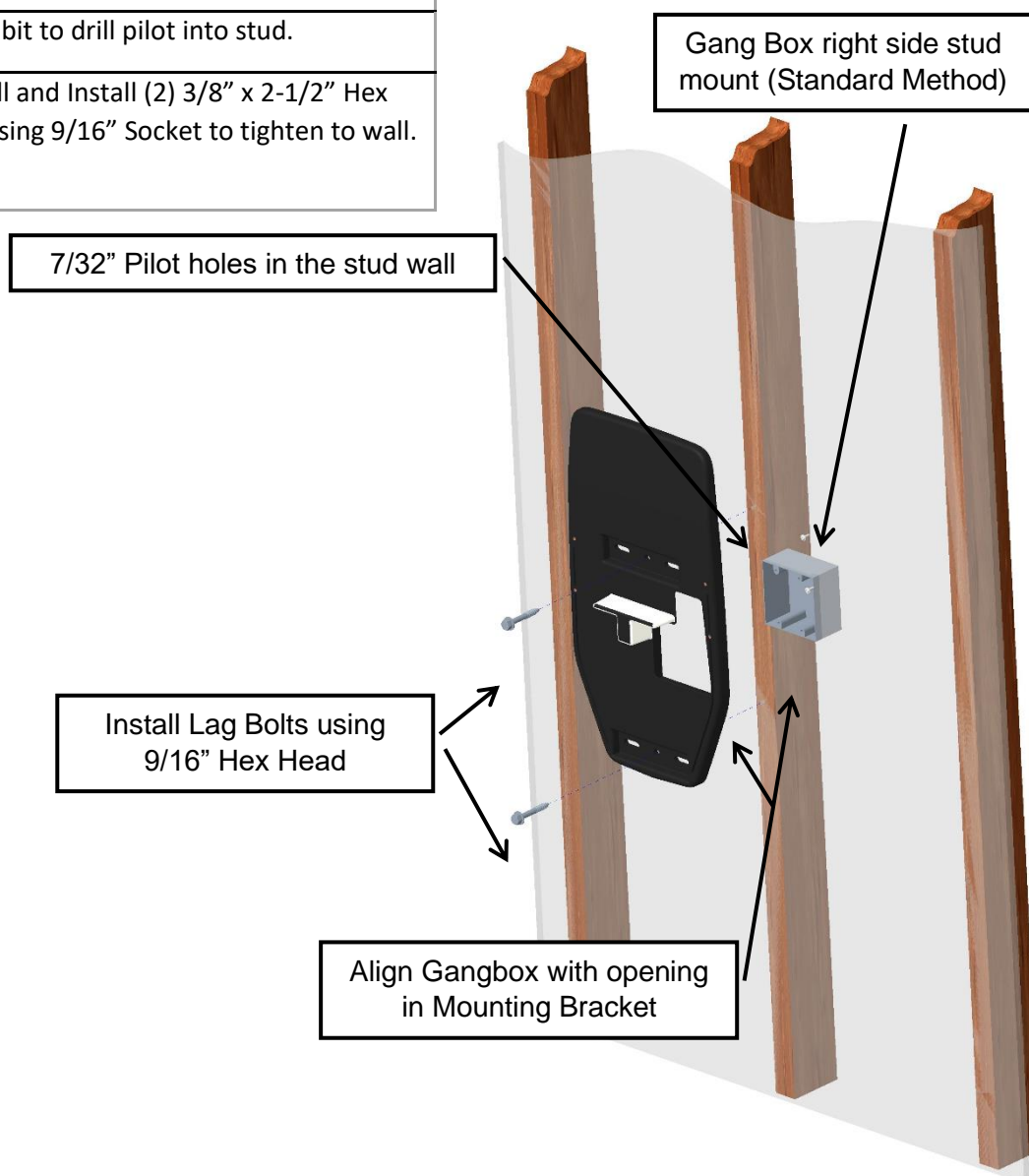

Mount Charger Base to Wall Bracket

MOUNT CHARGER BASE TO WALL BRACKET	
A	Slide the base onto the interlocking T-feature and align unit with base. Set Coupler aside while mounting Charger base.
B	Using the (4)-M4 x 0.7 x 16mm Mounting Screws, attach the unit to the base securely. Torque to 10 in-lbs. (1.1 Nm)
C	Wrap Cable with Coupler around Charger using Designated Cable Storage Feature

QTY	KIT ITEM
4	Torx-head Screws – M4 x 0.7 x 16 mm
TOOLS NEEDED	
	Torx Head (T20) Driver Bit
	Torque Driver

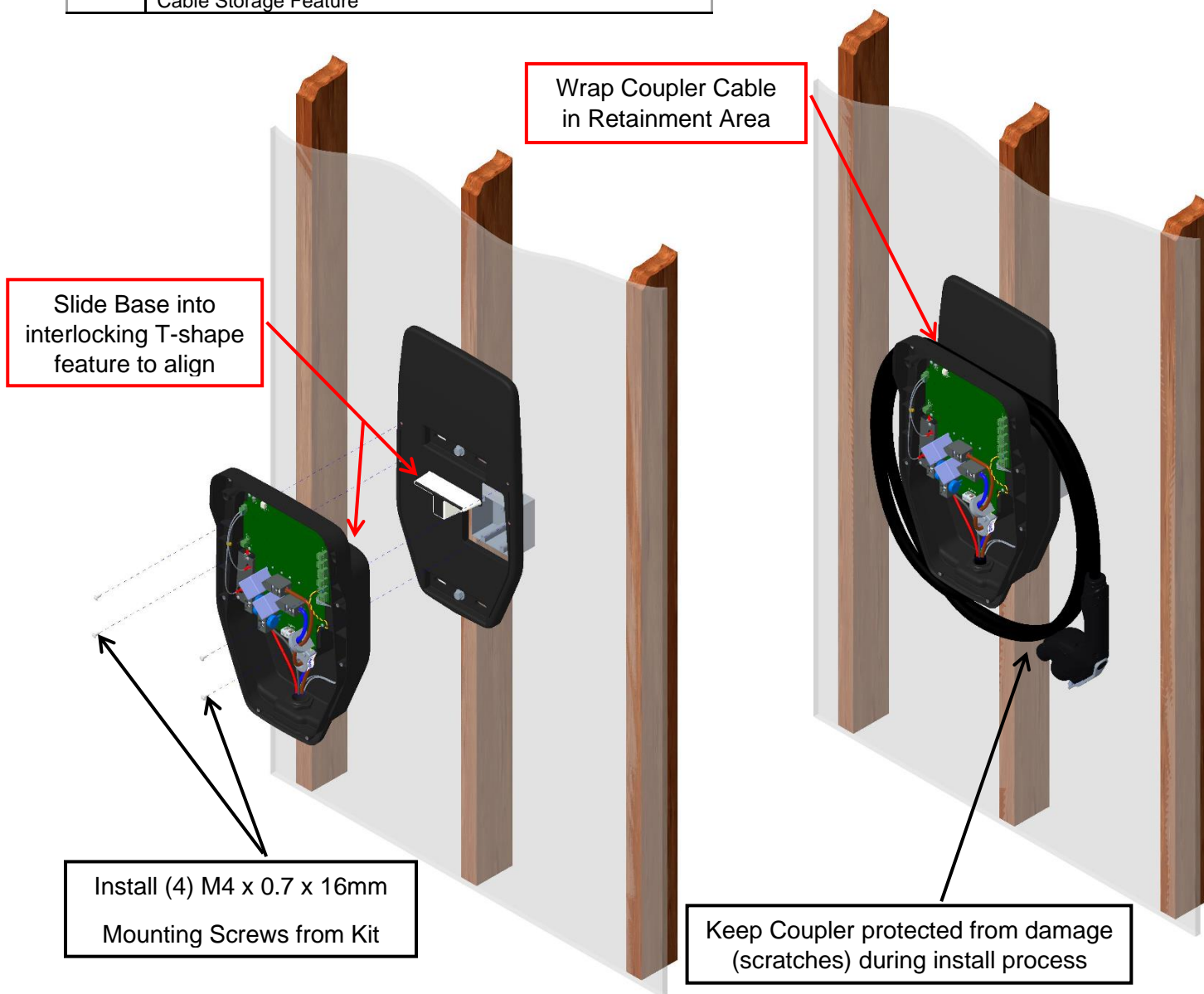

Mount Charger

HVDC Wiring – Left Entry



DANGER Hazardous voltage. Will cause death or serious injury. Turn off power before working on this equipment. This indicates a situation where the present voltage could cause injury or death. Extreme caution is required when servicing or installing the equipment referenced.

NOTE: Charger will need to be mounted on the bracket to hardwire the device. HVDC wiring first is preferred method.

HVDC Wiring – Route HVDC over EVSE Cable and prior to AC wiring.

A	Use kit-supplied wire drilling template to align and use stepper drill to drill appropriate size hole for 3/4" Conduit connector (Standard hole 1-1/8"). Clean all drill debris from unit. Install Conduit and Connector per manufacturer's installation instruction and route wires into enclosure.
B	HVDC – Detach spade terminal protruding from the DC Fuse Cover. Use Torx Driver to remove DC Fuse Cover. Route 8 AWG – 90°C 600V Copper wires through the conduit and connect Positive wire to Fuse and Negative wire to terminal as shown. Tighten connections to 35 in-lbs. (4 Nm) using a Flat Head Bit. Replace DC Fuse Cover.
C	Dark Start (Battery Backup) Connection – Remove the P9 connector and attach positive and negative 16AWG wires to the connector shown in detail below. Tighten wires to 3in-lbs (0.3Nm). Plug connector back into the P9 location.
D	Route (3) twisted wire along right side of enclosure (Use Hooks in enclosure). Attach wires to 3 position connector and tighten connections to 3 in-lbs. (.3 Nm). Plug Connector into location A8 RS-485 COM B A in detail below

WHAT'S NEEDED

- 1 Drill Template
- 1 Stepper Drill
- 1 Flat Head-Bit
- 1 Torque Driver
- 1 Connector – (2) Position
- 1 Connector – (3) Position

HVDC Wire 8 AWG – 90°C 600v
Communication Wire – 600V to comply with NEC300.3©(1).

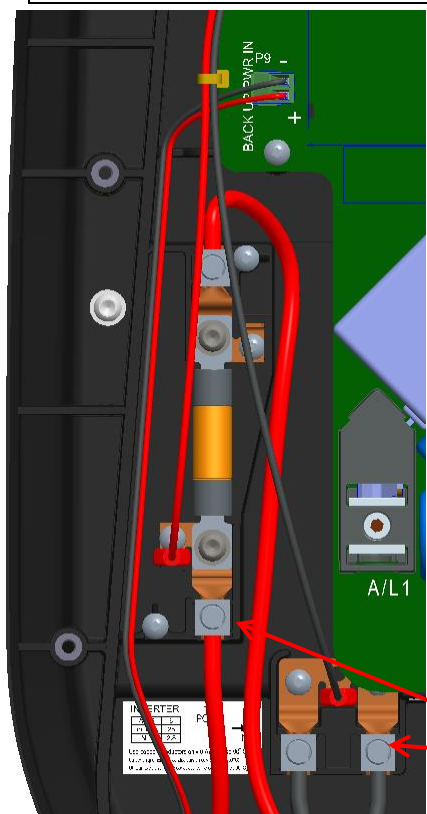

DC Left Wiring

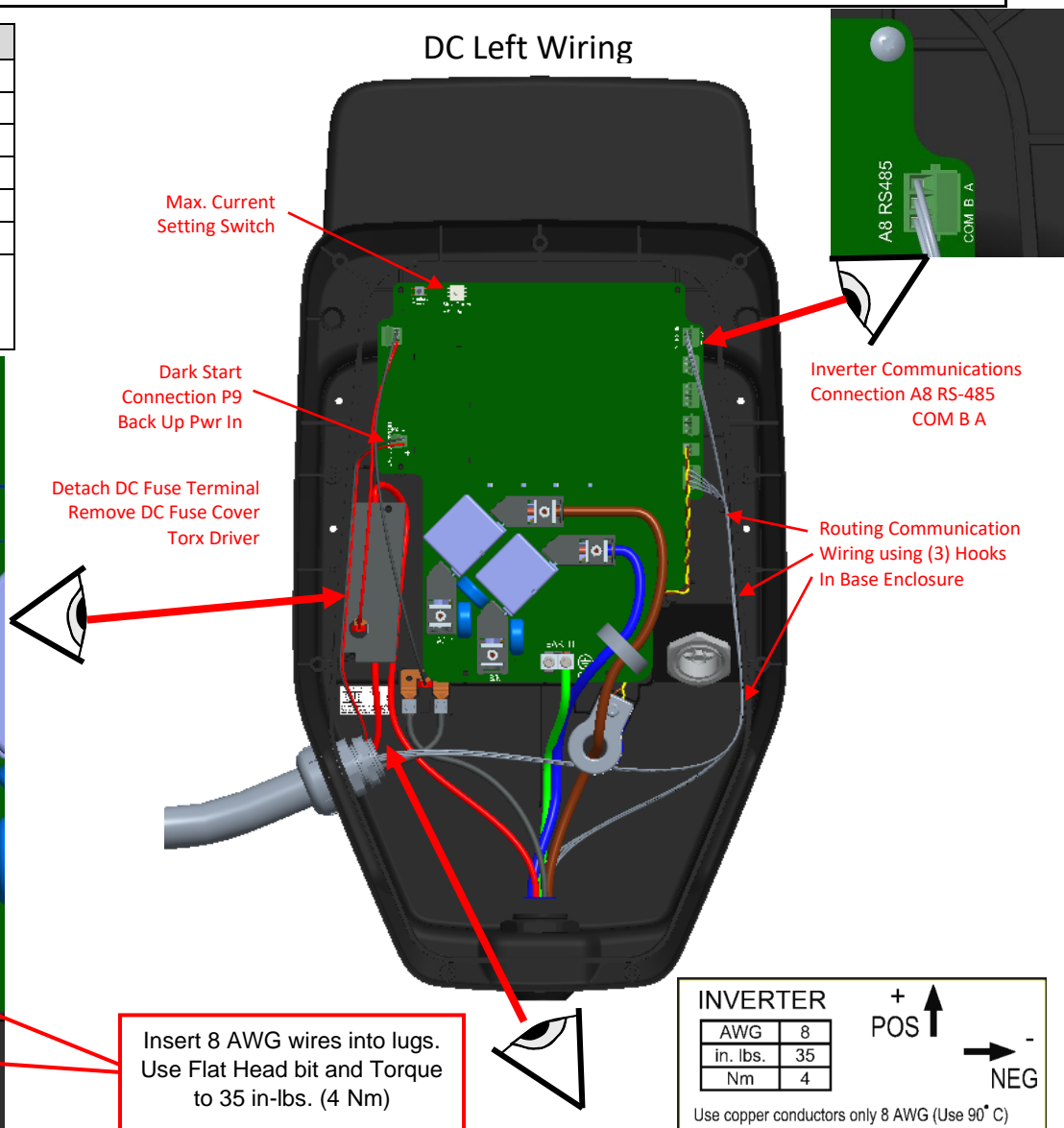

INVERTER		+ POS ↑	- NEG →
AWG	8		
in. lbs.	35		
Nm	4		

Use copper conductors only 8 AWG (Use 90°C)
Utiliser uniquement des conducteurs en cuivre (Utilisez 90°C)
Utilizar exclusivamente conductores de cobre (Utilice 90°C)

HVDC Wiring – Right Entry



DANGER Hazardous voltage. Will cause death or serious injury. Turn off power before working on this equipment. This indicates a situation where the present voltage could cause injury or death. Extreme caution is required when servicing or installing the equipment referenced.

NOTE: Charger will need to be mounted on the bracket to hardwire the device. HVDC wiring first is preferred method.

HVDC Wiring – Route HVDC over EVSE Cable and prior to AC wiring.

A	Use kit-supplied wire drilling template to align and use stepper drill to drill appropriate size hole for 3/4" Conduit connector (Standard hole 1-1/8"). Clean all drill debris from unit. Install Conduit and Connector per manufacturer's installation instruction and route wires into enclosure.
B	HVDC – Detach spade terminal protruding from the DC Fuse Cover. Use Torx Driver to remove DC Fuse Cover. Route 8 AWG – 90°C 600V Copper wires through the conduit and connect Positive wire to Fuse and Negative wire to terminal as shown. Tighten connections to 35 in-lbs. (4 Nm) using a Flat Head Bit. Replace DC Fuse Cover.
C	Dark Start (Battery Backup) Connection – Remove the P9 connector and attach positive and negative 16AWG wires to the connector shown in detail below. Tighten wires to 3in-lbs (0.3Nm). Plug connector back into the P9 location.
D	Route (3) twisted wire along right side of enclosure (Use Hooks in enclosure). Attach wires to 3 position connector and tighten connections to 3 in-lbs. (.3 Nm). Plug Connector into location A8 RS-485 COM B A in detail below

WHAT'S NEEDED

1	Drill Template
1	Stepper Drill
1	Flat Head-Bit
1	Torque Driver
1	Connector – (2) Position
1	Connector – (3) Position
HVDC Wire 8 AWG – 90°C 600v	
Communication Wire – 600V to comply with NEC300.3©(1).	

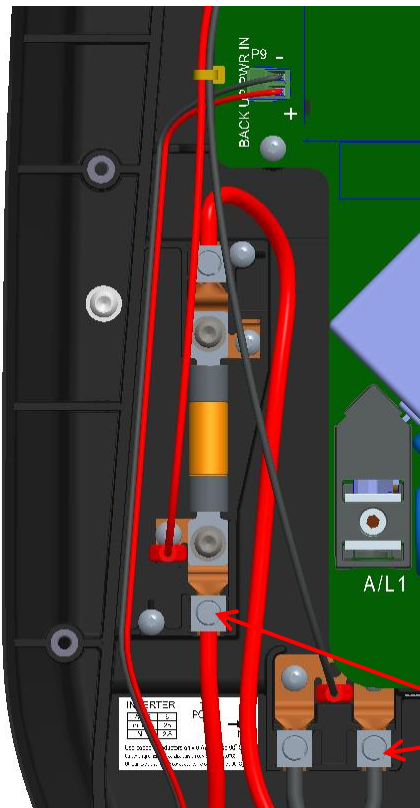

DC Right Wiring

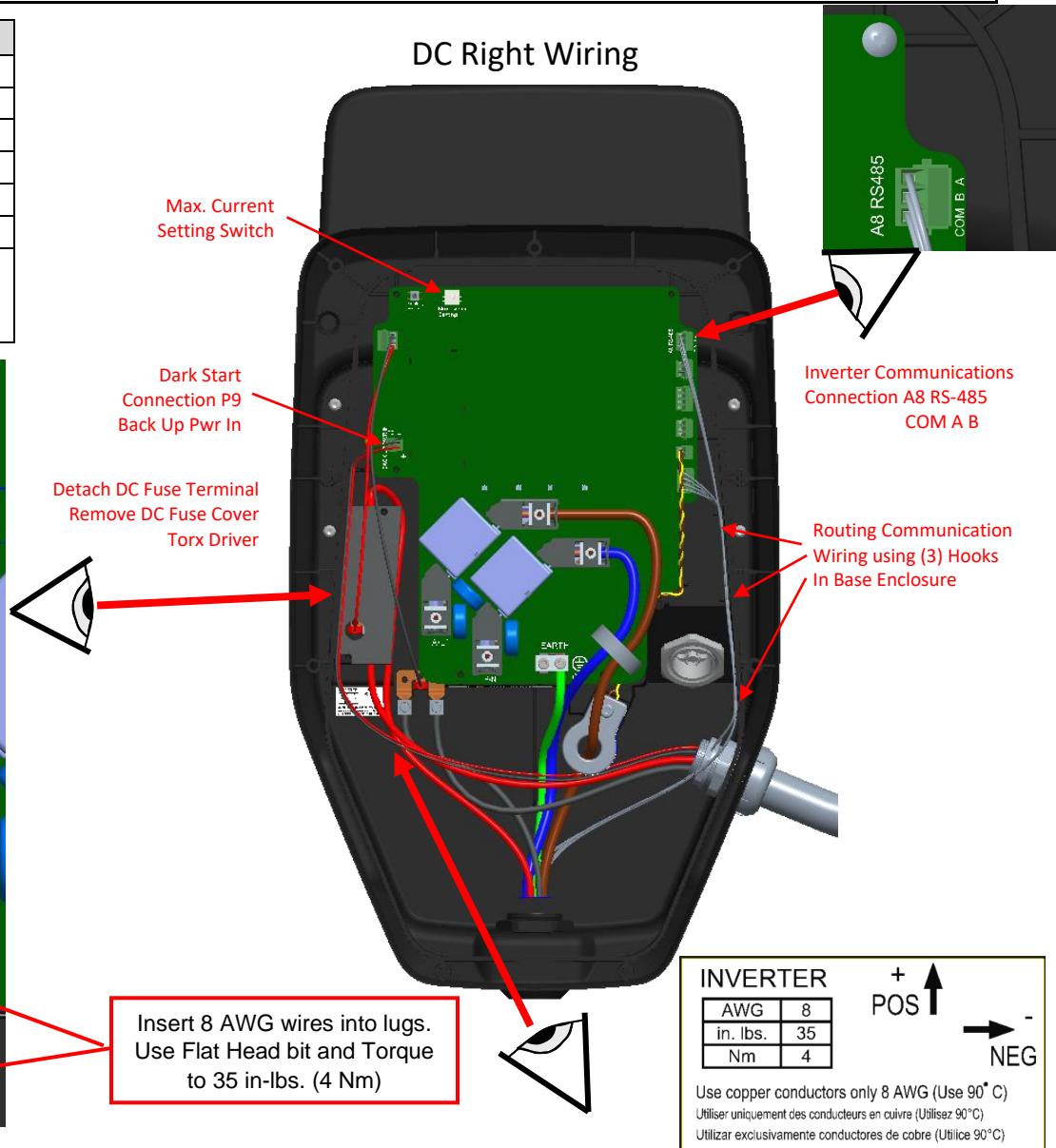

Standard Wiring – Residential Installation – Rear Entry



DANGER Hazardous voltage. Will cause death or serious injury. Turn off power before working on this equipment. This indicates a situation where the present voltage could cause injury or death. Extreme caution is required when servicing or installing the equipment referenced.

NOTE: Charger will need to be mounted on the bracket to hardwire the device.

HVAC Wiring **Route AC wiring over HVDC and EVSE Cable.**

A	The kit-supplied wire drilling template is not necessary; no holes will be drilled for rear entry wiring. Pierce wires through supplied rear plug in ensure watertight seal.
B	HVAC – Route 3 AWG – 90°C 600V Copper wire through the back of the charger and connect per the rear-wiring diagram. Tighten connections to 60 in-lbs. (6.8 Nm) using a 5/32” Hex Head Bit. Black: A(L1) – 120VAC to Ground Red: B(L2[N]) – 120VAC to Ground
C	HVAC – Ground wire – Route 6 AWG or larger 90°C 600V Copper connect the ground per the rear-entry diagram. Tighten connection to 35 in-lbs. (4 Nm) using a 5/32” Hex-Head Bit.
D	Turn on power and using a CAT I – 600v Multimeter (minimum), measure the voltage.

AC Rear Wiring

WHAT'S NEEDED

1 5/32” Hex-Head Bit

1 Torque Driver

3 AWG- 90°C 600v Copper wire should be used

NOTE: Wire **must** have a temperature rating of 90° C or higher

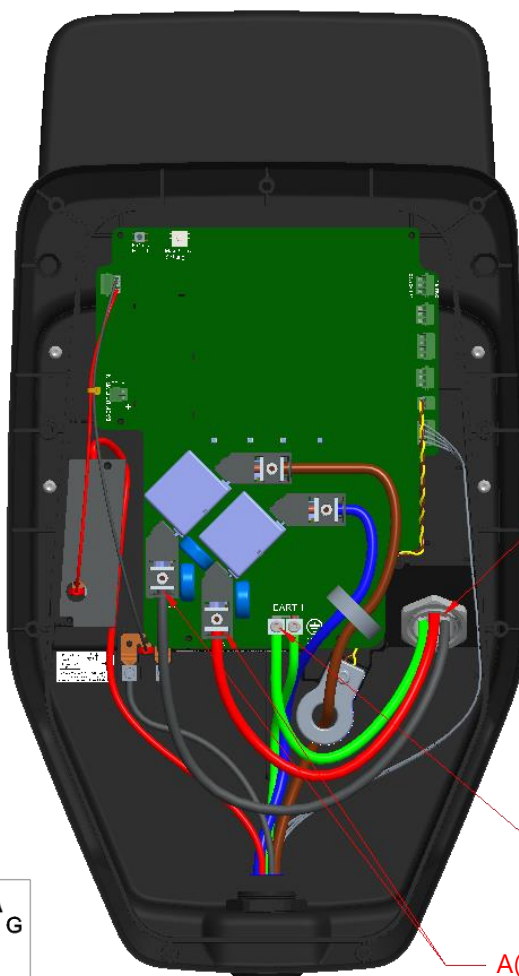
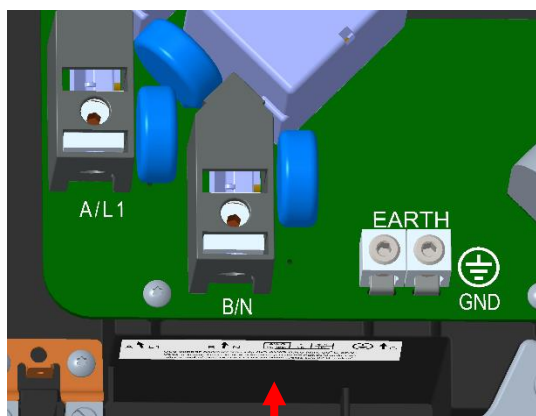

A ↑ L1	B ↑ N	<table border="1"> <tr> <td>AWG</td> <td>3</td> <td>6-4</td> </tr> <tr> <td>in. lbs.</td> <td>60</td> <td>35</td> </tr> <tr> <td>Nm</td> <td>6.8</td> <td>4</td> </tr> </table>	AWG	3	6-4	in. lbs.	60	35	Nm	6.8	4	↑ G
AWG	3	6-4										
in. lbs.	60	35										
Nm	6.8	4										

Use copper conductors only 6-3 AWG (Use Min. 90° C only)
 Utiliser uniquement des conducteurs en cuivre (Utilisez minimum 90°C seulement)
 Utilizar exclusivamente conductores de cobre (Utilice solo 90°C mínimo)

AC Torques

Alternate Wiring – Residential Installation – Left Entry



DANGER Hazardous voltage. Will cause death or serious injury. Turn off power before working on this equipment. This indicates a situation where the present voltage could cause injury or death. Extreme caution is required when servicing or installing the equipment referenced.

NOTE: Charger will need to be mounted on the bracket to hardwire the device.

HVAC Wiring **Route AC wiring over HVDC and EVSE Cable.**

A	Use kit-supplied wire drilling template to align and use stepper drill to drill appropriate size hole for 1" Conduit Hub (Standard hole 1-3/8"). Clean all drill debris from unit. Install Conduit and Connector per manufacturer's installation instruction and route wires into enclosure.
B	HVAC – Route 3 AWG – 90°C 600V Copper wire through the back of the charger and connect per the rear-wiring diagram. Tighten connections to 60 in-lbs. (6.8 Nm) using a 5/32" Hex Head Bit. Black: A(L1) – 120VAC to Ground Red: B(L2[N]) – 120VAC to Ground
C	HVAC – Ground wire – Route 6 AWG or larger 90°C 600V Copper connect the ground per the rear-entry diagram. Tighten connection to 35 in-lbs. (4 Nm) using a 5/32" Hex-Head Bit.
D	Turn on power and using a CAT I – 600v Multimeter (minimum), measure the voltage.

WHAT'S NEEDED	
1	5/32" Hex-Head Bit
1	Torque Driver
3 AWG- 90°C 600v Copper wire should be used	
NOTE: Wire must have a temperature rating of 90° C or higher	

AC Left Wiring

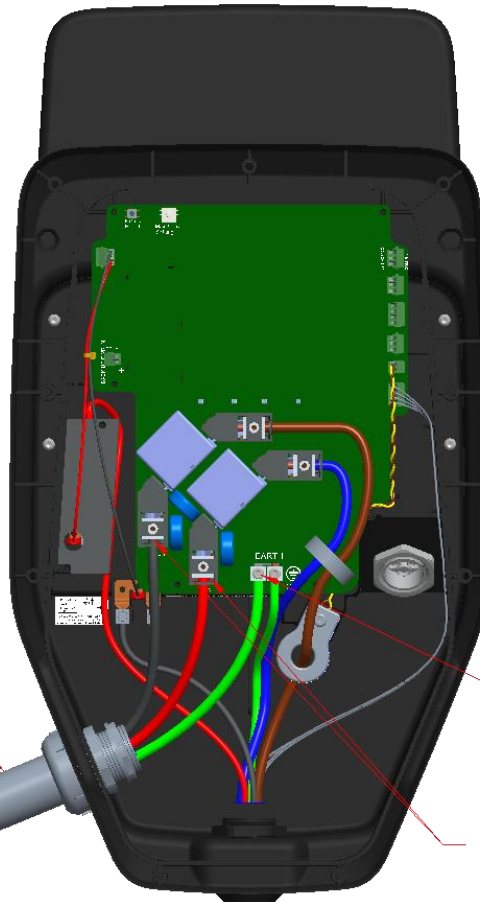
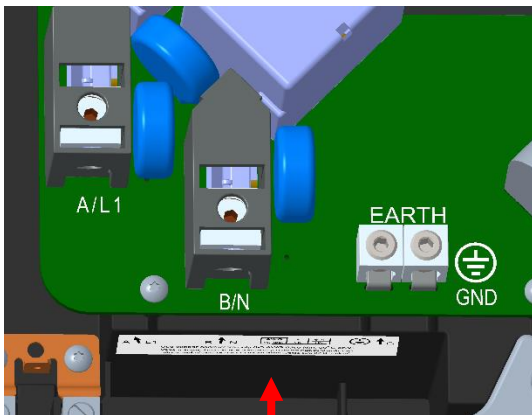

Ground AWG #6
Torque - 35 In/Lbs (4 Nm)

A(L1) & B(L2[N]) AWG #3
Torque - 60 In/Lbs (6.8)

A	L1	B	N		G
AWG	3	6-4			
in. lbs.	60	35			
Nm	6.8	4			

Use copper conductors only 6-3 AWG (Use Min. 90° C only)
Utiliser uniquement des conducteurs en cuivre (Utilisez minimum 90°C seulement)
Utilizar exclusivamente conductores de cobre (Utilice solo 90°C mínimo)

AC Torques

Alternate Wiring – Residential Installation – Right Entry



DANGER Hazardous voltage. Will cause death or serious injury. Turn off power before working on this equipment. This indicates a situation where the present voltage could cause injury or death. Extreme caution is required when servicing or installing the equipment referenced.

NOTE: Charger will need to be mounted on the bracket to hardwire the device.

HVAC Wiring **Route AC wiring over HVDC and EVSE Cable.**

A	Use kit-supplied wire drilling template to align and use stepper drill to drill appropriate size hole for 1" Conduit Hub (Standard hole 1-3/8"). Clean all drill debris from unit. Install Conduit and Connector per manufacturer's installation instruction and route wires into enclosure.
B	HVAC – Route 3 AWG – 90°C 600V Copper wire through the back of the charger and connect per the rear-wiring diagram. Tighten connections to 60 in-lbs. (6.8 Nm) using a 5/32" Hex Head Bit. Black: A(L1) – 120VAC to Ground Red: B(L2[N]) – 120VAC to Ground
C	HVAC – Ground wire – Route 6 AWG or larger 90°C 600V Copper connect the ground per the rear-entry diagram. Tighten connection to 35 in-lbs. (4 Nm) using a 5/32" Hex-Head Bit.
D	Turn on power and using a CAT I – 600v Multimeter (minimum), measure the voltage.

AC Right Wiring

WHAT'S NEEDED	
1	5/32" Hex-Head Bit
1	Torque Driver
3 AWG- 90°C 600v Copper wire should be used	
NOTE: Wire must have a temperature rating of 90° C or higher	

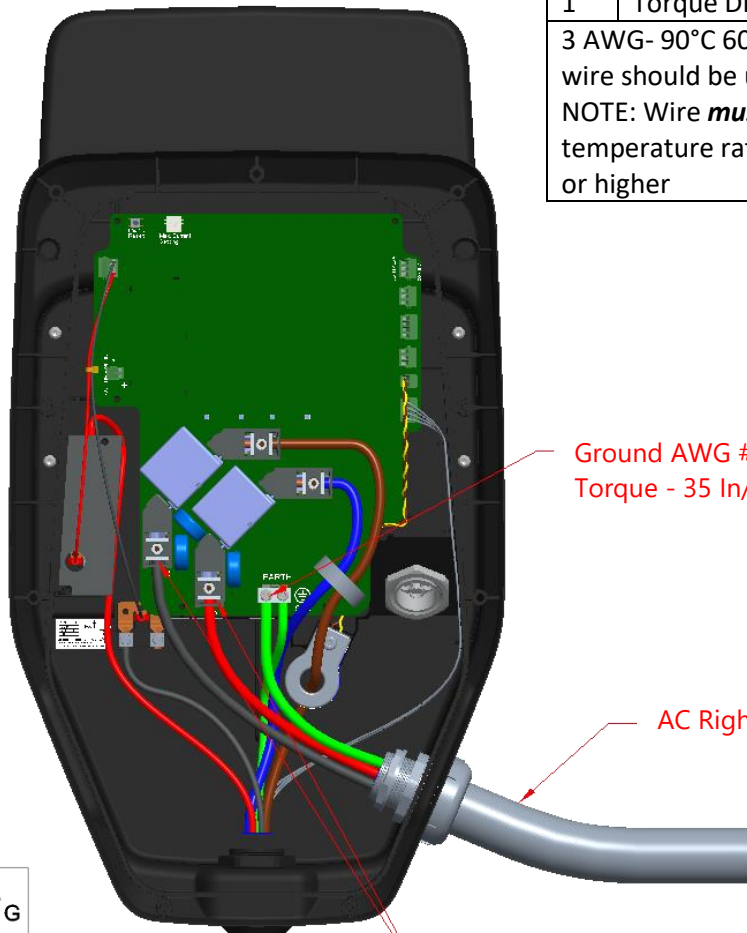
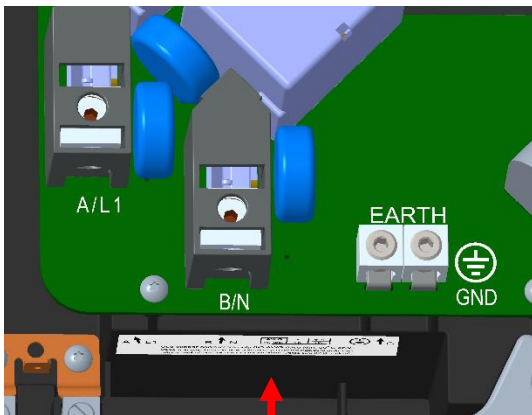

Ground AWG #6
Torque - 35 In/Lbs (4 Nm)

AC Right Entry

A(L1) & B(L2[N]) AWG #3
Torque - 60 In/Lbs (6.8)

A ↑ L1	B ↑ N	<table border="1"> <tr> <td>AWG</td> <td>3</td> <td>6-4</td> </tr> <tr> <td>in. lbs.</td> <td>60</td> <td>35</td> </tr> <tr> <td>Nm</td> <td>6.8</td> <td>4</td> </tr> </table>	AWG	3	6-4	in. lbs.	60	35	Nm	6.8	4	⊕ ↑ G
AWG	3	6-4										
in. lbs.	60	35										
Nm	6.8	4										

Use copper conductors only 6-3 AWG (Use Min. 90° C only)
Utiliser uniquement des conducteurs en cuivre (Utilisez minimum 90°C seulement)
Utilizar exclusivamente conductores de cobre (Utilice solo 90°C mínimo)

AC Torques

Set Maximum Current Switch



DANGER Hazardous voltage. Will cause death or serious injury. Turn off power before working on this equipment. This indicates a situation where the present voltage could cause injury or death. Extreme caution is required when servicing or installing the equipment referenced.

NOTE: The Maximum Current Setting Switch is factory set to (Position 7 – 80A) and verify the required setting based on the branch circuit protection according to NEC Code.

A	Amperage can be reduced by turning the dial to the switch positions as noted in the table below.
B	Based on NEC Code – If current rating switch is used to reduce the current rating, please indicate the new current setting on the exterior of the unit.

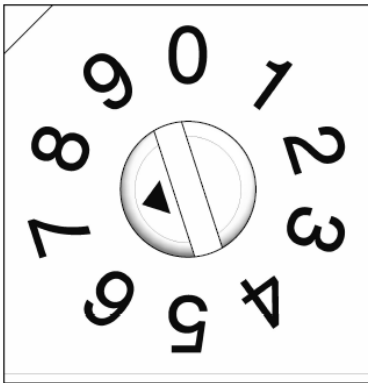

Maximum Current Setting Switch

SWITCH POSITION	AMPS
0	12
1	16
2	24
3	32
4	40
5	48
6	64
7	80
8	n/a
9	n/a

Close the Charger

	<p>DANGER Hazardous voltage. Will cause death or serious injury. Turn off power before working on this equipment. This indicates a situation where the present voltage could cause injury or death. Extreme caution is required when servicing or installing the equipment referenced.</p>
<p>A</p>	<p>Verify Gasket has not dislodged from Cover groove. Replace the structural cover on the unit and attach using (9) M4 x 0.7 x 16 mm screws retained when removed earlier. Torque to 10 in-lbs. (1.1 Nm) using Torx Head (T20) Bit. Torque in order shown (left) for proper sealing of Cover.</p>
<p>B</p>	<p>Carefully Align the decorative cover with the Structural Cover and firmly press the decorative cover in place ensuring that all snaps are fully seated</p>
<p>C</p>	<p>Download “Ford Charge Station Pro App” and “Ford Pass”</p>

QTY	WHAT'S NEEDED
9	Torx-head Screws – M4 x 0.7 x 16 mm Retained from earlier step.
1	Decorative Cover
TOOLS NEEDED	
1	Torx-Head (T20) Bit
1	Torque Driver

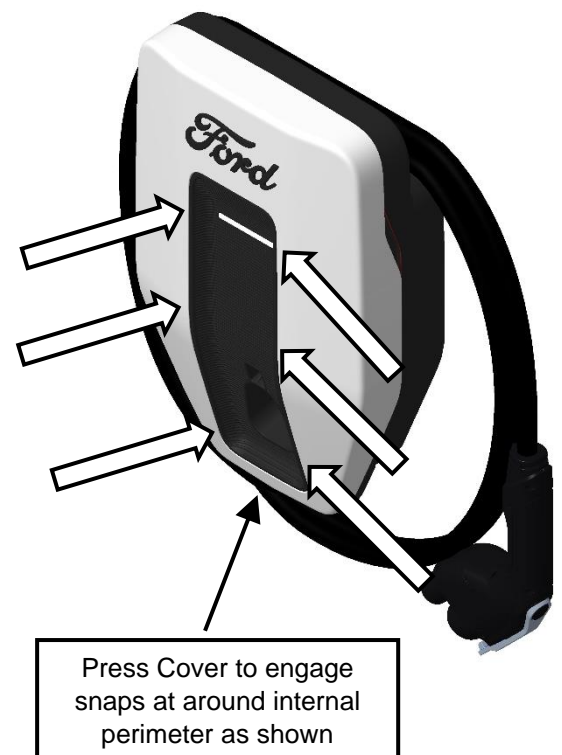
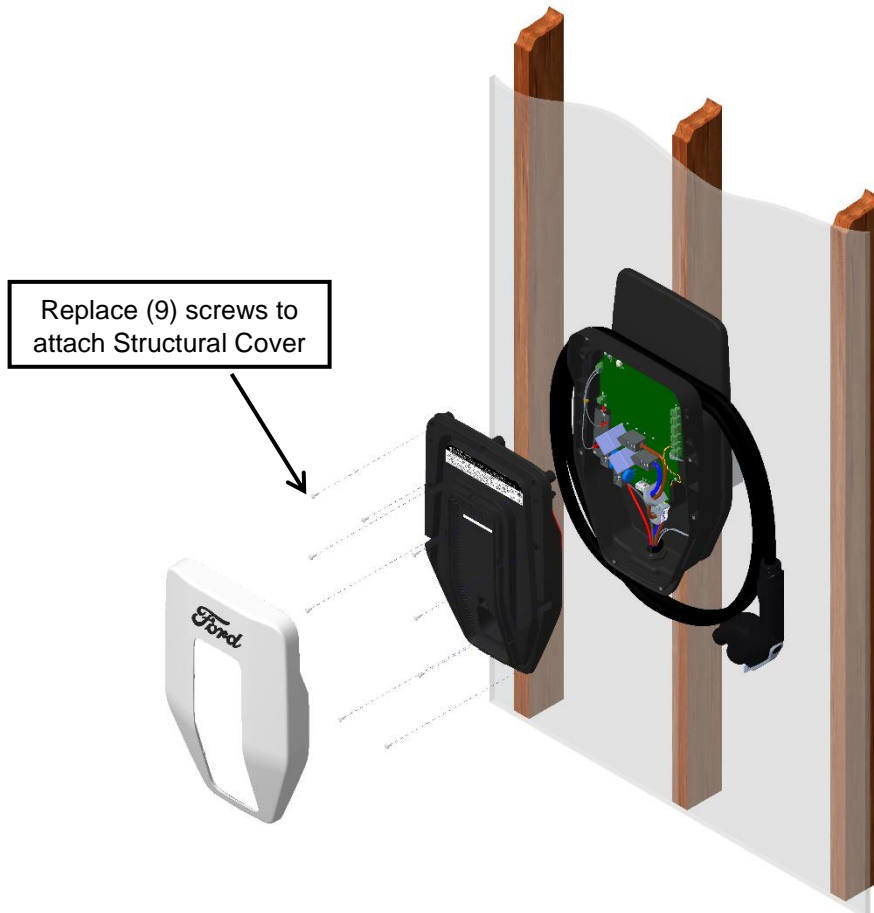

Operating Instructions

Safety Instructions During the Charging Process



DANGER Risk of electric shock and fire. Touching live parts may cause electric shock or even death. Defective connectors or cables may cause fire.

- Do not kink or squeeze the charging cable. Do not draw the charging cable over sharp edges or hot surfaces
- Do not use the charging station if damage or tampering is visible. If damage is visible, Inform the operator. Until damage is repaired, keep away from the charging station and do not attempt to charge an EV.
- Grip the power plug/connector to disconnect from the charging unit. Do not remove the connector by pulling on the cable.
- Never touch the power plug/connector with wet hands.
- Do not connect or disconnect any cables during a thunderstorm.
- The Charge Station is equipped with an auto-reset feature. – If this Charge Station is connected to a vehicle at the time that power is restored following an outage, charging may resume automatically. – If this Charge Station is connected to a vehicle and a ground fault trip occurs, charging may resume automatically after a delay period.

Risk of Overheating and Fire

Unauthorized accessories should not be used with this device due to risk of fire and/or overheating.

- DO NOT use a charging cable that is not approved for the vehicle.
- DO NOT use an extension to connect the charging station to the vehicle
- DO NOT use an adapter or adapter cable.













Basic Charging Procedure

- Using the charger connector, gently insert the connector into the EV. Be sure not to force the connection or bend any pins in the connector.
- Observe blue LED on the front of the device
 - Dim blue- Device not connected/Standby
 - Bright blue- Device ready to deliver energy
 - Pulsing blue- Device delivering energy to the vehicle

Intelligent Backup Power

- For operating instructions regarding this feature, please refer to your vehicle manual

LED Status

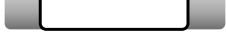
	Status	Explanation
	Off	The station is not powered by grid or battery backup
	Dim blue	The station is grid powered
	Bright blue	The station is grid powered, plugged in and ready to charge
	Pulsing blue	The station is plugged and and charging
	Dim green	The station is powered by battery backup and not plugged in
	Bright green	The station is powered by battery backup, plugged in and ready to discharge
	Pulse green	The station is powered by battery backup, plugged in and discharging
	Pulse Green/Pulse Blue	The station is powered and locked. Station will not charge or discharge
	Solid red	The station has experienced a non-recoverable fault
	Solid amber	The station has a fault and trouble shooting is required
	Pulse Red	The station has experienced a ground fault
	Solid Amber/Pulse Blue	The station is charging at a reduced rate
	Pulsing White	Setup mode Wifi/Bluetooth
	Solid White	Station Reset

Maintenance

While there is no maintenance for the internal works of the unit, the exterior does require some basic, common sense maintenance. The following maintenance can be performed by the owner/user. All other service must be conducted by qualified personnel. If there is any damage to the charger, contact Ford. General exterior maintenance is recommended to be performed every six months depending on the environment. In harsh environments, maintenance should be performed more often.

General exterior maintenance

Regular cleaning is recommended to avoid accumulation of debris/dust/dirt on or around the unit. Wipe surfaces with a soft cloth dampened with water, or for harder to removed marks, use an alcohol based cleaner. Do not spray with high-pressure cleaning devices or use abrasive chemicals. Check for cuts, cracks, damage, and debris. If debris is present, remove it. If you find damage, contact Ford. Check for damage and corrosion. If present, contact Ford. Check the HMI for damage/signs of faded color that is clearly visible. Ensure there is no debris or damage inside or around the cable, cable holder and connector/plug. If present, remove debris and/or notify the Ford of any damage. Check the connector/plug pins for any signs of corrosion and contact Ford, if there is any damage to the pins. Check for Snow/Ice buildup around the unit and clear the area around the unit. This should be checked daily in areas with high snowfall.

Appendix A – Conduit Drilling Template (Compatible with suggested gland/conduit configurations)

RIGHT SIDE

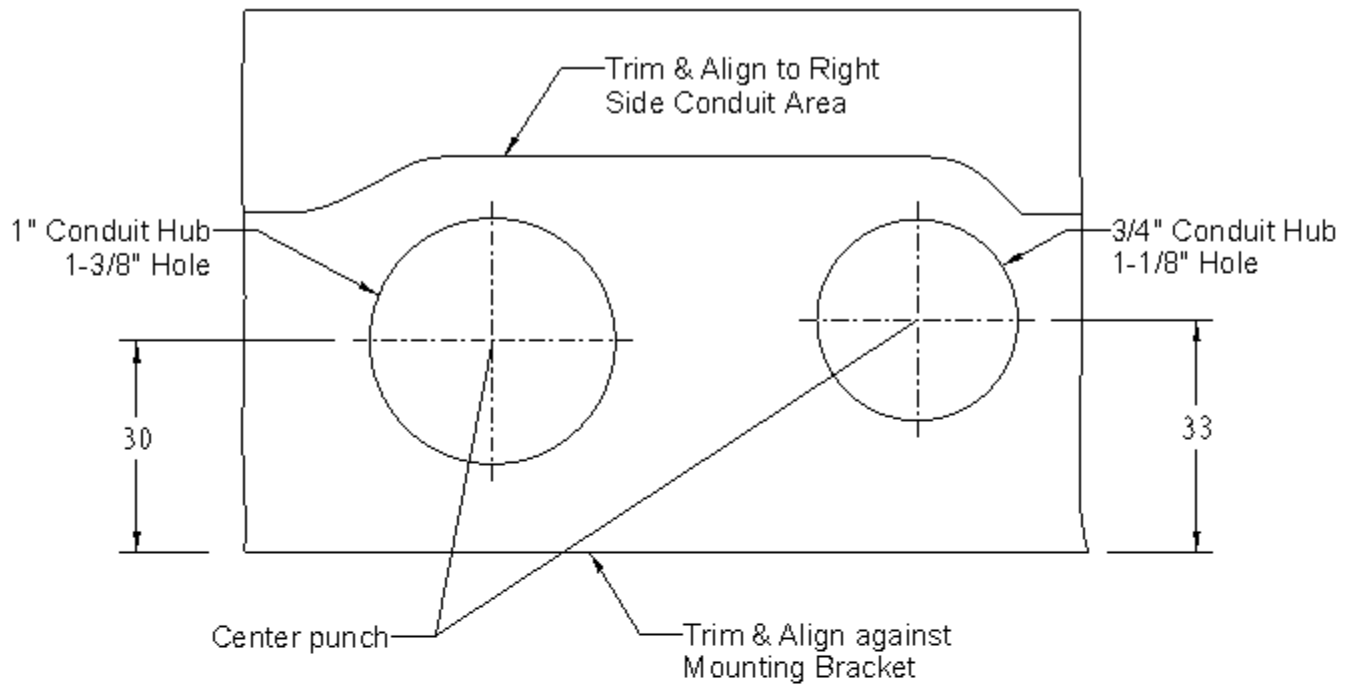

LEFT SIDE

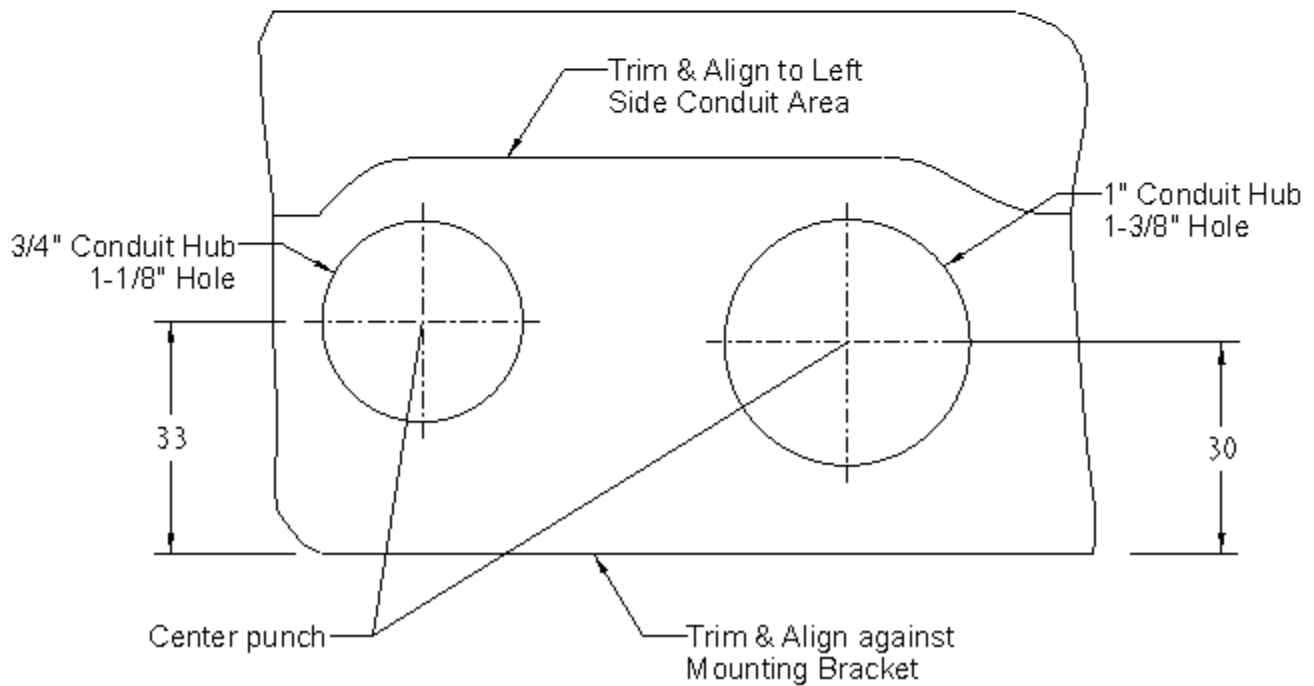

Ford Charge Station Pro – Technical data

Features and Functions

Charging Mode	Level 2
Vehicle Connection	J1772 CCS Combo 1 plug with 25 ft cable, 80 A / integrated cable management
AC Power Output	Up to 19.2 kW (240VAC@80A) - Requires a 100A breaker
Mounting Options	Wall

Communication

Interfaces	Wi-Fi, Bluetooth
Configuration	via Charge Station Pro Configuration App
Software Upgrade	over the air (OTA)

Electrical Design

Power Supply Voltage	208V/240V AC, 60Hz
Rated Current Settings [A]	12, 16, 32, 40, 48, 64, 80
Wire Cross Section	3 AWG, Min. 90°C Rated
Network Type	Phase shift / Split phase
Ground Fault Protection	20 mA
Over Current Protection	+10% above configured threshold

General Design

Environmental Rating	UL Type 4
Dimensions (HxWxD)	23.8 in. x 12.7 in. x 7 in.
Boxed Weight	24 lbs
Ambient Conditions	-40°C to +45°C Operational, -40°C to +85°C Storage

Certificates

UL Listed	according to UL 9741, UL 991, UL 1998, UL 2231, file no. E522055
-----------	--



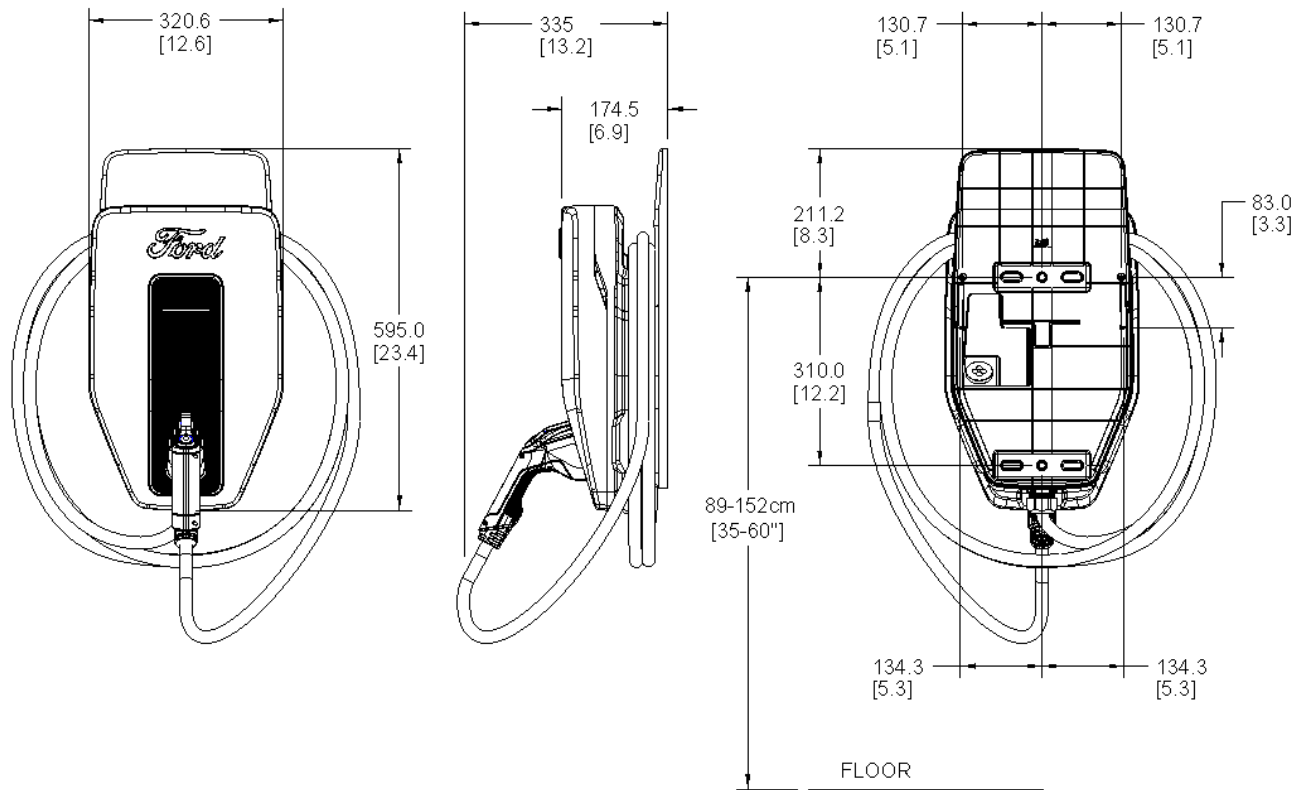



Legal Manufacturer

Siemens Industry, Inc.
 3617 Parkway Ln
 Peachtree Corners, GA 30092
 United States of America
 Telephone: +1 (800) 333-7421
 recharge.us@siemens.com
 © 01.2022, Siemens Industry, Inc.

This document contains a general description of available technical options only, and its effectiveness will be subject to specific variables including field conditions and project parameters. Siemens does not make representations, warranties, or assurances as to the accuracy or completeness of the content contained herein. Siemens reserves the right to modify the technology and product specifications in its sole discretion without advance notice.

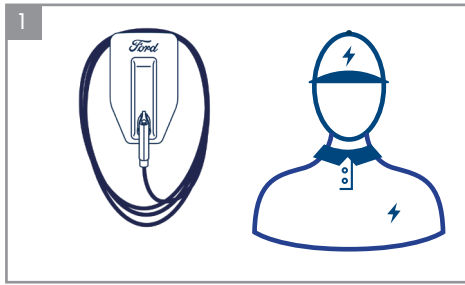
QUICK START GUIDE TO CONFIGURE YOUR CHARGE STATION PRO



 Ensure the Charge Station Pro has been installed by a qualified electrician.

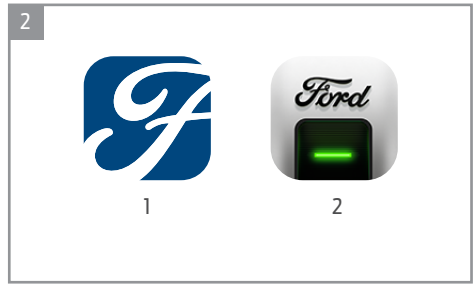

 Download required apps:
1) FordPass™
2) Ford Charge Station Pro Setup™

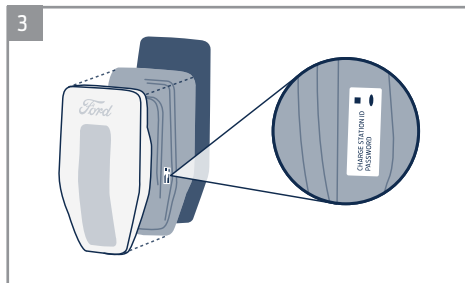

 Locate the sticker with your Station ID and password on the front of the User Manual or on a sticker under the face plate.

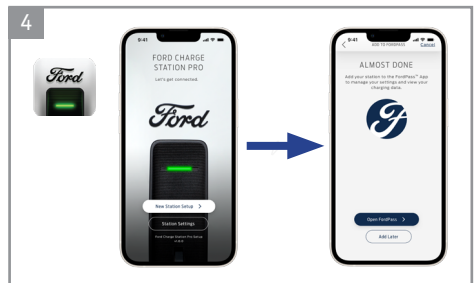

 Launch the Charge Station Pro Setup app, select "New Station Setup" and follow these steps until completing by clicking on "Open FordPass".

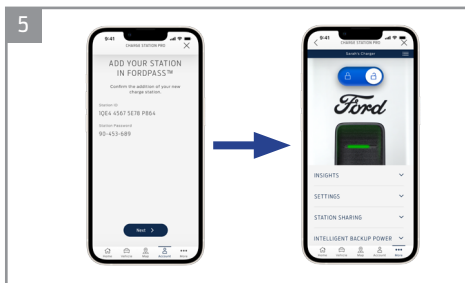

 After FordPass automatically opens follow the instructions to complete setup.

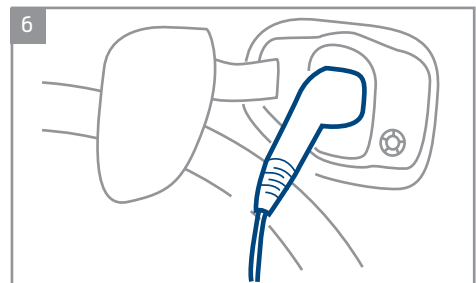

 Plug in and enjoy exploring your station's capabilities.

- Intelligent Backup Power allows you to provide power to your home from your vehicle battery during power outages. In addition to this Ford Charge Station Pro a Home Integration System is required to operate Intelligent Backup Power. To learn more about Intelligent Backup Power visit [Ford.com/connected](https://www.ford.com/connected).
- Ford Charge Station Pro requires Wi-Fi connection to enable smart features in FordPass.