

VICINITY MAP

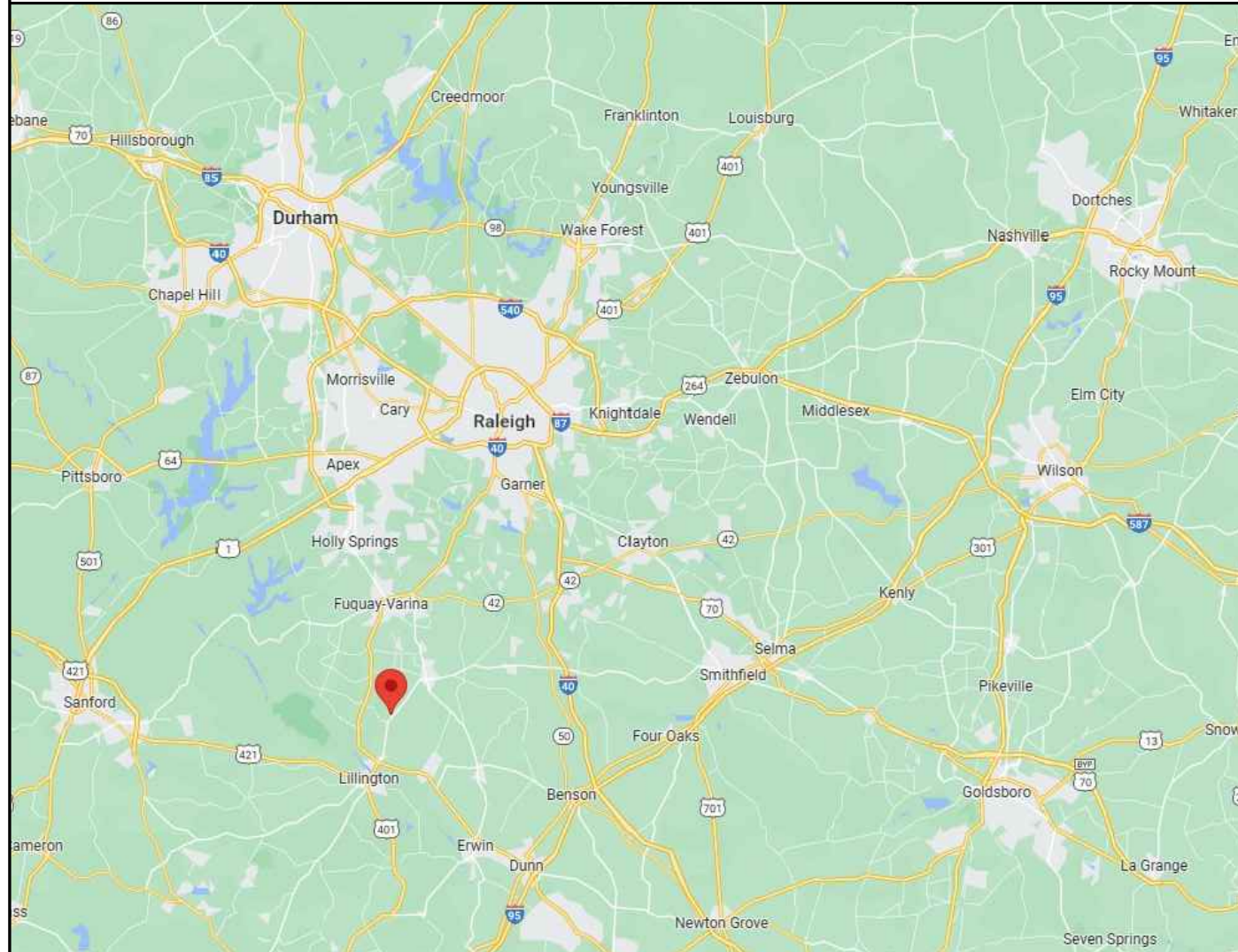

PROPERTY MAP



ENGINEER:



MODEL ENERGY

300 FAYETTEVILLE ST.
#1430
RALEIGH, NC 27602
919-274-9905
MODELENERGY.COM
P-1194

JOB TITLE:

NEW SOLAR PV SYSTEM

4.740 kW DC INPUT
3.900 kW AC EXPORT

Cynetta Mitchell
171 Barnsley Rd,
Angier, NC 27501

© 2023 MODEL ENERGY, PLLC EXPRESSLY RESERVES ITS COMMON LAW COPYRIGHT AND OTHER PROPERTY RIGHTS IN THESE PLANS. THESE PLANS ARE NOT TO BE REPRODUCED, CHANGED OR COPIED IN ANY FORM OR MANNER WHATSOEVER, NOR ARE THEY TO BE ASSIGNED TO ANY THIRD PARTY WITHOUT FIRST OBTAINING THE EXPRESSED WRITTEN PERMISSION AND CONSENT OF MODEL ENERGY, PLLC.

CLIENT:



ISSUED FOR: DATE:
CONSTRUCTION 7/27/2023

PROJECT INFORMATION

PV1.1

SCOPE OF WORK

(12) MISSION SOLAR MSE395SX9R
(12) ENPHASE IQ8M-72-2-US
ROOF MOUNT: SNAPRACK L-FOOT
MOUNTING RAILS: SNAPRACK UR-40

SITE CONDITION

ASCE 7-10 WIND SPEED - 115 MPH
EXPOSURE CATEGORY - B
RISK CATEGORY - II
SNOW LOAD - 10 LBS/SQFT

SHEET INDEX

PV1.1 PROJECT INFORMATION
PV2.1 SITE INFORMATION
PV3.1 STRUCTURAL INFORMATION
PV4.1 - 4.2 ELECTRICAL INFORMATION
PV5.1 - 5.5 LABELS, DETAILS & SPECS

INTERCONNECTIONS TYPE

BACKFED BREAKER

CODE REFERENCES

2017 NATIONAL ELECTRIC CODE
2018 NORTH CAROLINA FIRE CODE
2018 NORTH CAROLINA BUILDING CODE
2018 NORTH CAROLINA RESIDENTIAL CODE

UTILITY COMPANY

DUKE ENERGY

LEGEND

- DISCONNECT SWITCH
- FUSE
- CIRCUIT BREAKER
- EQUIP. GROUND



ENGINEER:



MODEL ENERGY

300 FAYETTEVILLE ST.
#1430

RALEIGH, NC 27602
919-274-9905

MODELENERGY.COM

P-1194

JOB TITLE:

NEW SOLAR PV SYSTEM

4.740 kW DC INPUT

3.900 kW AC EXPORT

Cynetta Mitchell

171 Barnsley Rd,

Angier, NC 27501

© 2023 MODEL ENERGY, PLLC EXPRESSLY RESERVES ITS COMMON LAW COPYRIGHT AND OTHER PROPERTY RIGHTS IN THESE PLANS. THESE PLANS ARE NOT TO BE REPRODUCED, CHANGED OR COPIED IN ANY FORM OR MANNER WHATSOEVER, NOR ARE THEY TO BE ASSIGNED TO ANY THIRD PARTY WITHOUT FIRST OBTAINING THE EXPRESSED WRITTEN PERMISSION AND CONSENT OF MODEL ENERGY, PLLC.

CLIENT:



ISSUED FOR:

DATE:

CONSTRUCTION

7/27/2023

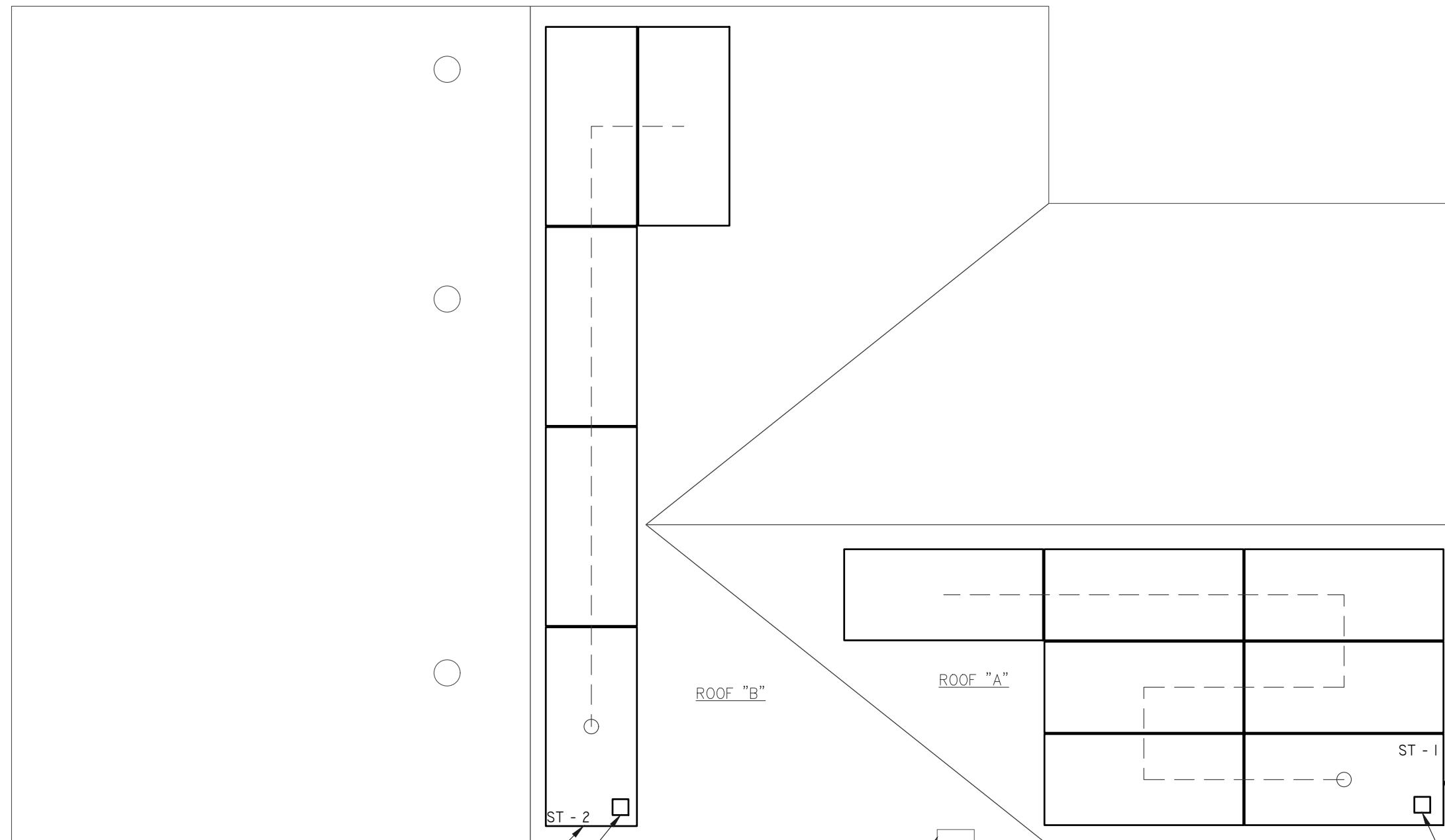
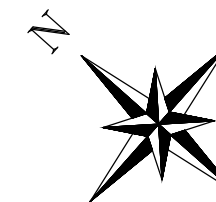

PV MODULE (TYP.)
JUNCTION BOX

MD PANEL
UTILITY METER
AC DISCONNECT
IQ COMBINER PANEL

PV MODULE (TYP.)
JUNCTION BOX

NOTE: PROVIDE ADDITIONAL JUNCTION BOXED AS REQUIRED TO COMBINE MODULES ON DIFFERENT ARRAYS INTO A SINGLE STRING

1 SITE PLAN
SCALE: 1/4" = 1' -0"

SITE INFORMATION
PV2.1

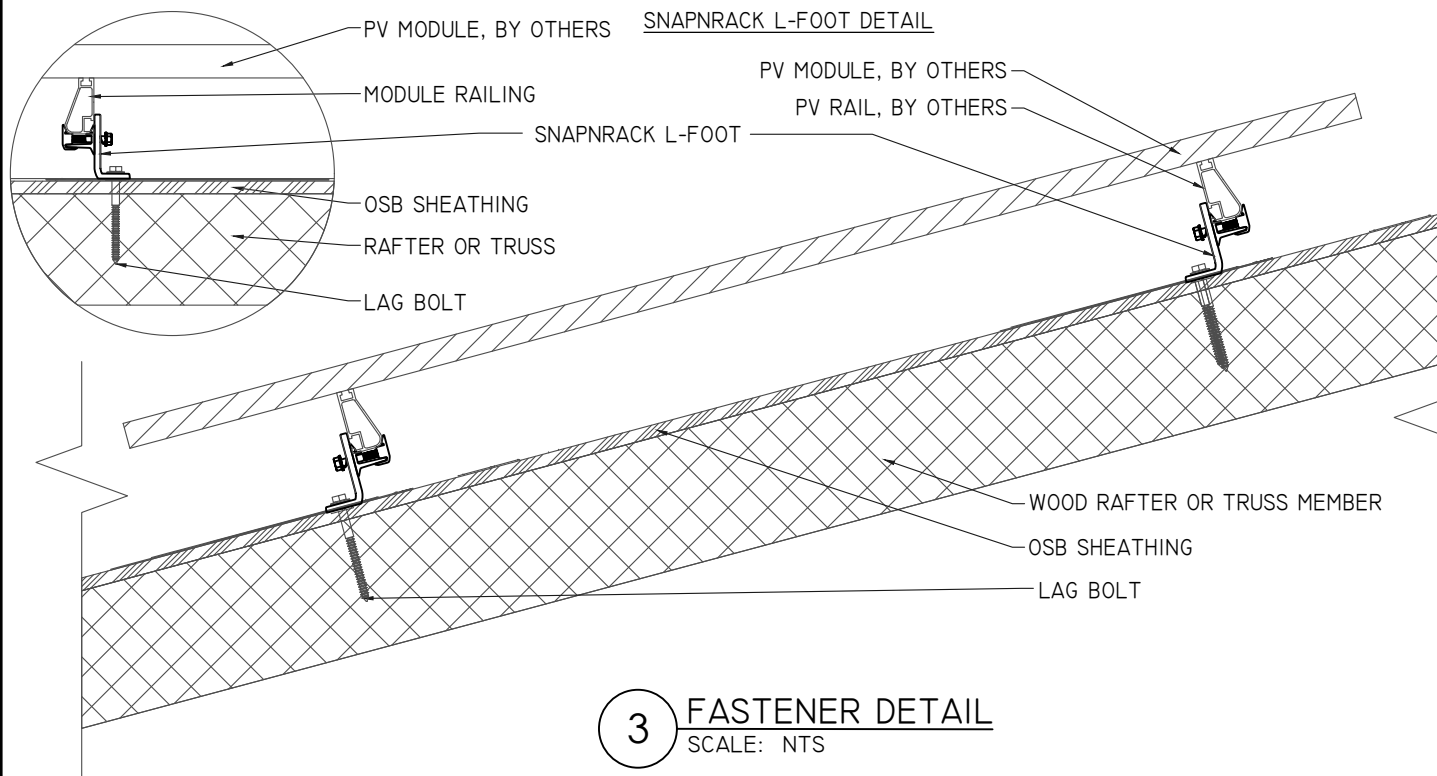

3 FASTENER DETAIL
SCALE: NTS

ARRAY "B" SUMMARY

# MODULES	5
# ROOF MOUNTS	22
RAIL LENGTH	71 FT.
ARRAY AREA	108 SQFT.
ARRAY WEIGHT	272 LBS.
AZIMUTH @ SN	160°
TILT ANGLE	34°

ARRAY "A" SUMMARY

# MODULES	7
# ROOF MOUNTS	27
RAIL LENGTH	178 FT.
ARRAY AREA	151 SQFT.
ARRAY WEIGHT	1082 LBS.
AZIMUTH @ SN	150°
TILT ANGLE	34°

MOUNTING RAILS

MAKE	SNAPRACK
MODEL	UR-40
MATERIAL	ALUMINUM
WEIGHT	0.42 LBS/SQFT
SPACING	34"

PV MODULES

MAKE	MISSION SOLAR
MODEL	MSE395SX9R
WIDTH	41.5"
LENGTH	75.1"
THICKNESS	1.6"
WEIGHT	49 LBS

STATEMENT OF STRUCTURAL COMPLIANCE

THE EXISTING ROOF STRUCTURE HAS BEEN DESIGNED TO SUPPORT THE ADDITIONAL LOADS OF THE PURPOSED PV SYSTEM. IN ADDITION, THE RACKING AND FASTENING SYSTEM SHALL BE CAPABLE OF SECURING THE SYSTEM TO THE STRUCTURE UNDER DESIGN CONDITIONS WHEN INSTALLED PROPERLY AND IN ACCORDANCE WITH THE RACKING AND FASTENING ARRANGEMENT DETAILED WITHIN THESE DRAWINGS.

SIGNED: 

NAME: ANDREW W. KING, PE

TITLE: PROFESSIONAL ENGINEER

ROOF SUMMARY

STRUCTURE:	
TYPE	TRUSS
MATERIAL	SOUTHERN PINE #2
SIZE	2" X 4"
SPACING	24"
EFF. SPAN	
ROOF "A"	10' - 1"
ROOF "B"	16' - 3"
PITCH	
ROOF "A"	8/12
ROOF "B"	8/12
DENSITY	30 LBS./CU.FT.
DECKING:	
TYPE	OSB
MATERIAL	WOOD COMPOSITE
THICKNESS	7/16
WEIGHT	1.6 LBS./SQFT.
ROOFING:	
TYPE	ARCH SHINGLE
MATERIAL	ASPHALT
WEIGHT	2.3 LBS./SQFT.

ROOF MOUNT & FASTENER

ROOF MOUNT:	
MAKE	SNAPRACK
MODEL	L-FOOT
MATERIAL	ALUMINUM
FASTENER	
MAKE	GENERIC
MODEL	LAG BOLT
MATERIAL	304 SS
SIZE	5/16" X 4"
GENERAL	
WEIGHT	1 LBS
FASTENERS PER MOUNT	1 PER MOUNT
MAX. PULL-OUT FORCE	800 LBS.
SAFETY FACTOR	2
DESIGN PULL-OUT FORCE	400 BS.

- LAG BOLT EMBEDDED WITH 2.5" OF THREAD IN WOOD RAFTER OR TRUSSES MEMBER

ROOF LOADING

GROUND SNOW LOAD:	15 LBS./SQFT.
LIVE LOAD:	20 LBS./SQFT.
DEAD LOAD:	
ROOFING	3.9 LBS./SQFT.
PV ARRAY	3.0 LBS./SQFT.
TOTAL	6.9 LBS./SQFT.
WIND LOAD:	
UPLIFT ZONE 1	-24.6 LBS/SQFT
UPLIFT ZONE 2	-29.0 LBS/SQFT
UPLIFT ZONE 3	-29.0 LBS/SQFT
DOWNWARD	23.0 LBS/SQFT
FASTENER LOAD:	
UPLIFT ZONE 1	-255 LBS
UPLIFT ZONE 2	-201 LBS
UPLIFT ZONE 3	-100 LBS
DOWNWARD	239 LBS

ROOF ZONES:

ALL ZONES	MAX. RAIL OVERHANG =	16"
□ ZONE 1	MAX. FASTENER SPAN ZONE 1 =	72"
▨ ZONE 2	MAX. FASTENER SPAN ZONE 2 =	48"
▩ ZONE 3	MAX. FASTENER SPAN ZONE 3 =	24"

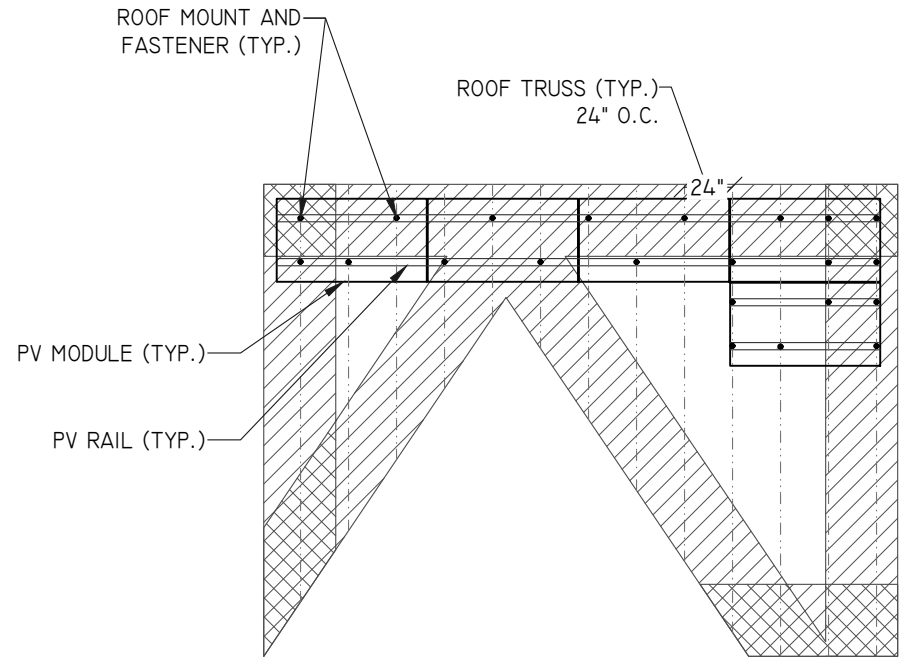

1 ROOF "B" PLANAR VIEW
SCALE: 1/8" = 1' -0"

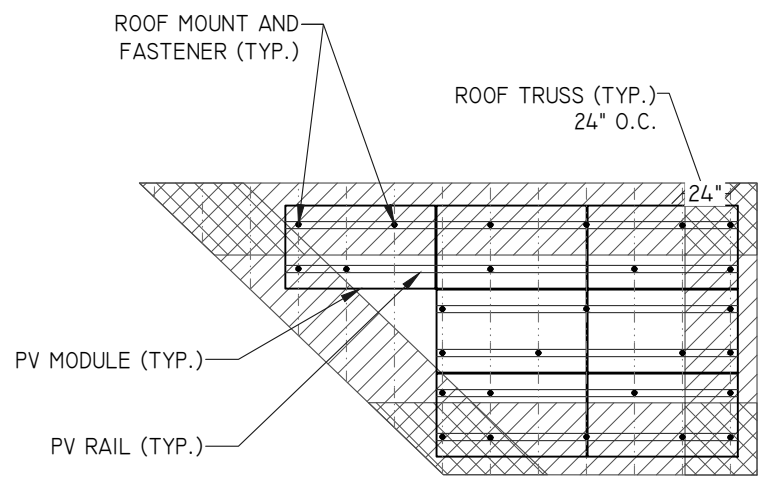

1 ROOF "A" PLANAR VIEW
SCALE: 1/8" = 1' -0"

ENGINEER:



MODEL ENERGY

300 FAYETTEVILLE ST.
#1430
RALEIGH, NC 27602
919-274-9905
MODELENERGY.COM
P-1194

JOB TITLE:

NEW SOLAR PV SYSTEM

4.740 kW DC INPUT
3.900 kW AC EXPORT

Cynetta Mitchell
171 Barnsley Rd,
Angier, NC 27501

© 2023 MODEL ENERGY, PLLC EXPRESSLY RESERVES ITS COMMON LAW COPYRIGHT AND OTHER PROPERTY RIGHTS IN THESE PLANS. THESE PLANS ARE NOT TO BE REPRODUCED, CHANGED OR COPIED IN ANY FORM OR MANNER WHATSOEVER, NOR ARE THEY TO BE ASSIGNED TO ANY THIRD PARTY WITHOUT FIRST OBTAINING THE EXPRESSED WRITTEN PERMISSION AND CONSENT OF MODEL ENERGY, PLLC.

CLIENT:



ISSUED FOR:	DATE:
CONSTRUCTION	7/27/2023

STRUCTURAL INFORMATION

PV3.1

PV MODULES	
MAKE	MISSION SOLAR
MODEL	MSE395SX9R
TECHNOLOGY	MONO-CRYST.
NOM. POWER (Pnom)	395 WATTS
NOM. VOLT. (Vmp)	40.09 VOLTS
O.C. VOLT. (Voc)	36.99 VOLTS
MAX. SYS. VOLT.	1000 V (UL)
TEMP. COEF. (Vtc)	-0.259 %/°C
NOM. CURR. (Imp)	10.68 AMPS
S.C. CURR. (Isc)	11.24 AMPS
MAX. SERIES FUSE	20 AMPS

JUNCTION BOX	
MAKE	SOLADECK
MODEL	0783-3R
PRO. RATING	NEMA 3R
VOLT. RATING	600 VOLTS
AMP RATING	120 AMPS
UL LISTING	UL 50

DC/AC INVERTER	
MAKE	ENPHASE ENERGY
MODEL	IQ8M-72-2-US
TECHNOLOGY	MICRO INVERTER
DC INPUT:	
MAX. POWER	460 WATTS
VOLT. RANGE	25-58 VOLTS
MAX. CURRENT	15 AMPS
AC OUTPUT:	
NOM. POWER	325 WATTS
NOM. VOLT.	240 VOLTS
MAX. CURR.	1.35 AMPS
GFP (Y/N)	YES
GFCI (Y/N)	YES
AFCI (Y/N)	YES
DC DISC. (Y/N)	NO
RAPID SHUTDOWN	YES
FUSE RATING	15 AMPS
PROTECT. RATING	NEMA 6R

CONDUCTOR SCHEDULE													
TAG	CURRENT CARRYING CONDUCTORS				GROUNDING CONDUCTORS				CONDUIT/RACEWAY				NOTES
	QTY.	SIZE	MATERIAL	INSULATION	QTY.	SIZE	MATERIAL	INSULATION	QTY.	SIZE	MATERIAL	LOCATION	
C1	2	10 AWG	COPPER	MANU. CAB.	1	6 AWG	COPPER	BARE	-	-	-	FREE AIR	1
C2	2	12 AWG	COPPER	MANU. CAB.	1	6 AWG	COPPER	BARE	-	-	-	FREE AIR	1
C3	4	10 AWG	COPPER	THWN-2	1	10 AWG	COPPER	THWN-2	1	1/2"	FMC/EMT/MC	EXT/INT	2,4
C4	3	10 AWG	COPPER	THWN	1	10 AWG	COPPER	THWN	1	1/2"	NOTE 5	INT/EXT	2,4,5
XC	-	-	-	-	-	-	-	-	-	-	-	-	3

NOTES:

1. MANUFACTURER PROVIDED, UL LISTED WIRING HARNESS FOR USE ON EXPOSED ROOFS
2. CONDUIT SIZE SHOWN IS CODE MINIMUM. LARGER SIZES ARE ALLOWED.
3. EXISTING CONDUCTORS, FIELD VERIFY
4. EQUIPMENT TERMINAL RATING SHALL BE A MINIMUM OF 75°C AT BOTH END OF CONDUCTOR
5. PVC, EMT, ROMEX, LFNMC & FMC ARE ACCEPTABLE WHEN USED IN ACCORDANCE WITH ARTICLES 330, 334, 348, 350, 352, 356, & 358 OF THE 2017 NEC

IQ COMBINER PANEL (NEW)	
MAKE	N/A
MODEL	N/A
ENCL. RATING	NEMA 3R
VOLT. RATING	240 VOLTS
BUS RATING	200 AMPS
UL LIST. (Y/N)	YES
MAIN BREAKER (Y/N)	NO
BREAKER RATING	N/A

NOTES:

- BACK-FEED INVERTER OUTPUT VIA (2) 15A BREAKERS AT THE OPPOSITE END OF THE BUS BAR FROM MAIN BREAKER.
- PROVIDE "FED BY MULTIPLE POWER SOURCES" LABEL.

AC DISCONNECT	
MAKE	GENERIC
MODEL	N/A
ENCL. RATING	NEMA 3R
VOLT. RATING	240 VOLTS
AMP RATING	30 AMPS
UL LIST. (Y/N)	YES
FUSED (Y/N)	NO
FUSE RATING	N/A

NOTES:

- LOAD-BREAK RATED
- VISIBLE OPEN
- LOCKABLE IN OPEN POSITION
- INSTALL ADJACENT TO METER
- DISCONNECT TO BE READILY ACCESSIBLE TO UTILITY COMPANY PERSONNEL AT ALL TIMES

MD PANEL (EXISTING)	
MAKE	N/A
MODEL	N/A
ENCL. RATING	NEMA 3R
VOLT. RATING	240 VOLTS
BUS RATING	200 AMPS
UL LIST. (Y/N)	YES
MAIN BREAKER (Y/N)	YES
BREAKER RATING	200 AMPS

NOTES:

- BACK-FEED SOLAR OUTPUT VIA 25A BREAKER AT THE OPPOSITE END OF THE BUS BAR FROM MAIN BREAKER.
- MAIN BREAKER SERVES AS SERVICE DISCONNECT SWITCH.

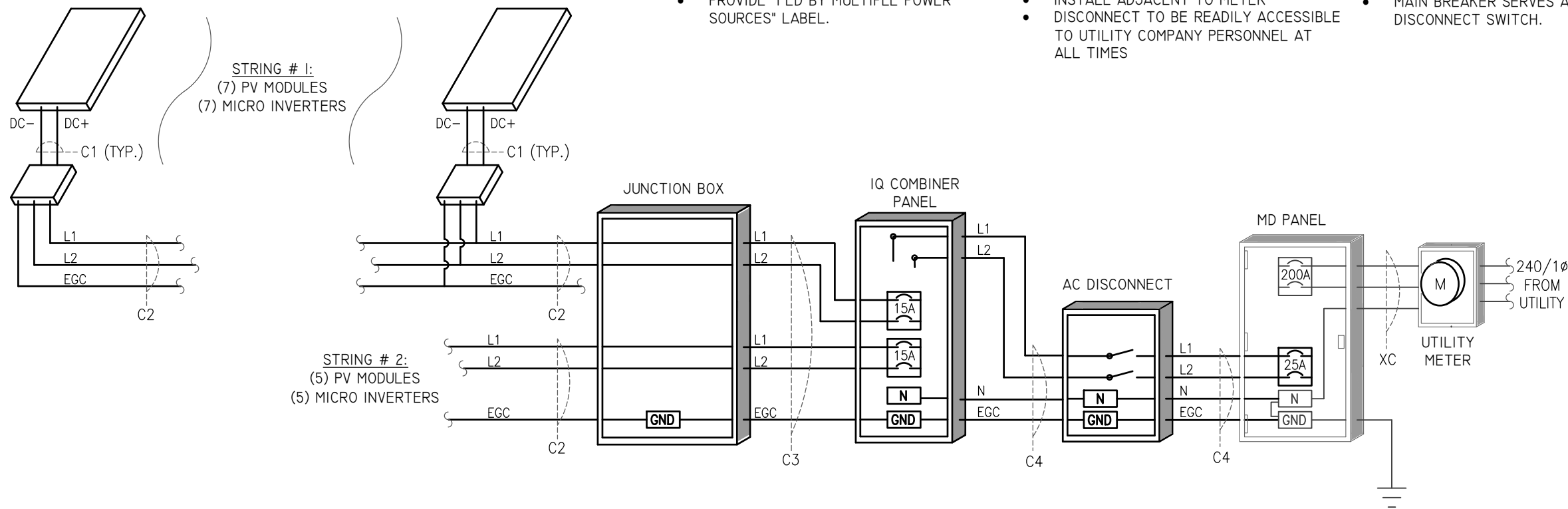

1 PV SYSTEM ELECTRICAL WIRING SCHEMATIC
SCALE: NTS

ENGINEER:



MODEL ENERGY
300 FAYETTEVILLE ST.
#1430
RALEIGH, NC 27602
919-274-9905
MODELENERGY.COM
P-1194

JOB TITLE:

NEW SOLAR PV SYSTEM

4.740 kW DC INPUT
3.900 kW AC EXPORT

Cynetta Mitchell
171 Barnsley Rd,
Angier, NC 27501

© 2023 MODEL ENERGY, PLLC EXPRESSLY RESERVES ITS COMMON LAW COPYRIGHT AND OTHER PROPERTY RIGHTS IN THESE PLANS. THESE PLANS ARE NOT TO BE REPRODUCED, CHANGED OR COPIED IN ANY FORM OR MANNER WHATSOEVER, NOR ARE THEY TO BE ASSIGNED TO ANY THIRD PARTY WITHOUT FIRST OBTAINING THE EXPRESSED WRITTEN PERMISSION AND CONSENT OF MODEL ENERGY, PLLC.

CLIENT:



ISSUED FOR: CONSTRUCTION
DATE: 7/27/2023

ELECTRICAL INFORMATION

PV4.1

EQUIPMENT LABELS

SOLAR PV SYSTEM EQUIPPED WITH RAPID SHUTDOWN

TURN RAPID SHUTDOWN SWITCH TO THE "OFF" POSITION TO SHUT DOWN PV SYSTEM AND REDUCE SHOCK HAZARD IN THE ARRAY

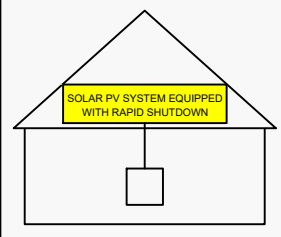

NEC 690.56 (C)(1)(a)
PLACE WITHIN 3FT OF SERVICE DISCONNECTING MEANS TO WHICH THE PV SYSTEMS ARE CONNECTED AND SHALL INDICATE THE LOCATIONS OF RAPID SHUTDOWN SWITCHES

PV SYSTEM DISCONNECT

NEC 690.13 (B)
PLACE ON PV SYSTEM DISCONNECTING MEANS.

⚠ WARNING

DUAL POWER SUPPLY

SOURCES: UTILITY GRID AND PV SOLAR ELECTRIC SYSTEM

NEC 705.12 (B)(3)
PLACE ON ALL EQUIPMENT THAT IS SUPPLIED BY BOTH POWER SOURCES

⚠ WARNING

ELECTRIC SHOCK HAZARD

TERMINALS ON THE LINE AND LOAD SIDES MAY BE ENERGIZED IN THE OPEN POSITION

NEC 690.13 (B)
PLACE ON PV SYSTEM DISCONNECTING MEANS.

⚠ WARNING

POWER SOURCE OUTPUT CONNECTION DO NOT RELOCATE THIS OVERCURRENT DEVICE

NEC 705.12 (B)(2)(3)(b)
PLACE ADJACENT TO BACK-FED BREAKER

WARNING: PHOTOVOLTAIC POWER SOURCE

NEC 690.31 (G)(3)&(4)
PLACE ON ALL JUNCTION BOXES, EXPOSED RACEWAYS, AND OTHER WIRING METHODS EVERY 10' AND ON EVERY SECTION SEPARATED BY ENCLOSURES, WALLS, PARTITIONS, CEILINGS, OR FLOORS.

⚠ WARNING

FED BY MULTIPLE POWER SOURCES

TOTAL RATING OF ALL OVERCURRENT DEVICES EXCLUDING UTILITY OVERCURRENT DEVICE SHALL NOT EXCEED AMPACITY OF BUSBAR

NEC 705.12 (B)(2)(3)(c)
PLACE ADJACENT TO BACK-FED BREAKER

PHOTOVOLTAIC POWER SOURCE

OPERATING AC VOLT. 240 VAC
MAXIMUM OPERATING AC OUTPUT CURRENT 16.2 AMPS

NEC 690.54
PLACE ON INTERCONNECTION DISCONNECTING MEANS

RAPID SHUTDOWN SWITCH FOR SOLAR PV SYSTEM

NEC 690.56 (C)(3)
PLACE ON RAPID SHUTDOWN SWITCH OR EQUIPMENT WITH INTEGRATED RAPID SHUTDOWN *REFLECTIVE*

EQUIPMENT LABEL NOTES

1. LABELS SHOWN ARE 1/2 THEIR ACTUAL REQUIRED SIZE.
2. LABEL MATERIAL SHALL BE SUITABLE FOR THE EQUIPMENT ENVIRONMENT.
3. CONDUIT SHALL BE MARKED WITH REQUIRED LABEL EVERY 10 FEET.

CONSTRUCTION NOTES

1. ALL WORK AND EQUIPMENT SHALL BE INSTALLED IN ACCORDANCE WITH THE LATEST NATIONAL, STATE, AND LOCAL CODES AND ORDINANCES
2. FOLLOW MANUFACTURER'S INSTALLATION INSTRUCTIONS, BEST PRACTICES, AND SPECIFICATIONS
3. WIRES SHALL BE RATED AND LABELED "SUNLIGHT RESISTANT" WHERE EXPOSED TO AMBIENT CONDITIONS
4. THE PHOTOVOLTAIC SYSTEM SHALL NOT EXCEED 600 VOLTS OR 800 AMPS
5. EACH ELECTRICAL APPLIANCE SHALL BE PROVIDED WITH A NAMEPLATE GIVING THE IDENTIFYING NAME AND THE RATING IN VOLTS AND AMPERES, OR VOLTS AND WATTS. IF THE APPLIANCE IS TO BE USED ON A SPECIFIC FREQUENCY OR FREQUENCIES, IT SHALL BE SO MARKED. WHERE MOTOR OVERLOAD PROTECTION EXTERNAL TO THE APPLIANCES IS REQUIRED, THE APPLIANCE SHALL BE SO MARKED
6. WHERE APPLICABLE, GROUNDING ELECTRODE CONDUCTOR TO BE CONTINUOUS. GROUNDING CRIMPS TO BE IRREVERSIBLE
7. IN ONE- AND TWO-FAMILY DWELLINGS, LIVE PARTS IN PHOTOVOLTAIC SOURCE CIRCUITS AND PHOTOVOLTAIC OUTPUT CIRCUITS OVER 150 VOLTS TO GROUND, SHALL ONLY BE ACCESSIBLE TO QUALIFIED PERSONS WHILE ENERGIZED.
8. PHOTOVOLTAIC SYSTEMS SHALL BE PERMANENTLY MARKED AT VARIOUS EQUIPMENT LOCATIONS TO IDENTIFY THAT A PHOTOVOLTAIC SYSTEM IS INSTALLED AND THAT VARIOUS DANGERS ARE PRESENT.
9. EACH PHOTOVOLTAIC SYSTEM DISCONNECTING MEANS SHALL BE PERMANENTLY MARKED TO IDENTIFY IT AS A PHOTOVOLTAIC SYSTEM DISCONNECT
10. WHERE ALL TERMINALS OF A DISCONNECTING MEANS MAY BE ENERGIZED IN THE OPEN POSITION, A WARNING SIGN SHALL BE MOUNTED ON OR ADJACENT TO THE DISCONNECT
11. A PERMANENT LABEL FOR THE DIRECT-CURRENT PHOTOVOLTAIC POWER SOURCE SHALL BE PROVIDED BY THE INSTALLED AT THE DC DISCONNECT MEANS
12. A PERMANENT PLAQUE OR DIRECTORY, DENOTING ALL ELECTRIC POWER SOURCES SERVING THE PREMISES, SHALL BE INSTALLED AT EACH SERVICE EQUIPMENT LOCATION AND AT LOCATIONS OF ALL POWER PRODUCTION SOURCES.
13. A PERMANENT PLAQUE OR DIRECTORY SHALL BE PROVIDED DENOTING THE LOCATIONS OF THE SERVICE DISCONNECT MEANS AND THE PHOTOVOLTAIC SYSTEM DISCONNECT MEANS IF THEY ARE NOT LOCATED AT THE SAME LOCATION.
14. ALL MODULE GROUND CONNECTIONS SHALL BE MADE IN ACCORDANCE WITH NEC SECTION 690.4 (C)

ENGINEER:



MODEL ENERGY

300 FAYETTEVILLE ST.
#1430
RALEIGH, NC 27602
919-274-9905
MODELENERGY.COM
P-1194

JOB TITLE:

NEW SOLAR PV SYSTEM

4.740 kW DC INPUT
3.900 kW AC EXPORT

Cynetta Mitchell
171 Barnsley Rd,
Angier, NC 27501

© 2023 MODEL ENERGY, PLLC EXPRESSLY RESERVES ITS COMMON LAW COPYRIGHT AND OTHER PROPERTY RIGHTS IN THESE PLANS. THESE PLANS ARE NOT TO BE REPRODUCED, CHANGED OR COPIED IN ANY FORM OR MANNER WHATSOEVER, NOR ARE THEY TO BE ASSIGNED TO ANY THIRD PARTY WITHOUT FIRST OBTAINING THE EXPRESSED WRITTEN PERMISSION AND CONSENT OF MODEL ENERGY, PLLC.

CLIENT:



ISSUED FOR:	DATE:
CONSTRUCTION	7/27/2023

ELECTRICAL
INFORMATION

PV4.2

MSE PERC 66

MISSION SOLAR ENERGY



395W

Class leading power output -0 to +3%

Positive Power Tolerance

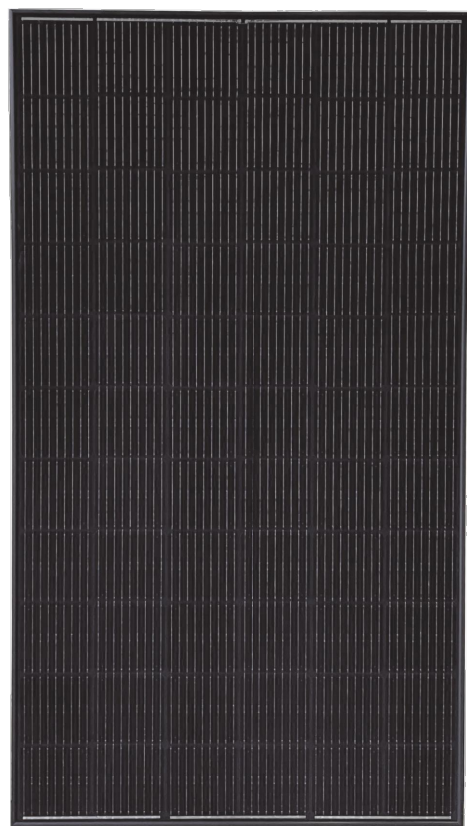

True American Quality True American Brand

Mission Solar Energy is headquartered in San Antonio, Texas where we manufacture our modules. We produce American, high-quality solar modules ensuring the highest-in-class power output and best-in-class reliability. Our product line is tailored for residential, commercial and utility applications. Every Mission Solar Energy solar module is certified and surpasses industry standard regulations, proving excellent performance over the long term.

Demand the best. Demand Mission Solar Energy.



Certified Reliability

- Tested to UL 61730 & IEC Standards
- PID resistant
- Resistance to salt mist corrosion



Advanced Technology

- 9 Busbar
- Passivated Emitter Rear Contact
- Ideal for all applications



Extreme Weather Resilience

- Up to 5,400 Pa front load & 3,600 Pa back load
- Tested load to UL 61730
- 40 mm frame



BAA Compliant for Government Projects

- Buy American Act
- American Recovery & Reinvestment Act

CERTIFICATIONS



UL 61730 / IEC 61215 / IEC 61730 / IEC 61701

If you have questions or concerns about certification of our products in your area, please contact Mission Solar Energy.



Class Leading 390-400W

MSE PERC 66

BASIC DIMENSIONS

[UNITS: MM/IN]

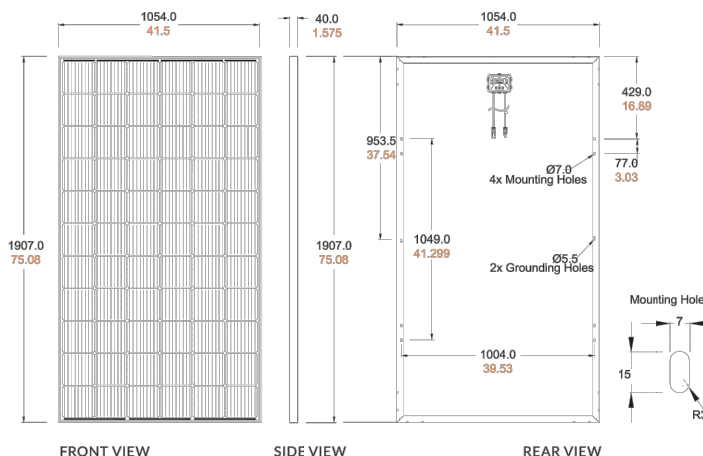

CURRENT-VOLTAGE CURVE

MSE385SX9R: 385WP, 66 CELL SOLAR MODULE

Current-voltage characteristics with dependence on irradiance and module temperature

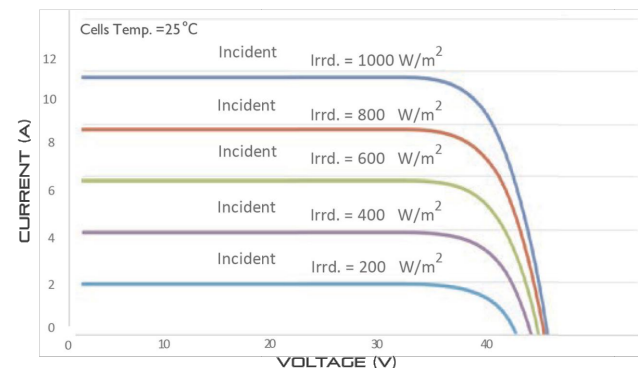

CERTIFICATIONS AND TESTS

IEC	61215, 61730, 61701
UL	61730



CEC



Mission Solar Energy

8303 S. New Braunfels Ave., San Antonio, Texas 78235
www.missionsolar.com | info@missionsolar.com

Mission Solar Energy reserves the right to make specification changes without notice.
C-SA2-MKTG-0027 REV 4 03/18/2022

ELECTRICAL SPECIFICATION

PRODUCT TYPE	MSExxxSX9R (xxx = P _{max})			
Power Output	P _{max} W _p	390	395	400
Module Efficiency	%	19.4	19.7	19.9
Tolerance	%	0/+3	0/+3	0/+3
Short Circuit Current	I _{sc} A	11.19	11.24	11.31
Open Circuit Voltage	V _{oc} V	45.04	45.18	45.33
Rated Current	I _{mp} A	10.63	10.68	10.79
Rated Voltage	V _{mp} V	36.68	36.99	37.07
Fuse Rating	A	20	20	20
System Voltage	V	1,000	1,000	1,000

TEMPERATURE COEFFICIENTS

Normal Operating Cell Temperature (NOCT)	43.75°C (±3.7%)
Temperature Coefficient of P _{max}	-0.367%/°C
Temperature Coefficient of V _{oc}	-0.259%/°C
Temperature Coefficient of I _{sc}	0.033%/°C

OPERATING CONDITIONS

Maximum System Voltage	1,000Vdc
Operating Temperature Range	-40°F to 185°F (-40°C to +85°C)
Maximum Series Fuse Rating	20A
Fire Safety Classification	Type 1*
Front & Back Load (UL Standard)	Up to 5,400 Pa front and 3,600 Pa back load, Tested to UL 61730
Hail Safety Impact Velocity	25mm at 23 m/s

*Mission Solar Energy uses quality sourced materials that result in a Type 1 fire rating. Please note, the 'Fire Class' Rating is designated for the fully-installed PV system, which includes, but is not limited to, the module, the type of mounting used, pitch and roof composition.

MECHANICAL DATA

Solar Cells	P-type mono-crystalline silicon
Cell Orientation	66 cells (6x11)
Module Dimension	1,907mm x 1,054mm x 40mm
Weight	48.5 lbs. (22 kg)
Front Glass	3.2mm tempered, low-iron, anti-reflective
Frame	40mm Anodized
Encapsulant	Ethylene vinyl acetate (EVA)
Junction Box	Protection class IP67 with 3 bypass-diodes
Cable	1.2m, Wire 4mm2 (12AWG)
Connector	Staubli PV-KBT4/6II-UR and PV-KST4/6II-UR, MC4, Renhe 05-8

SHIPPING INFORMATION

Container Feet	Ship To	Pallet	Panels	390W Bin
53'	Most States	30	780	304.20 kW
Double Stack	CA	26	676	263.64 kW

PALLET [26 PANELS]

Weight	Height	Width	Length
1,300 lbs. (572 kg)	47.56 in (120.80 cm)	46 in (116.84 cm)	77 in (195.58 cm)

ENGINEER:



MODEL ENERGY

300 FAYETTEVILLE ST.
#1430

RALEIGH, NC 27602
919-274-9905

MODELENERGY.COM

P-1194

JOB TITLE:

NEW SOLAR PV SYSTEM

4.740 kW DC INPUT

3.900 kW AC EXPORT

Cynetta Mitchell

171 Barnsley Rd,

Angier, NC 27501

© 2023 MODEL ENERGY, PLLC EXPRESSLY RESERVES ITS COMMON LAW COPYRIGHT AND OTHER PROPERTY RIGHTS IN THESE PLANS. THESE PLANS ARE NOT TO BE REPRODUCED, CHANGED OR COPIED IN ANY FORM OR MANNER WHATSOEVER, NOR ARE THEY TO BE ASSIGNED TO ANY THIRD PARTY WITHOUT FIRST OBTAINING THE EXPRESSED WRITTEN PERMISSION AND CONSENT OF MODEL ENERGY, PLLC.

CLIENT:



ISSUED FOR:

DATE:

CONSTRUCTION

7/27/2023

LABELS,
DETAILS & SPECS

PV5.1



DATA SHEET



IQ8 Series Microinverters

Our newest IQ8 Microinverters are the industry's first microgrid-forming, software-defined microinverters with split-phase power conversion capability to convert DC power to AC power efficiently. The brain of the semiconductor-based microinverter is our proprietary application-specific integrated circuit (ASIC) which enables the microinverter to operate in grid-tied or off-grid modes. This chip is built in advanced 55nm technology with high speed digital logic and has super-fast response times to changing loads and grid events, alleviating constraints on battery sizing for home energy systems.



Part of the Enphase Energy System, IQ8 Series Microinverters integrate with the Enphase IQ Battery, Enphase IQ Gateway, and the Enphase App monitoring and analysis software.



IQ8 Series Microinverters redefine reliability standards with more than one million cumulative hours of power-on testing, enabling an industry-leading limited warranty of up to 25 years.



Connect PV modules quickly and easily to IQ8 Series Microinverters using the included Q-DCC-2 adapter cable with plug-n-play MC4 connectors.



IQ8 Series Microinverters are UL Listed as PV Rapid Shut Down Equipment and conform with various regulations, when installed according to manufacturer's instructions.

© 2021 Enphase Energy. All rights reserved. Enphase, the Enphase logo, IQ8 microinverters, and other names are trademarks of Enphase Energy, Inc. Data subject to change.

IQ8SE-DS-0001-01-EN-US-2021-10-19

Easy to install

- Lightweight and compact with plug-n-play connectors
- Power Line Communication (PLC) between components
- Faster installation with simple two-wire cabling

High productivity and reliability

- Produce power even when the grid is down
- More than one million cumulative hours of testing
- Class II double-insulated enclosure
- Optimized for the latest high-powered PV modules

Microgrid-forming

- Complies with the latest advanced grid support
- Remote automatic updates for the latest grid requirements
- Configurable to support a wide range of grid profiles
- Meets CA Rule 21 (UL 1741-SA) requirements

IQ8 Series Microinverters

INPUT DATA [DC]		IQ8-60-2-US	IQ8PLUS-72-2-US	IQ8M-72-2-US	IQ8A-72-2-US	IQ8H-240-72-2-US	IQ8H-208-72-2-US ¹
Commonly used module pairings ²	W	235 – 350	235 – 440	260 – 460	295 – 500	320 – 540+	295 – 500+
Module compatibility		60-cell/120 half-cell		60-cell/120 half-cell and 72-cell/144 half-cell			
MPPT voltage range	V	27 – 37	29 – 45	33 – 45	36 – 45	38 – 45	38 – 45
Operating range	V	25 – 48		25 – 58			
Min/max start voltage	V	30 / 48		30 / 58			
Max input DC voltage	V	50		60			
Max DC current ³ [module Isc]	A			15			
Overtoltage class DC port				II			
DC port backfeed current	mA			0			
PV array configuration		1x1 Ungrounded array; No additional DC side protection required; AC side protection requires max 20A per branch circuit					
OUTPUT DATA [AC]		IQ8-60-2-US	IQ8PLUS-72-2-US	IQ8M-72-2-US	IQ8A-72-2-US	IQ8H-240-72-2-US	IQ8H-208-72-2-US
Peak output power	VA	245	300	330	366	384	366
Max continuous output power	VA	240	290	325	349	380	360
Nominal (L-L) voltage/range ⁴	V	240 / 211 – 264				208 / 183 – 250	
Max continuous output current	A	1.0	1.21	1.35	1.45	1.58	1.73
Nominal frequency	Hz	60					
Extended frequency range	Hz	50 – 68					
Max units per 20 A (L-L) branch circuit ⁵		16	13	11	11	10	9
Total harmonic distortion		<5%					
Overtoltage class AC port		III					
AC port backfeed current	mA	30					
Power factor setting		1.0					
Grid-tied power factor (adjustable)		0.85 leading – 0.85 lagging					
Peak efficiency	%	97.5	97.6	97.6	97.6	97.6	97.4
CEC weighted efficiency	%	97	97	97	97.5	97	97
Night-time power consumption	mW	60					
MECHANICAL DATA							
Ambient temperature range		-40°C to +60°C (-40°F to +140°F)					
Relative humidity range		4% to 100% (condensing)					
DC Connector type		MC4					
Dimensions (HxWxD)		212 mm (8.3") x 175 mm (6.9") x 30.2 mm (1.2")					
Weight		1.08 kg (2.38 lbs)					
Cooling		Natural convection – no fans					
Approved for wet locations		Yes					
Acoustic noise at 1 m		<60 dBA					
Pollution degree		PD3					
Enclosure		Class II double-insulated, corrosion resistant polymeric enclosure					
Environ. category / UV exposure rating		NEMA Type 6 / outdoor					
COMPLIANCE							
Certifications		CA Rule 21 (UL 1741-SA), UL 62109-1, UL1741/IEE1547, FCC Part 15 Class B, ICES-0003 Class B, CAN/CSA-C22.2 NO. 107.1-01					
		This product is UL Listed as PV Rapid Shut Down Equipment and conforms with NEC 2014, NEC 2017, and NEC 2020 section 690.12 and C22.1-2018 Rule 64-218 Rapid Shutdown of PV Systems, for AC and DC conductors, when installed according to manufacturer's instructions.					

(1) The IQ8H-208 variant will be operating in grid-tied mode only at 208V AC. (2) No enforced DC/AC ratio. See the compatibility calculator at <https://link.enphase.com/module-compatibility> (3) Maximum continuous input DC current is 10.6A (4) Nominal voltage range can be extended beyond nominal if required by the utility. (5) Limits may vary. Refer to local requirements to define the number of microinverters per branch in your area.

IQ8SE-DS-0001-01-EN-US-2021-10-19

ENGINEER:

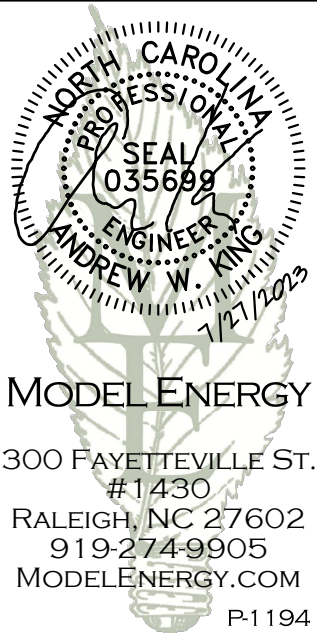

MODEL ENERGY
 300 FAYETTEVILLE ST.
 #1430
 RALEIGH, NC 27602
 919-274-9905
 MODELENERGY.COM
 P-1194

JOB TITLE:

NEW SOLAR PV SYSTEM

4.740 kW DC INPUT
 3.900 kW AC EXPORT

Cynetta Mitchell
 171 Barnsley Rd,
 Angier, NC 27501

© 2023 MODEL ENERGY, PLLC EXPRESSLY RESERVES ITS COMMON LAW COPYRIGHT AND OTHER PROPERTY RIGHTS IN THESE PLANS. THESE PLANS ARE NOT TO BE REPRODUCED, CHANGED OR COPIED IN ANY FORM OR MANNER WHATSOEVER, NOR ARE THEY TO BE ASSIGNED TO ANY THIRD PARTY WITHOUT FIRST OBTAINING THE EXPRESSED WRITTEN PERMISSION AND CONSENT OF MODEL ENERGY, PLLC.

CLIENT:



ISSUED FOR: DATE:

CONSTRUCTION 7/27/2023

EQUIPMENT SPEC SHEETS

PV5.2

Enphase IQ Combiner 4/4C

X-IQ-AM1-240-4
X-IQ-AM1-240-4C



X-IQ-AM1-240-4C

X-IQ-AM1-240-4



To learn more about Enphase offerings, visit enphase.com

The **Enphase IQ Combiner 4/4C** with Enphase IQ Gateway and integrated LTE-M1 cell modem (included only with IQ Combiner 4C) consolidates interconnection equipment into a single enclosure and streamlines IQ microinverters and storage installations by providing a consistent, pre-wired solution for residential applications. It offers up to four 2-pole input circuits and Eaton BR series busbar assembly.

Smart

- Includes IQ Gateway for communication and control
- Includes Enphase Mobile Connect cellular modem (CELLMODEM-M1-06-SP-05), included only with IQ Combiner 4C
- Includes solar shield to match Enphase IQ Battery aesthetics and deflect heat
- Flexible networking supports Wi-Fi, Ethernet, or cellular
- Optional AC receptacle available for PLC bridge
- Provides production metering and consumption monitoring

Simple

- Centered mounting brackets support single stud mounting
- Supports bottom, back and side conduit entry
- Up to four 2-pole branch circuits for 240 VAC plug-in breakers (not included)
- 80A total PV or storage branch circuits

Reliable

- Durable NRTL-certified NEMA type 3R enclosure
- Five-year limited warranty
- Two years labor reimbursement program coverage included for both the IQ Combiner SKU's
- UL listed



Enphase IQ Combiner 4/4C

MODEL NUMBER	
IQ Combiner 4 (X-IQ-AM1-240-4)	IQ Combiner 4 with Enphase IQ Gateway printed circuit board for integrated revenue grade PV production metering (ANSI C12.20 +/- 0.5%) and consumption monitoring (+/- 2.5%). Includes a silver solar shield to match the IQ Battery system and IQ System Controller 2 and to deflect heat.
IQ Combiner 4C (X-IQ-AM1-240-4C)	IQ Combiner 4C with Enphase IQ Gateway printed circuit board for integrated revenue grade PV production metering (ANSI C12.20 +/- 0.5%) and consumption monitoring (+/- 2.5%). Includes Enphase Mobile Connect cellular modem (CELLMODEM-M1-06-SP-05), a plug-and-play industrial-grade cell modem for systems up to 60 microinverters. (Available in the US, Canada, Mexico, Puerto Rico, and the US Virgin Islands, where there is adequate cellular service in the installation area.) Includes a silver solar shield to match the IQ Battery and IQ System Controller and to deflect heat.
ACCESSORIES AND REPLACEMENT PARTS (not included, order separately)	
Ensemble Communications Kit COMMS-CELLMODEM-M1-06 CELLMODEM-M1-06-SP-05 CELLMODEM-M1-06-AT-05	- Includes COMMS-KIT-01 and CELLMODEM-M1-06-SP-05 with 5-year Sprint data plan for Ensemble sites - 4G based LTE-M1 cellular modem with 5-year Sprint data plan - 4G based LTE-M1 cellular modem with 5-year AT&T data plan
Circuit Breakers BRK-10A-2-240V BRK-15A-2-240V BRK-20A-2P-240V BRK-15A-2P-240V-B BRK-20A-2P-240V-B	Supports Eaton BR210, BR215, BR220, BR230, BR240, BR250, and BR260 circuit breakers. Circuit breaker, 2 pole, 10A, Eaton BR210 Circuit breaker, 2 pole, 15A, Eaton BR215 Circuit breaker, 2 pole, 20A, Eaton BR220 Circuit breaker, 2 pole, 15A, Eaton BR215B with hold down kit support Circuit breaker, 2 pole, 20A, Eaton BR220B with hold down kit support
EPLC-01	Power line carrier (communication bridge pair), quantity - one pair
XA-SOLARSHIELD-ES	Replacement solar shield for IQ Combiner 4/4C
XA-PLUG-120-3	Accessory receptacle for Power Line Carrier in IQ Combiner 4/4C (required for EPLC-01)
XA-ENV-PCBA-3	Replacement IQ Gateway printed circuit board (PCB) for Combiner 4/4C
X-IQ-NA-HD-125A	Hold down kit for Eaton circuit breaker with screws.
ELECTRICAL SPECIFICATIONS	
Rating	Continuous duty
System voltage	120/240 VAC, 60 Hz
Eaton BR series busbar rating	125 A
Max. continuous current rating	65 A
Max. continuous current rating (input from PV/storage)	64 A
Max. fuse/circuit rating (output)	90 A
Branch circuits (solar and/or storage)	Up to four 2-pole Eaton BR series Distributed Generation (DG) breakers only (not included)
Max. total branch circuit breaker rating (input)	80A of distributed generation / 95A with IQ Gateway breaker included
Production metering CT	200 A solid core pre-installed and wired to IQ Gateway
Consumption monitoring CT (CT-200-SPLIT)	A pair of 200 A split core current transformers
MECHANICAL DATA	
Dimensions (WxHxD)	37.5 x 49.5 x 16.8 cm (14.75" x 19.5" x 6.63"). Height is 21.06" (53.5 cm) with mounting brackets.
Weight	7.5 kg (16.5 lbs)
Ambient temperature range	-40° C to +46° C (-40° to 115° F)
Cooling	Natural convection, plus heat shield
Enclosure environmental rating	Outdoor, NRTL-certified, NEMA type 3R, polycarbonate construction
Wire sizes	• 20 A to 50 A breaker inputs: 14 to 4 AWG copper conductors • 60 A breaker branch input: 4 to 1/0 AWG copper conductors • Main lug combined output: 10 to 2/0 AWG copper conductors • Neutral and ground: 14 to 1/0 copper conductors Always follow local code requirements for conductor sizing.
Altitude	To 2000 meters (6,560 feet)
INTERNET CONNECTION OPTIONS	
Integrated Wi-Fi	802.11b/g/n
Cellular	CELLMODEM-M1-06-SP-05, CELLMODEM-M1-06-AT-05 (4G based LTE-M1 cellular modem). Note that an Enphase Mobile Connect cellular modem is required for all Ensemble installations.
Ethernet	Optional, 802.3, Cat5E (or Cat 6) UTP Ethernet cable (not included)
COMPLIANCE	
Compliance, IQ Combiner	UL 1741, CAN/CSA C22.2 No. 107.1, 47 CFR, Part 15, Class B, ICES 003 Production metering: ANSI C12.20 accuracy class 0.5 (PV production) Consumption metering: accuracy class 2.5
Compliance, IQ Gateway	UL 60601-1/CANCSA 22.2 No. 61010-1

To learn more about Enphase offerings, visit enphase.com

© 2021 Enphase Energy. All rights reserved. Enphase, the Enphase logo, IQ Combiner 4/4C, and other names are trademarks of Enphase Energy, Inc. Data subject to change. 10-21-2021



ENGINEER:

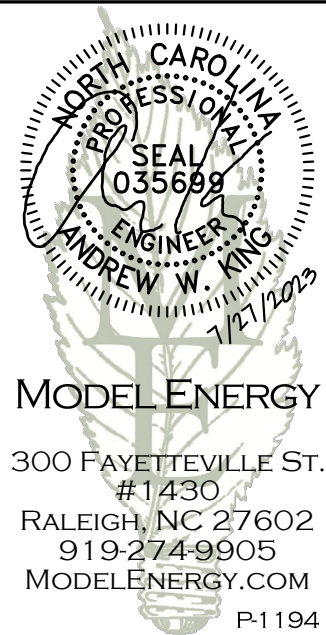

MODEL ENERGY
300 FAYETTEVILLE ST.
#1430
RALEIGH, NC 27602
919-274-9905
MODELENERGY.COM
P-1194

JOB TITLE:

NEW SOLAR PV SYSTEM

4.740 kW DC INPUT
3.900 kW AC EXPORT

Cynetta Mitchell
171 Barnsley Rd,
Angier, NC 27501

© 2023 MODEL ENERGY, PLLC EXPRESSLY RESERVES ITS COMMON LAW COPYRIGHT AND OTHER PROPERTY RIGHTS IN THESE PLANS. THESE PLANS ARE NOT TO BE REPRODUCED, CHANGED OR COPIED IN ANY FORM OR MANNER WHATSOEVER, NOR ARE THEY TO BE ASSIGNED TO ANY THIRD PARTY WITHOUT FIRST OBTAINING THE EXPRESSED WRITTEN PERMISSION AND CONSENT OF MODEL ENERGY, PLLC.

CLIENT:



ISSUED FOR:	DATE:
CONSTRUCTION	7/27/2023

EQUIPMENT
SPEC SHEETS

PV5.3

DESCRIPTION:
SNAPNRACK, ULTRA RAIL ALL PURPOSE L FOOT
(90 DEG)

PART NUMBER(S):
242-01223, 242-01239

DRAWN BY:
mwatkins
REVISION:
C

SnapNrack®
595 MARKET STREET, 29TH FLOOR • SAN FRANCISCO, CA 94105 USA
PHONE (415) 580-6900 • FAX (415) 580-6902
THE INFORMATION IN THIS DRAWING IS CONFIDENTIAL AND PROPRIETARY. ANY REPRODUCTION, DISCLOSURE, OR USE THEREOF IS PROHIBITED WITHOUT THE WRITTEN CONSENT OF SUNRUN SOUTH LLC.

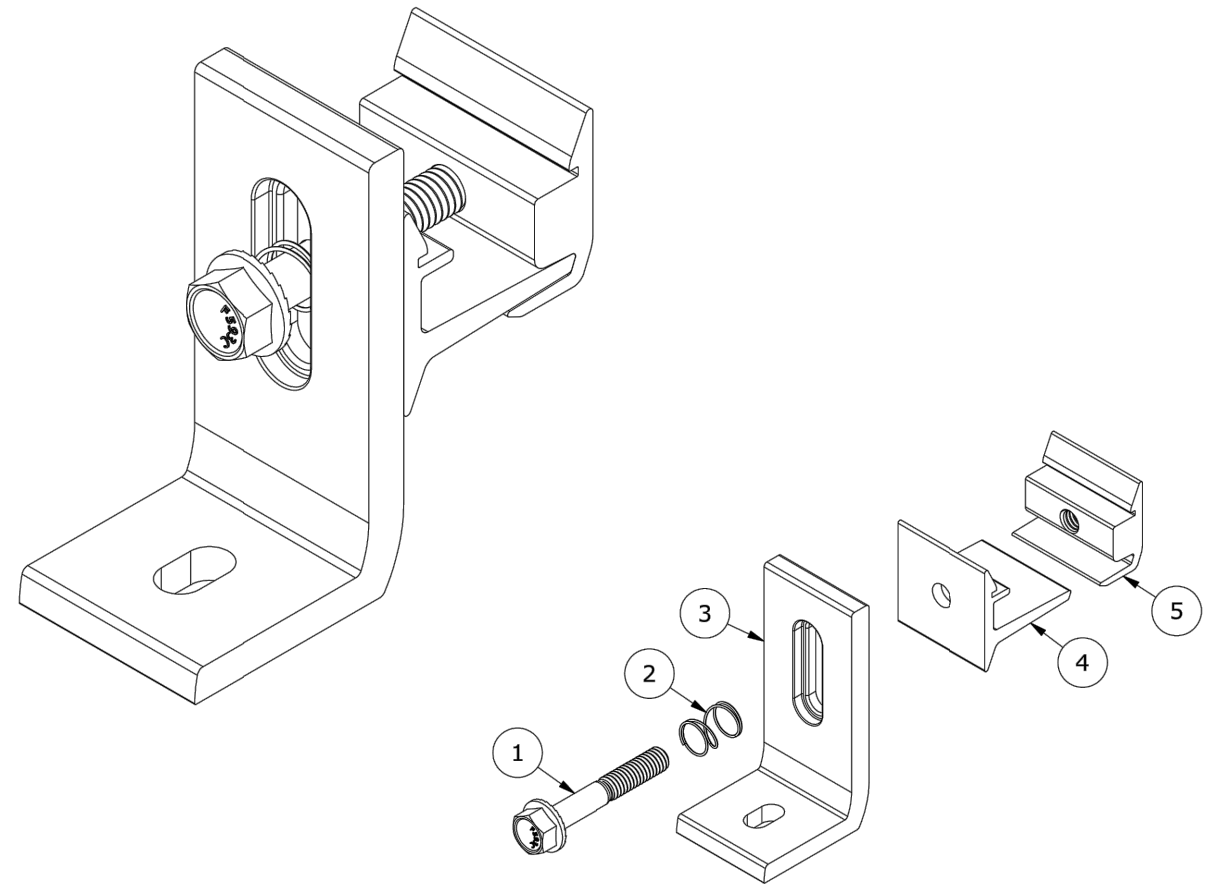

PARTS LIST		
ITEM	QTY	DESCRIPTION
1	1	BOLT, FLANGE, SERRATED, 5/16IN-18 X 2IN, SS
2	1	SNAPNRACK, RL UNIVERSAL, MOUNT SPRING, SS
3	1	SNAPNRACK, AP90 L FOOT, STEPPED, SILVER / BLACK
4	1	SNAPNRACK, ULTRA RAIL MOUNT THRU PRC, SILVER / BLACK
5	1	SNAPNRACK, ULTRA RAIL MOUNT TAPPED PRC, SILVER / BLACK

MATERIALS:	6000 SERIES ALUMINUM, STAINLESS STEEL	OPTIONS:
DESIGN LOAD (LBS):	405 UP, 788 DOWN, 213 SIDE	SILVER / BLACK ANODIZED
ULTIMATE LOAD (LBS):	N/A	
TORQUE SPECIFICATION:	12 LB-FT	
CERTIFICATION:	UL 2703, FILE E359313	
WEIGHT (LBS):	0.36	

DESCRIPTION:
SNAPNRACK, ULTRA RAIL ALL PURPOSE L FOOT
(90 DEG)

PART NUMBER(S):
242-01223, 242-01239

DRAWN BY:
mwatkins
REVISION:
C

SnapNrack®
595 MARKET STREET, 29TH FLOOR • SAN FRANCISCO, CA 94105 USA
PHONE (415) 580-6900 • FAX (415) 580-6902
THE INFORMATION IN THIS DRAWING IS CONFIDENTIAL AND PROPRIETARY. ANY REPRODUCTION, DISCLOSURE, OR USE THEREOF IS PROHIBITED WITHOUT THE WRITTEN CONSENT OF SUNRUN SOUTH LLC.

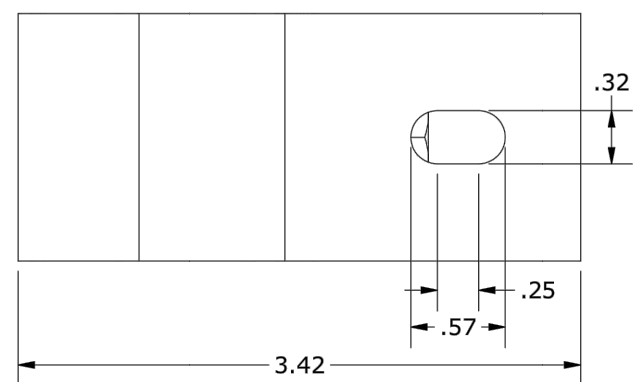
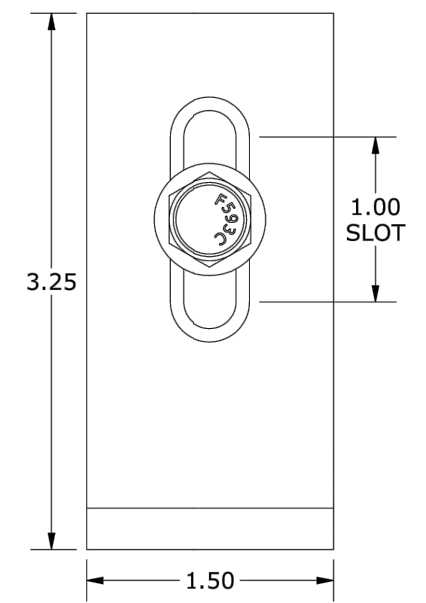
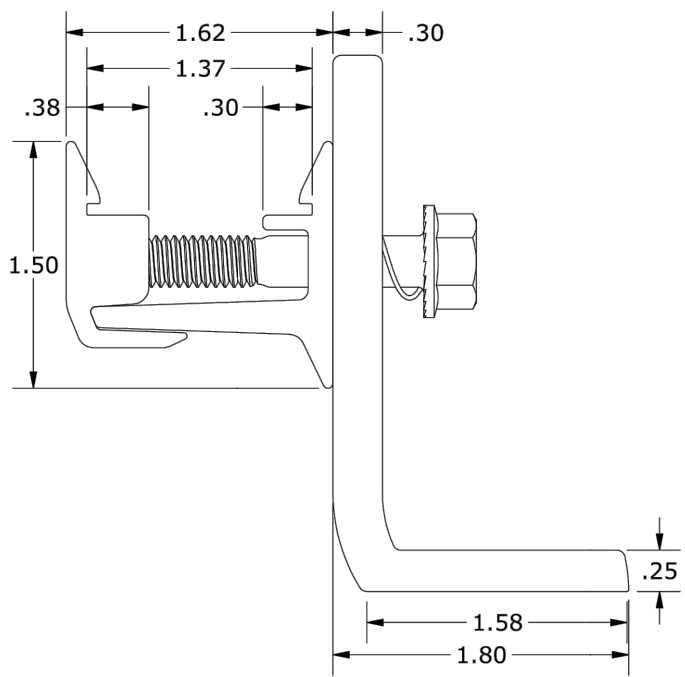

ALL DIMENSIONS IN INCHES

ENGINEER:

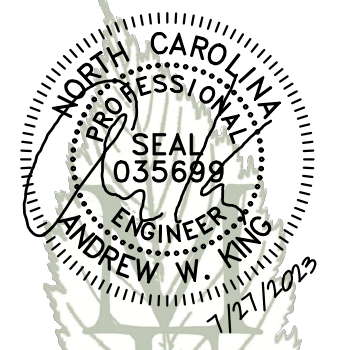

MODEL ENERGY
300 FAYETTEVILLE ST.
#1430
RALEIGH, NC 27602
919-274-9905
MODELENERGY.COM
P-1194

JOB TITLE:

NEW SOLAR PV SYSTEM
4.740 kW DC INPUT
3.900 kW AC EXPORT
Cynetta Mitchell
171 Barnsley Rd,
Angier, NC 27501

© 2023 MODEL ENERGY, PLLC EXPRESSLY RESERVES ITS COMMON LAW COPYRIGHT AND OTHER PROPERTY RIGHTS IN THESE PLANS. THESE PLANS ARE NOT TO BE REPRODUCED, CHANGED OR COPIED IN ANY FORM OR MANNER WHATSOEVER, NOR ARE THEY TO BE ASSIGNED TO ANY THIRD PARTY WITHOUT FIRST OBTAINING THE EXPRESSED WRITTEN PERMISSION AND CONSENT OF MODEL ENERGY, PLLC.

CLIENT:



ISSUED FOR: CONSTRUCTION DATE: 7/27/2023

EQUIPMENT SPEC SHEETS

PV5.4

DESCRIPTION:
SNAPNRACK, UR-40 RAIL

DRAWN BY:
mwatkins



PART NUMBER(S):
232-02449, 232-02450, 232-02451

REVISION:
B

595 MARKET STREET, 29TH FLOOR • SAN FRANCISCO, CA 94105 USA
PHONE (415) 580-6900 • FAX (415) 580-6902
THE INFORMATION IN THIS DRAWING IS CONFIDENTIAL AND PROPRIETARY. ANY REPRODUCTION, DISCLOSURE, OR USE THEREOF IS PROHIBITED WITHOUT THE WRITTEN CONSENT OF SUNRUN SOUTH LLC.

UR-40 RAIL PROPERTIES	
SKU	FINISH
232-02449	MILL
232-02450	CLEAR
232-02451	BLACK

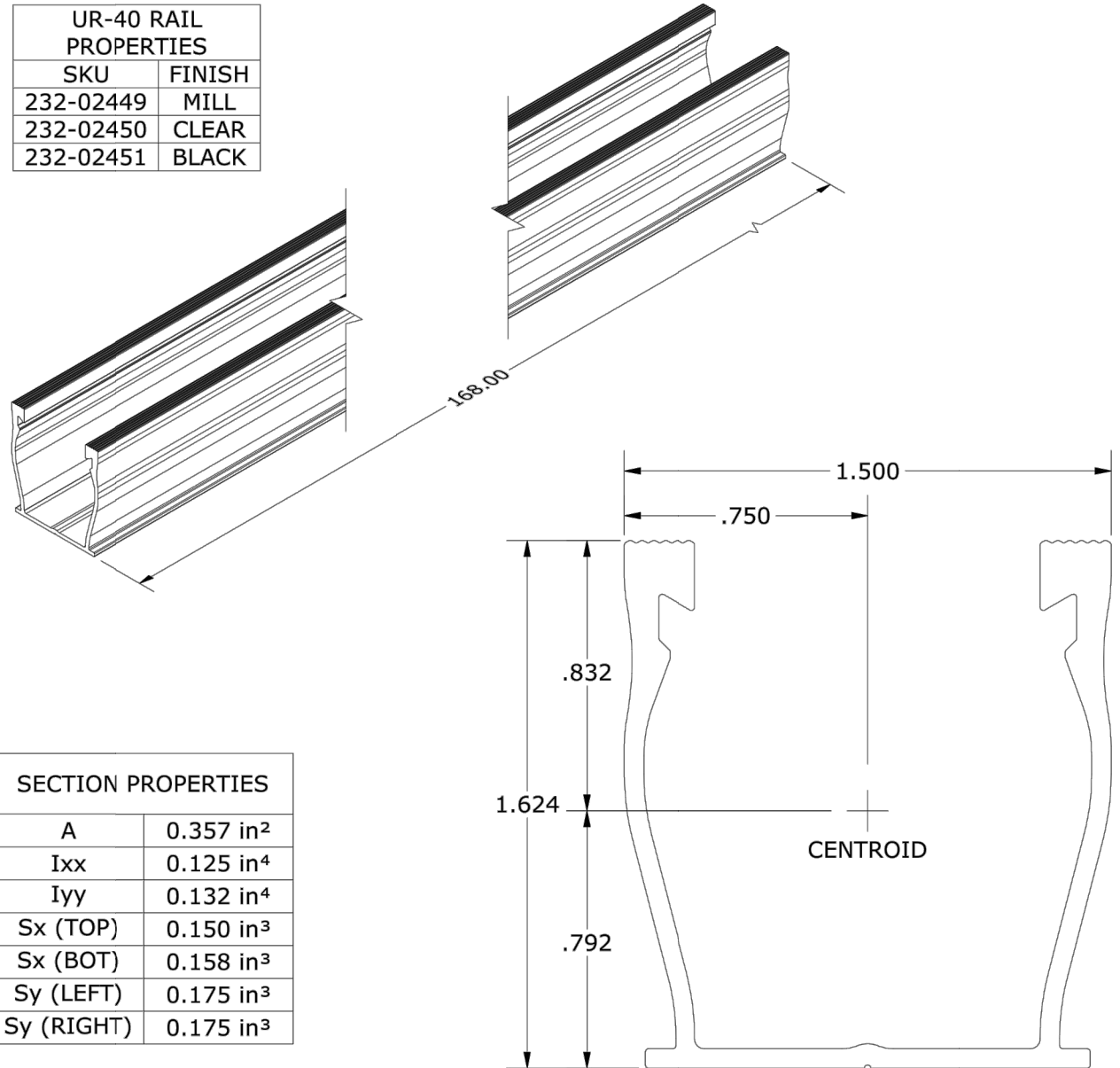

SECTION PROPERTIES	
A	0.357 in ²
I _{xx}	0.125 in ⁴
I _{yy}	0.132 in ⁴
S _x (TOP)	0.150 in ³
S _x (BOT)	0.158 in ³
S _y (LEFT)	0.175 in ³
S _y (RIGHT)	0.175 in ³

ALL DIMENSIONS IN INCHES

MATERIALS:	6000 SERIES ALUMINUM	OPTIONS:
DESIGN LOAD (LBS):	N/A	CLEAR / BLACK ANODIZED
ULTIMATE LOAD (LBS):	N/A	MILL FINISH
TORQUE SPECIFICATION:	N/A LB-FT	BUNDLES OF 144
CERTIFICATION:	UL 2703, FILE E359313	BOXES OF 8
WEIGHT (LBS):	5.85	

ENGINEER:

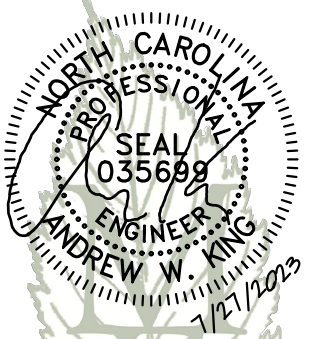

MODEL ENERGY
300 FAYETTEVILLE ST.
#1430
RALEIGH, NC 27602
919-274-9905
MODELENERGY.COM
P-1194

JOB TITLE:

NEW SOLAR PV SYSTEM
4.740 kW DC INPUT
3.900 kW AC EXPORT

Cynetta Mitchell
171 Barnsley Rd,
Angier, NC 27501

© 2023 MODEL ENERGY, PLLC EXPRESSLY RESERVES ITS COMMON LAW COPYRIGHT AND OTHER PROPERTY RIGHTS IN THESE PLANS. THESE PLANS ARE NOT TO BE REPRODUCED, CHANGED OR COPIED IN ANY FORM OR MANNER WHATSOEVER, NOR ARE THEY TO BE ASSIGNED TO ANY THIRD PARTY WITHOUT FIRST OBTAINING THE EXPRESSED WRITTEN PERMISSION AND CONSENT OF MODEL ENERGY, PLLC.

CLIENT:



ISSUED FOR:	DATE:
CONSTRUCTION	7/27/2023

EQUIPMENT SPEC SHEETS

PV5.5

Customer: Cynetta Mitchell
Installer: Emerald Energy
Subject: PV System Structural Compliance
Date: 7/27/2023

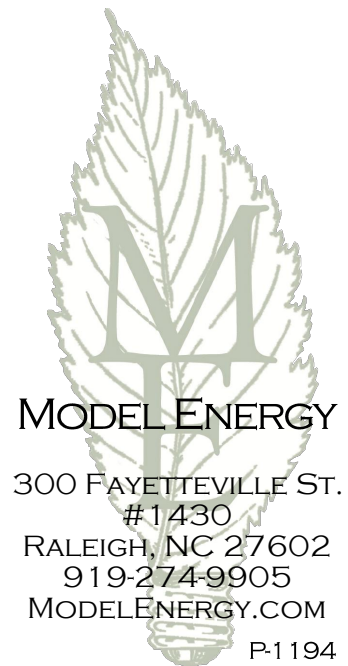

To whom it may concern:

Model Energy, PLLC has reviewed the installation details of the proposed PV system that is to be installed by Emerald Energy at 171 Barnsley Rd, Angier, NC 27501. The conditions of the existing structure have been reviewed and validated by Model Energy, PLLC. The existing roof structure has been designed to support the additional loads of the proposed PV system. In addition, the racking and fastening system shall be capable of securing the system to the structure under design conditions when installed properly and in accordance with the racking and fastening arrangement detailed within the accompanying permit set. The installation design is compliant with current 2018 North Carolina state and national building codes.

Thank you,

Andrew King, PE

