



Freedom Forever  
Planset Revision Letter

6/5/2023  
REV #1

Attn. Harnett County (NC):

The changes outlined in Revision Details have been applied to the plans corresponding to the following customer:

WILLIE MATTHEWS  
400 EAST I STREET, ERWIN, NC 28339

**Revision Details:**

REV1 - 6-5-23 - Layout updated.

All corresponding changes are notated on the plans by revision clouds.

Thank you for your time in reviewing these plans. Please reach out if you have any additional questions or concerns.

Construction Engineering  
Freedom Forever  
[engineering@freedomforever.com](mailto:engineering@freedomforever.com)

# ROOF MOUNT PHOTOVOLTAIC SYSTEM

**CODES:**

THIS PROJECT COMPLIES WITH THE FOLLOWING:  
 2018 NORTH CAROLINA BUILDING CODE  
 2018 NORTH CAROLINA RESIDENTIAL CODE  
 2018 NORTH CAROLINA PLUMBING CODE  
 2018 NORTH CAROLINA MECHANICAL CODE  
 2018 NORTH CAROLINA FUEL GAS CODE  
 2017 NATIONAL ELECTRICAL CODE  
 AS ADOPTED BY HARNETT COUNTY (NC)

**CONSTRUCTION NOTES:**

CONDUIT AND CONDUCTOR SPECIFICATIONS ARE BASED ON MINIMUM CODE REQUIREMENTS AND ARE NOT MEANT TO LIMIT UP-SIZING AS REQUIRED BY FIELD CONDITIONS.

ALL SOLAR ENERGY SYSTEM EQUIPMENT SHALL BE SCREENED TO THE MAXIMUM EXTENT POSSIBLE AND SHALL BE PAINTED A COLOR SIMILAR TO THE SURFACE UPON WHICH THEY ARE MOUNTED.

MODULES SHALL BE TESTED , LISTED AND IDENTIFIED WITH FIRE CLASSIFICATION IN ACCORDANCE WITH UL 2703. SMOKE AND CARBON MONOXIDE ALARMS ARE REQUIRED PER SECTION R314 AND 315 TO BE VERIFIED AND INSPECTED BY INSPECTOR IN THE FIELD.

DIG ALERT (811) TO BE CONTACTED AND COMPLIANCE WITH EXCAVATION SAFETY PRIOR TO ANY EXCAVATION TAKING PLACE

PHOTOVOLTAIC SYSTEM GROUND WILL BE TIED INTO EXISTING GROUND AT MAIN SERVICE FROM DC DISCONNECT/INVERTER AS PER 2017 NEC SEC 250.166(A).

SOLAR PHOTOVOLTAIC SYSTEM EQUIPMENT WILL BE INSTALLED IN ACCORDANCE WITH REQUIREMENTS OF ART. 690 OF THE 2017 NEC

THE MAIN SERVICE PANEL WILL BE EQUIPPED WITH A GROUND ROD OR UFER

UTILITY COMPANY WILL BE NOTIFIED PRIOR TO ACTIVATION OF THE SOLAR PV SYSTEM

SOLAREEDGE OPTIMIZERS ARE LISTED TO IEC 62109-1 (CLASS II SAFETY) AND UL 1741 STANDARDS

INSTALL CREW TO VERIFY ROOF STRUCTURE PRIOR TO COMMENCING WORK. EMT CONDUIT ATTACHED TO THE ROOF USING CONDUIT MOUNT.

**VICINITY MAP:**

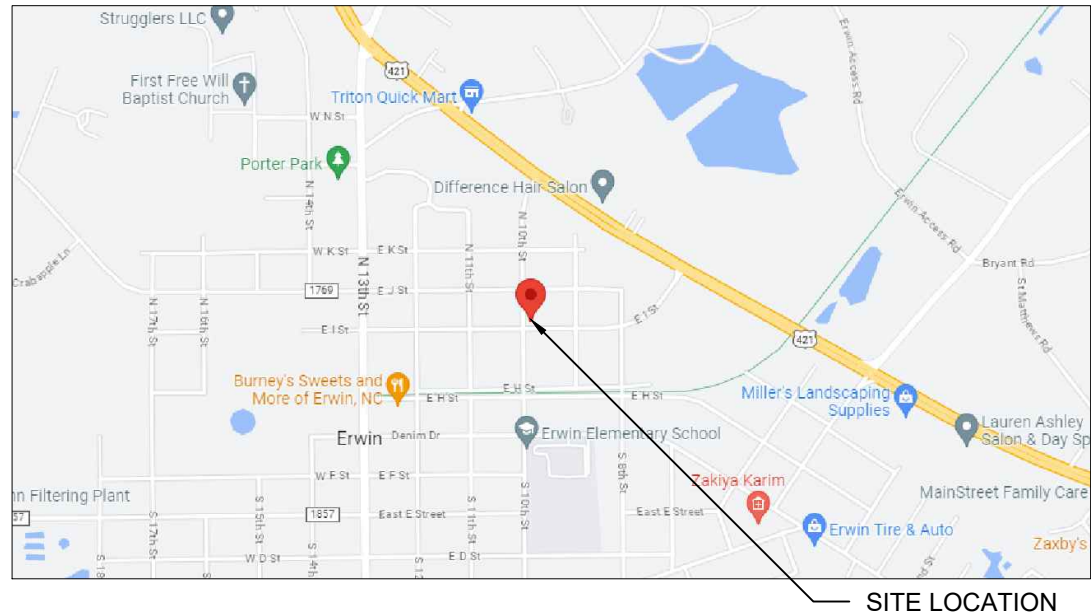

SITE LOCATION

**TABLE OF CONTENTS:**

PV-1	SITE LOCATION
PV-2	SITE PLAN
PV-2A	ROOF PLAN WITH MODULES LAYOUT
PV-2B	ROOF AND STRUCTURAL TABLES
PV-3	MOUNTING DETAILS
PV-4	THREE LINE DIAGRAM
PV-5	CONDUCTOR CALCULATIONS
PV-6	EQUIPMENT & SERVICE LIST
PV-7	LABELS
PV-7A	SITE PLACARD
PV-8	OPTIMIZER CHART
PV-9	SAFETY PLAN
PV-10	SAFETY PLAN
APPENDIX	MANUFACTURER SPECIFICATION SHEETS

**CLIENT:**  
 WILLIE MATTHEWS  
 400 EAST I STREET, ERWIN, NC 28339  
 AHJ: HARNETT COUNTY (NC)  
 UTILITY: DUKE ENERGY (NC)  
 METER: 332316907  
 PHONE: (910) 890-1153  
 EMAIL: BILLYSM13@GMAIL.COM  
 FINANCE: OTHER

**SYSTEM:**  
 SYSTEM SIZE (DC): 17 X 410 = 6.970 kW  
 SYSTEM SIZE (AC): 5.000 kW @ 240V  
 MODULES: 17 X REC SOLAR: REC410AA PURE-R  
 OPTIMIZERS: 17 X SOLAREEDGE P505  
 INVERTER: SOLAREEDGE SE5000H-USRGM [S11]

REVISIONS		
NO.	REVISED BY	DATE
-	-	-
-	-	-
-	-	-

NOTICE TO CONTRACTOR  
 All construction must comply with current NC Building Codes and is subject to field inspection and verification.

**APPROVED**  
Limited building only review  
 Permit holder responsible for full compliance with the code











07/03/2023

**FREEDOM FOREVER LLC**  
 415 INDUSTRIAL CT., GREER, SC 29651  
 Tel: (800) 385-1075

**GREG ALBRIGHT**

**CONTRACTOR LICENSE:**  
 ELECTRICAL CONTRACTOR U.34043

SITE LOCATION			
JOB NO:	DATE:	DESIGNED BY:	SHEET:
334165	6/5/2023	A.K.	PV-1

- LEGEND:**
-  CHIMNEY
  -  PIPE VENT
  -  MODULES
  -  CONDUIT
  -  SETBACK
  -  AC DISCONNECT
  -  MSP
  -  JUNCTION BOX
  -  INVERTER
  -  UTILITY METER
  -  MAIN BREAKER ENCLOSURE

**PV SYSTEM**  
 6.970 kW-DC  
 5.000 kW-AC

**THIS SYSTEM DESIGNED WITH:**  
 WIND SPEED: 130  
 WIND EXPOSURE: B  
 SNOW LOAD: 15

**TOTAL ROOF AREA RIDGE SETBACK CALCS:**  
 TOTAL ROOF AREA: 2192.49 SQ FT  
 SINGLE MODULE AREA: 20.81908296 SQ FT  
 TOTAL NUMBER OF MODULES: 17  
 TOTAL AREA OF MODULES: 353.92 SQ FT  
 ROOF COVERAGE: 16.14%  
 FIRE SPRINKLERS : NO

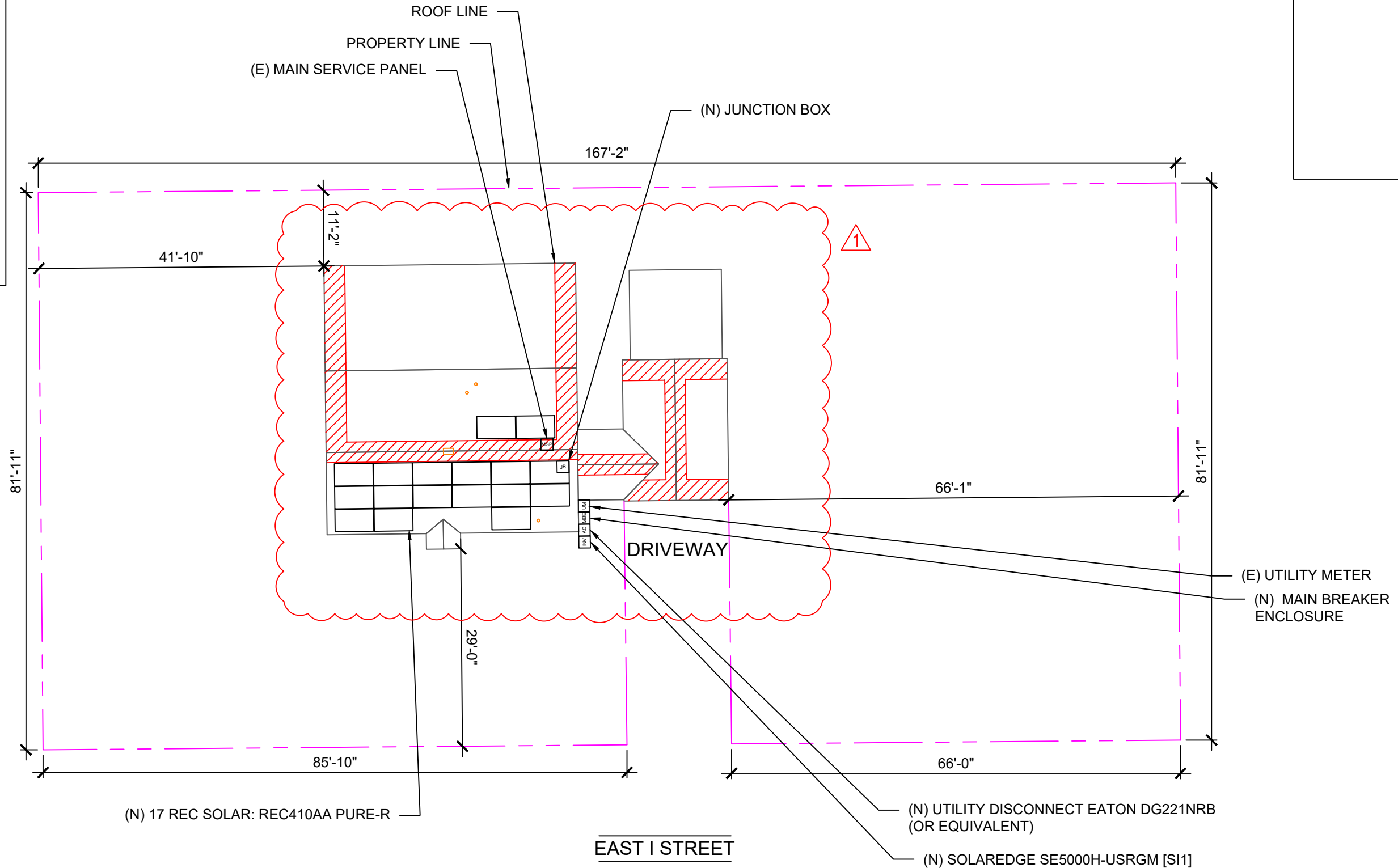

ROOF AREA: 2192.49 SQ FT

**CLIENT:**  
 WILLIE MATTHEWS  
 400 EAST I STREET, ERWIN, NC 28339  
 AHJ: HARNETT COUNTY (NC)  
 UTILITY: DUKE ENERGY (NC)  
 METER: 332316907  
 PHONE: (910) 890-1153  
 EMAIL: BILLYSM13@GMAIL.COM  
 FINANCE: OTHER

**SYSTEM:**  
 SYSTEM SIZE (DC): 17 X 410 = 6.970 kW  
 SYSTEM SIZE (AC): 5.000 kW @ 240V  
 MODULES: 17 X REC SOLAR: REC410AA PURE-R  
 OPTIMIZERS: 17 X SOLAREEDGE P505  
 INVERTER: SOLAREEDGE SE5000H-USRGM [SI1]

REVISIONS		
NO.	REVISED BY	DATE
-	-	-
-	-	-
-	-	-



**FREEDOM FOREVER LLC**  
 415 INDUSTRIAL CT., GREER, SC 29651  
 Tel: (800) 385-1075

GREG ALBRIGHT

*Greg Albright*  
 CONTRACTOR LICENSE:  
 ELECTRICAL CONTRACTOR U.34043



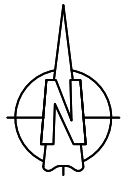







SITE PLAN			
JOB NO:	DATE:	DESIGNED BY:	SHEET:
334165	6/5/2023	A.K.	PV-2



**SITE PLAN**  
 SCALE: 1/16" = 1'-0"

1

LEGEND:

-  CHIMNEY
-  PIPE VENT
-  MODULES
-  CONDUIT
-  SETBACK
-  AC DISCONNECT
-  MSP
-  JUNCTION BOX
-  INVERTER
-  UTILITY METER
-  MAIN BREAKER ENCLOSURE

PV SYSTEM  
 6.970 kW-DC  
 5.000 kW-AC

THIS SYSTEM DESIGNED WITH:  
 WIND SPEED: 130  
 WIND EXPOSURE: B  
 SNOW LOAD: 15

TOTAL ROOF AREA: 2192.49 SQ FT  
 TOTAL ARRAY AREA: 353.92 SQ FT  
 ARRAY COVERAGE: 16.14%  
 SYSTEM DISTRIBUTED WEIGHT: 2.28 LBS  
 S-5!: PROTEA POINT-LOAD: 21.21 LBS

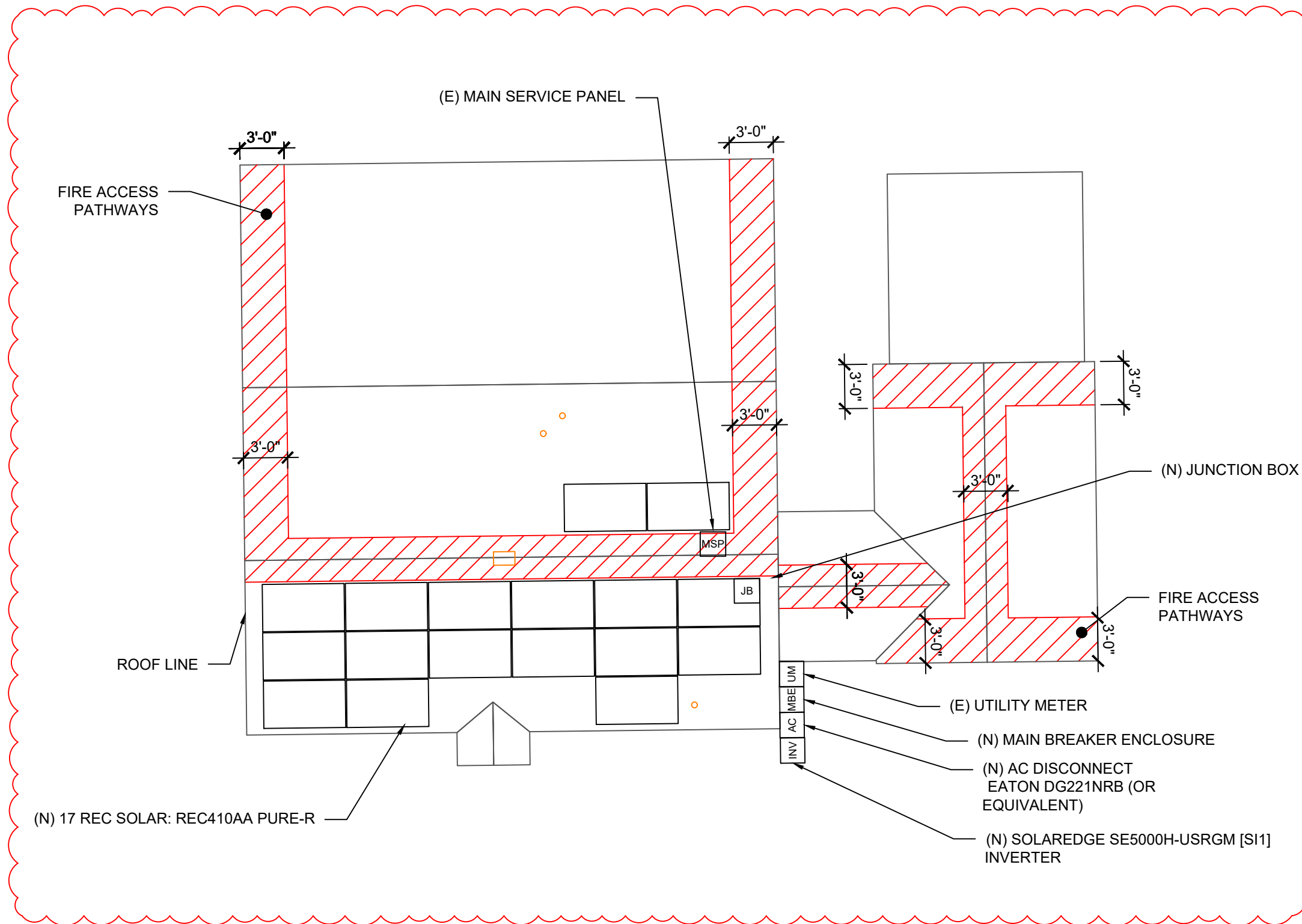

ROOF AREA: 2192.49 SQ FT

CLIENT:  
 WILLIE MATTHEWS  
 400 EAST I STREET, ERWIN, NC 28339  
 AHJ: HARNETT COUNTY (NC)  
 UTILITY: DUKE ENERGY (NC)  
 METER: 332316907  
 PHONE: (910) 890-1153  
 EMAIL: BILLYSM13@GMAIL.COM  
 FINANCE: OTHER

SYSTEM:  
 SYSTEM SIZE (DC): 17 X 410 = 6.970 kW  
 SYSTEM SIZE (AC): 5.000 kW @ 240V  
 MODULES: 17 X REC SOLAR: REC410AA PURE-R  
 OPTIMIZERS: 17 X SOLAREEDGE P505  
 INVERTER: SOLAREEDGE SE5000H-USRGM [S11]

REVISIONS		
NO.	REVISED BY	DATE
-	-	-
-	-	-
-	-	-



FREEDOM FOREVER LLC  
 415 INDUSTRIAL CT., GREER, SC 29651  
 Tel: (800) 385-1075

GREG ALBRIGHT

CONTRACTOR LICENSE:  
 ELECTRICAL CONTRACTOR U.34043

ROOF PLAN WITH MODULES LAYOUT

JOB NO: 334165	DATE: 6/5/2023	DESIGNED BY: A.K.	SHEET: PV-2A
-------------------	-------------------	----------------------	-----------------



ROOF PLAN  
 SCALE: 1/8" = 1'-0"

1

NOTES:

1. EMT CONDUIT ATTACHED TO THE ROOF USING CONDUIT MOUNTS
2. ATTACHED CLAMPS AT 25% FROM THE EDGE AND 50% FROM THE CENTER OF THE MODULES
3. JUNCTION BOX IS MOUNTED TO THE RAIL.



# ROOF DETAILS:

TOTAL ROOF AREA: 2192.49 SQ FT  
 TOTAL ARRAY AREA: 353.92 SQFT  
 ARRAY COVERAGE: 16.14%  
 SYSTEM DISTRIBUTED WEIGHT: 2.28 LBS  
 S-5I: PROTEA POINT-LOAD: 21.21 LBS



1

ROOF AREA STATEMENT						
ROOF	MODULE QUANTITY	ROOF PITCH	ARRAY PITCH	AZIMUTH	ROOF AREA	ARRAY AREA
ROOF 1	15	35	35	179	494.27 SQ FT	312.29 SQ FT
ROOF 2	2	35	35	359	495.61 SQ FT	41.64 SQ FT
----	----	----	----	----	SQ FT	SQ FT
----	----	----	----	----	SQ FT	SQ FT
----	----	----	----	----	SQ FT	SQ FT
----	----	----	----	----	SQ FT	SQ FT
----	----	----	----	----	SQ FT	SQ FT
----	----	----	----	----	SQ FT	SQ FT
----	----	----	----	----	SQ FT	SQ FT
----	----	----	----	----	SQ FT	SQ FT

**CLIENT:**  
 WILLIE MATTHEWS  
 400 EAST I STREET, ERWIN, NC 28339  
 AHJ: HARNETT COUNTY (NC)  
 UTILITY: DUKE ENERGY (NC)  
 METER: 332316907  
 PHONE: (910) 890-1153  
 EMAIL: BILLYSM13@GMAIL.COM  
 FINANCE: OTHER

**SYSTEM:**  
 SYSTEM SIZE (DC): 17 X 410 = 6.970 kW  
 SYSTEM SIZE (AC): 5.000 kW @ 240V  
 MODULES: 17 X REC SOLAR: REC410AA  
 PURE-R  
 OPTIMIZERS: 17 X SOLAREEDGE P505  
 INVERTER: SOLAREEDGE SE5000H-USRGM [S1]

REVISIONS		
NO.	REVISED BY	DATE
-	-	-
-	-	-
-	-	-



**FREEDOM FOREVER LLC**  
 415 INDUSTRIAL CT., GREER, SC 29651  
 Tel: (800) 385-1075

**GREG ALBRIGHT**



**CONTRACTOR LICENSE:**  
 ELECTRICAL CONTRACTOR U.34043

ROOF DETAILS			
JOB NO:	DATE:	DESIGNED BY:	SHEET:
334165	6/5/2023	A.K.	PV-2B

1

**TABLE 1 - ARRAY INSTALLATION**

	ROOF PITCH	ROOFING TYPE	ATTACHMENT TYPE	FRAMING TYPE <sup>1</sup>	MAX UNBRACED LENGTH(FT.) <sup>1</sup>	RAFTER/TRUSS SISTERING	PENETRATION PATTERN <sup>2</sup>	MAX ATTACHMENT SPACING (IN.) <sup>2</sup>	MAX RAIL OVERHANG(I N.) <sup>3</sup>
ROOF 1	35	METAL	S-5 PROTEABRACKET	2X6 RAFTER @ 16" OC	3.00'	NOT REQ'D	STAGGERED	48	16"
ROOF 2	35	METAL	S-5 PROTEABRACKET	2X6 RAFTER @ 16" OC	3.00'	NOT REQ'D	STAGGERED	48	16"
							0	0	
							0	0	
							0	0	
							0	0	
							0	0	
							0	0	
							0	0	
							0	0	

1. CONTRACTOR TO VERIFY FRAMING TYPE AND MAX UNBRACED LENGTH PRIOR TO INSTALLATION. IF THE ABOVE INFORMATION DOES NOT MATCH FIELD CONDITIONS, NOTIFY ENGINEER OF RECORD IMMEDIATELY.
2. WHERE COLLAR TIES OR RAFTER SUPPORTS EXIST, CONTRACTOR SHALL USE RAFTERS WITH COLLAR TIES AS ATTACHMENT POINTS.
3. WHERE APPLICABLE FOR RAILED ATTACHMENT INSTALLATIONS.

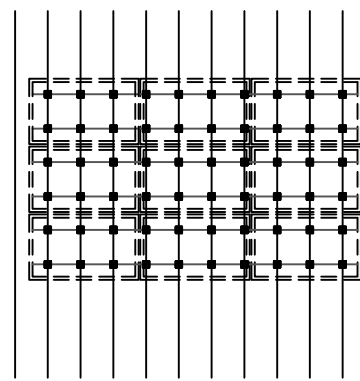

**STACKED DETAIL**  
For Illustration purposes only

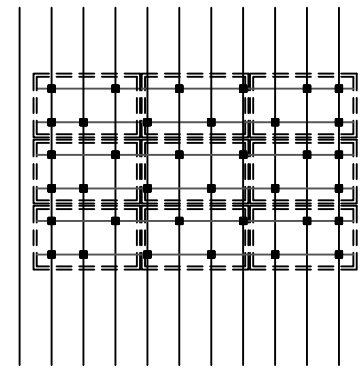

**STAGGERED DETAIL**  
For Illustration purposes only



**CLIENT:**  
WILLIE MATTHEWS  
400 EAST I STREET, ERWIN, NC 28339  
AHJ: HARNETT COUNTY (NC)  
UTILITY: DUKE ENERGY (NC)  
METER: 332316907  
PHONE: (910) 890-1153  
EMAIL: BILLYSM13@GMAIL.COM  
FINANCE: OTHER

**SYSTEM:**  
SYSTEM SIZE (DC): 17 X 410 = 6.970 kW  
SYSTEM SIZE (AC): 5.000 kW @ 240V  
MODULES: 17 X REC SOLAR: REC410AA PURE-R  
OPTIMIZERS: 17 X SOLAREEDGE P505  
INVERTER: SOLAREEDGE SE5000H-USRGM [S11]

REVISIONS		
NO.	REVISED BY	DATE
-	-	-
-	-	-
-	-	-

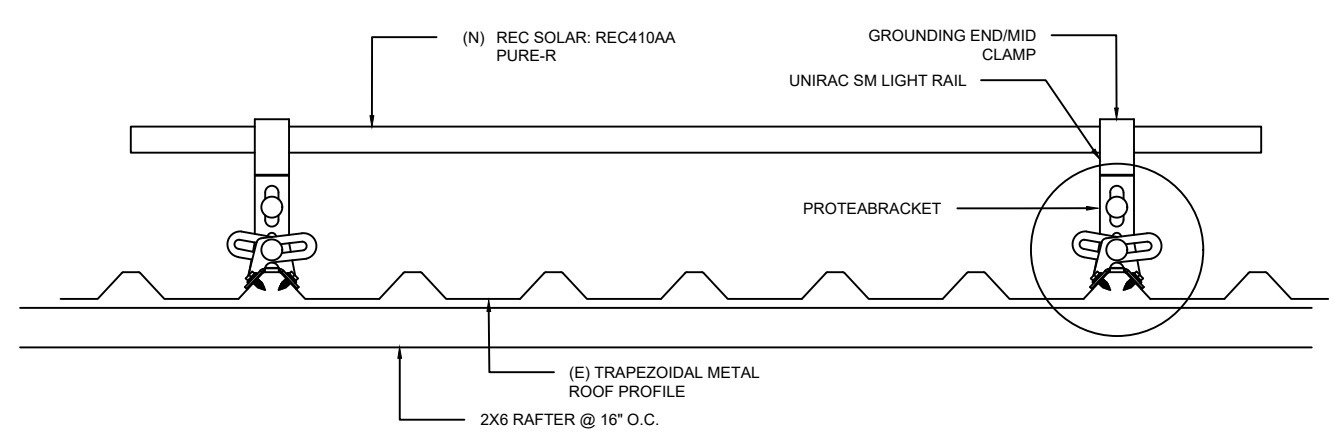

**SOLAR PV ARRAY SECTION VIEW**  
Scale: NTS

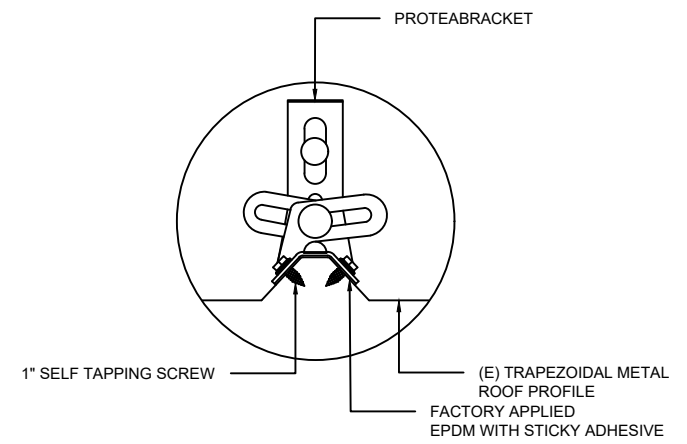

**ATTACHMENT DETAIL**  
Scale: NTS

**freedom FOREVER**  
FREEDOM FOREVER LLC  
415 INDUSTRIAL CT., GREER, SC 29651  
Tel: (800) 385-1075  
**GREG ALBRIGHT**  
*Greg Albright*  
CONTRACTOR LICENSE:  
ELECTRICAL CONTRACTOR U.34043

MOUNTING DETAILS			
JOB NO:	DATE:	DESIGNED BY:	SHEET:
334165	6/5/2023	A.K.	PV-3

BACKFEED FUSE SIZING					
MAX. CONTINUOUS OUTPUT 21.00A @ 240V					
21.00	X	1.25	=	26AMPS	30A FUSES - OK

PV SYSTEM  
 6.970 kW-DC  
 5.000 kW-AC

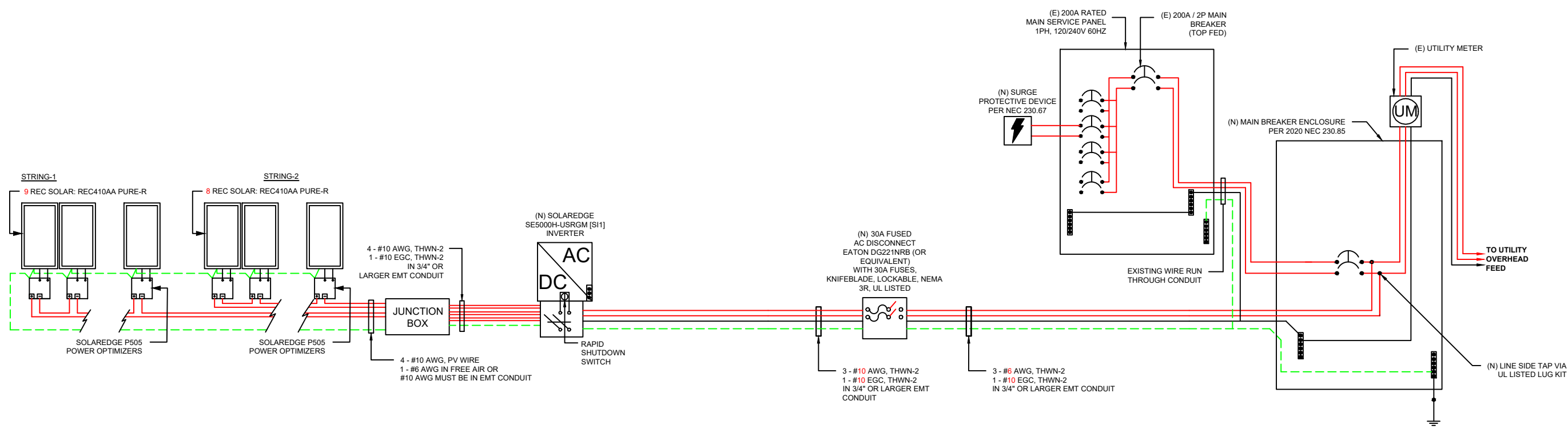

CLIENT:  
 WILLIE MATTHEWS  
 400 EAST I STREET, ERWIN, NC 28339  
 AHJ: HARNETT COUNTY (NC)  
 UTILITY: DUKE ENERGY (NC)  
 METER: 332316907  
 PHONE: (910) 890-1153  
 EMAIL: BILLYSM13@GMAIL.COM  
 FINANCE: OTHER

SYSTEM:  
 SYSTEM SIZE (DC): 17 X 410 = 6.970 kW  
 SYSTEM SIZE (AC): 5.000 kW @ 240V  
 MODULES: 17 X REC SOLAR: REC410AA PURE-R  
 OPTIMIZERS: 17 X SOLAREEDGE P505  
 INVERTER: SOLAREEDGE SE5000H-USRGM [S11]

REVISIONS		
NO.	REVISED BY	DATE
-	-	-
-	-	-
-	-	-

**freedom**  
 FOREVER

FREEDOM FOREVER LLC  
 415 INDUSTRIAL CT., GREER, SC 29651  
 Tel: (800) 385-1075

GREG ALBRIGHT

CONTRACTOR LICENSE:  
 ELECTRICAL CONTRACTOR U.34043

NOTE:  
 CONDUIT AND CONDUCTORS SPECIFICATIONS ARE BASED ON MINIMUM CODE REQUIREMENTS AND ARE NOT MEANT TO LIMIT UP-SIZING AS REQUIRED BY FIELD CONDITIONS

THREE LINE DIAGRAM			
JOB NO: 334165	DATE: 6/5/2023	DESIGNED BY: A.K.	SHEET: PV-4







**WARNING:**  
POWER SOURCE OUTPUT  
CONNECTION  
DO NOT RELOCATE THIS  
OVERCURRENT DEVICE.

705.12(B)(2)(3)(b)

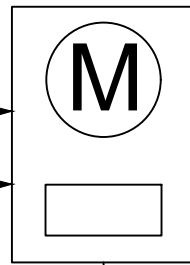

**"WARNING"**  
DUAL POWER SOURCES  
SECOND SOURCE IS PHOTOVOLTAIC SYSTEM  
RATED AC OUTPUT CURRENT - 21.00 AMPS  
AC NORMAL OPERATING VOLTAGE - 240 VOLTS

690.54

**NOTES:**

- NEC ARTICLES 690 AND 705 AND IRC SECTION R324 MARKINGS SHOWN HEREON.
- ALL MARKING SHALL CONSIST OF THE FOLLOWING:
  - UV RESISTANT SIGN MATERIAL WITH ENGRAVED OR MACHINE PRINTED LETTERS OR ELECTRO-PLATING.
  - RED BACKGROUND COLOR WHITE TEXT AND LINE WORK.
  - ARIAL FONT.
- ALL SIGNS SHALL BE SIZED APPROPRIATELY AND PLACED IN THE LOCATIONS SPECIFIED. SIGNAGE CANNOT BE HAND-WRITTEN.
- SIGNS SHALL BE ATTACHED TO THE SERVICE EQUIPMENT WITH POP-RIVETS OR SCREWS

**SOLAR PV SYSTEM EQUIPPED  
WITH RAPID SHUTDOWN**

TURN RAPID  
SHUTDOWN SWITCH TO  
THE "OFF" POSITION TO  
SHUT DOWN PV SYSTEM  
AND REDUCE SHOCK  
HAZARD IN THE ARRAY

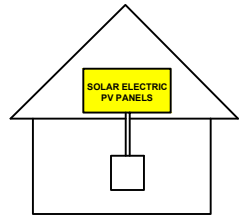

690.56(C)(1)(A)

PV METER

PM

AC

**PV SYSTEM AC DISCONNECT**  
RATED AC OUTPUT CURRENT - 21.00 AMPS  
AC NORMAL OPERATING VOLTAGE - 240 VOLTS

690.15, 690.54

**RAPID SHUTDOWN SWITCH FOR  
SOLAR PV SYSTEM**

690.56(C)(3)

INVERTER

MAXIMUM VOLTAGE  V  
MAXIMUM CIRCUIT CURRENT  A  
MAX DC-DC CONVERTER  
OUTPUT CURRENT  A

**"WARNING"**  
ELECTRICAL SHOCK HAZARD.  
TERMINALS ON BOTH LINE AND LOAD SIDES  
MAY BE ENERGIZED IN THE OPEN POSITION.

690.13 (B)

**PV SYSTEM DC DISCONNECT**  
MAXIMUM VOLTAGE: 480V  
MAXIMUM CIRCUIT CURRENT: 13.5A  
MAX RATED OUTPUT CURRENT OF  
THE CONTROLLER OR DC-TO-DC  
CONVERTER: 15A

690.53

**ARRAY**

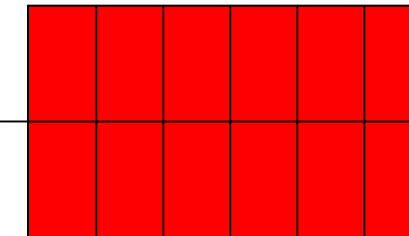

NEC 690.31(G)(3) & (4)

**"WARNING"**  
PHOTOVOLTAIC POWER SOURCE

EVERY 10' ON CONDUIT AND ENCLOSURES

CLIENT:  
WILLIE MATTHEWS  
400 EAST I STREET, ERWIN, NC 28339  
AHJ: HARNETT COUNTY (NC)  
UTILITY: DUKE ENERGY (NC)  
METER: 332316907  
PHONE: (910) 890-1153  
EMAIL: BILLYSM13@GMAIL.COM  
FINANCE: OTHER

SYSTEM:  
SYSTEM SIZE (DC): 17 X 410 = 6.970 kW  
SYSTEM SIZE (AC): 5.000 kW @ 240V  
MODULES: 17 X REC SOLAR: REC410AA  
PURE-R  
OPTIMIZERS: 17 X SOLAREEDGE P505  
INVERTER: SOLAREEDGE SE5000H-USRGM [S11]

REVISIONS		
NO.	REVISED BY	DATE
-	-	-
-	-	-
-	-	-



FREEDOM FOREVER LLC  
415 INDUSTRIAL CT., GREER, SC 29651  
Tel: (800) 385-1075

GREG ALBRIGHT

CONTRACTOR LICENSE:  
ELECTRICAL CONTRACTOR U.34043

LABELS

JOB NO:	DATE:	DESIGNED BY:	SHEET:
334165	6/5/2023	A.K.	PV-7

1

# CAUTION:

POWER TO THIS BUILDING IS ALSO SUPPLIED FROM THE FOLLOWING SOURCES WITH DISCONNECTS AS SHOWN

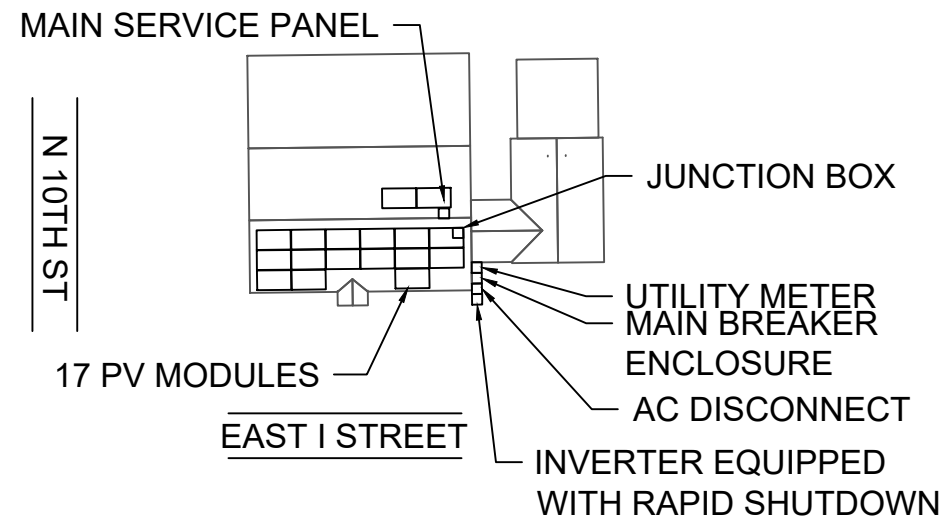

**WARNING**  
**TURN OFF PHOTOVOLTAIC AC DISCONNECT**  
**PRIOR TO WORKING INSIDE PANEL**



**CLIENT:**  
 WILLIE MATTHEWS  
 400 EAST I STREET, ERWIN, NC 28339  
 AHJ: HARNETT COUNTY (NC)  
 UTILITY: DUKE ENERGY (NC)  
 METER: 332316907  
 PHONE: (910) 890-1153  
 EMAIL: BILLYSM13@GMAIL.COM  
 FINANCE: OTHER

**SYSTEM:**  
 SYSTEM SIZE (DC): 17 X 410 = 6.970 kW  
 SYSTEM SIZE (AC): 5.000 kW @ 240V  
 MODULES: 17 X REC SOLAR: REC410AA  
 PURE-R  
 OPTIMIZERS: 17 X SOLAREEDGE P505  
 INVERTER: SOLAREEDGE SE5000H-USRGM [S1]

REVISIONS		
NO.	REVISED BY	DATE
-	-	-
-	-	-
-	-	-



**FREEDOM FOREVER LLC**  
 415 INDUSTRIAL CT., GREER, SC 29651  
 Tel: (800) 385-1075

**GREG ALBRIGHT**

**CONTRACTOR LICENSE:**  
 ELECTRICAL CONTRACTOR U.34043

**SITE PLACARD**

JOB NO:	DATE:	DESIGNED BY:	SHEET:
334165	6/5/2023	A.K.	PV-7A

**NOTES:**

1. NEC ARTICLES 690 AND 705 AND IRC SECTION R324 MARKINGS SHOWN HEREON.
2. ALL MARKING SHALL CONSIST OF THE FOLLOWING:
  - A. UV RESISTANT SIGN MATERIAL WITH ENGRAVED OR MACHINE PRINTED LETTERS OR ELECTRO-PLATING.
  - B. RED BACKGROUND COLOR WHITE TEXT AND LINE WORK.
  - C. AERIAL FONT.
3. ALL SIGNS SHALL BE SIZED APPROPRIATELY AND PLACED IN THE LOCATIONS SPECIFIED. SIGNAGE CANNOT BE HAND-WRITTEN.
4. SIGNS SHALL BE ATTACHED TO THE SERVICE EQUIPMENT WITH POP-RIVETS OR SCREWS.

# SOLAREEDGE OPTIMIZER CHART

1-10    11-20    21-30    31-40    41-50    51-60

1  
2  
3  
4  
5  
6  
7  
8  
9  
10

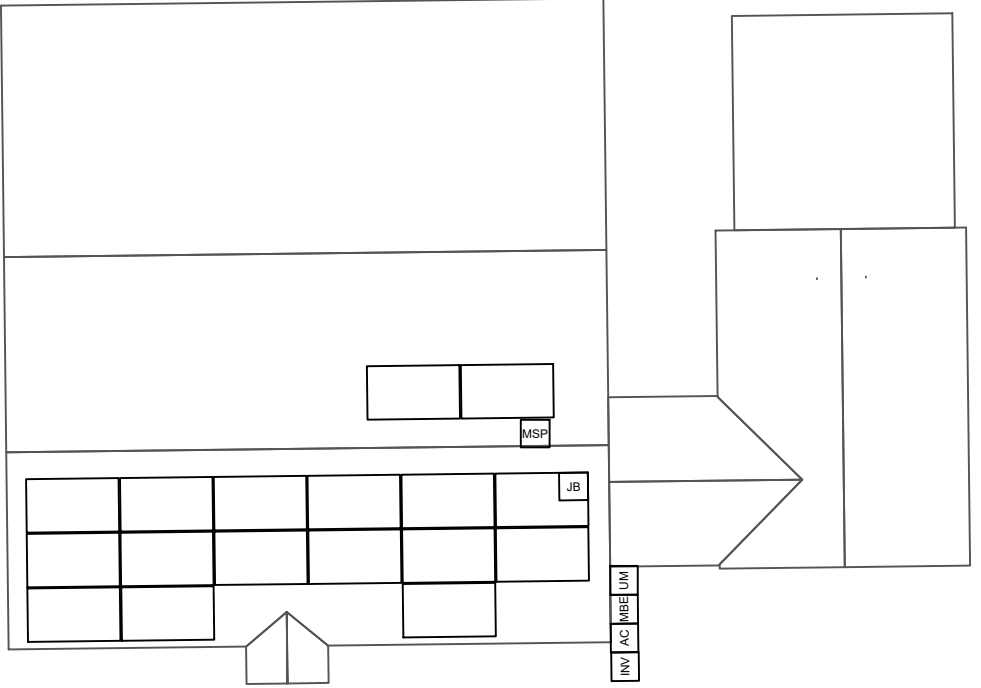
**CLIENT:**  
 WILLIE MATTHEWS  
 400 EAST I STREET, ERWIN, NC 28339  
 AHJ: HARNETT COUNTY (NC)  
 UTILITY: DUKE ENERGY (NC)  
 METER: 332316907  
 PHONE: (910) 890-1153  
 EMAIL: BILLYSM13@GMAIL.COM  
 FINANCE: OTHER

**SYSTEM:**  
 SYSTEM SIZE (DC): 17 X 410 = 6.970 kW  
 SYSTEM SIZE (AC): 5.000 kW @ 240V  
 MODULES: 17 X REC SOLAR: REC410AA  
 PURE-R  
 OPTIMIZERS: 17 X SOLAREEDGE P505  
 INVERTER: SOLAREEDGE SE5000H-USRGM [S1]

REVISIONS		
NO.	REVISED BY	DATE
-	-	-
-	-	-
-	-	-



**FREEDOM FOREVER LLC**  
 415 INDUSTRIAL CT., GREER, SC 29651  
 Tel: (800) 385-1075

**GREG ALBRIGHT**

**CONTRACTOR LICENSE:**  
 ELECTRICAL CONTRACTOR U.34043

OPTIMIZER CHART			
JOB NO:	DATE:	DESIGNED BY:	SHEET:
334165	6/5/2023	A.K.	PV-8

# SAFETY PLAN

# MARK UP KEY

### INSTRUCTIONS:

- USE SYMBOLS IN KEY TO MARK UP THIS SHEET.
- SAFETY PLAN MUST BE MARKED BEFORE JOB STARTS AS PART OF THE PRE-PLAN
- DOCUMENT ALL ADDITIONAL HAZARDS ON THIS PAGE & MAKE NOTES ON THE JHA SHEET

### INCIDENT REPORTING:

INJURIES - CALL INJURY HOTLINE

**(855) 400-7233**

*\*If injury is life threatening, call 911 first THEN the Injury Hotline*

NON-INJURIES - USE MOBILE INCIDENT REPORTING

(Auto, Property Damage, Near Miss)



### NEAREST OCCUPATIONAL/INDUSTRIAL CLINIC:

NAME: \_\_\_\_\_

ADDRESS: \_\_\_\_\_

### NEAREST HOSPITAL:

NAME: \_\_\_\_\_

ADDRESS: \_\_\_\_\_

### SAFETY COACH CONTACT INFORMATION:

NAME: \_\_\_\_\_

PHONE NUMBER: \_\_\_\_\_

ALL EMPLOYEES ON SITE SHALL BE MADE AWARE OF THE SAFETY PLAN AND SIGN INDICATING THAT THEY ARE AWARE OF THE HAZARDS ON-SITE AND THE PLAN FOR WORKING SAFELY.

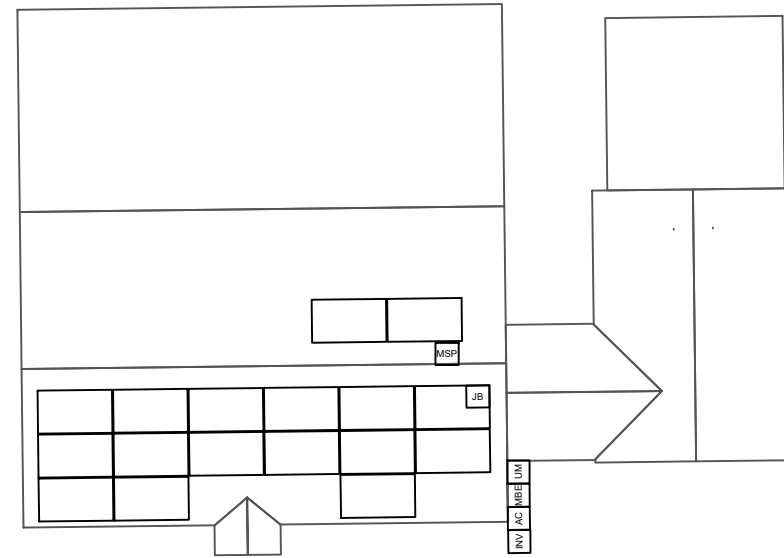

- P PERMANENT ANCHOR
- T TEMPORARY ANCHOR
- IL INSTALLER LADDER
- B JUNCTION / COMBINER BOX
- S STUB-OUT
- ☒ SKYLIGHT
- NO LADDER ACCESS (STEEP GRADE OR GROUND LEVEL OBSTRUCTIONS)
- RESTRICTED ACCESS
- CONDUIT
- GAS GAS SHUT OFF
- H<sub>2</sub>O WATER SHUT OFF
- 7 SERVICE DROP
- Z POWER LINES

**CLIENT:**  
 WILLIE MATTHEWS  
 400 EAST I STREET, ERWIN, NC 28339  
 AHJ: HARNETT COUNTY (NC)  
 UTILITY: DUKE ENERGY (NC)  
 METER: 332316907  
 PHONE: (910) 890-1153  
 EMAIL: BILLYSM13@GMAIL.COM  
 FINANCE: OTHER

**SYSTEM:**  
 SYSTEM SIZE (DC): 17 X 410 = 6.970 kW  
 SYSTEM SIZE (AC): 5.000 kW @ 240V  
 MODULES: 17 X REC SOLAR: REC410AA PURE-R  
 OPTIMIZERS: 17 X SOLAREEDGE P505  
 INVERTER: SOLAREEDGE SE5000H-USRGM [S11]

# BREAK AND WATER LOG

THIS LOG IS TO BE FILLED OUT ANY TIME THE TEMP EXCEEDS 90 DEGREES. THE CREW LEAD AND ROOF LEAD ARE RESPONSIBLE FOR ENSURING THIS IS COMPLETED AND UPLOADED AT THE END OF EVERYDAY WHEN TEMPS EXCEED 90 DEGREES

REVISIONS		
NO.	REVISED BY	DATE
-	-	-
-	-	-
-	-	-

NAME	SIGNATURE

DATE: \_\_\_\_\_ TIME: \_\_\_\_\_

NAME	0800HRS	0900HRS	1000HRS	1100HRS	1200HRS	1300HRS	1400HRS	1500HRS	1600HRS

**freedom**  
FOREVER

FREEDOM FOREVER LLC  
 415 INDUSTRIAL CT., GREER, SC 29651  
 Tel: (800) 385-1075

GREG ALBRIGHT

CONTRACTOR LICENSE:  
ELECTRICAL CONTRACTOR U.34043

SAFETY PLAN			
JOB NO:	DATE:	DESIGNED BY:	SHEET:
334165	6/5/2023	A.K.	PV-9

# JOB HAZARD ANALYSIS

Crew leader to fill out all sections below, hold a pre-job safety meeting with all personnel, and upload this completed document and the Safety Plan to Site Capture

### Ladder Access

- Ladders must be inspected before each use.
- Extension ladders must be set up on a firm and level surface at a 4-to-1 rise to run angle (or 75 degrees) and the top must be secured to the structure. Extension style ladders placed on uneven, loose or slippery surfaces must additionally have the base firmly anchored or lashed so the base will not slip out.
- Extension ladders must be used with walk-through devices or the ladder must extend 36" above the stepping off point.
- A-frame ladders must only be climbed with the ladder spreader bars locked in the open position; A-frame ladders shall not be climbed while in the closed position (ex, closed and used while leaned against a structure).

Additional notes:

### Mobile Equipment

- Only Qualified operators will operate equipment; operators must maintain a certification on their person for the equipment being operated.
- Type(s) of mobile equipment (Type/Make/Model):
- Qualified operator(s):

### Material Handling and Storage

- Materials will be staged/stored in a way that does not present a hazard to client, personnel or public. Materials stored on the roof will be physically protect from failing or sliding off.

### Fall Protection

- A site-specific plan for fall prevention and protection is required prior to starting work and must remain onsite at all times until work is complete; a fall rescue plan must be outlined and discussed among the crew prior to work start.
- First-person-Up (FPU) must install their anchor and connect before any other task, including installing other anchors. The Last-Person-Down (LPD) must be the only person on a roof uninstalling fall protection.

FPCP (name and title):

FPU and LPD (name and title):

### Electrical Safety

- The Electrical Qualified Person (EQP) is required onsite to perform electrical work.
- All electrical work will be performed with equipment in an electrically safe condition (de-energized) unless approval has been granted prior to work.
- Service drops and overhead electrical hazards will be identified and protected from contact, as necessary.

EQP (name and title):

### Public Protection

- The safety of the Client and Public must be maintained at all times.
- The Client and the Public shall be prevented from entering the work zone through the use of barriers and/or signage, as required.
- Company, Client and Public property shall be protected from falling objects.
- Pets (including dogs) shall be secured by their owners prior to work start.
- The Client should not leave pets, family members, or others in charge or care of Employees, Contractors, or Temporary Workers.

Crew leader responsible for communication with the client:

Client and public is excluded from work area by barricades (N/A, Yes, No):

### Training and Pre-Job Safety Briefing

- All employees onsite shall be made aware of the specific hazards of this project and review this HJA during a pre-job briefing, and their signature indicates awareness of site conditions and the plan to eliminate any hazards identified prior to and during the project.

Crew leader (name/title):

Crew member (name/title):

Crew member (name/title):

Crew member (name/title):

Crew member (name/title):

Crew member (name/title):

### Airborne Contaminants:

- Asbestos-containing (Transite) piping (ACP) - Do not disturb (move, drill, cut fracture, etc.)
- Asbestos-containing thermal insulation (ACI) and Asbestos-containing duct wrapping (ACW) - do not disturb, no attic or crawlspace access is allowed if work to be performed could cause exposure to personnel, client or public.

If yes, list specific tasks and protection in place:

### Weather and Environment

- The site supervisor shall forecast the weather conditions at the job site, prior to crew arrival, in order to mitigate any hazards associated with inclement weather (heat, cold, wind, rain, etc.)
- The site supervisor will utilized a portable wind meter (anemometer) to verify actual onsite wind conditions, by checking at the ground and on any elevated work surface (ex, rooftop) prior to work start, at midday and prior to solar panel staging on a roof.
- Elevated work involving the moving or maneuvering of solar panels shall cease at 25mph (sustained wind) until wind subsides.

Forecasted weather maximum temp (degrees f):

### Heat Related Illness Prevention

- Employees shall have access to potable drinking water that is fresh, pure, and suitably cool. The water shall be located as close as practicable to the areas where employees are working. Water shall be supplied in sufficient quantity at the beginning of the work shift to provide at least one quart per employee per hour for drinking for the entire shift. Employees may begin the shift with smaller quantities of water if they identify the location and have effective means for replenishment during the shift to allow employees to drink on quart or more per hour. The frequent drinking of water shall be encouraged.
- Shade shall be present when temperature exceeds 80 degrees Fahrenheit. When the outdoor temperature in the work exceeds 80 degrees Fahrenheit, employees shall have and maintain one or more areas with shade at all times.
- New employees must be acclimatized. New employees will be monitored by their Crew Leader (site supervisor) for the first two (2) weeks of employment or longer when necessary.
- Employees will be allowed and encouraged to implement scheduled breaks during each shift. Employees must take cool-down breaks in the shade any time they feel the need to do so to protect them from overheating. Supervisors are REQUIRED to allow employees any break period they need during high heat conditions.
- Cool Vests are encouraged for all employees at all times during periods of high heat.
- Identify the location of the closet Occupational/Industrial Clinic or Hospital in case a crew member becomes ill.

What is the specific plan to provide and replenish sufficient water for all employees on site?

If offsite replenish is necessary, where will you go to replenish water (location/address):

Who will replenish the drinking water (name):

### Restroom facilities

- Employees shall have access to restroom facilities with hand-washing stations. Use of onsite restroom is at the client's discretion (location is annotated below). If client does not give permission, location of suitable restroom facilities with hand-washing stations offsite will be provided. The onsite supervisor will identify location and make arrangements to ensure all employees have access at any point.

Restroom facilities will be (circle one): Onsite - Offsite

If Offsite, add location name and address:

### Incident Reporting Procedure

Contact your Site Supervisor  
Name:

Phone:

Contact your Manager  
Name:

Phone:

Contact your Site Supervisor  
Name:

Phone:

With: Your full name, phone number, office location, brief description of what happen and when.

### NOTE ADDITIONAL HAZARDS NOT ADDRESSED ABOVE

(add as many as necessary by using additional sheets)

Define the Hazard:	Method/steps to prevent incident:
Define the Hazard:	Method/steps to prevent incident:
Define the Hazard:	Method/steps to prevent incident:
Define the Hazard:	Method/steps to prevent incident:

**CLIENT:**  
WILLIE MATTHEWS  
400 EAST I STREET, ERWIN, NC 28339  
AHJ: HARNETT COUNTY (NC)  
UTILITY: DUKE ENERGY (NC)  
METER: 332316907  
PHONE: (910) 890-1153  
EMAIL: BILLYSM13@GMAIL.COM  
FINANCE: OTHER

**SYSTEM:**  
SYSTEM SIZE (DC): 17 X 410 = 6.970 kW  
SYSTEM SIZE (AC): 5.000 kW @ 240V  
MODULES: 17 X REC SOLAR: REC410AA  
PURE-R  
OPTIMIZERS: 17 X SOLAREEDGE P505  
INVERTER: SOLAREEDGE SE5000H-USRGM [S11]

REVISIONS		
NO.	REVISED BY	DATE
-	-	-
-	-	-
-	-	-



**FREEDOM FOREVER LLC**  
415 INDUSTRIAL CT., GREER, SC 29651  
Tel: (800) 385-1075

**GREG ALBRIGHT**

*Greg Albright*

**CONTRACTOR LICENSE:**  
ELECTRICAL CONTRACTOR U.34043

### SAFETY PLAN

JOB NO: 334165	DATE: 6/5/2023	DESIGNED BY: A.K.	SHEET: PV-10
-------------------	-------------------	----------------------	-----------------



# REC ALPHA PURE-R SERIES

## PRODUCT SPECIFICATIONS

COMPACT PANEL SIZE

9 A PANEL CURRENT  
COMPATIBLE WITH MLPE

430 WP  
223 W/m<sup>2</sup>



ELIGIBLE

  
LEAD FREE  
ROHS COMPLIANT

EXPERIENCE  
  
PERFORMANCE

# REC ALPHA PURE-R SERIES

## PRODUCT SPECIFICATIONS

### GENERAL DATA

Cell type:	80 half-cut REC heterojunction cells with lead-free, gapless technology
Glass:	3.2 mm solar glass with anti-reflective surface treatment in accordance with EN 12150
Backsheet:	Highly resistant polymer (black)
Frame:	Anodized aluminum (black)
Junction box:	4-part, 4 bypass diodes, lead-free IP68 rated, in accordance with IEC 62790
Connectors:	Stäubli MC4 PV-KBT4/KST4 (4 mm <sup>2</sup> ) in accordance with IEC 62852, IP68 only when connected
Cable:	4 mm <sup>2</sup> solar cable, 1.7 + 1.7 m in accordance with EN 50618
Dimensions:	1730 x 1118 x 30 mm (1.93 m <sup>2</sup> )
Weight:	21.5 kg
Origin:	Made in Singapore

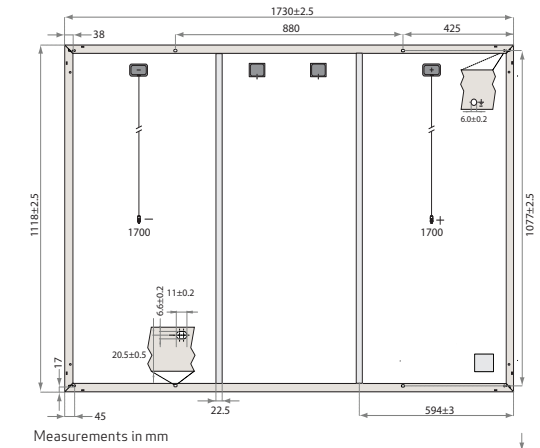

### ELECTRICAL DATA

	Product Code*: RECxxxAA Pure-R			
Power Output - P <sub>MAX</sub> (Wp)	400	410	420	430
Watt Class Sorting - (W)	0/+10	0/+10	0/+10	0/+10
Nominal Power Voltage - V <sub>MPP</sub> (V)	48.8	49.4	50.0	50.5
Nominal Power Current - I <sub>MPP</sub> (A)	8.20	8.30	8.40	8.52
Open Circuit Voltage - V <sub>OC</sub> (V)	58.9	59.2	59.4	59.7
Short Circuit Current - I <sub>SC</sub> (A)	8.80	8.84	8.88	8.91
Power Density (W/m <sup>2</sup> )	207	212	218	223
Panel Efficiency (%)	20.7	21.2	21.8	22.3
Power Output - P <sub>MAX</sub> (Wp)	305	312	320	327
Nominal Power Voltage - V <sub>MPP</sub> (V)	46.0	46.6	47.1	47.6
Nominal Power Current - I <sub>MPP</sub> (A)	6.64	6.70	6.80	6.88
Open Circuit Voltage - V <sub>OC</sub> (V)	55.5	55.8	56.0	56.3
Short Circuit Current - I <sub>SC</sub> (A)	7.11	7.16	7.20	7.24

Values at standard test conditions (STC: air mass AM 1.5, irradiance 1000 W/m<sup>2</sup>, temperature 25°C), based on a production spread with a tolerance of P<sub>MAX</sub>, V<sub>OC</sub> & I<sub>SC</sub> ±3% within one watt class. Nominal module operating temperature (NMOT: air mass AM 1.5, irradiance 800 W/m<sup>2</sup>, temperature 20°C, windspeed 1 m/s). \* Where xxx indicates the nominal power class (P<sub>MAX</sub>) at STC above.

### MAXIMUM RATINGS

Operational temperature:	-40 ... +85°C
System voltage:	1000 V
Test load (front):	+7000 Pa (713 kg/m <sup>2</sup> )*
Test load (rear):	-4000 Pa (407 kg/m <sup>2</sup> )*
Series fuse rating:	25 A
Reverse current:	25 A

\* See installation manual for mounting instructions.  
Design load = Test load / 1.5 (safety factor)

### WARRANTY

	Standard	REC ProTrust	
Installed by an REC Certified Solar Professional	No	Yes	Yes
System Size	All	≤25 kW 25-500 kW	
Product Warranty (yrs)	20	25	25
Power Warranty (yrs)	25	25	25
Labor Warranty (yrs)	0	25	10
Power in Year 1	98%	98%	98%
Annual Degradation	0.25%	0.25%	0.25%
Power in Year 25	92%	92%	92%

The REC ProTrust Warranty is only available on panels purchased through an REC Certified Solar Professional installer. Warranty conditions apply. See [www.recgroup.com](http://www.recgroup.com) for more details.

Available from:

Founded in 1996, REC Group is an international pioneering solar energy company dedicated to empowering consumers with clean, affordable solar power. As Solar's Most Trusted, REC is committed to high quality, innovation, and a low carbon footprint in the solar materials and solar panels it manufactures. Headquartered in Norway with operational headquarters in Singapore, REC also has regional hubs in North America, Europe, and Asia-Pacific.

### CERTIFICATIONS

IEC 61215:2016, IEC 61730:2016, UL 61730	
IEC 62804	PID
IEC 61701	Salt Mist
IEC 62716	Ammonia Resistance
ISO 11925-2	Ignitability (EN 13501-1 Class E)
IEC 62782	Dynamic Mechanical Load
IEC 61215-2:2016	Hailstone (35mm)
IEC 62321	Lead-free acc. to RoHS EU 863/2015
IEC 61730-2:2016	Fire Class C (as per UL 790)
ISO 14001, ISO 9001, IEC 45001, IEC 62941	



### TEMPERATURE RATINGS\*

Nominal Module Operating Temperature:	44°C (±2°C)
Temperature coefficient of P <sub>MAX</sub> :	-0.24 %/°C
Temperature coefficient of V <sub>OC</sub> :	-0.24 %/°C
Temperature coefficient of I <sub>SC</sub> :	0.04 %/°C

\*The temperature coefficients stated are linear values

### DELIVERY INFORMATION

Panels per pallet:	33
Panels per 40 ft GP/high cube container:	858 (26 pallets)
Panels per 13.6 m truck:	924 (28 pallets)

### LOW LIGHT BEHAVIOUR

Typical low irradiance performance of module at STC:

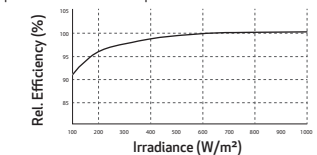



# Power Optimizer

For North America

P320 / P340 / P370 / P400 / P401 / P405 / P485 / P505



POWER OPTIMIZER

## PV power optimization at the module-level

- Specifically designed to work with SolarEdge inverters
- Up to 25% more energy
- Superior efficiency (99.5%)
- Mitigates all types of module mismatch losses, from manufacturing tolerance to partial shading
- Flexible system design for maximum space utilization
- Fast installation with a single bolt
- Next generation maintenance with module-level monitoring
- Meets NEC requirements for arc fault protection (AFCI) and Photovoltaic Rapid Shutdown System (PVRSS)
- Module-level voltage shutdown for installer and firefighter safety

solaredge.com



## / Power Optimizer

For North America

P320 / P340 / P370 / P400 / P401 / P405 / P485 / P505

Optimizer model (typical module compatibility)	P320 (for 60-cell modules)	P340 (for high-power 60-cell modules)	P370 (for higher-power 60 and 72-cell modules)	P400 (for 72 & 96-cell modules)	P401 (for high power 60 and 72 cell modules)	P405 (for high-voltage modules)	P485 (for high-voltage modules)	P505 (for higher current modules)		
<b>INPUT</b>										
Rated Input DC Power <sup>(1)</sup>	320	350	370	400	405	485	505	W		
Absolute Maximum Input Voltage (Voc at lowest temperature)	48		60	80	60	125 <sup>(2)</sup>	83 <sup>(2)</sup>	Vdc		
MPPT Operating Range	8 - 48		8 - 60	8 - 80	8-60	12.5 - 105		12.5 - 83	Vdc	
Maximum Short Circuit Current (Isc)	11	11.02	11	10.1	11.75	11	14	Adc		
Maximum DC Input Current	13.75			12.5	14.65	12.5	17.5	Adc		
Maximum Efficiency	99.5									
Weighted Efficiency	98.8							98.6	%	
Overvoltage Category	II									
<b>OUTPUT DURING OPERATION (POWER OPTIMIZER CONNECTED TO OPERATING SOLAREEDGE INVERTER)</b>										
Maximum Output Current	15								Adc	
Maximum Output Voltage	60					85				Vdc
<b>OUTPUT DURING STANDBY (POWER OPTIMIZER DISCONNECTED FROM SOLAREEDGE INVERTER OR SOLAREEDGE INVERTER OFF)</b>										
Safety Output Voltage per Power Optimizer	1 ± 0.1								Vdc	
<b>STANDARD COMPLIANCE</b>										
EMC	FCC Part15 Class B, IEC61000-6-2, IEC61000-6-3									
Safety	IEC62109-1 (class II safety), UL1741									
Material	UL94 V-0, UV Resistant									
RoHS	Yes									
<b>INSTALLATION SPECIFICATIONS</b>										
Maximum Allowed System Voltage	1000									Vdc
Compatible inverters	All SolarEdge Single Phase and Three Phase inverters									
Dimensions (W x L x H)	129 x 153 x 27.5 / 5.1 x 6 x 1.1		129 x 153 x 33.5 / 5.1 x 6 x 1.3	129 x 153 x 29.5 / 5.1 x 6 x 1.16	129 x 159 x 49.5 / 5.1 x 6.3 x 1.9		129 x 162 x 59 / 5.1 x 6.4 x 2.3		mm / in	
Weight (including cables)	630 / 1.4		750 / 1.7	655 / 1.5	845 / 1.9		1064 / 2.3		gr / lb	
Input Connector	MC4 <sup>(3)</sup>						Single or dual MC4 <sup>(3)(4)</sup>	MC4 <sup>(3)</sup>		
Input Wire Length	0.16 / 0.52				0.16 or 0.9 / 0.52 or 2.95 <sup>(5)</sup>	0.16 / 0.52			m / ft	
Output Wire Type / Connector	Double Insulated / MC4									
Output Wire Length	0.9 / 2.95			1.2 / 3.9						m / ft
Operating Temperature Range <sup>(6)</sup>	-40 to +85 / -40 to +185									°C / °F
Protection Rating	IP68 / Type 6P									
Relative Humidity	0 - 100									%

(1) Rated power of the module at STC will not exceed the optimizer "Rated Input DC Power". Modules with up to +5% power tolerance are allowed  
 (2) NEC 2017 requires max input voltage be not more than 80V  
 (3) For other connector types please contact SolarEdge  
 (4) For dual version for parallel connection of two modules use P485-4NMDMRM. In the case of an odd number of PV modules in one string, installing one P485 dual version power optimizer connected to one PV module. When connecting a single module seal the unused input connectors with the supplied pair of seals  
 (5) Longer inputs wire length are available for use. For 0.9m input wire length order P401-xxxLxxx  
 (6) For ambient temperature above +85°C / +185°F power de-rating is applied. Refer to Power Optimizers Temperature De-Rating Technical Note for more details

PV System Design Using a SolarEdge inverter <sup>(7)(8)</sup>	Single Phase HD-Wave	Single phase	Three Phase for 208V grid	Three Phase for 277/480V grid	
Minimum String Length (Power Optimizers)	P320, P340, P370, P400, P401 P405, P485, P505	8	10	18	
Maximum String Length (Power Optimizers)		6	8	14	
		25	25	50 <sup>(9)</sup>	
Maximum Power per String		5700 (6000 with SE7600-US - SE11400-US)	5250	6000 <sup>(10)</sup>	12750 <sup>(11)</sup> W
Parallel Strings of Different Lengths or Orientations	Yes				

(7) For detailed string sizing information refer to: [http://www.solaredge.com/sites/default/files/string\\_sizing\\_na.pdf](http://www.solaredge.com/sites/default/files/string_sizing_na.pdf)  
 (8) It is not allowed to mix P405/P485/P505 with P320/P340/P370/P400/P401 in one string  
 (9) A string with more than 30 optimizers does not meet NEC rapid shutdown requirements; safety voltage will be above the 30V requirement  
 (10) For 208V grid: it is allowed to install up to 6,500W per string when the maximum power difference between each string is 1,000W  
 (11) For 277/480V grid: it is allowed to install up to 15,000W per string when the maximum power difference between each string is 2,000W



# Single Phase Inverter with HD-Wave Technology for North America

SE3000H-US / SE3800H-US / SE5000H-US / SE6000H-US / SE7600H-US / SE10000H-US / SE11400H-US



12-25  
YEAR  
WARRANTY

INVERTERS

## Optimized installation with HD-Wave technology

- Specifically designed to work with power optimizers
- Record-breaking 99% weighted efficiency
- Quick and easy inverter commissioning directly from a smartphone using the SolarEdge SetApp
- Fixed voltage inverter for longer strings
- Integrated arc fault protection and rapid shutdown for NEC 2014, NEC 2017 and NEC 2020 per article 690.11 and 690.12
- UL1741 SA certified, for CPUC Rule 21 grid compliance
- Small, lightweight, and easy to install both outdoors or indoors
- Built-in module-level monitoring
- Optional: Faster installations with built-in consumption metering (1% accuracy) and production revenue grade metering (0.5% accuracy, ANSI C12.20)

## Single Phase Inverter with HD-Wave Technology for North America

SE3000H-US / SE3800H-US / SE5000H-US / SE6000H-US / SE7600H-US / SE10000H-US / SE11400H-US

MODEL NUMBER	SE3000H-US	SE3800H-US	SE5000H-US	SE6000H-US	SE7600H-US	SE10000H-US	SE11400H-US	
APPLICABLE TO INVERTERS WITH PART NUMBER	SEXXXXH-XXXXXBXX4							
<b>OUTPUT</b>								
Rated AC Power Output	3000	3800 @ 240V 3300 @ 208V	5000	6000 @ 240V 5000 @ 208V	7600	10000	11400 @ 240V 10000 @ 208V	VA
Maximum AC Power Output	3000	3800 @ 240V 3300 @ 208V	5000	6000 @ 240V 5000 @ 208V	7600	10000	11400 @ 240V 10000 @ 208V	VA
AC Output Voltage Min.-Nom.-Max. (211 - 240 - 264)	✓	✓	✓	✓	✓	✓	✓	Vac
AC Output Voltage Min.-Nom.-Max. (183 - 208 - 229)	-	✓	-	✓	-	-	✓	Vac
AC Frequency (Nominal)	59.3 - 60 - 60.5 <sup>(1)</sup>							Hz
Maximum Continuous Output Current @240V	12.5	16	21	25	32	42	47.5	A
Maximum Continuous Output Current @208V	-	16	-	24	-	-	48.5	A
Power Factor	1, Adjustable - 0.85 to 0.85							
GFDI Threshold	1							A
Utility Monitoring, Islanding Protection, Country Configurable Thresholds	Yes							
<b>INPUT</b>								
Maximum DC Power @240V	4650	5900	7750	9300	11800	15500	17650	W
Maximum DC Power @208V	-	5100	-	7750	-	-	15500	W
Transformer-less, Ungrounded	Yes							
Maximum Input Voltage	480							Vdc
Nominal DC Input Voltage	380							Vdc
Maximum Input Current @240V <sup>(2)</sup>	8.5	10.5	13.5	16.5	20	27	30.5	Adc
Maximum Input Current @208V <sup>(2)</sup>	-	9	-	13.5	-	-	27	Adc
Max. Input Short Circuit Current	45							Adc
Reverse-Polarity Protection	Yes							
Ground-Fault Isolation Detection	600k $\Omega$ Sensitivity							
Maximum Inverter Efficiency	99	99.2						%
CEC Weighted Efficiency	99						99 @ 240V 98.5 @ 208V	%
Nighttime Power Consumption	< 2.5							W

(1) For other regional settings please contact SolarEdge support

(2) A higher current source may be used; the inverter will limit its input current to the values stated

# / Single Phase Inverter with HD-Wave Technology

## for North America

SE3000H-US / SE3800H-US / SE5000H-US / SE6000H-US/  
SE7600H-US / SE10000H-US / SE11400H-US

MODEL NUMBER	SE3000H-US	SE3800H-US	SE5000H-US	SE6000H-US	SE7600H-US	SE10000H-US	SE11400H-US
<b>ADDITIONAL FEATURES</b>							
Supported Communication Interfaces	RS485, Ethernet, ZigBee (optional), Cellular (optional)						
Revenue Grade Metering, ANSI C12.20	Optional <sup>(3)</sup>						
Consumption metering							
Inverter Commissioning	With the SetApp mobile application using Built-in Wi-Fi Access Point for Local Connection						
Rapid Shutdown - NEC 2014, NEC 2017 and NEC 2020, 690.12	Automatic Rapid Shutdown upon AC Grid Disconnect						
<b>STANDARD COMPLIANCE</b>							
Safety	UL1741, UL1741 SA, UL1699B, CSA C22.2, Canadian AFCI according to T.I.L. M-07						
Grid Connection Standards	IEEE1547, Rule 21, Rule 14 (HI)						
Emissions	FCC Part 15 Class B						
<b>INSTALLATION SPECIFICATIONS</b>							
AC Output Conduit Size / AWG Range	1" Maximum / 14-6 AWG			1" Maximum / 14-4 AWG			
DC Input Conduit Size / # of Strings / AWG Range	1" Maximum / 1-2 strings / 14-6 AWG			1" Maximum / 1-3 strings / 14-6 AWG			
Dimensions with Safety Switch (HxWxD)	17.7 x 14.6 x 6.8 / 450 x 370 x 174			21.3 x 14.6 x 7.3 / 540 x 370 x 185			
Weight with Safety Switch	22 / 10	25.1 / 11.4	26.2 / 11.9	38.8 / 17.6			
Noise	< 25			< 50			
Cooling	Natural Convection						
Operating Temperature Range	-40 to +140 / -40 to +60 <sup>(4)</sup>						
Protection Rating	NEMA 4X (Inverter with Safety Switch)						

(3) Inverter with Revenue Grade Meter P/N: SExxxxH-US000BNC4; Inverter with Revenue Grade Production and Consumption Meter P/N: SExxxxH-US000BNI4. For consumption metering, current transformers should be ordered separately: SEACT0750-200NA-20 or SEACT0750-400NA-20. 20 units per box

(4) Full power up to at least 50°C / 122°F; for power de-rating information refer to: <https://www.solaredge.com/sites/default/files/se-temperature-derating-note-na.pdf>

## How to Enable Consumption Monitoring

By simply wiring current transformers through the inverter's existing AC conduits and connecting them to the service panel, homeowners will gain full insight into their household energy usage helping them to avoid high electricity bills

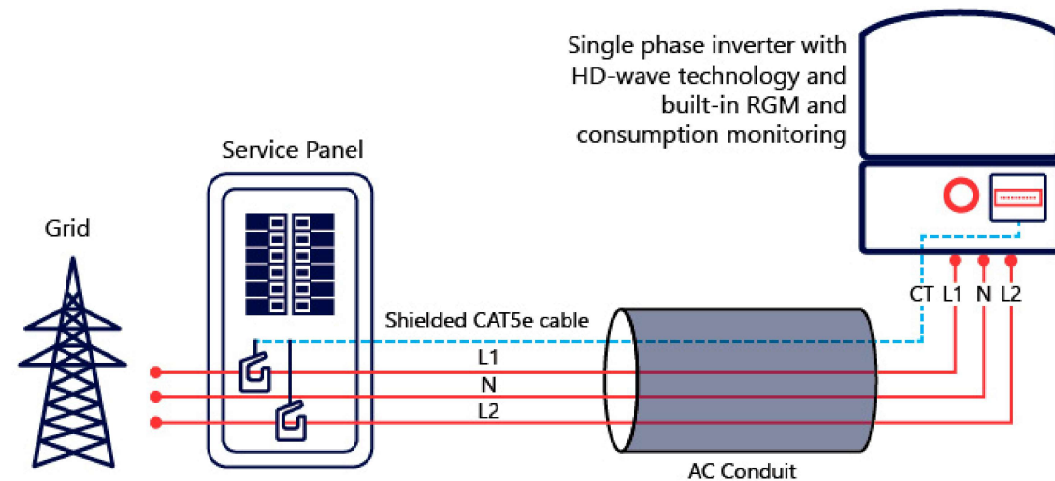

## Product specifications

# Eaton DG221NRB

Catalog Number: DG221NRB

Eaton General duty cartridge fuse safety switch, 30 A, NEMA 3R, Red painted galvanized steel, Class H fuses, Fusible with neutral, Two-pole, Three-wire, Category: general duty safety switch, 240 V

## General specifications

<b>Product Name</b>	<b>Catalog Number</b>
Eaton general duty cartridge fuse safety switch	DG221NRB
	<b>UPC</b>
	782113120317
<b>Product Length/Depth</b>	<b>Product Height</b>
6.88 in	10.81 in
<b>Product Width</b>	<b>Product Weight</b>
6.38 in	6 lb
<b>Warranty</b>	<b>Certifications</b>
Eaton Selling Policy 25-000, one (1) year from the date of installation of the Product or eighteen (18) months from the date of shipment of the Product, whichever occurs first.	UL Listed
	<b>Catalog Notes</b>
	Maximum hp ratings apply only when dual element fuses are used. 3-Phase hp rating shown is a grounded B phase rating, UL listed.



## Physical Attributes

**Enclosure**  
NEMA 3R

**Enclosure material**  
Painted galvanized steel

**Fuse configuration**  
Fusible with neutral

**Number Of Poles**  
Two-pole

**Number of wires**  
3

**Type**  
General duty, cartridge fused

## Performance Ratings

**Amperage Rating**  
30A

**Fuse class provision**  
Class H fuses

**Voltage rating**  
240V

## Miscellaneous

**Product Category**  
General duty safety switch

## Resources

**Catalogs**  
[Eaton's Volume 2—Commercial Distribution](#)

**Multimedia**  
[Double Up on Safety](#)  
[Switching Devices Flex Center](#)

**Specifications and datasheets**  
[Eaton Specification Sheet - DG221NRB](#)



Eaton Corporation plc  
Eaton House  
30 Pembroke Road  
Dublin 4, Ireland  
Eaton.com  
© 2023 Eaton. All Rights Reserved.

Eaton is a registered trademark.  
All other trademarks are property of their respective owners.



[Eaton.com/socialmedia](https://www.eaton.com/socialmedia)



## INSULATION-PIERCING TAP CONNECTORS CONECTORES DE DERIVACIÓN QUE PERFORAN EL AISLAMIENTO

### Installation Instructions:

**Warning**

Improperly installed electrical wiring can be dangerous and cause electrical fires. The connector chosen must be sized to the wires being used. Consult local building code before doing any electrical work. For assistance, refer to an instructional book or consult a qualified electrician.

**Warning**

Contact with electricity can cause serious injury or death. Use on insulated cable only. [RHH, RHW(-2), THHN, THHW, THW, THWN, USE, XHHW(-2)]. Consult factory for other insulation types). If the installation is to be made on an energized run, the tap conductor must be under no load and must not be grounded. Use electrically insulated gloves. De-energize the run cable if there are any questions of these conditions being met.

- Determine the direction for the tap conductor to exit and discard one end cap. **See figure 1.**
- Position the main (or feeder) side of the connector around the run cable and tighten the bolt finger tight. **See figure 2.** If required, loosen the bolt slightly to allow the connector to open completely. **DISASSEMBLY NOT RECOMMENDED.** The plastic "Turbo" spacer holds the connector open which eases installation and ensures proper connections.
- Cut the end of the tap cable squarely. **DO NOT STRIP CABLE INSULATION.**
- Insert the tap cable into the tap side of the connector until it is seated in the remaining end cap. **See figure 3.**
- Continue tightening the torque regulating bolt with a standard box or socket wrench until the torque regulating piece breaks away. If the connector has two (2) assembly bolts, alternately tighten until the hexagonal torque devices break away. **See figures 4a & 4b.** Note that the plastic "turbo" spacer on the side will also break. To make the installation even easier and to relieve torque from the cables, a second wrench can be used on the hexagonal piece on the bottom of the connector.

**DO NOT use gripping type pliers, pipe, open ended or adjustable wrenches** as these may damage the hexagonal torque regulating device. A torque wrench is not required.

**MAKE SURE ONLY THE TOP HEXAGONAL TORQUE DEVICE OF THE BOLT HEAD IS USED FOR ASSEMBLY. THE SECOND HEX PIECE [CLOSER TO THE BODY OF THE CONNECTOR] IS USED FOR DISASSEMBLY.**

Note: The torque regulating bolt ensures the correct torque is applied to the conductors without using a torque wrench. Important information such as run and tap ranges, voltage ratings and material/temperature ratings is marked on the connector.

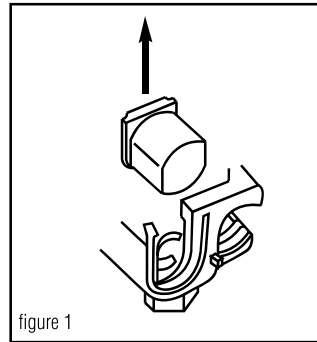

figure 1

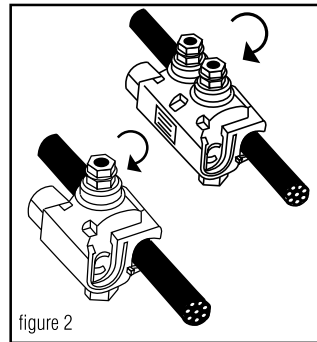

figure 2

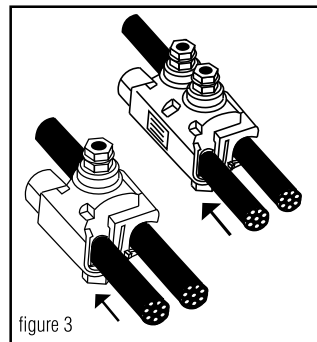

figure 3

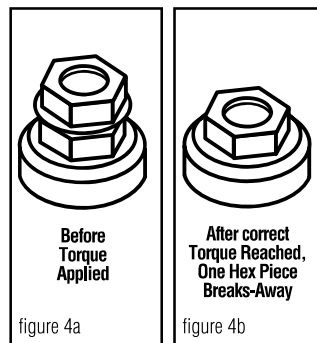

figure 4a

figure 4b

### Instalación Instrucciones:

**Advertencia**

Los cables eléctricos mal instalados pueden ser peligrosos y provocar incendios. El conector escogido debe ser de un tamaño adecuado para los cables que se utilicen. Consulte los códigos de construcción locales antes de efectuar trabajos eléctricos. Si necesita ayuda, consulte un libro de instrucciones o consulte con un electricista capacitado.

**Advertencia**

Use sólo en cable aislado. [RHH, RHW(-2), THHN, THHW, THW, THWN, USE, XHHW(-2)]. Consulte con la fábrica para obtener información sobre otros tipos de aislamiento). Si se va a hacer la instalación sobre un cable con corriente el conductor derivado debe estar libre de carga y no debe estar aterado. Use guantes con aislamiento eléctrico. Quite la corriente al cable del cual se hace la derivación si no se pueden cumplir estas condiciones. El contacto con electricidad puede producir lesiones graves o mortales.

- Determine la dirección en la que el conductor derivado saldrá y deseche la tapa terminal sobrante. **Vea la ilustración 1.**
- Coloque el lado principal (o de alimentación) del conector alrededor del cual se hace la derivación y apriete firmemente el dedo del perno. **Vea la ilustración 2.** Si hace falta, afloje el perno ligeramente para permitir que el conector se abra completamente. **NO ES RECOMENDABLE DESARMAR EL CONECTOR.** El espaciador "Turbo" de plástico mantiene al conector abierto, lo cual facilita la instalación y asegura que las conexiones se hagan correctamente.
- Corte el extremo del cable de derivación perpendicularmente a su eje. **NO PELE EL AISLAMIENTO DEL CABLE.**
- Inserte el cable de derivación en el lado de derivación del conector hasta que tope contra la tapa terminal que queda. **Vea la ilustración 3.**
- Continúe apretando este perno que regula la torsión con una llave estándar o de cubo hasta que la pieza que regula la torsión se parta y se separe. Si el conector tiene dos (2) pernos de ensamblaje, apriételes alternativamente hasta que el dispositivo de regulación de torció se parta. **Vea la ilustración 4a y 4b.** Observe que el espaciador "turbo" de plástico en el costado también se fracturará. Para hacer esta instalación aún más fácil y para aliviar la torsión de los cables, se puede usar una segunda llave sobre la pieza hexagonal al fondo del conector.

**NO USE alicates de presión, llaves de turbo, llaves comunes o ajustables** ya que éstas pueden dañar el dispositivo hexagonal que regula la torsión. No se requiere una llave de torsión.

**ASEGÚRESE QUE SE USE, PARA EL ENSAMBLADO, SÓLO EL DISPOSITIVO SUPERIOR DE REGULACIÓN DE TORSIÓN DE LA CABEZA DEL PERNO. LA SEGUNDA PIEZA HEXAGONAL (LA MÁS CERCANA AL CUERPO DEL CONECTOR) SE USA SÓLO PARA DESARMAR EL CONECTOR.**

Nota: El perno regulador de torsión garantiza la aplicación de la torsión correcta a los conductores sin usar una llave de torsión. La información importante de longitud de cable pelado y de toma, las clasificaciones de materiales y temperatura está marcada en el conector.

## B-TAP<sup>®</sup> INSULATION PIERCING TAP CONNECTORS TORQUE AND CURRENT RATINGS

(Solid and/or Stranded)

CATALOG#	MAIN	TAP	NOMINAL TORQUE	TAP CURRENT RATING (IN AMPS)*
BTC2/0-14	2/0-4	10-14+	80 IN. LBS.	40
BTC1/0-10	1/0-8	2-10++	80 IN. LBS.	130
BTC4/0-10	4/0-3	2-10+++	125 IN. LBS.	130
BTC4/0-6	4/0-2	1/0-6	160 IN. LBS.	170
BTC4/0-2	4/0-2	4/0-2	160 IN. LBS.	260
BTC250-6	250-4	4/0-6	160 IN. LBS.	260
BTC250-4	250-1	3/0-4	160 IN. LBS.	225
BTC250-2	250-1/0	4/0-2	160 IN. LBS.	260
BTC350-1/0	350-1/0	350-1/0	330 IN. LBS.	350
BTC500-4	500-2/0	4/0-4	330 IN. LBS.	260
BTC500-1/0	500-4/0	350-1/0	330 IN. LBS.	350
BTC500-14	750-3/0	10-14 ++++	80 IN. LBS.	40
BTC750-250	750-250	500-250	330 IN. LBS.	430

+10-14 Cu SOLID/STRANDED; 10-12 Al SOLID/STRANDED  
++2-10 Cu SOLID/STRANDED; 2-10 Al STRANDED  
+++2-10 Cu SOLID/STRANDED; 2-8 Al STRANDED  
++++10-14 Cu SOLID/STRANDED; 10-12 Al STRANDED

Full line is 600V dual-rated, 194°F(90°C)

\* Based on NEC Table 310-16 1996 (Not more than 3 insulated conductors in a raceway at ambient temperature of 30° C) for the largest tap wire size.

**Warning:** Cancer and Reproductive Harm - [www.P65Warnings.ca.gov](http://www.P65Warnings.ca.gov).

**Advertencia:** Cáncer y Daño Reproductivo - [www.P65Warnings.ca.gov](http://www.P65Warnings.ca.gov).

One year limited warranty. See [idealind.com](http://idealind.com) for more information.

Garantía limitada de un año. Visite [www.idealind.com](http://www.idealind.com) para obtener detalles de la garantía.



**IDEAL INDUSTRIES, INC.**

1375 Park Avenue • Sycamore, Illinois 60178 • 815.895.5181 • [www.idealind.com](http://www.idealind.com)

ALL IDEAL Customers

2/9/23

Subject: **The Buchanan B-TAP® splice/tap connectors meet the 2020 NEC article 230.46 requirement for “line side applications”**

The Buchanan B-TAP® brand of insulation piercing connectors which correspond to part numbers beginning with “BTC” meet the requirements of article 230.46 of the 2020 NEC. These products have already been tested to the newer requirements. The installation instructions are in the process of being updated to show the required notation: “suitable for use on the line side of the service equipment”. This change will take a few weeks to get into our production.

In addition, the marking “SR” will be added to the product. That addition is in process and will take a few months to complete.

This notice will provide confirmation to the inspectors that B-TAP® products meet the requirements of the 2020 and 2023 NEC article 230.46 “Spliced and Tapped Conductors”.

Sushil Keswani

A handwritten signature in black ink, appearing to read "Sushil Keswani", written in a cursive style.

Director of Engineering  
IDEAL Industries, Inc.,

# ZMVV.E5238 - Wire Connectors and Soldering Lugs

Note: We are enhancing our systems and you may notice duplicate entries/missing/outdated data. During this interim period, please contact our Customer Service at <https://www.ul.com/about/locations>.

## Wire Connectors and Soldering Lugs

E5238

**IDEAL INDUSTRIES INC**

1375 Park Ave  
SYCAMORE, IL 60178 United States

*View model for additional information*

**Insulated butt splice crimp type connectors**, Model(s): [BVS1](#), [BVS2](#), [BVS5](#)

**Insulated flange spade type crimp cconnectors**, Model(s): [SV5-3.7](#), [SVL5-4](#), [SVL5-6](#)

**Insulated flange spade type crimp connectors**, Model(s): [FSNYD1-3.7](#), [FSNYD1-4](#), [FSNYD1-5](#), [FSNYD2-3.7](#), [FSNYD2-4](#), [FSNYD2-5](#), [FSNYD5-3.7](#), [FSNYD5-4](#), [FSNYD5-5](#)

**Insulated hook type crimp connectors**, Model(s): [HNYD1-3.7](#), [HNYD1-4](#), [HNYD1-5](#), [HNYD2-3.7](#), [HNYD2-4](#), [HNYD2-5](#), [HNYD5-3.7](#), [HNYD5-4](#), [HNYD5-5](#), [HVY1-3.7](#), [HVY1-4](#), [HVY1-5](#), [HVY2-4](#), [HVY2-5](#), [HVY5-3.7](#), [HVY5-4](#), [HVY5-5](#)

**Insulated locking spade crimp connectors**, Model(s): [LSNYD1-3.7](#), [LSNYD2-3.7](#), [LSNYD5-3.7](#), [LSNYD5-4](#), [LSNYD5-5](#), [LSNYDL1-4](#), [LSNYDL1-5](#), [LSNYDL2-4](#), [LSNYDL2-5](#)

**Insulated multiple stud ring type crimp connectors**, Model(s): [MSRNYD1-3753](#), [MSRNYD2-3753](#), [MSRNYD5-3753](#)

**Insulated parallel connectors**, Model(s): [PVT1](#), [PVT14](#), [PVT2](#), [PVT22](#), [PVT5](#), [PVT8](#)

**Insulated pin type connectors**, Model(s): [PTNYD1-12](#), [PTNYD2-12](#), [PTNYD5-13](#)

**Insulated ring type crimp connectors**, Model(s): [RNYB14-11](#), [RNYB22-11](#), [RNYD1-10](#), [RNYD1-3.2](#), [RNYD1-5](#), [RNYD1-6](#), [RNYD1-8](#), [RNYD2-10](#), [RNYD2-2](#), [RNYD2-3.2](#), [RNYD2-6](#), [RNYD2-8](#), [RNYD5-10](#), [RNYD5-12](#), [RNYD5-3.2](#), [RNYD5-3.7](#), [RNYD5-5](#), [RNYD5-6](#), [RNYD5-8](#), [RNYDL1-3.7](#), [RNYDL1-4](#), [RNYDL2-3.7](#), [RNYDL2-4](#), [RNYDL5-3.7](#), [RNYDL5-4](#), [RNYDM2-3.7](#), [RNYDS1-3.7](#), [RNYDS1-4](#), [RNYDS2-4](#), [RNYDS2-5](#), [RNYDS5-4](#), [RV1-3.2](#), [RV1-5](#), [RV1-6](#), [RV2-3.2](#), [RV5-10](#), [RV5-3.7](#), [RV5-5](#), [RV5-6](#), [RV5-8](#), [RVL1-4](#), [RVL2-4](#), [RVL5-4](#), [RVM1-3.7](#), [RVM2-3.7](#), [RVY1-3.2](#)

**Insulated spade type crimp connectors**, Model(s): [SNYD1-3.2](#), [SNYD5-3.7](#), [SNYD5-5](#), [SNYDL1-3.7](#), [SNYDL1-4](#), [SNYDL2-3.7](#), [SNYDL2-4](#), [SNYDL2-5](#), [SNYDL5-4](#), [SNYDLL1-3.7](#), [SNYDLL2-3.7](#), [SNYDM1-4](#), [SNYDM2-4](#), [SNYDS1-5](#), [SNYDS2-5](#), [SVL1-3.7](#), [SVL1-5](#), [SVL2-3.7](#), [SVL2-5](#), [SVM1-4](#), [SVM2-4](#), [SVY1-3.2](#), [SVY2-3.2](#), [SVY5-3.7](#), [SVY5-5](#), [SVYL1-3.7](#), [SVYL1-4](#), [SVYL2-3.7](#), [SVYL2-4](#), [SVYL2-5](#), [SVYL5-4](#), [SVYLL1-3.7](#), [SVYLL2-3.7](#), [SVYM1-4](#), [SVYM2-4](#), [SVYS1-5](#), [SVYS2-5](#), [SVYS5-4](#)

**Insulated splice connectors**, Model(s): [PB1-](#), [PB2-](#), [PB5-](#)

**Insulating caps or covers, for use on manufacturer`s splice caps, for 2006-S, 2008-S connectors**, Model(s): [2007](#)

**Insulating caps or covers, for use on manufacturer`s splice caps, for 2011-S connector**, Model(s): [2014](#)

**Listed pressure cable connectors**, Model(s): [BHT1](#), [BHT2](#), [BHT5](#), [BN1](#), [BN2](#), [BN5](#), [BNT1-16](#), [BNT14](#), [BNT2-16](#), [BNT22](#), [BNT5-20](#), [BNT8](#), [BNYDF1](#), [BNYDF2](#), [BNYDF5](#), [BNYT1](#), [BNYT2](#), [BNYT5](#), [BV1](#), [BV2](#), [BV5](#), [BVT14](#), [BVT22](#), [BVT8](#)

**Listed pressure ring terminal connectors**, Model(s): [RNYB14-8](#), [RNYB8-11](#), [RNYBL22-5](#), [RNYBL22-6](#)

**Listed splicing wire connectors**, Model(s): [L12](#), [L13](#), [L15](#)

**Non-insulated flange spade crimp connectors**, Model(s): [FSN1-3.7](#), [FSN1-4](#), [FSN1-5](#), [FSN2-3.7](#), [FSN2-4](#), [FSN2-5](#), [FSN5-3.7](#), [FSN5-4](#), [FSN5-5](#), [FSNB1-3.7](#), [FSNB1-4](#), [FSNB1-5](#), [FSNB2-3.7](#), [FSNB2-4](#), [FSNB2-5](#), [FSNB5-3.7](#), [FSNB5-4](#), [FSNB5-5](#), [FSNLI1-3.7](#), [FSNLI2-5](#)

**Non-insulated hook crimp connectors**, Model(s): [HN1-4](#), [HN1-5](#), [HN2-3.7](#), [HN2-4](#), [HN2-5](#), [HN5-3.7](#), [HN5-4](#), [HN5-5](#)

**Non-insulated locking type crimp connectors**, Model(s): [LSN1-3.7](#), [LSN2-3.7](#), [LSN5-3.7](#), [LSN5-4](#), [LSN5-5](#), [LSN5-6](#), [LSNLI1-4](#), [LSNLI1-5](#), [LSNLI2-5](#)

**Non-insulated multiple stud ring type crimp connectors**, Model(s): [MSRNB1-3753](#)

**Non-insulated parallel crimp connectors**, Model(s): [PNT 1](#), [PNT 14](#), [PNT 2](#), [PNT 22](#), [PNT 5](#), [PNT 8](#), [PNT1](#), [PNT2](#), [PNT5](#)

**Non-insulated pin type crimp connectors**, Model(s): [PTN1-12](#), [PTN2-12](#), [PTN5-13](#)

**Non-insulated ring type crimp connector**, Model(s): [RNB1-10](#), [RNB1-3.2](#), [RNB14-11](#), [RNB14-12](#), [RNB14-16](#), [RNB1-6](#), [RNB1-8](#), [RNB2-10](#), [RNB2-2](#), [RNB2-6](#), [RNB5-12](#), [RNB8-12](#), [RNB1-4](#)

**Non-insulated ring type crimp connectors**, Model(s): [RNB1-3.2](#), [RNB14-10](#), [RNB14-5](#), [RNB14-8](#), [RNB1-5](#), [RNB2-10](#), [RNB22-10](#), [RNB22-12](#), [RNB22-8](#), [RNB2-3.2](#), [RNB2-8](#), [RNB5-10](#), [RNB5-3.2](#), [RNB5-3.7](#), [RNB5-3.7](#), [RNB5-5](#), [RNB5-6](#), [RNB5-8](#), [RNB8-10](#), [RNB8-11](#), [RNB8-16](#), [RNB8-8](#), [RNB1-3.7](#), [RNB1-4](#), [RNB1-5](#), [RNB1-6](#), [RNB1-8](#), [RNB1-10](#), [RNB1-12](#), [RNB1-16](#), [RNB1-20](#), [RNB1-22](#), [RNB1-25](#), [RNB1-30](#), [RNB1-35](#), [RNB1-40](#), [RNB1-45](#), [RNB1-50](#), [RNB1-55](#), [RNB1-60](#), [RNB1-65](#), [RNB1-70](#), [RNB1-75](#), [RNB1-80](#), [RNB1-85](#), [RNB1-90](#), [RNB1-95](#), [RNB1-100](#), [RNB1-105](#), [RNB1-110](#), [RNB1-115](#), [RNB1-120](#), [RNB1-125](#), [RNB1-130](#), [RNB1-135](#), [RNB1-140](#), [RNB1-145](#), [RNB1-150](#), [RNB1-155](#), [RNB1-160](#), [RNB1-165](#), [RNB1-170](#), [RNB1-175](#), [RNB1-180](#), [RNB1-185](#), [RNB1-190](#), [RNB1-195](#), [RNB1-200](#), [RNB1-205](#), [RNB1-210](#), [RNB1-215](#), [RNB1-220](#), [RNB1-225](#), [RNB1-230](#), [RNB1-235](#), [RNB1-240](#), [RNB1-245](#), [RNB1-250](#), [RNB1-255](#), [RNB1-260](#), [RNB1-265](#), [RNB1-270](#), [RNB1-275](#), [RNB1-280](#), [RNB1-285](#), [RNB1-290](#), [RNB1-295](#), [RNB1-300](#), [RNB1-305](#), [RNB1-310](#), [RNB1-315](#), [RNB1-320](#), [RNB1-325](#), [RNB1-330](#), [RNB1-335](#), [RNB1-340](#), [RNB1-345](#), [RNB1-350](#), [RNB1-355](#), [RNB1-360](#), [RNB1-365](#), [RNB1-370](#), [RNB1-375](#), [RNB1-380](#), [RNB1-385](#), [RNB1-390](#), [RNB1-395](#), [RNB1-400](#), [RNB1-405](#), [RNB1-410](#), [RNB1-415](#), [RNB1-420](#), [RNB1-425](#), [RNB1-430](#), [RNB1-435](#), [RNB1-440](#), [RNB1-445](#), [RNB1-450](#), [RNB1-455](#), [RNB1-460](#), [RNB1-465](#), [RNB1-470](#), [RNB1-475](#), [RNB1-480](#), [RNB1-485](#), [RNB1-490](#), [RNB1-495](#), [RNB1-500](#), [RNB1-505](#), [RNB1-510](#), [RNB1-515](#), [RNB1-520](#), [RNB1-525](#), [RNB1-530](#), [RNB1-535](#), [RNB1-540](#), [RNB1-545](#), [RNB1-550](#), [RNB1-555](#), [RNB1-560](#), [RNB1-565](#), [RNB1-570](#), [RNB1-575](#), [RNB1-580](#), [RNB1-585](#), [RNB1-590](#), [RNB1-595](#), [RNB1-600](#), [RNB1-605](#), [RNB1-610](#), [RNB1-615](#), [RNB1-620](#), [RNB1-625](#), [RNB1-630](#), [RNB1-635](#), [RNB1-640](#), [RNB1-645](#), [RNB1-650](#), [RNB1-655](#), [RNB1-660](#), [RNB1-665](#), [RNB1-670](#), [RNB1-675](#), [RNB1-680](#), [RNB1-685](#), [RNB1-690](#), [RNB1-695](#), [RNB1-700](#), [RNB1-705](#), [RNB1-710](#), [RNB1-715](#), [RNB1-720](#), [RNB1-725](#), [RNB1-730](#), [RNB1-735](#), [RNB1-740](#), [RNB1-745](#), [RNB1-750](#), [RNB1-755](#), [RNB1-760](#), [RNB1-765](#), [RNB1-770](#), [RNB1-775](#), [RNB1-780](#), [RNB1-785](#), [RNB1-790](#), [RNB1-795](#), [RNB1-800](#), [RNB1-805](#), [RNB1-810](#), [RNB1-815](#), [RNB1-820](#), [RNB1-825](#), [RNB1-830](#), [RNB1-835](#), [RNB1-840](#), [RNB1-845](#), [RNB1-850](#), [RNB1-855](#), [RNB1-860](#), [RNB1-865](#), [RNB1-870](#), [RNB1-875](#), [RNB1-880](#), [RNB1-885](#), [RNB1-890](#), [RNB1-895](#), [RNB1-900](#), [RNB1-905](#), [RNB1-910](#), [RNB1-915](#), [RNB1-920](#), [RNB1-925](#), [RNB1-930](#), [RNB1-935](#), [RNB1-940](#), [RNB1-945](#), [RNB1-950](#), [RNB1-955](#), [RNB1-960](#), [RNB1-965](#), [RNB1-970](#), [RNB1-975](#), [RNB1-980](#), [RNB1-985](#), [RNB1-990](#), [RNB1-995](#), [RNB1-1000](#), [RNB1-1005](#), [RNB1-1010](#), [RNB1-1015](#), [RNB1-1020](#), [RNB1-1025](#), [RNB1-1030](#), [RNB1-1035](#), [RNB1-1040](#), [RNB1-1045](#), [RNB1-1050](#), [RNB1-1055](#), [RNB1-1060](#), [RNB1-1065](#), [RNB1-1070](#), [RNB1-1075](#), [RNB1-1080](#), [RNB1-1085](#), [RNB1-1090](#), [RNB1-1095](#), [RNB1-1100](#), [RNB1-1105](#), [RNB1-1110](#), [RNB1-1115](#), [RNB1-1120](#), [RNB1-1125](#), [RNB1-1130](#), [RNB1-1135](#), [RNB1-1140](#), [RNB1-1145](#), [RNB1-1150](#), [RNB1-1155](#), [RNB1-1160](#), [RNB1-1165](#), [RNB1-1170](#), [RNB1-1175](#), [RNB1-1180](#), [RNB1-1185](#), [RNB1-1190](#), [RNB1-1195](#), [RNB1-1200](#), [RNB1-1205](#), [RNB1-1210](#), [RNB1-1215](#), [RNB1-1220](#), [RNB1-1225](#), [RNB1-1230](#), [RNB1-1235](#), [RNB1-1240](#), [RNB1-1245](#), [RNB1-1250](#), [RNB1-1255](#), [RNB1-1260](#), [RNB1-1265](#), [RNB1-1270](#), [RNB1-1275](#), [RNB1-1280](#), [RNB1-1285](#), [RNB1-1290](#), [RNB1-1295](#), [RNB1-1300](#), [RNB1-1305](#), [RNB1-1310](#), [RNB1-1315](#), [RNB1-1320](#), [RNB1-1325](#), [RNB1-1330](#), [RNB1-1335](#), [RNB1-1340](#), [RNB1-1345](#), [RNB1-1350](#), [RNB1-1355](#), [RNB1-1360](#), [RNB1-1365](#), [RNB1-1370](#), [RNB1-1375](#), [RNB1-1380](#), [RNB1-1385](#), [RNB1-1390](#), [RNB1-1395](#), [RNB1-1400](#), [RNB1-1405](#), [RNB1-1410](#), [RNB1-1415](#), [RNB1-1420](#), [RNB1-1425](#), [RNB1-1430](#), [RNB1-1435](#), [RNB1-1440](#), [RNB1-1445](#), [RNB1-1450](#), [RNB1-1455](#), [RNB1-1460](#), [RNB1-1465](#), [RNB1-1470](#), [RNB1-1475](#), [RNB1-1480](#), [RNB1-1485](#), [RNB1-1490](#), [RNB1-1495](#), [RNB1-1500](#), [RNB1-1505](#), [RNB1-1510](#), [RNB1-1515](#), [RNB1-1520](#), [RNB1-1525](#), [RNB1-1530](#), [RNB1-1535](#), [RNB1-1540](#), [RNB1-1545](#), [RNB1-1550](#), [RNB1-1555](#), [RNB1-1560](#), [RNB1-1565](#), [RNB1-1570](#), [RNB1-1575](#), [RNB1-1580](#), [RNB1-1585](#), [RNB1-1590](#), [RNB1-1595](#), [RNB1-1600](#), [RNB1-1605](#), [RNB1-1610](#), [RNB1-1615](#), [RNB1-1620](#), [RNB1-1625](#), [RNB1-1630](#), [RNB1-1635](#), [RNB1-1640](#), [RNB1-1645](#), [RNB1-1650](#), [RNB1-1655](#), [RNB1-1660](#), [RNB1-1665](#), [RNB1-1670](#), [RNB1-1675](#), [RNB1-1680](#), [RNB1-1685](#), [RNB1-1690](#), [RNB1-1695](#), [RNB1-1700](#), [RNB1-1705](#), [RNB1-1710](#), [RNB1-1715](#), [RNB1-1720](#), [RNB1-1725](#), [RNB1-1730](#), [RNB1-1735](#), [RNB1-1740](#), [RNB1-1745](#), [RNB1-1750](#), [RNB1-1755](#), [RNB1-1760](#), [RNB1-1765](#), [RNB1-1770](#), [RNB1-1775](#), [RNB1-1780](#), [RNB1-1785](#), [RNB1-1790](#), [RNB1-1795](#), [RNB1-1800](#), [RNB1-1805](#), [RNB1-1810](#), [RNB1-1815](#), [RNB1-1820](#), [RNB1-1825](#), [RNB1-1830](#), [RNB1-1835](#), [RNB1-1840](#), [RNB1-1845](#), [RNB1-1850](#), [RNB1-1855](#), [RNB1-1860](#), [RNB1-1865](#), [RNB1-1870](#), [RNB1-1875](#), [RNB1-1880](#), [RNB1-1885](#), [RNB1-1890](#), [RNB1-1895](#), [RNB1-1900](#), [RNB1-1905](#), [RNB1-1910](#), [RNB1-1915](#), [RNB1-1920](#), [RNB1-1925](#), [RNB1-1930](#), [RNB1-1935](#), [RNB1-1940](#), [RNB1-1945](#), [RNB1-1950](#), [RNB1-1955](#), [RNB1-1960](#), [RNB1-1965](#), [RNB1-1970](#), [RNB1-1975](#), [RNB1-1980](#), [RNB1-1985](#), [RNB1-1990](#), [RNB1-1995](#), [RNB1-2000](#), [RNB1-2005](#), [RNB1-2010](#), [RNB1-2015](#), [RNB1-2020](#), [RNB1-2025](#), [RNB1-2030](#), [RNB1-2035](#), [RNB1-2040](#), [RNB1-2045](#), [RNB1-2050](#), [RNB1-2055](#), [RNB1-2060](#), [RNB1-2065](#), [RNB1-2070](#), [RNB1-2075](#), [RNB1-2080](#), [RNB1-2085](#), [RNB1-2090](#), [RNB1-2095](#), [RNB1-2100](#), [RNB1-2105](#), [RNB1-2110](#), [RNB1-2115](#), [RNB1-2120](#), [RNB1-2125](#), [RNB1-2130](#), [RNB1-2135](#), [RNB1-2140](#), [RNB1-2145](#), [RNB1-2150](#), [RNB1-2155](#), [RNB1-2160](#), [RNB1-2165](#), [RNB1-2170](#), [RNB1-2175](#), [RNB1-2180](#), [RNB1-2185](#), [RNB1-2190](#), [RNB1-2195](#), [RNB1-2200](#), [RNB1-2205](#), [RNB1-2210](#), [RNB1-2215](#), [RNB1-2220](#), [RNB1-2225](#), [RNB1-2230](#), [RNB1-2235](#), [RNB1-2240](#), [RNB1-2245](#), [RNB1-2250](#), [RNB1-2255](#), [RNB1-2260](#), [RNB1-2265](#), [RNB1-2270](#), [RNB1-2275](#), [RNB1-2280](#), [RNB1-2285](#), [RNB1-2290](#), [RNB1-2295](#), [RNB1-2300](#), [RNB1-2305](#), [RNB1-2310](#), [RNB1-2315](#), [RNB1-2320](#), [RNB1-2325](#), [RNB1-2330](#), [RNB1-2335](#), [RNB1-2340](#), [RNB1-2345](#), [RNB1-2350](#), [RNB1-2355](#), [RNB1-2360](#), [RNB1-2365](#), [RNB1-2370](#), [RNB1-2375](#), [RNB1-2380](#), [RNB1-2385](#), [RNB1-2390](#), [RNB1-2395](#), [RNB1-2400](#), [RNB1-2405](#), [RNB1-2410](#), [RNB1-2415](#), [RNB1-2420](#), [RNB1-2425](#), [RNB1-2430](#), [RNB1-2435](#), [RNB1-2440](#), [RNB1-2445](#), [RNB1-2450](#), [RNB1-2455](#), [RNB1-2460](#), [RNB1-2465](#), [RNB1-2470](#), [RNB1-2475](#), [RNB1-2480](#), [RNB1-2485](#), [RNB1-2490](#), [RNB1-2495](#), [RNB1-2500](#), [RNB1-2505](#), [RNB1-25](#)

**Splicing wire connectors**, Model(s): [H-1566](#), [H-1567](#), [H-1570](#), [H-1571](#), [H-1572](#), [H-1591](#), [H-1592](#), [H-1594](#)

**Terminal connectors**, Model(s): [10](#), [11](#), [22](#), [250](#), [300](#), [341](#), [342](#), [410 with insulating cap No. 415](#), [411 with insulating cap No. 417](#), [412 with insulating cap No. 417](#), [451](#), [452](#), [454](#), [48](#), [49](#), [49 Black](#), [53-B](#), [59B](#), [600](#), [71B#](#), [72B#](#), [73B#](#), [73B+](#), [74B](#), [76B](#), [76B+](#), [78B+](#), [82](#), [K-5504](#), [LSNL2-4](#), [M-3](#), [PV3-750](#), [PV3-750](#), [PV3-750](#), [PV4-750](#), [PV4-750](#), [PV4-750](#), [RNBL2-4](#), [RNBS14-6](#), [RNBS38-6](#), [RNBS38-8](#), [RNYB22-10](#), [RNYBS8-6](#), [RV2-6](#), [RVL2-5](#), [SV5-5](#), [WT1](#), [WT2](#), [WT3](#), [WT4](#), [WT41](#), [WT51](#), [WT52](#), [WT53](#), [WT54](#), [WT6](#)

**Terminal Connectors**, Model(s): [RNB22-11](#)

**Wire Connectors**, Model(s): [65](#), [653](#)

**Wire Connectors and Soldering Lugs**, Model(s): [L22](#), [L23](#), [L25](#), [PS10](#), [PS12](#), [PS2](#), [PS3](#), [PS4](#), [PS4S](#), [PS5](#), [PS6](#), [PS8](#)

# - The equipment (71B, 72B and 73B) were also evaluated to the requirements of UL 2043 and are suitable for use in air handling spaces.

\* - May be followed by suffix B, J, T or X.

NOTE - All models may be provided with or without prefix "V" or suffix "MP" or "V" and prefix "BP". All models may be followed by suffixes BT, UB or UF with or without a two or four digit number, with or without suffixes B, LP, NP, PF, PH, SP and/or T. Die Series terminals may be followed by Suffixes UI, UT, UF, US, or UB, with or without a two to four digit number, with or without Suffix T or B, followed by Suffixes SP, LP, NP, PF, or and/or NM, by PH or BE, with or without Suffixes NT, BS, and /or G.

---

The appearance of a company's name or product in this database does not in itself assure that products so identified have been manufactured under UL Solutions' Follow - Up Service. Only those products bearing the UL Mark should be considered to be Certified and covered under UL Solutions' Follow - Up Service. Always look for the Mark on the product.

UL Solutions permits the reproduction of the material contained in Product iQ subject to the following conditions: 1. The Guide Information, Assemblies, Constructions, Designs, Systems, and/or Certifications (files) must be presented in their entirety and in a non-misleading manner, without any manipulation of the data (or drawings). 2. The statement "Reprinted from Product iQ with permission from UL Solutions" must appear adjacent to the extracted material. In addition, the reprinted material must include a copyright notice in the following format: "©2023 UL LLC."



The right way to attach solar PV to trapezoidal roof profiles!

# S-5!<sup>®</sup>

## The Right Way!<sup>™</sup>



NOW AVAILABLE  
IN ALUMINUM

ProteaBracket<sup>™</sup>

### ProteaBracket<sup>™</sup>

A versatile bracket for mounting solar PV to trapezoidal roof profiles

ProteaBracket<sup>™</sup> is now made in aluminum. Still the most versatile trapezoidal metal roof attachment solution on the market, the S-5! ProteaBracket just got better!

The bracket features an adjustable attachment base and module attachment options to accommodate different roof profile dimensions and mounting options.

Our pre-applied EPDM gasket with peel and stick adhesive makes installation a snap, ensuring accurate and secure placement the first time.

With no messy sealants, faster installation, and a weather-proof fit, ProteaBracket offers you the most versatile solar attachment solution available.

ProteaBracket\* can be used for rail mounting or "direct-attach" with S-5! PVKIT<sup>™</sup>



### Features and Benefits

- 34% lighter - saves on shipping
- Stronger L-Foot<sup>™</sup>
- Load-tested for engineered application
- Corrosion-resistant materials
- Adjustable - Fits rib profiles up to 3"
- Peel-and-Stick prevents accidental shifting during installation
- Fully pre-assembled
- 25-year warranty\*



888-825-3432 | www.S-5.com

\*When ProteaBracket is used in conjunction with the S-5! PVKIT, an additional nut is required during installation.

\*See www.S-5.com for details.

# S-5!<sup>®</sup>

## The Right Way!<sup>™</sup>

ProteaBracket<sup>™</sup> is the perfect solar attachment solution for most trapezoidal rib, exposed-fastened metal roof profiles!

ProteaBracket<sup>™</sup> is compatible with common metal roofing materials and comes with a pre-applied EPDM gasket on the base.

**Note:** All four pre-punched holes must be used to achieve tested strength. Fasteners are provided.

For design assistance, ask your distributor, or visit [www.S-5.com](http://www.S-5.com) for the independent lab test data that can be used for load-critical designs and applications. Also, please visit our website for more information including metallurgical compatibilities and specifications.

S-5!<sup>®</sup> holding strength is unmatched in the industry.

### Multiple Attachment Options:

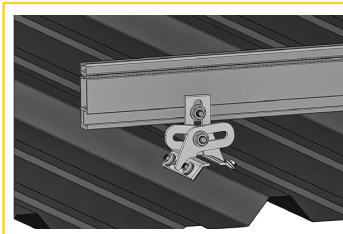

Side  
Mount Rail

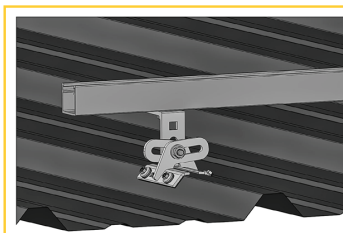

Bottom  
Mount Rail

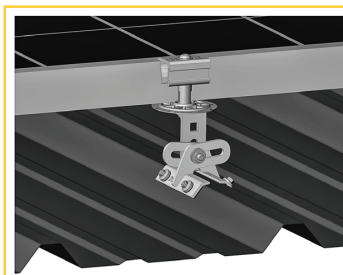

w/ S-5!  
PVKIT<sup>™</sup>  
(rail-less)

### ProteaBracket<sup>™</sup>

ProteaBracket<sup>™</sup> is still available in stainless steel.

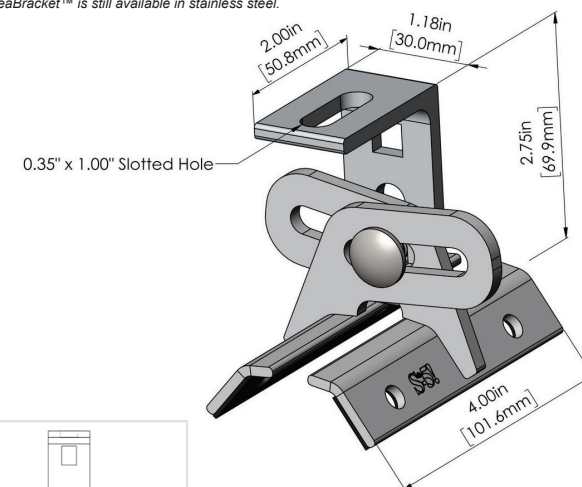

ProteaBracket fits profiles up to 3 inches

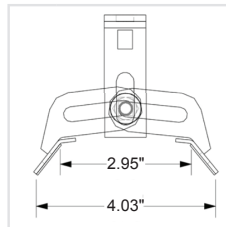

INSTALLATION:

- No surface preparation needed. (1) Wipe away excess oil and debris. (2) Peel off adhesive release paper. (3) Align and mount bracket directly onto crown of panel. (4) Secure ProteaBracket through pre-punched holes, using piercing-point S-5! screws.



ProteaBracket<sup>™</sup> and the S-5! PVKIT<sup>™</sup> 2.0 mounted on a trapezoidal roof profile

S-5!<sup>®</sup> Warning! Please use this product responsibly!

Products are protected by multiple U.S. and foreign patents. For published data regarding holding strength, bolt torque, patents, and trademarks, visit the S-5! website at [www.S-5.com](http://www.S-5.com).

Copyright 2019, Metal Roof Innovations, Ltd. S-5! products are patent protected. S-5! aggressively protects its patents, trademarks, and copyrights. Version 07089.

Distributed by



# SOLARMOUNT



**SOLARMOUNT** is the professionals' choice for residential PV mounting applications. Every aspect of the system is designed for an easier, faster installation experience. **SOLARMOUNT** is a complete solution with revolutionary universal clamps, **FLASHKIT PRO**, full system UL 2703 certification and 25-year warranty. Not only is **SOLARMOUNT** easy to install, but best-in-class aesthetics make it the most attractive on any block!



New & Improved:  
**THE PROFESSIONALS' CHOICE**  
With Superior Aesthetics

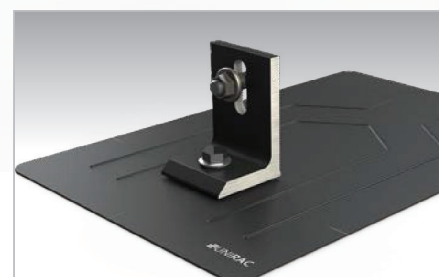

**NOW FEATURING FLASHKIT PRO**  
The Complete Roof Attachment Solution  
FEATURING SHED & SEAL TECHNOLOGY



**NOW WITH UNIVERSAL MIDCLAMPS**  
Accommodates 30mm-51mm module frames  
One tool, one-person installs are here!



**REVOLUTIONARY NEW ENDCLAMPS**  
Concealed design and included End Caps

## THE PROFESSIONALS' CHOICE FOR RESIDENTIAL RACKING

BEST INSTALLATION EXPERIENCE • CURB APPEAL • COMPLETE SOLUTION • UNIRAC SUPPORT

FOR QUESTIONS OR CUSTOMER SERVICE VISIT UNIRAC.COM OR CALL (505) 248-2702

# SOLARMOUNT



## BETTER DESIGNS

### TRUST THE INDUSTRY'S BEST DESIGN TOOL

Start the design process for every project in our U-Builder on-line design tool. It's a great way to save time and money.

## BETTER SYSTEMS

### ONE SYSTEM - MANY APPLICATIONS

Quickly set modules flush to the roof on steep pitched roofs. Orient a large variety of modules in Portrait or Landscape. Tilt the system up on flat or low slow roofs. Components available in mill, clear, and dark finishes to optimize your design financials and aesthetics.

## BETTER RESULTS

### MAXIMIZE PROFITABILITY ON EVERY JOB

Trust Unirac to help you minimize both system and labor costs from the time the job is quoted to the time your teams get off the roof. Faster installs. Less Waste. More Profits.

## BETTER SUPPORT

### WORK WITH THE INDUSTRIES MOST EXPERIENCED TEAM

Professional support for professional installers and designers. You have access to our technical support and training groups. Whatever your support needs, we've got you covered. Visit [Unirac.com/solarmount](http://Unirac.com/solarmount) for more information.



CONCEALED UNIVERSAL ENDCLAMPS

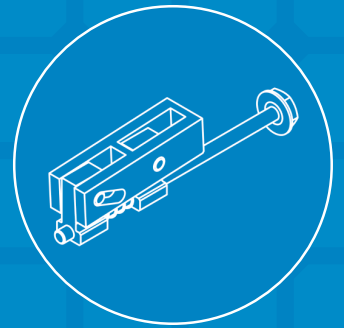

END CAPS INCLUDED WITH EVERY ENDCLAMP

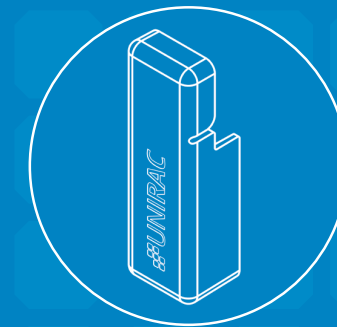

UNIVERSAL SELF-STANDING MIDCLAMPS

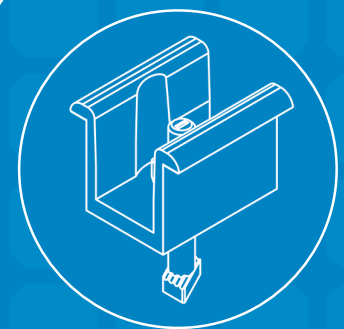

U-BUILDER ONLINE DESIGN TOOL SAVES TIME & MONEY  
Visit [design.unirac.com](http://design.unirac.com)

## UNIRAC CUSTOMER SERVICE MEANS THE HIGHEST LEVEL OF PRODUCT SUPPORT

UNMATCHED EXPERIENCE	CERTIFIED QUALITY	ENGINEERING EXCELLENCE	BANKABLE WARRANTY	DESIGN TOOLS	PERMIT DOCUMENTATION
----------------------	-------------------	------------------------	-------------------	--------------	----------------------

### TECHNICAL SUPPORT

Unirac's technical support team is dedicated to answering questions & addressing issues in real time. An online library of documents including engineering reports, stamped letters and technical data sheets greatly simplifies your permitting and project planning process.

### CERTIFIED QUALITY PROVIDER

Unirac is the only PV mounting vendor with ISO certifications for 9001:2008, 14001:2004 and OHSAS 18001:2007, which means we deliver the highest standards for fit, form, and function. These certifications demonstrate our excellence and commitment to first class business practices.

### BANKABLE WARRANTY

Don't leave your project to chance. Unirac has the financial strength to back our products and reduce your risk. Have peace of mind knowing you are providing products of exceptional quality. SOLARMOUNT is covered by a 25 year limited product warranty and a 5 year limited finish warranty.

ENHANCE YOUR REPUTATION WITH QUALITY RACKING SOLUTIONS BACKED BY ENGINEERING EXCELLENCE AND A SUPERIOR SUPPLY CHAIN

PUB2018AUG31 - PRINTED UPDATE FOR QUESTIONS OR CUSTOMER SERVICE VISIT UNIRAC.COM OR CALL (505) 248-2702



# Certificate of Compliance

Certificate: 70131735

Master Contract: 266909

Project: 80082031

Date Issued: 2021-06-02

Issued To: **Unirac**  
1411 Broadway NE  
Albuquerque, New Mexico, 87102  
United States

Attention: Klaus Nicolaedis

*The products listed below are eligible to bear the CSA Mark shown with adjacent indicators 'C' and 'US' for Canada and US or with adjacent indicator 'US' for US only or without either indicator for Canada only.*

Issued by: *Michael Hoffnagle*  
Michael Hoffnagle



## PRODUCTS

CLASS - C531302 - POWER SUPPLIES - PHOTOVOLTAICS-PV Racking and clamping systems  
CLASS - C531382 - POWER SUPPLIES - PHOTOVOLTAICS-PV Racking and clamping systems -  
Certified to US Standards

Models:	SM	-	SOLARMOUNT Flush-to-Roof is an extruded aluminum rail PV racking system that is installed parallel to the roof in landscape or portrait orientations.
	ULA	-	Unirac Large Array is a ground mount system using the SolarMount (SM) platform for the bonding and grounding of PV modules.

Solarmount



Certificate: 70131735  
Project: 80082031

Master Contract: 266909  
Date Issued: 2021-06-02

The system listed is designed to provide bonding/grounding, and mechanical stability for photovoltaic modules. The system is secured to the roof with the L-Foot components through the roofing material to building structure. Modules are secured to the racking system with stainless steel or aluminum mid clamps and Aluminum end clamps. The modules are bonded to the racking system with the stainless-steel bonding mid clamps with piercing points. The system is grounded with 10 AWG copper wire to bonding/grounding lugs. Fire ratings of Class A with Type 1, 2, 3, 10, 19, 22 or 25 for steep slope. Tested at 5" interstitial gap which allows installation at any stand-off height.

The grounding of the system is intended to comply with the latest edition of the National Electrical Code, to include NEC 250 & 690. Local codes compliance is required, in addition to national codes. All grounding/bonding connections are to be torqued in accordance with the Installation Manual and the settings used during the certification testing for the current edition of the project report.

The system may employ optimizers/micro-inverters and used for grounding when installed per installation instructions.

UL 2703 Mechanical Load ratings:

Downward Design Load (lb/ft <sup>2</sup> )	113.5
Upward Design Load (lb/ft <sup>2</sup> )	50.7
Down-Slope Load (lb/ft <sup>2</sup> )	16.13

Test Loads:

Downward Load (lb/ft <sup>2</sup> )	170.20
Upward Load (lb/ft <sup>2</sup> )	76.07
Down-Slope Load (lb/ft <sup>2</sup> )	24.2

## Unirac Large Array

ULA is a ground mount system using the SolarMount (SM) platform for the bonding and grounding of PV modules. ULA aluminum components merge with SM rails and installer-supplied steel pipe. The SM rail system is secured to the horizontal Pipe using the Rail Bracket components. The Rear and Front cap secures the horizontal Pipe to the vertical Pipe. The Front cap is also used to secure the Cross brace. A Slider is attached to the vertical Pipe to secure the Cross brace. The SM rails, caps, slider, rail brackets, and cross braces materials are 6105-T5 aluminum extrusion. Fasteners materials are 304 stainless steel. Horizontal and vertical pipe materials meet the minimum requirements of ASTM A53 for galvanized steel pipe in 2" and 3" diameter.

The mechanical load ratings from the SM test data will be applied to the ULA model.

Fire Testing is not applicable due to being a ground mount system.



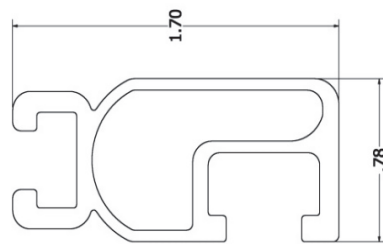
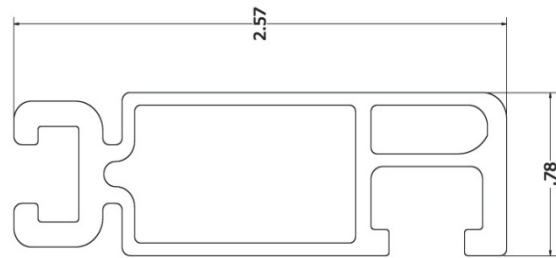
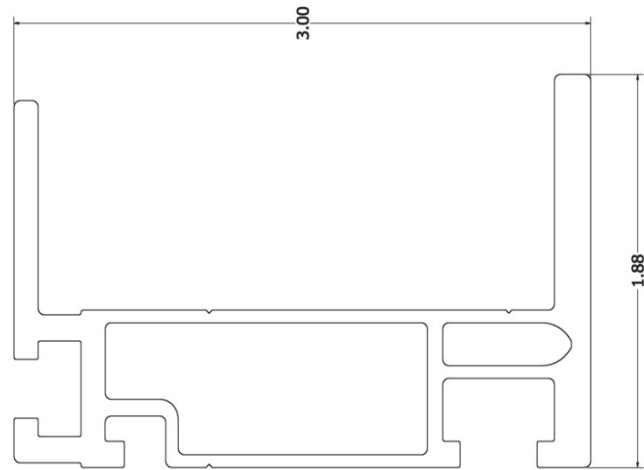

Properties	SOLARMOUNT Light	SOLARMOUNT Rail Profile 2	SOLARMOUNT HD	Units
BEAM HEIGHT	1.70	2.57	3.00	in
APPROX WEIGHT	0.491	0.728	1.271	plf
CROSS SECTION AREA	0.409	0.625	1.059	in <sup>2</sup>
SECTION MODULUS (X-AXIS)	0.15	0.363	0.898	in <sup>3</sup>
SECTION MODULUS (Y-AXIS)	0.067	0.113	0.221	in <sup>3</sup>
MOMENT OF INERTIA (X-AXIS)	0.13	0.467	1.45	in <sup>4</sup>
MOMENT OF INERTIA (Y-AXIS)	0.026	0.045	0.267	in <sup>4</sup>
RADIUS OF GYRATION (X-AXIS)	0.564	0.865	1.17	in
RADIUS OF GYRATION (Y-AXIS)	0.254	0.269	0.502	in

PAGE H3

# Certificate



Certificate no. **US 82160015 01**

**License Holder:**  
Unirac Inc.  
1411 Broadway NE  
Albuquerque NM 87102  
USA

**Manufacturing Plant:**  
Unirac Inc.  
1411 Broadway NE  
Albuquerque NM 87102  
USA

Test report no.: USA- 31440029 005  
Tested to: UL 2703:2015

Client Reference: Tom Young

**Certified Product:** Module Rack Mounting System

**License Fee - Units**

Model Designation: SolarMount (SM)

7

Max System Voltage of PV Module: 1000 VDC  
Max Size of PV Module: 20.8 sq.ft. surface area  
Max Overcurrent Protection Rating of PV Module:  
30 A when using the qualified grounding lugs;  
20 A when using the Enphase micro inverter EGC.

Fire Rating: Class A when installed with  
Type 1, Type 2, Type3, or Type 10 fire rated modules.

(continued)

Appendix: 1,1-5

7

Licensed Test mark:



Date of Issue  
(day/mo/yr)  
27/07/2016



March 28, 2022

Unirac  
1411 Broadway Blvd. NE  
Albuquerque, NM 87102

Attn.: Unirac - Engineering Department

Re: Engineering Certification for the Unirac U-Builder 2.0 SOLARMOUNT Flush Rail

PZSE, Inc. - Structural Engineers has reviewed the Unirac SOLARMOUNT rails, proprietary mounting system constructed from modular parts which is intended for rooftop installation of solar photovoltaic (PV) panels; and has reviewed the U-builder Online tool. This U-Builder software includes analysis for the SOLARMOUNT LIGHT rail, SOLARMOUNT STANDARD rail, and SOLARMOUNT HEAVY DUTY rail with Standard and Pro Series hardware. All information, data and analysis contained within are based on, and comply with the following codes and typical specifications:

1. Minimum Design Loads for Buildings and other Structures, ASCE/SEI 7-05 and ASCE/SEI 7-10
2. 2006-2015 International Building Code, by International Code Council, Inc.
3. 2006-2015 International Residential Code, by International Code Council, Inc.
4. AC428, Acceptance Criteria for Modular Framing Systems Used to Support Photovoltaic (PV) Panels, November 1, 2012 by ICC-ES.
5. 2015 Aluminum Design Manual, by The Aluminum Association, 2015

Following are typical specifications to meet the above code requirements:

- Design Criteria:** Ground Snow Load = 0 - 100 (psf)  
Basic Wind Speed = 85 - 190 (mph)  
Roof Mean Height = 0 - 60 (ft)  
Roof Pitch = 0 - 45 (degrees)  
Exposure Category = B, C & D
- Attachment Spacing:** Per U-builder Engineering report.
- Cantilever:** Maximum cantilever length is  $L/3$ , where "L" is the span noted in the U-Builder online tool.
- Clearance:** 2" to 10" clear from top of roof to top of PV panel.
- Tolerance(s):** 1.0" tolerance for any specified dimension in this report is allowed for installation.
- Installation Orientation:** See SOLARMOUNT Rail Flush Installation Guide.  
Landscape - PV Panel long dimension is parallel to ridge/eave line of roof and the PV panel is mounted on the long side.  
Portrait - PV Panel short dimension is parallel to ridge/eave line of roof and the PV panel is mounted on the short side.

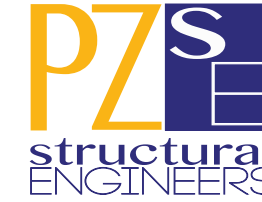

**Components and Cladding Roof Zones:**

The Components and Cladding Roof Zones shall be determined based on ASCE 7-05 and ASCE 7-10 Component and Cladding design.

- Notes:
- 1) U-builder Online tool analysis is only for Unirac SM SOLARMOUNT Rail Flush systems only and do not include roof capacity check.
  - 2) Risk Category II per ASCE 7-10.
  - 3) Topographic factor,  $k_{zt}$  is 1.0.
  - 4) Average parapet height is 0.0 ft.
  - 5) Wind speeds are LRFD values.
  - 6) Attachment spacing(s) apply to a seismic design category E or less.

**Design Responsibility:**

The U-Builder design software is intended to be used under the responsible charge of a registered design professional where required by the authority having jurisdiction. In all cases, this U-builder software should be used under the direction of a design professional with sufficient structural engineering knowledge and experience to be able to:

- Evaluate whether the U-Builder Software is applicable to the project, and
- Understand and determine the appropriate values for all input parameters of the U-Builder software.

This letter certifies that the Unirac SM SOLARMOUNT Rails Flush, when installed according to the U-Builder engineering report and the manufacture specifications, is in compliance with the above codes and loading criteria.

This certification excludes evaluation of the following components:

- 1) The structure to support the loads imposed on the building by the array; including, but not limited to: strength and deflection of structural framing members, fastening and/or strength of roofing materials, and/or the effects of snow accumulation on the structure.
- 2) The attachment of the SM SOLARMOUNT Rails to the existing structure.
- 3) The capacity of the solar module frame to resist the loads.

This requires additional knowledge of the building and is outside the scope of the certification of this racking system.

If you have any questions on the above, do not hesitate to call.

Prepared by:  
PZSE, Inc. – Structural Engineers  
Roseville, CA

