

Project Details

Name	Tara Neave	Date	05/16/2023
Location	440 Hayden Lane, Cameron, NC 28326	Total modules	21
Module	Mission Solar Energy: MSE395SX9R (40mm)	Total watts	8,295
Dimensions	Dimensions: 75.08" x 41.5" x 1.57" (1907.0mm x 1054.0mm x 40.0mm)	Attachments	46
ASCE	7-16	Rails per row	2

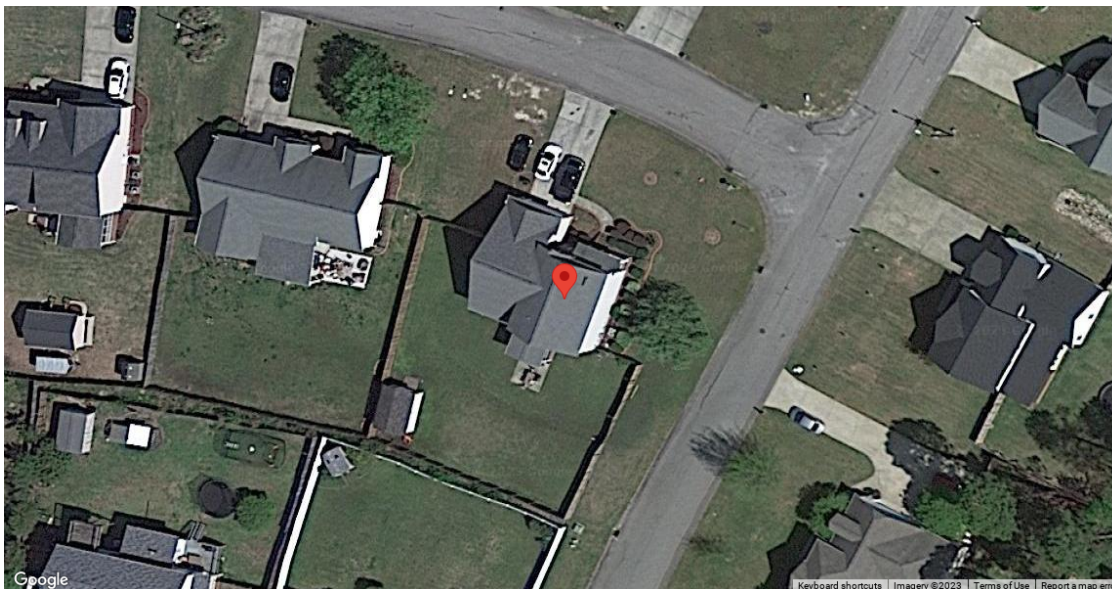

System Weight

Total system weight	1,169.2 lbs
Weight/attachment	25.4 lbs
Racking weight	150.7 lbs
Distributed weight	2.5 psf

Load Assumptions

Wind exposure	C
Wind speed	119 mph
Ground snow load	15 psf
Attachment spacing portrait	4.0'
Site Elevation	331.0 ft
S_{ps}	0.164

Roof Information

Roof Material Family	Comp Shingle	Roof material	Comp Shingle
Building height	25 ft	Roof attachment	Flashfoot2
		Staggered attachments	Yes
Roof slope	34 °	Attachment hardware	Square
Risk category	II		
Roof shape	Gable		
Specific gravity	0.42		

Span Details XR10 - Portrait

Zone	Module Position	Max span	Max cantilever
Zone 1/2e/2r	Normal	5' 5"	2' 2"
Zone 2n/3r	Normal	5' 5"	2' 2"
Zone 3e	Normal	5' 4"	2' 2"

Reaction Forces XR10 - Portrait

Zone	Module Position	Uplift (PSF)	Down (lbs)	Uplift (lbs)	Lateral (lbs)
Zone 1/2e/2r	Normal	16.3	189	249	70
Zone 2n/3r	Normal	19.4	189	285	70
Zone 3e	Normal	24.0	189	359	70

Roof Section 1

Details		Weights
Panels: 7	Provided rail: 56' [4 x 168"]	Total weight: 380.9 lbs
Rail orientation: East-West	Attachments: 15	Weight/attachment: 25.4 lbs
Panel orientation: Portrait	Splices: 2	Total Area: 153.7 sq ft
Entry type: Graphical	Clamps: 16	Distributed weight: 2.5 psf

Diagram

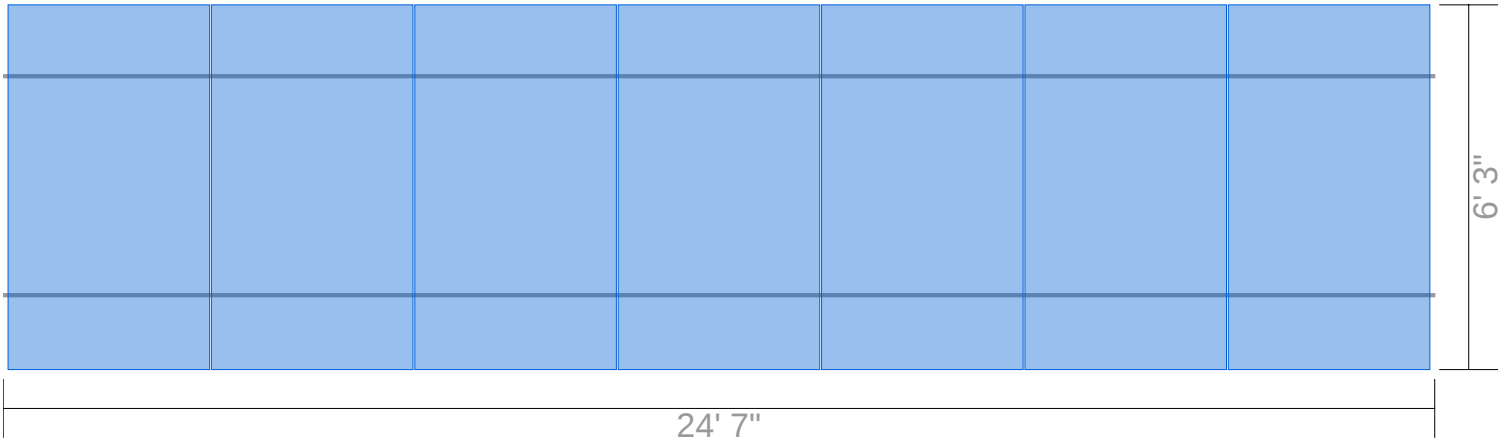

Segments

Identifier	Columns	Row length	Rail length	Cantilever	Rail	Attachments	Splices	Clamps
A	7	24' 7"	24' 7"	3"	56' [4 x 168"]	15	2	16

Roof Section 2

Details		Weights
Panels: 14	Provided rail: 168' [12 x 168"]	Total weight: 788.3 lbs
Rail orientation: East-West	Attachments: 31	Weight/attachment: 25.4 lbs
Panel orientation: Portrait	Splices: 6	Total Area: 308.8 sq ft
Entry type: Graphical	Clamps: 34	Distributed weight: 2.6 psf

Diagram

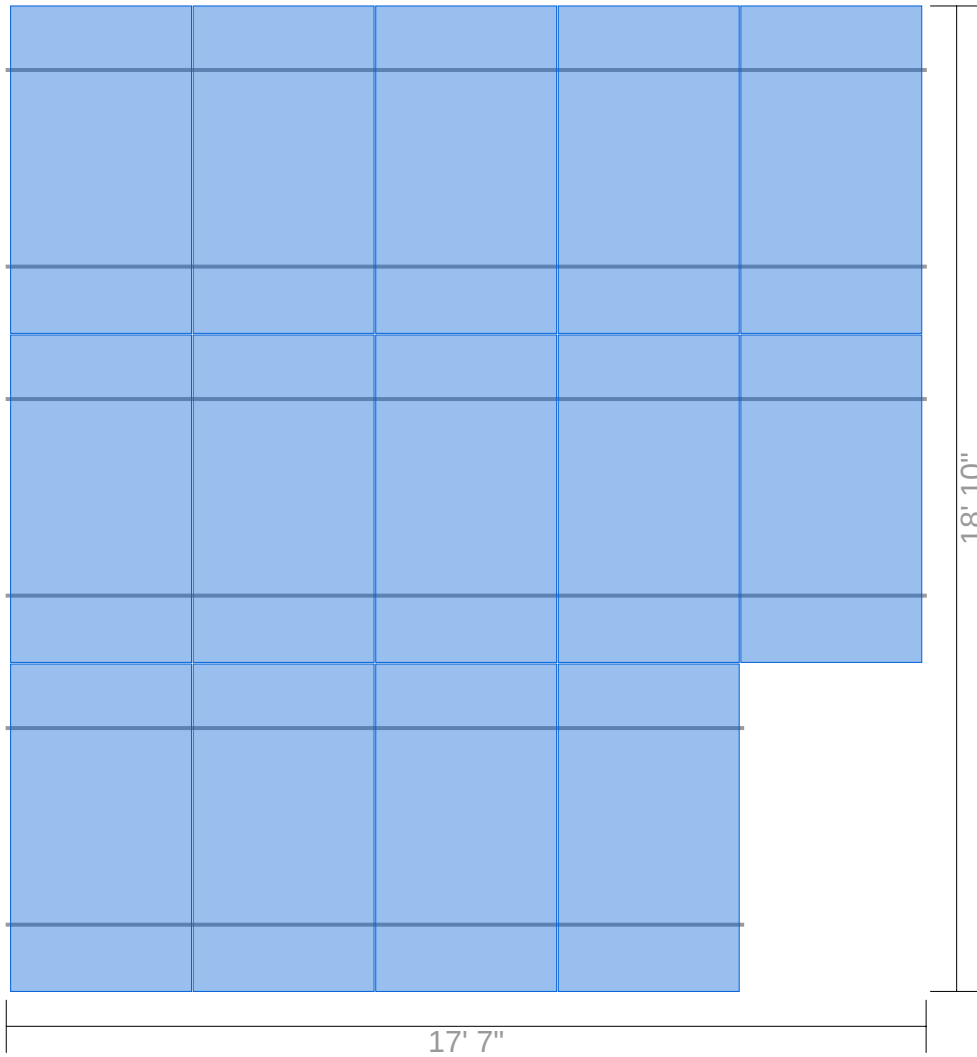

Segments

Identifier	Columns	Row length	Rail length	Cantilever	Rail	Attachments	Splices	Clamps	
A	5	17' 7"	17' 7"	10"	56' [4 x 168"]	11	2	12	
					Row segment totals (x 2) →	112' [8 x 168"]	22	4	24
B	4	14' 1"	14' 1"	1' 1"	56' [4 x 168"]	9	2	10	

Side View (portrait)

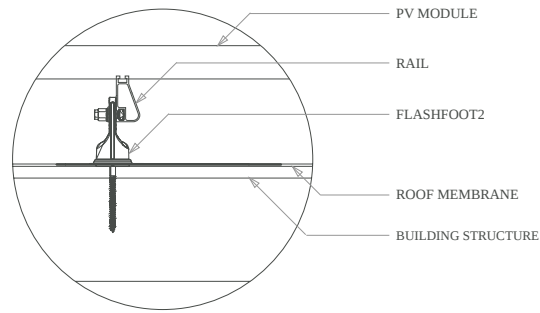
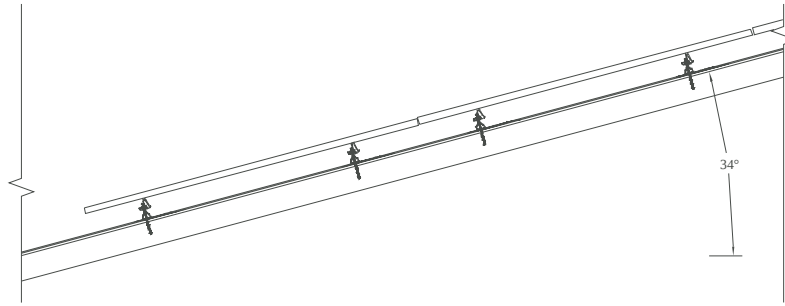

Front View (portrait)

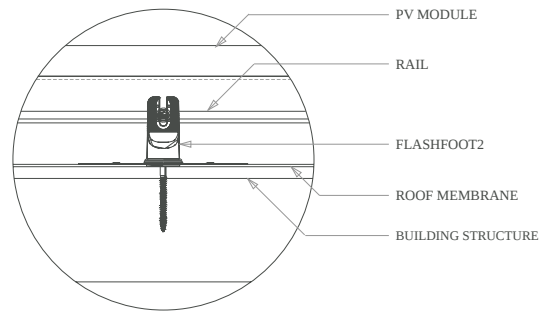
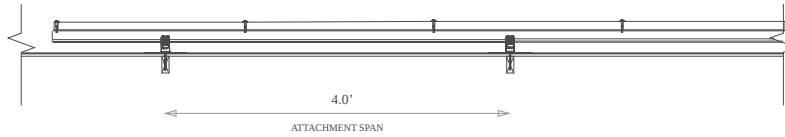

Splice Details

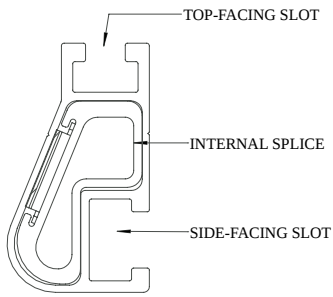

XR10

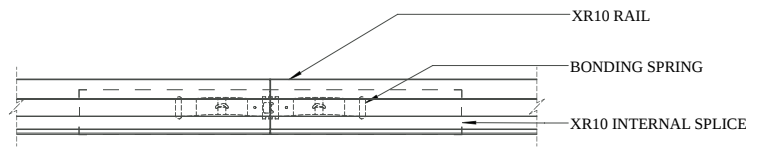

Splice Connection

Clamp Detail

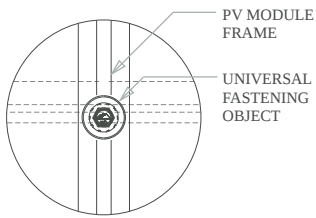

Mid Clamp, Plan

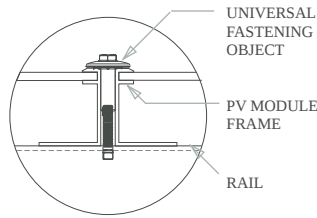

Mid Clamp, Front

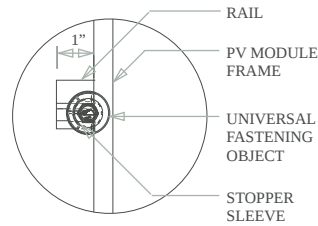

End Clamp, Plan

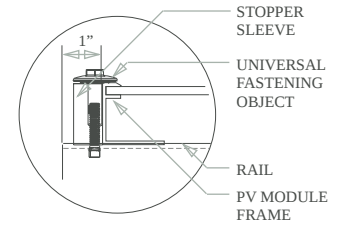

End Clamp, Front

FlashFoot2 Detail

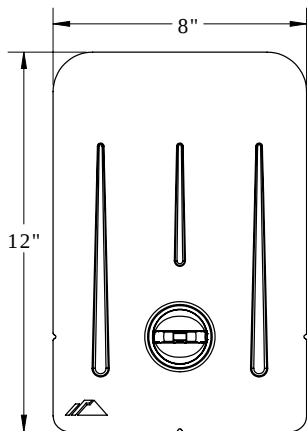

Plan View

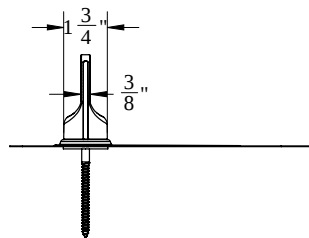

Side View

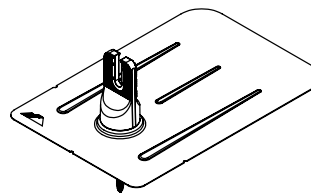

Perspective View

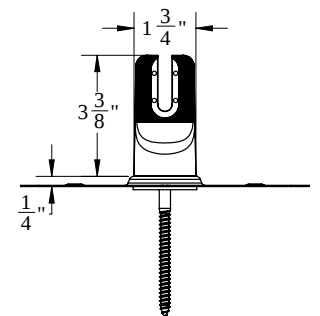

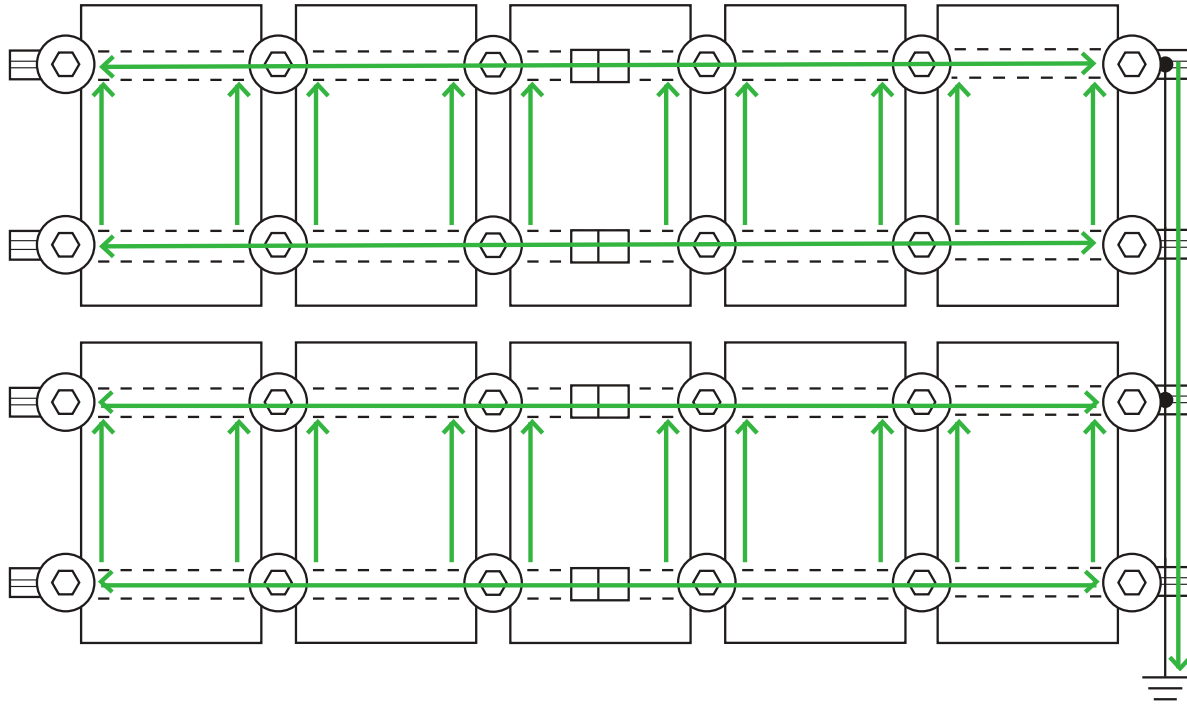

Front View

Grounding Diagram



 UFO Clamp

 Fault Current Ground Path

 Grounding Lug *

 Min 10 AWG Copper Wire *

 Bonded Splice (Rail Connection)

* Grounding Lugs and Wire are not required in systems using Enphase microinverters.

Bill of Materials

Part	Spares	Total Qty
-------------	---------------	------------------

Rails & Splices

XR-10-168B XR10, Rail 168" Black	0	16
XR10-BOSS-01-M1 Bonded Splice, XR10	0	8

Clamps & Grounding

UFO-CL-01-B1 Universal Module Clamp, Black	0	50
UFO-STP-40MM-B1 Stopper Sleeve, 40MM, Black	0	16
XR-LUG-03-A1 Grounding Lug, Low Profile	0	4

Attachments

FF2-02-B2 FlashFoot2, Black	0	46
BHW-SQ-02-A1 Square-Bolt Bonding Hardware	0	46

ATTACHMENTS

PRE-INSTALLATION

- Verify module compatibility. See [Page 21](#) for info.

TOOLS REQUIRED

- Cordless Drill (non-impact)
- Impact Driver (for lag bolts)
- Torque Wrench (0-250 in-lbs)
- 7/16" Socket
- 1/2" Socket
- 9/16" Socket
- 7/32" Drill Bit
- 3/8" Socket
- 1/8" Drill Bit
- 1/4" Drill Bit
- T30 Bit
- Channel Lock Pliers
- #3 Phillips Bit
- 3/16" Hex Bit

BONDING HARDWARE TORQUE VALUES

Please refer to each attachment's individual section for full details on all torque values and instructions.

- 3/8" Bonding Hardware Nuts (7/16" Socket): 250 in-lbs
- All Tile Hook Carriage Bolts (7/16" Socket): 132 in-lbs
- Flat Roof Attachment Nuts (9/16" Socket): 250 in-lbs
- Lynx Set Screw (3/16" Hex Drive): 150 in-lbs
- Lynx Flange Nut (1/2" Socket): 150 in-lbs

➤ If using previous version of Integrated Grounding Mid Clamps, End Clamps, Expansion Joints and for a list of approved 3rd party components please refer to Alternate Components Addendum (Version 1.9)

ATTACHMENTS

COMPOSITION SHINGLE



FlashFoot2

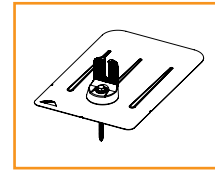

FlashVue

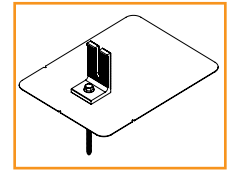

QM L-Mount

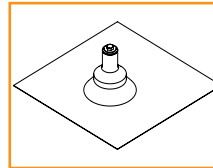

QM QBase

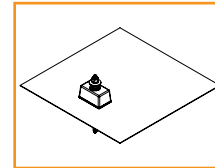

QM Classic Comp Mount

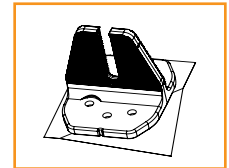

HUG (Halo UltraGrip)

TILE

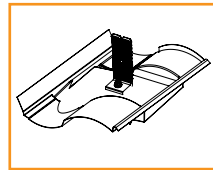

Knockout Tile

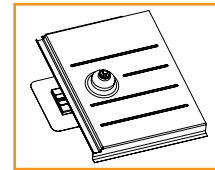

QM Tile Replacement

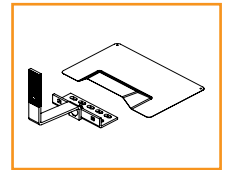

All Tile Hook and Flashing (optional)

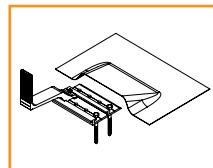

QM Quick Hook and Flashing (optional)

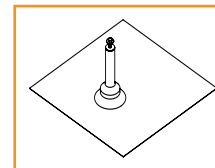

QM QBase Tile

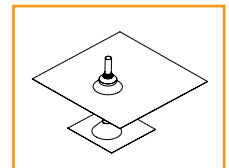

QM Tile Conduit Penetration

ADDITIONAL ROOF TYPES

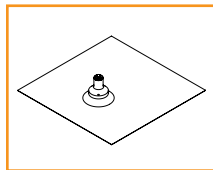

QM Qbase Shake - Slate - Metal Shingle

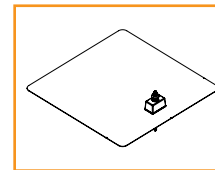

QM Classic Mount Shake

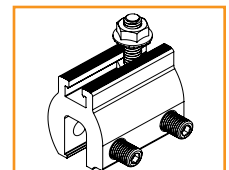

QM Lynx Metal Roof Attachment

LOW SLOPE ROOF

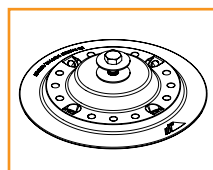

Flat Roof Attachment

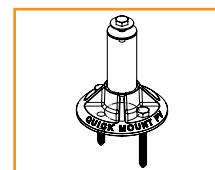

QM QBase Mount

COMPONENTS

PRE-INSTALLATION

- Verify module compatibility. See [Page 21](#) for info.

TOOLS REQUIRED

- Cordless Drill (non-impact)
- Impact Driver (for lag bolts)
- Torque Wrench (0-250 in-lbs)
- 7/16" Socket
- 1/2" Socket
- 9/16" Socket
- 7/32" Drill bit
- 1/8" Drill bit
- 1/4" Drill bit
- T30 Torx Bit
- Channel Lock Pliers
- #3 Phillips Bit
- Paddle Bit

BONDING HARDWARE TORQUE VALUES

Please refer to each attachment's individual section for full details on all torque values and instructions.

- Universal Fastening Object (7/16" Socket): 80 in-lbs
- Rail Grounding Lug Nut (7/16" Socket): 80 in-lbs
- Module Grounding Lug
 - Grounding Nut (7/16" Socket): 60 in-lbs
 - Grounding Lug Terminal Screws (7/16" Socket): 20 in-lbs
- Microinverter Kit Nuts (7/16" Socket): 80 in-lbs
- Frameless Module Kit Nuts (7/16" Socket): 80 in-lbs
- 3/8" Bonding Hardware Nuts (7/16" Socket): 250 in-lbs
- Contour Clamp (T-30 Torx Bit): 80 in-lbs

➤ Unless otherwise noted, all components have been evaluated for multiple use. They can be uninstalled and reinstalled in the same or new location.

COMPONENTS

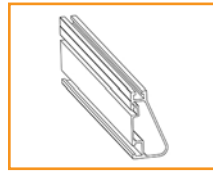

XR Rail



Wire Clip

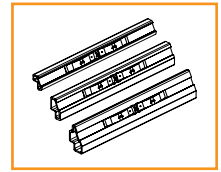

BOSS

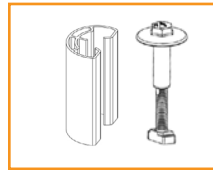

UFO and Stopper Sleeve (30-46MM)



CAMO

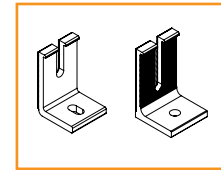

Ironridge L-Foot and QM L-Foot



End Cap

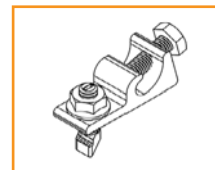

Rail Grounding Lug

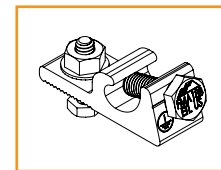

Module Grounding Lug

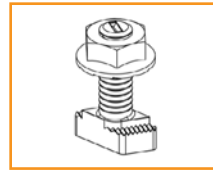

Microinverter Kit

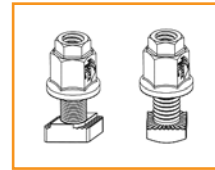

3/8" Bonding Hardware

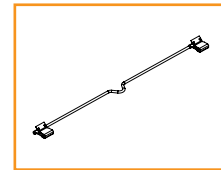

8" Bonding Jumper Single Use Only

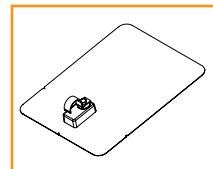

QM Classic Conduit Comp Mount

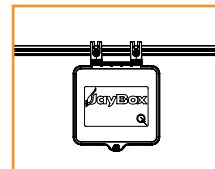

JAYBOX

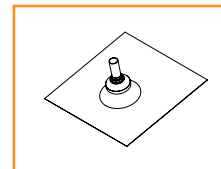

QM Composition Conduit Penetration

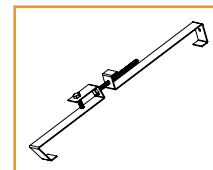

QM Tile Conduit Mount



Frameless End/Mid Clamp

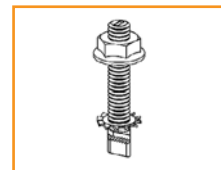

Frameless Module Kit

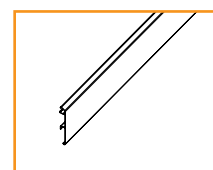

Contour Trim

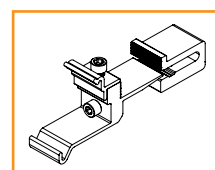

Contour Clamp

