

**PHOTOVOLTAIC ROOF MOUNT SYSTEM**

**CODE AND STANDARDS**

THE INSTALLATION OF SOLAR ARRAYS AND PHOTOVOLTAIC POWER SYSTEMS SHALL COMPLY WITH THE FOLLOWING CODES:

- 2020 NATIONAL ELECTRICAL CODE
- 2018 NORTH CAROLINA RESIDENTIAL CODE
- 2018 NORTH CAROLINA BUILDING CODE
- ALL OTHER ORDINANCE ADOPTED BY THE LOCAL GOVERNING AGENCIES

**SITE NOTES / OSHA REGULATION**

1. A LADDER SHALL BE IN PLACE FOR INSPECTION IN COMPLIANCE WITH OSHA REGULATIONS.
2. THE SOLAR PV INSTALLATION SHALL NOT OBSTRUCT ANY PLUMBING, MECHANICAL, OR BUILDING ROOF VENTS.
3. ROOFTOP MOUNTED PHOTOVOLTAIC PANELS AND MODULES SHALL BE TESTED, LISTED AND IDENTIFIED BY RECOGNIZED ELECTRICAL TESTING LABORATORY.
4. MODULES AND SUPPORT STRUCTURES SHALL BE GROUNDED
5. SOLAR INVERTER SHALL BE LISTED TO UL1741
6. ALL CONDUCTORS SHALL BE COPPER AND SHOULD BE 75 AND 90 DEG RATED
7. REMOVAL OF AN INTERACTIVE INVERTER OR OTHER EQUIPMENT SHALL NOT DISCONNECT THE BONDING CONNECTION BETWEEN THE GROUNDING ELECTRODE CONDUCTOR, THE PHOTOVOLTAIC SOURCE AND OUTPUT CIRCUIT GROUNDED CONDUCTORS.
8. LIVE PARTS OF PV SOURCE CIRCUITS AND PV OUTPUT CIRCUITS OVER 150V TO GROUND SHALL NOT BE ACCESSIBLE TO OTHER THAN QUALIFIED PERSONS WHILE ENERGIZED.
9. ALL PV MODULES AND ASSOCIATED EQUIPMENT AND WIRING SHALL BE PROTECTED FROM PHYSICAL DAMAGE.

**SOLAR CONTRACTOR**

1. MODULE CERTIFICATIONS INCLUDE UL1703, IEC61646, IEC61370.
2. IF APPLICABLE, MODULE GROUNDING LUGS MUST BE INSTALLED AT THE MARKED GROUNDING LUG HOLES PER THE MANUFACTURERS INSTALLATION REQUIREMENTS.
3. AS INDICATED BY DESIGN, OTHER NRTL LISTED MODULE GROUNDING DEVICES MAY BE USED IN PLACE OF STANDARD GROUNDING LUGS AS SHOWN IN MANUFACTURER DOCUMENTATION AND APPROVED BY THE AHJ.
4. ALL MICROINVERTERS, PHOTOVOLTAIC MODULES, AC COMBINERS, DC-AC CONVERTERS AND SOURCE CIRCUIT COMBINERS INTENDED FOR USE IN A PHOTOVOLTAIC POWER SYSTEM WILL BE IDENTIFIED AND LISTED FOR THE APPLICATION PER NEC690.4(B).
5. ALL SIGNAGE TO BE INSTALLED IN ACCORDANCE WITH LOCAL BUILDING CODE.
6. TERMINALS AND LUGS WILL BE TIGHTENED TO MANUFACTURER TORQUE SPECIFICATIONS (WHEN PROVIDED) IN ACCORDANCE WITH NEC CODE 110.14(D) ON ALL ELECTRICAL CONNECTIONS.
7. MAX DC VOLTAGE CALCULATED USING MANUFACTURER PROVIDED TEMP COEFFICIENT FOR VOC UNLESS NOT AVAILABLE.

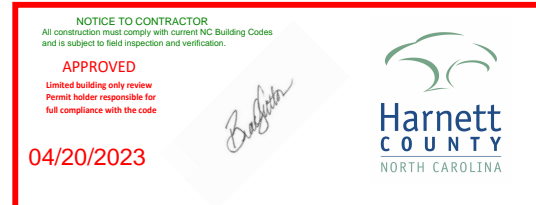

SR.#	PROJECT INFORMATION	
1	PV MODULES	31 x SOLARIA POWERXT 430R-PL
2	INVERTER	31 x IQ8PLUS-72-2-US
3	ROOF TYPE	ASPHALT SHINGLES
4	RACKING	PSR-B84 RAILS (BLACK)
5	MOUNTING TYPE	COMP MOUNT FLASHING (BLACK)
6	DC SIZE	13.33 KW
7	AC SIZE	8.99 KVA
SR.#	PROJECT INFORMATION	
1	PV1	DRAWING INDEX
2	PV2	SITE LAYOUT
3	PV3	STRING MAPPING
4	PV4	ELECTRICAL ONE LINE DIAGRAM
5	PV5	DETAILED ELECTRICAL WIRING SCHEMATIC
6	PV6	PV LABELS
7	PV7	BILL OF MATERIALS
8	PV8	ATTACHMENT DETAILS



5112 Departure Drive,  
Raleigh NC 27616  
O: 919.948.6474  
E: info@8msolar.com

**Customer Information:**

**Cory Kolek**  
29 Dekalb Court  
Fuquay-Varina NC 27526

**Customer Signature:**

**Sheet Name:**

Drawing Index

**JOB NUMBER:**

23-125-CK

**Date:**

04/05/2023

**Revision:**

A

**Sheet Size:**

ANSI C  
17" X 22"

**Sheet Number:**

PV1



**DESIGN CRITERIA**  
WIND SPEED: 135 MPH  
GROUND SNOW LOAD: 20 PSF  
WIND EXPOSURE FACTOR: B

**UTILITY COMPANY:**  
DUKE ENERGY  
**PERMIT ISSUER (AHJ):**  
HARNETT COUNTY

**SCOPE OF WORK**  
INSTALLATION OF UTILITY  
INTERACTIVE PHOTOVOLTAIC  
SOLAR SYSTEM.

**VICINITY MAP**

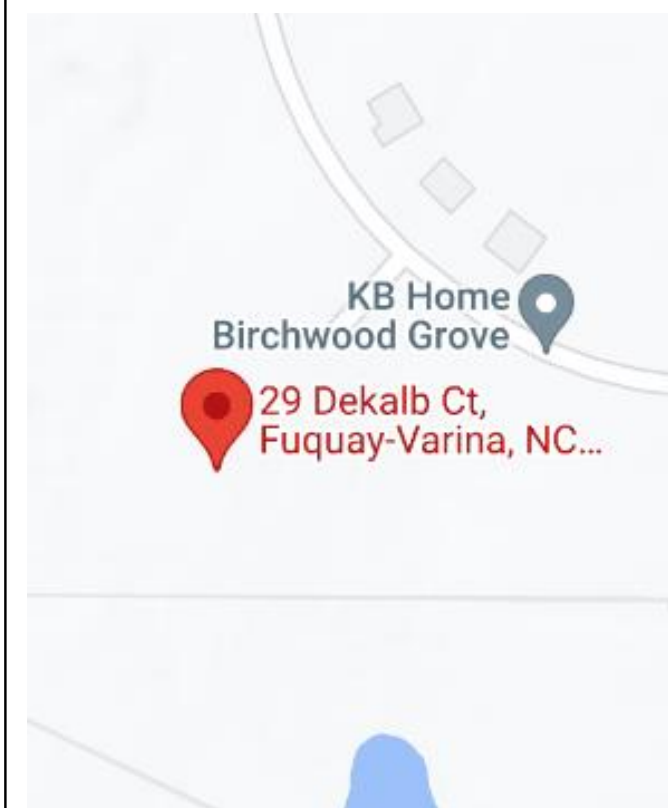

**TOP VIEW OF THE BUILDING**



ROOF DESCRIPTION			
ROOFS	PITCH	AZIMUTH	NO. OF MODULES
A	34°	302°	08
B	34°	213°	12
C	19°	213°	11
Vent			
		<ul style="list-style-type: none"> <li>Roof C has no vents</li> <li>No vents will be covered by PV modules during the installation</li> </ul>	

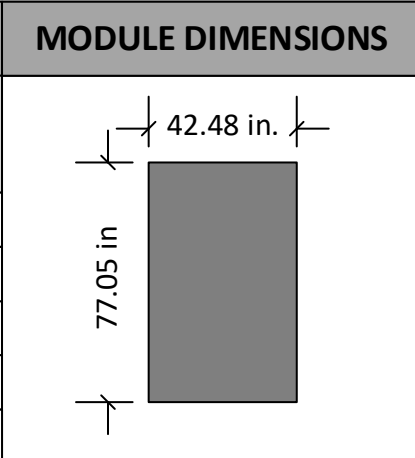

PV System Dead Load (Panel + Racking weight) / PV System Area (No. of panels x Weight of panel(lbs.) + Length of racking(ft.) x 1.15 lb.ft) / (No. of panels x Height x Width) = Total psf			
ROOFS	A	B	C
DEAD LOAD (PSF)	2.58	2.61	2.49

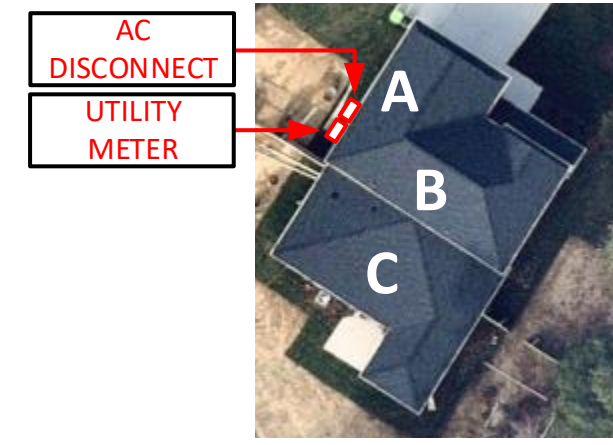

**SYSTEM DETAILS**

NUMBER OF PANELS : 31  
 PANELS MODEL : SOLARIA POWERXT 430R-PL  
 DC SIZE : 13.33 kW  
 AC SIZE : 8.99 kVA

5112 Departure Drive,  
 Raleigh NC 27616  
 O: 919.948.6474  
 E: info@8msolar.com

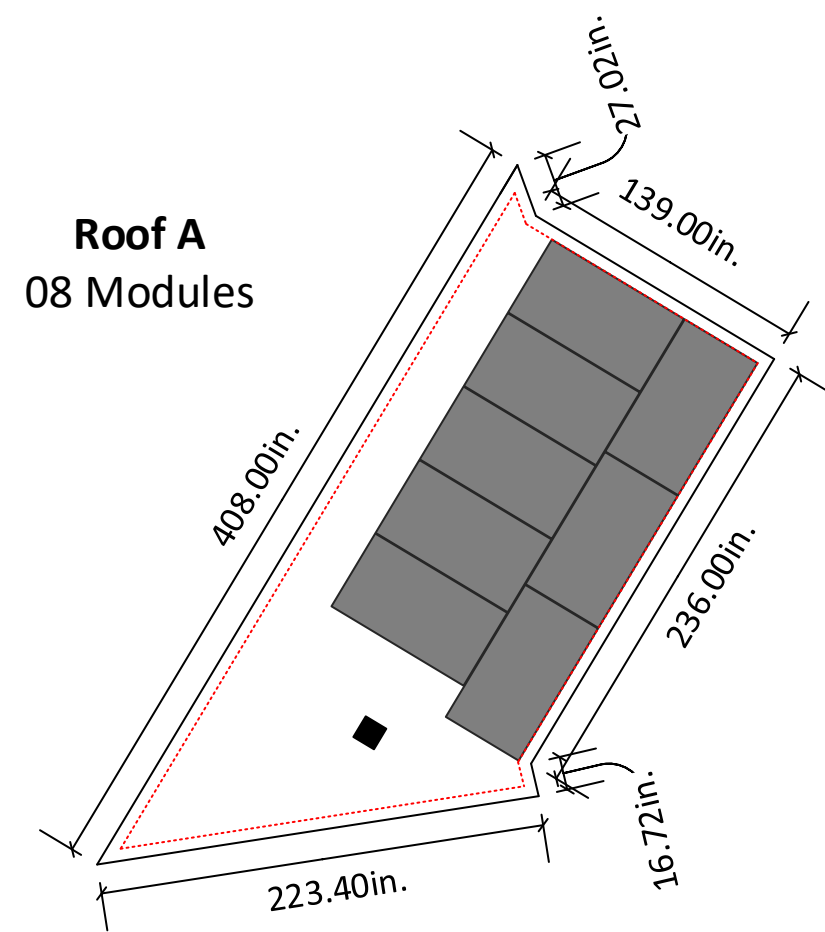

**Roof A**  
08 Modules

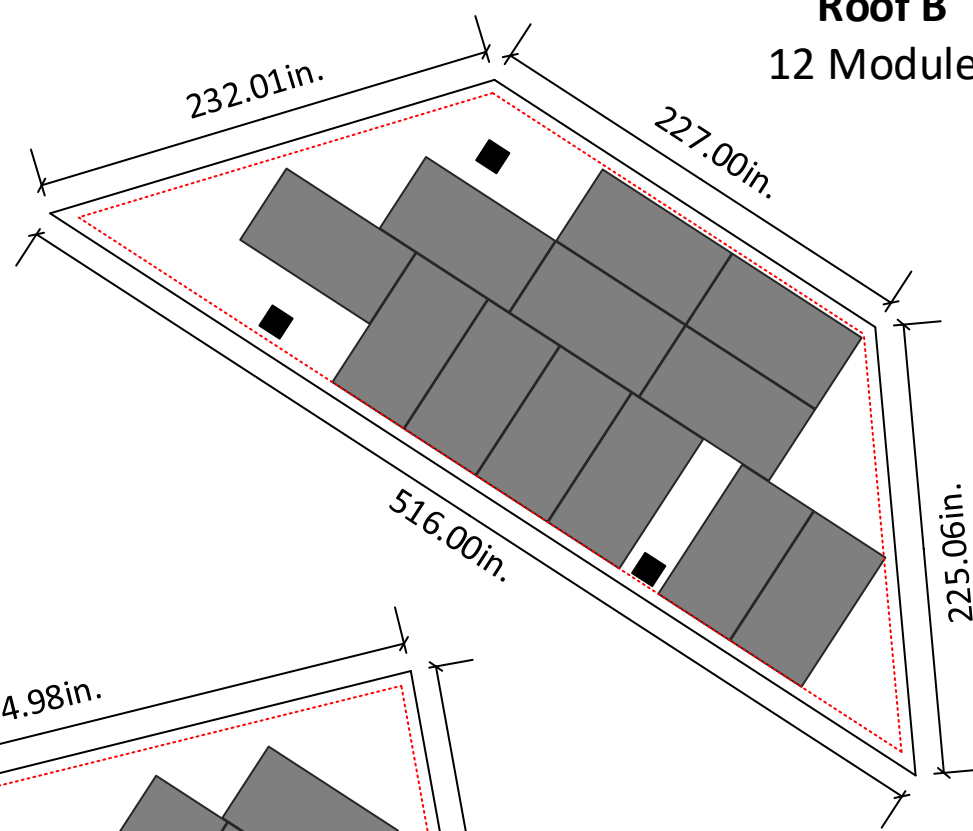

**Roof B**  
12 Modules

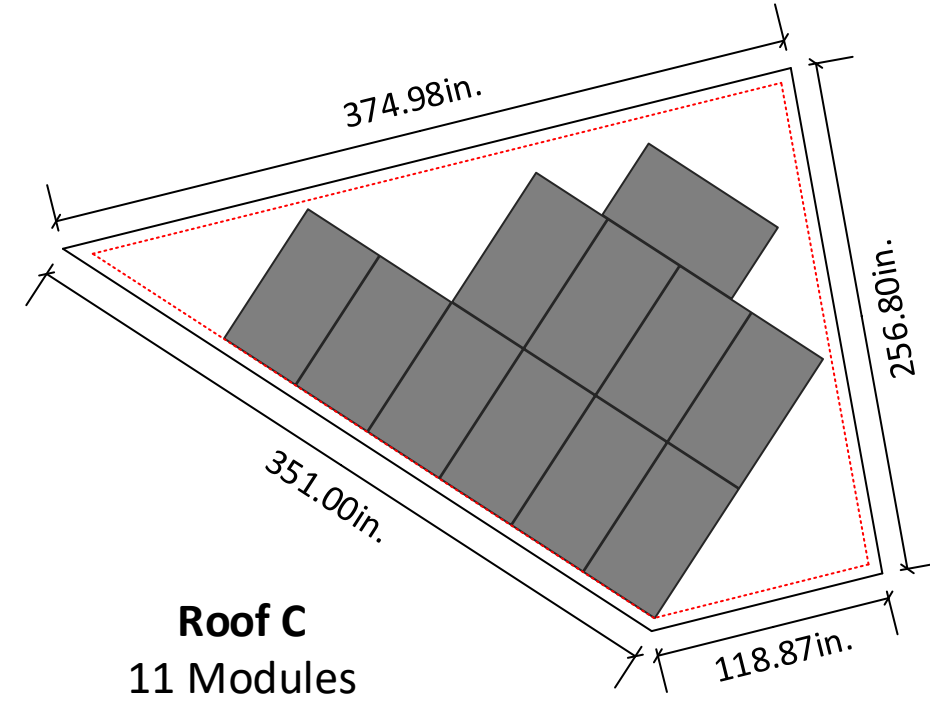

**Roof C**  
11 Modules

6in setback from sides of the roof

SITE LAYOUT  
 SCALE: 1/8" - 1'

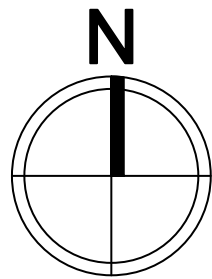

**Customer Information:**

**Cory Kolek**  
 29 Dekalb Court  
 Fuquay-Varina NC 27526

**Customer Signature:**

**Sheet Name:**

Site Layout

**JOB NUMBER:**

23-125-CK

**Date:**

04/05/2023

**Revision:**

A

**Sheet Size:**

ANSI C  
 17" X 22"

**Sheet Number:**

PV2



ROOF DESCRIPTION				MODULE DIMENSIONS	STRING LAYOUT					
ROOFS	PITCH	AZIMUTH	NO. OF MODULES		ENPHASE IQ COMBINER 4					
A	34°	302°	08		Strings #	No. of Modules	Color	Strings #	No. of Modules	Color
B	34°	213°	12		String 1	12	Blue			Green
C	19°	213°	11		String 2	11	Orange			Purple
					String 3	08	Brown			Light Blue

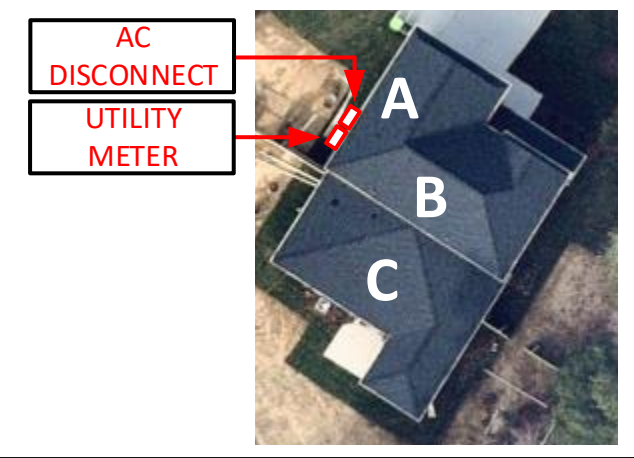

**SYSTEM DETAILS**

NUMBER OF PANELS : 31  
 PANELS MODEL : SOLARIA POWERXT 430R-PL  
 DC SIZE : 13.33 kW  
 AC SIZE : 8.99 kVA

5112 Departure Drive,  
 Raleigh NC 27616  
 O: 919.948.6474  
 E: info@8msolar.com

**Roof A**  
08 Modules

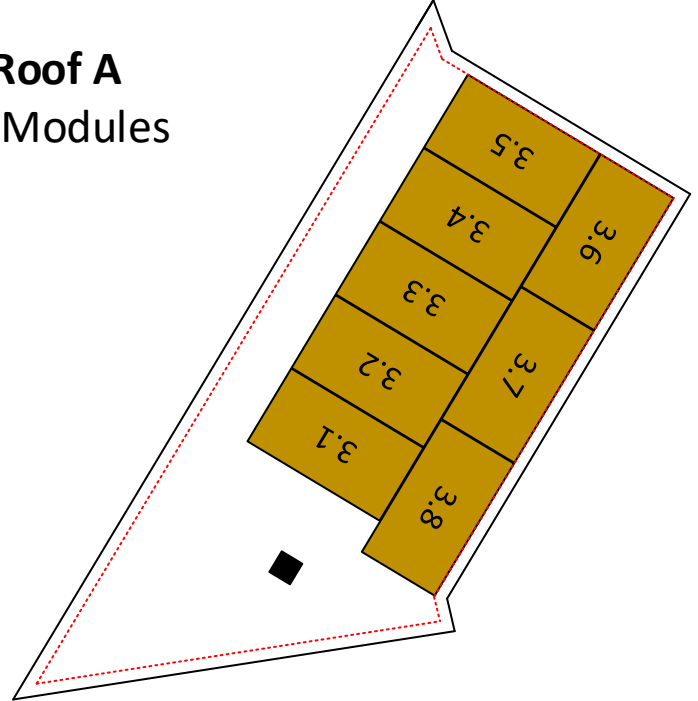

**Roof B**  
12 Modules

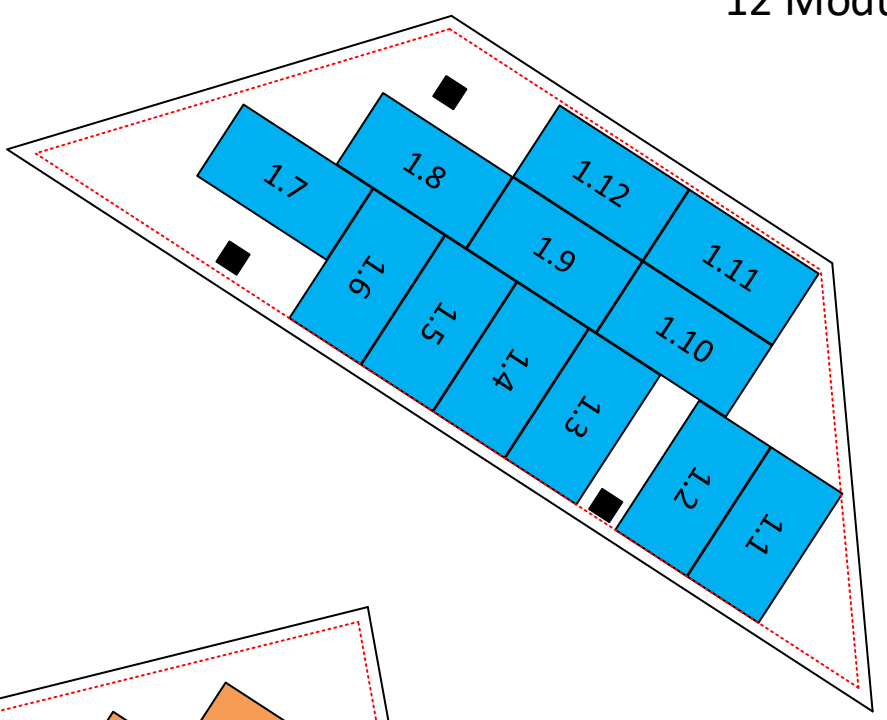

**Roof C**  
11 Modules

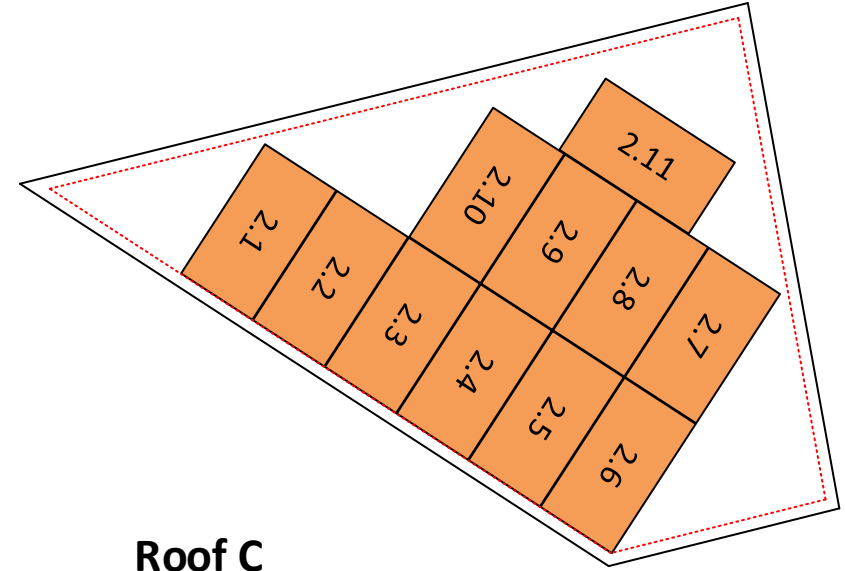

6in setback from sides of the roof

STRING MAPPING  
SCALE: 1/8" - 1'

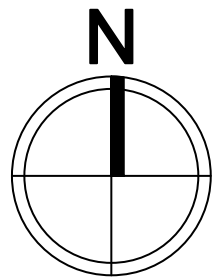

**Customer Information:**

**Cory Kolek**  
 29 Dekalb Court  
 Fuquay-Varina NC 27526

**Customer Signature:**

**Sheet Name:**

String Mapping

**JOB NUMBER:**

23-125-CK

**Date:**

04/05/2023

**Revision:**

A

**Sheet Size:**

ANSI C  
17" X 22"

**Sheet Number:**

PV3



**STRING CALCULATION**

String #	No of Modules	Estimated Power	I <sub>max</sub>	V <sub>oc</sub>	V <sub>mpp</sub>	V <sub>rise</sub> (<= 2%)
1	12	5,160 W	18.15 AC	<30	240V AC	1.18+0.63 = <b>1.81</b>
2	11	4,730 W	16.63 AC	<30	240V AC	0.96+0.35 = <b>1.31</b>
3	08	3,440 W	12.1 AC	<30	240V AC	0.62+0.42 = <b>1.04</b>

**NEC Code and UL Standard References**

Rapid Shut Down	NEC 690.12 (A-D), UL1741	Grounding	NEC Article 250.30(A)
Disconnecting Means	NEC 690.13	Conduit Fill	NEC Table C.9, 310.15(B)(3)(a)
Feeder Sizing	NEC Table 310, 15(B)(16, 17)	Interconnection	NEC 705.12
Over current Protection	NEC 690.9		



5112 Departure Drive,  
Raleigh NC 27616  
O: 919.948.6474  
E: info@8msolar.com

31 X SOLARIA POWERXT 430R-PL  
430W  
ENPHASE IQ8PLUS-72-2-US MICROINVERTERS  
290VA  
RAPID SHUTDOWN EQUIPPED

**Note:** Power Drop Required: Service Side Work

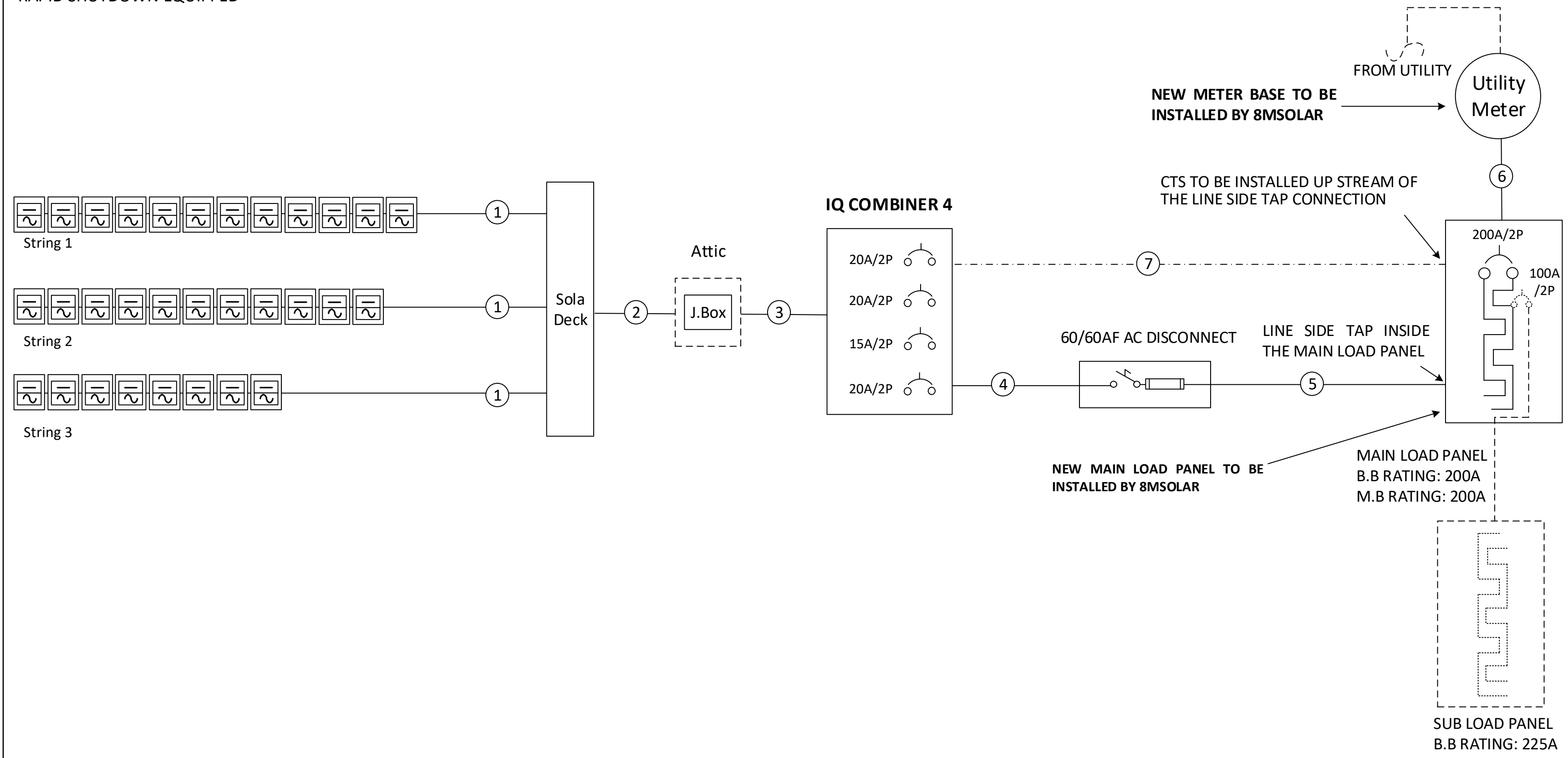

**Customer Information:**

**Cory Kolek**  
29 Dekalb Court  
Fuquay-Varina NC 27526

**Customer Signature:**

**Sheet Name:**

Electrical One Line Diagram

**JOB NUMBER:**

23-125-CK

**Date:**

04/05/2023

**Revision:**

A

**Sheet Size:**

ANSI C  
17" X 22"

**Sheet Number:**

PV4

- System Size: 13,330W DC
- (31) SOLARIA POWERXT 430R-PL
- (31) ENPHASE IQ8PLUS-72-2-US MICROINVERTERS
- Inverter Output: 1.21A max @ 240 VAC (each microinverter)
- 290 VA AC output max (each micro inverter)
- 8.99 kVA AC output max

- Grounding will be done via Pegasus grounding lugs and mid-clamps to ensure the rail and panels are continuously grounded.
- Rapid Shutdown is included in the Micro Inverters, refer to Micro Inverter attached datasheets.
- The load center / disconnect will be visible, lockable accessible to utility linesmen and will be properly labelled as per NEC requirements. It will be located on the exterior wall of the building, next to the utility meter.

Sr.No	#Wire	Conduit Size	Ground Wire	Amperage
1	1 x #12 Q Cable		#10 Bare CU	20
2	3 x #10 MC Cable			20
3	6 x #10 THHN Cu	3/4" EMT	#10 Green	20
4	3 x #6 THHN Cu	1" EMT	#8 Green	60
5	3 x #6 THHN Cu	1" EMT		60
6	3 x #3/0 THHN Cu	2" PVC		200
7	Lead Wire 18AWG, PVC Extruded	3/4" EMT		



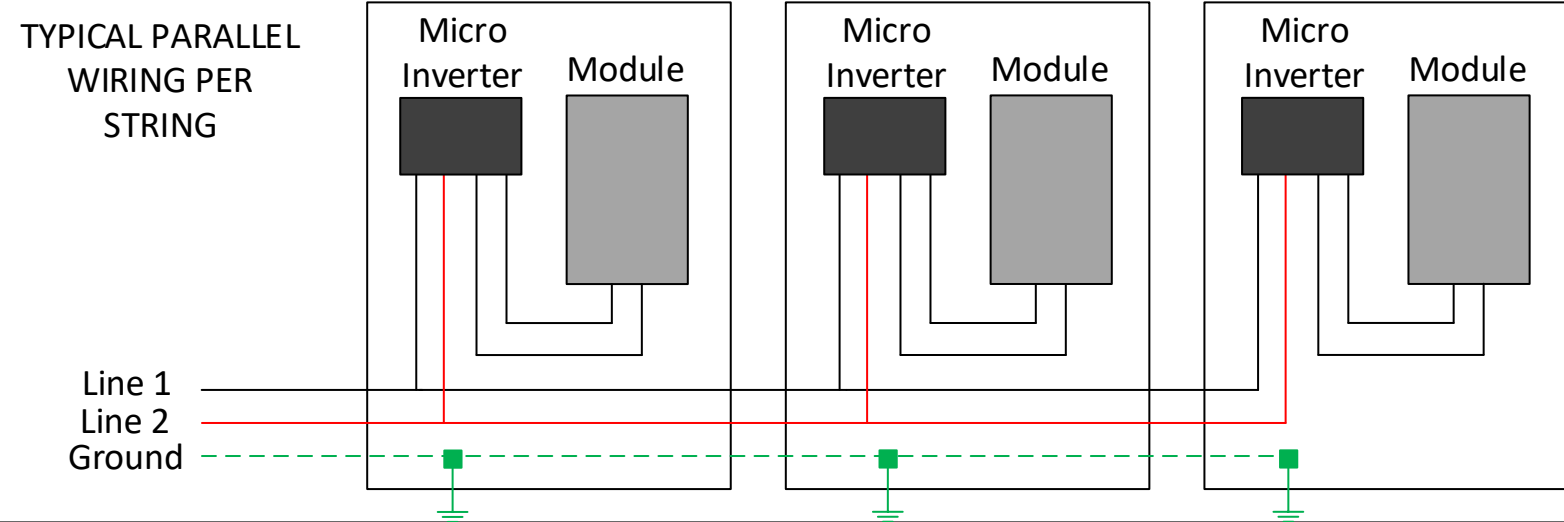

Line 1	—
Line 2	—
Neutral	—
Ground	—

**Note:** Line 1 from all strings will be passed from the Production CT.

**Note:** Neutral and Ground bar should be bonded in main load panel

**Note:** The arrow on Production and Consumption CTs must point towards the loads and away from the source.

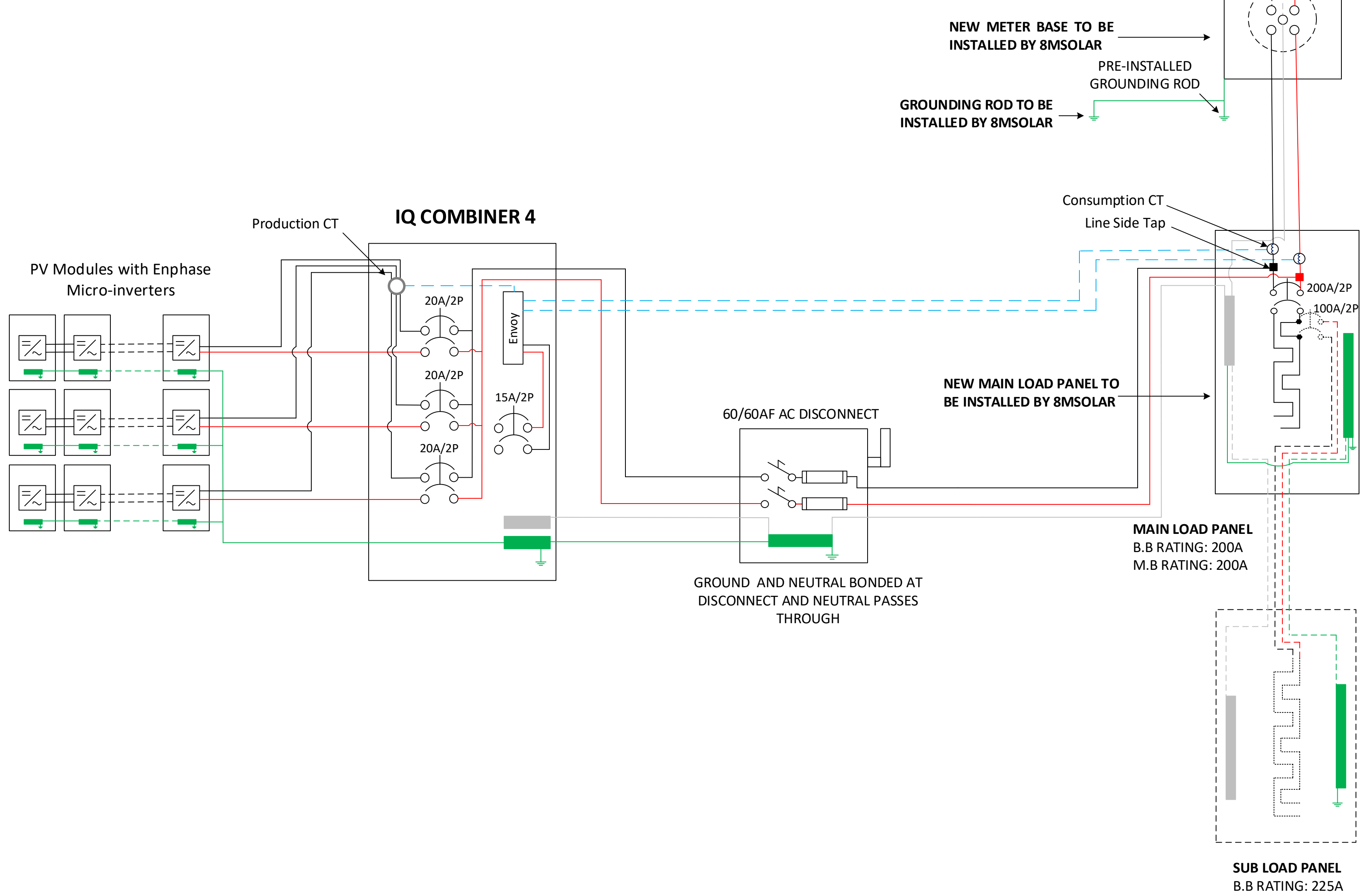

**NOTE:** Connect both grounding rods in a series connections with a bare copper keeping the minimum distance of 6ft between them.



5112 Departure Drive,  
Raleigh NC 27616  
O: 919.948.6474  
E: info@8msolar.com

**Customer Information:**

**Cory Kolek**  
29 Dekalb Court  
Fuquay-Varina NC 27526

**Customer Signature:**

**Sheet Name:**

Detailed Electrical Diagram

**JOB NUMBER:**

23-125-CK

**Date:**

04/05/2023

**Revision:**

A

**Sheet Size:**

ANSI C  
17" X 22"

**Sheet Number:**

PV5



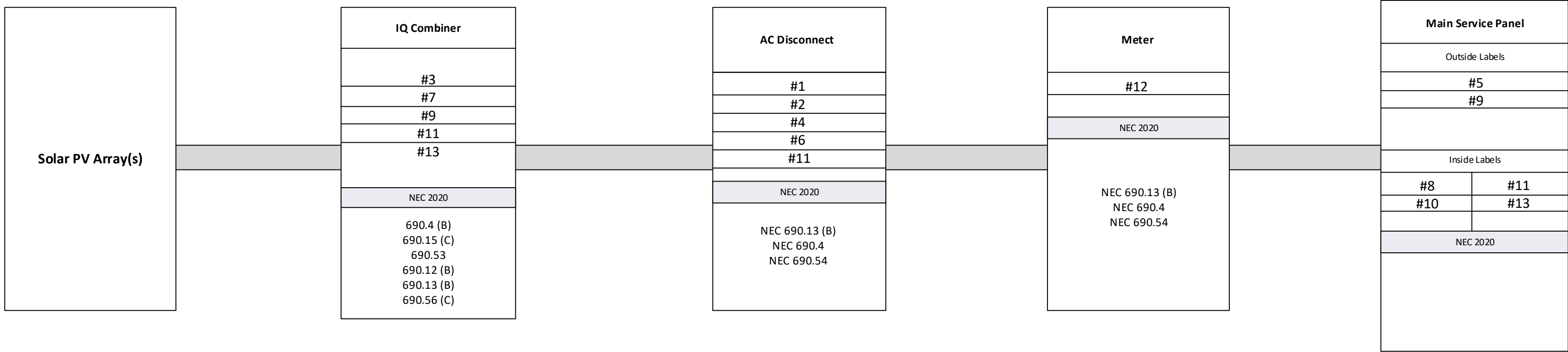

5112 Departure Drive,  
Raleigh NC 27616  
O: 919.948.6474  
E: info@8msolar.com

## LABELING AND WARNING SIGNS: NEC 2020

**A. PURPOSE**  
PROVIDE EMERGENCY RESPONDERS WITH APPROPRIATE WARNING AND GUIDANCE WITH RESPECT TO ISOLATING THE SOLAR ELECTRIC SYSTEM. THIS CAN FACILITATE IDENTIFYING ENERGIZED ELECTRICAL LINES THAT CONNECT THE SOLAR PANELS TO THE INVERTER, AS SHOULD NOT BE CUT WHEN VENTING FOR SMOKE REMOVAL.

**B. MAIN SERVICE DISCONNECT:**  
1. RESIDENTIAL BUILDINGS- THE MARKING MAY BE PLACED WITHIN THE MAIN SERVICE DISCONNECT. THE MARKING SHALL BE PLACED ON THE OUTSIDE COVER IF THE MAIN SERVICE DISCONNECT IS OPERABLE WITH THE SERVICE PANEL CLOSED.

2. COMMERCIAL BUILDINGS- THE MARKINGS SHALL BE PLACED ADJACENT TO THE MAIN SERVICE DISCONNECT CLEARLY VISIBLE FROM THE LOCATION WHERE THE LEVER IS OPERATED

3. MARKINGS, VERBIAGE, FORMAT AND TYPE OF MATERIAL

- a. VERBIAGE: CAUTION; SOLAR ELECTRIC SYSTEM CONNECTED
- b. FORMAT:

- (1) WHITE LETTERING ON A RED BACKGROUND
- (2) MINIMUM 3/8 INCH LETTER HEIGHT
- (3) ALL LETTERS SHALL BE CAPITALIZED
- (4) ARIAL OR SIMILAR FONT, NON-BOLD

c. MATERIAL:

- (1) REFLECTIVE, WEATHER RESISTANT MATERIAL SUITABLE FOR THE ENVIRONMENT (USE UL-969) AS STANDARD FOR WEATHER RATING); DURABLE ADHESIVE MATERIALS MEET THIS REQUIREMENT.

**C. MARKING REQUIREMENTS ON CONDUIT, RACEWAYS, ENCLOSURES, CABLE ASSEMBLIES, COMBINERS AND JUNCTION BOXES;**

1. MARKING: PLACEMENT, VERBIAGE, FORMAT AND TYPE OF MATERIAL.

a. PLACEMENT: MARKINGS SHALL BE PLACED EVERY 10 (TEN) FEET ON ALL INTERIOR AND EXTERIOR DC CONDUITS, RACEWAYS, ENCLOSURES AND CABLE ASSEMBLIES, AT TURNS ABOVE AND/OR BELOW PENETRATIONS, ALL COMBINERS AND JUNCTION BOXES.

b. VERBIAGE: CAUTION SOLAR CIRCUIT

c. THE FORMAT AND TYPE OF MATERIAL SHALL ADHERE TO SECTION B-3.B & C ABOVE

**D. INVERTERS ARE NOT REQUIRED TO HAVE CAUTION MARKINGS**

**#1** PHOTOVOLTAIC  
AC DISCONNECT

**#2** RAPID SHUTDOWN SWITCH FOR SOLAR PV SYSTEM

**#3** PHOTOVOLTAIC POWER SOURCE  
OPERATING AC VOLTAGE **240** V  
MAXIMUM OPERATING AC OUTPUT CURRENT **46.88** A

**#4** AC DISCONNECT PHOTOVOLTAIC SYSTEM POWER SOURCE  
RATED AC OUTPUT CURRENT **46.88** AMPS  
NOMINAL OPERATING AC VOLTAGE **240** VOLTS

**#5** SOLAR AC DISCONNECT LOCATED AT NORTH-WEST SIDE WALL OF THE HOUSE BESIDE THE MAIN LOAD PANEL

**#6** SERVICE DISCONNECT LOCATED INSIDE THE MAIN LOAD PANEL

**#7** PHOTOVOLTAIC SYSTEM COMBINER PANEL DO NOT ADD LOADS

**#8** **WARNING**  
THIS EQUIPMENT FED BY MULTIPLE SOURCES. TOTAL RATING OF ALL OVERCURRENT DEVICES, EXCLUDING MAIN SUPPLY OVERCURRENT DEVICE, SHALL NOT EXCEED AMPACITY OF BUSBAR

**#9** **WARNING**  
DUAL POWER SUPPLY SOURCES: UTILITY GRID AND PV SOLAR ELECTRIC SYSTEM

**#10** **WARNING**  
TURN OFF PHOTOVOLTAIC AC DISCONNECT PRIOR TO WORKING INSIDE PANEL

**#11** **WARNING**  
ELECTRIC SHOCK HAZARD TERMINAL ON THE LINE AND LOAD SIDES MAY BE ENERGIZED IN THE OPEN POSITION

**#12** **WARNING**  
THIS SERVICE METER IS ALSO SERVED BY A PHOTOVOLTAIC SYSTEM

**#13** SOLAR PV SYSTEM EQUIPPED WITH RAPID SHUTDOWN  
TURN RAPID SHUTDOWN SWITCH TO THE "OFF" POSITION TO SHUT DOWN PV SYSTEM AND REDUCE SHOCK HAZARD IN THE ARRAY

### Customer Information:

**Cory Kolek**  
29 Dekalb Court  
Fuquay-Varina NC 27526

### Customer Signature:

### Sheet Name:

PV Labels

### JOB NUMBER:

23-125-CK

### Date:

04/05/2023

### Revision:

A

### Sheet Size:

ANSI C  
17" X 22"

### Sheet Number:

PV6



ROOF DESCRIPTION			
ROOFS	PITCH	AZIMUTH	NO. OF MODULES
A	34°	302°	08
B	34°	213°	12
C	19°	213°	11

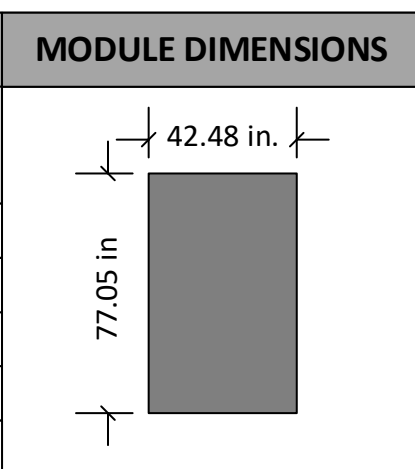

Rails and Splices : PSR-B84 (BLACK)      Roof Attachment : Pegasus Comp Mount

Rafter Spacing : 24 in

Attachment Span: 4ft

There is one layer of shingles  
Roofing material is asphalt shingles

The roof is located in 135mph wind zone

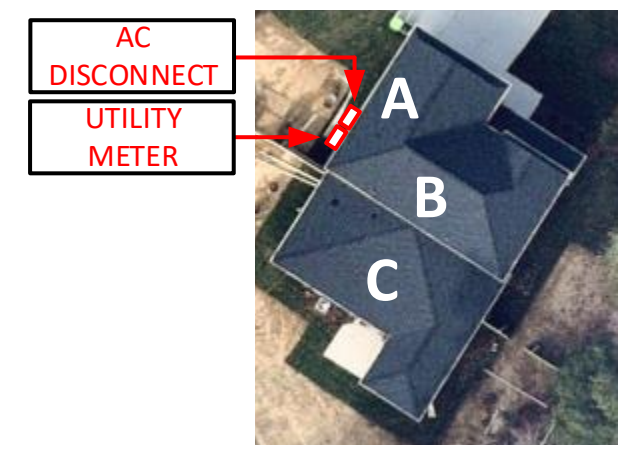

5112 Departure Drive,  
Raleigh NC 27616  
O: 919.948.6474  
E: info@8msolar.com

**Roof A**  
08 Modules

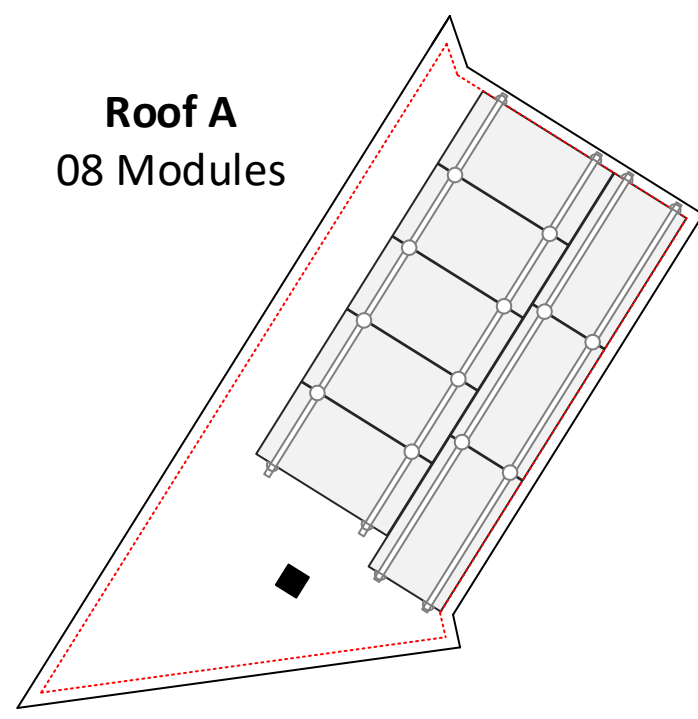

**Roof B**  
12 Modules

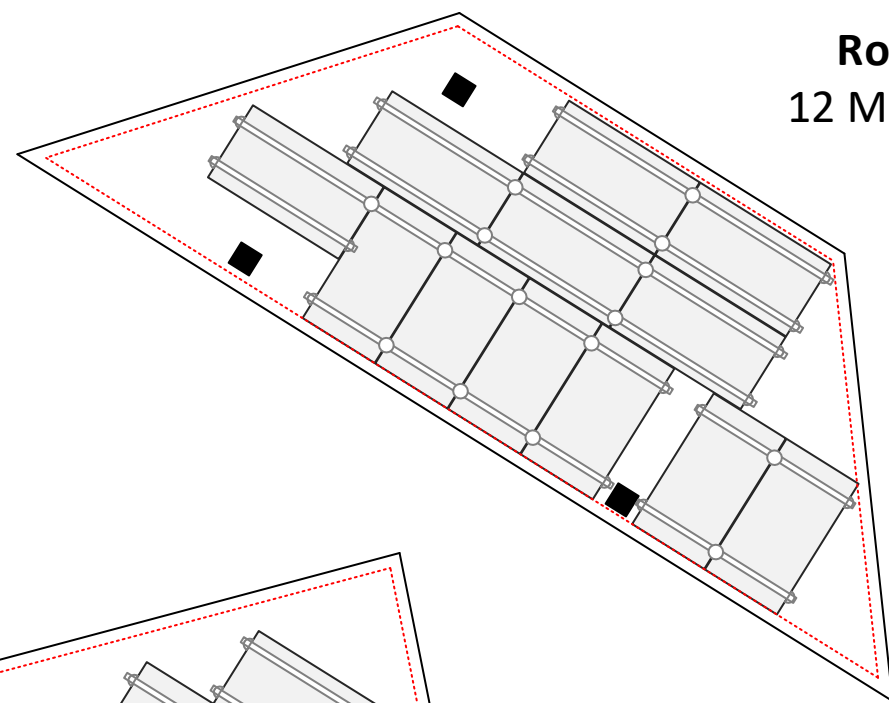

**Roof C**  
11 Modules

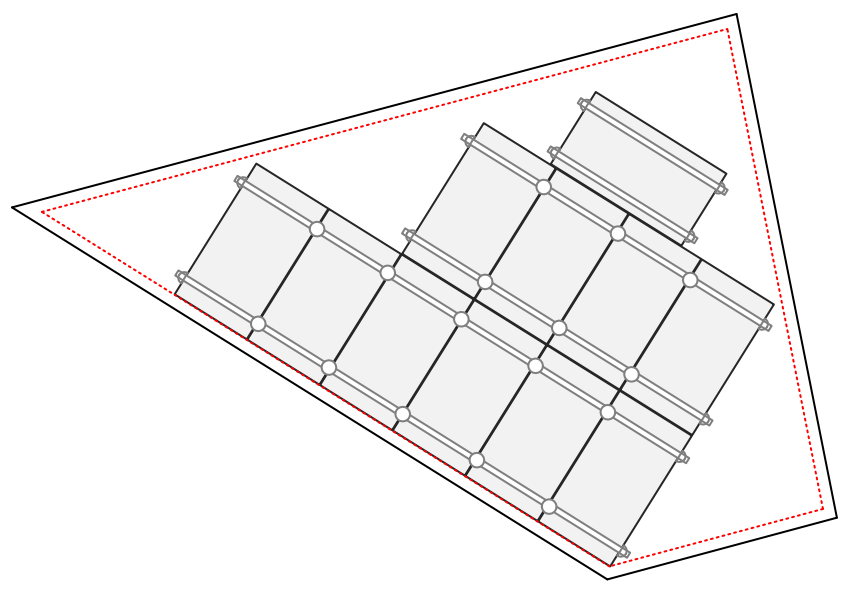

6in setback from  
sides of the roof

PV LABELS		
Sr No	Code	Qty
01	03-302	01
02	02-316	01
03	03-390	01
04	03-306	01
05	8M-001	01
06	8M-002	01
07	03-355	01
08	05-108	01
09	05-211	02
10	05-372	01
11	05-215	03
12	07-359	01
13	07-111	02

- RAILS AND MOUNTING SYSTEM**
- 50 x PSR-B84: Pegasus Rail, Black, 84" (7 Feet)
  - 30 x PSR-SPL: Pegasus - Bonded, Structural Splice
  - 42 x PSR-MCB: Pegasus - Multiclamp, Mid/End, 30 to 40 mm, Black
  - 40 x PSR-HEC: Pegasus - Hidden End Clamp
  - 31 x PSR-MLP: Pegasus - MLPE Mount
  - 14 x PSR-LUG: Pegasus - Grounding Lug
  - 47 x PSR-WMC: Pegasus - Wire Management Clip
  - 06 x PSR-CBG: Pegasus - Cable Grip
  - 40 x PSR-CAP: Pegasus - End Cap
  - 78 x PSCR-UBBDT: Pegasus Comp Mount - Open Slot, Black L Foot, Black Flashing, Dovetail 3/8" T-Bolt
  - 62 x Heyco Wire Clips

- SOLAR MODULES**
- 31 x SOLARIA POWERXT 430R-PL

- INVERTER & SUPPORTING ITEMS**
- 31 x Enphase IQ8PLUS-72-2-US micro inverter
  - 01 x X-IQ-AM1-240-4 IQ Combiner 4

- ENPHASE CABLES AND ACCESSORIES**
- 25 x Q-12-10-240: Q Cable
  - 12 x Q-12-20-200: Q Cable
  - 01 x Q-12-RAW-300:Q Cable, 12 AWG (40ft)
  - 09 x Q-CONN-10M Male Field-wireable connector
  - 09 x Q-CONN-10F Female Field-wireable connector
  - 03 x Q-TERM-10: Terminator Cap
  - 04 x Q-SEAL-10: Female Sealing Cap
  - 01 x Q-CLIP-100: Q Cable rail mount cable management clip (Pack of 100)
  - 01 x Q-DISC-10: Disconnect tool

- ELECTRICAL ITEMS**
- 03 x Eaton BR220B with hold down kit support (Circuit breaker, 2 pole, 20A)
  - 01 x UAT417-XGF: 200A Meter Base
  - 01 x QOM2200VH: 200A Main breaker, 2 pole
  - 01 x QO112L200GRB: Square D 'QO' 200 Amp 12-Space 12-Circuit Outdoor Main Lug Load Center with Ground Bar
  - 02 x IPCS 4002: Line/Load Side Hot Taps (#4/0 main - #2-10 tap) Medium types
  - 01 x D222NRB: 250volt/60amp/2pole fusible disconnect (NEMA 3R)
  - 02 x SQUARE D FRNR60: 250volt/60amp fuses
  - 01 x EZSLR JB-1.2: SolaDeck Box
  - 05 x FM-CM-001-B: Roof Flashing Conduit Supports

**Customer Information:**

**Cory Kolek**  
29 Dekalb Court  
Fuquay-Varina NC 27526

**Customer Signature:**

**Sheet Name:**

Bill of Material

**JOB NUMBER:**

23-125-CK

**Date:**

04/05/2023

**Revision:**

A

**Sheet Size:**

ANSI C  
17" X 22"

**Sheet Number:**

PV7

**BILL OF MATERIAL**  
SCALE: 1/8" - 1'

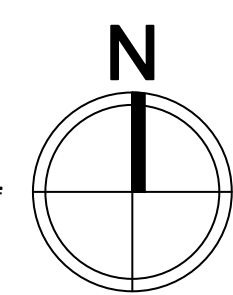

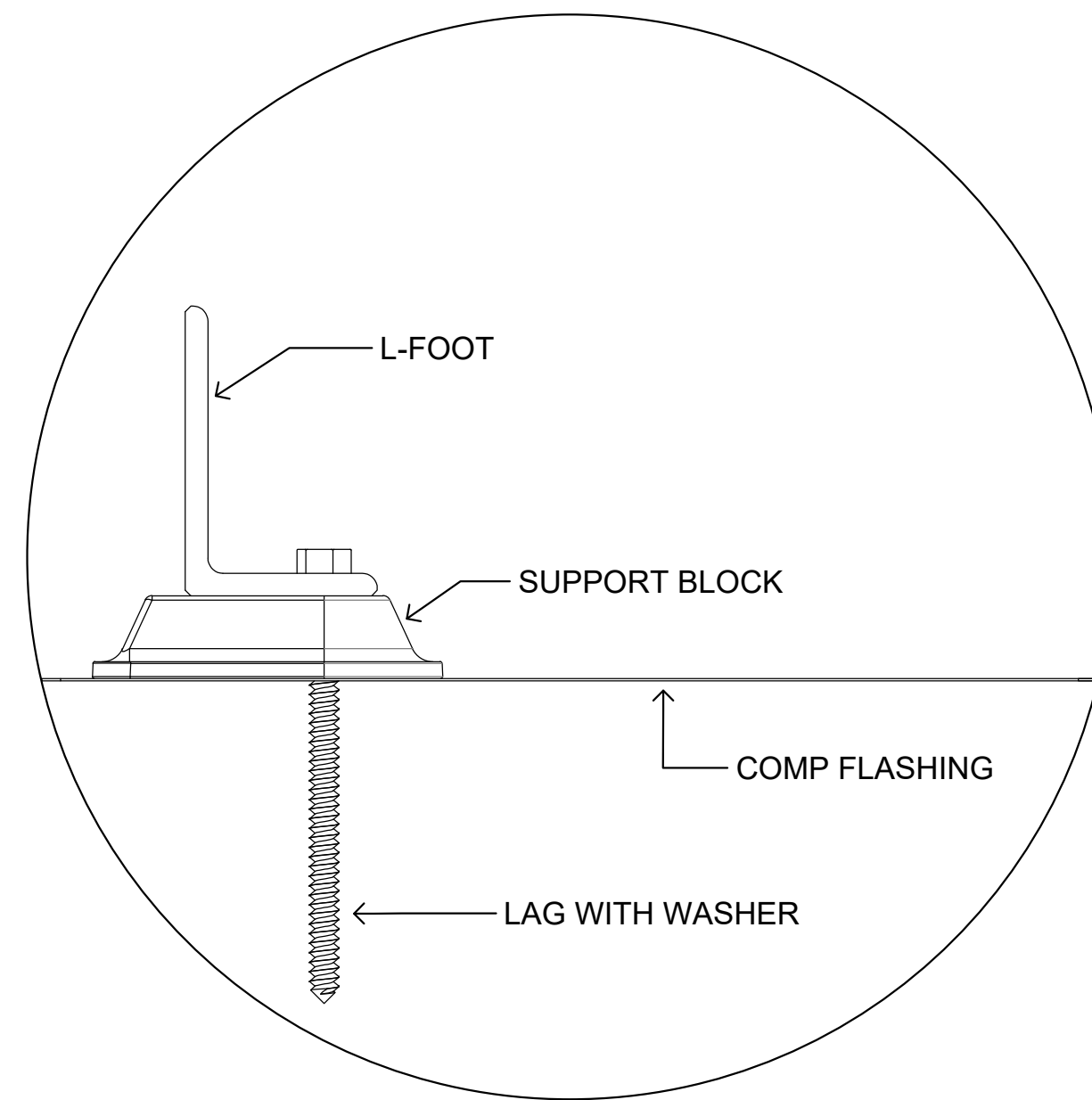
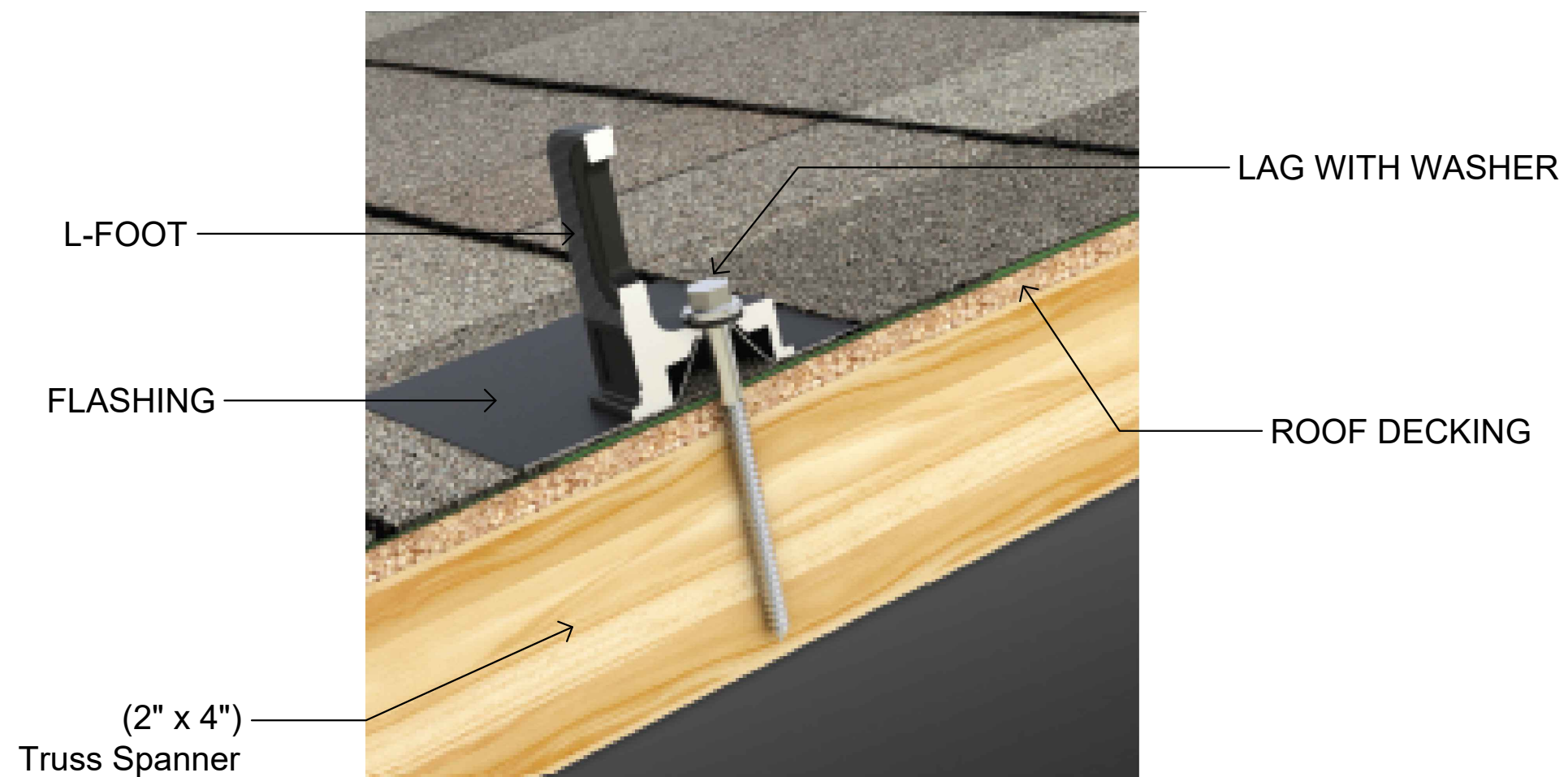

5112 Departure Drive,  
Raleigh NC 27616  
O: 919.948.6474  
E: info@8msolar.com

**Customer Information:**

**Cory Kolek**

29 Dekalb Court  
Fuquay-Varina NC 27526

**Customer Signature:**

**Sheet Name:**

Attachment Details

**JOB NUMBER:**

23-125-CK

**Date:**

04/05/2023

**Revision:**

A

**Sheet Size:**

ANSI C  
17" X 22"

**Sheet Number:**

PV8

Multi-Clamp	Hidden End Clamp	MLPE Mount	Dovetail T-Bolt	Ground Lug	Cable Grip
Torque Value 100 in-lbs.	Torque Value 135 in-lbs.	Torque Value 135 in-lbs.	Torque Value 300 in-lbs.	Torque Value 135 in-lbs.	Torque Value 135 in-lbs.

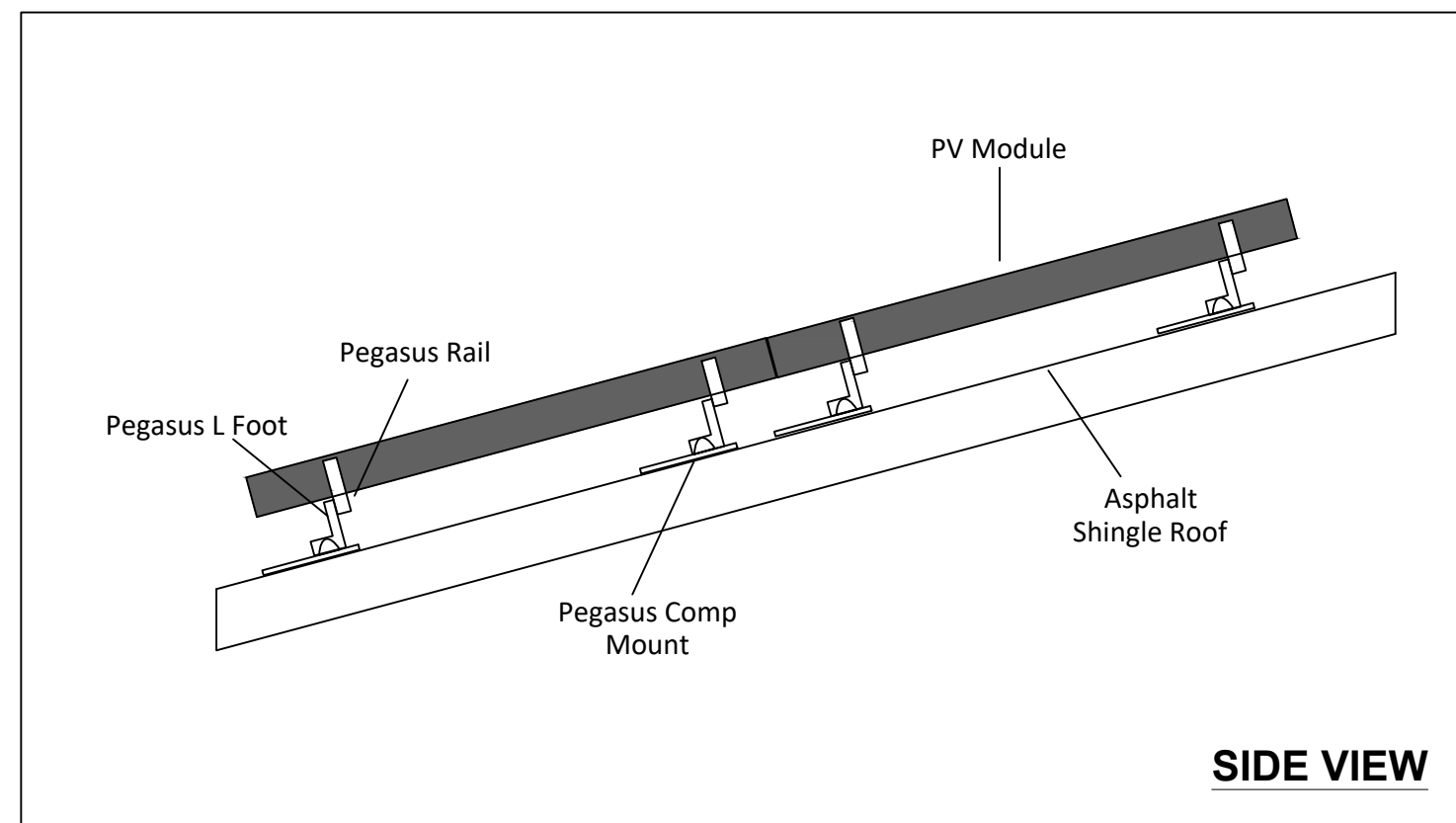



### Solaria PowerXT 430R-PL

Achieving over 20% efficiency, Solaria PowerXT solar panels are one of the highest power panels in the residential and commercial solar market. Compared to conventional panels, Solaria PowerXT panels have fewer gaps between the solar cells; this leads to higher power and superior aesthetics. Solaria PowerXT Pure Black™ panels are manufactured with black backsheets and frames, enhancing a home or building's architectural beauty.



#### High Efficiency, High Power

Solaria PowerXT panels achieve up to 20.4% efficiency. Solaria PowerXT panels are one of the highest power panels available.



#### High Quality and Reliability

Solder-less cell interconnections are highly reliable and designed to far exceed the industry leading 30 year warranty.



#### Improved Aesthetics

Compared to conventional panels, Solaria PowerXT panels have a more uniform appearance and superior aesthetics.



#### Lower System Costs

Solaria PowerXT panels produce more power per square meter area. This reduces installation costs due to fewer balance of system components.



#### Improved Shading Tolerance

Sub-strings are interconnected in parallel, within each of the four panel quadrants, which dramatically lowers the shading losses and boosts energy yield.



#### PID Resistant

Solaria PowerXT panels are PID resistant. This insures stable and predictable energy production over time.



### About Solaria

Established in 2000, The Solaria Corporation has created one of the industry's most respected IP portfolios, with over 250 issued and pending patents in PV solar cell and module technology. Headquartered in California, Solaria has developed a technology platform that unlocks the potential of solar energy.



### Performance at STC (1000W/m<sup>2</sup>, 25° C, AM 1.5)

Solaria PowerXT		420R-PL	430R-PL
Max Power (P <sub>max</sub> )	[W]	420	430
Efficiency	[%]	19.9	20.4
Open Circuit Voltage (V <sub>oc</sub> )	[V]	45.7	45.7
Short Circuit Current (I <sub>sc</sub> )	[A]	11.60	11.87
Max Power Voltage (V <sub>mp</sub> )	[V]	37.9	37.9
Max Power Current (I <sub>mp</sub> )	[A]	11.09	11.35
Power Tolerance	[%]	-0/+3	-0/+3

### Performance at NOCT (800W/m<sup>2</sup>, 20°C Amb, Wind 1 m/s, AM 1.5)

Max Power (P <sub>max</sub> )	[W]	310	317
Open Circuit Voltage (V <sub>oc</sub> )	[V]	43.0	43.0
Short Circuit Current (I <sub>sc</sub> )	[A]	9.36	9.57
Max Power Voltage (V <sub>mp</sub> )	[V]	34.6	34.6
Max Power Current (I <sub>mp</sub> )	[A]	8.95	9.15

### Temperature Characteristics

NOCT	[°C]	45 +/-2
Temp. Coeff. of P <sub>max</sub>	[% / °C]	-0.39
Temp. Coeff. of V <sub>oc</sub>	[% / °C]	-0.29
Temp. Coeff. of I <sub>sc</sub>	[% / °C]	+0.04

### Design Parameters

Operating temperature	[°C]	-40 to +85
Max System Voltage	[V]	1000
Max Fuse Rating	[A]	20
Bypass Diodes	[#]	4

### IV Curves vs. Irradiance (430W Panel)

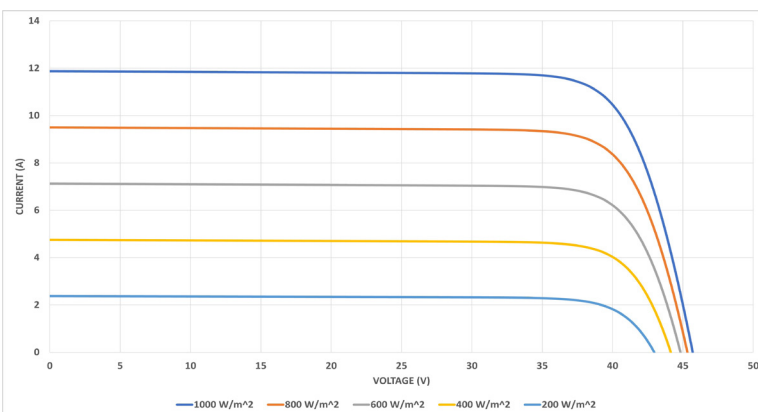

### Comprehensive 30-Year Warranty

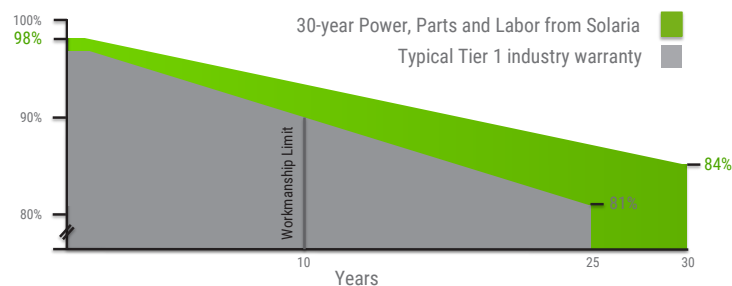

### Mechanical Characteristics

Cell Type	Monocrystalline Silicon
Dimensions (L x W x H)	77" x 42.5" x 1.38" 1957mm x 1079mm x 35mm
Weight	21.7 kg / 47.8 lbs
Glass Type / Thickness	AR Coated, Tempered / 2.8mm
Frame Type	Black Anodized Aluminum
Cable Type / Length	12 AWG PV Wire (UL) / 1200mm
Connector Type	MC4
Junction Box	IP68 / 4 diodes
Front Load	5400 Pa / 113 psf*
Rear Load	3600 Pa / 75 psf*

\* Refer to Solaria Installation Manual for details

### Certifications / Warranty

Certifications	UL 61730 / IEC 61215 / IEC 61730 CEC & FSEC Listed
----------------	---

Fire Type (UL 1703)	1
Warranty	30 years*

\* Warranty details at [www.solaria.com](http://www.solaria.com)

### Packaging

Stacking Method	Horizontal / Palletized
Panels/ Pallet	29
Pallet Dims (L x W x H)	78.7" x 45" x 50.1" 2000mm x 1143mm x 1273mm
Pallet Weight	696 kg / 1533 lbs
Pallets / 40-ft Container	22
Panels / 40-ft Container	638

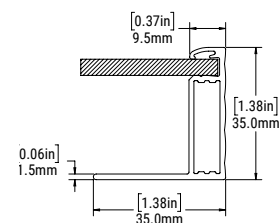
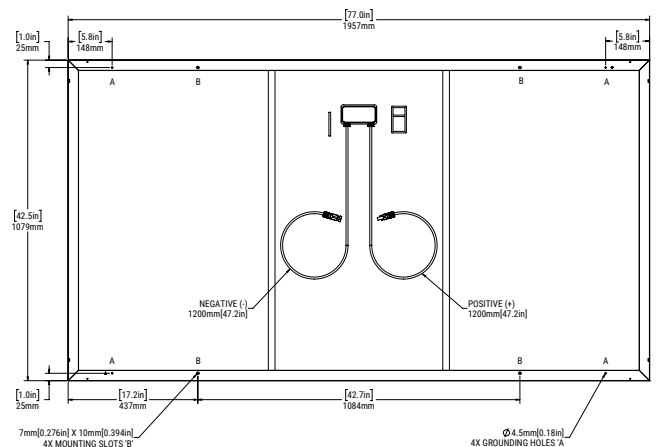



# IQ8 Series Microinverters

Our newest IQ8 Microinverters are the industry’s first microgrid-forming, software-defined microinverters with split-phase power conversion capability to convert DC power to AC power efficiently. The brain of the semiconductor-based microinverter is our proprietary application-specific integrated circuit (ASIC) which enables the microinverter to operate in grid-tied or off-grid modes. This chip is built in advanced 55nm technology with high speed digital logic and has super-fast response times to changing loads and grid events, alleviating constraints on battery sizing for home energy systems.



Part of the Enphase Energy System, IQ8 Series Microinverters integrate with the Enphase IQ Battery, Enphase IQ Gateway, and the Enphase App monitoring and analysis software.



IQ8 Series Microinverters redefine reliability standards with more than one million cumulative hours of power-on testing, enabling an industry-leading limited warranty of up to 25 years.



Connect PV modules quickly and easily to IQ8 Series Microinverters using the included Q-DCC-2 adapter cable with plug-n-play MC4 connectors.



IQ8 Series Microinverters are UL Listed as PV Rapid Shut Down Equipment and conform with various regulations, when installed according to manufacturer’s instructions.

## Easy to install

- Lightweight and compact with plug-n-play connectors
- Power Line Communication (PLC) between components
- Faster installation with simple two-wire cabling

## High productivity and reliability

- Produce power even when the grid is down\*
- More than one million cumulative hours of testing
- Class II double-insulated enclosure
- Optimized for the latest high-powered PV modules

## Microgrid-forming

- Complies with the latest advanced grid support\*\*
- Remote automatic updates for the latest grid requirements
- Configurable to support a wide range of grid profiles
- Meets CA Rule 21 (UL 1741-SA) requirements

\* Only when installed with IQ System Controller 2, meets UL 1741. IQ8H-208V operates only in grid-tied mode.

\*\* IQ8 Series Microinverters supports split phase, 240V. IQ8H-208 supports split phase, 208V only.

# IQ8 Series Microinverters

INPUT DATA (DC)		IQ8-60-2-US	IQ8PLUS-72-2-US	IQ8M-72-2-US	IQ8A-72-2-US	IQ8H-240-72-2-US	IQ8H-208-72-2-US <sup>1</sup>
Commonly used module pairings <sup>2</sup>	W	235 – 350	235 – 440	260 – 460	295 – 500	320 – 540+	295 – 500+
Module compatibility		60-cell/120 half-cell	60-cell/120 half-cell, 66-cell/132 half-cell and 72-cell/144 half-cell				
MPPT voltage range	V	27 – 37	29 – 45	33 – 45	36 – 45	38 – 45	38 – 45
Operating range	V	25 – 48	25 – 58				
Min/max start voltage	V	30 / 48	30 / 58				
Max input DC voltage	V	50	60				
Max DC current <sup>3</sup> [module Isc]	A	15					
Overtoltage class DC port		II					
DC port backfeed current	mA	0					
PV array configuration		1x1 Ungrounded array; No additional DC side protection required; AC side protection requires max 20A per branch circuit					
OUTPUT DATA (AC)		IQ8-60-2-US	IQ8PLUS-72-2-US	IQ8M-72-2-US	IQ8A-72-2-US	IQ8H-240-72-2-US	IQ8H-208-72-2-US <sup>1</sup>
Peak output power	VA	245	300	330	366	384	366
Max continuous output power	VA	240	290	325	349	380	360
Nominal (L-L) voltage/range <sup>4</sup>	V	240 / 211 – 264					208 / 183 – 250
Max continuous output current	A	1.0	1.21	1.35	1.45	1.58	1.73
Nominal frequency	Hz	60					
Extended frequency range	Hz	50 – 68					
AC short circuit fault current over 3 cycles	Arms	2					4.4
Max units per 20 A (L-L) branch circuit <sup>5</sup>		16	13	11	11	10	9
Total harmonic distortion		<5%					
Overtoltage class AC port		III					
AC port backfeed current	mA	30					
Power factor setting		1.0					
Grid-tied power factor (adjustable)		0.85 leading – 0.85 lagging					
Peak efficiency	%	97.5	97.6	97.6	97.6	97.6	97.4
CEC weighted efficiency	%	97	97	97	97.5	97	97
Night-time power consumption	mW	60					
MECHANICAL DATA							
Ambient temperature range		-40°C to +60°C (-40°F to +140°F)					
Relative humidity range		4% to 100% (condensing)					
DC Connector type		MC4					
Dimensions (HxWxD)		212 mm (8.3") x 175 mm (6.9") x 30.2 mm (1.2")					
Weight		1.08 kg (2.38 lbs)					
Cooling		Natural convection – no fans					
Approved for wet locations		Yes					
Pollution degree		PD3					
Enclosure		Class II double-insulated, corrosion resistant polymeric enclosure					
Environ. category / UV exposure rating		NEMA Type 6 / outdoor					
COMPLIANCE							
Certifications		CA Rule 21 (UL 1741-SA), UL 62109-1, UL1741/IEEE1547, FCC Part 15 Class B, ICES-0003 Class B, CAN/CSA-C22.2 NO. 107.1-01 This product is UL Listed as PV Rapid Shut Down Equipment and conforms with NEC 2014, NEC 2017, and NEC 2020 section 690.12 and C22.1-2018 Rule 64-218 Rapid Shutdown of PV Systems, for AC and DC conductors, when installed according to manufacturer's instructions.					

(1) The IQ8H-208 variant will be operating in grid-tied mode only at 208V AC. (2) No enforced DC/AC ratio. See the compatibility calculator at <https://link.enphase.com/module-compatibility> (3) Maximum continuous input DC current is 10.6A (4) Nominal voltage range can be extended beyond nominal if required by the utility. (5) Limits may vary. Refer to local requirements to define the number of microinverters per branch in your area.

# Enphase IQ Combiner 4/4C

X-IQ-AM1-240-4  
X-IQ-AM1-240-4C



The **Enphase IQ Combiner 4/4C** with Enphase IQ Gateway and integrated LTE-M1 cell modem (included only with IQ Combiner 4C) consolidates interconnection equipment into a single enclosure and streamlines IQ microinverters and storage installations by providing a consistent, pre-wired solution for residential applications. It offers up to four 2-pole input circuits and Eaton BR series busbar assembly.

## Smart

- Includes IQ Gateway for communication and control
- Includes Enphase Mobile Connect cellular modem (CELLMODEM-M1-06-SP-05), included only with IQ Combiner 4C
- Includes solar shield to match Enphase IQ Battery aesthetics and deflect heat
- Flexible networking supports Wi-Fi, Ethernet, or cellular
- Optional AC receptacle available for PLC bridge
- Provides production metering and consumption monitoring

## Simple

- Centered mounting brackets support single stud mounting
- Supports bottom, back and side conduit entry
- Up to four 2-pole branch circuits for 240 VAC plug-in breakers (not included)
- 80A total PV or storage branch circuits

## Reliable

- Durable NRTL-certified NEMA type 3R enclosure
- Five-year limited warranty
- Two years labor reimbursement program coverage included for both the IQ Combiner SKU's
- UL listed



To learn more about Enphase offerings, visit [enphase.com](https://enphase.com)

# Enphase IQ Combiner 4/4C

## MODEL NUMBER

IQ Combiner 4 (X-IQ-AM1-240-4)	IQ Combiner 4 with Enphase IQ Gateway printed circuit board for integrated revenue grade PV production metering (ANSI C12.20 +/- 0.5%) and consumption monitoring (+/- 2.5%). Includes a silver solar shield to match the IQ Battery system and IQ System Controller 2 and to deflect heat.
IQ Combiner 4C (X-IQ-AM1-240-4C)	IQ Combiner 4C with Enphase IQ Gateway printed circuit board for integrated revenue grade PV production metering (ANSI C12.20 +/- 0.5%) and consumption monitoring (+/- 2.5%). Includes Enphase Mobile Connect cellular modem (CELLMODEM-M1-06-SP-05), a plug-and-play industrial-grade cell modem for systems up to 60 microinverters. (Available in the US, Canada, Mexico, Puerto Rico, and the US Virgin Islands, where there is adequate cellular service in the installation area.) Includes a silver solar shield to match the IQ Battery and IQ System Controller and to deflect heat.

## ACCESSORIES AND REPLACEMENT PARTS (not included, order separately)

Ensemble Communications Kit COMMS-CELLMODEM-M1-06 CELLMODEM-M1-06-SP-05 CELLMODEM-M1-06-AT-05	- Includes COMMS-KIT-01 and CELLMODEM-M1-06-SP-05 with 5-year Sprint data plan for Ensemble sites - 4G based LTE-M1 cellular modem with 5-year Sprint data plan - 4G based LTE-M1 cellular modem with 5-year AT&T data plan
Circuit Breakers BRK-10A-2-240V BRK-15A-2-240V BRK-20A-2P-240V BRK-15A-2P-240V-B BRK-20A-2P-240V-B	Supports Eaton BR210, BR215, BR220, BR230, BR240, BR250, and BR260 circuit breakers. Circuit breaker, 2 pole, 10A, Eaton BR210 Circuit breaker, 2 pole, 15A, Eaton BR215 Circuit breaker, 2 pole, 20A, Eaton BR220 Circuit breaker, 2 pole, 15A, Eaton BR215B with hold down kit support Circuit breaker, 2 pole, 20A, Eaton BR220B with hold down kit support
EPLC-01	Power line carrier (communication bridge pair), quantity - one pair
XA-SOLARSHIELD-ES	Replacement solar shield for IQ Combiner 4/4C
XA-PLUG-120-3	Accessory receptacle for Power Line Carrier in IQ Combiner 4/4C (required for EPLC-01)
XA-ENV-PCBA-3	Replacement IQ Gateway printed circuit board (PCB) for Combiner 4/4C
X-IQ-NA-HD-125A	Hold down kit for Eaton circuit breaker with screws.

## ELECTRICAL SPECIFICATIONS

Rating	Continuous duty
System voltage	120/240 VAC, 60 Hz
Eaton BR series busbar rating	125 A
Max. continuous current rating	65 A
Max. continuous current rating (input from PV/storage)	64 A
Max. fuse/circuit rating (output)	90 A
Branch circuits (solar and/or storage)	Up to four 2-pole Eaton BR series Distributed Generation (DG) breakers only (not included)
Max. total branch circuit breaker rating (input)	80A of distributed generation / 95A with IQ Gateway breaker included
Envoy breaker	10A or 15A rating GE/Siemens/Eaton included
Production metering CT	200 A solid core pre-installed and wired to IQ Gateway
Consumption monitoring CT (CT-200-SPLIT)	A pair of 200 A split core current transformers

## MECHANICAL DATA

Dimensions (WxHxD)	37.5 x 49.5 x 16.8 cm (14.75" x 19.5" x 6.63"). Height is 21.06" (53.5 cm) with mounting brackets.
Weight	7.5 kg (16.5 lbs)
Ambient temperature range	-40° C to +46° C (-40° to 115° F)
Cooling	Natural convection, plus heat shield
Enclosure environmental rating	Outdoor, NRTL-certified, NEMA type 3R, polycarbonate construction
Wire sizes	<ul style="list-style-type: none"><li>• 20 A to 50 A breaker inputs: 14 to 4 AWG copper conductors</li><li>• 60 A breaker branch input: 4 to 1/0 AWG copper conductors</li><li>• Main lug combined output: 10 to 2/0 AWG copper conductors</li><li>• Neutral and ground: 14 to 1/0 copper conductors</li></ul> Always follow local code requirements for conductor sizing.
Altitude	To 2000 meters (6,560 feet)

## INTERNET CONNECTION OPTIONS

Integrated Wi-Fi	802.11b/g/n
Cellular	CELLMODEM-M1-06-SP-05, CELLMODEM-M1-06-AT-05 (4G based LTE-M1 cellular modem). Note that an Enphase Mobile Connect cellular modem is required for all Ensemble installations.
Ethernet	Optional, 802.3, Cat5E (or Cat 6) UTP Ethernet cable (not included)

## COMPLIANCE

Compliance, IQ Combiner	UL 1741, CAN/CSA C22.2 No. 107.1, 47 CFR, Part 15, Class B, ICES 003 Production metering: ANSI C12.20 accuracy class 0.5 (PV production) Consumption metering: accuracy class 2.5
Compliance, IQ Gateway	UL 60601-1/CANCSA 22.2 No. 61010-1

To learn more about Enphase offerings, visit [enphase.com](https://enphase.com)



© 2022 Enphase Energy. All rights reserved. Enphase, the Enphase logo, IQ Combiner 4/4C, and other names are trademarks of Enphase Energy, Inc. Data subject to change. 02-14-2022

# Rapid shutdown is built-in

The 2014 edition of the National Electrical Code (NEC 2014) added new rapid shutdown requirements for PV systems installed on buildings. Enphase Microinverters fully meet rapid shutdown requirements in the new code without the need to install any additional electrical equipment.

## What's new in NEC 2014?

NEC 2014, Section 690.12 applies to PV conductors over 10 feet from the PV array and requires that the conductors power down to 30 volts and 240 volt-amperes within 10 seconds of rapid shutdown initiation.

## String inverters require work arounds for rapid shutdown

### Work around.

Specialized Rapid Shutdown electrical box installed on the roof within 10 feet of array.

### Work around.

Shutoff switch that is easily accessible to first responders on the ground.

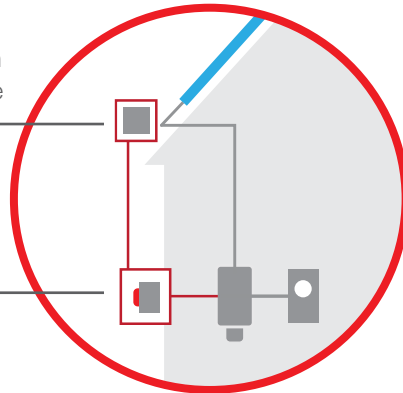

**Residential String Inverter**

### Work around.

String inverter installed on roof, a hostile environment that string inverters are not built to live in.

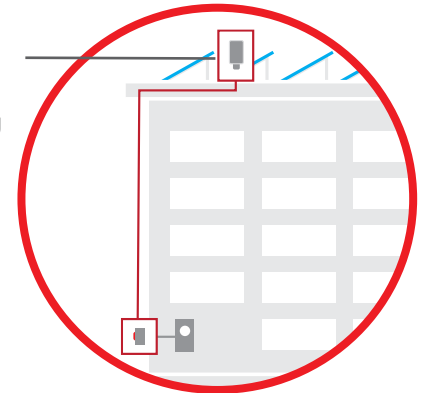

**Commercial String Inverter**

### Work around.

Extra conduit in installation.

## Enphase comes standard with rapid shutdown capability

All Enphase microinverters, even those that were previously installed, inherently meet rapid shutdown requirements, no additional equipment or workarounds needed

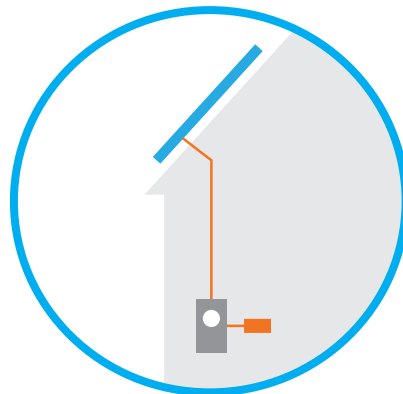

**Residential Microinverter**

Enphase microinverters can safely shut down automatically, leaving only low-voltage DC electricity isolated to the PV module

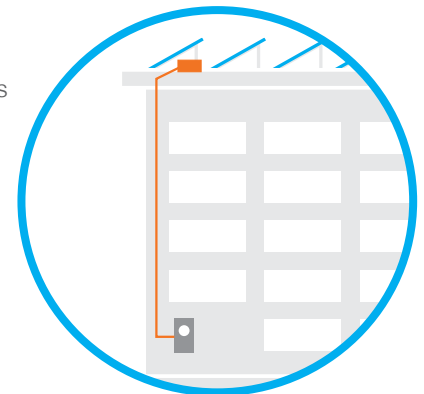

**Commercial Microinverter**

## One Clamp Anywhere

The Multi-Clamp works as mid- or end-clamp, and fits standard 30-40mm frames.

## Instant Bonding

The N-S Bonding Jumper bonds row to row with no tools.

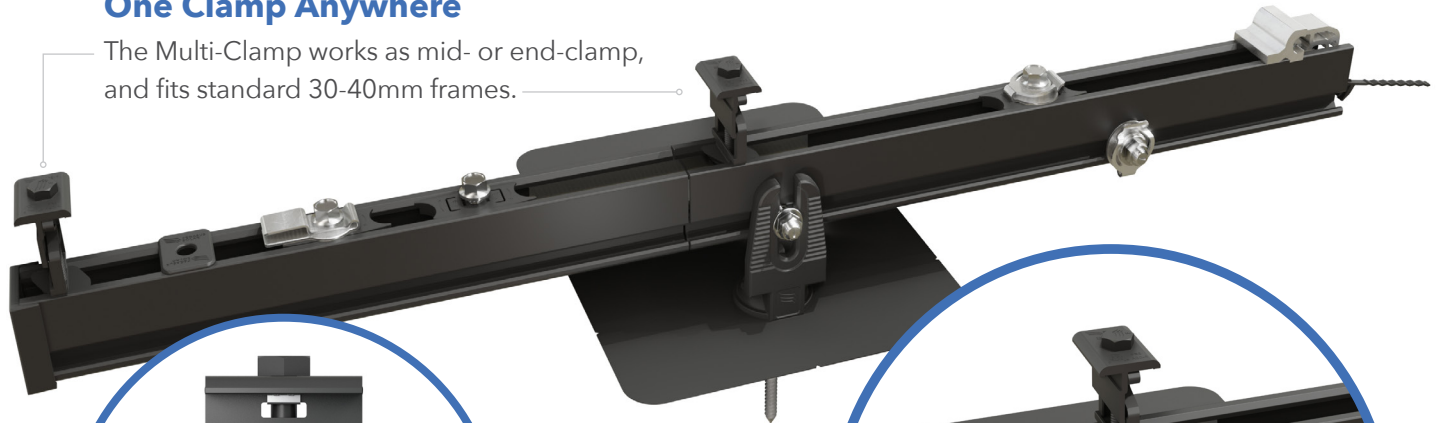

## Lifetime Wire Management

Open rail channel holds and protects wires. Clamps won't pinch wires after tightening.

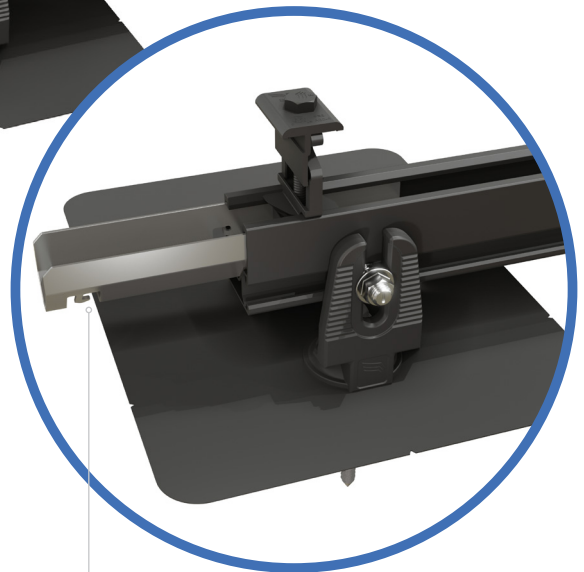

## Bonding Structural Splice

Connect rails instantly, without tools, interference or limitations.

## Next-Level Solar Mounting

A complete system for hassle-free rooftop installation, from watertight mounts to lifetime wire management.



### Simplicity

1/2" socket for everything.  
One clamp for mid or end.  
No tool splicing and bonding.  
Easy wire management.



### Code Compliant

UL 2703 listed  
LTR-AE-001-2012 listed  
Class A fire rating for any slope  
ASCE 7-16 PE Certified



### Premium Aesthetics

The narrowest panel gap available. Optional Hidden End Clamps and End Caps provide a flush look on the edge of the array.



### Watertight for Life

Secured on industry-leading Pegasus Mounts, for composite shingle and tile roofs. Backed by a 25-year warranty.



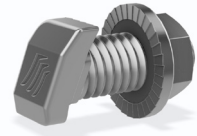
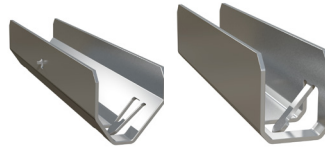
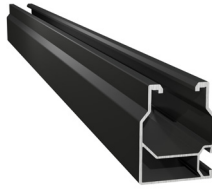

### Pegasus Rail

Available in 14' and 7' lengths for easy layout and shipping.  
Open-channel design holds MC4 connectors, PV wire and trunk cables.  
Black and Mill finish

### Pegasus Max Rail

Maximum-strength design.  
Meets specifications for high snow-load and hurricane zones.  
Black and Mill finish

### Splice and Max Splice

Installs by hand.  
Works over mounts.  
Structurally connects and bonds rails automatically; UL2703 listed as reusable.

### Dovetail T-bolt

Dovetail shape for extra strength.  
Uses 1/2" socket.



### Multi-Clamp

Fits 30-40mm PV frames, as mid- or end-clamp.  
Twist-locks into position; doesn't pinch wires in rail.  
Bonds modules to rail; UL2703 listed as reusable

### Hidden End Clamp

Offers premium edge appearance.  
Preinstalled pull-tab grips rail edge, allowing easy, one-hand installation.  
Tucks away for reuse.

### Ground Lug

Holds 6 or 8 AWG wire.  
Mounts on top or side of rail.  
Assembled on MLPE Mount.  
UL2703 listed as reusable.

### N-S Bonding Jumper

Installs by hand, eliminates row-to-row copper wire.  
UL2703 listed as reusable only with Pegasus Rail.

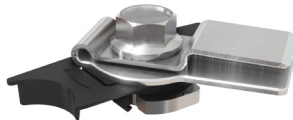

### MLPE Mount

Secures and bonds most micro-inverters and optimizers to rail.  
Connectors and wires easily route underneath after installation.  
UL2703 listed as reusable.

### Cable Grip

Secures four PV wires or two trunk cables.  
Stainless-steel backing provides durable grip.  
Eliminates sagging wires.

### Wire Clip

Hand operable.  
Holds wires in channel.  
Won't slip.

### End Cap and Max End Cap

Fits flush to PV module and hides raw or angled cuts.  
Hidden drain quickly clears water from rail.

#### Certifications:

- UL 2703, Edition 1
- LTR-AE-001-2012
- ASCE 7-16 PE certified
- Class A fire rating for any slope roof



Quickly calculate the most efficient layout, spans and materials needed to suit your job. Visit the Pegasus Customer Portal. [pegasussolar.com/portal](http://pegasussolar.com/portal)

LOAD		SPAN			
SNOW (PSF)	WIND (MPH)	32"	4'	6'	8'
0	120	PEGASUS RAIL			
	160	PEGASUS RAIL			PEGASUS MAX RAIL
	190	PEGASUS RAIL		PEGASUS MAX RAIL	
15	140	PEGASUS RAIL			PEGASUS MAX RAIL
	160	PEGASUS RAIL		PEGASUS MAX RAIL	
30	160	PEGASUS RAIL		PEGASUS MAX RAIL	
	190	PEGASUS RAIL		PEGASUS MAX RAIL	
45	190	PEGASUS RAIL		PEGASUS MAX RAIL	
70	190	PEGASUS RAIL		PEGASUS MAX RAIL	
110	190	PEGASUS RAIL		PEGASUS MAX RAIL	

For reference only. Spans above are calculated using ASCE 7-16 for a Gable Roof, Exposure Category B, 7-20deg roof angle, 30ft mean roof height with non-exposed modules. For PE certified span tables, visit [www.pegasussolar.com/spans](http://www.pegasussolar.com/spans).

Patents pending. All rights reserved. ©2021 Pegasus Solar Inc.

## One-Piece Flashing with Elevated Cone

No press-fits or deck-level EPDM washers to fail

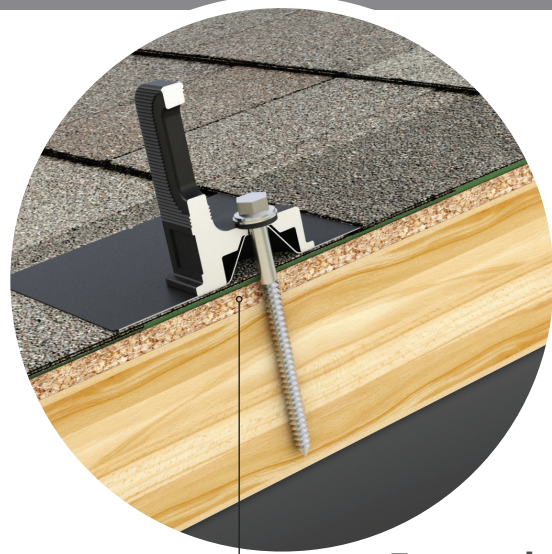

## Encapsulating Design

Raises the water seal 0.9" Above roof deck



## Simple 3-Piece Design Watertight For Life

Pegasus solar's comp mounts are a cost effective, high-quality option for rail installations on composition shingle roofs. Designed to last decades, the one-piece flashing with elevated cone means there is simply nothing to fail.



### 25-Year Warranty

Manufactured with advanced materials and coatings to outlast the roof itself



### Code Compliant

Fully IBC/CBC Code Compliant  
Exceeds ASCE 7-16 Standards



### Superior Waterproofing

Tested to AC286 without sealant  
Water seal elevated 0.9" above



### All-In-One Kit Packaging

Flashings, L-Feet and SS lags with bonded EPDM washers are included in each 24-pack

## 1

Drill pilot hole in the center of the rafter.

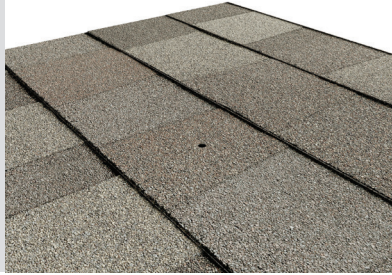

## 2

Optional: Apply a "u-shape" of sealant to the underside of the flashing and position under 2nd shingle course, cone over pilot hole.

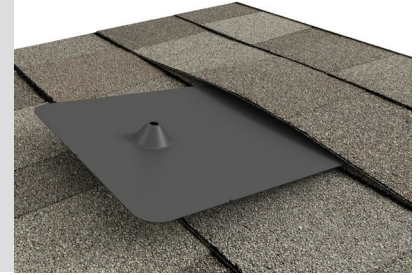

## 3

Place L-Foot over cone and install lag with washer through L-Foot.

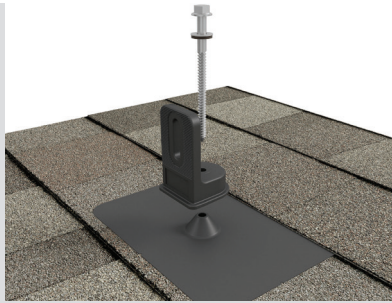

## 4

Drive lag to required depth. Attach rail per rail manufacturer's instructions.

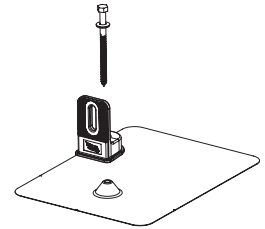
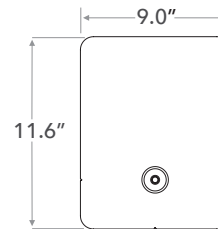
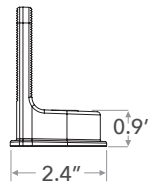
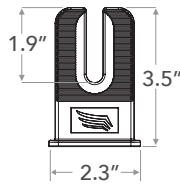
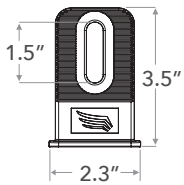
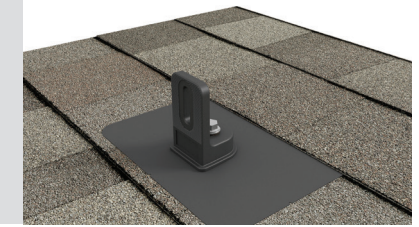

SPECIFICATIONS	COMP MOUNT INSTALL KITS				
SKU	PSCR-CBB0	PSCR-UBB0	SPCR-CBBH	PSCR-CMM0	PSCR-UMM0
Finish	Black L-Foot And Black Flashing			Mill	
L-Foot Type	Closed Slot	Open Slot	Closed Slot	Closed Slot	Open Slot
Kit Contents	L-Foot, Flashing, 5/16" x 4 1/2" SS Lag with metalized EPDM washer	L-Foot, Flashing, 5/16" x 4 1/2" SS Lag with metalized EPDM washer and M10 Hex Bolt	L-Foot, Flashing, 5/16" x 4 1/2" SS Lag with metalized EPDM washer	L-Foot, Flashing, 5/16" x 4 1/2" SS Lag with metalized EPDM washer	L-Foot, Flashing, 5/16" x 4 1/2" SS Lag with metalized EPDM washer
Roof Type	Composition Shingle				
Certifications	IBC, ASCE/SEI 7-16, AC286				
Install Application	Railed Systems				
Compatible Rail	Most				
Kit Quantity	24				
Boxes per Pallet	72				

Protected under US Patent: 10,998,847. Additional patents pending. All rights reserved. ©2021 Pegasus

# SolaDeck

PV ROOF-MOUNT ENCLOSURE

**INTRODUCED AT  
*SOLAR POWER 2007***



**UL50 Type 3R Enclosure • Stamped 18 gauge gal. steel • Powder coated finish  
• Weather tight**

## **Enclosure Includes:**

- Dual ground lug
- Universal DIN rail
- 1/2", 3/4" & 1" knockouts
- Wire strain relief clip
- Complete hardware package

## **PV Roof-Mount Combiner/Enclosure**

### **Benefits**

- The ability to prep the building is now possible
- Replaces several parts used today
- Provides professional looking install
- Saves time on install
- Allows for easy access
- Guaranteed seal to roof
- Low profile design

***For product information contact us at  
(866) 367-7782***

**[www.commdeck.com](http://www.commdeck.com)**



RSTC Enterprises, Inc  
2219 Heimstead Road  
Eau Claire, WI 54703  
1 (866) 367 - 7782



## **SolaDeck Part # 780**

### **Specifications:**

**18 Gauge Steel Base (1) and Cover (2)**  
**Pre Punched 7 holes in base (1) for roof deck**  
**Pre Punched 4 holes in base (1) and cover (2) for match**  
**Draw Process both parts**  
**Powder Coated to withstand 1000 hours Salt Spray (Primer Gray)**  
**High UV resistance**  
**15" x 15" flashing dimension**  
**Cavity dimension 8"W x 9" L x 2.5"D**  
**Approx. 162 Cubic inch equipment cavity**  
**Norloked steel base plate (3) to drawn base (2)**  
**Three knockout locations .5", .75" and 1"**  
**3" DIN rail installed**  
**Grounding Lug- Installed (In Equipment Cavity)**  
**Wire Strain Relief Clip –Installed (In Equipment Cavity)**  
**Hardware pack withstands 500 hours Salt Spray**  
**7 - 2" Trusshead Screws**  
**4 - .5" 8-32 thread cutting screws**  
**4 - #10 Bonded Seal washers**  
**1 – Foam closed Cell Seal**  
**ETL Listed UL50 Type 3R**

**Total Weight 6.9 pounds each**

### **Packaging:**

**Individually bagged and boxed**  
**Box dimension 15.5"w x 16" L x 3" D**  
**White Carton labeled with Cut out template**  
**Print One Color - Black**

**Master Cartons of 6 Units each**  
**Master Carton dimension 18.75"x16"x16.375"**  
**Master Carton Weight – 42 pounds**  
**18 Master Cartons per skid Approx 800 pounds with skid**

# Product data sheet

Specifications

SQUARE D

Green Premium™



Safety switch, general duty, fusible, 60A, 2 poles, 15 hp, 120 VAC, NEMA 3R, bolt-on provision, neutral factory installed

D222NRB

Product availability : Stock - Normally stocked in distribution facility

Price\* : 326.00 USD

## Main

Product	Single Throw Safety Switch
Duty Rating	General duty
Device Application	Residential
Disconnect Type	Fusible disconnect switch
Factory Installed Neutral	Neutral (factory installed)
Phase	3 phase
Number of Poles	2
Current Rating	60 A
Voltage Rating	240 V AC
Enclosure Rating NEMA	NEMA 3R
Maximum Horse Power Rating	1.5 hp 120 V at AC 60 Hz for 1 phase conforming to NEC 240.6 3 hp 120 V at AC 60 Hz for 3 phase conforming to NEC 430.52 3 hp 240 V at AC 60 Hz for 1 phase conforming to NEC 240.6 7.5 hp 240 V at AC 60 Hz for 3 phase conforming to NEC 240.6 10 hp 240 V at AC 60 Hz for 1 phase conforming to NEC 430.52 15 hp 240 V at AC 60 Hz for 3 phase conforming to NEC 430.52

## Complementary

Short Circuit Current Rating	100 kA maximum depending on fuse H, K or R
Fuse type	H, K or R
Mounting Type	Surface
Electrical Connection	Lugs
Wiring configuration	3-wire
Wire Size	AWG 12...AWG 3 aluminium AWG 14...AWG 3 copper
Tightening torque	35 lbf.in (3.95 N.m) 0.00...0.01 in <sup>2</sup> (2.08...5.26 mm <sup>2</sup> ) (AWG 14...AWG 10) 35 lbf.in (3.95 N.m) (AWG 14...AWG 10) 45 lbf.in (5.08 N.m) 0.01 in <sup>2</sup> (8.37 mm <sup>2</sup> ) (AWG 8) 45 lbf.in (5.08 N.m) 0.02...0.03 in <sup>2</sup> (12.3...21.12 mm <sup>2</sup> ) (AWG 6...AWG 4) 50 lbf.in (5.65 N.m) 0.04 in <sup>2</sup> (26.67 mm <sup>2</sup> ) (AWG 3)
Depth	4.87 in (123.70 mm)
Width	7.45 in (189.23 mm)

\* Price is "List Price" and may be subject to a trade discount – check with your local distributor or retailer for actual price.

Height	14.88 in (377.95 mm)
Product Weight	8.82 lb(US) (4 kg)

## Environment

Certifications	UL listed file E2875
----------------	----------------------

## Ordering and shipping details

Category	00106-D & DU SW,NEMA3R, 30-200A
Discount Schedule	DE1A
GTIN	785901460640
Nbr. of units in pkg.	1
Package weight(Lbs)	8.25 lb(US) (3.742 kg)
Returnability	Yes
Country of origin	US

## Packing Units

Unit Type of Package 1	PCE
Package 1 Height	5.20 in (13.208 cm)
Package 1 width	7.70 in (19.558 cm)
Package 1 Length	16.20 in (41.148 cm)
Unit Type of Package 2	PAL
Number of Units in Package 2	120
Package 2 Weight	1022.00 lb(US) (463.571 kg)
Package 2 Height	45.00 in (114.3 cm)
Package 2 width	40.00 in (101.6 cm)
Package 2 Length	48.00 in (121.92 cm)

## Offer Sustainability

Sustainable offer status	Green Premium product
California proposition 65	WARNING: This product can expose you to chemicals including: Lead and lead compounds, which is known to the State of California to cause cancer and birth defects or other reproductive harm. For more information go to <a href="http://www.P65Warnings.ca.gov">www.P65Warnings.ca.gov</a>
REACH Regulation	<a href="#">REACH Declaration</a>
REACH free of SVHC	Yes
EU RoHS Directive	Compliant <a href="#">EU RoHS Declaration</a>
Mercury free	Yes
RoHS exemption information	<a href="#">Yes</a>
China RoHS Regulation	<a href="#">China RoHS declaration</a> Product out of China RoHS scope. Substance declaration for your information.
Environmental Disclosure	<a href="#">Product Environmental Profile</a>
PVC free	Yes

## Contractual warranty

Warranty	18 months
----------	-----------

**Dimensions**

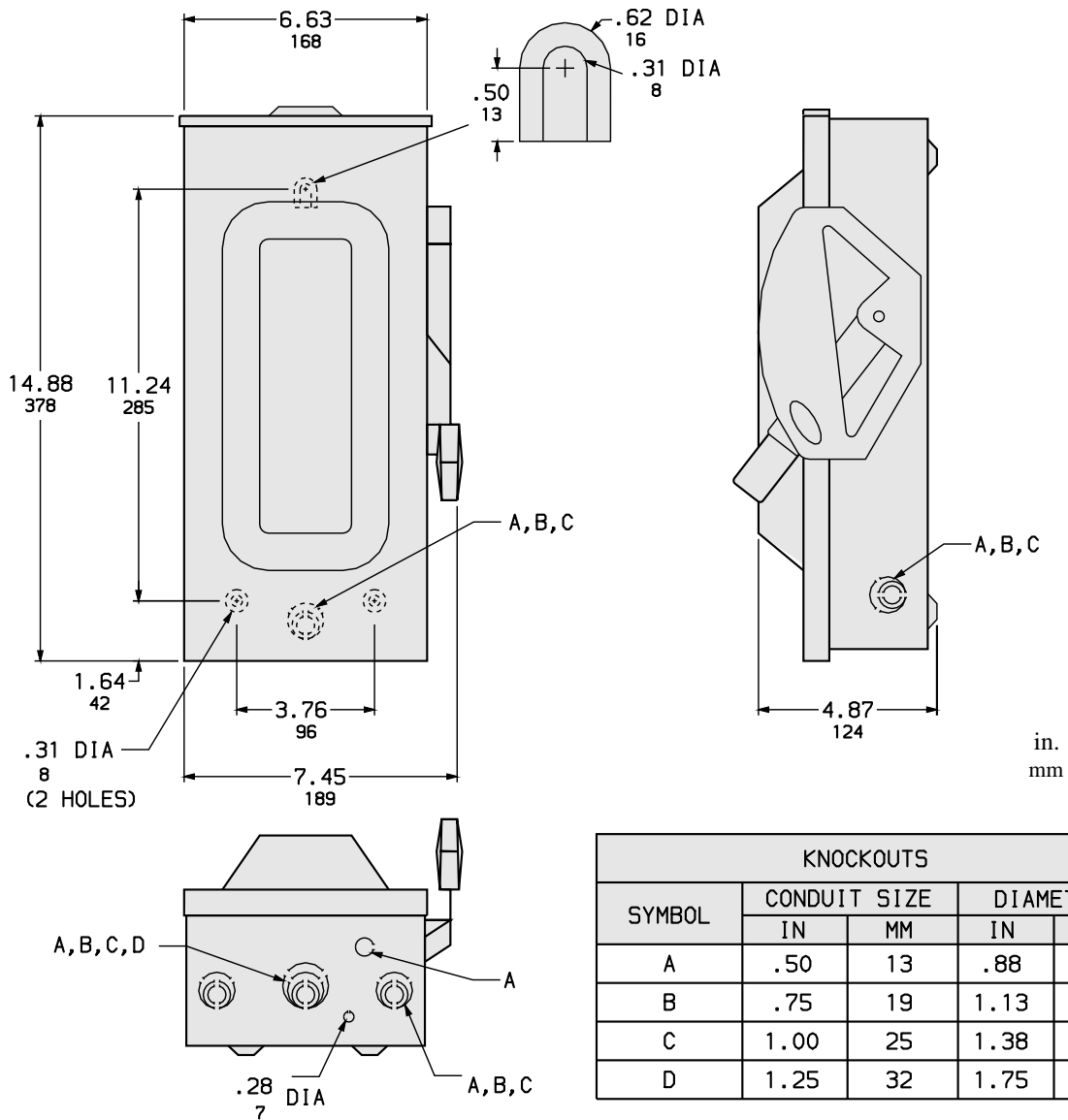

KNOCKOUTS				
SYMBOL	CONDUIT SIZE		DIAMETER	
	IN	MM	IN	MM
A	.50	13	.88	22
B	.75	19	1.13	29
C	1.00	25	1.38	35
D	1.25	32	1.75	45

ALL DIMENSIONS ARE APPROXIMATE.  
 REFER TO TECHNICAL DRAWINGS AND DOCUMENTS



Wiring Diagram

---

FUSIBLE

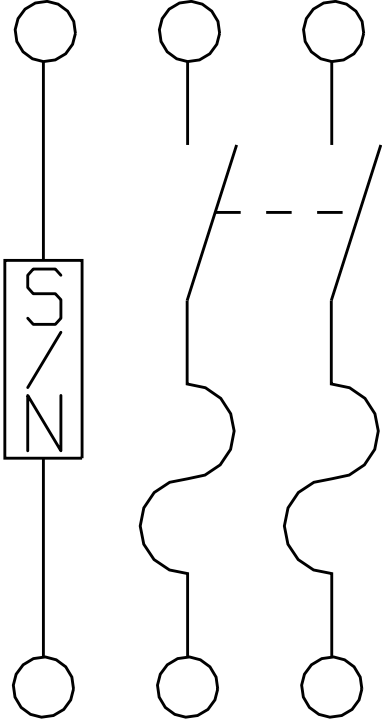

D222NRB