



Freedom Forever
Planset Revision Letter

2/7/2023
REV #1

Attn. Harnett County (NC):

The changes outlined in Revision Details have been applied to the plans corresponding to the following customer:

ADAM DAVIS
86 DERBY LANE, LILLINGTON, NC 27546

Revision Details:
LAYOUT CHANGE

All corresponding changes are notated on the plans by revision clouds.

Thank you for your time in reviewing these plans. Please reach out if you have any additional questions or concerns.

Construction Engineering
Freedom Forever
engineering@freedomforever.com

ROOF MOUNT PHOTOVOLTAIC SYSTEM

CODES:

THIS PROJECT COMPLIES WITH THE FOLLOWING:
 2018 NORTH CAROLINA BUILDING CODE
 2018 NORTH CAROLINA RESIDENTIAL CODE
 2018 NORTH CAROLINA PLUMBING CODE
 2018 NORTH CAROLINA MECHANICAL CODE
 2018 NORTH CAROLINA FUEL GAS CODE
 2017 NATIONAL ELECTRICAL CODE
 AS ADOPTED BY HARNETT COUNTY (NC)

CONSTRUCTION NOTES:

CONDUIT AND CONDUCTOR SPECIFICATIONS ARE BASED ON MINIMUM CODE REQUIREMENTS AND ARE NOT MEANT TO LIMIT UP-SIZING AS REQUIRED BY FIELD CONDITIONS.

ALL SOLAR ENERGY SYSTEM EQUIPMENT SHALL BE SCREENED TO THE MAXIMUM EXTENT POSSIBLE AND SHALL BE PAINTED A COLOR SIMILAR TO THE SURFACE UPON WHICH THEY ARE MOUNTED.

MODULES SHALL BE TESTED , LISTED AND IDENTIFIED WITH FIRE CLASSIFICATION IN ACCORDANCE WITH UL 2703. SMOKE AND CARBON MONOXIDE ALARMS ARE REQUIRED PER SECTION R314 AND 315 TO BE VERIFIED AND INSPECTED BY INSPECTOR IN THE FIELD.

DIG ALERT (811) TO BE CONTACTED AND COMPLIANCE WITH EXCAVATION SAFETY PRIOR TO ANY EXCAVATION TAKING PLACE

PHOTOVOLTAIC SYSTEM GROUND WILL BE TIED INTO EXISTING GROUND AT MAIN SERVICE FROM DC DISCONNECT/INVERTER AS PER 2017 AC SEC 250.166(A).

SOLAR PHOTOVOLTAIC SYSTEM EQUIPMENT WILL BE INSTALLED IN ACCORDANCE WITH REQUIREMENTS OF ART. 690 OF THE 2017 AC

THE MAIN SERVICE PANEL WILL BE EQUIPPED WITH A GROUND ROD OR UFER

UTILITY COMPANY WILL BE NOTIFIED PRIOR TO ACTIVATION OF THE SOLAR PV SYSTEM

SOLAREEDGE OPTIMIZERS ARE LISTED TO IEC 62109-1 (CLASS II SAFETY) AND UL 1741 STANDARDS

INSTALL CREW TO VERIFY ROOF STRUCTURE PRIOR TO COMMENCING WORK. EMT CONDUIT ATTACHED TO THE ROOF USING CONDUIT MOUNT.

VICINITY MAP:



SITE LOCATION

CLIENT:
 ADAM DAVIS
 86 DERBY LANE, LILLINGTON, NC 27546
 AHJ: HARNETT COUNTY (NC)
 UTILITY: DUKE ENERGY
 PHONE: 4345752698
 EMAIL: ARD315@YAHOO.COM
 FINANCE: OTHER



SYSTEM:
 SYSTEM SIZE (DC): 19 X 400 = 7.600 kW
 SYSTEM SIZE (AC): 6.000 kW @ 240V
 MODULES: 19 X FREEDOM FOREVER: FF-MP-BBB-400
 OPTIMIZERS: 19 X SOLAREEDGE S440
 INVERTER: SOLAREEDGE SE6000H-USRGM [S1]

TABLE OF CONTENTS:

PV-1	SITE LOCATION
PV-2	SITE PLAN
PV-2A	ROOF PLAN WITH MODULES LAYOUT
PV-2B	ROOF AND STRUCTURAL TABLES
PV-3	MOUNTING DETAILS
PV-4	THREE LINE DIAGRAM
PV-5	CONDUCTOR CALCULATIONS
PV-6	EQUIPMENT & SERVICE LIST
PV-7	LABELS
PV-7A	SITE PLACARD
PV-8	OPTIMIZER CHART
PV-9	SAFETY PLAN
PV-10	SAFETY PLAN
APPENDIX	MANUFACTURER SPECIFICATION SHEETS

REVISIONS		
NO.	REVISED BY	DATE
1	Y.A.	2/7/2023
-	-	-
-	-	-



FREEDOM FOREVER LLC
 415 INDUSTRIAL CT., GREER, SC 29651
 Tel: (800) 385-1075

GREG ALBRIGHT

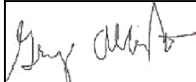









CONTRACTOR LICENSE:
 ELECTRICAL CONTRACTOR U.34043

SITE LOCATION

JOB NO: 299202	DATE: 2/7/2023	DESIGNED BY: Y.A.	SHEET: PV-1
-------------------	-------------------	----------------------	----------------

LEGEND:

-  CHIMNEY
-  PIPE VENT
-  MODULES
-  CONDUIT
-  SETBACK
-  AC DISCONNECT
-  JUNCTION BOX
-  INVERTER
-  MAIN SERVICE PANEL

THIS SYSTEM DESIGNED WITH:
 WIND SPEED: 130
 WIND EXPOSURE: B
 SNOW LOAD: 15

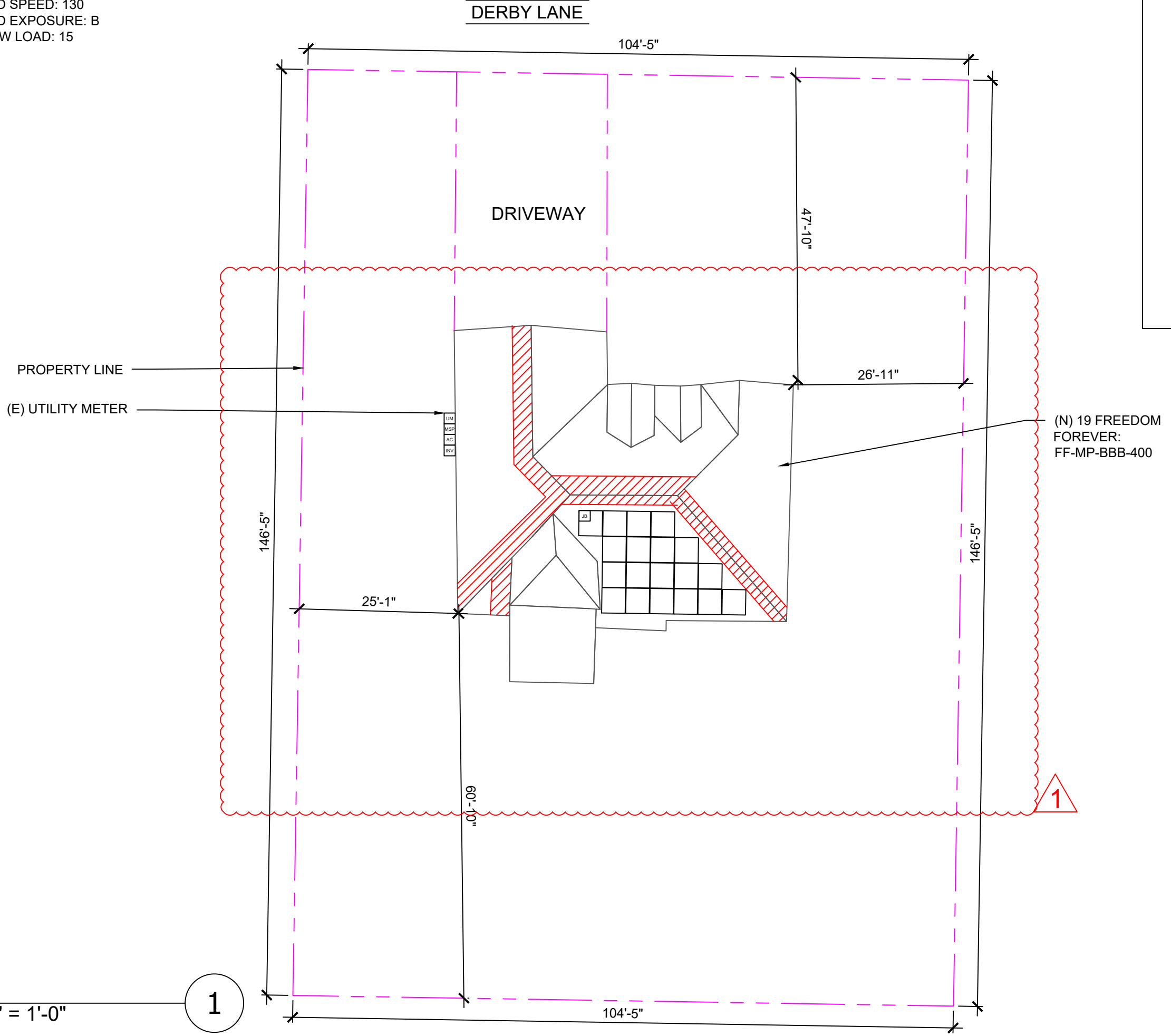

ROOF AREA: 3189 SQ FT

CLIENT:
 ADAM DAVIS
 86 DERBY LANE, LILLINGTON, NC 27546
 AHJ: HARNETT COUNTY (NC)
 UTILITY: DUKE ENERGY
 PHONE: 4345752698
 EMAIL: ARD315@YAHOO.COM
 FINANCE: OTHER

SYSTEM:
 SYSTEM SIZE (DC): 19 X 400 = 7.600 kW
 SYSTEM SIZE (AC): 6.000 kW @ 240V
 MODULES: 19 X FREEDOM FOREVER:
 FF-MP-BBB-400
 OPTIMIZERS: 19 X SOLAREEDGE S440
 INVERTER: SOLAREEDGE SE6000H-USRGM [S11]

REVISIONS		
NO.	REVISED BY	DATE
1	Y.A.	2/7/2023
-	-	-
-	-	-

freedom
 FOREVER

FREEDOM FOREVER LLC
 415 INDUSTRIAL CT., GREER, SC 29651
 Tel: (800) 385-1075

GREG ALBRIGHT









 CONTRACTOR LICENSE:
 ELECTRICAL CONTRACTOR U.34043

SITE PLAN
 SCALE: 1/16" = 1'-0"

1

SITE PLAN			
JOB NO:	DATE:	DESIGNED BY:	SHEET:
299202	2/7/2023	Y.A.	PV-2

LEGEND:

-  CHIMNEY
-  PIPE VENT
-  MODULES
-  CONDUIT
-  SETBACK
-  AC DISCONNECT
-  JUNCTION BOX
-  INVERTER
-  MAIN SERVICE PANEL

THIS SYSTEM DESIGNED WITH:
 WIND SPEED: 130
 WIND EXPOSURE: B
 SNOW LOAD: 15

TOTAL ROOF AREA: 3189 SQ FT
 TOTAL ARRAY AREA: 399.37 SQ FT
 ARRAY COVERAGE: 12.52%
 SYSTEM DISTRIBUTED WEIGHT: 2.32 LBS
 ROCKIT MICRORAIL POINT-LOAD: 21.52 LBS

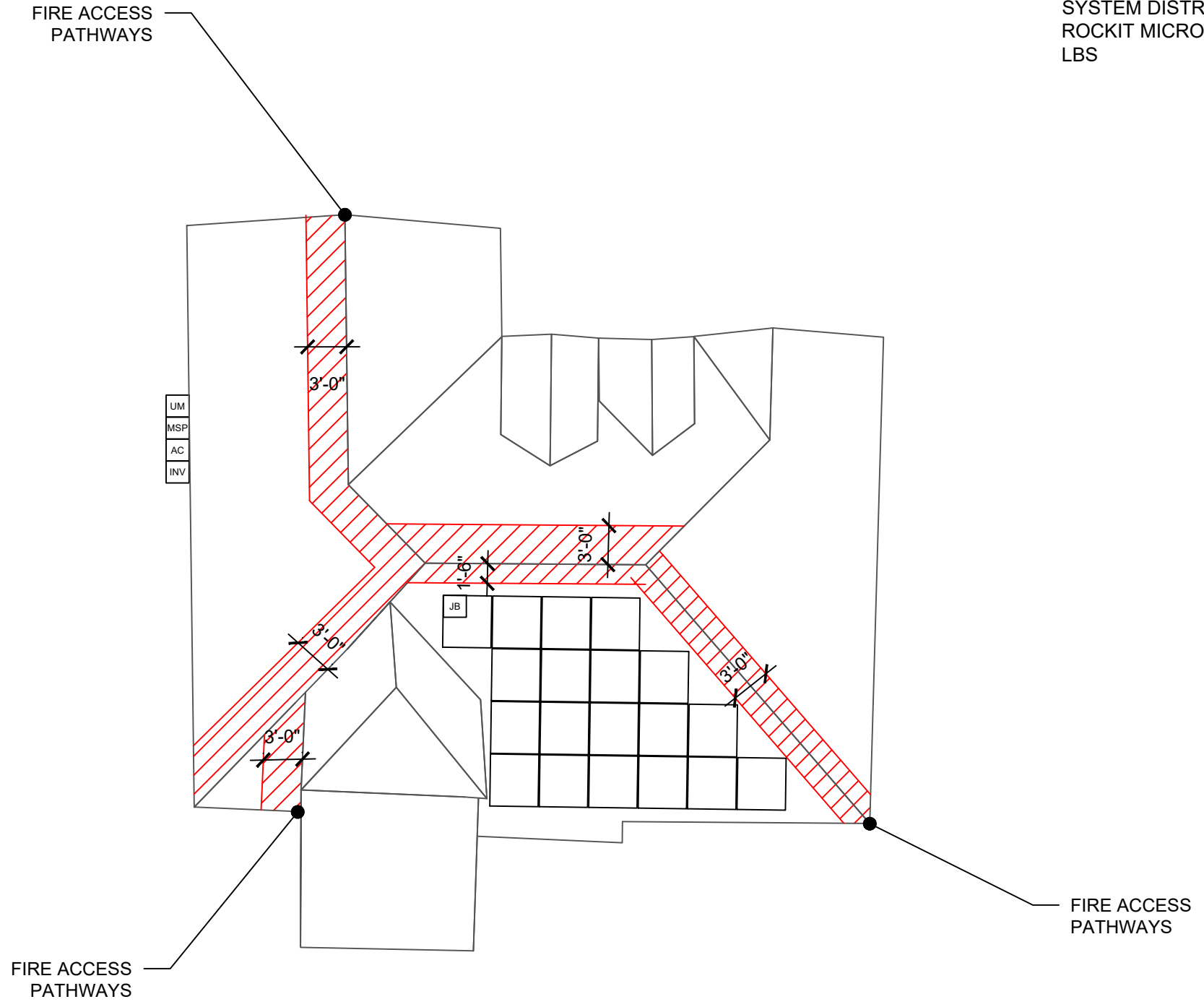

ROOF AREA: 3189 SQ FT

CLIENT:
 ADAM DAVIS
 86 DERBY LANE, LILLINGTON, NC 27546
 AHJ: HARNETT COUNTY (NC)
 UTILITY: DUKE ENERGY
 PHONE: 4345752698
 EMAIL: ARD315@YAHOO.COM
 FINANCE: OTHER

SYSTEM:
 SYSTEM SIZE (DC): 19 X 400 = 7.600 kW
 SYSTEM SIZE (AC): 6.000 kW @ 240V
 MODULES: 19 X FREEDOM FOREVER:
 FF-MP-BBB-400
 OPTIMIZERS: 19 X SOLAREEDGE S440
 INVERTER: SOLAREEDGE SE6000H-USRGM [S1]

REVISIONS		
NO.	REVISED BY	DATE
1	Y.A.	2/7/2023
-	-	-
-	-	-



FREEDOM FOREVER LLC
 415 INDUSTRIAL CT., GREER, SC 29651
 Tel: (800) 385-1075

GREG ALBRIGHT

CONTRACTOR LICENSE:
 ELECTRICAL CONTRACTOR U.34043

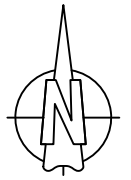

ROOF PLAN
 SCALE: 3/32" = 1'-0"

1

- NOTES:**
1. EMT CONDUIT ATTACHED TO THE ROOF USING CONDUIT MOUNTS
 2. ATTACHED CLAMPS AT 25% FROM THE EDGE AND 50% FROM THE CENTER OF THE MODULES
 3. JUNCTION BOX IS MOUNTED TO THE RAIL.

ROOF PLAN WITH MODULES LAYOUT

JOB NO: 299202	DATE: 2/7/2023	DESIGNED BY: Y.A.	SHEET: PV-2A
-------------------	-------------------	----------------------	-----------------

ROOF DETAILS:

TOTAL ROOF AREA: 3189 SQ FT
 TOTAL ARRAY AREA: 399.37 SQFT
 ARRAY COVERAGE: 12.52%
 SYSTEM DISTRIBUTED WEIGHT: 2.32 LBS
 ROCKIT MICRORAIL POINT-LOAD: 21.52 LBS

ROOF AREA STATEMENT						
ROOF	MODULE QUANTITY	ROOF PITCH	ARRAY PITCH	AZIMUTH	ROOF AREA	ARRAY AREA
ROOF 1	19	45	45	181	825 SQ FT	399.37 SQ FT

CLIENT:
 ADAM DAVIS
 86 DERBY LANE, LILLINGTON, NC 27546
 AHJ: HARNETT COUNTY (NC)
 UTILITY: DUKE ENERGY
 PHONE: 4345752698
 EMAIL: ARD315@YAHOO.COM
 FINANCE: OTHER

SYSTEM:
 SYSTEM SIZE (DC): 19 X 400 = 7.600 kW
 SYSTEM SIZE (AC): 6.000 kW @ 240V
 MODULES: 19 X FREEDOM FOREVER:
 FF-MP-BBB-400
 OPTIMIZERS: 19 X SOLAREEDGE S440
 INVERTER: SOLAREEDGE SE6000H-USRGM [S1]

REVISIONS		
NO.	REVISED BY	DATE
1	Y.A.	2/7/2023
-	-	-
-	-	-



FREEDOM FOREVER LLC
 415 INDUSTRIAL CT., GREER, SC 29651
 Tel: (800) 385-1075

GREG ALBRIGHT

CONTRACTOR LICENSE:
 ELECTRICAL CONTRACTOR U.34043

ROOF DETAILS

JOB NO: 299202	DATE: 2/7/2023	DESIGNED BY: Y.A.	SHEET: PV-2B
-------------------	-------------------	----------------------	-----------------

BACKFEED BREAKER SIZING
 MAX. CONTINUOUS OUTPUT 25.00A @ 240V
 25.00 X 1.25 = 31.25AMPS 35A BREAKER - OK
 SEE 705.12 OF 2017 AC
 200 X 1.20 = 240
 240 - 200 = 40A ALLOWABLE BACKFEED

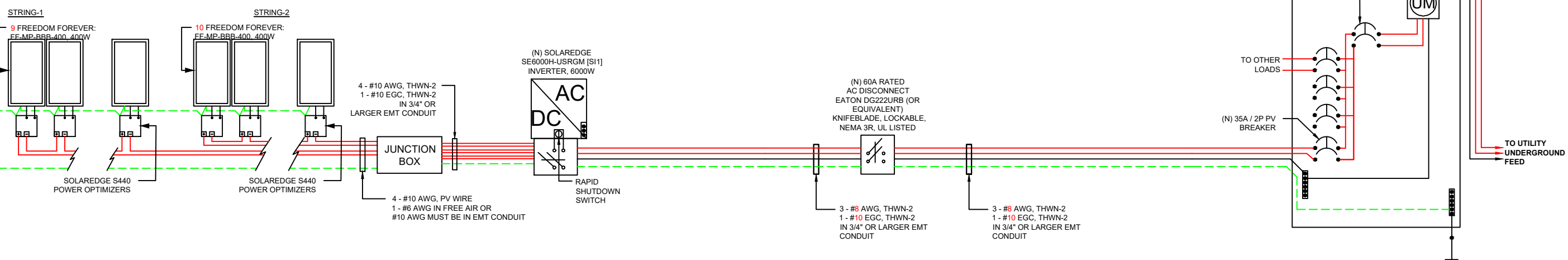

CLIENT:
 ADAM DAVIS
 86 DERBY LANE, LILLINGTON, NC 27546
 AHJ: HARNETT COUNTY (NC)
 UTILITY: DUKE ENERGY
 PHONE: 4345752698
 EMAIL: ARD315@YAHOO.COM
 FINANCE: OTHER

SYSTEM:
 SYSTEM SIZE (DC): 19 X 400 = 7.600 kW
 SYSTEM SIZE (AC): 6.000 kW @ 240V
 MODULES: 19 X FREEDOM FOREVER: FF-MP-BBB-400
 OPTIMIZERS: 19 X SOLAREEDGE S440
 INVERTER: SOLAREEDGE SE6000H-USRGM [S11]

REVISIONS		
NO.	REVISED BY	DATE
1	Y.A.	2/7/2023
-	-	-
-	-	-

freedom FOREVER
 FREEDOM FOREVER LLC
 415 INDUSTRIAL CT., GREER, SC 29651
 Tel: (800) 385-1075

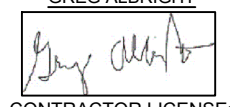
GREG ALBRIGHT

 CONTRACTOR LICENSE:
 ELECTRICAL CONTRACTOR U.34043

NOTE:
 CONDUIT AND CONDUCTORS SPECIFICATIONS ARE BASED ON MINIMUM CODE REQUIREMENTS AND ARE NOT MEANT TO LIMIT UP-SIZING AS REQUIRED BY FIELD CONDITIONS

THREE LINE DIAGRAM

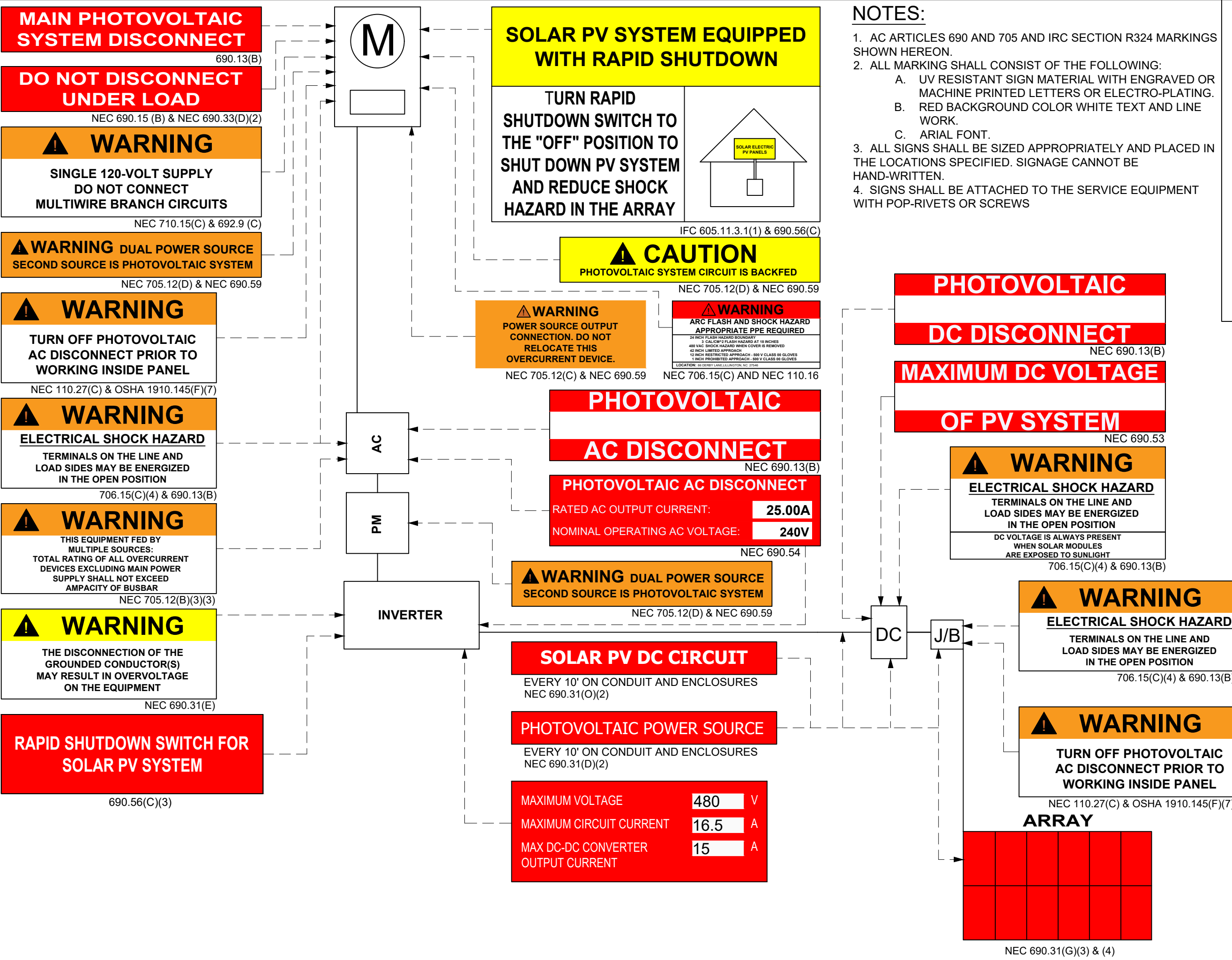
JOB NO: 299202	DATE: 2/7/2023	DESIGNED BY: Y.A.	SHEET: PV-4
-------------------	-------------------	----------------------	----------------



- NOTES:**
- AC ARTICLES 690 AND 705 AND IRC SECTION R324 MARKINGS SHOWN HEREON.
 - ALL MARKING SHALL CONSIST OF THE FOLLOWING:
 - UV RESISTANT SIGN MATERIAL WITH ENGRAVED OR MACHINE PRINTED LETTERS OR ELECTRO-PLATING.
 - RED BACKGROUND COLOR WHITE TEXT AND LINE WORK.
 - ARIAL FONT.
 - ALL SIGNS SHALL BE SIZED APPROPRIATELY AND PLACED IN THE LOCATIONS SPECIFIED. SIGNAGE CANNOT BE HAND-WRITTEN.
 - SIGNS SHALL BE ATTACHED TO THE SERVICE EQUIPMENT WITH POP-RIVETS OR SCREWS

CLIENT:
ADAM DAVIS
86 DERBY LANE, LILLINGTON, NC 27546
AHJ: HARNETT COUNTY (NC)
UTILITY: DUKE ENERGY
PHONE: 4345752698
EMAIL: ARD315@YAHOO.COM
FINANCE: OTHER

SYSTEM:
SYSTEM SIZE (DC): 19 X 400 = 7.600 kW
SYSTEM SIZE (AC): 6.000 kW @ 240V
MODULES: 19 X FREEDOM FOREVER: FF-MP-BBB-400
OPTIMIZERS: 19 X SOLAREEDGE S440
INVERTER: SOLAREEDGE SE6000H-USRGM [S11]

REVISIONS		
NO.	REVISED BY	DATE
1	Y.A.	2/7/2023
-	-	-
-	-	-

freedom FOREVER

FREEDOM FOREVER LLC
415 INDUSTRIAL CT., GREER, SC 29651
Tel: (800) 385-1075

GREG ALBRIGHT

CONTRACTOR LICENSE:
ELECTRICAL CONTRACTOR U.34043

LABELS			
JOB NO:	DATE:	DESIGNED BY:	SHEET:
299202	2/7/2023	Y.A.	PV-7

CAUTION:

POWER TO THIS BUILDING IS ALSO SUPPLIED FROM THE FOLLOWING SOURCES WITH DISCONNECTS AS SHOWN

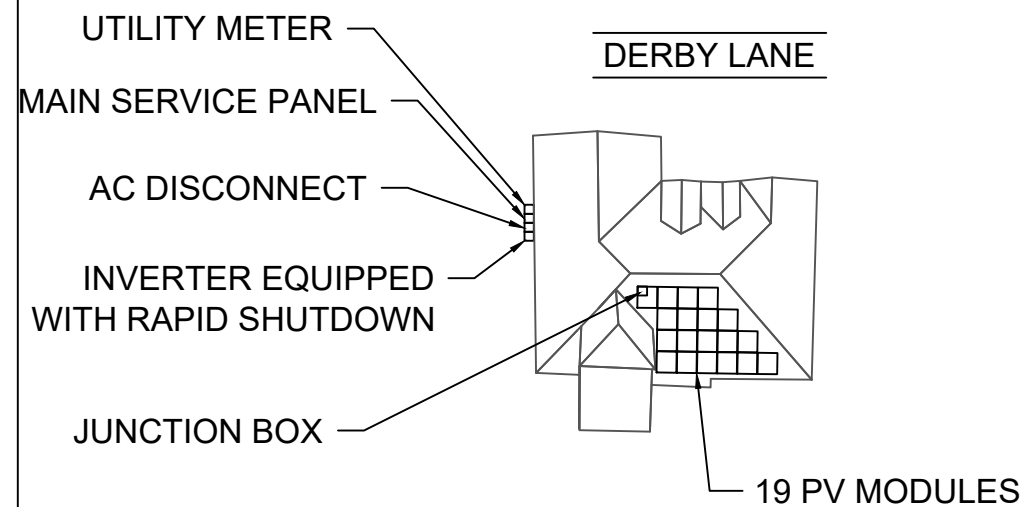

WARNING
TURN OFF PHOTOVOLTAIC AC DISCONNECT
PRIOR TO WORKING INSIDE PANEL



CLIENT:
 ADAM DAVIS
 86 DERBY LANE, LILLINGTON, NC 27546
 AHJ: HARNETT COUNTY (NC)
 UTILITY: DUKE ENERGY
 PHONE: 4345752698
 EMAIL: ARD315@YAHOO.COM
 FINANCE: OTHER

SYSTEM:
 SYSTEM SIZE (DC): 19 X 400 = 7.600 kW
 SYSTEM SIZE (AC): 6.000 kW @ 240V
 MODULES: 19 X FREEDOM FOREVER:
 FF-MP-BBB-400
 OPTIMIZERS: 19 X SOLAREEDGE S440
 INVERTER: SOLAREEDGE SE6000H-USRGM [S1]

REVISIONS		
NO.	REVISED BY	DATE
1	Y.A.	2/7/2023
-	-	-
-	-	-



FREEDOM FOREVER LLC
 415 INDUSTRIAL CT., GREER, SC 29651
 Tel: (800) 385-1075

GREG ALBRIGHT

CONTRACTOR LICENSE:
 ELECTRICAL CONTRACTOR U.34043

SITE PLACARD

JOB NO:	DATE:	DESIGNED BY:	SHEET:
299202	2/7/2023	Y.A.	PV-7A

NOTES:

- AC ARTICLES 690 AND 705 AND IRC SECTION R324 MARKINGS SHOWN HEREON.
- ALL MARKING SHALL CONSIST OF THE FOLLOWING:
 - UV RESISTANT SIGN MATERIAL WITH ENGRAVED OR MACHINE PRINTED LETTERS OR ELECTRO-PLATING.
 - RED BACKGROUND COLOR WHITE TEXT AND LINE WORK.
 - AERIAL FONT.
- ALL SIGNS SHALL BE SIZED APPROPRIATELY AND PLACED IN THE LOCATIONS SPECIFIED. SIGNAGE CANNOT BE HAND-WRITTEN.
- SIGNS SHALL BE ATTACHED TO THE SERVICE EQUIPMENT WITH POP-RIVETS OR SCREWS.

SOLAREEDGE OPTIMIZER CHART

1-10 11-20 21-30 31-40 41-50 51-60

1
2
3
4
5
6
7
8
9
10

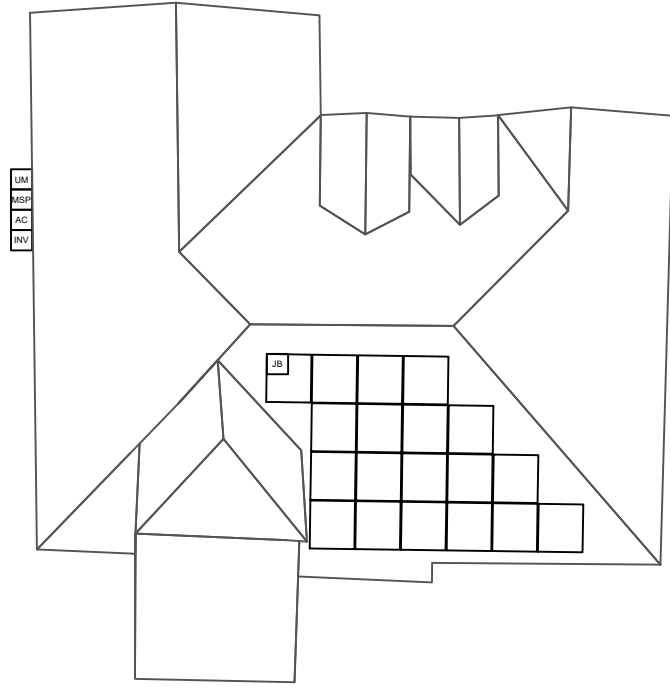

CLIENT:
 ADAM DAVIS
 86 DERBY LANE, LILLINGTON, NC 27546
 AHJ: HARNETT COUNTY (NC)
 UTILITY: DUKE ENERGY
 PHONE: 4345752698
 EMAIL: ARD315@YAHOO.COM
 FINANCE: OTHER

SYSTEM:
 SYSTEM SIZE (DC): 19 X 400 = 7.600 kW
 SYSTEM SIZE (AC): 6.000 kW @ 240V
 MODULES: 19 X FREEDOM FOREVER:
 FF-MP-BBB-400
 OPTIMIZERS: 19 X SOLAREEDGE S440
 INVERTER: SOLAREEDGE SE6000H-USRGM [S1]

REVISIONS		
NO.	REVISED BY	DATE
1	Y.A.	2/7/2023
-	-	-
-	-	-



FREEDOM FOREVER LLC
 415 INDUSTRIAL CT., GREER, SC 29651
 Tel: (800) 385-1075

GREG ALBRIGHT

CONTRACTOR LICENSE:
 ELECTRICAL CONTRACTOR U.34043

OPTIMIZER CHART			
JOB NO:	DATE:	DESIGNED BY:	SHEET:
299202	2/7/2023	Y.A.	PV-8

SAFETY PLAN

MARK UP KEY

INSTRUCTIONS:

- USE SYMBOLS IN KEY TO MARK UP THIS SHEET.
- SAFETY PLAN MUST BE MARKED BEFORE JOB STARTS AS PART OF THE PRE-PLAN
- DOCUMENT ALL ADDITIONAL HAZARDS ON THIS PAGE & MAKE NOTES ON THE JHA SHEET

INCIDENT REPORTING:

INJURIES - CALL INJURY HOTLINE

(855) 400-7233

**If injury is life threatening, call 911 first THEN the Injury Hotline*

NON-INJURIES - USE MOBILE INCIDENT REPORTING

(Auto, Property Damage, Near Miss)



NEAREST OCCUPATIONAL/INDUSTRIAL CLINIC:

NAME: _____

ADDRESS: _____

NEAREST HOSPITAL:

NAME: _____

ADDRESS: _____

SAFETY COACH CONTACT INFORMATION:

NAME: _____

PHONE NUMBER: _____

ALL EMPLOYEES ON SITE SHALL BE MADE AWARE OF THE SAFETY PLAN AND SIGN INDICATING THAT THEY ARE AWARE OF THE HAZARDS ON-SITE AND THE PLAN FOR WORKING SAFELY.

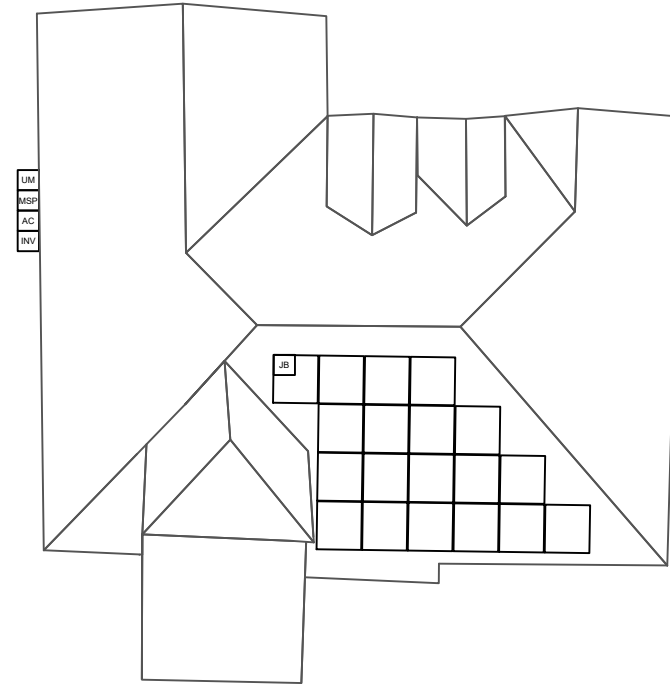

- (P)** PERMANENT ANCHOR
- (T)** TEMPORARY ANCHOR
- IL** INSTALLER LADDER
- B** JUNCTION / COMBINER BOX
- S** STUB-OUT
- ☒** SKYLIGHT
- ☁** NO LADDER ACCESS (STEEP GRADE OR GROUND LEVEL OBSTRUCTIONS)
- RESTRICTED ACCESS
- CONDUIT
- (GAS)** GAS SHUT OFF
- (H₂O)** WATER SHUT OFF
- (7)** SERVICE DROP
- (Z)** POWER LINES

CLIENT:
 ADAM DAVIS
 86 DERBY LANE, LILLINGTON, NC 27546
 AHJ: HARNETT COUNTY (NC)
 UTILITY: DUKE ENERGY
 PHONE: 4345752698
 EMAIL: ARD315@YAHOO.COM
 FINANCE: OTHER

SYSTEM:
 SYSTEM SIZE (DC): 19 X 400 = 7.600 kW
 SYSTEM SIZE (AC): 6.000 kW @ 240V
 MODULES: 19 X FREEDOM FOREVER:
 FF-MP-BBB-400
 OPTIMIZERS: 19 X SOLAREEDGE S440
 INVERTER: SOLAREEDGE SE6000H-USRGM [S11]

BREAK AND WATER LOG

THIS LOG IS TO BE FILLED OUT ANY TIME THE TEMP EXCEEDS **90** DEGREES. THE CREW LEAD AND ROOF LEAD ARE RESPONSIBLE FOR ENSURING THIS IS COMPLETED AND UPLOADED AT THE END OF EVERYDAY WHEN TEMPS EXCEED **90** DEGREES

NAME	0800HRS	0900HRS	1000HRS	1100HRS	1200HRS	1300HRS	1400HRS	1500HRS	1600HRS

REVISIONS		
NO.	REVISED BY	DATE
1	Y.A.	2/7/2023
-	-	-
-	-	-

FREEDOM FOREVER LLC
 415 INDUSTRIAL CT., GREER, SC 29651
 Tel: (800) 385-1075

GREG ALBRIGHT

CONTRACTOR LICENSE:
 ELECTRICAL CONTRACTOR U.34043

NAME	SIGNATURE

DATE: _____ TIME: _____

SAFETY PLAN			
JOB NO:	DATE:	DESIGNED BY:	SHEET:
299202	2/7/2023	Y.A.	PV-9

JOB HAZARD ANALYSIS

Crew leader to fill out all sections below, hold a pre-job safety meeting with all personnel, and upload this completed document and the Safety Plan to Site Capture

Ladder Access

- Ladders must be inspected before each use.
- Extension ladders must be set up on a firm and level surface at a 4-to-1 rise to run angle (or 75 degrees) and the top must be secured to the structure. Extension style ladders placed on uneven, loose or slippery surfaces must additionally have the base firmly anchored or lashed so the base will not slip out.
- Extension ladders must be used with walk-through devices or the ladder must extend 36" above the stepping off point.
- A-frame ladders must only be climbed with the ladder spreader bars locked in the open position; A-frame ladders shall not be climbed while in the closed position (ex, closed and used while leaned against a structure).

Additional notes:

Mobile Equipment

- Only Qualified operators will operate equipment; operators must maintain a certification on their person for the equipment being operated.
- Type(s) of mobile equipment (Type/Make/Model):
- Qualified operator(s):

Material Handling and Storage

- Materials will be staged/stored in a way that does not present a hazard to client, personnel or public. Materials stored on the roof will be physically protect from falling or sliding off.

Fall Protection

- A site-specific plan for fall prevention and protection is required prior to starting work and must remain onsite at all times until work is complete; a fall rescue plan must be outlined and discussed among the crew prior to work start.
- First-person-Up (FPU) must install their anchor and connect before any other task, including installing other anchors. The Last-Person-Down (LPD) must be the only person on a roof uninstalling fall protection.

FPCP (name and title):

FPU and LPD (name and title):

Electrical Safety

- The Electrical Qualified Person (EQP) is required onsite to perform electrical work.
- All electrical work will be performed with equipment in an electrically safe condition (de-energized) unless approval has been granted prior to work.
- Service drops and overhead electrical hazards will be identified and protected from contact, as neccessary.

EQP (name and tile):

Public Protection

- The safety of the Client and Public must be maintained at all times.
- The Client and the Public shall be prevented from entering the work zone through the use of barriers and/or signage, as required.
- Company, Client and Public property shall be protected from falling objects.
- Pets (including dogs) shall be secured by their owners prior to work start.
- The Client should not leave pets, family members, or others in charge or care of Employees, Contractors, or Temporary Workers.

Crew leader responsible for communication with the client:

Client and public is excluded from work area by barricades (N/A, Yes, No):

Training and Pre-Job Safety Briefing

- All employees onsite shall be made aware of the specific hazards of this project and review this HJA during a pre-job briefing, and their signature indicates awareness of site conditions and the plan to eliminate any hazards identified prior to and during the project.

Crew leader (name/title):

Crew member (name/title):

Crew member (name/title):

Crew member (name/title):

Crew member (name/title):

Crew member (name/title):

Crew member (name/title):

Airborne Contaminants:

- Asbestos-containing (Transite) piping (ACP) - Do not disturb (move, drill, cut fracture, etc.)
- Asbestos-containing thermal insulation (ACI) and Asbestos-containing duct wrapping (ACW) - do not disturb, no attic or crawlspace access is allowed if work to be performed could cause exposure to personnel, client or public.

If yes, list specific tasks and protection in place:

Weather and Environment

- The site supervisor shall forecast the weather conditions at the job site, prior to crew arrival, in order to mitigate any hazards associated with inclement weather (heat, cold, wind, rain, etc.)
- The site supervisor will utilized a portable wind meter (anemometer) to verify actual onsite wind conditions, by checking at the ground and on any elevated work surface (ex, rooftop) prior to work start, at midday and prior to solar panel staging on a roof.
- Elevated work involving the moving or maneuvering of solar panels shall cease at 25mph (sustained wind) until wind subsides.

Forecasted weather maximum temp (degrees f):

Heat Related Illness Prevention

- Employees shall have access to potable drinking water that is fresh, pure, and suitably cool. The water shall be located as close as practicable to the areas where employees are working. Water shall be supplied in sufficient quantity at the beginning of the work shift to provide at least one quart per employee per hour for drinking for the entire shift. Employees may begin the shift with smaller quantities of water if they identify the location and have effective means for replenishment during the shift to allow employees to drink on quart or more per hour. The frequent drinking of water shall be encouraged.
- Shade shall be present when temperature exceeds 80 degrees Fahrenheit. When the outdoor temperature in the work exceeds 80 degrees Fahrenheit, employees shall have and maintain one or more areas with shade at all times.
- New employees must be acclimatized. New employees will be monitored by their Crew Leader (site supervisor) for the first two (2) weeks of employment or longer when necessary.
- Employees will be allowed and encouraged to implement scheduled breaks during each shift. Employees must take cool-down breaks in the shade any time they feel the need to do so to protect them from overheating. Supervisors are REQUIRED to allow employees any break period they need during high heat conditions.
- Cool Vests are encouraged for all employees at all times during periods of high heat.
- Identify the location of the closet Occupational/Industrial Clinic or Hospital in case a crew member becomes ill.

What is the specific plan to provide and replenish sufficient water for all employees on site?

If offsite replenish is necessary, where will you go to replenish water (location/address):

Who will replenish the drinking water (name):

Restroom facilities

- Employees shall have access to restroom facilities with hand-washing stations. Use of onsite restroom is at the client's discretion (location is annotated below). If client does not give permission, location of suitable restroom facilities with hand-washing stations offsite will be provided. The onsite supervisor will identify location and make arrangements to ensure all employees have access at any point.

Restroom facilities will be (circle one): Onsite - Offsite

If Offsite, add location name and address:

Incident Reporting Procedure

- Contact your Site Supervisor

Name:

Phone:

- Contact your Manager

Name:

Phone:

- Contact your Site Supervisor

Name:

Phone:

With: Your full name, phone number, office location, brief description of what happen and when.

NOTE ADDITIONAL HAZARDS NOT ADDRESSED ABOVE

(add as many as necessary by using additional sheets)

Define the Hazard:	Method/steps to prevent incident:
Define the Hazard:	Method/steps to prevent incident:
Define the Hazard:	Method/steps to prevent incident:
Define the Hazard:	Method/steps to prevent incident:

CLIENT:
 ADAM DAVIS
 86 DERBY LANE, LILLINGTON, NC 27546
 AHJ: HARNETT COUNTY (NC)
 UTILITY: DUKE ENERGY
 PHONE: 4345752698
 EMAIL: ARD315@YAHOO.COM
 FINANCE: OTHER

SYSTEM:
 SYSTEM SIZE (DC): 19 X 400 = 7.600 kW
 SYSTEM SIZE (AC): 6.000 kW @ 240V
 MODULES: 19 X FREEDOM FOREVER:
 FF-MP-BBB-400
 OPTIMIZERS: 19 X SOLAREEDGE S440
 INVERTER: SOLAREEDGE SE6000H-USRGM [S11]

REVISIONS		
NO.	REVISED BY	DATE
1	Y.A.	2/7/2023
-	-	-
-	-	-



FREEDOM FOREVER LLC
 415 INDUSTRIAL CT., GREER, SC 29651
 Tel: (800) 385-1075

GREG ALBRIGHT



CONTRACTOR LICENSE:
 ELECTRICAL CONTRACTOR U.34043

SAFETY PLAN			
JOB NO:	DATE:	DESIGNED BY:	SHEET:
299202	2/7/2023	Y.A.	PV-10



MACH 2 400W MODULE

FF-MP-BBB-400

High module conversion efficiency up to 20.48%

Excellent weak light performance

Withstanding harsh environment

Lower operating temperature

Extreme weather loading

12-year material & workmanship

25-year linear power output

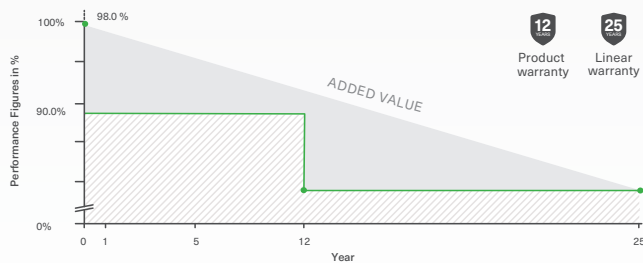
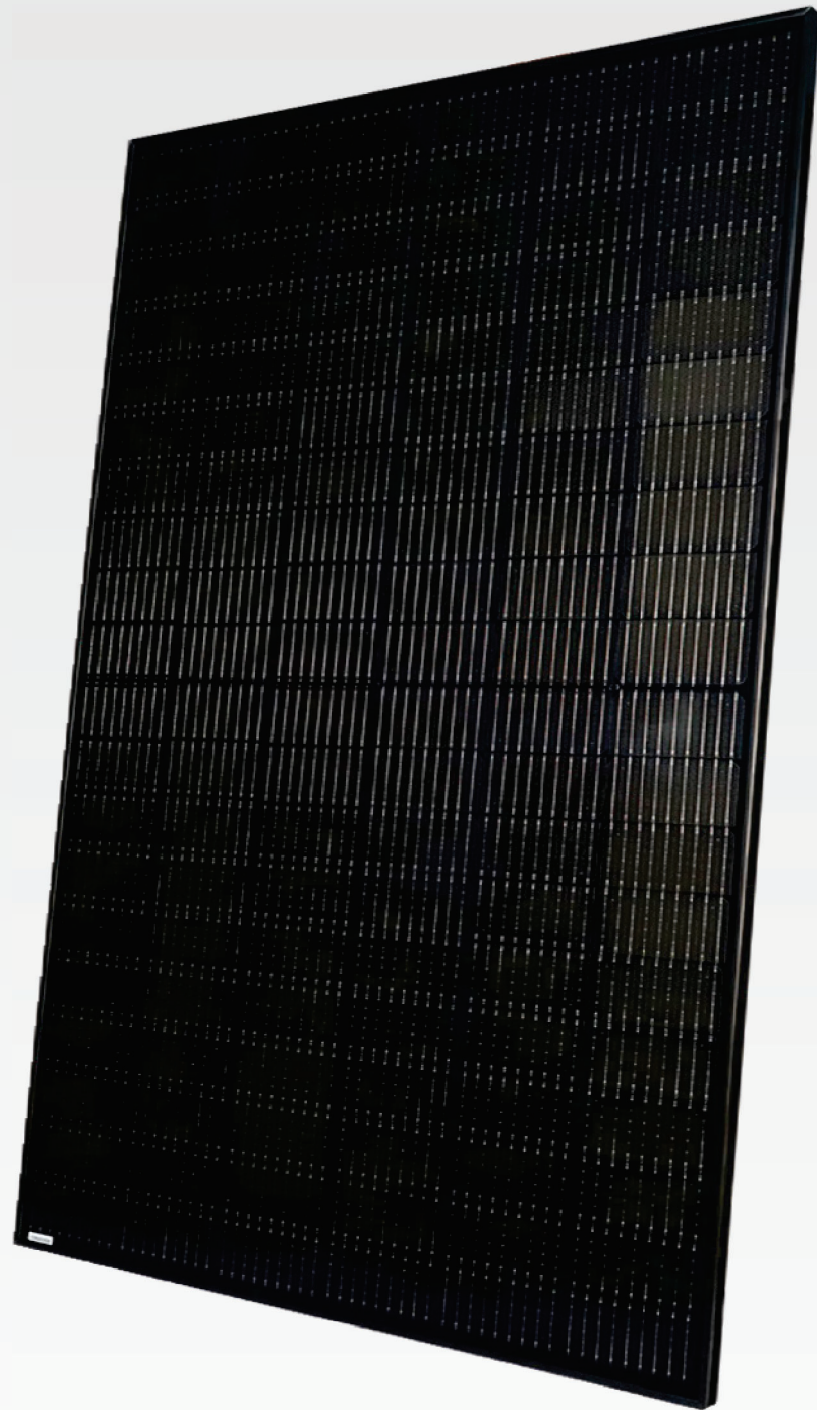

MODULE SPECIFICATIONS

ELECTRICAL CHARACTERISTICS

Characteristics	FF-MP-BBB-400
Maximum Power (P _{max})	400W
Maximum Power Voltage (V _{mp})	31.01V
Maximum Power Current (I _{mp})[A]	12.90A
Open Circuit Voltage (V _{oc})[V]	37.07V
Short Circuit Current (I _{sc})[A]	13.79A
Module Efficiency	20.48%
Power Tolerance	0/+5W
STC	Irradiance of 1000W/m ² , AM1.5, cell Temperature 25°C

FRAME PROFILE

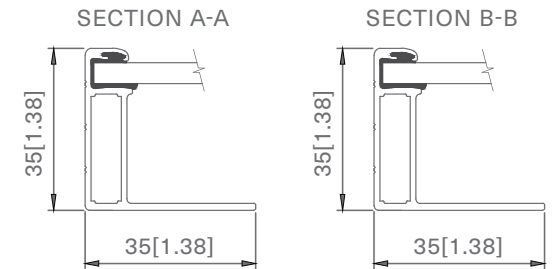

MECHANICAL CHARACTERISTICS

Cell Type	Mono perc, 182 mm-half cells, 108 (6x9+6x9)
Weight	22.1 kgs (48.7 lbs)
Dimension	1722 x 1134 x 35 mm (67.80 x 44.65 x 1.38)
Front Glass	3.2 mm (.13 in), High Transmission, Low Iron & Semi-Tempered Glass
Junction Box	IP68 (3 Bypass Diodes)
Output Cables	1200 mm (47 in)
Connector	Staubli EVO2
Frame & Installation	Anodized aluminum profile

OPERATIONS CHARACTERISTICS

Operational Temperature	-40°C~+85°
Max System Voltage	1500V
Max Series Fuse Rating	25A
Safety Class	Class II
Fire Rating	Type 1

MECHANICAL LOADING

Snow Load	5,400Pa (113lb/ft2)
Rear Side Design Load	2,400Pa (50lb/ft2)

PACKAGING INFORMATION

Container	20' GP	40' HC
Pallets per Container	6	26
Panels per Container	186	806

TEMPERATURE RATINGS

Temperature Coefficient of P _{max}	-0.350%/°C
Temperature Coefficient of V _{oc}	-0.275%/°C
Temperature Coefficient of I _{sc}	+0.045%/°C
Nominal Operating cell Temperature (NOCT)	42°C±2°C

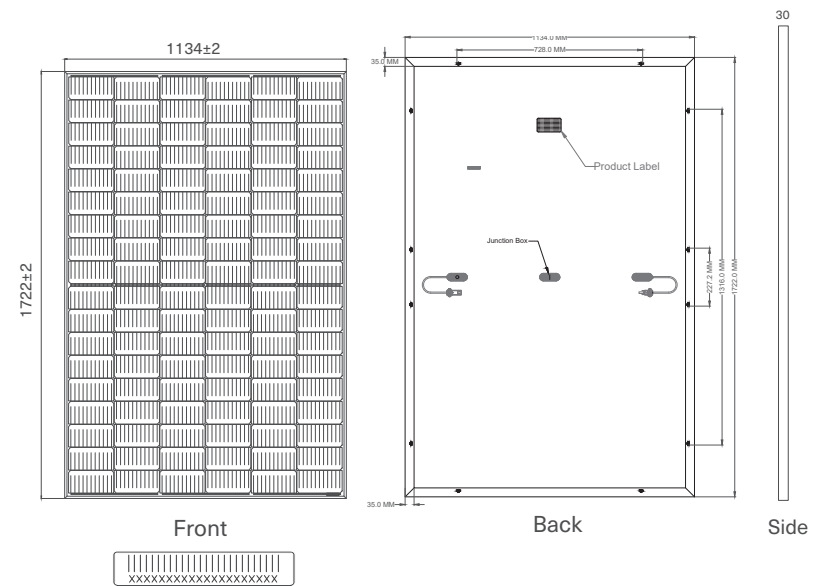

CURRENT-VOLTAGE CURVE

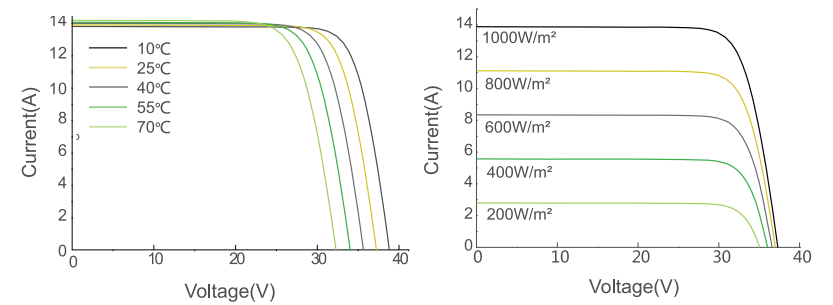

CERTIFICATIONS AND STANDARDS PENDING



UL 61730 | UL 61215 | ISO 9001 | ISO 14001



Power Optimizer

For North America

S440, S500



POWER OPTIMIZER

PV power optimization at the module level

- Specifically designed to work with SolarEdge residential inverters
- Detects abnormal PV connector behavior, preventing potential safety issues*
- Module-level voltage shutdown for installer and firefighter safety
- Superior efficiency (99.5%)
- Mitigates all types of module mismatch loss, from manufacturing tolerance to partial shading
- Faster installations with simplified cable management and easy assembly using a single bolt
- Flexible system design for maximum space utilization
- Compatible with bifacial PV modules
- Meets NEC requirements for arc fault protection (AFCI) and Photovoltaic Rapid Shutdown System (PVRSS)

* Expected availability in 2022

solaredge.com



Power Optimizer

For North America

S440, S500

	S440	S500	Unit
INPUT			
Rated Input DC Power ⁽¹⁾	440	500	W
Absolute Maximum Input Voltage (Voc)	60		Vdc
MPPT Operating Range	8 - 60		Vdc
Maximum Short Circuit Current (Isc) of Connected PV Module	14.5	15	Adc
Maximum Efficiency	99.5		%
Weighted Efficiency	98.6		%
Oversvoltage Category	II		
OUTPUT DURING OPERATION			
Maximum Output Current	15		Adc
Maximum Output Voltage	60		Vdc
OUTPUT DURING STANDBY (POWER OPTIMIZER DISCONNECTED FROM INVERTER OR INVERTER OFF)			
Safety Output Voltage per Power Optimizer	1+/-0.1		Vdc
STANDARD COMPLIANCE			
Photovoltaic Rapid Shutdown System	NEC 2014, 2017 & 2020		
EMC	FCC Part 15 Class B, IEC61000-6-2, IEC61000-6-3		
Safety	IEC62109-1 (class II safety), UL1741		
Material	UL94 V-0, UV Resistant		
RoHS	Yes		
Fire Safety	VDE-AR-E 2100-712:2013-05		
INSTALLATION SPECIFICATIONS			
Maximum Allowed System Voltage	1000		Vdc
Dimensions (W x L x H)	129 x 153 x 30 / 5.07 x 6.02 x 1.18		mm / in
Weight (including cables)	655 / 1.5		gr / lb
Input Connector	MC4 ⁽²⁾		
Input Wire Length	0.1 / 0.32		m / ft
Output Connector	MC4		
Output Wire Length	(+) 2.3, (-) 0.10 / (+) 7.54, (-) 0.32		m / ft
Operating Temperature Range ⁽³⁾	-40 to +85		°C
Protection Rating	IP68 / Type6B		
Relative Humidity	0 - 100		%

(1) Rated power of the module at STC will not exceed the power optimizer Rated Input DC Power. Modules with up to +5% power tolerance are allowed

(2) For other connector types please contact SolarEdge

(3) For ambient temperature above +70°C / +158°F power de-rating is applied. Refer to Power Optimizers Temperature De-Rating Technical Note for more details

PV System Design Using a SolarEdge Inverter	Single Phase HD-Wave	Three Phase for 208V grid	Three Phase for 277/480V grid	
Minimum String Length (Power Optimizers)	S440, S500	8	14	18
Maximum String Length (Power Optimizers)	25		50 ⁽⁴⁾	
Maximum Nominal Power per String	5700 (6000 with SE7600-US-SE11400-U)	6000	12750	W
Maximum Allowed Connected Power per String ⁽⁵⁾ (Permitted only when the difference in connected power between strings is 1,000W or less)	Refer to Footnote 5	One String 7200W Two strings or more 7800W	15,000W	
Parallel Strings of Different Lengths or Orientations	Y			

(4) A string with more than 30 optimizers does not meet NEC rapid shutdown requirements; safety voltage will be above the 30V requirement

(5) If the inverters rated AC power < maximum nominal power per string, then the maximum power per string will be able to reach up to the inverters maximum input DC power. Refer to: <https://www.solaredge.com/sites/default/files/se-power-optimizer-single-string-design-application-note.pdf>

(6) It is not allowed to mix S-series and P-series Power Optimizers in new installations

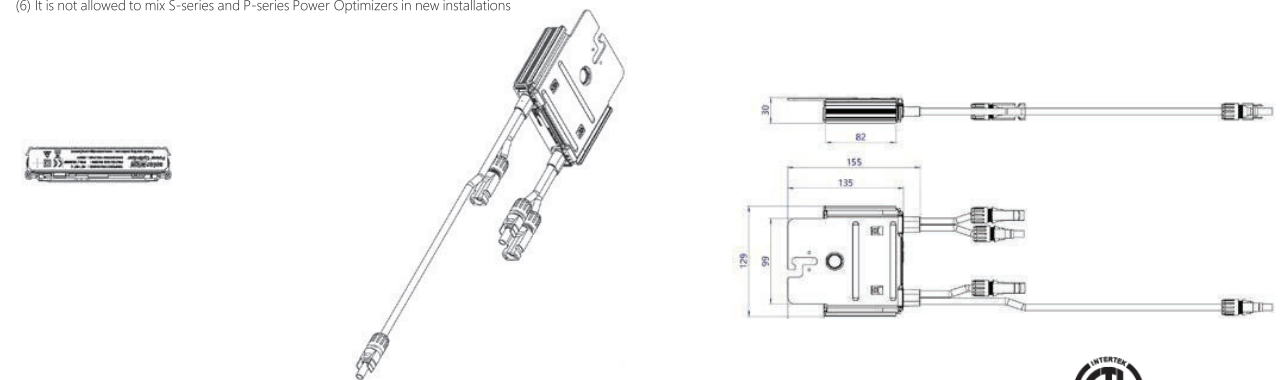

© SolarEdge Technologies, Inc. All rights reserved. SOLAREEDGE, the SolarEdge logo, OPTIMIZED BY SOLAREEDGE are trademarks or registered trademarks of SolarEdge Technologies, Inc. All other trademarks mentioned herein are trademarks of their respective owners. Date: February 8, 2022 DS-000018-NA. Subject to change without notice.



Single Phase Inverter with HD-Wave Technology for North America

SE3000H-US / SE3800H-US / SE5000H-US / SE6000H-US / SE7600H-US / SE10000H-US / SE11400H-US



12-25
YEAR
WARRANTY

INVERTERS

Optimized installation with HD-Wave technology

- Specifically designed to work with power optimizers
- Record-breaking 99% weighted efficiency
- Quick and easy inverter commissioning directly from a smartphone using the SolarEdge SetApp
- Fixed voltage inverter for longer strings
- Integrated arc fault protection and rapid shutdown for NEC 2014, NEC 2017 and NEC 2020 per article 690.11 and 690.12
- UL1741 SA certified, for CPUC Rule 21 grid compliance
- Small, lightweight, and easy to install both outdoors or indoors
- Built-in module-level monitoring
- Optional: Faster installations with built-in consumption metering (1% accuracy) and production revenue grade metering (0.5% accuracy, ANSI C12.20)

Single Phase Inverter with HD-Wave Technology for North America

SE3000H-US / SE3800H-US / SE5000H-US / SE6000H-US / SE7600H-US / SE10000H-US / SE11400H-US

MODEL NUMBER	SE3000H-US	SE3800H-US	SE5000H-US	SE6000H-US	SE7600H-US	SE10000H-US	SE11400H-US	
APPLICABLE TO INVERTERS WITH PART NUMBER	SEXXXXH-XXXXXBXX4							
OUTPUT								
Rated AC Power Output	3000	3800 @ 240V 3300 @ 208V	5000	6000 @ 240V 5000 @ 208V	7600	10000	11400 @ 240V 10000 @ 208V	VA
Maximum AC Power Output	3000	3800 @ 240V 3300 @ 208V	5000	6000 @ 240V 5000 @ 208V	7600	10000	11400 @ 240V 10000 @ 208V	VA
AC Output Voltage Min.-Nom.-Max. (211 - 240 - 264)	✓	✓	✓	✓	✓	✓	✓	Vac
AC Output Voltage Min.-Nom.-Max. (183 - 208 - 229)	-	✓	-	✓	-	-	✓	Vac
AC Frequency (Nominal)	59.3 - 60 - 60.5 ⁽¹⁾							Hz
Maximum Continuous Output Current @240V	12.5	16	21	25	32	42	47.5	A
Maximum Continuous Output Current @208V	-	16	-	24	-	-	48.5	A
Power Factor	1, Adjustable - 0.85 to 0.85							
GFDI Threshold	1							A
Utility Monitoring, Islanding Protection, Country Configurable Thresholds	Yes							
INPUT								
Maximum DC Power @240V	4650	5900	7750	9300	11800	15500	17650	W
Maximum DC Power @208V	-	5100	-	7750	-	-	15500	W
Transformer-less, Ungrounded	Yes							
Maximum Input Voltage	480							Vdc
Nominal DC Input Voltage	380							Vdc
Maximum Input Current @240V ⁽²⁾	8.5	10.5	13.5	16.5	20	27	30.5	Adc
Maximum Input Current @208V ⁽²⁾	-	9	-	13.5	-	-	27	Adc
Max. Input Short Circuit Current	45							Adc
Reverse-Polarity Protection	Yes							
Ground-Fault Isolation Detection	600k Ω Sensitivity							
Maximum Inverter Efficiency	99	99.2						%
CEC Weighted Efficiency	99						99 @ 240V 98.5 @ 208V	%
Nighttime Power Consumption	< 2.5							W

(1) For other regional settings please contact SolarEdge support

(2) A higher current source may be used; the inverter will limit its input current to the values stated

/ Single Phase Inverter with HD-Wave Technology

for North America

SE3000H-US / SE3800H-US / SE5000H-US / SE6000H-US/
SE7600H-US / SE10000H-US / SE11400H-US

MODEL NUMBER	SE3000H-US	SE3800H-US	SE5000H-US	SE6000H-US	SE7600H-US	SE10000H-US	SE11400H-US
ADDITIONAL FEATURES							
Supported Communication Interfaces	RS485, Ethernet, ZigBee (optional), Cellular (optional)						
Revenue Grade Metering, ANSI C12.20	Optional ⁽³⁾						
Consumption metering							
Inverter Commissioning	With the SetApp mobile application using Built-in Wi-Fi Access Point for Local Connection						
Rapid Shutdown - NEC 2014, NEC 2017 and NEC 2020, 690.12	Automatic Rapid Shutdown upon AC Grid Disconnect						
STANDARD COMPLIANCE							
Safety	UL1741, UL1741 SA, UL1699B, CSA C22.2, Canadian AFCI according to T.I.L. M-07						
Grid Connection Standards	IEEE1547, Rule 21, Rule 14 (HI)						
Emissions	FCC Part 15 Class B						
INSTALLATION SPECIFICATIONS							
AC Output Conduit Size / AWG Range	1" Maximum / 14-6 AWG			1" Maximum / 14-4 AWG			
DC Input Conduit Size / # of Strings / AWG Range	1" Maximum / 1-2 strings / 14-6 AWG			1" Maximum / 1-3 strings / 14-6 AWG			
Dimensions with Safety Switch (HxWxD)	17.7 x 14.6 x 6.8 / 450 x 370 x 174			21.3 x 14.6 x 7.3 / 540 x 370 x 185			
Weight with Safety Switch	22 / 10	25.1 / 11.4	26.2 / 11.9	38.8 / 17.6			
Noise	< 25			< 50			
Cooling	Natural Convection						
Operating Temperature Range	-40 to +140 / -40 to +60 ⁽⁴⁾						
Protection Rating	NEMA 4X (Inverter with Safety Switch)						

(3) Inverter with Revenue Grade Meter P/N: SExxxxH-US000BNC4; Inverter with Revenue Grade Production and Consumption Meter P/N: SExxxxH-US000BNI4. For consumption metering, current transformers should be ordered separately: SEACT0750-200NA-20 or SEACT0750-400NA-20. 20 units per box

(4) Full power up to at least 50°C / 122°F; for power de-rating information refer to: <https://www.solaredge.com/sites/default/files/se-temperature-derating-note-na.pdf>

How to Enable Consumption Monitoring

By simply wiring current transformers through the inverter's existing AC conduits and connecting them to the service panel, homeowners will gain full insight into their household energy usage helping them to avoid high electricity bills

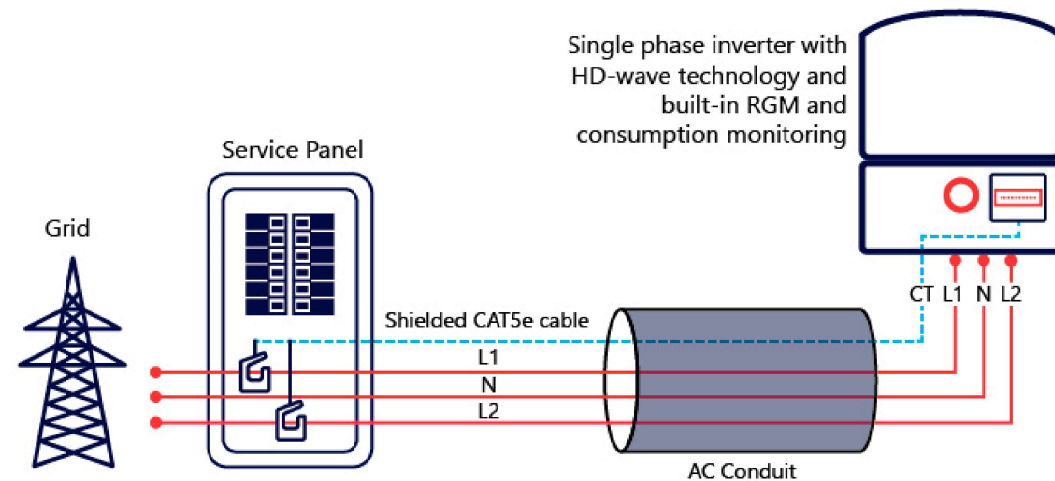

pe.eaton.com

Eaton general duty non-fusible safety switch

DG222URB

UPC:782113144238

Dimensions:

- **Height:** 14.38 IN
- **Length:** 7.38 IN
- **Width:** 8.69 IN

Weight:9 LB

Notes:WARNING! Switch is not approved for service entrance unless a neutral kit is installed.

Warranties:

- Eaton Selling Policy 25-000, one (1) year from the date of installation of the Product or eighteen (18) months from the date of shipment of the Product, whichever occurs first.

Specifications:

- **Type:** Non-fusible, single-throw
- **Amperage Rating:** 60A
- **Enclosure:** NEMA 3R, Rainproof
- **Enclosure Material:** Painted galvanized steel
- **Fuse Configuration:** Non-fusible
- **Number Of Poles:** Two-pole
- **Number Of Wires:** Two-wire
- **Product Category:** General duty safety switch
- **Voltage Rating:** 240V

Supporting documents:

- [Eatons Volume 2-Commercial Distribution](#)
- [Eaton Specification Sheet - DG222URB](#)

Certifications:

- UL Listed

Product compliance: No Data





ROCKIT

COMPLETE RAIL-LESS RACKING SYSTEM

The RockIt system is the industry's premier rail-less PV racking system for composition shingle, tile, and metal roofs. Designed in conjunction with the needs of installers, RockIt quickly & easily installs with a single tool. Featuring an easy-to-position alignment slide and a top-down leveling system, RockIt is logistically intelligent with no need to ship or transport long rails. Components are available in a black finish that complements both commercial and residential applications. Conforms to UL 2703.

FEATURES & BENEFITS

- Patented watertight technology
- Fully integrated bonding
- Top-down leveling system
- North-South adjustability
- Single tool install

STREAMLINED INSTALLATION WITH MINIMAL ROOF PENETRATIONS



ROCKIT

COUPLING

The fast installing RockIt Coupling easily attaches to the module frame to bridge the gaps between modules.

SKIRT

The sleek black Skirt installs first and acts as an alignment guide for the entire array. The Skirt End Cap does double duty as a skirt coupling device and an aesthetically-pleasing finishing touch.

ROCKIT MOUNT

Featuring integrated bonding pins, the RockIt Mount connects to the Slide and can easily be positioned for fast installation. Features top-down leveling.

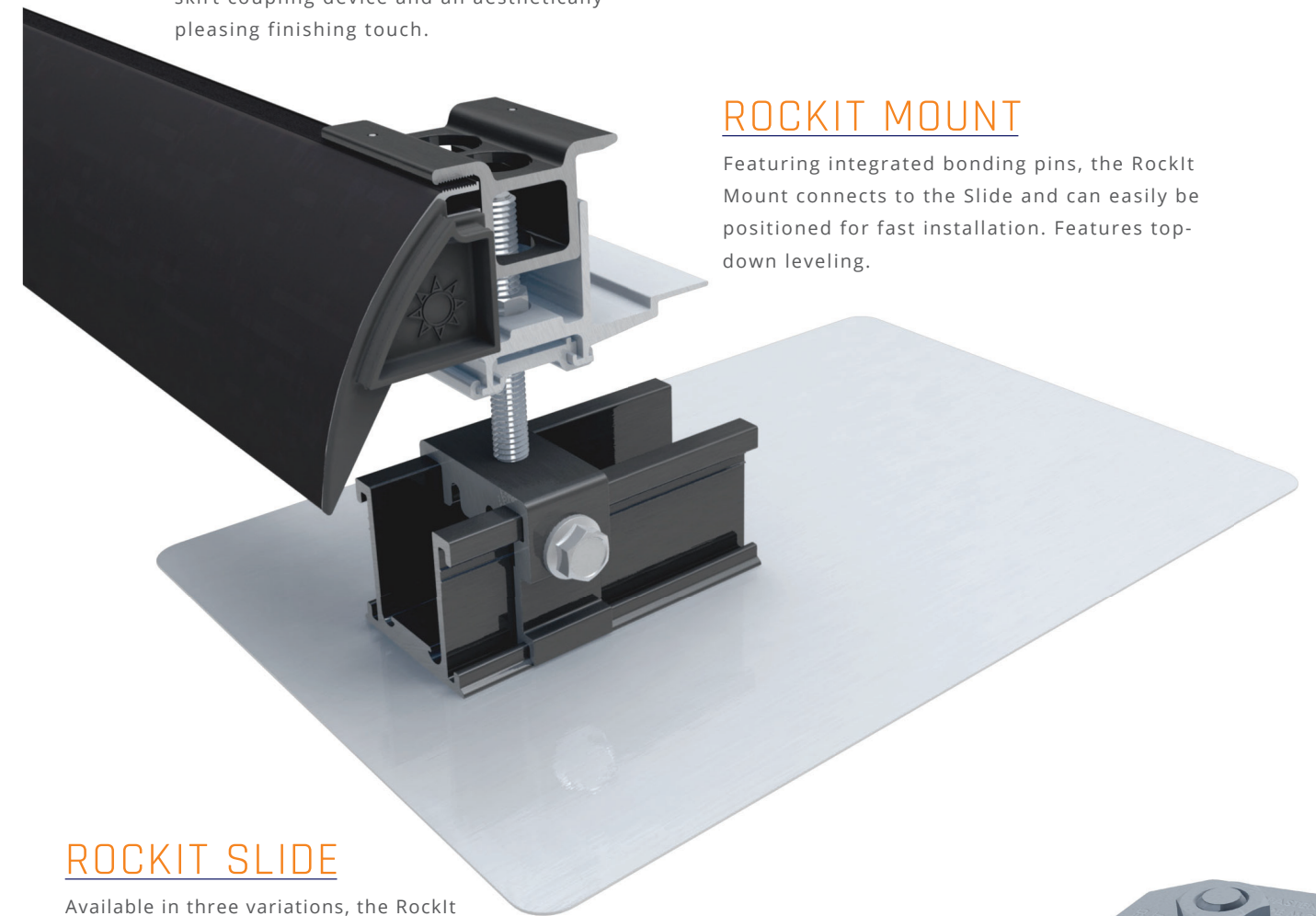

ROCKIT SLIDE

Available in three variations, the RockIt Slide allows installation on composition shingle, tile, and metal roofs.

FRAME MLPE MOUNT

Attaches and fully bonds MLPE's (Module Level Power Electronics) to the module frame with a single bolt clip.

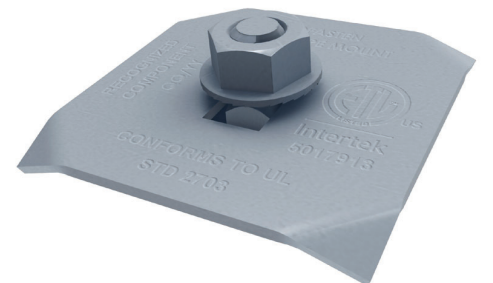

COMPATIBLE MODULES

The Rockit System has been tested and evaluated to UL 2703 for bonding, grounding, mechanical loading and fire classification, and may be used to ground and/or mount PV modules listed to UL 1703 or UL 61730. A list of approved modules is included below.

Unless otherwise noted, “xxx” refers to the module power rating and both black and silver frames are included in the certification.

*Class A System fire rating with Type 1, 2, and 29 PV modules with no skirt required.

NOTE: Modules with flange widths shorter than 22mm cannot be installed in portrait.

TYPE 1, 2 & 29 MODULES

MANUFACTURER	LIST OF UL 2703 APPROVED TYPE 1, 2 & 29 PV MODULES*
Adani	Adani modules with 35 and 40mm frames ASX-Y-ZZ-xxx Where “X” can be B, M or P, “Y” can be 6 or 7, and “ZZ” can be blank, PERC, B-PERC, or AB-PERC
AIONRISE	Aionrise modules with 35 and 40mm frames AIONyyG1-xxx Where “yy” can be 60 or 72
Aptos Solar	Aptos modules with 35 and 40 mm frames DNA-yy-zzaa-xxx Where “yy” can be 108, 120 or 144; “zz” can be MF or BF; and “aa” can be 10, 23 or 26
Astronergy Solar	Astronergy modules with 35 and 40 mm frames CHSMbbyC/zz-xxx Where “bb” can be 60, 66, or 72; “yy” can be blank, 10 or 12; “C” can be M, M(BL), M-HC, P, P(BL) or P-HC ; and “zz” can be blank or HV
Auxin	Auxin modules with 40 mm frames AXN6M6YYMxxxZ Where “YY” can be 10 or 12; “Z” can be blank, A, B or C
Axitec	Axitec Modules with 30 and 35 mm frames AC-xxxY/aaZZ “Y” can be M, P, MH or MBT; and “aa” can be blank, 125 or 156; and “ZZ” can be 60S, 108V, 108VB, 120S, 120V or 120VB

MANUFACTURER	LIST OF UL 2703 APPROVED TYPE 1, 2 & 29 PV MODULES*
Bluesun Solar	Bluesun modules with 30 and 35mm frames BSMxxxM-AAA Where “AAA” can be 60HPH or 72HBD
Boviet	Boviet modules with 35 and 40mm frames BVM66aaYY-xxxBcc Where “aa” can be 9, 10 or 12; “YY” is M, or P; and “B” can be blank, L or S; and “cc” can be blank, H, H-BF, H-HC or HC-BF
Canadian Solar	Canadian Solar modules with 35 and 40 mm frames CSbY-xxxZ Where “b” can be 1, 3 or 6; “Y” can be H, K, L, N, P, R, V or Y; and “Z” can be M, MS, M-SD, MS-HL, MS-SD, P, PX, or P-SD
CertainTeed	CertainTeed modules with 35 and 40mm frames CTxxxYZZ-AA Where “Y” can be M, HC; “ZZ” can be 00, 10, 11; and “AA” can be 04 or 06
CSUN	CSUN modules with 35 and 40 mm frames CSUNxxx-zzAbb Where “zz” is 60 or 72; and “A” is M or MM; “bb” is blank or 5BB
Dehui	Dehui modules with 35 and 40mm frames DH-MYYYY-xxx Where “YYY” can be 760, 772, 860, 872; and “Z” can be B or W
ET Solar	ET Solar modules with 35 and 40mm frames ET-YZZZxxxAA Where “Y” can be P, L, or M; “ZZZ” can be 660, 660BH, 672, 672BH, or 754BH; and “AA” can be TB, TW, WB, WW, BB, WBG, WWG, WBAC, WBCO, WWCO, WWBCO or BBAC
Freedom Forever	Freedom Forever modules with 35mm frames FF-MPa-BBB-xxx Where “a” can be blank or 1
Freevolt	Freevolt modules with 35mm frames ECP-PVGRAF-144HC-xxx

MANUFACTURER	LIST OF UL 2703 APPROVED TYPE 1, 2 & 29 PV MODULES*
Hanwha Q CELLS	Hanwha Q CELLS Modules with 32, 35 and 40mm frames aaYY-ZZ-xxx where "aa" can be Q, or B.; "YY" can be PLUS, PRO, PEAK, LINE PRO, LINE PLUS, PLUS DUO or PEAK DUO; and "ZZ" can be G3, G3.1, G4, G4.1, L-G2, L-G2.3, L-G3, L-G3.1, L-G3y, L-G4, L-G4.2, L-G4y, LG4.2/TAA, BFR-G3, BLK-G3, BFR-G3.1, BLK-G3.1, BFR-G4, BFR-G4.1, BFR G4.3, BLK-G4.1, G4/SC, G4.1/SC, G4.1/TAA, G4.1/MAX, BFR G4.1/TAA, BFR G4.1/MAX, BLK G4.1/TAA, BLK G4.1/SC, EC-G4.4, G5, G5/SC, G5/TS, BLK-G5, BLK-G5/SC, BLK-G5/TS, L-G5, L-G5.1, L-G5.2, L-G5.2/H, L-G5.3, G6, G6/SC, G6/TS, G6+, G6+/TS, BLK-G6, G7, BLK-G6+, BLK-G6+/AC, BLK-G6+/HL, BLK-G6+/SC, BLK-G6/TS, BLK-G6+/TS, BLK-G7, G7.2, G8, BLK-G8, G8+, BLK-G8+ L-G7, L-G7.1, L-G7.2, L-G7.3, BLK ML-G9, ML-G9+, BLK ML-G9+, ML-G9, BLK-G10+, BLK-G10+/AC, ML-G10, BLK ML-G10, ML-G10+, BLK ML-G10+, ML-G10.a, BLK ML-G10.a+ or BLK ML-G10.a+
Heliene	Heliene modules with 35 and 40 mm frames YYZZxxxxA Where "YY" can be 60, 72, 108 or 120; "ZZ" can be HC, M or P; and "A" can be blank, M10-SL, M10-SL-BLK or M10-SL-Bifacial
HT-SAAE	HT-SAAE modules with 35 and 40 mm frames HTyy-aaaZ-xxx Where "yy" can be 60 or 72, "aaa" can be 156 or 166, "Z" can be M, M(V), M(S), M(VS), M-C, M(V)-C, P or P(V)
Hyperion	Hyperion modules with 35mm frames HY-DH108P8-xxx
Hyundai	Huyn dai modules with 32, 35 and 40 mm frames HiY-SxxxZZ Where "Y" can be A or S; "S" can be M or S; and "ZZ" can be HG, KI, MF, MG, PI, SG, RG, RG (BK), TG or YH(BK) or XG(BK)
Itek	Itek Modules with 40 mm frames IT-xxx-YY "YY" can be blank, HE, or SE
JA Solar	JA Solar modules with 30, 35 and 40mm frames JAyyzz-bbwww-xxx/aa Where "yy" can be M, P, M6 or P6; "zz" can be blank, (K), (L), (R), (V), (BK), (FA), (SE), (TG), (FA)(R), (K)(SE), (K)(TG), (L)(BK), (L)(TG), (R)(BK), (R)(TG), (V)(BK), (BK)(TG), or (L)(BK)(TG); "bb" can be 54, 60 or 72; "www" can be blank, D30, S01, S02, S03, S09, S10, S17, S30 or S31; and "aa" can be MR, SI, SC, PR, RE, 3BB, 4BB, 4BB/RE, 4BB/1500V, PR/1500V, 5BB

MANUFACTURER	LIST OF UL 2703 APPROVED TYPE 1, 2 & 29 PV MODULES*
Jinko	Jinko modules with 35 and 40 mm frames JKMYxxxZZ-aa Where "Y" can either be blank or S; "ZZ" can be M, P, PP, or -V; and "aa" can be blank, 60, 60B, 60H, 60HB, 60L, 60BL, 60HL, 60HBL, 60-J4, 60B-J4, 60B-EP, 60(Plus), 60-V, 60-MX, 72H, 72H-V, 72HL-V, 72HBL-V, 72L-V, 6RL3, 6RL3-B or 6TL3-B
LG	LG modules with 40mm frames LGxxxzyz-bb "y" can be A, E, M, N, Q, or S; "a" can be A, 1, 2 or 3; "z" can be C, K or W; and "bb" can be G4, A5, A6, B6, E6, E6.AW5, L5, N5, v5, V6
Longi	Longi modules with 35 and 40 mm frames LRa-YYZZ-xxxM Where "a" can be 4, 5 or 6; "YY" can be 54, 60 or 66 "ZZ" can be blank, BK, PB, PE, PH, HPB, or HPH
Maxeon	Maxeon modules with 35, 40 and 46mm frames SPR-AAAY-xxx-zzz Where "AAA" can be MAX or X; "Y" can be 3, 5, 6, 21 or 22; and "zzz" can be R, BLK or COM
Meyer Burger	Meyer Burger Modules with 35mm frames Meyer Burger Glass
Mission Solar	Mission Solar modules with 35, 40 mm frames YYYbb-xxxZZaa Where "YYY" can be MSE or TXS; "bb" can be blank, 6 or 60A; "ZZ" can be blank, SO, SQ, SX, 120 or 144; and "aa" can be blank, BB, BW, 4J, 4S, 5K, 5R, 5T, 8T, 8K, 9R or 9Z
Next Energy Alliance	Next Energy Alliance modules with 35 and 40mm frames yyNEA-xxxZZ where "yy" can be blank or US; "ZZ" can be M, MB or M-60
NE Solar	NE Solar modules with 30, 35 and 40mm frames NESExxx-zzMH-yy Where "zz" can be 54 or 60; and "yy" can be M6 or M10
Panasonic (HIT)	Panasonic modules with 40 mm frames VBHNxxxYYzzA "YY" can be either SA or KA; "zz" can be either 03, 04, 17 or 18; and "A" can be blank, E or G

MANUFACTURER	LIST OF UL 2703 APPROVED TYPE 1, 2 & 29 PV MODULES*
Panasonic (EverVolt)	Panasonic modules with 30 mm frames EVPVxxxA Where "A" can be blank or H, K or PK
Philadelphia Solar	Philadelphia modules with 35 and 40 mm frames PS-YzzAA-xxx Where "Y" can be M or P; "zz" can be 60, 72 or 144; and "AA" can be blank, (BF), (HC) or (HCBF)
Phono Solar	Phono Solar modules with 30 and 35 mm frames PSxxxY-ZZ/A Where "Y" can be M4, M4H, M5GF, M5GFH, M6, M6H, M8GF or M8GFH; "ZZ" can be 18, 20 or 24; and "A" can be TH, UHB, VH or VHB
Prism Solar	Prism Solar modules with 35mm frames PST-xxxW-M72Y Where "Y" can be H, HB or HBI
REC	REC modules with 30 and 38 mm frames RECxxxYYZZ Where "YY" can be AA, M, NP, NP2, PE, PE72, TP, TP2, TP2M, TP2SM, TP2S, TP3M or TP4; and "ZZ" can be blank, Black, BLK, BLK2, SLV, 72, Pure or Pure-R
Recom	Recom modules with 35 and 40 mm frames RCM-xxx-6yy Where "yy" can be MA, MB, ME or MF
Renesola	ReneSola 60-cell modules with 40 mm frames JCxxxY-ZZ "Y" can be F, M or S; and "ZZ" can be Ab, Ab-b, Abh, Abh-b, Abv, Abv-b, Bb, Bb-b, Bbh, Bbh-b, Bbv, Bbv-b, Db, or Db-b
S-Energy	S-Energy modules with 35 and 40mm frames SABB-CCYY-xxxZ Where "A" can be C, L or N; "BB" can be blank, 20, 40 or 45; "CC" can be blank, 60 or 72; "YY" can be blank, MAE, MAI, MBE, MBI, MCE or MCI; and "Z" can be V, M-10, P-10 or P-15
Seraphim USA	Seraphim modules with 35 and 40 mm frames SRP-xxx-YYY-ZZ Where "YYY" can be 6MA, 6MB, 6PA, 6PB, or BMD; "ZZ" is blank or HV

MODULES

MANUFACTURER	LIST OF UL 2703 APPROVED TYPE 1, 2 & 29 PV MODULES*
SEG Solar	SEG Solar Modules with 35 and 40mm frames SEG-xxx-YYY-ZZ Where "YYY" can be BMB, BMD or 6MA; "ZZ" can be BB, BW, HV, TB, WB or WW
Shinsung E&G	Shinsung Modules with 35mm frames SSVxxx-144MH
Silfab	Silfab Modules with 35 and 38 mm frames SY-Y-Z-xxxAb Where "YY" can be IL, SA, LA, SG or LG; "Z" can be blank, M, P, or X; "A" can be blank, B, H, M, N; and "b" can be A, C, C+, G, K, L, N, T, U or X
Solar4America	Solar4America modules with 35 and 40mm frames S4Axxx-72yy Where "yy" can be MH5 or MH5BB
Solarever	Solarever modules with 35mm frames SE-zzz*yy-xxxM-aaa Where "zzz" can be 166 or 182; "yy" can be 83 or 91; and "aaa" can be 108 or 144
Solaria	Solaria modules with 35 and 40 mm frames PowerA-xxxR-ZZ Where "A" can be XT or X; and "ZZ" can be blank, AC, BD, BX, BY, PD, PL, PX, PZ, WX or WZ
SolarTech	SolarTech modules with 40 mm frames AAA-xxx Where "AAA" can be PERCB-B, PERCB-W, HJTb-B or HJTb-W
Sonali	Sonali Modules with 35mm frames SS-M-xxx
Star Solar	Star Solar modules with 35mm frames Star-xxxYYY-ZZZ Where "YYY" can be M60H or M60HB; and "ZZZ" can be blank or M10
Sunmac Solar	Sunmac modules with 30 and 35mm frames SMxxxMaaaZZ-BB Where "aaa" can be 660 or 754; and "ZZ" can be NH or SH
Sunpower	Sunpower modules with 35 and 40 mm frames SPR-A-xxx-YY Where "A" can be A or M; and "YY" can be blank, COM, G-AC, BLK-G-AC, H-AC or BLK-H-AC
Sunpreme	Sunpreme Modules with 40mm frames GxB-xxxT

MODULES

MANUFACTURER	LIST OF UL 2703 APPROVED TYPE 1, 2 & 29 PV MODULES*
Sunspark	Sunspark modules with 40 mm frames SYY-xxxZ-A Where "YY" can be MX or ST; and "Z" can be M, MB, M3, M3B, P or W; and "A" can be 60 or 72
Suntech	Suntech Modules with 35mm frames STPxxxS-zz/aa Where "zz" can be B60 or B72; and "aa" can be Vnh or Wnhb
Talesun	Talesun modules with 30mm frames TD6y72M-xxx Where "y" can be G or I
Tesla	Tesla modules with 40 mm frames TxxxY Where "Y" can be H or S
Trina	Trina modules with 30, 35 and 40 mm frames TSM-xxxYYZZ "YY" can be DD05, DD05A, DD06, DE05, DE09, DX05A, DE06X, PA05, PC05, PD05, PE14 or PX05; and "ZZ" can be blank or A, .05, .05(II), .08, A.05, A.08, A(II), A.05(II), A.08(II), C.05, C.07, C.05(II), C.07(II), H, H.05, H.08, H.05(II), H.08(II), M, M(II) or M.05(II)
Universal	Universal Solar Modules with 35mm frames UNI-xxx-yyyZZZ-aa Where "yyy" can be 108, 120 or 144; "ZZZ" can be M, MH or BMH; and "aa" can be blank, BB or DG
URE	URE modules with 35 mm frames DyMxxaa Where "D" can be D or F, "y" can be A, B, 6 or 7; "M" can be K or M; and "aa" can be C8G, H3A, H4A, H8A, E7G-BB or MFG-BB
Vikram	Vikram solar modules with 35 and 40 mm frames XVSyy.ZZ.AAA.bb Where "X" can be blank, Paradea, Prexos or Somera; "yy" can be MDH, MDHT, MH or MHBB; "ZZ" can be 60 or 72; "AAA" is the module power rating; and "bb" can be 05
VSUN	VSUN modules with 30, 35 and 40 mm frames VSUNxxx-YYz-aa Where "YY" can be 108 or 120; "z" can be BMH or M; and "aa" can be blank, BB or BW
Waaree	Waaree modules with 40mm frames WSyy-xxx where "yy" can be blank, M or MB

MANUFACTURER	LIST OF UL 2703 APPROVED TYPE 1, 2 & 29 PV MODULES*
Yingli	Yingli modules with 35 and 40 mm frames YLxxxZ-yy Where "Z" can be D or P; "yy" can be 29b, 30b, 34d, 35b, 36b or 40d
Yotta	Yotta modules with 30mm frames YSM-Bxxx-06-72-1
Zeus	Zeus Solar Modules with 40mm frames ZxxxM-HB
ZN Shine	ZN Shine modules with 35mm frames ZXM6-AAA-xxx/M Where "AAA" can be 72, NH120 or NHDB144

TYPE 4 & 5 MODULES

**Class A System fire rating with Type 4 and 5 modules with south edge skirt required. Class B System fire rating with Type 4 and 5 modules, no skirt required. Any roof-to-module gap is permitted. This rating is applicable with any roof attachment.

MANUFACTURER	LIST OF UL 2703 APPROVED TYPE 4, & 5 PV MODULES**
Bluesun Solar	Bluesun modules with 35mm frames BSMxxxM10-54HPH
Meyer Burger	Meyer Burger Modules with 35mm frames Meyer Burger Black or White
Talesun	Talesun modules with 30mm frames TP7G54M(H)xxx



May 16, 2022

EcoFasten Solar LLC
4141 W Van Buren St, Ste 2
Phoenix, AZ 85009
TEL: (877) 859-3947

Attn.: Eco Fasten Solar LLC - Engineering Department

Re: Report # 2015-05884HG.07.01 – EcoFasten - RockIt System for Gable and Hip Roofs
Subject: Engineering Certification for the State of North Carolina

PZSE, Inc. – Structural Engineers has provided engineering and span tables for the EcoFasten - RockIt System, as presented in PZSE Report # 2015-05884HG.07.01, "Engineering Certification for the EcoFasten - RockIt System for Gable and Hip Roofs". All information, data, and analysis therein are based on, and comply with, the following building codes and typical specifications:

- Building Codes:
1. ASCE/SEI 7-10, 7-16, Minimum Design Loads for Buildings and Other Structures, by American Society of Civil Engineers
 2. 2015 & 2018 International Building Code
 3. 2015 & 2018 International Residential Code
 4. AC428, Acceptance Criteria for Modular Framing Systems Used to Support Photovoltaic (PV) Panels, November 1, 2012 by ICC-ES
 5. Aluminum Design Manual 2015 & 2018, by The Aluminum Association, Inc.
 6. ANSI/AWC NDS-2015 & 2018, National Design Specification for Wood Construction, by the American Wood Council

Design Criteria:

Risk Category II
Seismic Design Category = A - E
Exposure Category = B, C & D
Basic Wind Speed (ultimate) per ASCE 7-16 = 90 mph to 180 mph
Ground Snow Load = 0 to 60 (psf)

This letter certifies that the loading criteria and design basis for the EcoFasten - RockIt System Span Tables are in compliance with the above codes.

If you have any questions on the above, do not hesitate to call.

Prepared by:
PZSE, Inc. – Structural Engineers
Roseville, CA

DIGITALLY SIGNED

