

EQUIPMENT LABELS

SOLAR PV SYSTEM EQUIPPED WITH RAPID SHUTDOWN

TURN RAPID SHUTDOWN SWITCH TO THE "OFF" POSITION TO SHUT DOWN PV SYSTEM AND REDUCE SHOCK HAZARD IN THE ARRAY

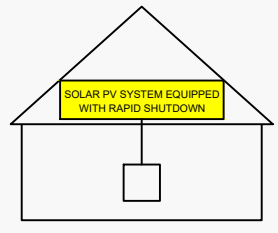

NEC 690.56 (C)(1)(a)
PLACE WITHIN 3FT OF SERVICE DISCONNECTING MEANS TO WHICH THE PV SYSTEMS ARE CONNECTED AND SHALL INDICATE THE LOCATIONS OF RAPID SHUTDOWN SWITCHES

PV SYSTEM DISCONNECT

NEC 690.13 (B)
PLACE ON PV SYSTEM DISCONNECTING MEANS.

⚠ WARNING

DUAL POWER SUPPLY

SOURCES: UTILITY GRID AND PV SOLAR ELECTRIC SYSTEM

NEC 705.12 (B)(3)
PLACE ON ALL EQUIPMENT THAT IS SUPPLIED BY BOTH POWER SOURCES

⚠ WARNING

ELECTRIC SHOCK HAZARD

TERMINALS ON THE LINE AND LOAD SIDES MAY BE ENERGIZED IN THE OPEN POSITION

NEC 690.13 (B)
PLACE ON PV SYSTEM DISCONNECTING MEANS.

⚠ WARNING

POWER SOURCE OUTPUT CONNECTION DO NOT RELOCATE THIS OVERCURRENT DEVICE

NEC 705.12 (B)(2)(3)(b)
PLACE ADJACENT TO BACK-FED BREAKER

WARNING: PHOTOVOLTAIC POWER SOURCE

NEC 690.31 (G)(3)&(4)
PLACE ON ALL JUNCTION BOXES, EXPOSED RACEWAYS, AND OTHER WIRING METHODS EVERY 10' AND ON EVERY SECTION SEPARATED BY ENCLOSURES, WALLS, PARTITIONS, CEILINGS, OR FLOORS.

⚠ WARNING

FED BY MULTIPLE POWER SOURCES

TOTAL RATING OF ALL OVERCURRENT DEVICES EXCLUDING UTILITY OVERCURRENT DEVICE SHALL NOT EXCEED AMPACITY OF BUSBAR

NEC 705.12 (B)(2)(3)(c)
PLACE ADJACENT TO BACK-FED BREAKER

DIRECT CURRENT PHOTOVOLTAIC POWER SOURCE

MAXIMUM VOLTAGE 600 VDC
MAX CIR. CURRENT 45 AMPS

NEC 690.53
PLACE ON ALL DC DISCONNECTING MEANS

PHOTOVOLTAIC POWER SOURCE

OPERATING AC VOLT. 240 VAC
MAXIMUM OPERATING AC OUTPUT CURRENT 42 AMPS

NEC 690.54
PLACE ON INTERCONNECTION DISCONNECTING MEANS

RAPID SHUTDOWN SWITCH FOR SOLAR PV SYSTEM

NEC 690.56 (C)(3)
PLACE ON RAPID SHUTDOWN SWITCH OR EQUIPMENT WITH INTEGRATED RAPID SHUTDOWN *REFLECTIVE*

EQUIPMENT LABEL NOTES

1. LABELS SHOWN ARE 1/2 THEIR ACTUAL REQUIRED SIZE.
2. LABEL MATERIAL SHALL BE SUITABLE FOR THE EQUIPMENT ENVIRONMENT.
3. CONDUIT SHALL BE MARKED WITH REQUIRED LABEL EVERY 10 FEET.

CONSTRUCTION NOTES

1. ALL WORK AND EQUIPMENT SHALL BE INSTALLED IN ACCORDANCE WITH THE LATEST NATIONAL, STATE, AND LOCAL CODES AND ORDINANCES
2. FOLLOW MANUFACTURER'S INSTALLATION INSTRUCTIONS, BEST PRACTICES, AND SPECIFICATIONS
3. WIRES SHALL BE RATED AND LABELED "SUNLIGHT RESISTANT" WHERE EXPOSED TO AMBIENT CONDITIONS
4. THE PHOTOVOLTAIC SYSTEM SHALL NOT EXCEED 600 VOLTS OR 800 AMPS
5. EACH ELECTRICAL APPLIANCE SHALL BE PROVIDED WITH A NAMEPLATE GIVING THE IDENTIFYING NAME AND THE RATING IN VOLTS AND AMPERES, OR VOLTS AND WATTS. IF THE APPLIANCE IS TO BE USED ON A SPECIFIC FREQUENCY OR FREQUENCIES, IT SHALL BE SO MARKED. WHERE MOTOR OVERLOAD PROTECTION EXTERNAL TO THE APPLIANCES IS REQUIRED, THE APPLIANCE SHALL BE SO MARKED
6. WHERE APPLICABLE, GROUNDING ELECTRODE CONDUCTOR TO BE CONTINUOUS. GROUNDING CRIMPS TO BE IRREVERSIBLE
7. IN ONE- AND TWO-FAMILY DWELLINGS, LIVE PARTS IN PHOTOVOLTAIC SOURCE CIRCUITS AND PHOTOVOLTAIC OUTPUT CIRCUITS OVER 150 VOLTS TO GROUND, SHALL ONLY BE ACCESSIBLE TO QUALIFIED PERSONS WHILE ENERGIZED.
8. PHOTOVOLTAIC SYSTEMS SHALL BE PERMANENTLY MARKED AT VARIOUS EQUIPMENT LOCATIONS TO IDENTIFY THAT A PHOTOVOLTAIC SYSTEM IS INSTALLED AND THAT VARIOUS DANGERS ARE PRESENT.
9. EACH PHOTOVOLTAIC SYSTEM DISCONNECTING MEANS SHALL BE PERMANENTLY MARKED TO IDENTIFY IT AS A PHOTOVOLTAIC SYSTEM DISCONNECT
10. WHERE ALL TERMINALS OF A DISCONNECTING MEANS MAY BE ENERGIZED IN THE OPEN POSITION, A WARNING SIGN SHALL BE MOUNTED ON OR ADJACENT TO THE DISCONNECT
11. A PERMANENT LABEL FOR THE DIRECT-CURRENT PHOTOVOLTAIC POWER SOURCE SHALL BE PROVIDED BY THE INSTALLED AT THE DC DISCONNECT MEANS
12. A PERMANENT PLAQUE OR DIRECTORY, DENOTING ALL ELECTRIC POWER SOURCES SERVING THE PREMISES, SHALL BE INSTALLED AT EACH SERVICE EQUIPMENT LOCATION AND AT LOCATIONS OF ALL POWER PRODUCTION SOURCES.
13. A PERMANENT PLAQUE OR DIRECTORY SHALL BE PROVIDED DENOTING THE LOCATIONS OF THE SERVICE DISCONNECT MEANS AND THE PHOTOVOLTAIC SYSTEM DISCONNECT MEANS IF THEY ARE NOT LOCATED AT THE SAME LOCATION.
14. ALL MODULE GROUND CONNECTIONS SHALL BE MADE IN ACCORDANCE WITH NEC SECTION 690.4 (C)

ENGINEER:

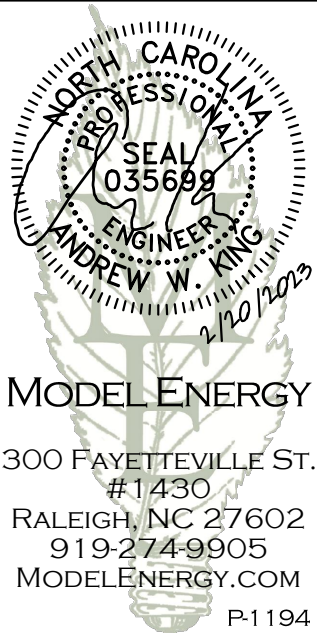

JOB TITLE:

NEW SOLAR PV SYSTEM

12.400 kW DC INPUT
10.000 kW AC EXPORT

Jimmy Barcia
234 Chedworth Dr,
Angier, NC 27501

© 2023 MODEL ENERGY, PLLC EXPRESSLY RESERVES ITS COMMON LAW COPYRIGHT AND OTHER PROPERTY RIGHTS IN THESE PLANS. THESE PLANS ARE NOT TO BE REPRODUCED, CHANGED OR COPIED IN ANY FORM OR MANNER WHATSOEVER, NOR ARE THEY TO BE ASSIGNED TO ANY THIRD PARTY WITHOUT FIRST OBTAINING THE EXPRESSED WRITTEN PERMISSION AND CONSENT OF MODEL ENERGY, PLLC.

CLIENT:

READY SOLAR

ISSUED FOR:	DATE:
CONSTRUCTION	2/23/2023

ELECTRICAL
INFORMATION

PV4.2





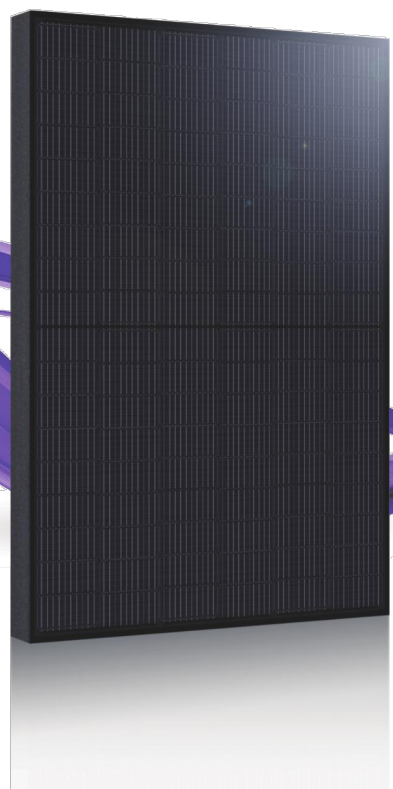

FBM_MFG-BB / 108 cells
390W - 405 W
Mono-Crystalline PV Module

URE Peach module uses URE state-of-the-art cell cutting technology, and advanced module manufacturing experiences.



Key Features

-  Positive power tolerance +0 ~ +5 watt
-  100% EL inline inspection Better module reliability
-  Withstand heavy loading front load 5400 Pa & rear load 2400 Pa
-  Design for 1000 VDC Reduce the system BOS effectively
-  Excellent low light performance 3.5% relative eff. Reduction at low (200W/m²)



For more information, please visit us at www.urecorp.com

Electrical Data

Model - STC		FBM390MFG-BB	FBM395MFG-BB	FBM400MFG-BB	FBM405MFG-BB
Maximum Rating Power (Pmax)	[W]	390	395	400	405
Module Efficiency	[%]	19.98	20.23	20.49	20.75
Open Circuit Voltage (Voc)	[V]	36.84	37.03	37.20	37.36
Maximum Power Voltage	[V]	30.82	31.00	31.17	31.36
Short Circuit Current	[A]	13.50	13.59	13.68	13.78
Maximum Power Current	[A]	12.66	12.75	12.84	12.92

*Standard Test Condition (STC): Cell Temperature 25 °C, Irradiance 1000 W/m², AM 1.5
*Values without tolerance are typical numbers.Measurement tolerance: ± 3%

Mechanical Data

Item	Specification
Dimensions	1723 mm (L) ¹ x 1133 mm (W) ¹ x 35 mm (D) ² / 67.83" (L) ¹ x 44.61" (W) ¹ x 1.38" (D) ²
Weight	21.7 kg / 47.84 lbs
Solar Cell	12x9 pieces monocrystalline solar cells series strings
Front Glass	White toughened safety glass, 3.2mm thickness
Cell Encapsulation	EVA (Ethylene-Vinyl-Acetate)
Frame	Black anodized aluminum profile
Junction Box	IP≥ 68, 3 diodes
Cable & Connector	Potrait : 500 mm (cable length can be customized), 1 x 4 mm ² compatible with MC4
Package Configuration	31 pcs Per Pallet, 806 pcs per 40' HQ container

¹ : With assembly tolerance of ± 2 mm [± 0.08"]
² : With assembly tolerance of ± 0.8 mm [± 0.03"]

Operating Conditions

Item	Specification
Mechanical Load	5400 Pa
Maximum System Voltage	1000V
Series Fuse Rating	30 A
Operating Temperature	-40 to 85 °C

Temperature Characteristics

Item	Specification
Nominal Module Operating Temperature	45°C ± 2°C
Temperature Coefficient of Isc	0.048 % / °C
Temperature Coefficient of Voc	-0.27 % / °C
Temperature Coefficient of Pmax	-0.32 % / °C

*Nominal module operating temperature (NMOT): Air mass AM 1.5, irradiance 800W/m², temperature 20°C, windspeed 1 m/s.
*Reduction in efficiency from 1000W/m² to 200W/m² at 25°C: 3.5 ± 2%.

Engineering Drawing (mm)

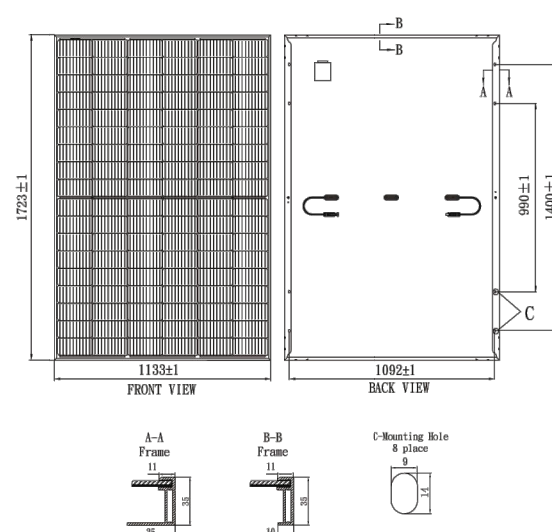

Dependence on Irradiance

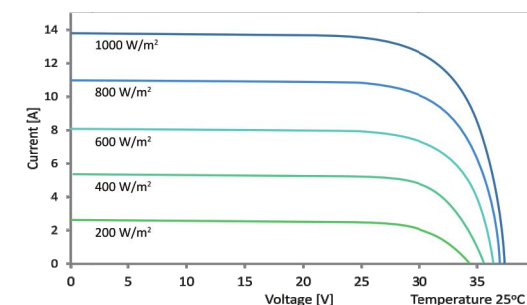

Reliability with Warranty

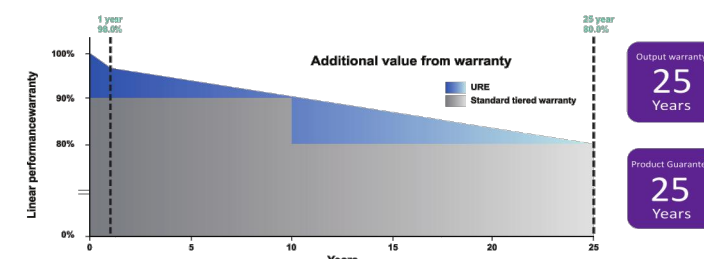

For more information, please visit us at www.urecorp.com

United Renewable Energy Co., Ltd.

Taipei Office
9F, NO. 295, Sec. 2, Tiding Blvd.,
Neihu Dist., Taipei 11493, Taiwan
Tel : +886-2-2656-2000
Fax : +886-2-2656-0593
e-mail : sales@urecorp.com

Headquarters
No. 7, Li-Hsin 3rd Road, Hsinchu Science Park
Hsinchu city 30078, Taiwan
Tel : +886-3-578-0011
Fax : +886-3-578-1255

ENGINEER:



MODEL ENERGY
300 FAYETTEVILLE ST.
#1430
RALEIGH, NC 27602
919-274-9905
MODELENERGY.COM
P-1194

JOB TITLE:

NEW SOLAR PV SYSTEM

12.400 kW DC INPUT
10.000 kW AC EXPORT

Jimmy Barcia
234 Chedworth Dr,
Angier, NC 27501

© 2023 MODEL ENERGY, PLLC EXPRESSLY RESERVES ITS COMMON LAW COPYRIGHT AND OTHER PROPERTY RIGHTS IN THESE PLANS. THESE PLANS ARE NOT TO BE REPRODUCED, CHANGED OR COPIED IN ANY FORM OR MANNER WHATSOEVER, NOR ARE THEY TO BE ASSIGNED TO ANY THIRD PARTY WITHOUT FIRST OBTAINING THE EXPRESSED WRITTEN PERMISSION AND CONSENT OF MODEL ENERGY, PLLC.

CLIENT:

READY SOLAR

ISSUED FOR: CONSTRUCTION
DATE: 2/23/2023

LABELS,
DETAILS & SPECS

PV5.1

Power Optimizer For Residential Installations

S440, S500



POWER OPTIMIZER

Enabling PV power optimization at the module level

- Specifically designed to work with SolarEdge residential inverters
- Mitigates all types of module mismatch loss, from manufacturing tolerance to partial shading
- Detects abnormal PV connector behavior, preventing potential safety issues*
- Faster installations with simplified cable management and easy assembly using a single bolt
- Module-level voltage shutdown for installer and firefighter safety
- Flexible system design for maximum space utilization
- Superior efficiency (99.5%)
- Compatible with bifacial PV modules

* Functionality subject to inverter model and firmware version

solaredge.com



Power Optimizer For Residential Installations S440, S500

	S440	S500	UNIT
Rated Input DC Power ⁽¹⁾	440	500	W
Absolute Maximum Input Voltage (Voc)		60	Vdc
MPPT Operating Range		8 - 60	Vdc
Maximum Short Circuit Current (Isc) of Connected PV Module	14.5	15	Adc
Maximum Efficiency		99.5	%
Weighted Efficiency		98.6	%
Overtoltage Category		II	
OUTPUT DURING OPERATION			
Maximum Output Current		15	Adc
Maximum Output Voltage		60	Vdc
OUTPUT DURING STANDBY (POWER OPTIMIZER DISCONNECTED FROM INVERTER OR INVERTER OFF)			
Safety Output Voltage per Power Optimizer		1	Vdc
STANDARD COMPLIANCE			
EMC	FCC Part 15 Class B, IEC61000-6-2, IEC61000-6-3, CISPR11, EN-55011		
Safety	IEC62109-1 (class II safety), UL1741		
Material	UL94 V-0, UV Resistant		
RoHS	Yes		
Fire Safety	VDE-AR-E 2100-712:2013-05		
INSTALLATION SPECIFICATIONS			
Maximum Allowed System Voltage		1000	Vdc
Dimensions (W x L x H)		129 x 155 x 30	mm
Weight (including cables)		655 / 1.5	gr / lb
Input Connector		MC4 ⁽²⁾	
Input Wire Length		0.1	m
Output Connector		MC4	
Output Wire Length		(+) 2.3, (-) 0.10	m
Operating Temperature Range ⁽³⁾		-40 to +85	°C
Protection Rating		IP68 / NEMA6P	
Relative Humidity		0 - 100	%

(1) Rated power of the module at STC will not exceed the Power Optimizer Rated Input DC Power. Modules with up to +5% power tolerance are allowed
 (2) For other connector types please contact SolarEdge
 (3) For ambient temperature above +70°C / +158°F power de-rating is applied. Refer to Power Optimizers Temperature De-Rating Technical Note for more details

PV System Design Using a SolarEdge Inverter		Single Phase HD-Wave	Three Phase	Three Phase for 277/480V Grid	
Minimum String Length (Power Optimizers)	S440, S500	8	16	18	
Maximum String Length (Power Optimizers)		25	50	50	
Maximum Nominal Power per String ⁽⁴⁾		5700	11250 ⁽⁵⁾	12750 ⁽⁶⁾	W
Parallel Strings of Different Lengths or Orientations			Yes		

(4) If the inverters rated AC power ≤ maximum nominal power per string, then the maximum power per string will be able to reach up to the inverters maximum input DC power Refer to: <https://www.solaredge.com/sites/default/files/se-power-optimizer-single-string-design-application-note.pdf>
 (5) For the 230/400V grid: It is allowed to install up to 13,500W per string when the maximum power difference between each string is 2,000W
 (6) For the 277/480V grid: It is allowed to install up to 15,000W per string when the maximum power difference between each string is 2,000W
 (7) It is not allowed to mix S-series and P-series Power Optimizers in new installations

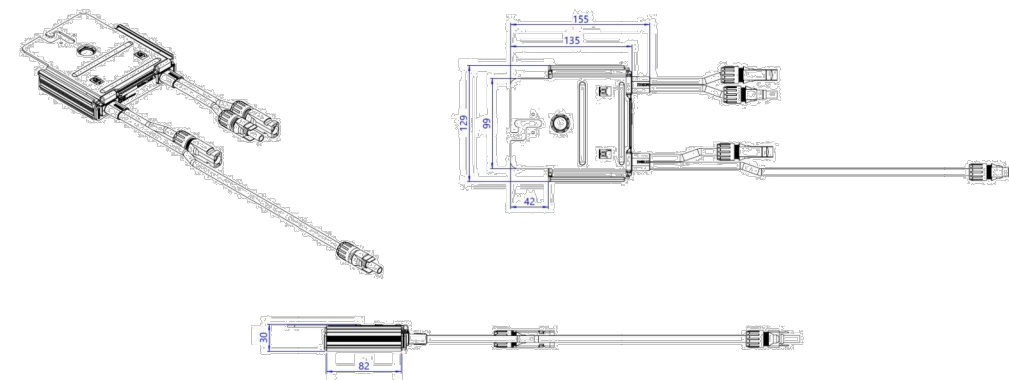

© SolarEdge Technologies, Inc. All rights reserved. SOLAREEDGE, the SolarEdge logo, OPTIMIZED BY SOLAREEDGE are trademarks or registered trademarks of SolarEdge Technologies, Inc. All other trademarks mentioned herein are trademarks of their respective owners. Date: 12/2021 DS-000091-1.2-ENG. Subject to change without notice.

CE RoHS

ENGINEER:



MODEL ENERGY
 300 FAYETTEVILLE ST.
 #1430
 RALEIGH, NC 27602
 919-274-9905
 MODELENERGY.COM
 P-1194

JOB TITLE:

NEW SOLAR PV SYSTEM

12.400 kW DC INPUT
 10.000 kW AC EXPORT

Jimmy Barcia
 234 Chedworth Dr,
 Angier, NC 27501

© 2023 MODEL ENERGY, PLLC EXPRESSLY RESERVES ITS COMMON LAW COPYRIGHT AND OTHER PROPERTY RIGHTS IN THESE PLANS. THESE PLANS ARE NOT TO BE REPRODUCED, CHANGED OR COPIED IN ANY FORM OR MANNER WHATSOEVER, NOR ARE THEY TO BE ASSIGNED TO ANY THIRD PARTY WITHOUT FIRST OBTAINING THE EXPRESSED WRITTEN PERMISSION AND CONSENT OF MODEL ENERGY, PLLC.

CLIENT:

READY SOLAR

ISSUED FOR: DATE:
 CONSTRUCTION 2/23/2023

EQUIPMENT
 SPEC SHEETS

PV5.2

Single Phase Inverter with HD-Wave Technology

for North America

SE3000H-US / SE3800H-US / SE5000H-US / SE6000H-US / SE7600H-US / SE10000H-US / SE11400H-US



12-25
YEAR WARRANTY

INVERTERS

Optimized installation with HD-Wave technology

- Specifically designed to work with power optimizers
- Record-breaking efficiency
- Fixed voltage inverter for longer strings
- Integrated arc fault protection and rapid shutdown for NEC 2014 and 2017, per article 690.11 and 690.12
- UL1741 SA certified, for CPUC Rule 21 grid compliance
- Extremely small
- Built-in module-level monitoring
- Outdoor and indoor installation
- Optional: Revenue grade data, ANSI C12.20 Class 0.5 (0.5% accuracy)

solaredge.com



Single Phase Inverter with HD-Wave Technology for North America

SE3000H-US / SE3800H-US / SE5000H-US / SE6000H-US / SE7600H-US / SE10000H-US / SE11400H-US

	SE3000H-US	SE3800H-US	SE5000H-US	SE6000H-US	SE7600H-US	SE10000H-US	SE11400H-US		
OUTPUT									
Rated AC Power Output	3000	3800 @ 240V 3300 @ 208V	5000	6000 @ 240V 5000 @ 208V	7600	10000	11400 @ 240V 10000 @ 208V	VA	
Maximum AC Power Output	3000	3800 @ 240V 3300 @ 208V	5000	6000 @ 240V 5000 @ 208V	7600	10000	11400 @ 240V 10000 @ 208V	VA	
AC Output Voltage Min.-Nom.-Max. (211 - 240 - 264)	✓	✓	✓	✓	✓	✓	✓	Vac	
AC Output Voltage Min.-Nom.-Max. (183 - 208 - 229)	-	✓	-	✓	-	-	✓	Vac	
AC Frequency (Nominal)	59.3 - 60 - 60.5 ⁽¹⁾							Hz	
Maximum Continuous Output Current @240V	12.5	16	21	25	32	42	47.5	A	
Maximum Continuous Output Current @208V	-	16	-	24	-	-	48.5	A	
GFDI Threshold	1							A	
Utility Monitoring, Islanding Protection, Country Configurable Thresholds	Yes								
INPUT									
Maximum DC Power @240V	4650	5900	7750	9300	11800	15500	17650	W	
Maximum DC Power @208V	-	5100	-	7750	-	-	15500	W	
Transformer-less, Ungrounded	Yes								
Maximum Input Voltage	480							Vdc	
Nominal DC Input Voltage	380				400			Vdc	
Maximum Input Current @240V ⁽²⁾	8.5	10.5	13.5	16.5	20	27	30.5	Adc	
Maximum Input Current @208V ⁽²⁾	-	9	-	13.5	-	-	27	Adc	
Max. Input Short Circuit Current	45							Adc	
Reverse-Polarity Protection	Yes								
Ground-Fault Isolation Detection	600k Ω Sensitivity								
Maximum Inverter Efficiency	99	99.2				99 @ 240V 98.5 @ 208V		%	
CEC Weighted Efficiency	99						99 @ 240V 98.5 @ 208V	%	
Nighttime Power Consumption	< 2.5							W	
ADDITIONAL FEATURES									
Supported Communication Interfaces	RS485, Ethernet, ZigBee (optional), Cellular (optional)								
Revenue Grade Data, ANSI C12.20	Optional ⁽³⁾								
Rapid Shutdown - NEC 2014 and 2017 690.12	Automatic Rapid Shutdown upon AC Grid Disconnect								
STANDARD COMPLIANCE									
Safety	UL1741, UL1741 SA, UL1599B, CSA C22.2, Canadian AFCI according to T.I.L. M-07								
Grid Connection Standards	IEEE1547, Rule 21, Rule 14 (H1)								
Emissions	FCC Part 15 Class B								
INSTALLATION SPECIFICATIONS									
AC Output Conduit Size / AWG Range	1" Maximum / 14-6 AWG				1" Maximum / 14-4 AWG				
DC Input Conduit Size / # of Strings / AWG Range	1" Maximum / 1-2 strings / 14-6 AWG				1" Maximum / 1-3 strings / 14-6 AWG				
Dimensions with Safety Switch (HxWxD)	17.7 x 14.6 x 6.8 / 450 x 370 x 174				21.3 x 14.6 x 7.3 / 540 x 370 x 185				in / mm
Weight with Safety Switch	22 / 10	25.1 / 11.4	26.2 / 11.9	38.8 / 17.6			lb / kg		
Noise	< 25				<50				dBA
Cooling	Natural Convection								
Operating Temperature Range	-13 to +140 / -25 to +60 ⁽⁴⁾ (-40°F / -40°C option) ⁽⁵⁾							°F / °C	
Protection Rating	NEMA 4X (Inverter with Safety Switch)								

⁽¹⁾ For other regional settings please contact SolarEdge support
⁽²⁾ A higher current source may be used; the inverter will limit its input current to the values stated
⁽³⁾ Revenue grade inverter P/N: SExxxxH-US000NNC2
⁽⁴⁾ For power de-rating information refer to: <https://www.solaredge.com/sites/default/files/se-temperature-derating-note-na.pdf>
⁽⁵⁾ -40 version P/N: SExxxxH-US000NNU4

ENGINEER:



MODEL ENERGY

300 FAYETTEVILLE ST.
#1430
RALEIGH, NC 27602
919-274-9905
MODELENERGY.COM
P-1194

JOB TITLE:

NEW SOLAR PV SYSTEM

12.400 kW DC INPUT
10.000 kW AC EXPORT

Jimmy Barcia
234 Chedworth Dr,
Angier, NC 27501

© 2023 MODEL ENERGY, PLLC EXPRESSLY RESERVES ITS COMMON LAW COPYRIGHT AND OTHER PROPERTY RIGHTS IN THESE PLANS. THESE PLANS ARE NOT TO BE REPRODUCED, CHANGED OR COPIED IN ANY FORM OR MANNER WHATSOEVER, NOR ARE THEY TO BE ASSIGNED TO ANY THIRD PARTY WITHOUT FIRST OBTAINING THE EXPRESSED WRITTEN PERMISSION AND CONSENT OF MODEL ENERGY, PLLC.

CLIENT:

READY SOLAR

ISSUED FOR: DATE:
CONSTRUCTION 2/23/2023

EQUIPMENT
SPEC SHEETS

PV5.3

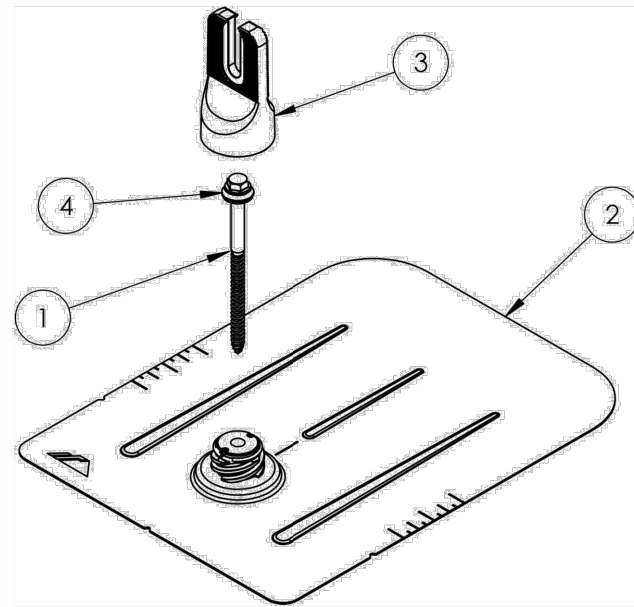

ITEM NO.	DESCRIPTION
1	BOLT LAG 5/16 X 4.75"
2	ASSY, FLASHING
3	ASSY, CAP
4	WASHER, EPDM BACKED

FLASHFOOT 2

Part Number	Description
FF2-01-M1	FLASHFOOT2, MILL
FF2-01-B1	FLASHFOOT2, BLACK

1) Bolt, Lag 5/16" x 4.75"

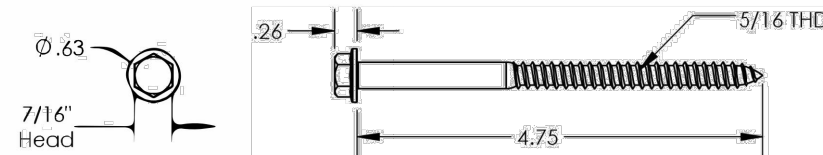

Property	Value
Material	300 Series Stainless Steel
Finish	Clear

v1.20

2) Assy, Flashing

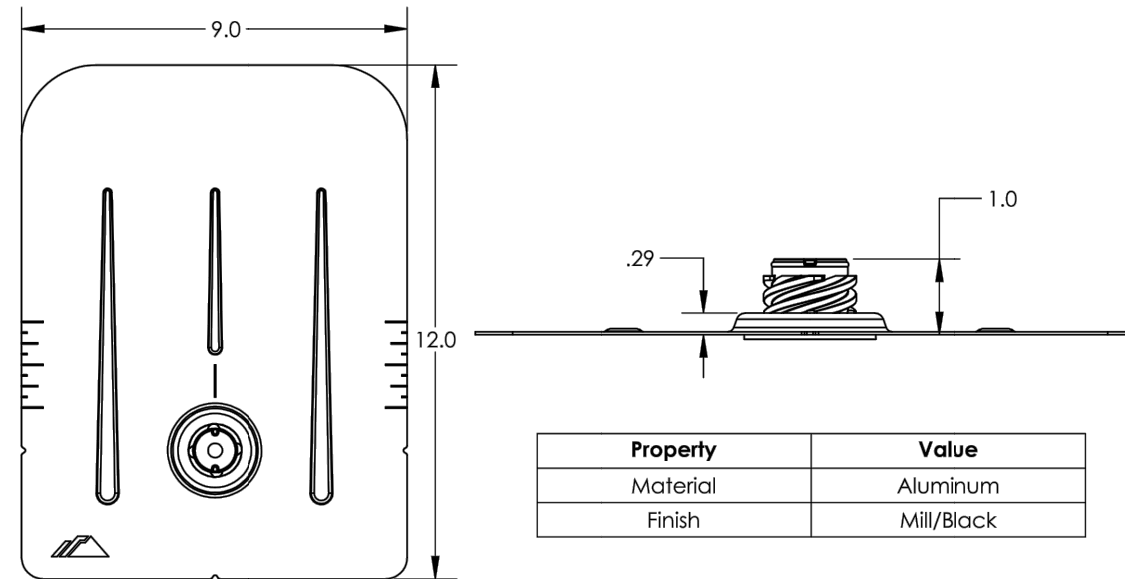

Property	Value
Material	Aluminum
Finish	Mill/Black

3) Assy, Cap

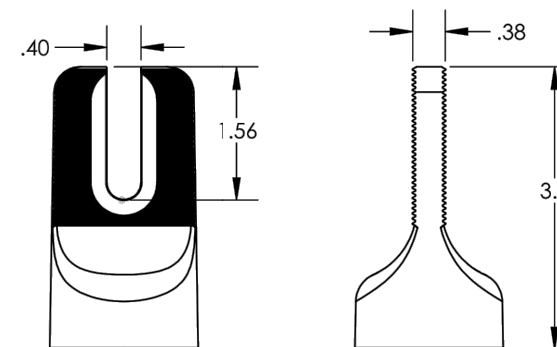

Property	Value
Material	Aluminum
Finish	Mill/Black

4) Washer, EPDM Backed

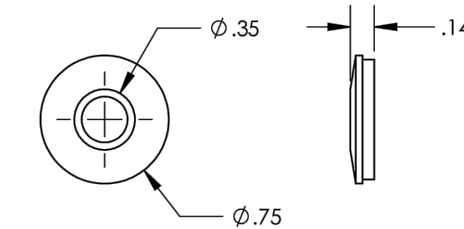

Property	Value
Material	300 Series Stainless Steel
Finish	Clear

v1.20

ENGINEER:



MODEL ENERGY

300 FAYETTEVILLE ST.
#1430
RALEIGH, NC 27602
919-274-9905
MODELENERGY.COM
P-1194

JOB TITLE:

NEW SOLAR PV SYSTEM

12.400 kW DC INPUT
10.000 kW AC EXPORT

Jimmy Barcia
234 Chedworth Dr,
Angier, NC 27501

© 2023 MODEL ENERGY, PLLC EXPRESSLY RESERVES ITS COMMON LAW COPYRIGHT AND OTHER PROPERTY RIGHTS IN THESE PLANS. THESE PLANS ARE NOT TO BE REPRODUCED, CHANGED OR COPIED IN ANY FORM OR MANNER WHATSOEVER, NOR ARE THEY TO BE ASSIGNED TO ANY THIRD PARTY WITHOUT FIRST OBTAINING THE EXPRESSED WRITTEN PERMISSION AND CONSENT OF MODEL ENERGY, PLLC.

CLIENT:

READY SOLAR

ISSUED FOR: CONSTRUCTION
DATE: 2/23/2023

EQUIPMENT
SPEC SHEETS

PV5.4



XR10 Rail

Cut Sheet

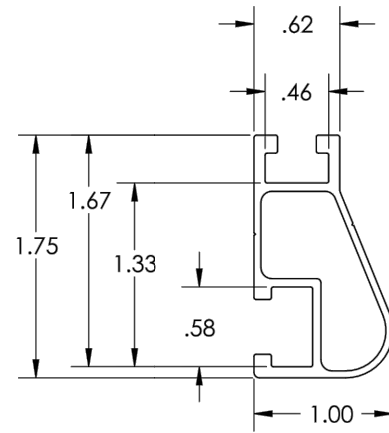
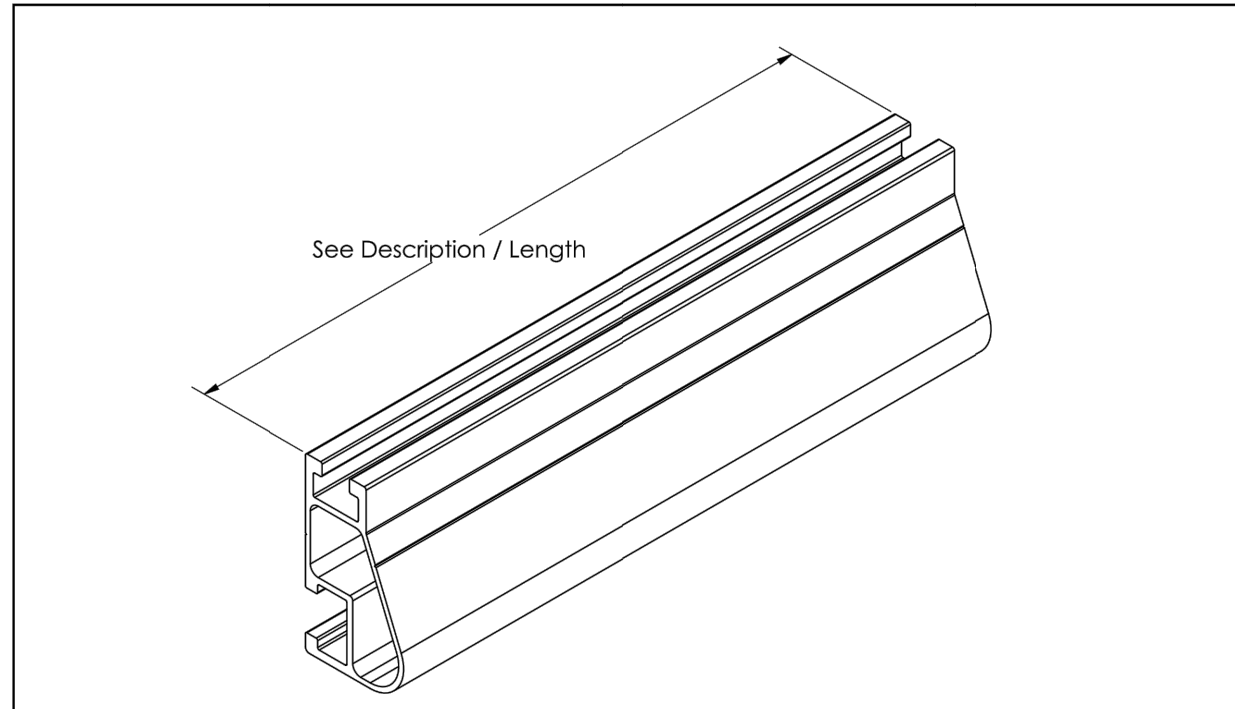

Rail Section Properties	
Property	Value
Total Cross-Sectional Area	0.363 in ²
Section Modulus (X-axis)	0.136 in ³
Moment of Inertia (X-axis)	0.124 in ⁴
Moment of Inertia (Y-axis)	0.032 in ⁴
Torsional Constant	0.076 in ³
Polar Moment of Inertia	0.033 in ⁴

Clear Part Number	Black Part Number	Description / Length	Material	Weight
XR-10-132A	XR-10-132B	XR10, Rail 132" (11 Feet)	6000-Series Aluminum	4.67 lbs.
XR-10-168A	XR-10-168B	XR10, Rail 168" (14 Feet)		5.95 lbs.
XR-10-204A	XR-10-204B	XR10, Rail 204" (17 Feet)		7.22 lbs.

v1.0



XR10 Bonded Splice

Cut Sheet

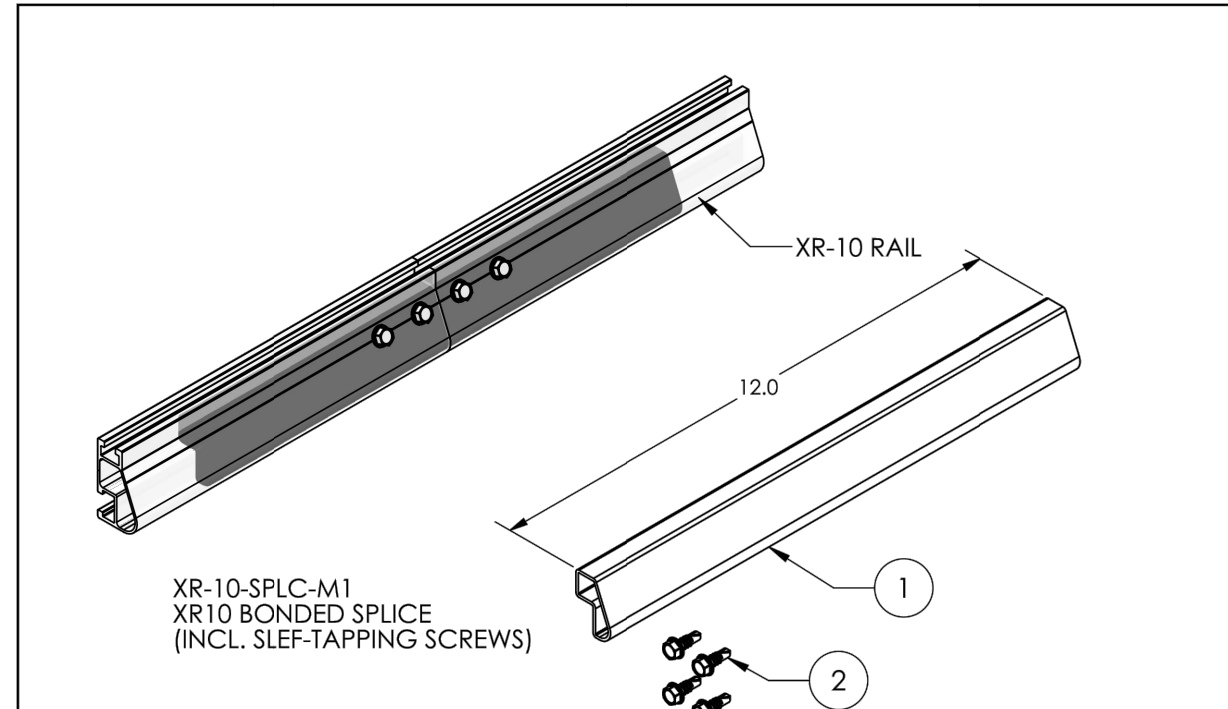

XR-10-SPLC-M1
XR10 BONDED SPLICE
(INCL. SELF-TAPPING SCREWS)

1) Splice, XR10, Mill 12" long

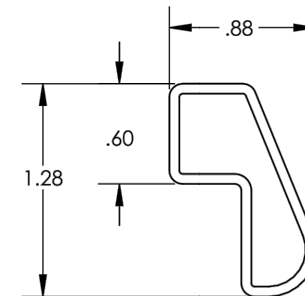

Property	Value
Material	6000 Series Aluminum
Finish	Mill

2) Screw, Self Drilling

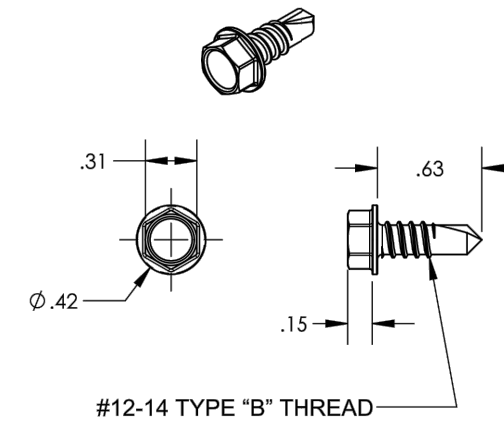

Property	Value
Material	300 Series Stainless Steel
Finish	Clear

v1.10

ENGINEER:



MODEL ENERGY

300 FAYETTEVILLE ST.
#1430
RALEIGH, NC 27602
919-274-9905
MODELENERGY.COM
P-1194

JOB TITLE:

NEW SOLAR PV SYSTEM

12.400 kW DC INPUT
10.000 kW AC EXPORT

Jimmy Barcia
234 Chedworth Dr,
Angier, NC 27501

© 2023 MODEL ENERGY, PLLC EXPRESSLY RESERVES ITS COMMON LAW COPYRIGHT AND OTHER PROPERTY RIGHTS IN THESE PLANS. THESE PLANS ARE NOT TO BE REPRODUCED, CHANGED OR COPIED IN ANY FORM OR MANNER WHATSOEVER, NOR ARE THEY TO BE ASSIGNED TO ANY THIRD PARTY WITHOUT FIRST OBTAINING THE EXPRESSED WRITTEN PERMISSION AND CONSENT OF MODEL ENERGY, PLLC.

CLIENT:

READY SOLAR

ISSUED FOR: DATE:
CONSTRUCTION 2/23/2023

EQUIPMENT
SPEC SHEETS

PV5.5

READY SOLAR

Customer: Jimmy Barcia
Installer: Ready Solar
Subject: PV System Structural Compliance
Date: 2/23/2023

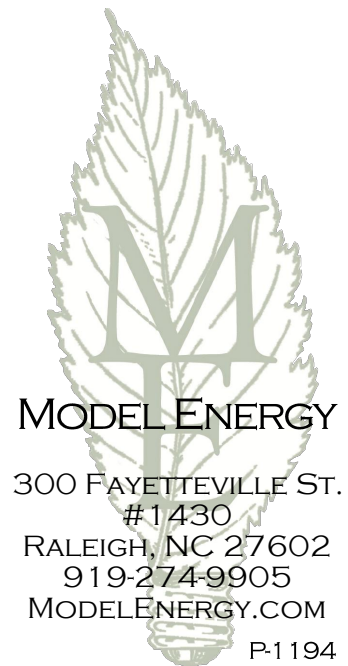

To whom it may concern:

Model Energy, PLLC has reviewed the installation details of the proposed PV system that is to be installed by Ready Solar at 234 Chedworth Dr, Angier, NC 27501. The conditions of the existing structure have been reviewed and validated by Model Energy, PLLC. The existing roof structure has been designed to support the additional loads of the proposed PV system. In addition, the racking and fastening system shall be capable of securing the system to the structure under design conditions when installed properly and in accordance with the racking and fastening arrangement detailed within the accompanying permit set. The installation design is compliant with current 2018 North Carolina state and national building codes.

Thank you,

Andrew King, PE

