

VICINITY MAP

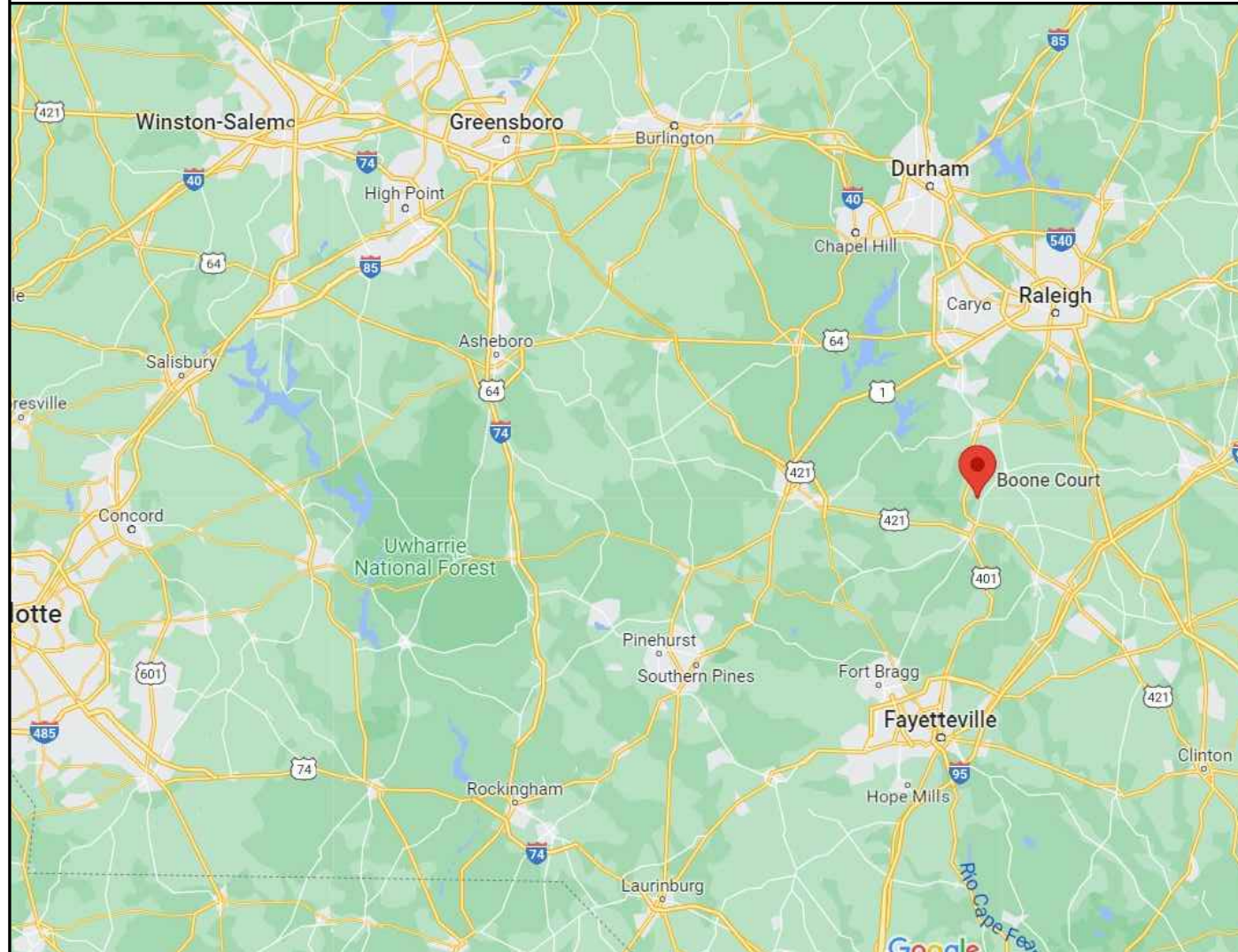

PROPERTY MAP



MODEL ENERGY
 300 FAYETTEVILLE ST.
 #1430
 RALEIGH, NC 27602
 919-274-9905
 MODELENERGY.COM
 P-1194

JOB TITLE:

NEW SOLAR PV SYSTEM
 8.800 kW DC INPUT
 7.600 kW AC EXPORT

Brian Taptick
 39 Boone Ct,
 Angier, NC 27501

CLIENT:

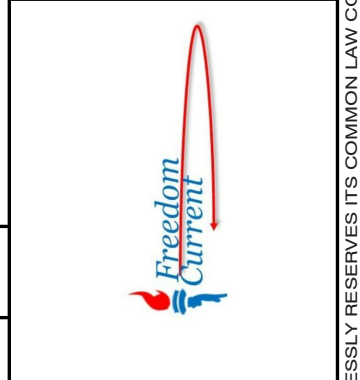

ISSUED FOR:	DATE:
CONSTRUCTION	11-11/23/22

PROJECT INFORMATION

PV1.1

SCOPE OF WORK

SITE CONDITION

SHEET INDEX

(22) URECO FBM400MFG-BB
 (1) SOLAR EDGE SE7600H-US
 (22) SOLAR EDGE S440
 ROOF MOUNT: IRONRIDGE FLASHFOOT 2
 MOUNTING RAILS: IRONRIDGE XR10

ASCE 7-10 WIND SPEED - 117 MPH
 EXPOSURE CATEGORY - B
 RISK CATEGORY - II

PV1.1	PROJECT INFORMATION
PV2.1	SITE INFORMATION
PV3.1 - 3.2	STRUCTURAL INFORMATION
PV4.1	ELECTRICAL INFORMATION
PV5.1 - 5.5	LABELS, DETAILS & SPECS

INTERCONNECTIONS TYPE

CODE REFERENCES

UTILITY COMPANY

BACKFED BREAKER

2017 NATIONAL ELECTRIC CODE
 2018 NORTH CAROLINA RESIDENTIAL CODE
 2018 NORTH CAROLINA BUILDING CODE
 2018 NORTH CAROLINA FIRE CODE

DUKE ENERGY PROGRESS

LEGEND

- DISCONNECT SWITCH
- FUSE
- CIRCUIT BREAKER
- EQUIP. GROUND

NOTICE TO CONTRACTOR
 All construction must comply with current NC Building Codes and is subject to field inspection and verification.

APPROVED
Unlimited building only review
 Permit holder responsible for full compliance with the code

02/13/2023

© 2022 MODEL ENERGY, PLLC EXPRESSLY RESERVES ITS COMMON LAW COPYRIGHT AND OTHER PROPERTY RIGHTS IN THESE PLANS. THESE PLANS ARE NOT TO BE REPRODUCED, CHANGED OR COPIED IN ANY FORM OR MANNER WHATSOEVER, NOR ARE THEY TO BE ASSIGNED TO ANY THIRD PARTY WITHOUT FIRST OBTAINING THE EXPRESSED WRITTEN PERMISSION AND CONSENT OF MODEL ENERGY, PLLC.

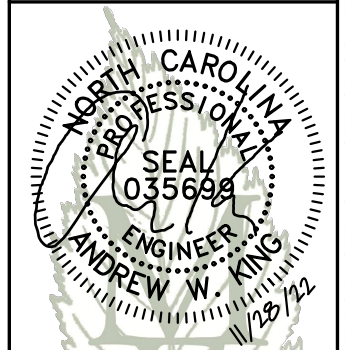
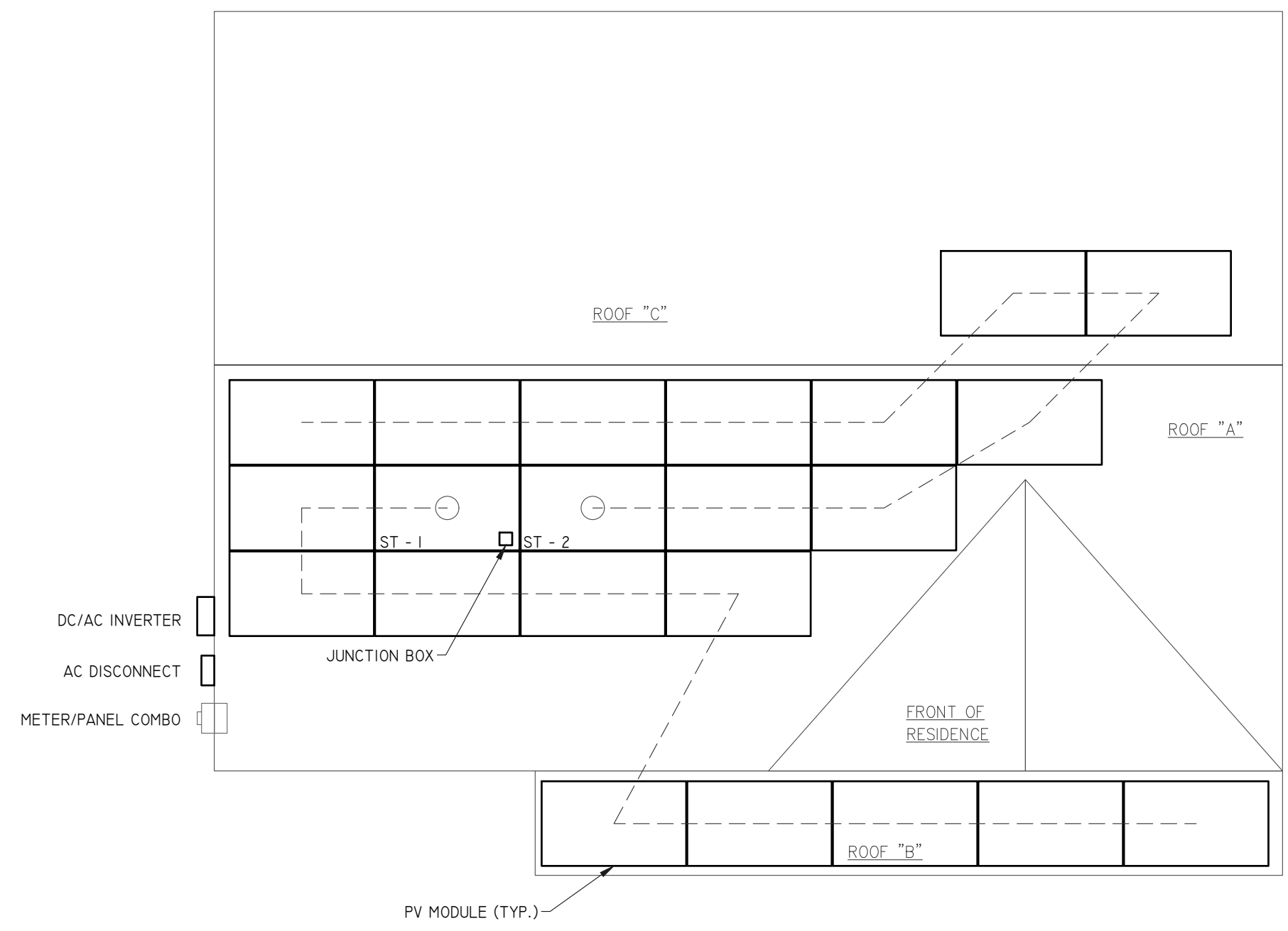
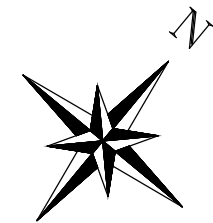

MODEL ENERGY
 300 FAYETTEVILLE ST.
 #1430
 RALEIGH, NC 27602
 919-274-9905
 MODELENERGY.COM
 P-1194

JOB TITLE:

NEW SOLAR PV SYSTEM
 8.800 kW DC INPUT
 7.600 kW AC EXPORT

Brian Taptick
 39 Boone Ct,
 Angier, NC 27501

CLIENT:

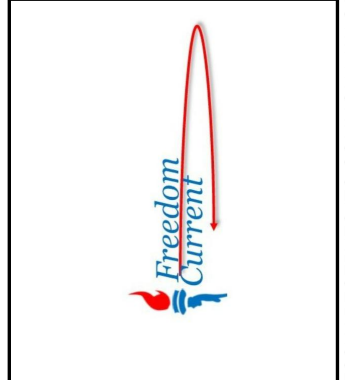

ISSUED FOR:	DATE:
CONSTRUCTION	v1-11/23/22

SITE INFORMATION

PV2.1

NOTE: PROVIDE ADDITIONAL JUNCTION BOXED AS REQUIRED TO COMBINE MODULES ON DIFFERENT ARRAYS INTO A SINGLE STRING

1 SITE PLAN
 SCALE: 3/16" = 1' - 0"

© 2022 MODEL ENERGY, PLLC EXPRESSLY RESERVES ITS COMMON LAW COPYRIGHT AND OTHER PROPERTY RIGHTS IN THESE PLANS. THESE PLANS ARE NOT TO BE REPRODUCED, CHANGED OR COPIED IN ANY FORM OR MANNER WHATSOEVER, NOR ARE THEY TO BE ASSIGNED TO ANY THIRD PARTY WITHOUT FIRST OBTAINING THE EXPRESSED WRITTEN PERMISSION AND CONSENT OF MODEL ENERGY, PLLC.

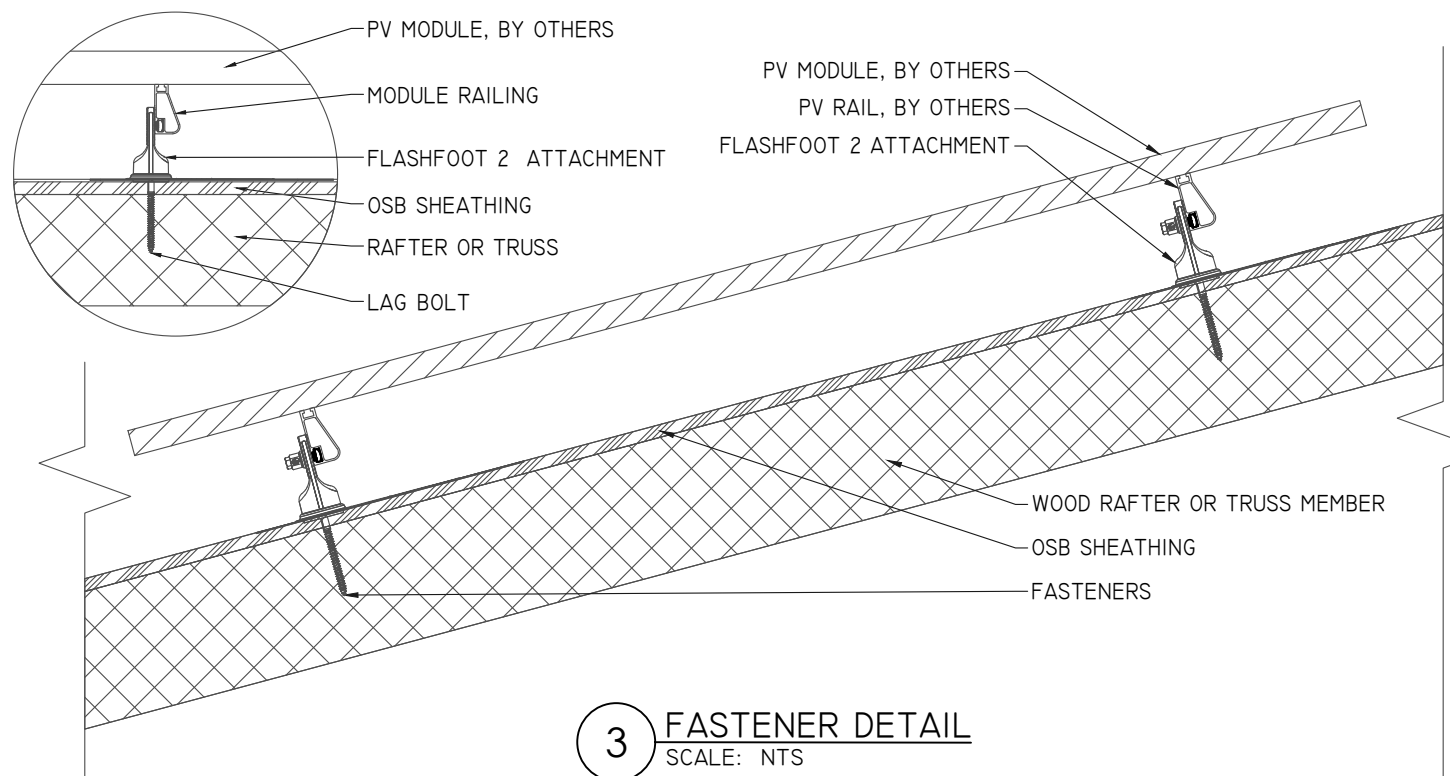

3 FASTENER DETAIL
SCALE: NTS

ARRAY "B" SUMMARY	
# MODULES	5
# ROOF MOUNTS	16
RAIL LENGTH	65 FT.
ARRAY AREA	105 SQFT.
ARRAY WEIGHT	320 LBS.
AZIMUTH @ SN	135°
TILT ANGLE	31°

ARRAY "A" SUMMARY	
# MODULES	15
# ROOF MOUNTS	38
RAIL LENGTH	178 FT.
ARRAY AREA	315 SQFT.
ARRAY WEIGHT	940 LBS.
AZIMUTH @ SN	135°
TILT ANGLE	27°

MOUNTING RAILS	
MAKE	IRONRIDGE
MODEL	XRIO
MATERIAL	ALUMINUM
WEIGHT	1.25 LBS/SQFT
SPACING	34"

STATEMENT OF STRUCTURAL COMPLIANCE

THE EXISTING ROOF STRUCTURE HAS BEEN DESIGNED TO SUPPORT THE ADDITIONAL LOADS OF THE PURPOSED PV SYSTEM. IN ADDITION, THE RACKING AND FASTENING SYSTEM SHALL BE CAPABLE OF SECURING THE SYSTEM TO THE STRUCTURE UNDER DESIGN CONDITIONS WHEN INSTALLED PROPERLY AND IN ACCORDANCE WITH THE RACKING AND FASTENING ARRANGEMENT DETAILED WITHIN THESE DRAWINGS.

SIGNED: 
 NAME: ANDREW W. KING, PE
 TITLE: PROFESSIONAL ENGINEER

ROOF LOADING	
GROUND SNOW LOAD:	15 LBS./SQFT.
LIVE LOAD:	20 LBS./SQFT.
DEAD LOAD:	
ROOFING	3.9 LBS./SQFT.
PV ARRAY	3.0 LBS./SQFT.
TOTAL	6.9 LBS./SQFT.
WIND LOAD:	
UPLIFT ZONE 1	-24.6 LBS/SQFT
UPLIFT ZONE 2	-29.0 LBS/SQFT
UPLIFT ZONE 3	-29.0 LBS/SQFT
DOWNWARD	23.0 LBS/SQFT
FASTENER LOAD:	
UPLIFT ZONE 1	-274 LBS
UPLIFT ZONE 2	-216 LBS
UPLIFT ZONE 3	-108 LBS
DOWNWARD	257 LBS

ROOF MOUNT & FASTENER	
ROOF MOUNT:	
MAKE	IRONRIDGE
MODEL	FLASHFOOT2
MATERIAL	ALUMINUM
FASTENER	
MAKE	GENERIC
MODEL	LAG BOLT
MATERIAL	304 SS
SIZE	5/16" X 4"
GENERAL	
WEIGHT	1 LBS
FASTENERS PER MOUNT	1 PER MOUNT
MAX. PULL-OUT FORCE	800 LBS.
SAFETY FACTOR	2
DESIGN PULL-OUT FORCE	400 LBS.

- LAG BOLT EMBEDDED WITH 2.5" OF THREAD IN WOOD RAFTER OR TRUSSES MEMBER

ROOF SUMMARY	
STRUCTURE:	
TYPE	TRUSS
MATERIAL	SOUTHERN PINE #2
SIZE	2" X 4"
SPACING	24"
EFF. SPAN	
ROOF "A"	15'-11"
ROOF "B"	4'-1"
PITCH	
ROOF "A"	6/12
ROOF "B"	7/12
DENSITY	30 LBS./CU.FT.
DECKING:	
TYPE	OSB
MATERIAL	WOOD COMPOSITE
THICKNESS	7/16
WEIGHT	1.6 LBS./SQFT.
ROOFING:	
TYPE	ARCH SHINGLE
MATERIAL	ASPHALT
WEIGHT	2.3 LBS./SQFT.

PV MODULES	
MAKE	URECO
MODEL	FBM400MFG-BB
WIDTH	44.6"
LENGTH	67.8"
THICKNESS	1.4"
WEIGHT	48 LBS

ROOF ZONES:	
ALL ZONES	MAX. RAIL OVERHANG = 16"
☐ ZONE 1	MAX. FASTENER SPAN ZONE 1 = 72"
▨ ZONE 2	MAX. FASTENER SPAN ZONE 2 = 48"
▩ ZONE 3	MAX. FASTENER SPAN ZONE 3 = 24"

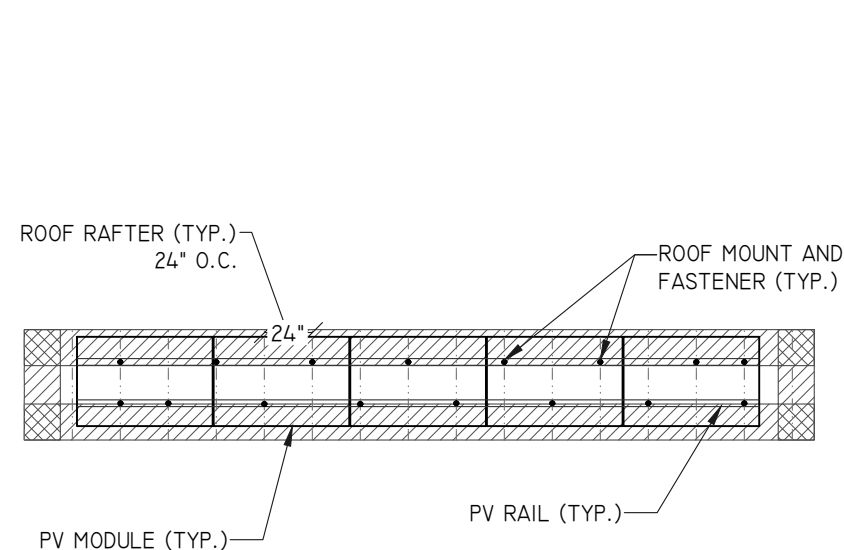

2 ROOF "B" PLANAR VIEW
SCALE: 1/8" = 1' -0"

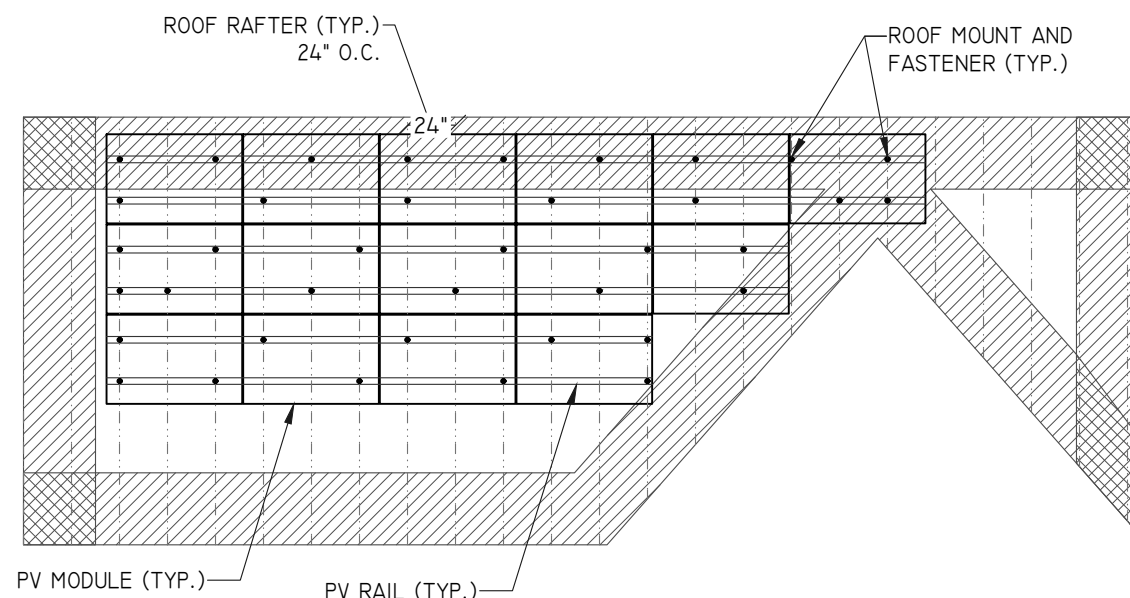

1 ROOF "A" PLANAR VIEW
SCALE: 1/8" = 1' -0"

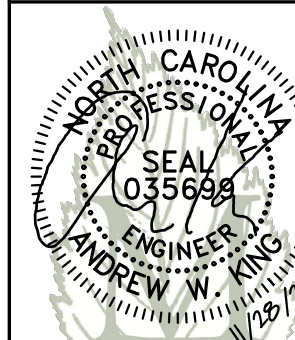

MODEL ENERGY

300 FAYETTEVILLE ST.
#1430
RALEIGH, NC 27602
919-274-9905
MODELENERGY.COM
P-1194

JOB TITLE:

NEW SOLAR PV SYSTEM
8.800 kW DC INPUT
7.600 kW AC EXPORT
Brian Taptick
39 Boone Ct,
Angier, NC 27501

CLIENT:

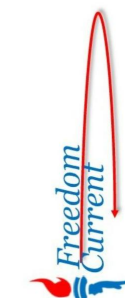

ISSUED FOR: DATE:
CONSTRUCTION v1-11/23/22

STRUCTURAL INFORMATION

PV3.1

© 2022 MODEL ENERGY, PLLC EXPRESSLY RESERVES ITS COMMON LAW COPYRIGHT AND OTHER PROPERTY RIGHTS IN THESE PLANS. THESE PLANS ARE NOT TO BE REPRODUCED, CHANGED OR COPIED IN ANY FORM OR MANNER WHATSOEVER, NOR ARE THEY TO BE ASSIGNED TO ANY THIRD PARTY WITHOUT FIRST OBTAINING THE EXPRESSED WRITTEN PERMISSION AND CONSENT OF MODEL ENERGY, PLLC.

PV MODULES	
MAKE	URECO
MODEL	FBM400MFG-BB
TECHNOLOGY	MONO-CRYST.
NOM. POWER (Pnom)	400 WATTS
NOM. VOLT. (Vmp)	31.17 VOLTS
O.C. VOLT. (Voc)	37.20 VOLTS
MAX. SYS. VOLT.	1000 V (UL)
TEMP. COEF. (Vtc)	-0.27 %/°C
NOM. CURR. (Imp)	12.84 AMPS
S.C. CURR. (Isc)	13.68 AMPS
MAX. SERIES FUSE	30 AMPS

MODULE OPTIMIZER	
MAKE	SOLAREEDGE
MODEL	S440
DC INPUT:	
RATED POWER	440 WATTS
VOLT. RANGE	8 - 60
MAX. SCC	14.5 AMPS
MAX. DC INPUT CURRENT	14.5 AMPS
DC OUTPUT:	
MAX. CURRENT	15 AMPS
MAX. VOLT.	60 VOLTS
MAX. SYSTEM VOLT.	1000 VOLTS
MIN. STRING	8 OPTIMIZERS
MAX. STRING	25 OPTIMIZERS
MAX. POWER	
INVERTERS: SE3000H-SE6000H	5700 WATTS
INVERTERS: SE7600H-SE11400H	5700 WATTS

JUNCTION BOX	
MAKE	SOLADECK
MODEL	0783-3R
PRO. RATING	NEMA 3R
VOLT. RATING	600 VOLTS
AMP RATING	120 AMPS
UL LISTING	UL 50

NOTES:

- PROVIDE ADDITIONAL JUNCTION BOXED AS REQUIRED TO COMBINE MODULES ON DIFFERENT ARRAYS INTO A SINGLE STRING

CONDUCTOR SCHEDULE													
TAG	CURRENT CARRYING CONDUCTORS				GROUNDING CONDUCTORS				CONDUIT/RACEWAY			NOTES	
	QTY.	SIZE	MATERIAL	INSULATION	QTY.	SIZE	MATERIAL	INSULATION	QTY.	SIZE	MATERIAL		LOCATION
C1	2	10 AWG	COPPER	PV WIRE	1	6 AWG	COPPER	BARE WIRE	-	-	-	FREE AIR	1
C2	4	10 AWG	COPPER	THWN-2	1	10 AWG	COPPER	THWN-2	1	1/2"	FMC/EMT/MC	EXT/INT	2,4
C3	3	8 AWG	COPPER	THWN	1	10 AWG	COPPER	THWN	1	3/4"	NOTE 5	EXTERIOR	2,4,5
XC	-	-	-	-	-	-	-	-	-	-	-	-	3

NOTES:

1. MANUFACTURER PROVIDED, UL LISTED WIRING HARNESS FOR USE ON EXPOSED ROOFS
2. CONDUIT SIZE SHOWN IS CODE MINIMUM. LARGER SIZES ARE ALLOWED
3. EXISTING CONDUCTORS, FIELD VERIFY
4. EQUIPMENT TERMINAL RATING SHALL BE A MINIMUM OF 75°C AT BOTH END OF CONDUCTOR
5. PVC, EMT, ROMEX, LFNMC & FMC ARE ACCEPTABLE WHEN USED IN ACCORDANCE WITH ARTICLES 330, 334, 348, 350, 352, 356, & 358 OF THE 2017 NEC

DC/AC INVERTER	
MAKE	SOLAREEDGE
MODEL	SE7600H-US
TECHNOLOGY	TRANS-LESS
DC INPUT:	
MAX. POWER	11800 WATTS
MAX. VOLT	480 VOLTS
NOM. VOLT.	400 VOLTS
MAX. CURRENT	20 AMPS
MAX. SCC	45 AMPS
STRINGS INPUTS	2 STRINGS
AC OUTPUT:	
RATED POWER	7600 WATTS
MAX. POWER	7600 WATTS
NOM. VOLT.	240 VOLTS
MAX. CURR.	32 AMPS
GFP (Y/N)	YES
RPP (Y/N)	YES
GFCI (Y/N)	YES
AFCI (Y/N)	YES
DC DISC. (Y/N)	YES
RAPID SHUTDOWN	AUTOMATIC
FUSE RATING	15 AMPS
PROTECT. RATING	NEMA 4X

AC DISCONNECT	
MAKE	GENERIC
MODEL	N/A
ENCL. RATING	NEMA 3R
VOLT. RATING	240 VOLTS
AMP RATING	60 AMPS
UL LIST. (Y/N)	YES
FUSED (Y/N)	NO
FUSE RATING	N/A

NOTES:

- LOAD-BREAK RATED
- VISIBLE OPEN
- LOCKABLE IN OPEN POSITION
- INSTALL ADJACENT TO METER
- DISCONNECT TO BE READILY ACCESSIBLE TO UTILITY COMPANY PERSONNEL AT ALL TIMES

METER/PANEL COMBO (EXISTING)	
MAKE	N/A
MODEL	N/A
ENCL. RATING	NEMA 3R
VOLT. RATING	240 VOLTS
BUS RATING	200 AMPS
UL LIST. (Y/N)	YES
MAIN BREAKER (Y/N)	YES
BREAKER RATING	200 AMPS

NOTES:

- MAIN BREAKER SERVES AS SERVICE DISCONNECT SWITCH
- BACK-FEED SOLAR OUTPUT VIA (1) 40A BREAKER AT THE OPPOSITE END OF THE BUS BAR FROM THE MAIN BREAKER.

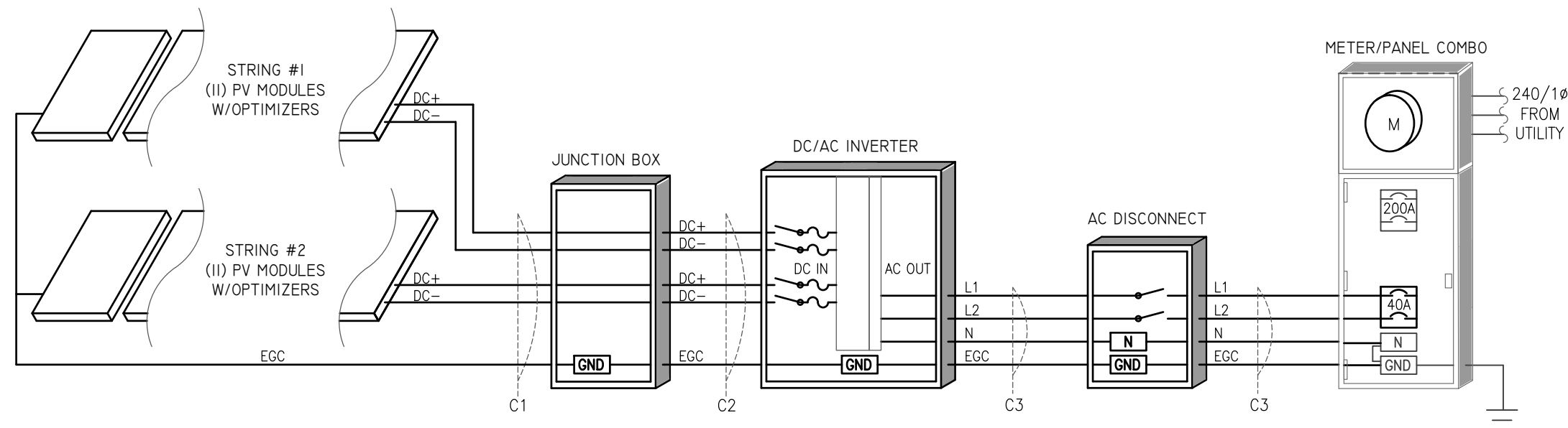

1 PV SYSTEM ELECTRICAL WIRING SCHEMATIC
SCALE: NTS

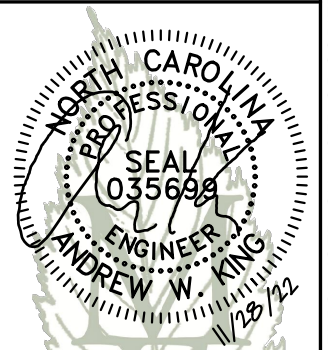

MODEL ENERGY
300 FAYETTEVILLE ST.
#1430
RALEIGH, NC 27602
919-274-9905
MODELENERGY.COM
P-1194

JOB TITLE:

NEW SOLAR PV SYSTEM
8.800 kW DC INPUT
7.600 kW AC EXPORT

Brian Taptick
39 Boone Ct,
Angier, NC 27501

CLIENT:

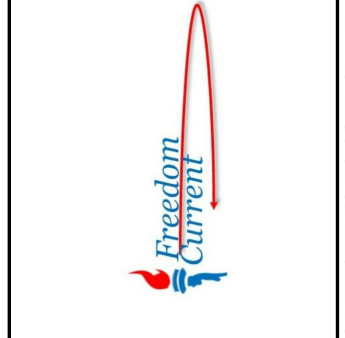

ISSUED FOR: DATE:
CONSTRUCTION v1-11/23/22

ELECTRICAL INFORMATION

PV4.1

© 2022 MODEL ENERGY, PLLC EXPRESSLY RESERVES ITS COMMON LAW COPYRIGHT AND OTHER PROPERTY RIGHTS IN THESE PLANS. THESE PLANS ARE NOT TO BE REPRODUCED, CHANGED OR COPIED IN ANY FORM OR MANNER WHATSOEVER, NOR ARE THEY TO BE ASSIGNED TO ANY THIRD PARTY WITHOUT FIRST OBTAINING THE EXPRESSED WRITTEN PERMISSION AND CONSENT OF MODEL ENERGY, PLLC.

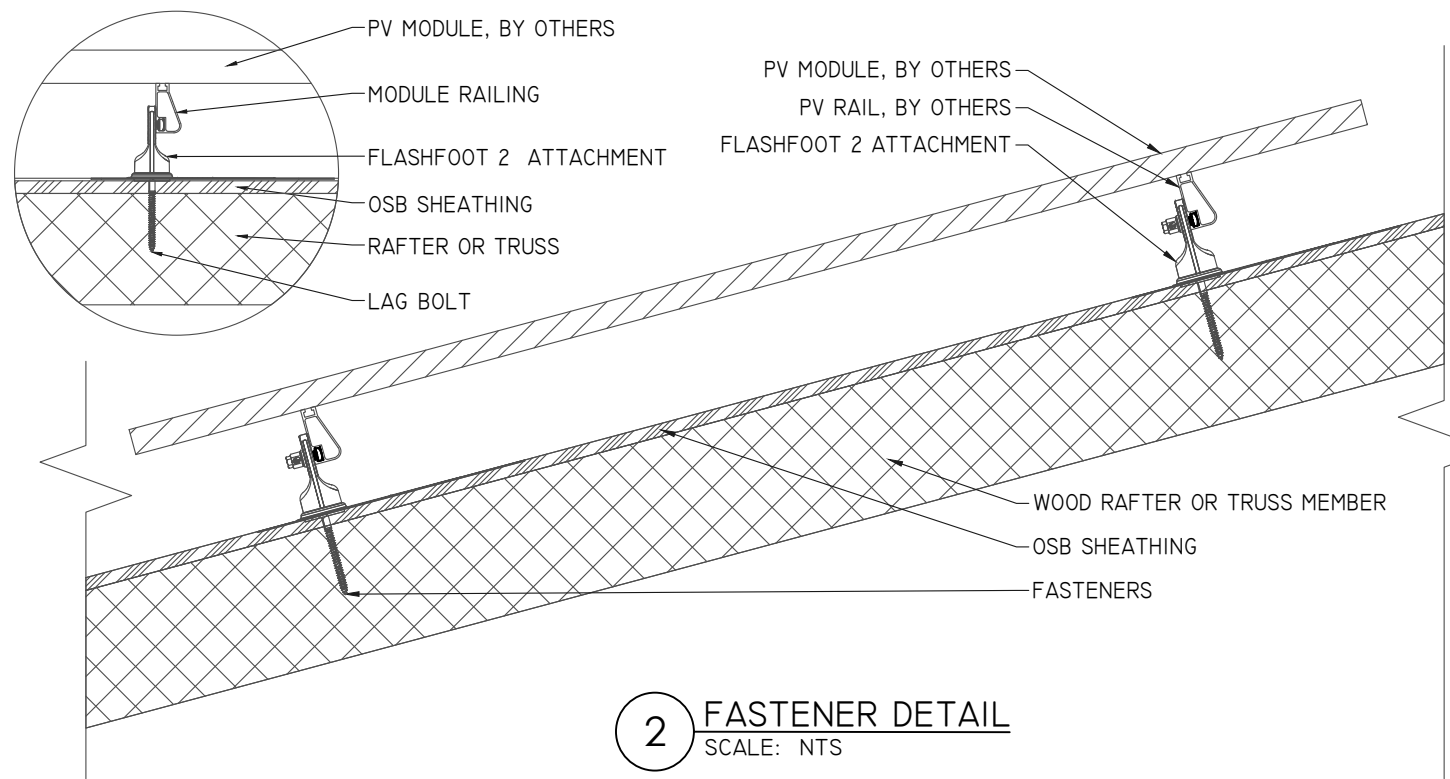

2 FASTENER DETAIL
SCALE: NTS

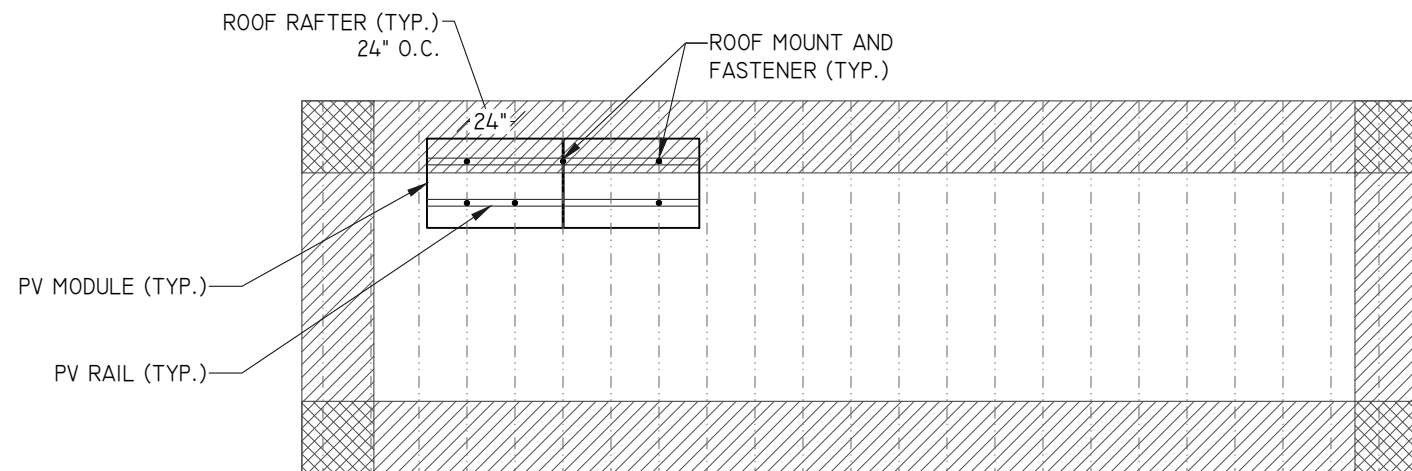

1 ROOF "C" PLANAR VIEW
SCALE: 1/8" = 1' -0"

ARRAY "C" SUMMARY	
# MODULES	2
# ROOF MOUNTS	6
RAIL LENGTH	31 FT.
ARRAY AREA	42 SQFT.
ARRAY WEIGHT	134 LBS.
AZIMUTH @ SN	315°
TILT ANGLE	27°

MOUNTING RAILS	
MAKE	IRONRIDGE
MODEL	XRIO
MATERIAL	ALUMINUM
WEIGHT	1.25 LBS/SQFT
SPACING	34"

PV MODULES	
MAKE	URECO
MODEL	FBM400MFG-BB
WIDTH	44.6"
LENGTH	67.8"
THICKNESS	1.4"
WEIGHT	48 LBS

ROOF "C" ZONES:		
ALL ZONES	MAX. RAIL OVERHANG =	16"
□ ZONE 1	MAX. FASTENER SPAN ZONE 1 =	72"
▨ ZONE 2	MAX. FASTENER SPAN ZONE 2 =	48"
▩ ZONE 3	MAX. FASTENER SPAN ZONE 3 =	24"

STATEMENT OF STRUCTURAL COMPLIANCE

THE EXISTING ROOF STRUCTURE HAS BEEN DESIGNED TO SUPPORT THE ADDITIONAL LOADS OF THE PURPOSED PV SYSTEM. IN ADDITION, THE RACKING AND FASTENING SYSTEM SHALL BE CAPABLE OF SECURING THE SYSTEM TO THE STRUCTURE UNDER DESIGN CONDITIONS WHEN INSTALLED PROPERLY AND IN ACCORDANCE WITH THE RACKING AND FASTENING ARRANGEMENT DETAILED WITHIN THESE DRAWINGS.

SIGNED: 
 NAME: ANDREW W. KING, PE
 TITLE: PROFESSIONAL ENGINEER

ROOF MOUNT & FASTENER	
ROOF MOUNT:	
MAKE	IRONRIDGE
MODEL	FLASHFOOT2
MATERIAL	ALUMINUM
FASTENER	
MAKE	GENERIC
MODEL	LAG BOLT
MATERIAL	304 SS
SIZE	5/16" X 4"
GENERAL	
WEIGHT	1 LBS
FASTENERS PER MOUNT	1 PER MOUNT
MAX. PULL-OUT FORCE	800 LBS.
SAFETY FACTOR	2
DESIGN PULL-OUT FORCE	400 LBS.

- LAG BOLT EMBEDDED WITH 2.5" OF THREAD IN WOOD RAFTER OR TRUSSES MEMBER

ROOF "C" LOADING	
GROUND SNOW LOAD:	15 LBS./SQFT.
LIVE LOAD:	20 LBS./SQFT.
DEAD LOAD:	
ROOFING	3.9 LBS./SQFT.
PV ARRAY	3.0 LBS./SQFT.
TOTAL	6.9 LBS./SQFT.
WIND LOAD:	
UPLIFT ZONE 1	-24.6 LBS/SQFT
UPLIFT ZONE 2	-29.0 LBS/SQFT
UPLIFT ZONE 3	-29.0 LBS/SQFT
DOWNWARD	23.0 LBS/SQFT
FASTENER LOAD:	
UPLIFT ZONE 1	-274 LBS
UPLIFT ZONE 2	-216 LBS
UPLIFT ZONE 3	-108 LBS
DOWNWARD	257 LBS

ROOF "C" SUMMARY	
STRUCTURE:	
TYPE	TRUSS
MATERIAL	SOUTHERN PINE #2
SIZE	2" X 4"
SPACING	24"
EFF. SPAN	13'-10"
PITCH	6/12
DENSITY	30 LBS./CU.FT.
DECKING:	
TYPE	OSB
MATERIAL	WOOD COMPOSITE
THICKNESS	7/16
WEIGHT	1.6 LBS./SQFT.
ROOFING:	
TYPE	ARCH SHINGLE
MATERIAL	ASPHALT
WEIGHT	2.3 LBS./SQFT.

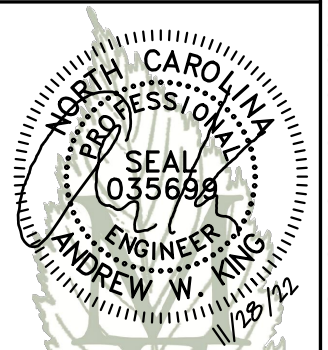

MODEL ENERGY

300 FAYETTEVILLE ST.
#1430
RALEIGH, NC 27602
919-274-9905
MODELENERGY.COM
P-1194

JOB TITLE:

NEW SOLAR PV SYSTEM
8.800 kW DC INPUT
7.600 kW AC EXPORT

Brian Taptick
39 Boone Ct,
Angier, NC 27501

CLIENT:

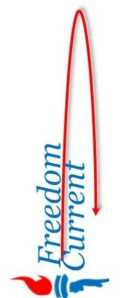

ISSUED FOR: DATE:
CONSTRUCTION v1-11/23/22

STRUCTURAL INFORMATION

PV3.2

© 2022 MODEL ENERGY, PLLC EXPRESSLY RESERVES ITS COMMON LAW COPYRIGHT AND OTHER PROPERTY RIGHTS IN THESE PLANS. THESE PLANS ARE NOT TO BE REPRODUCED, CHANGED OR COPIED IN ANY FORM OR MANNER WHATSOEVER, NOR ARE THEY TO BE ASSIGNED TO ANY THIRD PARTY WITHOUT FIRST OBTAINING THE EXPRESSED WRITTEN PERMISSION AND CONSENT OF MODEL ENERGY, PLLC.



EN



FBM_MFG-BB / 108 cells
390W - 405 W
Mono-Crystalline PV Module

URE Peach module uses URE state-of-the-art cell cutting technology, and advanced module manufacturing experiences.

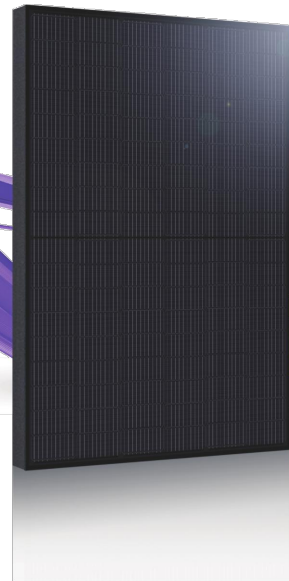

Key Features

- Positive power tolerance +0 ~ +5 watt
- Withstand heavy loading front load 5400 Pa & rear load 2400 Pa
- Excellent low light performance 3.5% relative eff. Reduction at low (200W/m²)
- 100% EL inline inspection Better module reliability
- Design for 1000 VDC Reduce the system BOS effectively



Copyright © 2021 URE Corp. All rights reserved

For more information, please visit us at www.urecorp.com



EN

Electrical Data

Model - STC		FBM390MFG-BB	FBM395MFG-BB	FBM400MFG-BB	FBM405MFG-BB
Maximum Rating Power (Pmax)	[W]	390	395	400	405
Module Efficiency	[%]	19.98	20.23	20.49	20.75
Open Circuit Voltage (Voc)	[V]	36.84	37.03	37.20	37.36
Maximum Power Voltage	[V]	30.82	31.00	31.17	31.36
Short Circuit Current (Isc)	[A]	13.50	13.59	13.68	13.78
Maximum Power Current	[A]	12.66	12.75	12.84	12.92

*Standard Test Condition (STC): Cell Temperature 25 °C, Irradiance 1000 W/m², AM 1.5
*Values without tolerance are typical numbers. Measurement tolerance: ± 3%

Mechanical Data

Item	Specification
Dimensions	1723 mm (L) ¹ x 1133 mm (W) ² x 35 mm (D) ² / 67.83" (L) ¹ x 44.61" (W) ² x 1.38" (D) ²
Weight	21.7 kg / 47.84 lbs
Solar Cell	12x9 pieces monocrystalline solar cells series strings
Front Glass	White toughened safety glass, 3.2mm thickness
Cell Encapsulation	EVA (Ethylene-Vinyl-Acetate)
Frame	Black anodized aluminum profile
Junction Box	IP≥ 68, 3 diodes
Cable & Connector	Potrait : 500 mm (cable length can be customized), 1 x 4 mm ² compatible with MC4
Package Configuration	31 pcs Per Pallet, 806 pcs per 40' HQ container

¹ : With assembly tolerance of ± 2 mm [± 0.08"]
² : With assembly tolerance of ± 0.8 mm [± 0.03"]

Operating Conditions

Item	Specification
Mechanical Load	5400 Pa
Maximum System Voltage	1000V
Series Fuse Rating	30 A
Operating Temperature	-40 to 85 °C

Temperature Characteristics

Item	Specification
Nominal Module Operating Temperature	45°C ± 2°C
Temperature Coefficient of Isc	0.048 % / °C
Temperature Coefficient of Voc	-0.27 % / °C
Temperature Coefficient of Pmax	-0.32 % / °C

*Nominal module operating temperature (NMOT): Air mass AM 1.5, Irradiance 800W/m², temperature 20°C, windspeed 1 m/s.
*Reduction in efficiency from 1000W/m² to 200W/m² at 25°C: 3.5 ± 2%.

Engineering Drawing (mm)

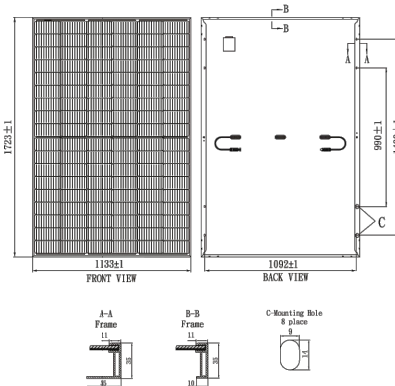

Dependence on Irradiance

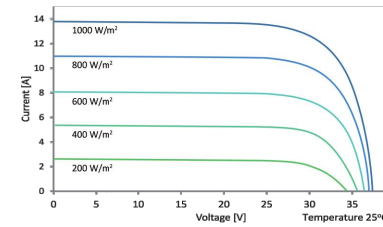

Reliability with Warranty

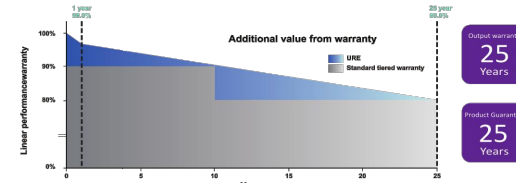

For more information, please visit us at www.urecorp.com

United Renewable Energy Co., Ltd.

Copyright © 2021 URE Corp. All rights reserved

Taipei Office
9F, NO. 295, Sec. 2, Tiding Blvd.,
Neihu Dist., Taipei 11493, Taiwan
Tel : +886-2-2656-2000
Fax : +886-2-2656-0593
e-mail : sales@urecorp.com

Headquarters
No. 7, Li-Hsin 3rd Road, Hsinchu Science Park
Hsinchu city 30078, Taiwan
Tel : +886-3-578-0011
Fax : +886-3-578-1255

URECO_US_Peach_FBM_MFG-BB_V1_3.2_35mm_BS_EN_211019

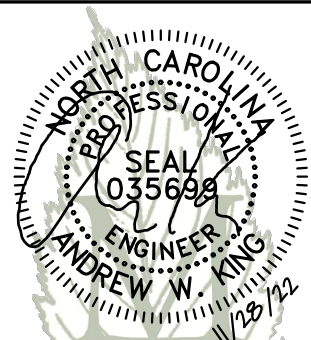

MODEL ENERGY

300 FAYETTEVILLE ST.
#1430
RALEIGH, NC 27602
919-274-9905
MODELENERGY.COM

P-1194

JOB TITLE:

NEW SOLAR PV SYSTEM
8.800 kW DC INPUT
7.600 kW AC EXPORT

Brian Taptick
39 Boone Ct,
Angier, NC 27501

CLIENT:

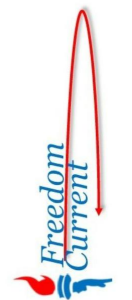

ISSUED FOR: DATE:
CONSTRUCTION v1-11/23/22

LABELS,
DETAILS & SPECS

PV5.1

WARNING: PHOTOVOLTAIC POWER SOURCE

NEC 690.31 (G)(3)&(4)
PLACE ON ALL JUNCTION BOXES, EXPOSED RACEWAYS, AND OTHER WIRING METHODS EVERY 10' AND ON EVERY SECTION SEPARATED BY ENCLOSURES, WALLS, PARTITIONS, CEILINGS, OR FLOORS.

RAPID SHUTDOWN SWITCH FOR SOLAR PV SYSTEM

NEC 690.56 (C)(3)
PLACE ON RAPID SHUTDOWN SWITCH OR EQUIPMENT WITH INTEGRATED RAPID SHUTDOWN *REFLECTIVE*

WARNING

FED BY MULTIPLE POWER SOURCES

TOTAL RATING OF ALL OVERCURRENT DEVICES EXCLUDING UTILITY OVERCURRENT DEVICE SHALL NOT EXCEED AMPACITY OF BUSBAR

NEC 705.12 (B)(2)(3)(c)
PLACE ADJACENT TO BACK-FED BREAKER

EQUIPMENT LABEL NOTES

- LABELS SHOWN ARE 1/2 THEIR ACTUAL REQUIRED SIZE.
- LABEL MATERIAL SHALL BE SUITABLE FOR THE EQUIPMENT ENVIRONMENT.
- CONDUIT SHALL BE MARKED WITH REQUIRED LABEL EVERY 10 FEET.

DIRECT CURRENT PHOTOVOLTAIC POWER SOURCE

MAXIMUM VOLTAGE 600 VDC
MAX CIR. CURRENT 30 AMPS

NEC 690.53
PLACE ON ALL DC DISCONNECTING MEANS

PHOTOVOLTAIC POWER SOURCE
OPERATING AC VOLT. 240 VAC
MAXIMUM OPERATING AC OUTPUT CURRENT 32 AMPS

NEC 690.54
PLACE ON INTERCONNECTION DISCONNECTING MEANS

SOLAR PV SYSTEM EQUIPPED WITH RAPID SHUTDOWN

TURN RAPID SHUTDOWN SWITCH TO THE "OFF" POSITION TO SHUT DOWN PV SYSTEM AND REDUCE SHOCK HAZARD IN THE ARRAY

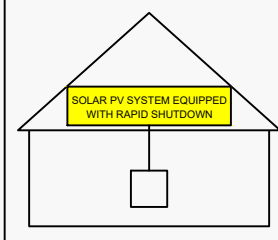

NEC 690.56 (C)(1)(a)
PLACE WITHIN 3FT OF SERVICE DISCONNECTING MEANS TO WHICH THE PV SYSTEMS ARE CONNECTED AND SHALL INDICATE THE LOCATIONS OF RAPID SHUTDOWN SWITCHES

PV SYSTEM DISCONNECT

NEC 690.13 (B)
PLACE ON PV SYSTEM DISCONNECTING MEANS.

WARNING
DUAL POWER SUPPLY
SOURCES: UTILITY GRID AND PV SOLAR ELECTRIC SYSTEM

NEC 705.12 (B)(3)
PLACE ON ALL EQUIPMENT THAT IS SUPPLIED BY BOTH POWER SOURCES

WARNING

ELECTRIC SHOCK HAZARD
TERMINALS ON THE LINE AND LOAD SIDES MAY BE ENERGIZED IN THE OPEN POSITION

NEC 690.13 (B)
PLACE ON PV SYSTEM DISCONNECTING MEANS.

WARNING
POWER SOURCE OUTPUT CONNECTION DO NOT RELOCATE THIS OVERCURRENT DEVICE

NEC 705.12 (B)(2)(3)(b)
PLACE ADJACENT TO BACK-FED BREAKER

Power Optimizer For Residential Installations

S440, S500



POWER OPTIMIZER

Enabling PV power optimization at the module level

- Specifically designed to work with SolarEdge residential inverters
- Mitigates all types of module mismatch loss, from manufacturing tolerance to partial shading
- Detects abnormal PV connector behavior, preventing potential safety issues*
- Faster installations with simplified cable management and easy assembly using a single bolt
- Module-level voltage shutdown for installer and firefighter safety
- Flexible system design for maximum space utilization
- Superior efficiency (99.5%)
- Compatible with bifacial PV modules

* Functionality subject to inverter model and firmware version

solaredge.com



Power Optimizer For Residential Installations S440, S500

	S440	S500	UNIT
Rated Input DC Power ⁽¹⁾	440	500	W
Absolute Maximum Input Voltage (Voc)		60	Vdc
MPPT Operating Range		8 - 60	Vdc
Maximum Short Circuit Current (Isc) of Connected PV Module	14.5	15	Adc
Maximum Efficiency		99.5	%
Weighted Efficiency		98.6	%
Oversoltage Category		II	
OUTPUT DURING OPERATION			
Maximum Output Current		15	Adc
Maximum Output Voltage		60	Vdc
OUTPUT DURING STANDBY (POWER OPTIMIZER DISCONNECTED FROM INVERTER OR INVERTER OFF)			
Safety Output Voltage per Power Optimizer		1	Vdc
STANDARD COMPLIANCE			
EMC	FCC Part 15 Class B, IEC61000-6-2, IEC61000-6-3, CISPR11, EN-55011		
Safety	IEC62109-1 (class II safety), UL1741		
Material	UL94 V-0, UV Resistant		
RoHS	Yes		
Fire Safety	VDE-AR-E 2100-712:2013-05		
INSTALLATION SPECIFICATIONS			
Maximum Allowed System Voltage		1000	Vdc
Dimensions (W x L x H)		129 x 155 x 30	mm
Weight (including cables)		655 / 1.5	gr / lb
Input Connector		MC4 ⁽²⁾	
Input Wire Length		0.1	m
Output Connector		MC4	
Output Wire Length		(+) 2.3, (-) 0.10	m
Operating Temperature Range ⁽³⁾		-40 to +85	°C
Protection Rating		IP68 / NEMA6P	
Relative Humidity		0 - 100	%

(1) Rated power of the module at STC will not exceed the Power Optimizer Rated Input DC Power. Modules with up to +5% power tolerance are allowed
 (2) For other connector types please contact SolarEdge
 (3) For ambient temperature above +70°C / +158°F power de-rating is applied. Refer to Power Optimizers Temperature De-Rating Technical Note for more details

PV System Design Using a SolarEdge Inverter	Single Phase HD-Wave	Three Phase	Three Phase for 277/480V Grid
Minimum String Length (Power Optimizers)	S440, S500	8	16
Maximum String Length (Power Optimizers)		25	50
Maximum Nominal Power per String ⁽⁴⁾		5700	11250 ⁽⁵⁾
Parallel Strings of Different Lengths or Orientations		Yes	12750 ⁽⁶⁾

(4) If the inverters rated AC power < maximum nominal power per string, then the maximum power per string will be able to reach up to the inverters maximum input DC power Refer to: <https://www.solaredge.com/sites/default/files/se-power-optimizer-single-string-design-application-note.pdf>
 (5) For the 230/400V grid: it is allowed to install up to 13,500W per string when the maximum power difference between each string is 2,000W
 (6) For the 277/480V grid: it is allowed to install up to 15,000W per string when the maximum power difference between each string is 2,000W
 (7) It is not allowed to mix S-series and P-series Power Optimizers in new installations

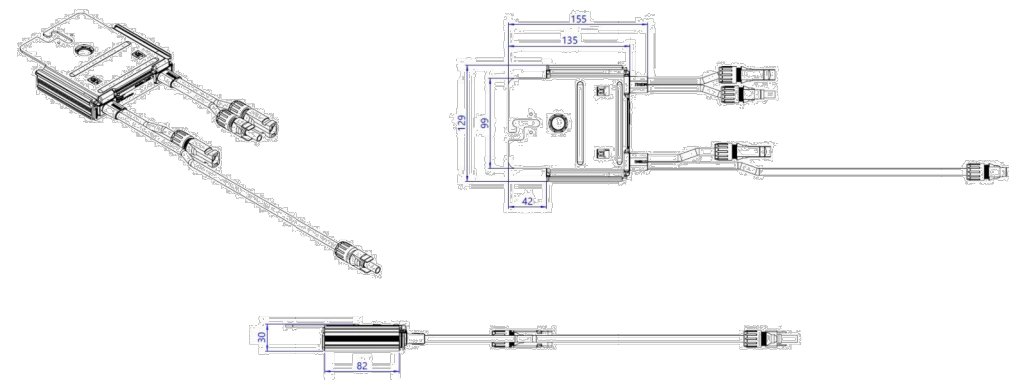

© SolarEdge Technologies, Inc. All rights reserved. SOLAREEDGE, the SolarEdge logo, OPTIMIZED BY SOLAREEDGE are trademarks or registered trademarks of SolarEdge Technologies, Inc. All other trademarks mentioned herein are trademarks of their respective owners. Date: 12/2021 DS-000091-1.2-ENG. Subject to change without notice.

CE RoHS

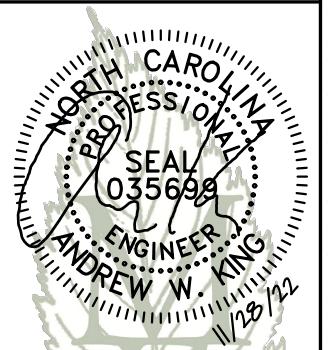

MODEL ENERGY

300 FAYETTEVILLE ST.
#1430
RALEIGH, NC 27602
919-274-9905
MODELENERGY.COM
P-1194

JOB TITLE:

NEW SOLAR PV SYSTEM
8.800 kW DC INPUT
7.600 kW AC EXPORT

Brian Taptick
39 Boone Ct,
Angier, NC 27501

CLIENT:

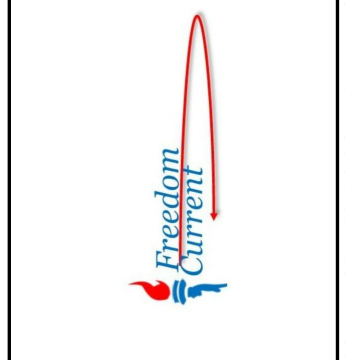

ISSUED FOR: DATE:
CONSTRUCTION V1-11/23/22

EQUIPMENT
SPEC SHEETS

PV5.2

© 2022 MODEL ENERGY, PLLC EXPRESSLY RESERVES ITS COMMON LAW COPYRIGHT AND OTHER PROPERTY RIGHTS IN THESE PLANS. THESE PLANS ARE NOT TO BE REPRODUCED, CHANGED OR COPIED IN ANY FORM OR MANNER WHATSOEVER, NOR ARE THEY TO BE ASSIGNED TO ANY THIRD PARTY WITHOUT FIRST OBTAINING THE EXPRESSED WRITTEN PERMISSION AND CONSENT OF MODEL ENERGY, PLLC.

Single Phase Inverter with HD-Wave Technology

for North America

SE3000H-US / SE3800H-US / SE5000H-US / SE6000H-US / SE7600H-US / SE10000H-US / SE11400H-US



12-25
YEAR
WARRANTY

INVERTERS

Optimized installation with HD-Wave technology

- Specifically designed to work with power optimizers
- Record-breaking efficiency
- Fixed voltage inverter for longer strings
- Integrated arc fault protection and rapid shutdown for NEC 2014 and 2017, per article 690.11 and 690.12
- UL1741 SA certified, for CPUC Rule 21 grid compliance
- Extremely small
- Built-in module-level monitoring
- Outdoor and indoor installation
- Optional: Revenue grade data, ANSI C12.20 Class 0.5 (0.5% accuracy)

solaredge.com



Single Phase Inverter with HD-Wave Technology for North America

SE3000H-US / SE3800H-US / SE5000H-US / SE6000H-US / SE7600H-US / SE10000H-US / SE11400H-US

	SE3000H-US	SE3800H-US	SE5000H-US	SE6000H-US	SE7600H-US	SE10000H-US	SE11400H-US		
OUTPUT									
Rated AC Power Output	3000	3800 @ 240V 3300 @ 208V	5000	6000 @ 240V 5000 @ 208V	7600	10000	11400 @ 240V 10000 @ 208V	VA	
Maximum AC Power Output	3000	3800 @ 240V 3300 @ 208V	5000	6000 @ 240V 5000 @ 208V	7600	10000	11400 @ 240V 10000 @ 208V	VA	
AC Output Voltage Min.-Nom.-Max. (211 - 240 - 264)	✓	✓	✓	✓	✓	✓	✓	Vac	
AC Output Voltage Min.-Nom.-Max. (183 - 208 - 229)	-	✓	-	✓	-	-	✓	Vac	
AC Frequency (Nominal)	59.3 - 60 - 60.5 ⁽¹⁾							Hz	
Maximum Continuous Output Current @240V	12.5	16	21	25	32	42	47.5	A	
Maximum Continuous Output Current @208V	-	16	-	24	-	-	48.5	A	
GFDI Threshold	1							A	
Utility Monitoring, Islanding Protection, Country Configurable Thresholds	Yes								
INPUT									
Maximum DC Power @240V	4650	5900	7750	9300	11800	15500	17650	W	
Maximum DC Power @208V	-	5100	-	7750	-	-	15500	W	
Transformer-less, Ungrounded	Yes								
Maximum Input Voltage	480							Vdc	
Nominal DC Input Voltage	380			400				Vdc	
Maximum Input Current @240V ⁽²⁾	8.5	10.5	13.5	16.5	20	27	30.5	Adc	
Maximum Input Current @208V ⁽²⁾	-	9	-	13.5	-	-	27	Adc	
Max. Input Short Circuit Current	45							Adc	
Reverse-Polarity Protection	Yes								
Ground-Fault Isolation Detection	600k Ω Sensitivity								
Maximum Inverter Efficiency	99	99.2					99 @ 240V 98.5 @ 208V	%	
CEC Weighted Efficiency	99							%	
Nighttime Power Consumption	< 2.5							W	
ADDITIONAL FEATURES									
Supported Communication Interfaces	RS485, Ethernet, ZigBee (optional), Cellular (optional)								
Revenue Grade Data, ANSI C12.20	Optional ⁽³⁾								
Rapid Shutdown - NEC 2014 and 2017 690.12	Automatic Rapid Shutdown upon AC Grid Disconnect								
STANDARD COMPLIANCE									
Safety	UL1741, UL1741 SA, UL1699B, CSA C22.2, Canadian AFCEI according to T.I.L. M-07								
Grid Connection Standards	IEEE1547, Rule 21, Rule 14 (HI)								
Emissions	FCC Part 15 Class B								
INSTALLATION SPECIFICATIONS									
AC Output Conduit Size / AWG Range	1" Maximum / 14-6 AWG				1" Maximum /14-4 AWG				
DC Input Conduit Size / # of Strings / AWG Range	1" Maximum / 1-2 strings / 14-6 AWG				1" Maximum / 1-3 strings / 14-6 AWG				
Dimensions with Safety Switch (HxWxD)	17.7 x 14.6 x 6.8 / 450 x 370 x 174				21.3 x 14.6 x 7.3 / 540 x 370 x 185				in / mm
Weight with Safety Switch	22 / 10	25.1 / 11.4	26.2 / 11.9	38.8 / 17.6				lb / kg	
Noise	< 25				<50				dBA
Cooling	Natural Convection								
Operating Temperature Range	-13 to +140 / -25 to +60 ⁽⁴⁾ (-40°F / -40°C option) ⁽⁵⁾							°F / °C	
Protection Rating	NEMA 4X (Inverter with Safety Switch)								

⁽¹⁾ For other regional settings please contact SolarEdge support
⁽²⁾ A higher current source may be used; the inverter will limit its input current to the values stated
⁽³⁾ Revenue grade inverter P/N: SExxxxH-US000NNC2
⁽⁴⁾ For power de-rating information refer to: <https://www.solaredge.com/sites/default/files/se-temperature-derating-note-na.pdf>
⁽⁵⁾ -40 version P/N: SExxxxH-US000NNU4

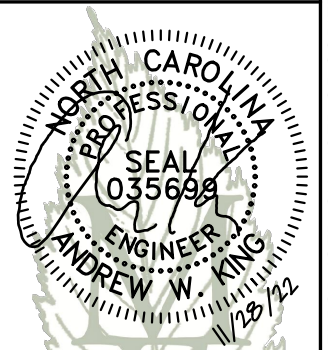

MODEL ENERGY

300 FAYETTEVILLE ST.
#1430
RALEIGH, NC 27602
919-274-9905
MODELENERGY.COM
P-1194

JOB TITLE:

NEW SOLAR PV SYSTEM
8.800 kW DC INPUT
7.600 kW AC EXPORT

Brian Taptick
39 Boone Ct,
Angier, NC 27501

CLIENT:

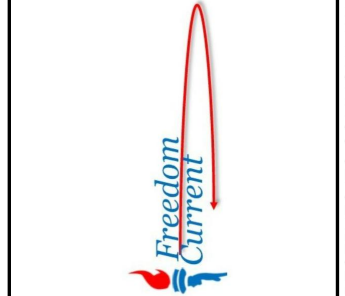

ISSUED FOR: DATE:
CONSTRUCTION V1-11/23/22

EQUIPMENT
SPEC SHEETS

PV5.3

© 2022 MODEL ENERGY, PLLC EXPRESSLY RESERVES ITS COMMON LAW COPYRIGHT AND OTHER PROPERTY RIGHTS IN THESE PLANS. THESE PLANS ARE NOT TO BE REPRODUCED, CHANGED OR COPIED IN ANY FORM OR MANNER WHATSOEVER, NOR ARE THEY TO BE ASSIGNED TO ANY THIRD PARTY WITHOUT FIRST OBTAINING THE EXPRESSED WRITTEN PERMISSION AND CONSENT OF MODEL ENERGY, PLLC.

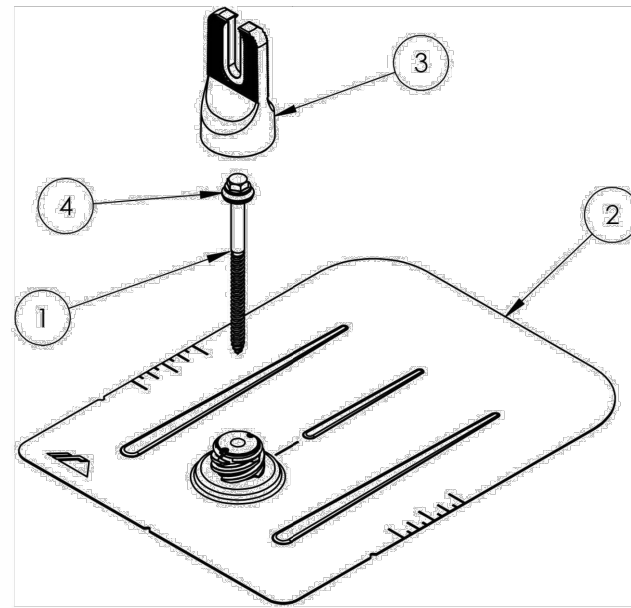

ITEM NO.	DESCRIPTION
1	BOLT LAG 5/16 X 4.75"
2	ASSY, FLASHING
3	ASSY, CAP
4	WASHER, EPDM BACKED

FLASHFOOT 2

Part Number	Description
FF2-01-M1	FLASHFOOT2, MILL
FF2-01-B1	FLASHFOOT2, BLACK

1) Bolt, Lag 5/16 x 4.75"

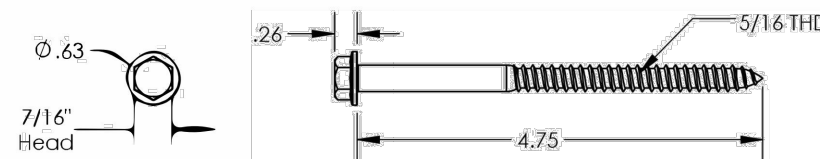

Property	Value
Material	300 Series Stainless Steel
Finish	Clear

v1.21

2) Assy, Flashing

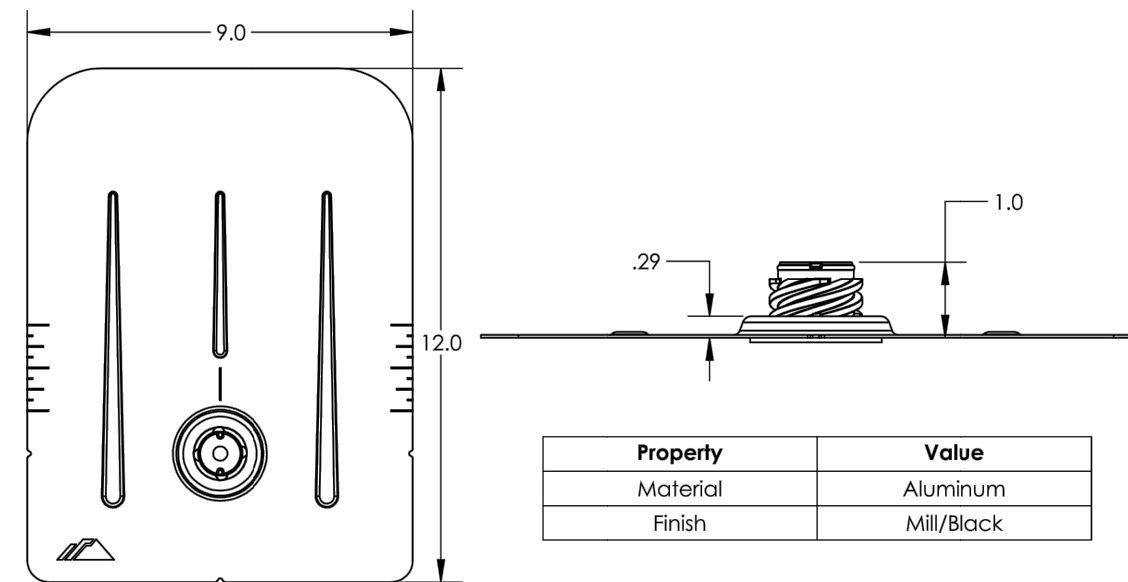

Property	Value
Material	Aluminum
Finish	Mill/Black

3) Assy, Cap

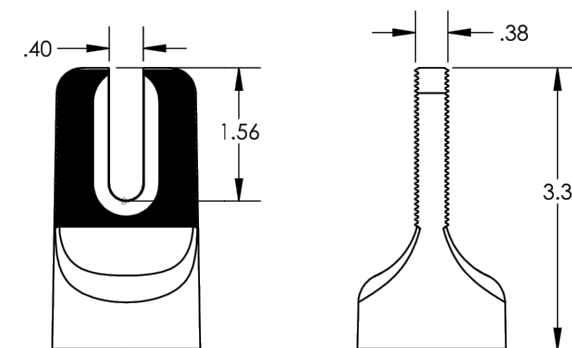

Property	Value
Material	Aluminum
Finish	Mill/Black

4) Washer, EPDM Backed

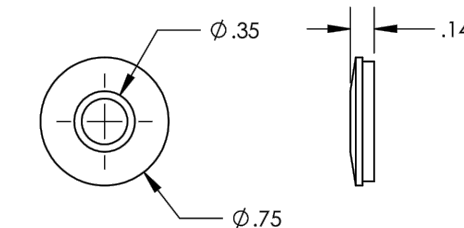

Property	Value
Material	300 Series Stainless Steel
Finish	Clear

v1.21

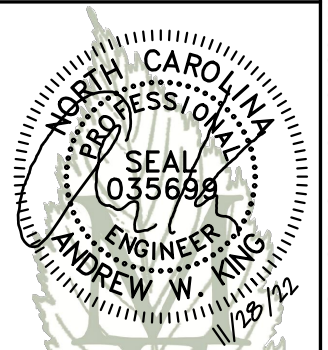

MODEL ENERGY
 300 FAYETTEVILLE ST.
 #1430
 RALEIGH, NC 27602
 919-274-9905
 MODELENERGY.COM
 P-1194

JOB TITLE:
NEW SOLAR PV SYSTEM
 8.800 kW DC INPUT
 7.600 kW AC EXPORT
Brian Taptick
 39 Boone Ct,
 Angier, NC 27501

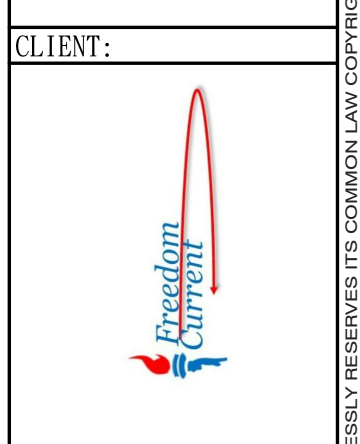

CLIENT:
 ISSUED FOR: DATE:
 CONSTRUCTION v1-11/23/22

EQUIPMENT SPEC SHEETS

PV5.4

Cut Sheet



XR10 Bonded Splice

XR-10 RAIL

12.0

1

2

XR-10-SPLC-M1
XR10 BONDED SPLICE
(INCL. SELF-TAPPING SCREWS)

1) Splice, XR10, Mill 12" long

2) Screw, Self Drilling

#12-14 TYPE "B" THREAD

Property	Value
Material	6000 Series Aluminum
Finish	Mill

Property	Value
Material	300 Series Stainless Steel
Finish	Clear

v1.10

Cut Sheet



XR10 Rail

See Description / Length

Property	Value
Total Cross-Sectional Area	0.363 in ²
Section Modulus (X-axis)	0.136 in ³
Moment of Inertia (X-axis)	0.124 in ⁴
Moment of Inertia (Y-axis)	0.032 in ⁴
Torsional Constant	0.076 in ³
Polar Moment of Inertia	0.033 in ⁴

Clear Part Number	Black Part Number	Description / Length	Material	Weight
XR-10-132A	XR-10-132B	XR10, Rail 132" (11 Feet)	6000-Series Aluminum	4.67 lbs.
XR-10-168A	XR-10-168B	XR10, Rail 168" (14 Feet)		5.95 lbs.
XR-10-204A	XR-10-204B	XR10, Rail 204" (17 Feet)		7.22 lbs.

v1.0

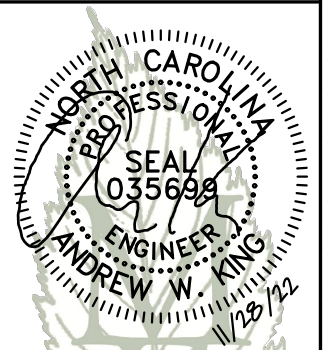

MODEL ENERGY
 300 FAYETTEVILLE ST.
 #1430
 RALEIGH, NC 27602
 919-274-9905
 MODELENERGY.COM
 P-1194

JOB TITLE:

NEW SOLAR PV SYSTEM
 8.800 kW DC INPUT
 7.600 kW AC EXPORT

Brian Taptick
 39 Boone Ct,
 Angier, NC 27501

CLIENT:

ISSUED FOR: CONSTRUCTION
 DATE: v1-11/23/22

EQUIPMENT SPEC SHEETS

PV5.5

© 2022 MODEL ENERGY, PLLC EXPRESSLY RESERVES ITS COMMON LAW COPYRIGHT AND OTHER PROPERTY RIGHTS IN THESE PLANS. THESE PLANS ARE NOT TO BE REPRODUCED, CHANGED OR COPIED IN ANY FORM OR MANNER WHATSOEVER, NOR ARE THEY TO BE ASSIGNED TO ANY THIRD PARTY WITHOUT FIRST OBTAINING THE EXPRESSED WRITTEN PERMISSION AND CONSENT OF MODEL ENERGY, PLLC.

Customer: Brian Taptick
Installer: SmartSun
Subject: PV System Structural Compliance
Date: 11/23/22

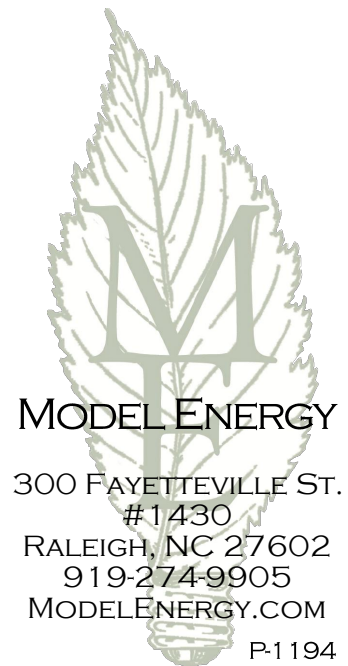

To whom it may concern:

Model Energy, PLLC has reviewed the installation details of the proposed PV system that is to be installed by SmartSun Energy at 39 Boone Ct, Angier, NC 27501. The conditions of the existing structure have been reviewed and validated by Model Energy, PLLC. The existing roof structure has been designed to support the additional loads of the proposed PV system. In addition, the racking and fastening system shall be capable of securing the system to the structure under design conditions when installed properly and in accordance with the racking and fastening arrangement detailed within the accompanying permit set. The installation design is compliant with current 2018 North Carolina state and national building codes.

Thank you,

Andrew King, PE

