

PROJECT DETAILS

PV Modules	33 x SOLARIA POWERXT 400R-PM-AC
Optimizers	33 x P401
Inverter	1 x SE11400H-US(RGM)
Roof Type	Asphalt Shingles
Racking	PSR-B84 Rails (Black)
Mounting Type	CompMount Flashing (Black)
DC SIZE	13.2 kW
AC SIZE	11.4 kVA

DRAWING INDEX

Item	Drawing #	Rev	Description
1	2274KG00-0	A	Drawing Index
2	2274KG00-1	A	Site Layout
3	2274KG00-2	A	String Mapping
4	2274KG00-3	A	Electrical One Line Diagram
5	2274KG00-4	A	Detailed Electrical Wiring Schematic
6	2274KG00-5	A	PV Labels
7	2274KG00-6	A	Bill of Materials
8	2274KG00-7	A	PV Dead Load

TOP VIEW OF BUILDING

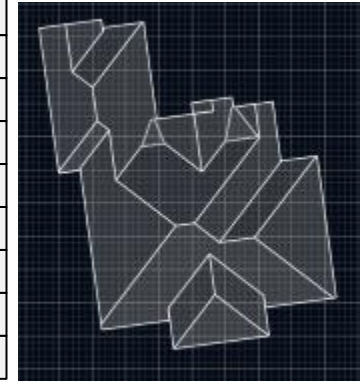

1600 Heritage Commerce Ct Ste 104,
Wake Forest NC 27587
O: 919.948.6474
E: info@8msolar.com

Jeanette L Gallaher
3297 Raynor McLamb Rd,
Linden NC 28356

PHOTOVOLTAIC NOTES

- THE INSTALLATION OF SOLAR ARRAYS AND PHOTOVOLTAIC POWER SYSTEMS SHALL COMPLY WITH THE FOLLOWING CODES:
 - 2020 NORTH CAROLINA RESIDENTIAL CODE
 - 2018 NORTH CAROLINA BUILDING CODE
 - 2017 NATIONAL ELECTRIC CODE
 - AS ADOPTED BY THE STATE OF NORTH CAROLINA
 - ALL OTHER ORDINANCE ADOPTED BY THE LOCAL GOVERNING AGENCIES
- ROOFTOP MOUNTED PHOTOVOLTAIC PANELS AND MODULES SHALL BE TESTED, LISTED AND IDENTIFIED BY RECOGNIZED ELECTRICAL TESTING LABORATORY.
- SOLAR SYSTEM SHALL NOT COVER ANY PLUMBING OR MECHANICAL VENTS
- MODULES AND SUPPORT STRUCTURES SHALL BE GROUNDED
- SOLAR INVERTER SHALL BE LISTED TO UL1741
- ALL CONDUCTORS SHALL BE COPPER AND SHOULD BE 75 AND 90 DEG RATED
- REMOVAL OF AN INTERACTIVE INVERTER OR OTHER EQUIPMENT SHALL NOT DISCONNECT THE BONDING CONNECTION BETWEEN THE GROUNDING ELECTRODE CONDUCTOR AND THE PHOTOVOLTAIC SOURCE AND/OR OUTPUT CIRCUIT GROUNDED CONDUCTORS.
- LIVE PARTS OF PV SOURCE CIRCUITS AND PV OUTPUT CIRCUITS OVER 150V TO GROUND SHALL NOT BE ACCESSIBLE TO OTHER THAN QUALIFIED PERSONS WHILE ENERGIZED.
- ALL PV MODULES AND ASSOCIATED EQUIPMENT AND WIRING SHALL BE PROTECTED FROM PHYSICAL DAMAGE.



A	12/06/2022	_____
_____	_____	_____
_____	_____	_____
_____	_____	_____
_____	_____	_____
_____	_____	_____

JOB NUMBER
22-74-KG00

DATE ISSUED
03/04/2022

PROJECT STATUS
PERMITTING

SHEET

DRAWING INDEX

KG
2274KG00-0

DRAWING INDEX

SCALE: NTS



There is one layer of shingles
Roofing material is asphalt shingles

The roof is located in 120mph wind zone

Utility Meter

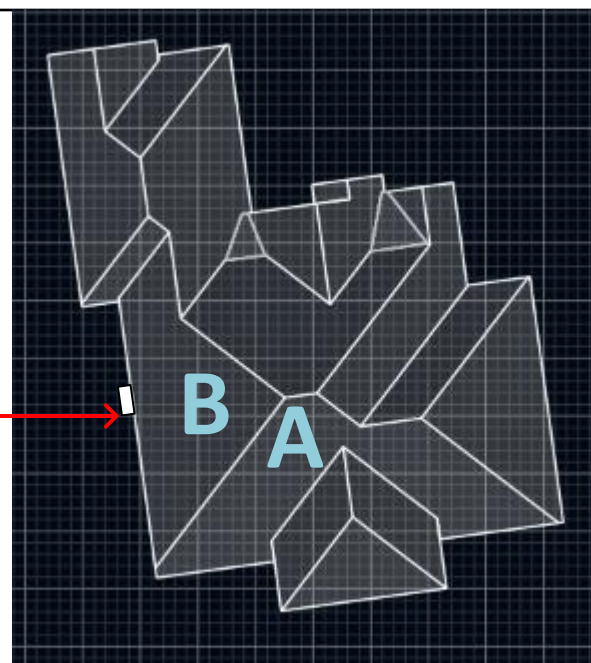

Module Dimension

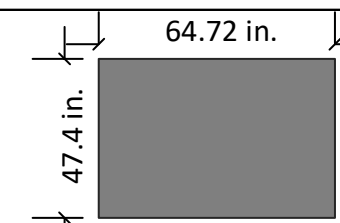

Roofs	Pitch	Azimuth
A	45°	174°
B	45°	262°



1600 Heritage Commerce Ct Ste
104, Wake Forest NC 27587
O: 919.948.6474
E: info@8msolar.com

SYSTEM DETAILS

NUMBER OF PANELS : 33
PANELS MODEL : SOLARIA POWERXT 400R-PM-AC
DC SIZE : 13.2 KW
AC SIZE : 11.4 KVA

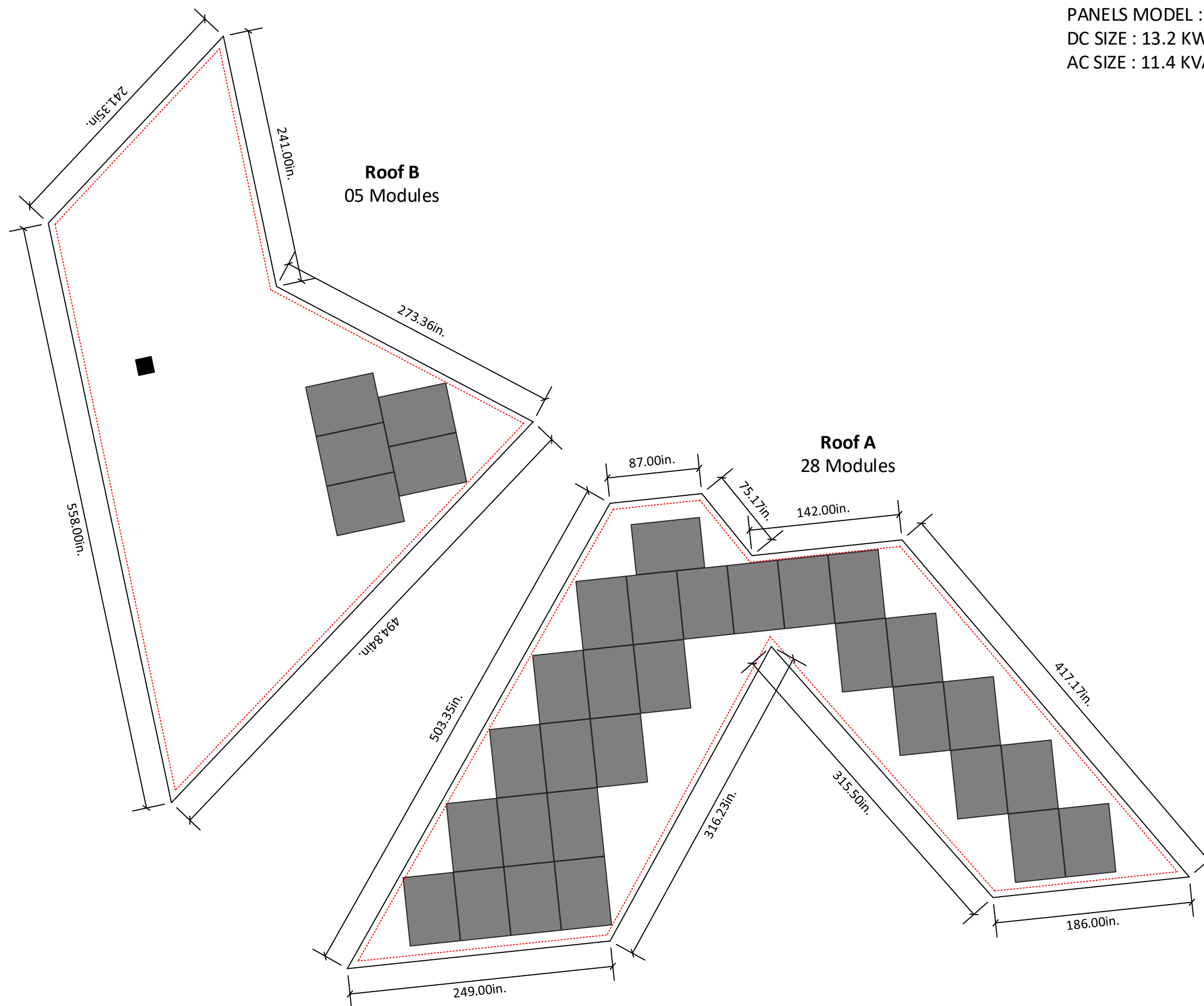

Jeanette L Gallaher
3297 Raynor McLamb Rd,
Linden NC 28356



A 12/06/2022

Customer's Signature

JOB NUMBER
22-74-KG00

PROJECT STATUS
PERMITTING

SHEET
SITE LAYOUT





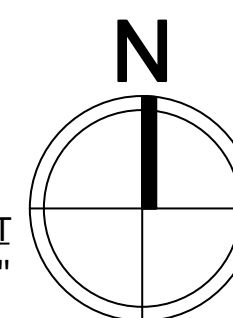

KG
2274KG00-1

SITE LAYOUT
SCALE: 1/8" - 1' 0"



String Layout

Inverter SE11400H-US (RGM)

Strings #	No. of Modules	Color Code	Strings #	No. of Modules	Color Code
String 1	13				
String 2	11				
String 2	09				

Utility Meter

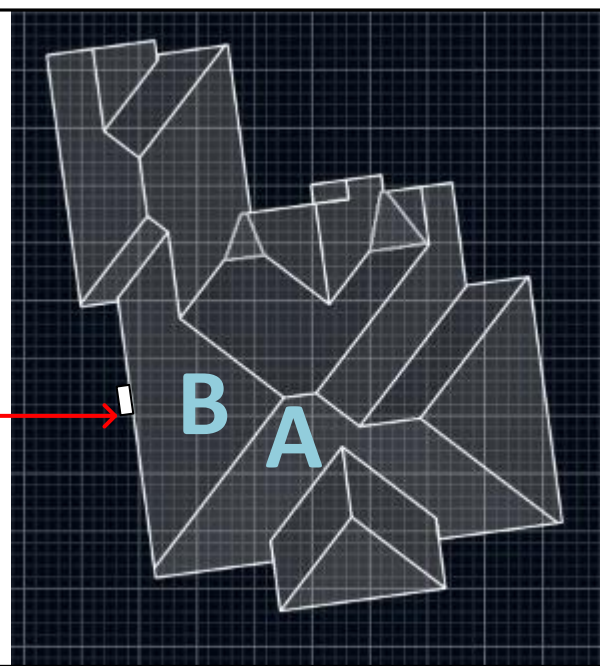

Module Dimension

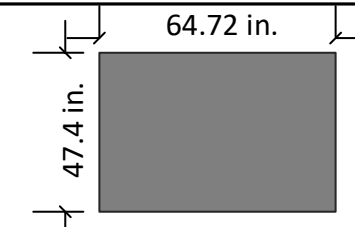

Roofs	Pitch	Azimuth
A	45°	174°
B	45°	262°



1600 Heritage Commerce Ct Ste 104, Wake Forest NC 27587
 O: 919.948.6474
 E: info@8msolar.com

SYSTEM DETAILS

NUMBER OF PANELS : 33
 PANELS MODEL : SOLARIA POWERXT 400R-PM-AC
 DC SIZE : 13.2 KW
 AC SIZE : 11.4 KVA

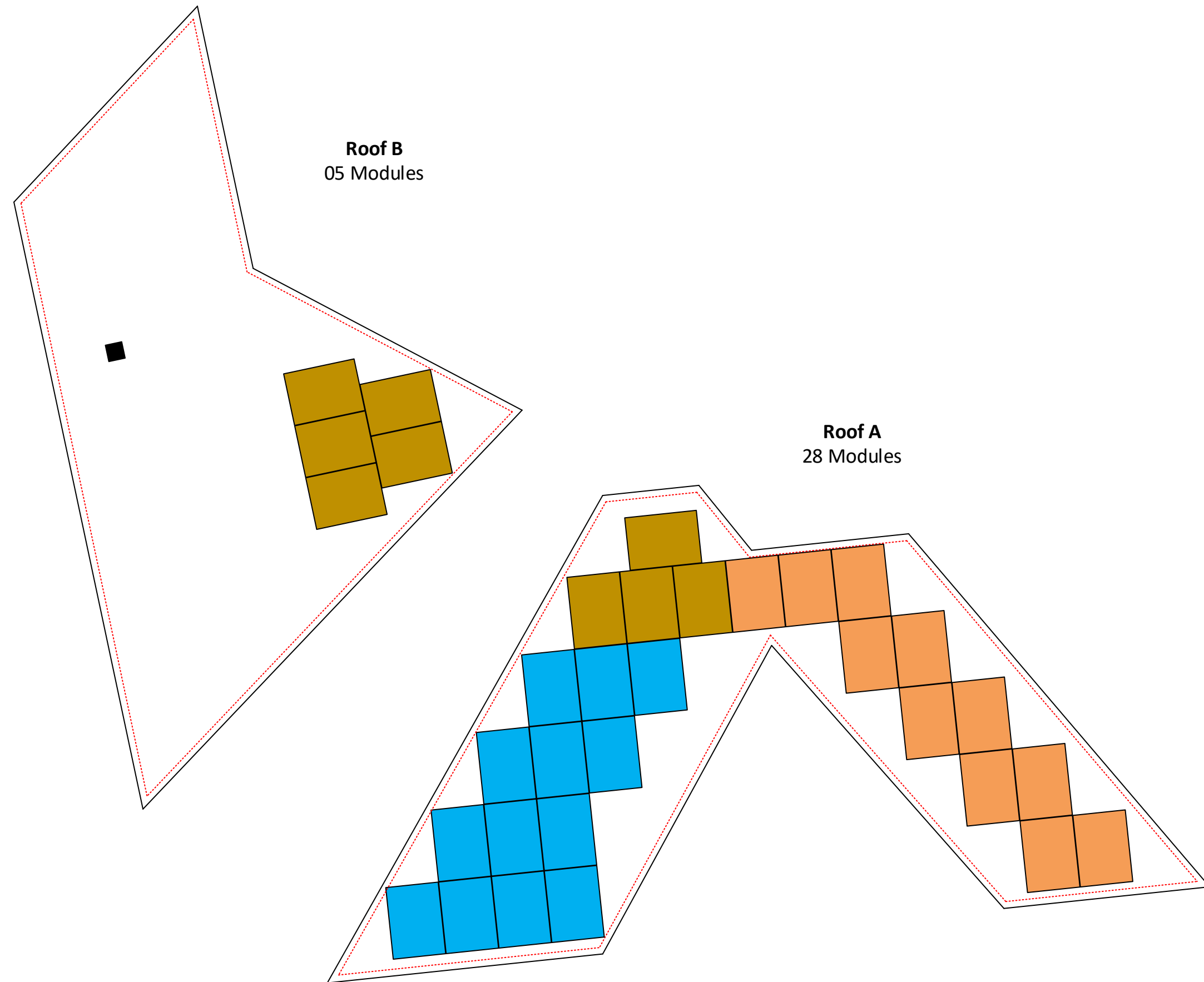

6" clearance from each side of the roof

STRING MAPPING
 SCALE: 1/8" - 1' 0"

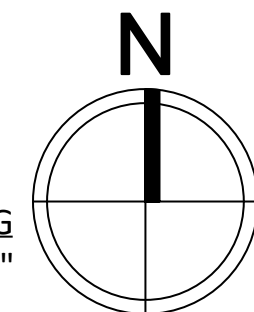

Jeanette L Gallaher
 3297 Raynor McLamb Rd,
 Linden NC 28356



A 12/06/2022

Customer's Signature

JOB NUMBER
 22-74-KG00

PROJECT STATUS
 PERMITTING

SHEET
 STRING MAPPING

KG
 2274KG00-2

Customer's Signature

JOB NUMBER
22-74-KG00

PROJECT STATUS
PERMITTING

SHEET
ELECTRICAL ONE LINE DIAGRAM

KG
2274KG00-3

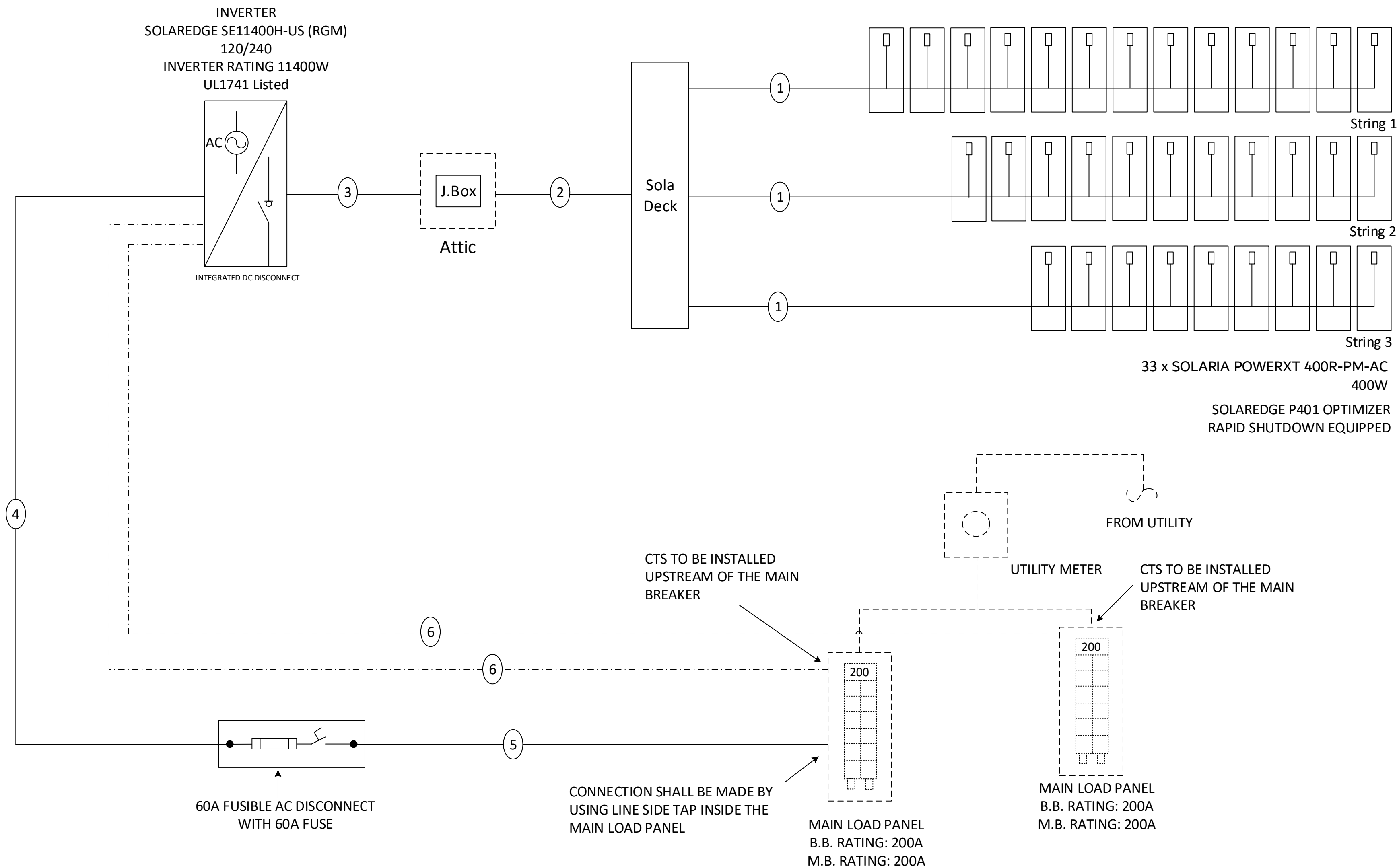

ELECTRICAL NOTES

<ul style="list-style-type: none"> System Size: 13,200W DC (33) SOLARIA POWERXT 400R-PM-AC (33) SOLAREEDGE P401 OPTIMIZERS (01) SOLAREEDGE SE11400H-US (RGM) Output: 47.5A max @ 240 VAC 11.4 kVA AC output max 	<ul style="list-style-type: none"> Grounding will be done via Pegasus grounding lugs, mid-clamps and NS bonding jumpers to ensure the rail and panels are continuously grounded. Rapid Shutdown is included in the Inverter, refer to inverter & optimizer attached datasheets. The load center / disconnect will be visible, lockable accessible to utility linesmen and will be properly labelled as per NEC requirements. It will be located on the exterior wall of the building, next to the utility meter. 	<p>STRING 1: 13 x 400W = 5,200W ea I_{mpp} = 13 Adc I_{max} = 23.4 Adc V_{mpp} = 400 Vdc V_{oc} = 13 Vdc</p>	<p>STRING 2: 11 x 400W = 4,400W ea I_{mpp} = 11 Adc I_{max} = 23.4 Adc V_{mpp} = 400 Vdc V_{oc} = 11 Vdc</p>	<p>STRING 3: 09 x 375W = 3,600W ea I_{mpp} = 09 Adc I_{max} = 23.4 Adc V_{mpp} = 400 Vdc V_{oc} = 09 Vdc</p>	<table border="1"> <thead> <tr> <th>Sr.No</th> <th>#Wire</th> <th>Conduit Size</th> <th>Ground Wire</th> <th>Amperage</th> </tr> </thead> <tbody> <tr> <td>1</td> <td>2 x #10 PV</td> <td></td> <td>#10 Bare CU</td> <td rowspan="3">23.4A</td> </tr> <tr> <td>2</td> <td>3 x #10 MC Cable</td> <td></td> <td></td> </tr> <tr> <td>3</td> <td>6 x #10 THHN Cu</td> <td>3/4" EMT</td> <td>#10 Green</td> </tr> <tr> <td>4</td> <td>3 x #6 THHN Cu</td> <td>1" EMT</td> <td>#08 Green</td> <td>59.37A</td> </tr> <tr> <td>5</td> <td>3 x #6 THHN Cu</td> <td>1" EMT</td> <td></td> <td>59.37A</td> </tr> <tr> <td>6</td> <td>Shielded CAT5e</td> <td></td> <td></td> <td></td> </tr> </tbody> </table>	Sr.No	#Wire	Conduit Size	Ground Wire	Amperage	1	2 x #10 PV		#10 Bare CU	23.4A	2	3 x #10 MC Cable			3	6 x #10 THHN Cu	3/4" EMT	#10 Green	4	3 x #6 THHN Cu	1" EMT	#08 Green	59.37A	5	3 x #6 THHN Cu	1" EMT		59.37A	6	Shielded CAT5e			
		Sr.No	#Wire	Conduit Size	Ground Wire	Amperage																																
1	2 x #10 PV		#10 Bare CU	23.4A																																		
2	3 x #10 MC Cable																																					
3	6 x #10 THHN Cu	3/4" EMT	#10 Green																																			
4	3 x #6 THHN Cu	1" EMT	#08 Green	59.37A																																		
5	3 x #6 THHN Cu	1" EMT		59.37A																																		
6	Shielded CAT5e																																					

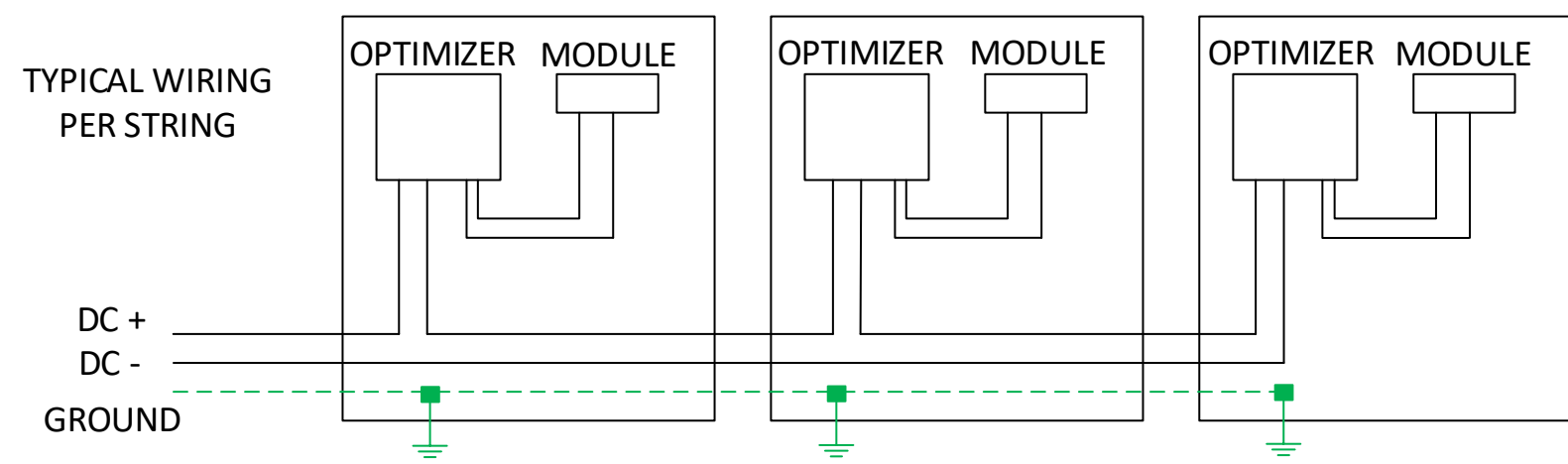

Line 1	
Line 2	
Neutral	
Ground	

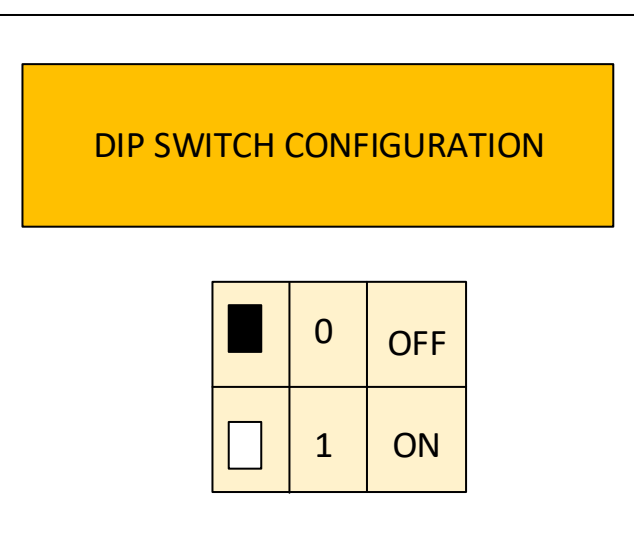

Note

- The arrow on the 225A CTs should face the grid.

Note

- Dip switch settings are factory set to address 1



1600 Heritage Commerce Ct Ste 104, Wake Forest NC 27587
 O: 919.948.6474
 E: info@8msolar.com

Jeanette L Gallaher
 3297 Raynor McLamb Rd,
 Linden NC 28356

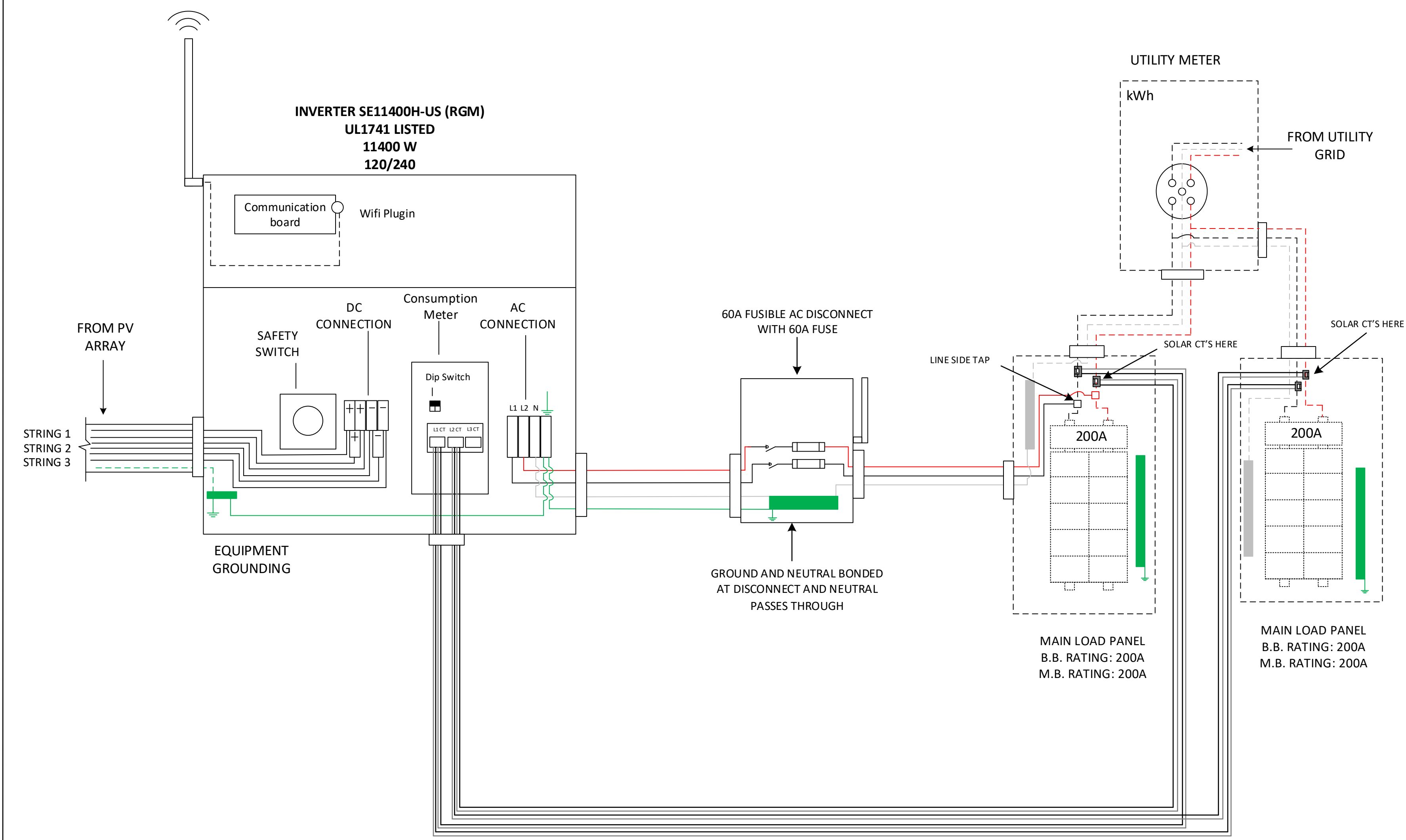

A 12/06/2022

Customer's Signature

JOB NUMBER

22-74-KG00

PROJECT STATUS

PERMITTING

SHEET

DETAILED ELECTRICAL DIAGRAM

KG
 2274KG00-4

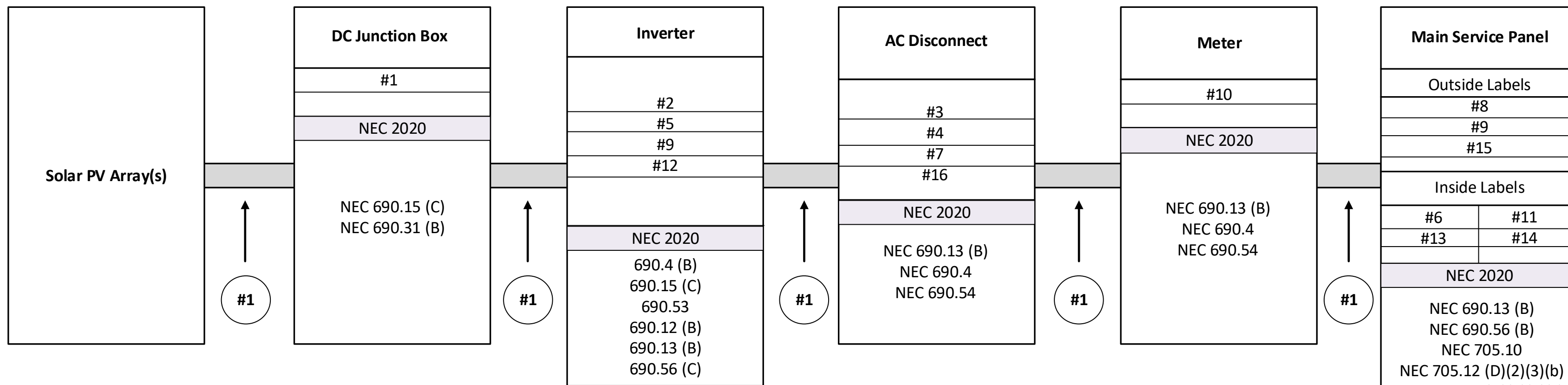

**LABELING AND WARNING SIGNS
NEC 2020**

A. PURPOSE

PROVIDE EMERGENCY RESPONDERS WITH APPROPRIATE WARNING AND GUIDANCE WITH RESPECT TO ISOLATING THE SOLAR ELECTRIC SYSTEM. THIS CAN FACILITATE IDENTIFYING ENERGIZED ELECTRICAL LINES THAT CONNECT THE SOLAR PANELS TO THE INVERTER, AS SHOULD NOT BE CUT WHEN VENTING FOR SMOKE REMOVAL.

B. MAIN SERVICE DISCONNECT:

1. RESIDENTIAL BUILDINGS- THE MARKING MAY BE PLACED WITHIN THE MAIN SERVICE DISCONNECT. THE MARKING SHALL BE PLACED ON THE OUTSIDE COVER IF THE MAIN SERVICE DISCONNECT IS OPERABLE WITH THE SERVICE PANEL CLOSED.

2. COMMERCIAL BUILDINGS- THE MARKINGS SHALL BE PLACED ADJACENT TO THE MAIN SERVICE DISCONNECT CLEARLY VISIBLE FROM THE LOCATION WHERE THE LEVER IS OPERATED

3. MARKINGS, VERBIAGE, FORMAT AND TYPE OF MATERIAL

- a. VERBIAGE: CAUTION; SOLAR ELECTRIC SYSTEM CONNECTED
- b. FORMAT:

- (1) WHITE LETTERING ON A RED BACKGROUND
- (2) MINIMUM 3/8 INCH LETTER HEIGHT
- (3) ALL LETTERS SHALL BE CAPITALIZED
- (4) ARIAL OR SIMILAR FONT, NON-BOLD

c. MATERIAL:

- (1) REFLECTIVE, WEATHER RESISTANT MATERIAL SUITABLE FOR THE ENVIRONMENT (USE UL-969) AS STANDARD FOR WEATHER RATING); DURABLE ADHESIVE MATERIALS MEET THIS REQUIREMENT.

C. MARKING REQUIREMENTS ON DC CONDUIT, RACEWAYS, ENCLOSURES, CABLE ASSEMBLIES, DC COMBINERS AND JUNCTION BOXES;

1. MARKING: PLACEMENT, VERBIAGE, FORMAT AND TYPE OF MATERIAL.

- a. PLACEMENT: MARKINGS SHALL BE PLACED EVERY 10 (TEN) FEET ON ALL INTERIOR AND EXTERIOR DC CONDUITS, RACEWAYS, ENCLOSURES AND CABLE ASSEMBLIES, AT TURNS ABOVE AND/OR BELOW PENETRATIONS, ALL DC COMBINERS AND JUNCTION BOXES.
- b. VERBIAGE: CAUTION SOLAR CIRCUIT
- c. THE FORMAT AND TYPE OF MATERIAL SHALL ADHERE TO SECTION B-3.B & C ABOVE

D. INVERTERS ARE NOT REQUIRED TO HAVE CAUTION MARKINGS

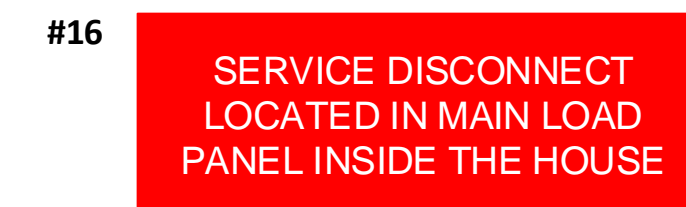
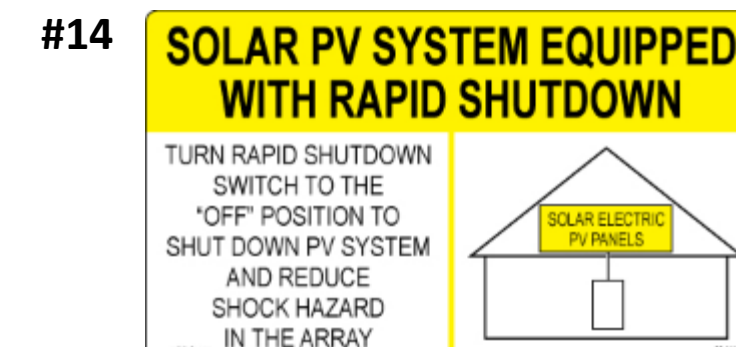
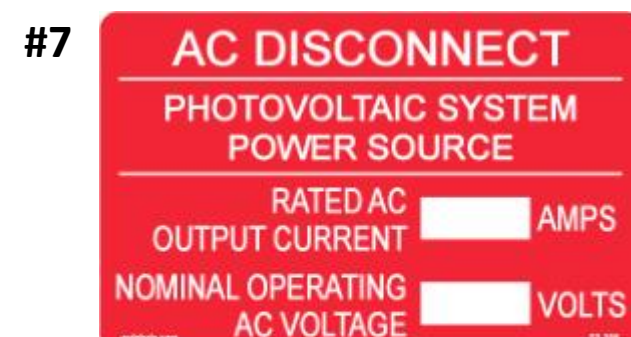

Rails and Splices : PSR-B84 (BLACK)	Roof Attachment : Pegasus Comp Mount
Rafter Spacing : 16 in	There is one layer of shingles Roofing material is asphalt shingles
Attachment Span: 4ft	The roof is located in 120mph wind zone

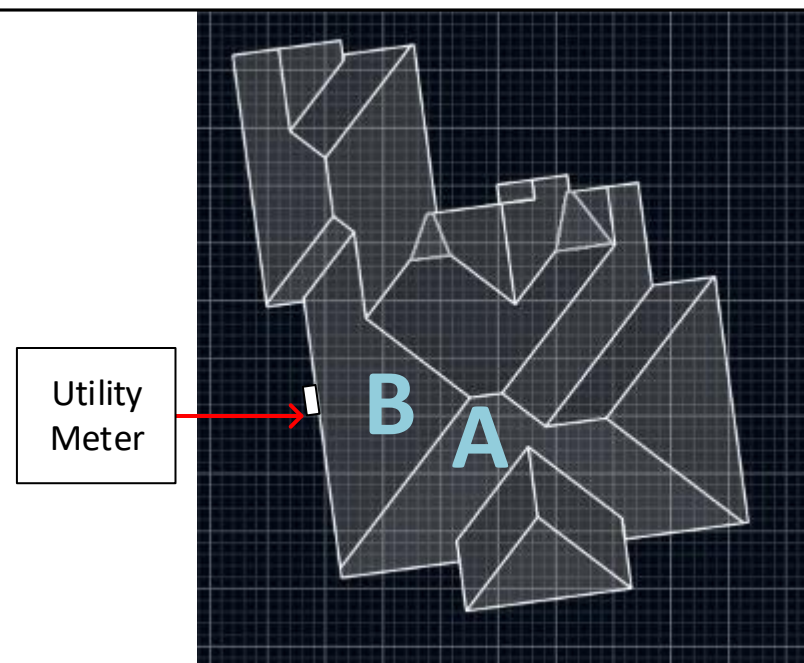

Module Dimension		
	Roofs	Pitch
A	45°	174°
B	45°	262°



1600 Heritage Commerce Ct Ste 104, Wake Forest NC 27587
 O: 919.948.6474
 E: info@8msolar.com

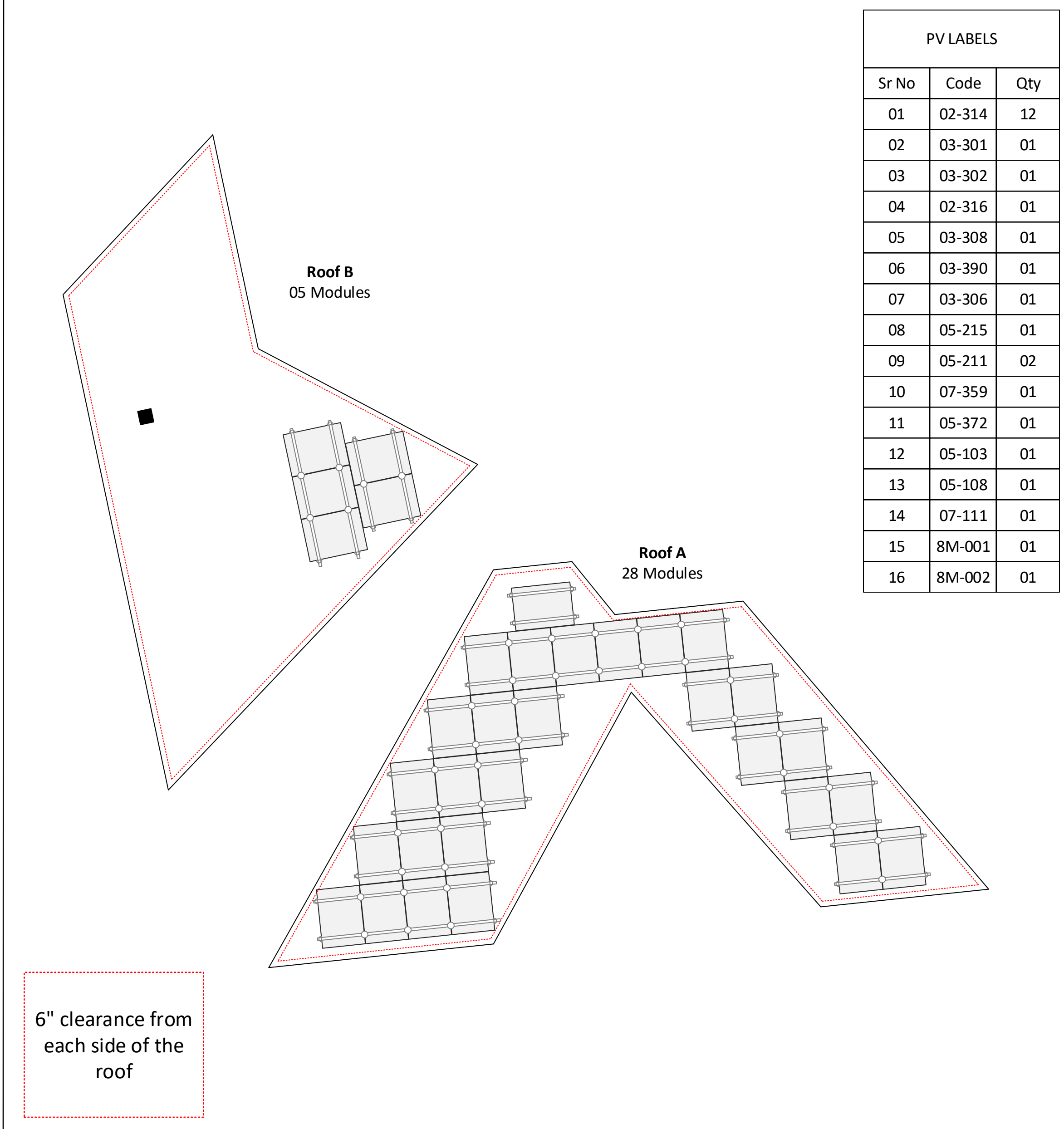

PV LABELS		
Sr No	Code	Qty
01	02-314	12
02	03-301	01
03	03-302	01
04	02-316	01
05	03-308	01
06	03-390	01
07	03-306	01
08	05-215	01
09	05-211	02
10	07-359	01
11	05-372	01
12	05-103	01
13	05-108	01
14	07-111	01
15	8M-001	01
16	8M-002	01

- 52 x PSR-B84: Pegasus Rail, Black, 84" (7 Feet)
- 28 x PSR-SPL: Pegasus - Bonded, Structural Splice
- 42 x PSR-MCB: Pegasus - Multiclamp, Mid/End, 30 to 40 mm, Black
- 48 x PSR-HEC: Pegasus - Hidden End Clamp
- 33 x PSR-MLP: Pegasus - MLPE Mount
- 25 x PSR-LUG: Pegasus - Grounding Lug
- 50 x PSR-WMC: Pegasus - Wire Management Clip
- 06 x PSR-CBG: Pegasus - Cable Grip
- 48 x PSR-CAP: Pegasus - End Cap
- 90 x PSCR-UBBDT: Pegasus Comp Mount - Open Slot, Black L Foot, Black Flashing, Dovetail 3/8" T-Bolt
- 66 x Heyco Wire Clips

- SOLAR MODULES**
- 33 x SOLARIA POWERXT 400R-PM-AC
- INVERTER & SUPPORTING ITEMS**
- 01 x SolarEdge SE11400H-US US000BNI4 (RGM)
 - 33 x SolarEdge Power Optimizer P401
 - 01 x SE-WFGW-B-S1-NA with Antenna kit
 - 04 x SolarEdge 225A CTs
- WIRE**
- 500 ft x #10 PV WIRE BLK (Cu)

Jeanette L Gallaher
 3297 Raynor McLamb Rd,
 Linden NC 28356



A 12/06/2022

Customer's Signature

JOB NUMBER

22-74-KG00

PROJECT STATUS

PERMITTING

SHEET

BILL OF MATERIAL

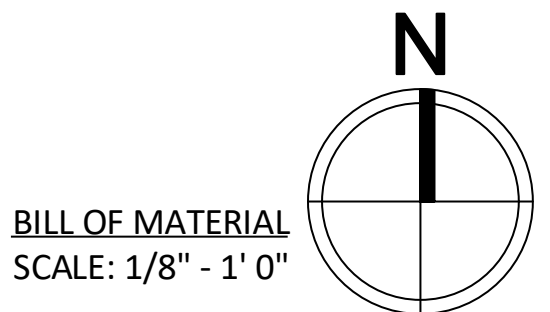

KG
 2274KG00-6

PV System Dead Load
(Panel + Racking weight) / PV System Area
 (No. of panels x Weight of panel(lbs.) +Length of racking(ft.) x 1.17 lb.ft) /
 (No. of panels x Height x Width) = Total psf

The roof is located in 120mph wind zone

There is one layer of shingles
 Roofing material is asphalt shingles

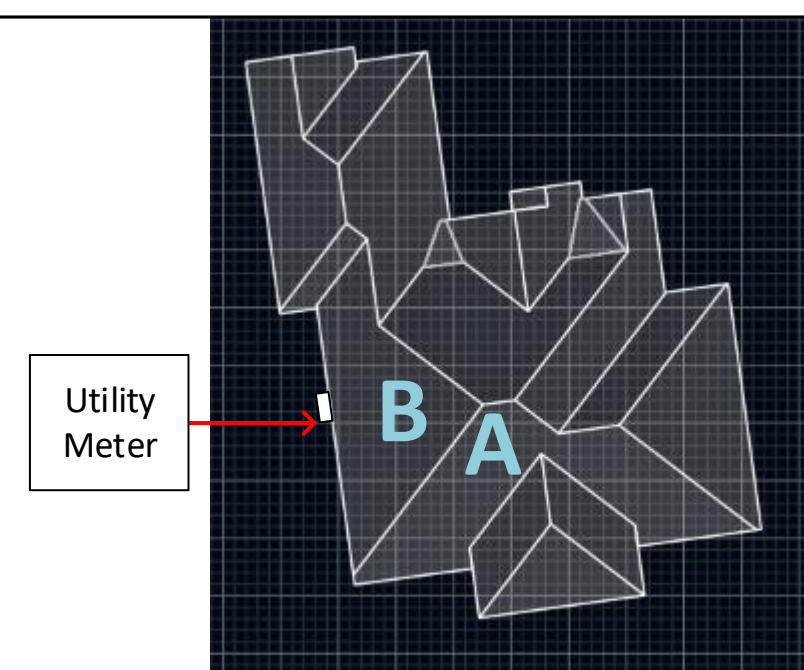

Module Dimension	
Roofs	Pitch Azimuth
A	45° 174°
B	45° 262°

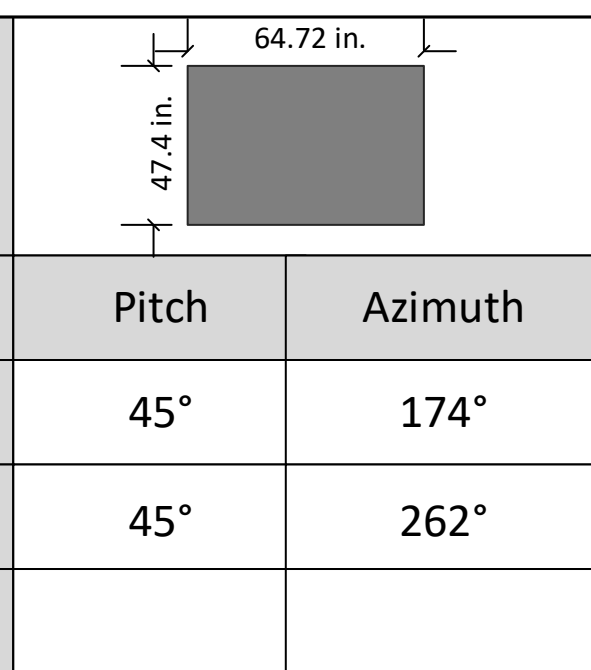

1600 Heritage Commerce Ct Ste
 104, Wake Forest NC 27587
 O: 919.948.6474
 E: info@8msolar.com

Jeanette L Gallaher
 3297 Raynor McLamb Rd,
 Linden NC 28356

ROOF A
<p>PV System Dead Load (Panel + Racking weight) / PV System Area (28 panels x 48 lbs./panel + 223 ft. of racking x 1.17 lb.ft) / (28 panels x 5.393' x 3.95') = 2.59 psf</p>

ROOF B
<p>PV System Dead Load (Panel + Racking weight) / PV System Area (05 panels x 48 lbs./panel + 40 ft. of racking x 1.17 lb.ft) / (05 panels x 5.393' x 3.95') = 2.59 psf</p>



A 12/06/2022

Customer's Signature

JOB NUMBER
22-74-KG00

PROJECT STATUS
PERMITTING

SHEET
PV DEAD LOAD

KG
2274KG00-7

Solaria PowerXT-400R PM

Achieving over 20% efficiency, Solaria PowerXT solar panels are one of the highest power panels in the residential and commercial solar market. Compared to conventional panels, Solaria PowerXT panels have fewer gaps between the solar cells; this leads to higher power and superior aesthetics. Solaria PowerXT Pure Black™ panels are manufactured with black backsheet and frames, enhancing a home or building's architectural beauty.



High Efficiency, High Power

Solaria PowerXT panels achieve up to 20.2% efficiency. Solaria PowerXT panels are one of the highest power panels available.



High Quality and Reliability

Solder-less cell interconnections are highly reliable and designed to far exceed the industry leading 30 year warranty.



Improved Aesthetics

Compared to conventional panels, Solaria PowerXT panels have a more uniform appearance and superior aesthetics.



Lower System Costs

Solaria PowerXT panels produce more power per square meter area. This reduces installation costs due to fewer balance of system components.



Improved Shading Tolerance

Sub-strings are interconnected in parallel, within each of the four panel quadrants, which dramatically lowers the shading losses and boosts energy yield.



PID Resistant

Solaria PowerXT panels are PID resistant. This insures stable and predictable energy production over time.



About Solaria

Established in 2000, The Solaria Corporation has created one of the industry's most respected IP portfolios, with over 250 issued and pending patents in PV solar cell and module technology. Headquartered in California, Solaria has developed a technology platform that unlocks the potential of solar energy.



Performance at STC (1000W/m², 25° C, AM 1.5)

Solaria PowerXT-		400R-PM
Max Power (P _{max})	[W]	400
Efficiency	[%]	20.2
Open Circuit Voltage (V _{oc})	[V]	51.1
Short Circuit Current (I _{sc})	[A]	9.82
Max Power Voltage (V _{mp})	[V]	42.4
Max Power Current (I _{mp})	[A]	9.41
Power Tolerance	[%]	-0/+3

Performance at NOCT (800W/m², 20°C Amb, Wind 1 m/s, AM 1.5)

Max Power (P _{max})	[W]	295
Open Circuit Voltage (V _{oc})	[V]	48.1
Short Circuit Current (I _{sc})	[A]	7.92
Max Power Voltage (V _{mp})	[V]	40.0
Max Power Current (I _{mp})	[A]	7.59

Temperature Characteristics

NOCT	[°C]	45 +/-2
Temp. Coeff. of P _{max}	[% / °C]	-0.39
Temp. Coeff. of V _{oc}	[% / °C]	-0.29
Temp. Coeff. of I _{sc}	[% / °C]	0.04

Design Parameters

Operating temperature	[°C]	-40 to +85
Max System Voltage	[V]	1000
Max Fuse Rating	[A]	20
Bypass Diodes	[#]	4

IV Curves vs. Irradiance (400W Panel)

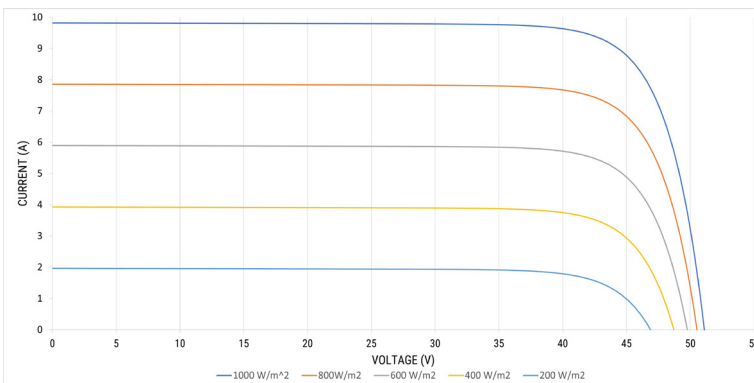

Comprehensive 30-Year Warranty

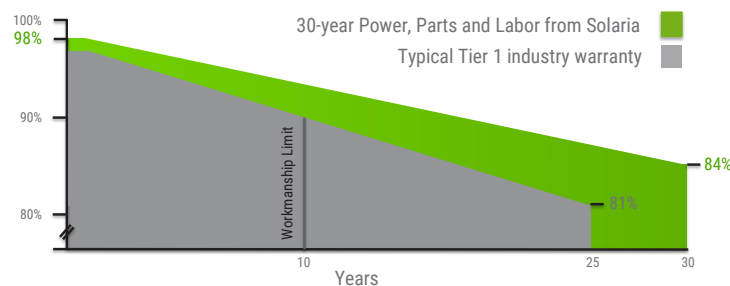

Mechanical Characteristics

Cell Type	Monocrystalline Silicon
Dimensions (L x W x H)	64.72" x 47.4" x 1.57"
	1644mm x 1204mm x 40mm
Weight	21 kg / 46 lbs
Glass Type / Thickness	AR Coated, Tempered / 2.84mm
Frame Type	Black Anodized Aluminum
Cable Type / Length	12 AWG PV Wire (UL) / 1000mm
Connector Type	MC4
Junction Box	IP68 / 4 diodes
Front Load	5400 Pa / 113 psf*
Rear Load	3600 Pa / 75 psf*

* Refer to Solaria Installation Manual for details

Certifications / Warranty

Certifications: UL 61730 / IEC 61215 / IEC 61730
CEC & FSEC Listed

Fire Type (UL 1703): 1

Warranty: 30 years*

* Warranty details at www.solaria.com

Packaging

Stacking Method	Horizontal / Palletized
Panels/ Pallet	25
Pallet Dims (L x W x H)	67.7" x 49.6" x 48.6"
	1720mm x 1260mm x 1235mm
Pallet Weight	575kg / 1268 lbs
Pallets / 40-ft Container	18
Panels / 40-ft Container	450

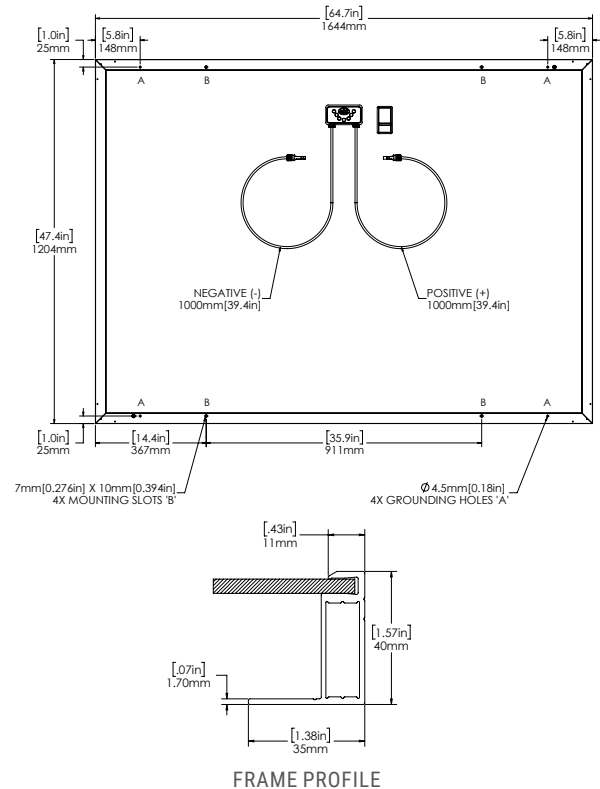

Single Phase Inverter with HD-Wave Technology

for North America

SE3000H-US / SE3800H-US / SE5000H-US / SE6000H-US /
SE7600H-US / SE10000H-US / SE11400H-US



Optimized installation with HD-Wave technology

- / Specifically designed to work with power optimizers
- / Record-breaking 99% weighted efficiency
- / Quick and easy inverter commissioning directly from a smartphone using the SolarEdge SetApp
- / Fixed voltage inverter for longer strings
- / Integrated arc fault protection and rapid shutdown for NEC 2014, NEC 2017 and NEC 2020 per article 690.11 and 690.12
- / UL1741 SA certified, for CPUC Rule 21 grid compliance
- / Small, lightweight, and easy to install both outdoors or indoors
- / Built-in module-level monitoring
- / Optional: Faster installations with built-in consumption metering (1% accuracy) and production revenue grade metering (0.5% accuracy, ANSI C12.20)

/ Single Phase Inverter with HD-Wave Technology for North America

SE3000H-US / SE3800H-US / SE5000H-US / SE6000H-US/
SE7600H-US / SE10000H-US / SE11400H-US

MODEL NUMBER	SE3000H-US	SE3800H-US	SE5000H-US	SE6000H-US	SE7600H-US	SE10000H-US	SE11400H-US	
APPLICABLE TO INVERTERS WITH PART NUMBER	SEXXXXH-XXXXXBXX4							
OUTPUT								
Rated AC Power Output	3000	3800 @ 240V 3300 @ 208V	5000	6000 @ 240V 5000 @ 208V	7600	10000	11400 @ 240V 10000 @ 208V	VA
Maximum AC Power Output	3000	3800 @ 240V 3300 @ 208V	5000	6000 @ 240V 5000 @ 208V	7600	10000	11400 @ 240V 10000 @ 208V	VA
AC Output Voltage Min.-Nom.-Max. (211 - 240 - 264)	✓	✓	✓	✓	✓	✓	✓	Vac
AC Output Voltage Min.-Nom.-Max. (183 - 208 - 229)	-	✓	-	✓	-	-	✓	Vac
AC Frequency (Nominal)	59.3 - 60 - 60.5 ⁽¹⁾							Hz
Maximum Continuous Output Current @240V	12.5	16	21	25	32	42	47.5	A
Maximum Continuous Output Current @208V	-	16	-	24	-	-	48.5	A
Power Factor	1, Adjustable - 0.85 to 0.85							
GFDI Threshold	1							A
Utility Monitoring, Islanding Protection, Country Configurable Thresholds	Yes							
INPUT								
Maximum DC Power @240V	4650	5900	7750	9300	11800	15500	17650	W
Maximum DC Power @208V	-	5100	-	7750	-	-	15500	W
Transformer-less, Ungrounded	Yes							
Maximum Input Voltage	480							Vdc
Nominal DC Input Voltage	380			400				Vdc
Maximum Input Current @240V ⁽²⁾	8.5	10.5	13.5	16.5	20	27	30.5	Adc
Maximum Input Current @208V ⁽²⁾	-	9	-	13.5	-	-	27	Adc
Max. Input Short Circuit Current	45							Adc
Reverse-Polarity Protection	Yes							
Ground-Fault Isolation Detection	600k Ω Sensitivity							
Maximum Inverter Efficiency	99	99.2						%
CEC Weighted Efficiency	99						99 @ 240V 98.5 @ 208V	%
Nighttime Power Consumption	< 2.5							W

(1) For other regional settings please contact SolarEdge support

(2) A higher current source may be used; the inverter will limit its input current to the values stated

/ Single Phase Inverter with HD-Wave Technology for North America

SE3000H-US / SE3800H-US / SE5000H-US / SE6000H-US/
SE7600H-US / SE10000H-US / SE11400H-US

MODEL NUMBER	SE3000H-US	SE3800H-US	SE5000H-US	SE6000H-US	SE7600H-US	SE10000H-US	SE11400H-US	
ADDITIONAL FEATURES								
Supported Communication Interfaces	RS485, Ethernet, ZigBee (optional), Cellular (optional)							
Revenue Grade Metering, ANSI C12.20	Optional ⁽³⁾							
Consumption metering								
Inverter Commissioning	With the SetApp mobile application using Built-in Wi-Fi Access Point for Local Connection							
Rapid Shutdown - NEC 2014, NEC 2017 and NEC 2020, 690.12	Automatic Rapid Shutdown upon AC Grid Disconnect							
STANDARD COMPLIANCE								
Safety	UL1741, UL1741 SA, UL1699B, CSA C22.2, Canadian AFCI according to T.I.L. M-07							
Grid Connection Standards	IEEE1547, Rule 21, Rule 14 (HI)							
Emissions	FCC Part 15 Class B							
INSTALLATION SPECIFICATIONS								
AC Output Conduit Size / AWG Range	1" Maximum / 14-6 AWG				1" Maximum /14-4 AWG			
DC Input Conduit Size / # of Strings / AWG Range	1" Maximum / 1-2 strings / 14-6 AWG				1" Maximum / 1-3 strings / 14-6 AWG			
Dimensions with Safety Switch (HxWxD)	17.7 x 14.6 x 6.8 / 450 x 370 x 174				21.3 x 14.6 x 7.3 / 540 x 370 x 185			
Weight with Safety Switch	22 / 10	25.1 / 11.4	26.2 / 11.9	38.8 / 17.6			lb / kg	
Noise	< 25				<50			dBA
Cooling	Natural Convection							
Operating Temperature Range	-40 to +140 / -40 to +60 ⁽⁴⁾							°F / °C
Protection Rating	NEMA 4X (Inverter with Safety Switch)							

(3) Inverter with Revenue Grade Meter P/N: SExxxH-US000BNC4; Inverter with Revenue Grade Production and Consumption Meter P/N: SExxxH-US000BNI4 . For consumption metering, current transformers should be ordered separately: SEACT0750-200NA-20 or SEACT0750-400NA-20. 20 units per box

(4) Full power up to at least 50°C / 122°F; for power de-rating information refer to: <https://www.solaredge.com/sites/default/files/se-temperature-derating-note-na.pdf>

How to Enable Consumption Monitoring

By simply wiring current transformers through the inverter's existing AC conduits and connecting them to the service panel, homeowners will gain full insight into their household energy usage helping them to avoid high electricity bills

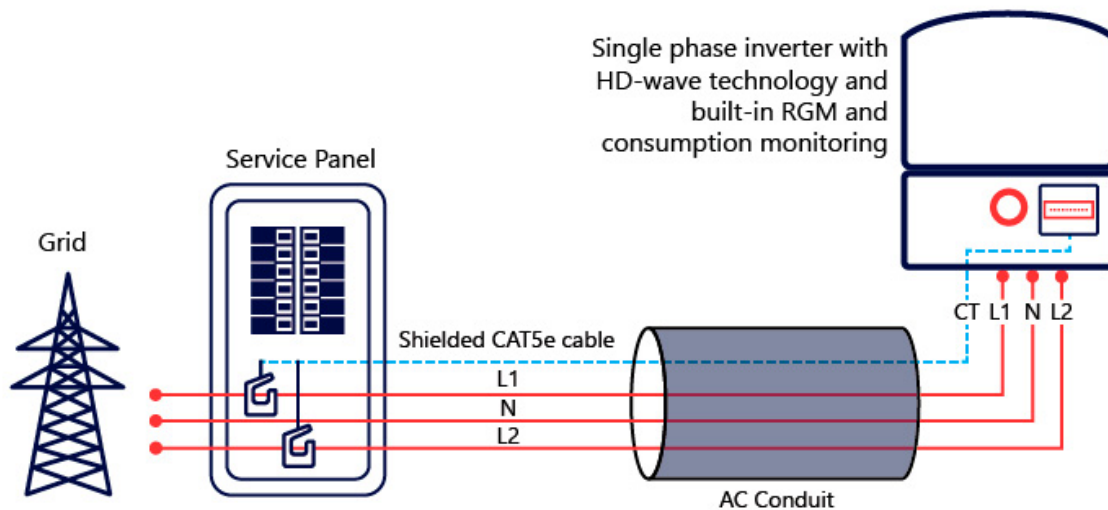

Power Optimizer

For North America

P370 / P400 / P401 / P485 / P505

POWER OPTIMIZER



PV power optimization at the module-level

- Specifically designed to work with SolarEdge inverters
- Up to 25% more energy
- Superior efficiency (99.5%)
- Mitigates all types of module mismatch losses, from manufacturing tolerance to partial shading
- Flexible system design for maximum space utilization
- Fast installation with a single bolt
- Next generation maintenance with module-level monitoring
- Meets NEC requirements for arc fault protection (AFCI) and Photovoltaic Rapid Shutdown System (PVRSS)
- Module-level voltage shutdown for installer and firefighter safety

/ Power Optimizer

For North America

P370 / P400 / P401 / P485 / P505

Optimizer model (typical module compatibility)	P370 (for higher-power 60 and 72-cell modules)	P400 (for 72 & 96- cell modules)	P401 (for high power 60 and 72 cell modules)	P485 (for high-voltage modules)	P505 (for higher current modules)		
INPUT							
Rated Input DC Power ⁽¹⁾	370	400	430	485	505	W	
Absolute Maximum Input Voltage (Voc at lowest temperature)	60	80	60	125 ⁽²⁾	83 ⁽²⁾	Vdc	
MPPT Operating Range	8 - 60	8 - 80	8-60	12.5 - 105	12.5 - 83	Vdc	
Maximum Short Circuit Current (Isc)	11	10.1	12.5	11	14	Adc	
Maximum DC Input Current	13.75	12.5	14.65	12.5	17.5		
Maximum Efficiency						99.5	%
Weighted Efficiency						98.8	%
Overvoltage Category						II	
OUTPUT DURING OPERATION (POWER OPTIMIZER CONNECTED TO OPERATING SOLAREEDGE INVERTER)							
Maximum Output Current						15	Adc
Maximum Output Voltage	60		80			Vdc	
OUTPUT DURING STANDBY (POWER OPTIMIZER DISCONNECTED FROM SOLAREEDGE INVERTER OR SOLAREEDGE INVERTER OFF)							
Safety Output Voltage per Power Optimizer						1 ± 0.1	Vdc
STANDARD COMPLIANCE							
EMC						FCC Part 15 Class B, IEC61000-6-2, IEC61000-6-3	
Safety						IEC62109-1 (class II safety), UL1741, NEC/PVRSS	
Material						UL94 V-0 , UV Resistant	
RoHS						Yes	
INSTALLATION SPECIFICATIONS							
Maximum Allowed System Voltage						1000	Vdc
Compatible inverters						All SolarEdge Single Phase and Three Phase inverters	
Dimensions (W x L x H)	129 x 153 x 27.5 / 5.1 x 6 x 1.1	129 x 153 x 33.5 / 5.1 x 6 x 1.3	129 x 153 x 29.5 / 5.1 x 6 x 1.16	129 x 159 x 49.5 / 5.1 x 6.3 x 1.9	129 x 162 x 59 / 5.1 x 6.4 x 2.3	mm / in	
Weight (including cables)	630 / 1.4	750 / 1.7	655 / 1.5	845 / 1.9	1064 / 2.3	gr / lb	
Input Connector	MC4 ⁽³⁾			MC4 ⁽³⁾	MC4 ⁽³⁾		
Input Wire Length						0.16 / 0.5	m / ft
Output Wire Type / Connector						Double Insulated / MC4	
Output Wire Length						1.2 / 3.9	m / ft
Operating Temperature Range ⁽⁴⁾						-40 to +85 / -40 to +185	°C / °F
Protection Rating						IP68 / Type6B	
Relative Humidity						0 - 100	%

(1) Rated power of the module at STC will not exceed the optimizer "Rated Input DC Power". Modules with up to +5% power tolerance are allowed

(2) NEC 2017 requires max input voltage be not more than 80V

(3) For other connector types please contact SolarEdge

(4) Longer inputs wire lengths are available for use. For 0.9m input wire length order P401-xxxLxxx

(5) For ambient temperature above +85°C / +185°F power de-rating is applied. Refer to Power Optimizers Temperature De-Rating Technical Note for more details: <https://www.solaredge.com/sites/default/files/se-temperature-derating-note-na.pdf>

PV System Design Using a SolarEdge Inverter ⁽⁶⁾⁽⁷⁾	Single Phase HD-Wave	Single phase	Three Phase for 208V grid	Three Phase for 277/480V grid	
Minimum String Length (Power Optimizers)	P370, P400, P401	8	10	18	
	P485, P505	6	8	14	
Maximum String Length (Power Optimizers)	25		25	50	
Maximum Power per String	5700 ⁽⁸⁾ (6000 with SE7600-US - SE11400-US)	5250 ⁽⁸⁾	6000 ⁽⁹⁾	12750 ⁽¹⁰⁾	W
Parallel Strings of Different Lengths or Orientations	Yes				

(6) For detailed string sizing information refer to: http://www.solaredge.com/sites/default/files/string_sizing_na.pdf

(7) It is not allowed to mix P485/P505 with P370/P400/P401 in one string

(8) A string with more than 30 optimizers does not meet NEC rapid shutdown requirements; safety voltage will be above the 30V requirement

(9) For 208V grid: it is allowed to install up to 6,500W per string when the maximum power difference between each string is 1,000W

(10) For 277/480V grid: it is allowed to install up to 15,000W per string when the maximum power difference between each string is 2,000W

Subject: ETL Evaluation of SolarEdge Products to Rapid Shutdown Requirements

To, whom it may concern

This letter represents the testing results of the below listed products to the requirements contained in the following standards:

The evaluation was done on the PV Rapid Shutdown System (PVRSS), and covers installations consisting of optimizers and inverters with part numbers listed below.

The testing done has verified that controlled conductors are limited to:

- Not more than 30 volts and 240 voltamperes within 30 seconds of rapid shutdown initiation outside the array.
- Not more than 80 volts and 240 voltamperes within 30 seconds of rapid shutdown initiation inside the array.

The rapid shutdown initiation is performed by either disconnecting the AC feed to the inverter, or – if the inverter DC Safety switch is readily accessible – by turning off the DC Safety switch.

Applicable products:

(1) Power optimizers:

PB followed by 001 to 350; followed by -AOB or -TFI.

OP followed by 001 to 500; followed by -LV, -MV, -IV or -EV.

P followed by 001 to 1100.

SP followed by 001 to 350.

When optimizers are connected to 2 or more modules in series, the max input voltage may exceed 80V. Following the implementation of the NEC 2017 rapid shutdown value of 80V max inside of the array at the beginning of 2019, modules exceeding this combined input max voltage will be required to use optimizers with parallel inputs. Also meeting NEC 2020 rapid shutdown requirement.

(2) 1 -PH Inverters

SE3000A-US / SE3800A-US / SE5000A-US / SE6000A-US / SE7600A-US / SE10000A-US / SE11400A-US / SE3000H-US / SE3800H-US / SE5000H-US / SE6000H-US / SE7600H-US / SE10000H-US / SE11400H-US when the following label is labeled on the side of the inverter:

Inverter part number may be followed by a suffix.

(3) 3 -PH Inverters



Total Quality. Assured.

Intertek
3933 US Route 11
Cortland, NY 13045
Telephone: 607-753-7311
www.intertek.com

SE9KUS / SE10KUS / SE14.4KUS/ SE16.7kUS / SE17.3kUS / SE20KUS/ SE24KUS / SE30KUS / SE33.3KUS / SE40KUS / SE43.2KUS / SE50KUS / SE66.6KUS / SE80KUS / SE85KUS / SE100KUS / SE120KUS; when the following label is labeled on the side of the inverter:

Please note, this Letter Report does not represent authorization for the use of any Intertek certification marks.

Brand Name(s)	SolarEdge
Relevant Standard(s)	UL 1741, UL 1741 CRD for rapid shutdown National Electric Code, 2020, Section 690.12 requirement for rapid shutdown
Verification Issuing Office	3933 US Route 11, Cortland, NY 13045

NRTL Disclaimer, Different for each NRTL – Example: *"This Verification is for the exclusive use of NRTL's Client and is provided pursuant to the agreement between NRTL and its Client. NRTL's responsibility and liability are limited to the terms and conditions of the agreement. NRTL assumes no liability to any party, other than to the Client in accordance with the agreement, for any loss, expense or damage occasioned by the use of this Verification. Only the Client is authorized to copy or distribute this Verification. Any use of the NRTL name or one of its marks for the sale or advertisement of the tested material, product or service must first be approved in writing by NRTL. The observations and test results referenced from this Verification are relevant only to the sample tested. This Verification by itself does not imply that the material, product, or service is or has ever been under an NRTL certification program."*

Signature: 

Name: Mukund Rana
Position: Staff Engineer
Date:5/17/2021

Date	Engineer / Reviewer	Description
5/17/2021 G104683664CRT	Dishant Patel Mukund Rana	Added New 3-PH Inverter model SE50KUS, SE80KUS, SE85KUS and SE120KUS. Updated Power optimizers from "P followed by 001 to 960" to "P followed by 001 to 1100" Updated NEC standard from "National Electric Code, 2017, Section 690.12 requirement for rapid shutdown" To "National Electric Code, 2020, Section 690.12 requirement for rapid shutdown"

One Clamp Anywhere

The Multi-Clamp works as mid- or end-clamp, and fits standard 30-40mm frames.

Instant Bonding

The N-S Bonding Jumper bonds row to row with no tools.

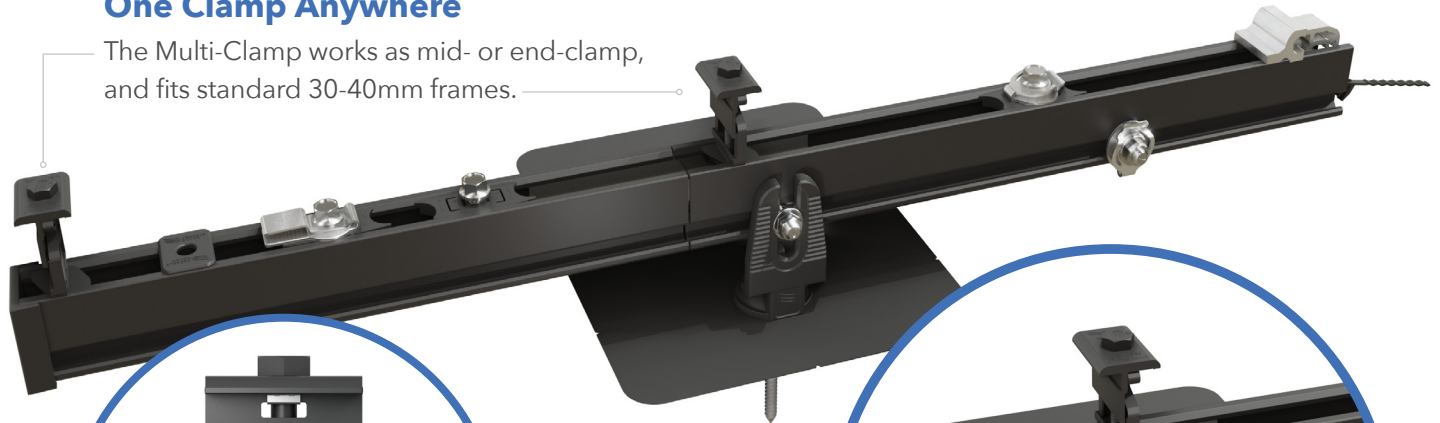

Lifetime Wire Management

Open rail channel holds and protects wires. Clamps won't pinch wires after tightening.

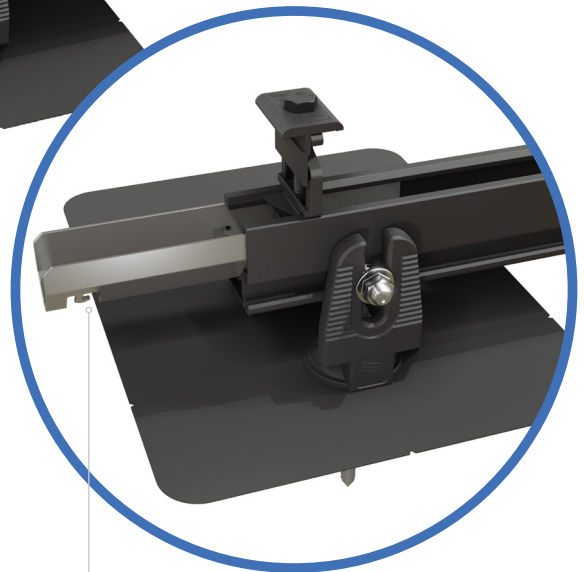

Bonding Structural Splice

Connect rails instantly, without tools, interference or limitations.

Next-Level Solar Mounting

A complete system for hassle-free rooftop installation, from watertight mounts to lifetime wire management.



Simplicity

1/2" socket for everything.
One clamp for mid or end.
No tool splicing and bonding.
Easy wire management.



Code Compliant

UL 2703 listed
LTR-AE-001-2012 listed
Class A fire rating for any slope
ASCE 7-16 PE Certified



Premium Aesthetics

The narrowest panel gap available. Optional Hidden End Clamps and End Caps provide a flush look on the edge of the array.



Watertight for Life

Secured on industry-leading Pegasus Mounts, for composite shingle and tile roofs. Backed by a 25-year warranty.

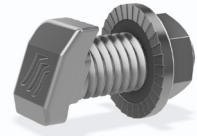
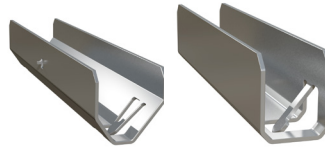
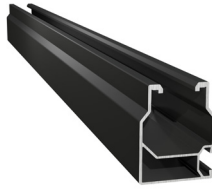

Pegasus Rail	Pegasus Max Rail	Splice and Max Splice	Dovetail T-bolt
--------------	------------------	-----------------------	-----------------

Available in 14' and 7' lengths for easy layout and shipping.
Open-channel design holds MC4 connectors, PV wire and trunk cables.
Black and Mill finish

Maximum-strength design.
Meets specifications for high snow-load and hurricane zones.
Black and Mill finish

Installs by hand.
Works over mounts.
Structurally connects and bonds rails automatically; UL2703 listed as reusable.

Dovetail shape for extra strength.
Uses 1/2" socket.



Multi-Clamp	Hidden End Clamp	Ground Lug	N-S Bonding Jumper
-------------	------------------	------------	--------------------

Fits 30-40mm PV frames, as mid- or end-clamp.
Twist-locks into position; doesn't pinch wires in rail.
Bonds modules to rail; UL2703 listed as reusable

Offers premium edge appearance.
Preinstalled pull-tab grips rail edge, allowing easy, one-hand installation.
Tucks away for reuse.

Holds 6 or 8 AWG wire.
Mounts on top or side of rail.
Assembled on MLPE Mount.
UL2703 listed as reusable.

Installs by hand, eliminates row-to-row copper wire.
UL2703 listed as reusable only with Pegasus Rail.

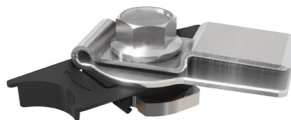
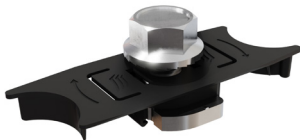

MLPE Mount	Cable Grip	Wire Clip	End Cap and Max End Cap
------------	------------	-----------	-------------------------

Secures and bonds most micro-inverters and optimizers to rail.
Connectors and wires easily route underneath after installation.
UL2703 listed as reusable.

Secures four PV wires or two trunk cables.
Stainless-steel backing provides durable grip.
Eliminates sagging wires.

Hand operable.
Holds wires in channel.
Won't slip.

Fits flush to PV module and hides raw or angled cuts.
Hidden drain quickly clears water from rail.

Certifications:

- UL 2703, Edition 1
- LTR-AE-001-2012
- ASCE 7-16 PE certified
- Class A fire rating for any slope roof



Quickly calculate the most efficient layout, spans and materials needed to suit your job. Visit the Pegasus Customer Portal. pegasussolar.com/portal

LOAD		SPAN			
SNOW (PSF)	WIND (MPH)	32"	4'	6'	8'
0	120	PEGASUS RAIL			
	160	PEGASUS RAIL			PEGASUS MAX RAIL
	190	PEGASUS RAIL		PEGASUS MAX RAIL	
15	140	PEGASUS RAIL			PEGASUS MAX RAIL
	160	PEGASUS RAIL		PEGASUS MAX RAIL	
30	160	PEGASUS RAIL		PEGASUS MAX RAIL	
	190	PEGASUS RAIL		PEGASUS MAX RAIL	
45	190	PEGASUS RAIL		PEGASUS MAX RAIL	
70	190	PEGASUS RAIL		PEGASUS MAX RAIL	
110	190	PEGASUS RAIL		PEGASUS MAX RAIL	

For reference only. Spans above are calculated using ASCE 7-16 for a Gable Roof, Exposure Category B, 7-20deg roof angle, 30ft mean roof height with non-exposed modules. For PE certified span tables, visit www.pegasussolar.com/spans.

Patents pending. All rights reserved. ©2021 Pegasus Solar Inc.

COMP MOUNT

One-Piece Flashing with Elevated Cone

No press-fits or deck-level EPDM washers to fail

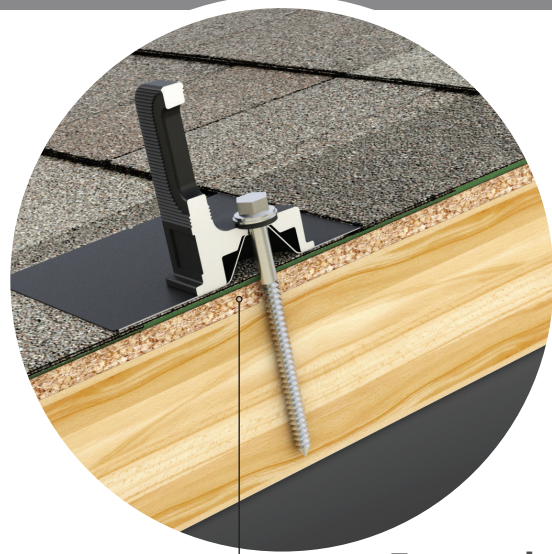

Encapsulating Design

Raises the water seal 0.9" Above roof deck



Simple 3-Piece Design Watertight For Life

Pegasus solar's comp mounts are a cost effective, high-quality option for rail installations on composition shingle roofs. Designed to last decades, the one-piece flashing with elevated cone means there is simply nothing to fail.



25-Year Warranty

Manufactured with advanced materials and coatings to outlast the roof itself



Code Compliant

Fully IBC/CBC Code Compliant
Exceeds ASCE 7-16 Standards



Superior Waterproofing

Tested to AC286 without sealant
Water seal elevated 0.9" above



All-In-One Kit Packaging

Flashings, L-Feet and SS lags with bonded EPDM washers are included in each 24-pack

1

Drill pilot hole in the center of the rafter.

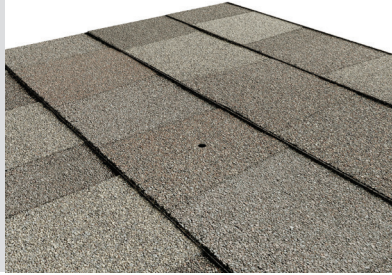

2

Optional: Apply a "u-shape" of sealant to the underside of the flashing and position under 2nd shingle course, cone over pilot hole.

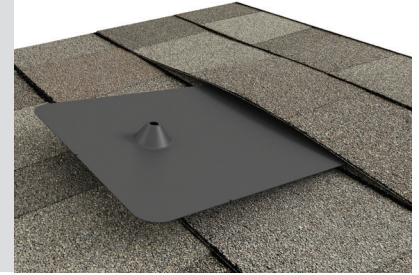

3

Place L-Foot over cone and install lag with washer through L-Foot.

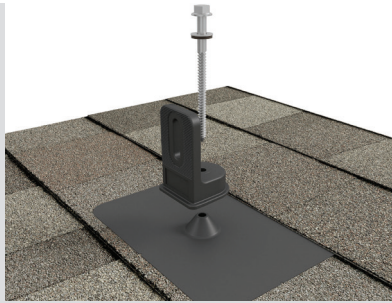

4

Drive lag to required depth. Attach rail per rail manufacturer's instructions.

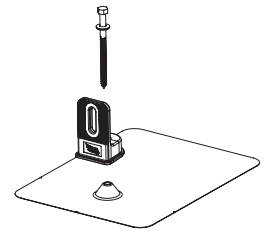
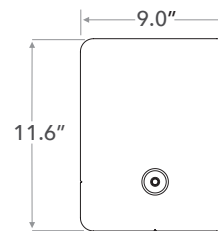
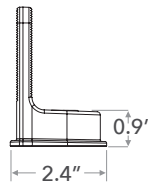
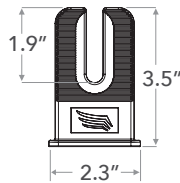
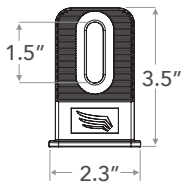
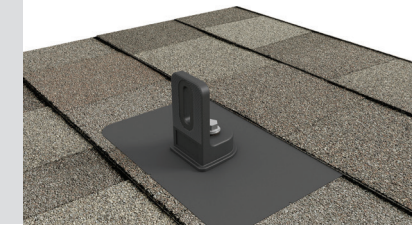

SPECIFICATIONS	COMP MOUNT INSTALL KITS				
SKU	PSCR-CBB0	PSCR-UBB0	SPCR-CBBH	PSCR-CMM0	PSCR-UMM0
Finish	Black L-Foot And Black Flashing			Mill	
L-Foot Type	Closed Slot	Open Slot	Closed Slot	Closed Slot	Open Slot
Kit Contents	L-Foot, Flashing, 5/16" x 4 1/2" SS Lag with metalized EPDM washer	L-Foot, Flashing, 5/16" x 4 1/2" SS Lag with metalized EPDM washer and M10 Hex Bolt	L-Foot, Flashing, 5/16" x 4 1/2" SS Lag with metalized EPDM washer	L-Foot, Flashing, 5/16" x 4 1/2" SS Lag with metalized EPDM washer	L-Foot, Flashing, 5/16" x 4 1/2" SS Lag with metalized EPDM washer
Roof Type	Composition Shingle				
Certifications	IBC, ASCE/SEI 7-16, AC286				
Install Application	Railed Systems				
Compatible Rail	Most				
Kit Quantity	24				
Boxes per Pallet	72				

Protected under US Patent: 10,998,847. Additional patents pending. All rights reserved. ©2021 Pegasus

SolaDeck

PV ROOF-MOUNT ENCLOSURE

**INTRODUCED AT
*SOLAR POWER 2007***



UL50 Type 3R Enclosure • Stamped 18 gauge gal. steel • Powder coated finish • Weather tight



Enclosure Includes:

- Dual ground lug
- Universal DIN rail
- 1/2", 3/4" & 1" knockouts
- Wire strain relief clip
- Complete hardware package

PV Roof-Mount Combiner/Enclosure

Benefits

- The ability to prep the building is now possible
- Replaces several parts used today
- Provides professional looking install
- Saves time on install
- Allows for easy access
- Guaranteed seal to roof
- Low profile design

***For product information contact us at
(866) 367-7782***

www.commdeck.com



RSTC Enterprises, Inc
2219 Heimstead Road
Eau Claire, WI 54703
1 (866) 367 - 7782



SolaDeck Part # 780

Specifications:

18 Gauge Steel Base (1) and Cover (2)
Pre Punched 7 holes in base (1) for roof deck
Pre Punched 4 holes in base (1) and cover (2) for match
Draw Process both parts
Powder Coated to withstand 1000 hours Salt Spray (Primer Gray)
High UV resistance
15" x 15" flashing dimension
Cavity dimension 8"W x 9" L x 2.5"D
Approx. 162 Cubic inch equipment cavity
Norloked steel base plate (3) to drawn base (2)
Three knockout locations .5", .75" and 1"
3" DIN rail installed
Grounding Lug- Installed (In Equipment Cavity)
Wire Strain Relief Clip –Installed (In Equipment Cavity)
Hardware pack withstands 500 hours Salt Spray
7 - 2" Trusshead Screws
4 - .5" 8-32 thread cutting screws
4 - #10 Bonded Seal washers
1 – Foam closed Cell Seal
ETL Listed UL50 Type 3R

Total Weight 6.9 pounds each

Packaging:

Individually bagged and boxed
Box dimension 15.5"w x 16" L x 3" D
White Carton labeled with Cut out template
Print One Color - Black

Master Cartons of 6 Units each
Master Carton dimension 18.75"x16"x16.375"
Master Carton Weight – 42 pounds
18 Master Cartons per skid Approx 800 pounds with skid



Product availability: Stock - Normally stocked in distribution facility



Main

Product or component type	Miniature circuit-breaker
Range of product	QOU
Circuit breaker type	Standard
Circuit breaker application	HACR and Switching Duty rated

Complementary

Line Rated Current	60 A
Number of Poles	2P
Interrupt Rating	10 KA 120/240 V AC 10 KA 120 V AC 5 kA 48 V DC
Electrical connection	Slotted box lugs, line side Slotted box lugs, load side
[Ue] rated operational voltage	120/240 V AC 120 V AC 48 V DC
Mounting mode	Unit mount
AWG gauge	AWG 14...AWG 2 aluminium/copper
Height	102.87 mm (4.05 in)
Depth	74.93 mm (2.95 in)
Width	38.10 mm (1.5 in)
Tightening torque	5.08 N.m (45 lbf.in) AWG 14...AWG 2)

Environment

Product certifications	UL listed CSA IEC
------------------------	-------------------------

Ordering and shipping details

Category	00900 - QOU BREAKERS & SWITCH
Discount Schedule	DE2
GTIN	00785901418801
Package weight(Lbs)	0.36 kg (0.8 lb(US))
Returnability	Yes
Country of origin	MX

Offer Sustainability

Sustainable offer status	Green Premium product
REACH Regulation	REACH Declaration
EU RoHS Directive	Compliant EU RoHS Declaration
Mercury free	Yes
RoHS exemption information	Yes
China RoHS Regulation	China RoHS Declaration
Environmental Disclosure	Product Environmental Profile
Circularity Profile	No need of specific recycling operations
Halogen content performance	Halogen free product

Contractual warranty

Warranty	18 months
----------	-----------

Product data sheet

Specifications

SQUARE D

Green Premium™



Safety switch, general duty, non fusible, 60A, 2 poles, 10 hp, 240 VAC, NEMA 3R, bolt-on provision

DU222RB

Product availability : Stock - Normally stocked in distribution facility

Price* : 353.00 USD

Main

Product	Single Throw Safety Switch
Duty Rating	General duty
Device Application	Residential
Disconnect Type	Non-fusible disconnect switch
Factory Installed Neutral	None
Phase	3 phase
Number of Poles	2
Current Rating	60 A
Voltage Rating	240 V AC
Enclosure Rating NEMA	NEMA 3R
Maximum Horse Power Rating	10 hp 240 V at AC 60 Hz for 1 phase conforming to NEC 430.52

Complementary

Mounting Type	Surface
Electrical Connection	Lugs
Wiring configuration	2 wires
Wire Size	AWG 12...AWG 3 aluminium AWG 14...AWG 3 copper
Tightening torque	35 lbf.in (3.95 N.m) 0.00...0.01 in ² (2.08...5.26 mm ²) (AWG 14...AWG 10) 35 lbf.in (3.95 N.m) (AWG 14...AWG 10) 45 lbf.in (5.08 N.m) 0.01 in ² (8.37 mm ²) (AWG 8) 45 lbf.in (5.08 N.m) 0.02...0.03 in ² (12.3...21.12 mm ²) (AWG 6...AWG 4) 50 lbf.in (5.65 N.m) 0.04 in ² (26.67 mm ²) (AWG 3)
Depth	3.75 in (95.25 mm)
Width	7.75 in (196.85 mm)
Height	9.63 in (244.60 mm)
Net Weight	16.98 lb(US) (7.7 kg)

Environment

Certifications	UL listed file E2875
----------------	----------------------

* Price is "List Price" and may be subject to a trade discount – check with your local distributor or retailer for actual price.

Ordering and shipping details

Category	00106-D & DU SW,NEMA3R, 30-200A
Discount Schedule	DE1A
GTIN	785901491491
Nbr. of units in pkg.	1
Package weight(Lbs)	4.65 lb(US) (2.109 kg)
Returnability	Yes
Country of origin	MX

Packing Units

Unit Type of Package 1	PCE
Package 1 Height	5.30 in (13.462 cm)
Package 1 width	7.20 in (18.288 cm)
Package 1 Length	10.00 in (25.4 cm)
Unit Type of Package 2	PAL
Number of Units in Package 2	120
Package 2 Weight	610.00 lb(US) (276.691 kg)
Package 2 Height	36.50 in (92.71 cm)
Package 2 width	40.00 in (101.6 cm)
Package 2 Length	48.00 in (121.92 cm)
Unit Type of Package 3	CAR
Number of Units in Package 3	5
Package 3 Weight	24.60 lb(US) (11.158 kg)
Package 3 Height	10.70 in (27.178 cm)
Package 3 width	10.20 in (25.908 cm)
Package 3 Length	23.50 in (59.69 cm)

Offer Sustainability

Sustainable offer status	Green Premium product
California proposition 65	WARNING: This product can expose you to chemicals including: Lead and lead compounds, which is known to the State of California to cause cancer and birth defects or other reproductive harm. For more information go to www.P65Warnings.ca.gov
REACH Regulation	REACH Declaration
REACH free of SVHC	Yes
EU RoHS Directive	Compliant EU RoHS Declaration
Toxic heavy metal free	Yes
Mercury free	Yes
RoHS exemption information	Yes
China RoHS Regulation	China RoHS declaration Pro-active China RoHS declaration (out of China RoHS legal scope)
Environmental Disclosure	Product Environmental Profile
PVC free	Yes

Contractual warranty

Warranty

18 months

Dimensions

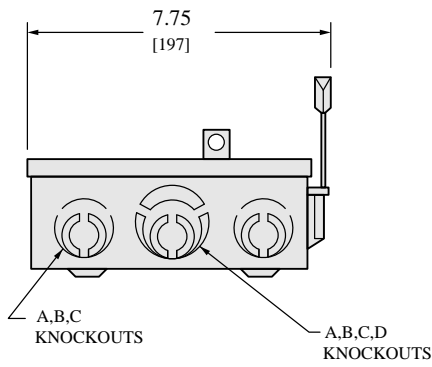
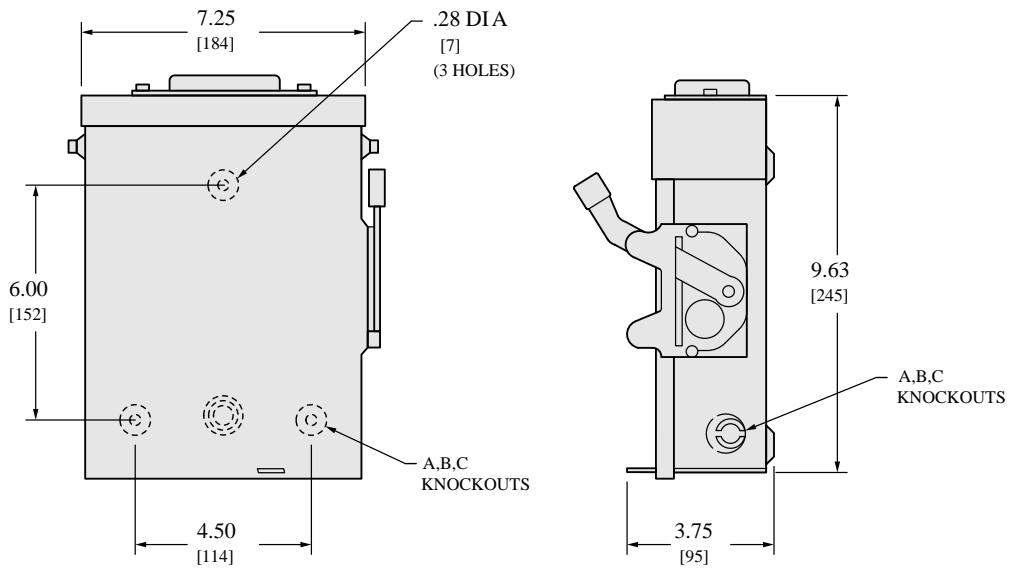

NEMA TYPE 3R

IN.
 [mm]

KNOCKOUTS				
SYMBOL	A	B	C	D
CONDUIT SIZE (IN.)	.50	.75	1	1.25

TOP OF NEMA TYPE 3R SWITCHES HAVE PROVISIONS FOR MAXIMUM 2 1/2" BO LT-ON HUB.
 ALL DIMENSIONS ARE APPROXIMATE. REFER TO TECHNICAL DRAWINGS AND DOCUMENTATION.

Wiring Diagram

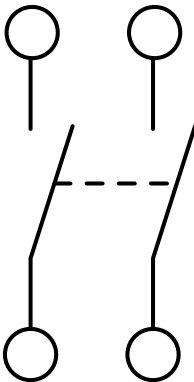

DU222RB