

Lucent Engineering, P.C.
814 E 1475 N
Lehi, UT 84043
m: (309) 645-0999
admin@lucenteng.co

November 3, 2022

Encōr Solar, LLC
3049 Executive Pkwy, Ste 300
Lehi, UT 84043

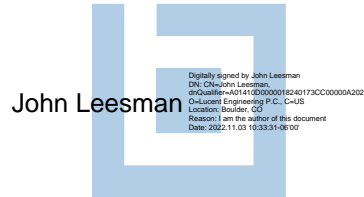

RE: Engineering Services
Apgood Residence
16 Great Oak Ct, Bunnlevel, NC
5 kW System
Solo Job #2915933

To Whom It May Concern,

We have reviewed the following information regarding the solar panel installation for this project. Alterations to these documents or plans shall not be made without direct written consent of the Engineer of Record.

A. Assumptions from Field Observation provided by Encōr Solar, LLC

The following structural design regarding the proposed alterations have been prepared from these assumptions. The verification of the field observations is the responsibility of the contractor. **Prior to commencement of work, the contractor shall verify the framing sizes, spacings, and spans noted in the sealed plans, calculations, and/or certification letter and notify the Engineer of Record of any discrepancies.**

	<u>Roof A</u>	<u>Roof B</u>
Roof Finish :	Asphalt Shingle	Asphalt Shingle
Roof Underlayment :	OSB	OSB
Roof Profile :	Gable	Gable
Roof Structural System :	Metal Plate Trusses	Metal Plate Trusses
Truss Top Chord/Setup :	2 x 4 / Fink	2 x 4 / Fink
Chord/Rafter Wood Grade :	Southern Pine #2 or better	Southern Pine #2 or better
Truss/Rafter Spacing :	24" o.c.	24" o.c.
Roof Slope :	34 deg	40 deg
Max Top Chord/Rafter Span :	8.72 ft	6.84 ft
Bearing Wall Type :	Convl Lt-Frame Constr	CLFC
Foundation :	Permanent Concrete	Permanent Concrete
Stories :	Two	Single

B. Building Design Criteria

Code :	2018 NCRC (ASCE 7-10)	Risk Category :	II
Roof Live Load :	20 psf (0 psf at panels)	Occupancy Class :	R-3
Ground Snow Load :	10 psf	Roof Dead Load :	6.5 psf
Ult Wind Speed :	120 mph	PV Dead Load :	<u>3 psf</u>
Exposure Category :	C	Total Dead Load :	9.5 psf

C. Summary of Existing Structure Results

Roof A & B

After review of the field observations and based on our calculations and in accordance with the applicable building codes and current industry standards, the existing roof structure supporting the proposed alterations consisting of the solar array has been determined to be:

- Adequate to support the additional imposed loads. **No structural upgrades are required.**

D. Solar Panel Support Bracket Anchorage

- 1. Solar panels shall be designed, mounted, and installed in accordance with the most recent "SnapNrack Manual", which can be found on the SnapNrack website (<http://snapnrack.com/>).
- 2. Manufacturer's Panel Bracket Connection to Roof Chord/Rafter Member:

Fastener : (1) 5/16" Lag Screw per Bracket
 NDS Withdrawl Value : 307 lbs/inch
 Min. Thread Length and Penetration Depth : 2.5"

- 3. Considering the existing roof's slope, size, spacing, condition, and calculated loads, the panel bracket supports shall be placed no greater than 48 in. o/c.
- 4. Panel supports connections shall be staggered to distribute load to adjacent trusses.

E. Overall Summary

Based on the information supplied to us at the time of this report, on the evaluation of the existing structure, and solar array panel bracket connection, it is our opinion that the roof system will adequately support the additional loads imposed by the solar array. This evaluation conforms to 2018 NCRC and current industry standards.

Should you have any questions regarding this letter or if you require further information, do not hesitate to contact me.

Sincerely,

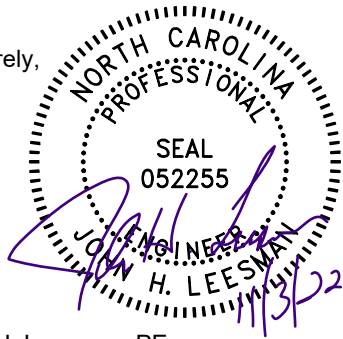

John H. Leesman, PE
License No. 52255

Limits of Scope of Work and Liability

The existing structure is assumed to have been designed and constructed following appropriate codes at the time of erection and assumed to have appropriated permits. The calculations performed are only for the roof framing supporting the solar array installation referenced in the stamped plans and were completed according to generally recognized structural analysis standards and procedures, professional engineering, and design experience opinions and judgements. Existing deficiencies which are unknown or were not observed during the time the site observation are not included in this scope of work. All solar panel modules, racking, and mounting equipment shall be designed and installed per the manufacturer's approved installation specifications. The Engineer of Record and the engineering consulting firm assume no responsibility for misuse or improper installation. This analysis is not stamped for water leakage. Framing was determined on information in provided plans and/or photos, along with engineering judgement. Prior to commencement of work, the contractor shall verify the framing sizes, spacings, and spans noted in the stamped plans, calculations, and/or certification letter and notify the Engineer of Record of any discrepancies prior to starting construction. If during solar panel installation, the roof framing members appear unstable or deflect non-uniformly, our office should be notified before proceeding with the installation. The contractor shall also verify that there are no damage/deficiencies (i.e., dry rot, water damage, termite damage, framing member/connection damage, etc.) to framing that was not addressed in the stamped plans, calculations, and/or certification letter and notify the Engineer of Record of any concerns prior to starting construction.

AERIAL VIEW:



STREET VIEW:



CONTRACTOR INFORMATION:
ENCOR SOLAR, LLC
3049 Executive Parkway
Suite 300
Lehi, UT 84043
License # 32830

SITE INFORMATION

Thomas Apgood
16 Great Oak Ct
Bunnlevel, NC 28323
AC System Size: 5 kW AC
DC System Size: 4.86 kW DC
Lat, 35.305295
Long, -78.9646844
(12) Jinko Solar JKM405M-72HL-V
PV Modules
(1) SolarEdge SE5000H-US (240V) Inverter(s)

(12) SolarEdge S440 Optimizers

South River EMC

SHEET INDEX:

- PV01 COVER PAGE
- PV02 SITE PLAN
- PV03 ROOF ATTACHMENTS
- PV04 MOUNTING DETAIL
- PV05 LINE DIAGRAM
- PV06 ELECTRICAL CALCS
- PV07 LABELS
- PV08 PLACARD
- PV09 SITE PHOTOS

DRAWN BY: SoloCAD

DATE:
November 2, 2022

COVER PAGE - PV01

GENERAL NOTES

1. INSTALLATION OF SOLAR PHOTOVOLTAIC SYSTEM SHALL BE IN ACCORDANCE WITH NEC ARTICLE 690, AND ALL OTHER APPLICABLE NEC CODES WHERE NOTED OR EXISTING
2. PROPER ACCESS AND WORKING CLEARANCE AROUND EXISTING AND PROPOSED ELECTRICAL EQUIPMENT WILL COMPLY WITH NEC ARTICLE 110
3. ALL WIRES, INCLUDING THE GROUNDING ELECTRODE CONDUCTOR SHALL BE PROTECTED FROM PHYSICAL DAMAGE IN ACCORDANCE WITH NEC ARTICLE 250
4. THE PV MODULES ARE CONSIDERED NON-COMBUSTIBLE; THIS SYSTEM IS UTILITY INTERACTIVE PER UL 1741 AND DOES NOT INCLUDE STORAGE BATTERIES OR OTHER ALTERNATIVE STORAGE SOURCES
5. ALL DC WIRES SHALL BE SIZED ACCORDING TO [NEC 690.8]
6. DC CONDUCTORS SHALL BE WITHIN PROTECTED RACEWAYS IN ACCORDANCE WITH [NEC 690.31]
7. ALL SIGNAGE TO BE PLACED IN ACCORDANCE WITH LOCAL JURISDICTIONAL BUILDING CODE

PHOTOVOLTAIC (PV) SYSTEM SPECIFICATIONS

AC System Size: 5 kW AC
DC System Size: 4.86 kW DC
(12) Jinko Solar JKM405M-72HL-V PV Modules
(1) SolarEdge SE5000H-US (240V) Inverter(s)
(12) SolarEdge S440 Optimizers
Racking: Speedseal Foot - 48" O.C.

APPLICABLE GOVERNING CODES

2020 NATIONAL ELECTRICAL CODE
2018 NORTH CAROLINA STATE BUILDING CODE: RESIDENTIAL
2018 NORTH CAROLINA STATE BUILDING CODE: BUILDING
2018 NORTH CAROLINA STATE BUILDING CODE: FIRE

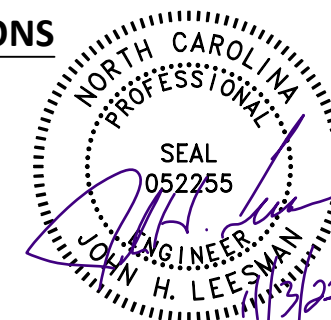

SITE SPECIFICATIONS

OCCUPANCY: R-3
ZONING: RESIDENTIAL



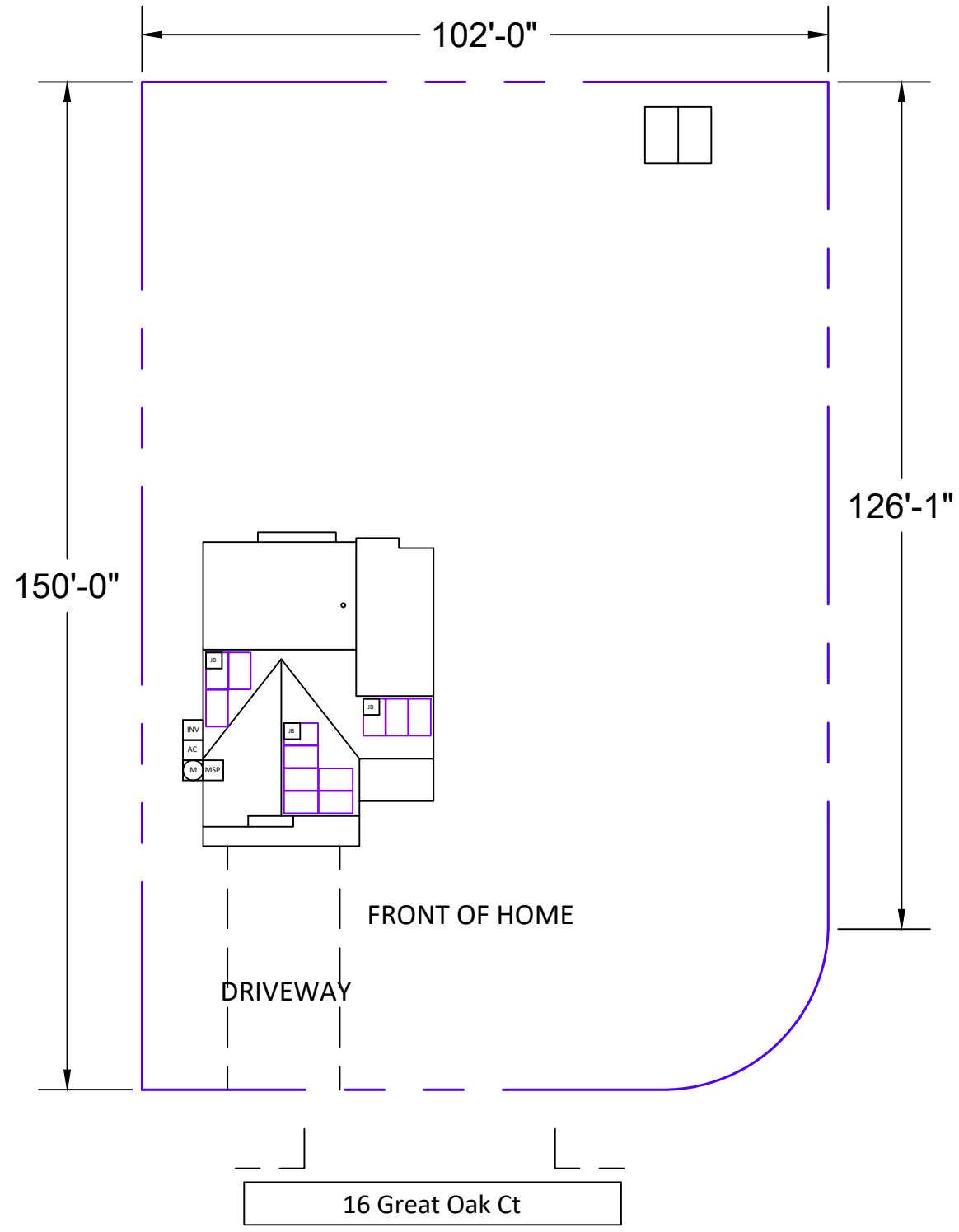
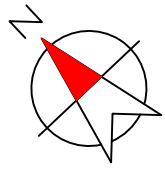

ARRAY DETAILS:		
MOUNTING PLANE:	AZIMUTH:	TILT:
MP1	133°	40°
MP2	223°	34°

CLOSE UP OF HOME

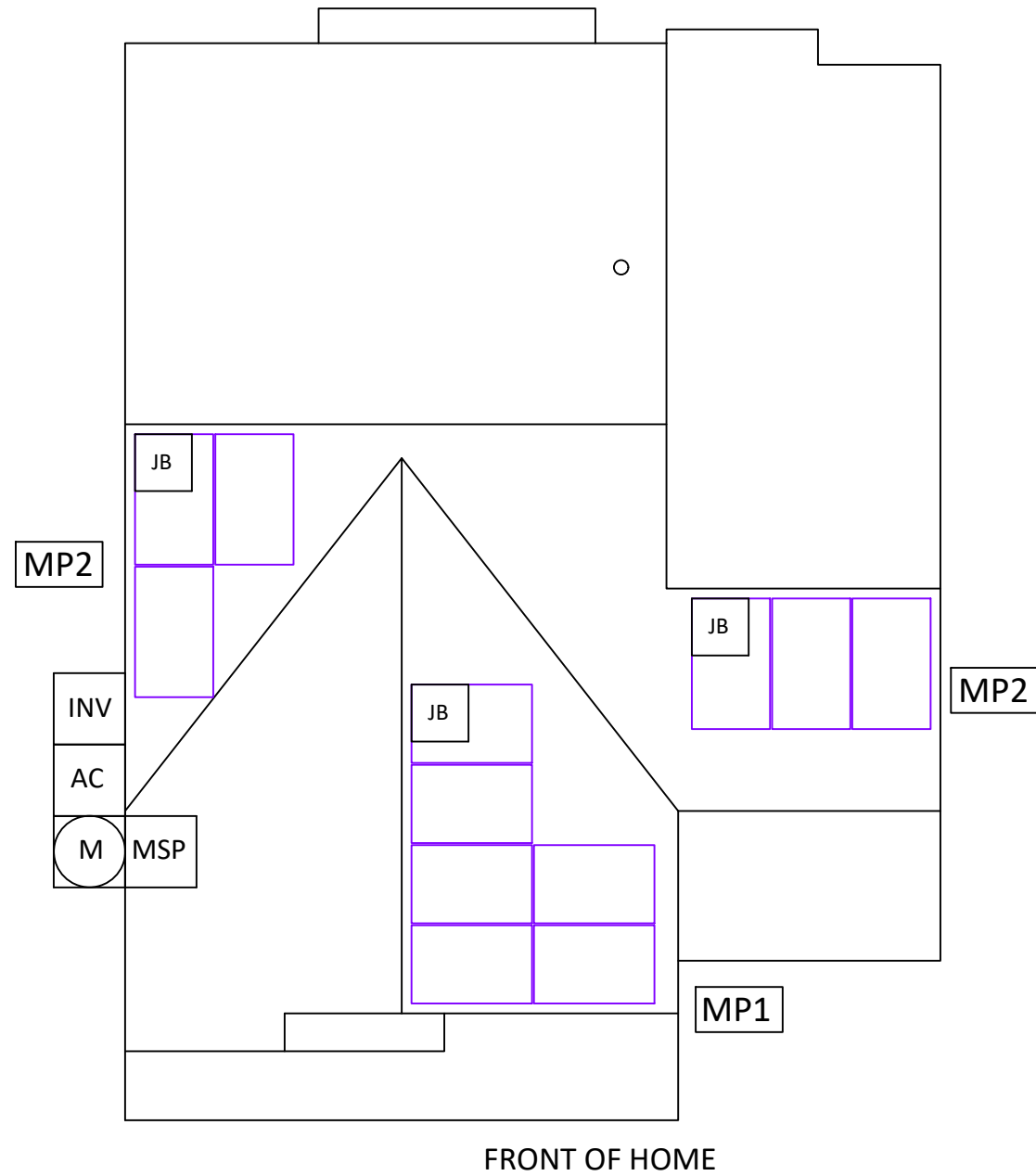

CONTRACTOR INFORMATION:
 ENCOR SOLAR, LLC
 3049 Executive Parkway
 Suite 300
 Lehi, UT 84043
 License # 32830

SITE INFORMATION

Thomas Apgood
 16 Great Oak Ct
 Bunnlevel, NC 28323
 AC System Size: 5 kW AC
 DC System Size: 4.86 kW DC
 Lat, 35.305295
 Long, -78.9646844
 (12) Jinko Solar JKM405M-72HL-V
 PV Modules
 (1) SolarEdge SE5000H-US (240V) Inverter(s)
 (12) SolarEdge S440 Optimizers

South River EMC

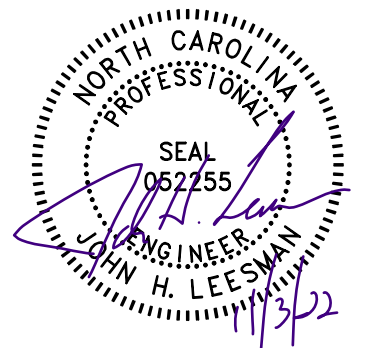

EQUIPMENT LEGEND:

- UTILITY METER
- VISIBLE, LOCKABLE, LABELED AC DISCONNECT
- INVERTER
- SUB PANEL
- SERVICE DISCONNECT
- PV MODULES
- FIRE ACCESS PATHWAY (3' TYP)
- MAIN SERVICE PANEL
- METER SOCKET (FOR UTILITY PV METER)
- COMBINER BOX
- LOAD CENTER
- BATTERY(IES)
- JUNCTION BOX
- PROPERTY LINE

VISIBLE, LOCKABLE, LABELED AC DISCONNECT LOCATED WITHIN 10' OF UTILITY METER

DRAWN BY: SoloCAD
 DATE:
 November 2, 2022
 SITE PLAN - PV02

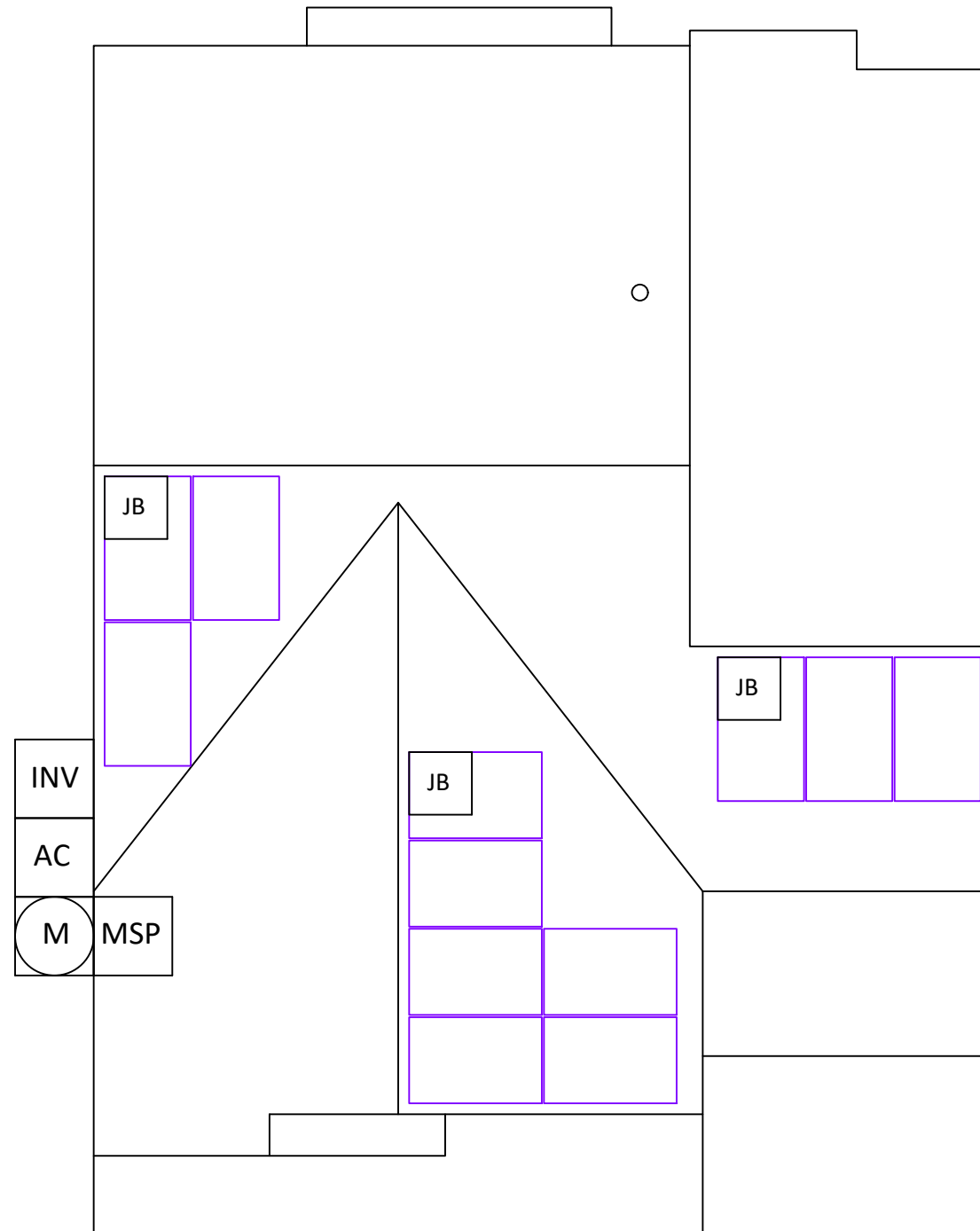
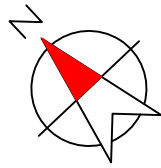

CONTRACTOR INFORMATION:
 ENCOR SOLAR, LLC
 3049 Executive Parkway
 Suite 300
 Lehi, UT 84043
 License # 32830

SITE INFORMATION

Thomas Apgood
 16 Great Oak Ct
 Bunnlevel, NC 28323
 AC System Size: 5 kW AC
 DC System Size: 4.86 kW DC
 Lat, 35.305295
 Long, -78.9646844
 (12) Jinko Solar JKM405M-72HL-V
 PV Modules
 (1) SolarEdge SE5000H-US (240V) Inverter(s)
 (12) SolarEdge S440 Optimizers

South River EMC

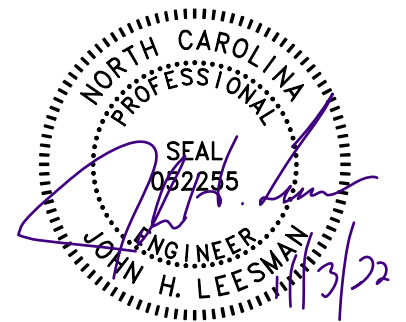

DRAWN BY: SoloCAD

DATE:
 November 2, 2022

ROOF ATTACHMENTS - PV03

EQUIPMENT INFORMATION:		ROOF INFO:		PHOTOVOLTAIC ARRAY STRUCTURAL CRITERIA:	
RAIL MANUFACTURER:	SnapNrack	ROOF TYPE:	Asphalt Shingle	PV MODULE COUNT:	12
RAIL PART NUMBER:	Ultra Rail UR-40	ROOF FRAMING:	Manufactured Truss	ARRAY AREA:	MODULE COUNT * 21.66 ft ² = 259.92
ATTACHMENTS	Speedseal Foot	RAFTER/TOP CHORD SIZE:	2x4	ROOF AREA:	1492 ft ²
ATTACHMENT QTY:	26	RAFTER/TOP CHORD SPACING:	24"	PERCENT OF ROOF COVERED:	17%
SPLICE QTY:	0	ATTACHMENT SPACING:	48"	ARRAY WEIGHT:	MODULE COUNT * 50 lbs = 600 lbs
MIDCLAMP QTY:	14			POINT LOAD:	ARRAY LBS/ATTACHMENTS = 23.08
ENDCLAMP QTY:	20			DISTRIBUTED LOAD: (lbs/ft ²)	(ARRAY) WEIGHT/AREA = 2.31 lbs/ft ²

SNAPNRACK UR SPEEDSEAL FOOT FOR COMPOSITION ROOF MOUNTING

MODULE HEIGHT OFF ROOF, RANGE:

UR-40: 3 3/8" - 4 3/8"
UR-60: 4" - 5"

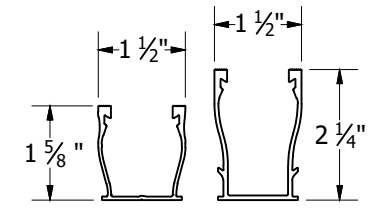
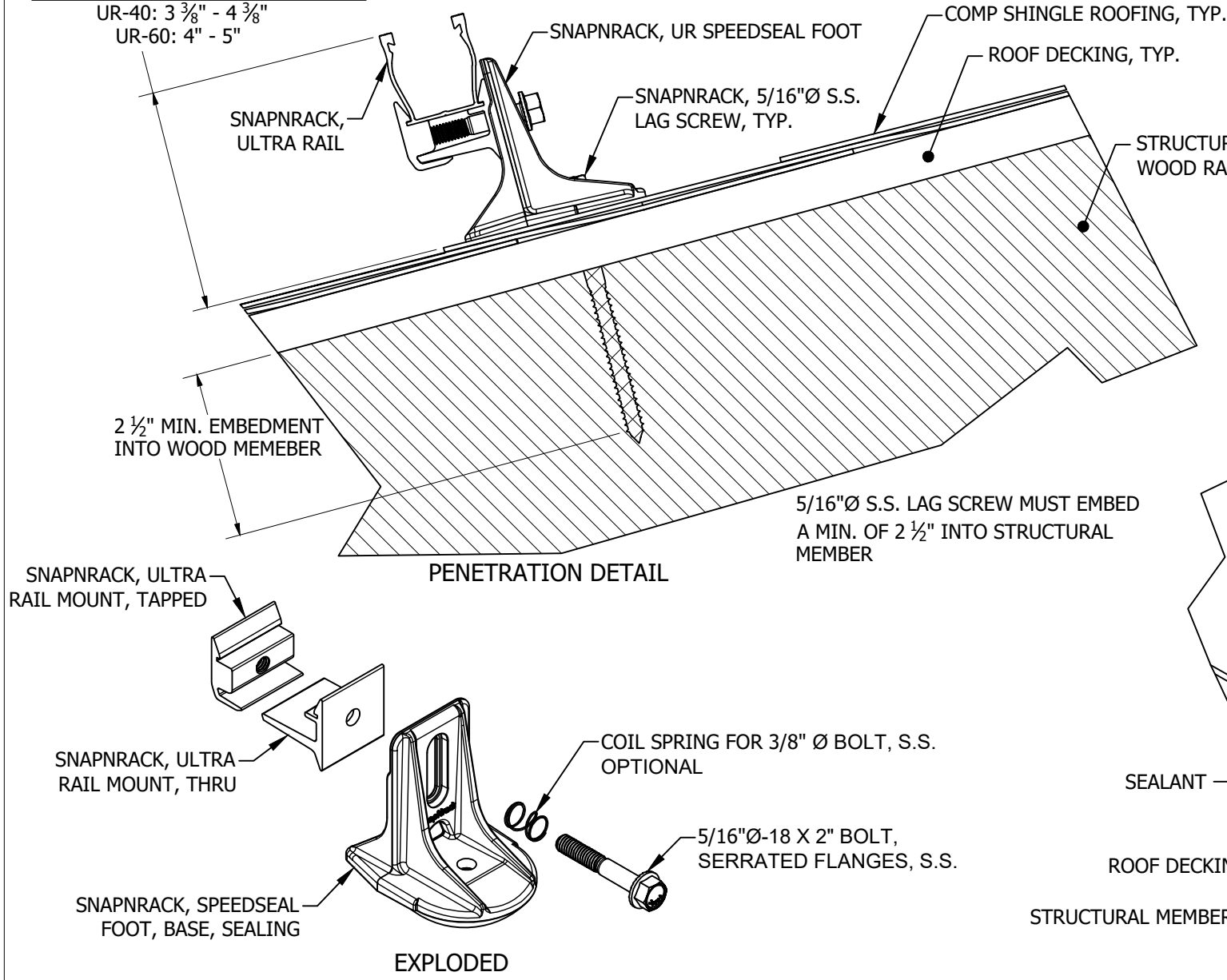

UR-40 RAIL | UR-60 RAIL
FOR USE WITH SNAPNRACK ULTRA SERIES RAILS

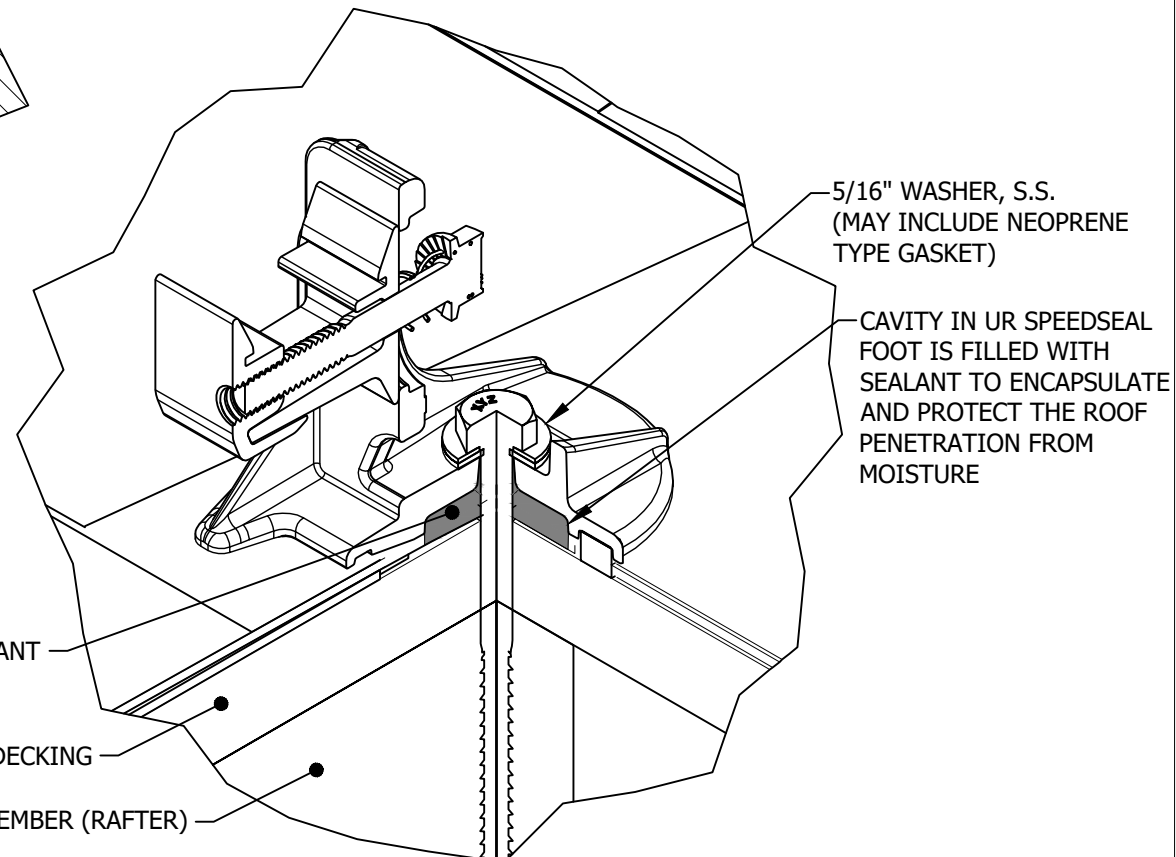

CONTRACTOR INFORMATION:
ENCOR SOLAR, LLC
3049 Executive Parkway
Suite 300
Lehi, UT 84043
License # 32830

SITE INFORMATION

Thomas Apgood
16 Great Oak Ct
Bunnlevel, NC 28323
AC System Size: 5 kW AC
DC System Size: 4.86 kW DC
Lat, 35.305295
Long, -78.9646844
(12) Jinko Solar JKM405M-72HL-V PV Modules
(1) SolarEdge SE5000H-US (240V) Inverter(s)
(12) SolarEdge S440 Optimizers

South River EMC



DRAWN BY: SoloCAD

DATE:
November 2, 2022

MOUNTING DETAIL - PV04

EQUIPMENT INFORMATION:		ROOF INFO:		PHOTOVOLTAIC ARRAY STRUCTURAL CRITERIA:	
RAIL MANUFACTURER:	SnapNrack	ROOF TYPE:	Asphalt Shingle	PV MODULE COUNT:	12
RAIL PART NUMBER:	Ultra Rail UR-40	ROOF FRAMING:	Manufactured Truss	ARRAY AREA:	MODULE COUNT * 21.66 ft ² = 259.92
ATTACHMENTS	Speedseal Foot	RAFTER/TOP CHORD SIZE:	2x4	ROOF AREA:	1492 ft ²
ATTACHMENT QTY:	26	RAFTER/TOP CHORD SPACING:	24"	PERCENT OF ROOF COVERED:	17%
SPLICE QTY:	0	ATTACHMENT SPACING:	48"	ARRAY WEIGHT:	MODULE COUNT * 50 lbs = 600 lbs
MIDCLAMP QTY:	14			POINT LOAD:	ARRAY LBS/ATTACHMENTS = 23.08
ENDCLAMP QTY:	20			DISTRIBUTED LOAD: (lbs/ft ²)	(ARRAY) WEIGHT/AREA = 2.31 lbs/ft ²

Jinko Solar JKM405M-72HL-V Specs	
POWER MAX (P _{MAX}):	405 W
OPEN CIRCUIT VOLTAGE (V _{OC}):	50.1 V
MAX POWER-POINT CURRENT (I _{MP}):	9.65 A
MAX POWER-POINT VOLTAGE (V _{MPP}):	42 V
SHORT CIRCUIT CURRENT (I _{SC}):	10.48 A
SERIES FUSE RATING:	20A

SolarEdge SE5000H-US (240V) Specs	
MAX INPUT VOLTAGE:	480 V
MAX INPUT CURRENT:	13.5 A
NOMINAL DC INPUT VOLTAGE:	380 V
MAXIMUM OUTPUT POWER:	5000 W
NOM. OUTPUT VOLTAGE:	240 V
MAX OUTPUT CURRENT:	21 A
1-Phase, 60 HZ, UL 1741 Listed	

Equipment Schedule				
TYPE:	QTY:	DESCRIPTION:	RATING:	
MODULES:	(12)	Jinko Solar JKM405M-72HL-V	405 W	
INVERTERS:	(1)	SolarEdge SE5000H-US (240V)	5000 W	
AC DISCONNECT(S):	(1)	PV AC Disconnect, 240V, 2-Pole	30 A	
DC OPTIMIZERS:	(12)	SolarEdge S440	15 Adc	

Conduit & Conductor Schedule				
TAG	QTY	WIRE GAUGE	DESCRIPTION	CONDUIT SIZE
1	(2)	10 AWG	PV-WIRE, USE-2 COPPER - (L1, L2)	N/A - FREE AIR
	(1)	6 AWG	BARE COPPER - (GROUND)	
2	(2)	10 AWG	THHN/THWN-2 COPPER - (L1, L2)	3/4" EMT
	(1)	10 AWG	THWN-2 COPPER - (GROUND)	
3	(2)	10 AWG	THHN/THWN-2 (L1, L2)	3/4" EMT
	(1)	10 AWG	THWN-2 COPPER -(GROUND)	
4	(3)	10 AWG	THWN-2 COPPER - (L1, L2, NEUTRAL)	3/4" EMT
	(1)	10 AWG	THWN-2 COPPER - (GROUND)	



CONTRACTOR INFORMATION:
ENCOR SOLAR, LLC
 3049 Executive Parkway
 Suite 300
 Lehi, UT 84043
 License # 32830

SITE INFORMATION

Thomas Apgood
 16 Great Oak Ct
 Bunnlevel, NC 28323
 AC System Size: 5 kW AC
 DC System Size: 4.86 kW DC
 Lat, 35.305295
 Long, -78.9646844
 (12) Jinko Solar JKM405M-72HL-V
 PV Modules
 (1) SolarEdge SE5000H-US (240V) Inverter(s)
 (12) SolarEdge S440 Optimizers

South River EMC

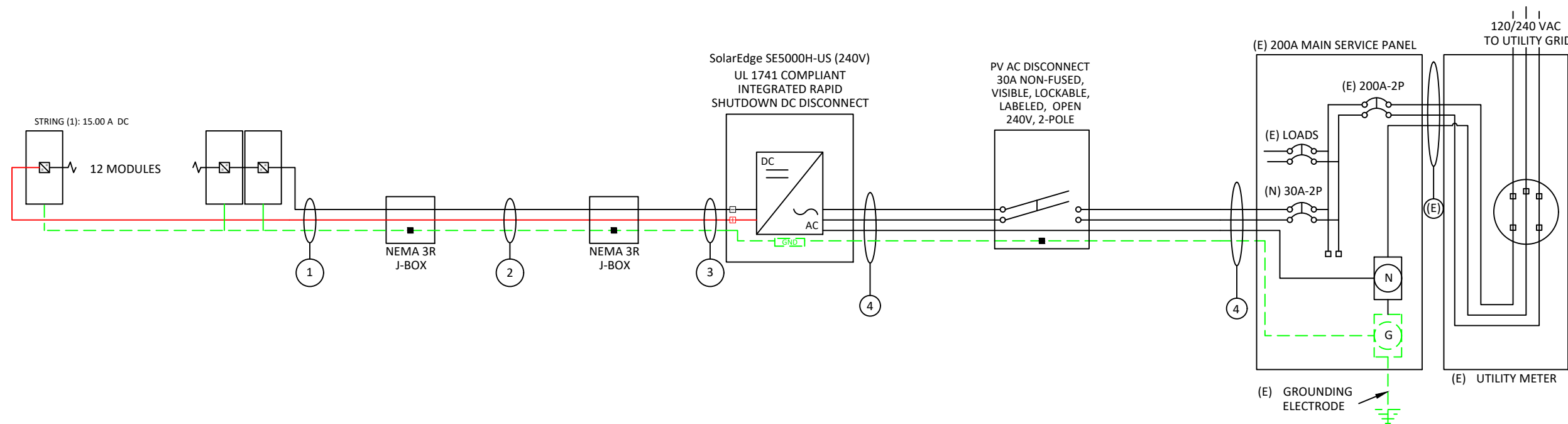

**VISIBLE, LOCKABLE,
 LABELED AC DISCONNECT
 LOCATED WITHIN 10'
 OF UTILITY METER**

DRAWN BY: SoloCAD
 DATE:
 November 2, 2022
LINE DIAGRAM - PV05

STRING CALCULATIONS	
SolarEdge SE5000H-US (240V)	STRING #1
OPTIMIZER MAX OUTPUT CURRENT:	15A
OPTIMIZERS IN SERIES:	12
NOMINAL STRING VOLTAGE:	380V
ARRAY OPERATING CURRENT:	13A
ARRAY DC POWER:	4860W
TOTAL MAX AC CURRENT:	21A

NUMBER OF CURRENT CARRYING CONDUCTORS	PERCENT OF VALUES
4-6	.80
7-9	.70
10-20	.50

SYSTEM OCPD CALCULATIONS	
INVERTER MODEL(S):	SolarEdge SE5000H-US (240V)
# OF INVERTERS:	1
MAX OUTPUT CURRENT:	21A
(# OF INVERTERS) X (MAX OUTPUT CURRENT) X 125% <= OCPD RATING	
(1 X 21A X 1.25) = 26.25A <= 30A, OK	

BUSBAR CALCULATIONS - 120% RULE	
MAIN BUSBAR RATING:	200A
MAIN DISCONNECT RATING:	200A
PV OCPD RATING:	30A
(MAIN BUS RATING X 120%) - MAIN DISCONNECT RATING >= OCPD RATING	
(200A X 1.2) - 200A = 40A, >= 30A, OK	

Conduit & Conductor Schedule											
TAG	QTY	WIRE GAUGE	DESCRIPTION	CONDUIT SIZE	CONDUCTOR RATING	CONDUCTOR TEMP. RATE	AMBIENT TEMP	TEMP. DERATE	# OF CONDUCTORS DERATE	CONDUCTOR RATING W/DERATES	CONDUIT FILL
1	(2)	10 AWG	PV-WIRE, USE-2 COPPER - (L1, L2)	N/A - FREE AIR	40A	90°C	36°C	0.91	N/A - FREE AIR	36.4A	N/A - FREE AIR
	(1)	6 AWG	BARE COPPER - (GROUND)								
2	(2)	10 AWG	THHN/THWN-2 COPPER - (L1, L2)	3/4" EMT	40A	90°C	36°C	0.91	1	36.4A	11.9%
	(1)	10 AWG	THWN-2 COPPER - (GROUND)								
3	(2)	10 AWG	THHN/THWN-2 (L1, L2)	3/4" EMT	40A	90°C	36°C	0.91	1	36.4A	11.9%
	(1)	10 AWG	THWN-2 COPPER - (GROUND)								
4	(3)	10 AWG	THWN-2 COPPER - (L1, L2, NEUTRAL)	3/4" EMT	35A	75°C	36°C	0.88	1	30.8A	15.9%
	(1)	10 AWG	THWN-2 COPPER - (GROUND)								



CONTRACTOR INFORMATION:
ENCOR SOLAR, LLC
 3049 Executive Parkway
 Suite 300
 Lehi, UT 84043
 License # 32830

SITE INFORMATION

Thomas Appood
 16 Great Oak Ct
 Bunnlevel, NC 28323
 AC System Size: 5 kW AC
 DC System Size: 4.86 kW DC
 Lat, 35.305295
 Long, -78.9646844
 (12) Jinko Solar JKM405M-72HL-V
 PV Modules
 (1) SolarEdge SE5000H-US (240V) Inverter(s)
 (12) SolarEdge S440 Optimizers

South River EMC

DRAWN BY: SoloCAD

DATE:
November 2, 2022

ELECTRICAL CALCS - PV06

GROUNDING & GENERAL NOTES:

- PV INVERTER IS UNGROUNDED, TRANSFORMER-LESS TYPE.
- DC GEC AND AC EGC TO BE SPICED TO EXISTING ELECTRODE
- ANY EXISTING WIRING INVOLVED WITH PV SYSTEM CONNECTION THAT IS FOUND TO BE INADEQUATE PER CODE SHALL BE CORRECTED PRIOR TO FINAL INSPECTION.
- JUNCTION BOX QUANTITIES, AND PLACEMENT SUBJECT TO CHANGE IN THE FIELD - JUNCTION BOXES DEPICTED ON ELECTRICAL DIAGRAM REPRESENT WIRE TYPE TRANSITIONS.
- AC DISCONNECT NOTED IN EQUIPMENT SCHEDULE OPTIONAL IF OTHER AC DISCONNECTING MEANS IS LOCATED WITHIN 10' OF SERVICE DISCONNECT.

INTERCONNECTION NOTES:

- INTERCONNECTION SIZING, LIMITATIONS AND COMPLIANCE DETERMINED IN ACCORDANCE WITH [NEC 705.12].
- GROUND FAULT PROTECTION IN ACCORDANCE WITH [NEC 215.9], [NEC 230.95] AND [NEC 690.41]
- ALL EQUIPMENT TO BE RATED FOR BACKFEEDING.
- PV BREAKER TO BE POSITIONED AT THE OPPOSITE END OF THE BUSBAR RELATIVE TO THE MAIN BREAKER.

DISCONNECT NOTES:

- DISCONNECTING SWITCHES SHALL BE WIRED SUCH THAT WHEN THE SWITCH IS OPENED THE CONDUCTORS REMAINING LIVE ARE CONNECTED TO THE TERMINALS MARKED "LINE SIDE" (TYPICALLY THE UPPER TERMINALS)
- AC DISCONNECT MUST BE ACCESSIBLE TO QUALIFIED UTILITY PERSONNEL, BE LOCKABLE, AND BE A VISIBLE-BREAK SWITCH

MAIN PHOTOVOLTAIC SYSTEM DISCONNECT

LABEL 1
PLACED ON THE MAIN DISCONNECTING MEANS FOR THE PV SYSTEM.
[NEC 690.13(B)]

WARNING
ELECTRIC SHOCK HAZARD
TERMINALS ON THE LINE AND
LOAD SIDES MAY BE ENERGIZED
IN THE OPEN POSITION

LABEL 2
FOR PV DISCONNECTING MEANS WHERE THE LINE AND
LOAD TERMINALS MAY BE ENERGIZED IN THE OPEN
POSITION.
[NEC 690.13(B)]

WARNING
POWER SOURCE OUTPUT CONNECTION.
DO NOT RELOCATE THIS OVERCURRENT DEVICE.

LABEL 3
PLACED ADJACENT TO THE BACK-FED BREAKER FROM
THE INVERTER IF TIE IN CONSISTS OF LOAD SIDE
CONNECTION TO BUSBAR.
[NEC 705.12(B)(3)(2)]

CAUTION
MULTIPLE SOURCES OF POWER

LABEL 4
PLACED ON EQUIPMENT CONTAINING OVERCURRENT
DEVICES IN CIRCUITS SUPPLYING POWER TO
A BUSBAR OR CONDUCTOR SUPPLIED FROM MULTIPLE
SOURCES
[NEC 705.10]

WARNING
THIS EQUIPMENT IS FED BY MULTIPLE
SOURCES. TOTAL RATING OF ALL
OVERCURRENT DEVICES, EXCLUDING
MAIN SUPPLY OVERCURRENT
DEVICE, SHALL NOT EXCEED
AMPACITY OF BUSBAR.

LABEL 5
EQUIPMENT CONTAINING OVERCURRENT
DEVICES IN CIRCUITS SUPPLYING POWER TO A
BUSBAR OR CONDUCTOR SUPPLIED FROM
MULTIPLE SOURCES SHALL BE MARKED TO
INDICATE THE PRESENCE OF ALL SOURCES.[NEC
705.12(B)(3)(3)]

PHOTOVOLTAIC AC DISCONNECT

RATED AC OUTPUT CURRENT: 21
NOMINAL OPERATING AC VOLTAGE: 240

LABEL 6
MARKED AT AC DISCONNECTING MEANS.
[NEC 690.54]

PHOTOVOLTAIC POWER SOURCE

SOLAR PV SYSTEM EQUIPPED WITH RAPID SHUTDOWN

TURN RAPID SHUTDOWN
SWITCH TO THE "OFF"
POSITION TO SHUT DOWN
PV SYSTEM AND REDUCE
SHOCK HAZARD IN ARRAY

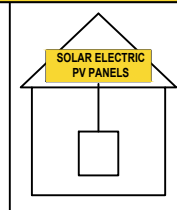

LABEL 7
AT DIRECT-CURRENT EXPOSED RACEWAYS, CABLE TRAYS, COVERS AND
ENCLOSURES OF JUNCTION BOXES, AND OTHER WIRING METHODS; SPACED
AT MAXIMUM 10FT SECTION OR WHERE SEPARATED BY ENCLOSURES, WALLS,
PARTITIONS, CEILINGS, OR FLOORS.
[NEC 690.31(D)(2)]

LABEL 8
FOR PV SYSTEMS THAT SHUT DOWN THE ARRAY AND CONDUCTORS
LEAVING THE ARRAY:
SIGN TO BE LOCATED ON OR NO MORE THAN 3 FT AWAY FROM
SERVICE DISCONNECTING MEANS TO WHICH THE PV SYSTEMS ARE
CONNECTED AND SHALL INDICATE THE LOCATION OF ALL IDENTIFIED
RAPID SHUTDOWN SWITCHES IF NOT AT THE SAME LOCATION.
[NEC 690.56(C)(1)]

RAPID SHUTDOWN SWITCH FOR SOLAR PV SYSTEM

LABEL 9
SIGN LOCATED ON OR NO MORE THAN 3FT
FROM INITIATION DEVICE
[NEC 690.56(C)(2)].



CONTRACTOR INFORMATION:
ENCOR SOLAR, LLC
3049 Executive Parkway
Suite 300
Lehi, UT 84043
License # 32830

SITE INFORMATION

Thomas Apgood
16 Great Oak Ct
Bunnlevel, NC 28323
AC System Size: 5 kW AC
DC System Size: 4.86 kW DC
Lat, 35.305295
Long, -78.9646844
(12) Jinko Solar JKM405M-72HL-V
PV Modules
(1) SolarEdge SE5000H-US (240V) Inverter(s)
(12) SolarEdge S440 Optimizers

South River EMC

LABELING NOTES:

1. LABELS CALLED OUT ACCORDING TO ALL COMMON CONFIGURATIONS. ELECTRICIAN TO DETERMINE EXACT REQUIREMENTS IN THE FIELD PER CURRENT NEC AND LOCAL CODES AND MAKE APPROPRIATE ADJUSTMENTS.
2. LABELING REQUIREMENTS BASED ON THE 2020 NATIONAL ELECTRIC CODE, OSHA STANDARD 19010.145, ANSI Z535.
3. MATERIAL BASED ON THE REQUIREMENTS OF THE AUTHORITY HAVING JURISDICTION.
4. LABELS TO BE OF SUFFICIENT DURABILITY TO WITHSTAND THE ENVIRONMENT INVOLVED [NEC 110.21]
5. LABELS TO BE A MINIMUM LETTER HEIGHT OF 3/8", WHITE ON RED BACKGROUND; REFLECTIVE, AND PERMANENTLY AFFIXED [NEC 690.31(D)(2)]

LABELING DIAGRAM:

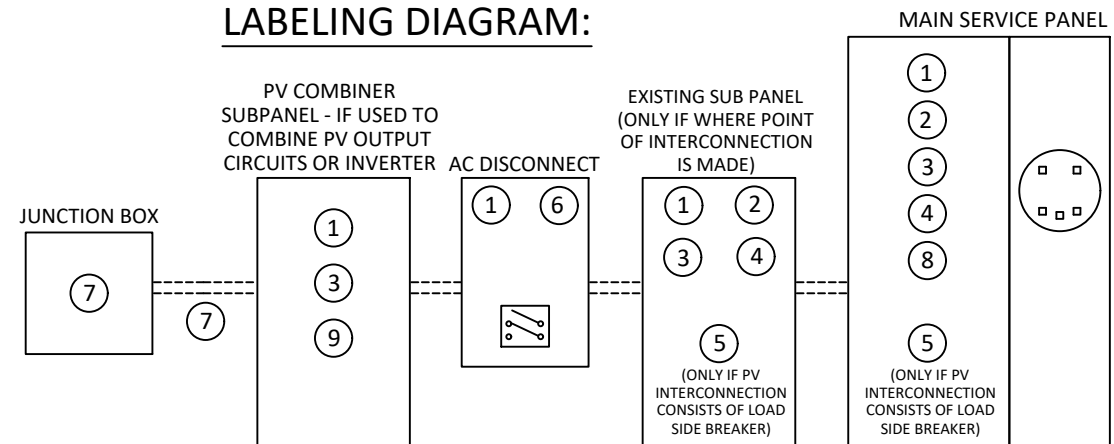

** ELECTRICAL DIAGRAM SHOWN ABOVE IS FOR LABELING PURPOSES ONLY. NOT AN ACTUAL REPRESENTATION OF EQUIPMENT AND CONNECTIONS TO BE INSTALLED. LABEL LOCATIONS PRESENTED MAY VARY DEPENDING ON TYPE OF INTERCONNECTION METHOD AND LOCATION PRESENTED ELECTRICAL DIAGRAM PAGE. **

DRAWN BY: SoloCAD

DATE:
November 2, 2022

LABELS - PV07

CAUTION

POWER TO THIS BUILDING IS ALSO SUPPLIED FROM ROOF MOUNTED SOLAR ARRAYS WITH SAFETY DISCONNECTS AS SHOWN:

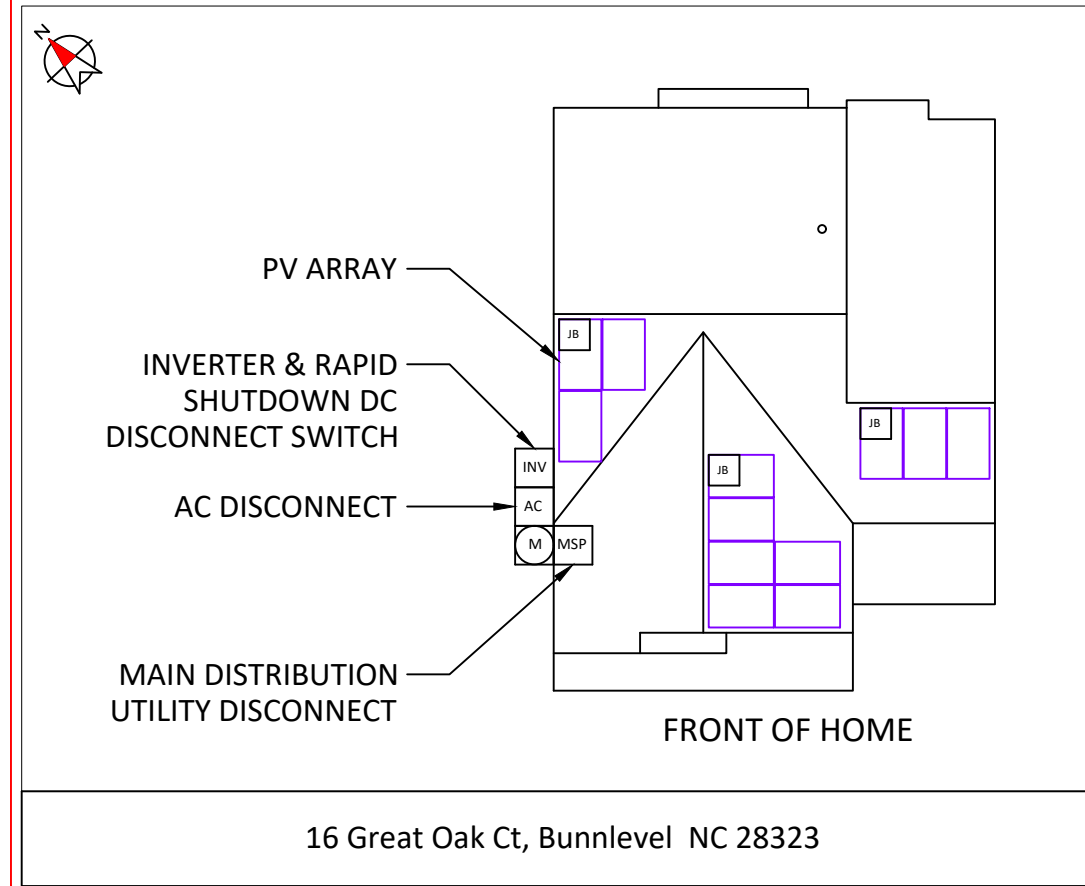

DIRECTORY

PERMANENT PLAQUE OR DIRECTORY PROVIDING THE LOCATION OF THE SERVICE DISCONNECTING MEANS AND THE PHOTOVOLTAIC SYSTEM.

(ALL PLAQUES AND SIGNAGE WILL BE INSTALLED AS OUTLINED WITHIN:
NEC 690.56(B)&(C), [NEC 705.10])



CONTRACTOR INFORMATION:

ENCOR SOLAR, LLC
3049 Executive Parkway
Suite 300
Lehi, UT 84043
License # 32830

SITE INFORMATION

Thomas Apgood

16 Great Oak Ct

Bunnlevel, NC 28323

AC System Size: 5 kW AC

DC System Size: 4.86 kW DC

Lat, 35.305295

Long, -78.9646844

(12) Jinko Solar JKM405M-72HL-V
PV Modules

(1) SolarEdge SE5000H-US (240V) Inverter(s)

(12) SolarEdge S440 Optimizers

South River EMC

DRAWN BY: SoloCAD

DATE:
November 2, 2022

PLACARD - PV08

SITE PHOTOS:



CONTRACTOR INFORMATION:
ENCOR SOLAR, LLC
 3049 Executive Parkway
 Suite 300
 Lehi, UT 84043
 License # 32830

SITE INFORMATION

Thomas Apgood
 16 Great Oak Ct
 Bunnlevel, NC 28323
 AC System Size: 5 kW AC
 DC System Size: 4.86 kW DC
 Lat, 35.305295
 Long, -78.9646844
 (12) Jinko Solar JKM405M-72HL-V
 PV Modules
 (1) SolarEdge SE5000H-US (240V) Inverter(s)
 (12) SolarEdge S440 Optimizers

South River EMC

DRAWN BY: SoloCAD

DATE:
 November 2, 2022

SITE PHOTOS - PV09

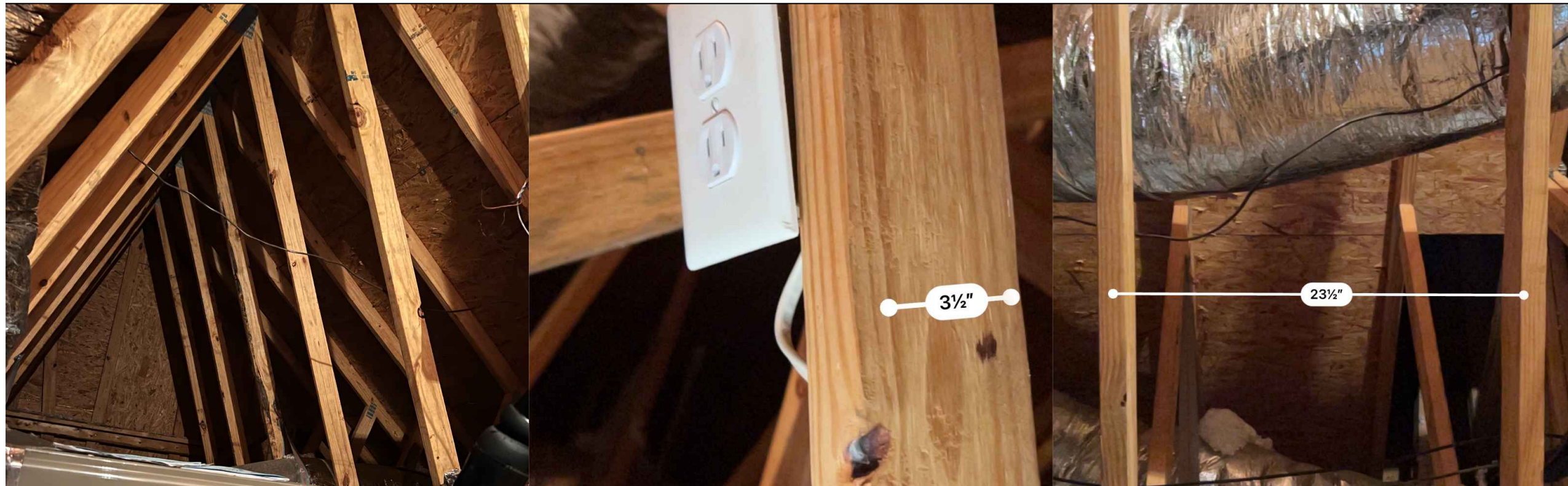

Eagle 72HM G2

390-410 Watt

MONO PERC HALF CELL MODULE

Positive power tolerance of 0~+3%

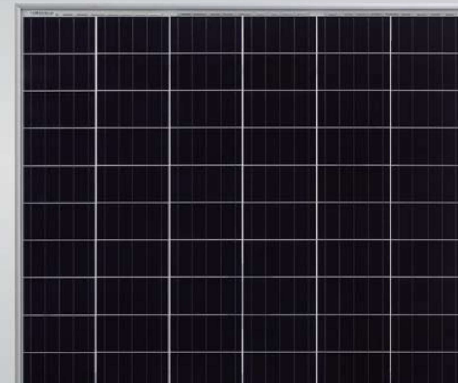

KEY FEATURES

- Diamond Cell Technology**
Uniquely designed high performance 5 busbar mono PERC half cell
- 1500V High Voltage**
UL and IEC 1500V certified; lowers BOS costs and yields better LCOE
- Higher Module Power**
Decrease in current loss yields higher module efficiency
- Shade Tolerance**
More shade tolerance due to twin arrays
- PID FREE**
Reinforced cell prevents potential induced degradation
- Strength and Durability**
Certified for high snow (5400Pa) and wind (2400 Pa) loads

LINEAR PERFORMANCE WARRANTY

12 Year Product Warranty • 25 Year Linear Power Warranty

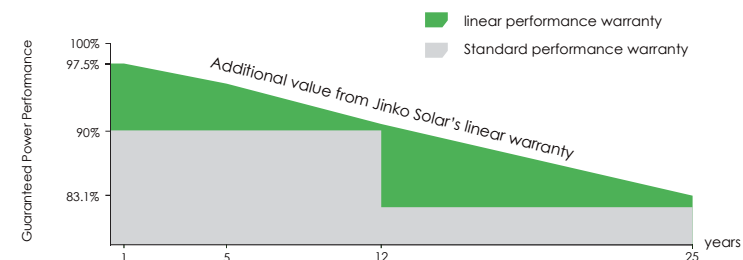

- ISO9001:2008 Quality Standards
- ISO14001:2004 Environmental Standards
- OHSAS18001 Occupational Health & Safety Standards
- IEC61215, IEC61730 certified products
- UL1703 certified products

Nomenclature:

JKM410M-72HL-V

Code	Cell	Code	Cell	Code	Certification
null	Full	null	Normal	null	1000V
H	Half	L	Diamond	V	1500V



Engineering Drawings

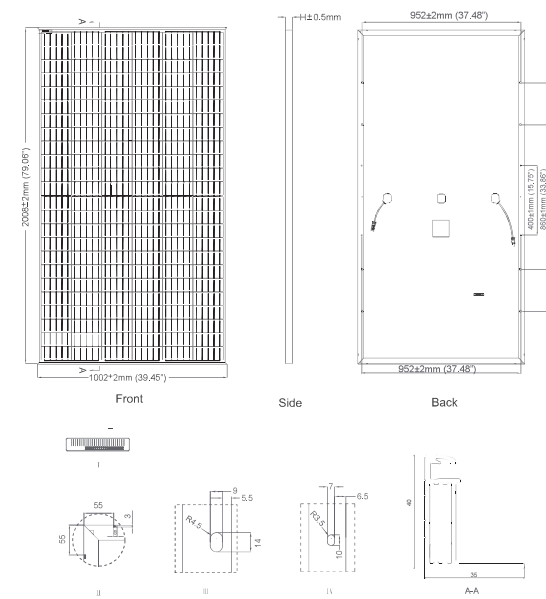

Packaging Configuration

(Two pallets = One stack)
27pcs/pallet, 54pcs/stack, 594pcs/40' HQ Container

Electrical Performance & Temperature Dependence

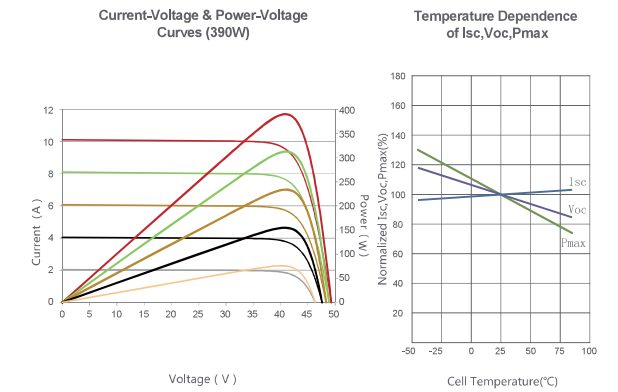

Mechanical Characteristics

Cell Type	Mono PERC Diamond Cell (158.75 x 158.75 mm)
No. of Half-cells	144 (6x24)
Dimensions	2008x1002x40mm (79.06x39.45x1.57 inch)
Weight	22.5 kg (49.6 lbs)
Front Glass	3.2mm, Anti-Reflection Coating, High Transmission, Low Iron, Tempered Glass
Frame	Anodized Aluminium Alloy
Junction Box	IP67 Rated
Output Cables	12 AWG, (+) 1400mm(55.12 in), (-) 1400mm(55.12 in) or Customized Length
Fire Type	Type 1

SPECIFICATIONS

Module Type	JKM390M-72HL-V		JKM395M-72HL-V		JKM400M-72HL-V		JKM405M-72HL-V		JKM410M-72HL-V	
	STC	NOCT	STC	NOCT	STC	NOCT	STC	NOCT	STC	NOCT
Maximum Power (Pmax)	390Wp	294Wp	395Wp	298Wp	400Wp	302Wp	405Wp	306Wp	410Wp	310Wp
Maximum Power Voltage (Vmp)	41.1V	39.1V	41.4V	39.3V	41.7V	39.6V	42.0V	39.8V	42.3V	40.0V
Maximum Power Current (Imp)	9.49A	7.54A	9.55A	7.60A	9.60A	7.66A	9.65A	7.72A	9.69A	7.76A
Open-circuit Voltage (Voc)	49.3V	48.0V	49.5V	48.2V	49.8V	48.5V	50.1V	48.7V	50.4V	48.9V
Short-circuit Current (Isc)	10.12A	8.02A	10.23A	8.09A	10.36A	8.16A	10.48A	8.22A	10.60A	8.26A
Module Efficiency STC (%)	19.38%		19.63%		19.88%		20.13%		20.38%	
Operating Temperature (°C)	-40°C~+85°C									
Maximum System Voltage	1500VDC(UL)/1500VDC(IEC)									
Maximum Series Fuse Rating	20A									
Power Tolerance	0~+3%									
Temperature Coefficients of Pmax	-0.36%/°C									
Temperature Coefficients of Voc	-0.28%/°C									
Temperature Coefficients of Isc	0.048%/°C									
Nominal Operating Cell Temperature (NOCT)	45±2°C									

STC: ☀ Irradiance 1000W/m² 📱 Cell Temperature 25°C ☁ AM=1.5

NOCT: ☀ Irradiance 800W/m² 📱 Ambient Temperature 20°C ☁ AM=1.5 🌀 Wind Speed 1m/s

* Power measurement tolerance: ± 3%

CAUTION: READ SAFETY AND INSTALLATION INSTRUCTIONS BEFORE USING THE PRODUCT.
© Jinko Solar Co., Ltd. All rights reserved. Specifications included in this datasheet are subject to change without notice.
JKM390-410M-72HL-V-A2-US

Single Phase Inverter with HD-Wave Technology for North America

SE3000H-US / SE3800H-US / SE5000H-US / SE6000H-US / SE7600H-US / SE10000H-US / SE11400H-US

12-25
YEAR
WARRANTY



INVERTERS

Optimized installation with HD-Wave technology

- Specifically designed to work with power optimizers
- Record-breaking 99% weighted efficiency
- Quick and easy inverter commissioning directly from a smartphone using the SolarEdge SetApp
- Fixed voltage inverter for longer strings
- Integrated arc fault protection and rapid shutdown for NEC 2014, NEC 2017 and NEC 2020 per article 690.11 and 690.12
- UL1741 SA certified, for CPUC Rule 21 grid compliance
- Small, lightweight, and easy to install both outdoors or indoors
- Built-in module-level monitoring
- Optional: Faster installations with built-in consumption metering (1% accuracy) and production revenue grade metering (0.5% accuracy, ANSI C12.20)

solaredge.com



Single Phase Inverter with HD-Wave Technology for North America

SE3000H-US / SE3800H-US / SE5000H-US / SE6000H-US / SE7600H-US / SE10000H-US / SE11400H-US

MODEL NUMBER	SE3000H-US	SE3800H-US	SE5000H-US	SE6000H-US	SE7600H-US	SE10000H-US	SE11400H-US		
APPLICABLE TO INVERTERS WITH PART NUMBER	SEXXXXH-XXXXXBXX4								
OUTPUT									
Rated AC Power Output	3000	3800 @ 240V 3300 @ 208V	5000	6000 @ 240V 5000 @ 208V	7600	10000	11400 @ 240V 10000 @ 208V	VA	
Maximum AC Power Output	3000	3800 @ 240V 3300 @ 208V	5000	6000 @ 240V 5000 @ 208V	7600	10000	11400 @ 240V 10000 @ 208V	VA	
AC Output Voltage Min.-Nom.-Max. (211 - 240 - 264)	✓	✓	✓	✓	✓	✓	✓	Vac	
AC Output Voltage Min.-Nom.-Max. (183 - 208 - 229)	-	✓	-	✓	-	-	✓	Vac	
AC Frequency (Nominal)	59.3 - 60 - 60.5 ⁽¹⁾							Hz	
Maximum Continuous Output Current @240V	12.5	16	21	25	32	42	47.5	A	
Maximum Continuous Output Current @208V	-	16	-	24	-	-	48.5	A	
Power Factor	1, Adjustable - 0.85 to 0.85								
GFDI Threshold	1							A	
Utility Monitoring, Islanding Protection, Country Configurable Thresholds	Yes								
INPUT									
Maximum DC Power @240V	4650	5900	7750	9300	11800	15500	17650	W	
Maximum DC Power @208V	-	5100	-	7750	-	-	15500	W	
Transformer-less, Ungrounded	Yes								
Maximum Input Voltage				480				Vdc	
Nominal DC Input Voltage	380			400				Vdc	
Maximum Input Current @240V ⁽²⁾	8.5	10.5	13.5	16.5	20	27	30.5	Adc	
Maximum Input Current @208V ⁽²⁾	-	9	-	13.5	-	-	27	Adc	
Max. Input Short Circuit Current	45							Adc	
Reverse-Polarity Protection	Yes								
Ground-Fault Isolation Detection	600ka Sensitivity								
Maximum Inverter Efficiency	99	99.2							%
CEC Weighted Efficiency	99						99 @ 240V 98.5 @ 208V	%	
Nighttime Power Consumption	< 2.5							W	

(1) For other regional settings please contact SolarEdge support

(2) A higher current source may be used; the inverter will limit its input current to the values stated

/ Single Phase Inverter with HD-Wave Technology for North America

SE3000H-US / SE3800H-US / SE5000H-US / SE6000H-US/
SE7600H-US / SE10000H-US / SE11400H-US

MODEL NUMBER	SE3000H-US	SE3800H-US	SE5000H-US	SE6000H-US	SE7600H-US	SE10000H-US	SE11400H-US
ADDITIONAL FEATURES							
Supported Communication Interfaces	RS485, Ethernet, ZigBee (optional), Cellular (optional)						
Revenue Grade Metering, ANSI C12.20	Optional ⁽³⁾						
Consumption metering							
Inverter Commissioning	With the SetApp mobile application using Built-in Wi-Fi Access Point for Local Connection						
Rapid Shutdown - NEC 2014, NEC 2017 and NEC 2020, 690.12	Automatic Rapid Shutdown upon AC Grid Disconnect						
STANDARD COMPLIANCE							
Safety	UL1741, UL1741 SA, UL1699B, CSA C22.2, Canadian AFCL according to T.I.L. M-07						
Grid Connection Standards	IEEE1547, Rule 21, Rule 14 (H)						
Emissions	FCC Part 15 Class B						
INSTALLATION SPECIFICATIONS							
AC Output Conduit Size / AWG Range	1" Maximum / 14-6 AWG			1" Maximum / 14-4 AWG			
DC Input Conduit Size / # of Strings / AWG Range	1" Maximum / 1-2 strings / 14-6 AWG			1" Maximum / 1-3 strings / 14-6 AWG			
Dimensions with Safety Switch (HxWxD)	17.7 x 14.6 x 6.8 / 450 x 370 x 174			21.3 x 14.6 x 7.3 / 540 x 370 x 185			
Weight with Safety Switch	22 / 10	25.1 / 11.4	26.2 / 11.9	38.8 / 17.6			
Noise	< 25			< 50			
Cooling	Natural Convection						
Operating Temperature Range	-40 to +140 / -40 to +60 ⁽⁴⁾						
Protection Rating	NEMA 4X (Inverter with Safety Switch)						

(3) Inverter with Revenue Grade Meter P/N: SExxxH-US000BNC4; Inverter with Revenue Grade Production and Consumption Meter P/N: SExxxH-US000BN4. For consumption metering, current transformers should be ordered separately: SEACT0750-200NA-20 or SEACT0750-400NA-20, 20 units per box

(4) Full power up to at least 50°C / 122°F; for power de-rating information refer to: <https://www.solaredge.com/sites/default/files/se-temperature-derating-note-na.pdf>

How to Enable Consumption Monitoring

By simply wiring current transformers through the inverter's existing AC conduits and connecting them to the service panel, homeowners will gain full insight into their household energy usage helping them to avoid high electricity bills

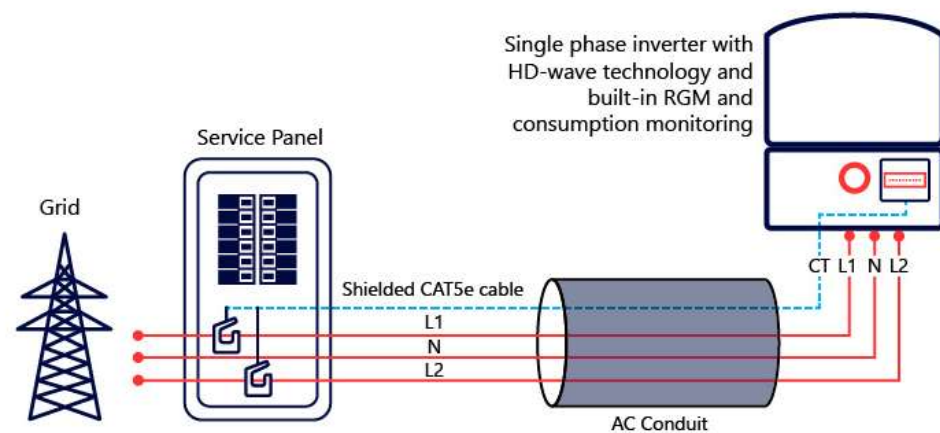

Power Optimizer For North America

S440, S500



POWER OPTIMIZER

PV power optimization at the module level

- Specifically designed to work with SolarEdge residential inverters
- Detects abnormal PV connector behavior, preventing potential safety issues*
- Module-level voltage shutdown for installer and firefighter safety
- Superior efficiency (99.5%)
- Mitigates all types of module mismatch loss, from manufacturing tolerance to partial shading
- Faster installations with simplified cable management and easy assembly using a single bolt
- Flexible system design for maximum space utilization
- Compatible with bifacial PV modules
- Meets NEC requirements for arc fault protection (AFCI) and Photovoltaic Rapid Shutdown System (PVRSS)

* Expected availability in 2022

solaredge.com



/ Power Optimizer For North America S440, S500

	S440	S500	Unit
INPUT			
Rated Input DC Power ⁽¹⁾	440	500	W
Absolute Maximum Input Voltage (Voc)	60		Vdc
MPPT Operating Range	8 - 60		Vdc
Maximum Short Circuit Current (Isc) of Connected PV Module	14.5	15	Adc
Maximum Efficiency	99.5		%
Weighted Efficiency	98.6		%
Overtoltage Category	II		
OUTPUT DURING OPERATION			
Maximum Output Current	15		Adc
Maximum Output Voltage	60		Vdc
OUTPUT DURING STANDBY (POWER OPTIMIZER DISCONNECTED FROM INVERTER OR INVERTER OFF)			
Safety Output Voltage per Power Optimizer	1 +/- 0.1		Vdc
STANDARD COMPLIANCE			
Photovoltaic Rapid Shutdown System	NEC 2014, 2017 & 2020		
EMC	FCC Part 15 Class B, IEC61000-6-2, IEC61000-6-3		
Safety	IEC62109-1 (class II safety), UL1741		
Material	UL94 V-0, UV Resistant		
RoHS	Yes		
Fire Safety	VDE-AR-E 2100-712:2013-05		
INSTALLATION SPECIFICATIONS			
Maximum Allowed System Voltage	1000		Vdc
Dimensions (W x L x H)	129 x 153 x 30 / 5.07 x 6.02 x 1.18		mm / in
Weight (including cables)	655 / 1.5		gr / lb
Input Connector	MC4 ⁽²⁾		
Input Wire Length	0.1 / 0.32		m / ft
Output Connector	MC4		
Output Wire Length	(+) 2.3, (-) 0.10 / (+) 7.54, (-) 0.32		m / ft
Operating Temperature Range ⁽³⁾	-40 to +85		°C
Protection Rating	IP68 / Type6B		
Relative Humidity	0 - 100		%

(1) Rated power of the module at STC will not exceed the power optimizer Rated Input DC Power. Modules with up to +5% power tolerance are allowed
 (2) For other connector types please contact SolarEdge
 (3) For ambient temperature above +70°C / +158°F power de-rating is applied. Refer to Power Optimizers Temperature De-Rating Technical Note for more details

PV System Design Using a SolarEdge Inverter	Single Phase HD-Wave	Three Phase for 208V grid	Three Phase for 277/480V grid	
Minimum String Length (Power Optimizers)	S440, S500	8	14	18
Maximum String Length (Power Optimizers)		25		50 ⁽⁴⁾
Maximum Nominal Power per String		5700 (6000 with SE7600-US-SE11400-U)	6000	12750
Maximum Allowed Connected Power per String ⁽⁵⁾ (Permitted only when the difference in connected power between strings is 1,000W or less)	Refer to Footnote 5	One String 7200W		15,000W
Parallel Strings of Different Lengths or Orientations		Y		

(4) A string with more than 30 optimizers does not meet NEC rapid shutdown requirements; safety voltage will be above the 30V requirement
 (5) If the inverters rated AC power < maximum nominal power per string, then the maximum power per string will be able to reach up to the inverters maximum input DC power. Refer to: <https://www.solaredge.com/sites/default/files/se-power-optimizer-single-string-design-application-note.pdf>
 (6) It is not allowed to mix S-series and P-series Power Optimizers in new installations

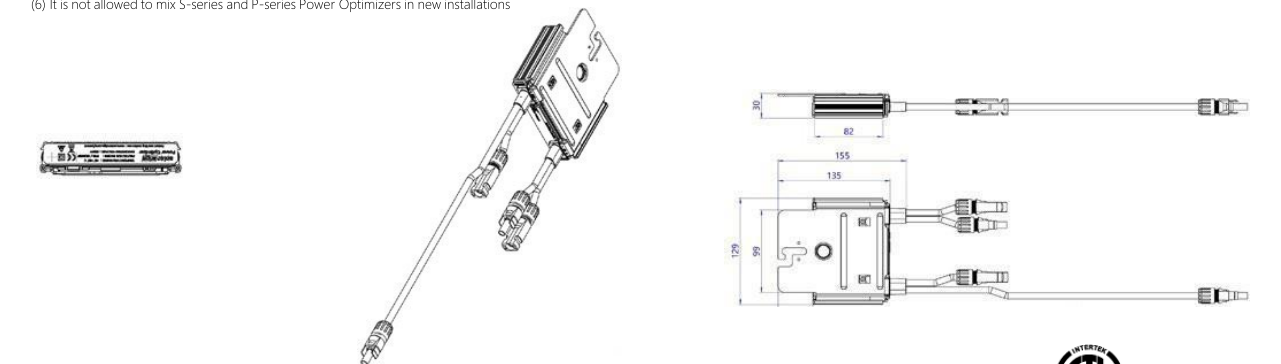

© SolarEdge Technologies, Inc. All rights reserved. SOLAREEDGE, the SolarEdge logo, OPTIMIZED BY SOLAREEDGE are trademarks or registered trademarks of SolarEdge Technologies, Inc. All other trademarks mentioned herein are trademarks of their respective owners. Date: February 8, 2022 DS-000018-NA. Subject to change without notice.



Ultra Rail

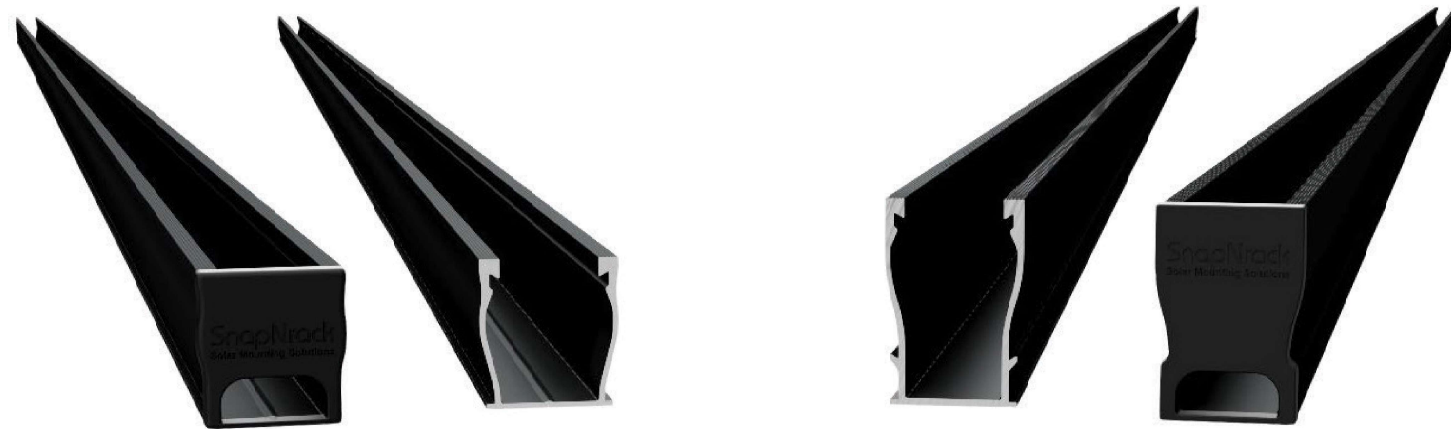

SnapNrack Ultra Rail System
A sleek, straightforward rail solution for mounting solar modules on all roof types. Ultra Rail features two rail profiles; UR-40 is a lightweight rail profile that is suitable for most geographic regions and maintains all the great features of SnapNrack rail, while UR-60 is a heavier duty rail profile that provides a larger rail channel and increased span capabilities. Both are compatible with all existing mounts, module clamps, and accessories for ease of install.

The Entire System is a Snap to Install

- New Ultra Rail Mounts include snap-in brackets for attaching rail
- Compatible with all the SnapNrack Mid Clamps and End Clamps customers love
- Universal End Clamps and snap-in End Caps provide a clean look to the array edge

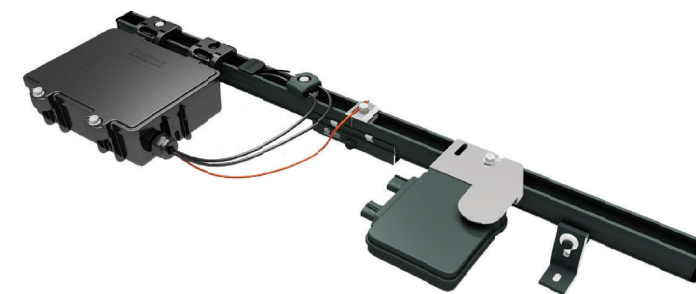

Unparalleled Wire Management

- Open rail channel provides room for running wires resulting in a long-lasting quality install
- Industry best wire management offering includes Junction Boxes, Universal Wire Clamps, MLPE Attachment Kits, and Conduit Clamps
- System is fully bonded and listed to UL 2703 Standard

The Ultimate Value in Rooftop Solar



Industry leading Wire Management Solutions



Mounts available for all roof types



Single Tool Installation



All SnapNrack Module Clamps & Accessories are compatible with both rail profiles

Heavy Duty UR-60 Rail

- UR-60 rail profile provides increased span capabilities for high wind speeds and snow loads
- Taller, stronger rail profile includes profile-specific rail splice and end cap
- All existing mounts, module clamps, and accessories are retained for the same great install experience



Start Installing Ultra Rail Today

RESOURCES
DESIGN
WHERE TO BUY

snapnrack.com/resources
snapnrack.com/configurator
snapnrack.com/where-to-buy

Quality. Innovative. Superior.

SnapNrack Solar Mounting Solutions are engineered to optimize material use and labor resources and improve overall installation quality and safety.

877-732-2860

www.snapnrack.com

contact@snapnrack.com

© 2019 by SnapNrack Solar Mounting Solutions. All rights reserved

DESCRIPTION: SNAPNRACK, ULTRA RAIL SPEEDSEAL™ FOOT	DRAWN BY: mwatkins	 595 MARKET STREET, 29TH FLOOR • SAN FRANCISCO, CA 94105 USA PHONE (415) 580-6900 • FAX (415) 580-6902 <small>THE INFORMATION IN THIS DRAWING IS CONFIDENTIAL AND PROPRIETARY. ANY REPRODUCTION, DISCLOSURE, OR USE THEREOF IS PROHIBITED WITHOUT THE WRITTEN CONSENT OF SUNRUN SOUTH LLC.</small>
PART NUMBER(S): 242-02163, 242-02167	REVISION: A	

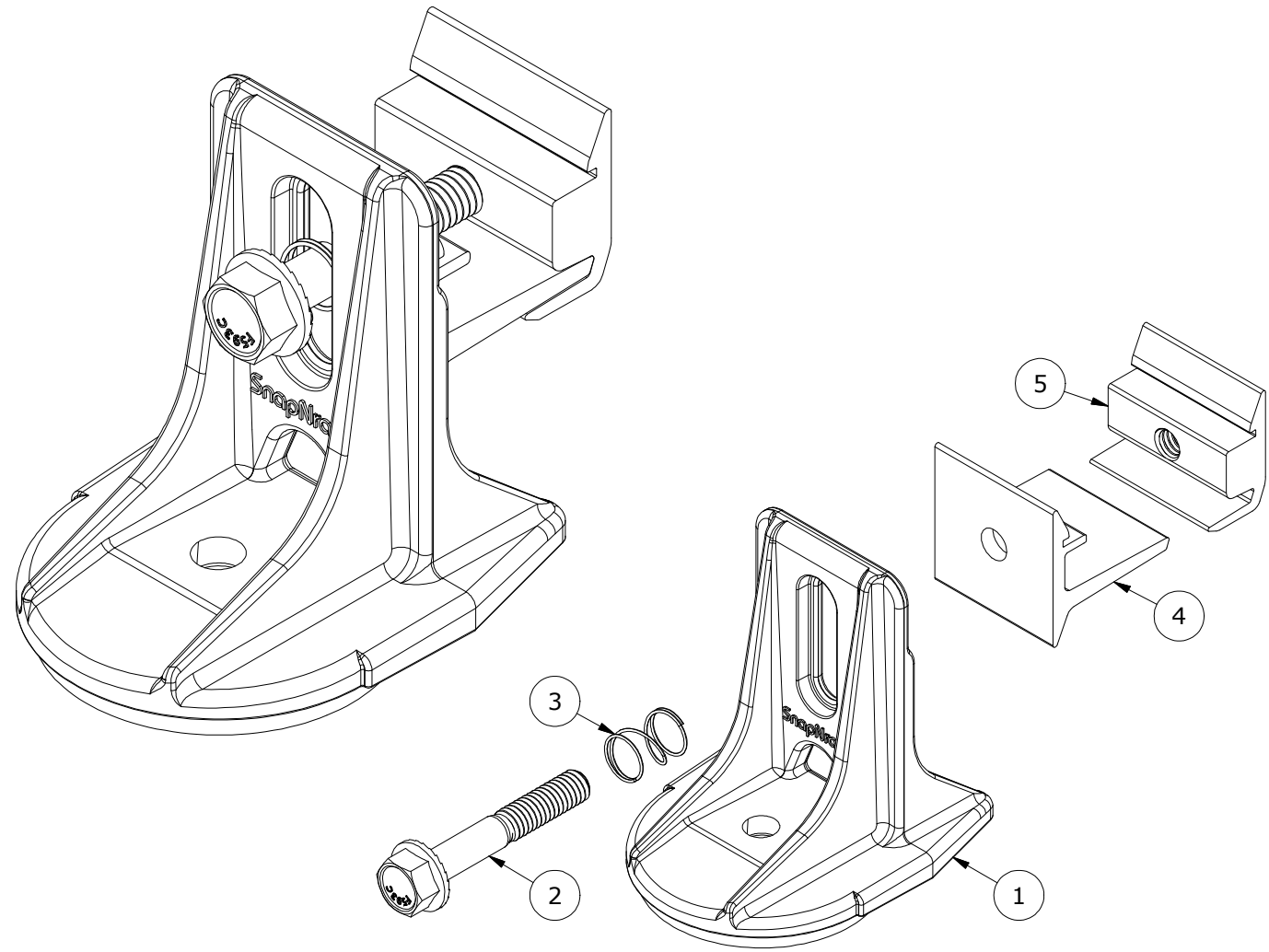

PARTS LIST		
ITEM	QTY	DESCRIPTION
1	1	SNAPNRACK, SPEEDSEAL FOOT, BASE, SEALING, SILVER / BLACK
2	1	BOLT, FLANGE, SERRATED, 5/16IN-18 X 2IN, SS
3	1	SNAPNRACK, RL UNIVERSAL, MOUNT SPRING, SS
4	1	SNAPNRACK, ULTRA RAIL MOUNT THRU PRC, CLEAR / BLACK
5	1	SNAPNRACK, ULTRA RAIL MOUNT TAPPED PRC, CLEAR / BLACK

MATERIALS:	DIE CAST A380 ALUMINUM, 6000 SERIES ALUMINUM, STAINLESS STEEL	
DESIGN LOAD (LBS):	802 UP, 1333 DOWN, 357 SIDE	OPTIONS:
ULTIMATE LOAD (LBS):	2118 UP, 4006 DOWN, 1331 SIDE	CLEAR / BLACK
TORQUE SPECIFICATION:	12 LB-FT	
CERTIFICATION:	UL 2703, FILE E359313; WIND-DRIVEN RAIN TEST FROM SUBJECT UL 2582	
WEIGHT (LBS):	0.45	

DESCRIPTION: SNAPNRACK, ULTRA RAIL SPEEDSEAL™ FOOT	DRAWN BY: mwatkins	 595 MARKET STREET, 29TH FLOOR • SAN FRANCISCO, CA 94105 USA PHONE (415) 580-6900 • FAX (415) 580-6902 <small>THE INFORMATION IN THIS DRAWING IS CONFIDENTIAL AND PROPRIETARY. ANY REPRODUCTION, DISCLOSURE, OR USE THEREOF IS PROHIBITED WITHOUT THE WRITTEN CONSENT OF SUNRUN SOUTH LLC.</small>
PART NUMBER(S): 242-02163, 242-02167	REVISION: A	

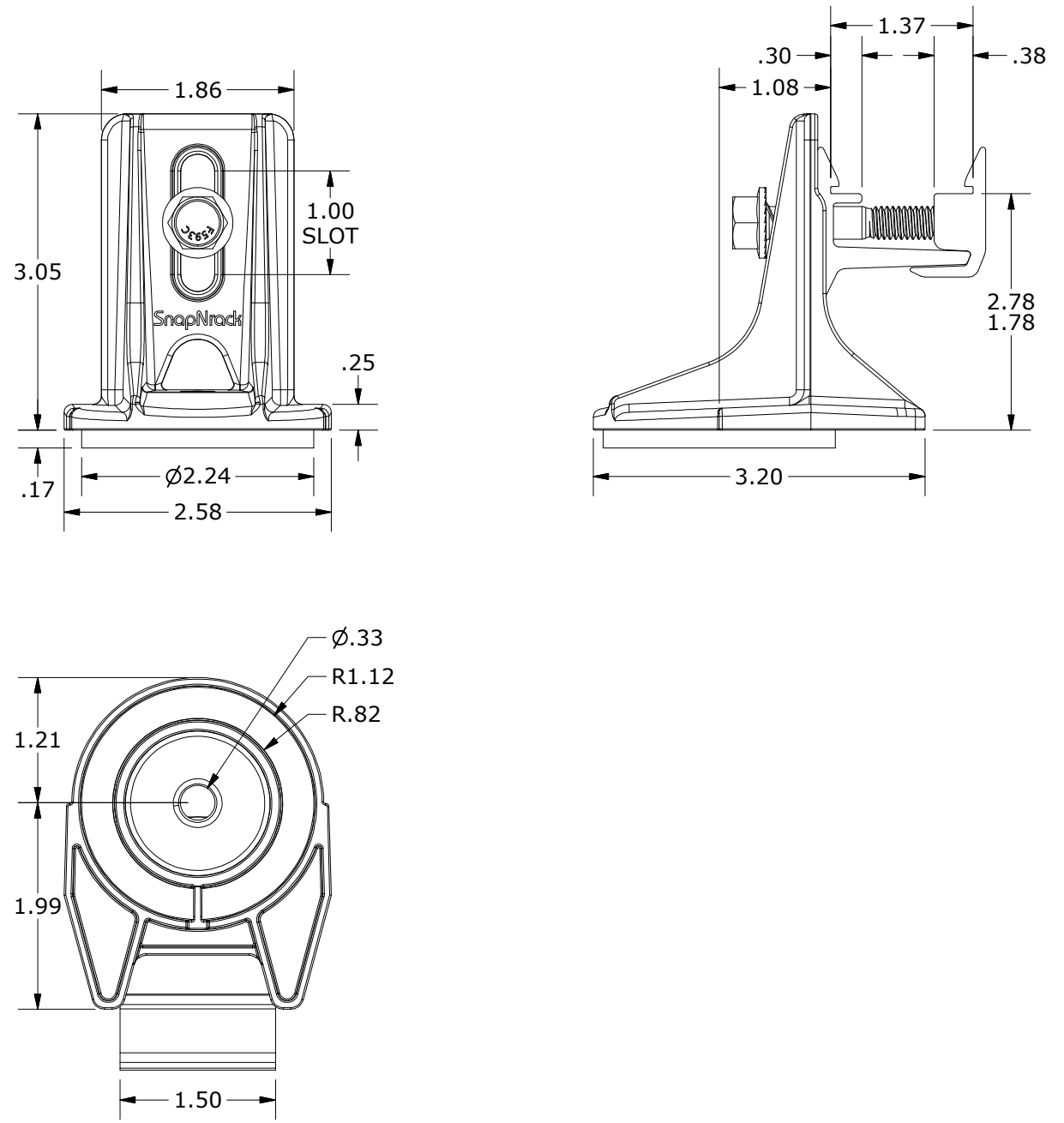

ALL DIMENSIONS IN INCHES

SnapNrack SpeedSeal™ Foot

Patent Pending Lag Driven Sealant Solution for Ultra Rail



A New Generation of Roof Attachments

- Innovative design incorporates flashing reliability into a single roof attachment
- 100% waterproof solution
- Sealing cavity with compressible barrier secures sealant in place & fills voids

Maintain the Integrity of the Roof by Eliminating Disruption

- Zero prying of shingles
- Zero removal of nails leaving holes in the roof
- Roof remains installed the way manufacturer meant it to be

Lag Driven Sealant Waterproofing

- Time Tested Roof Sealant provides lasting seal
- Sealant is compressed into cavity and lag hole as attachment is secured to rafter
- Active sealant solidifies bond if ever touched by liquid
- Technology passes UL 2582 Wind Driven Rain Test and ASTM E2140 Water Column Testing standards. Patent Pending.

Single Tool Installation

- SnapNrack was the first in the industry to develop a complete system that only requires a single tool. That tradition is continued as a ½” socket is still the only tool necessary to secure the mount as well as all other parts of the system.

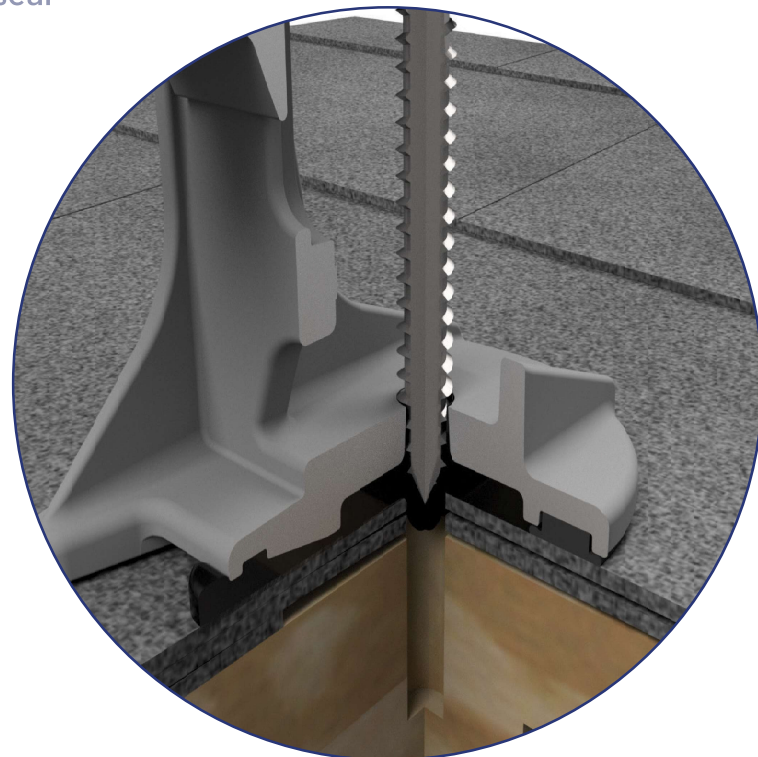

Note: Sealant shown in white for illustration purposes only.

SnapNrack SpeedSeal™ Foot

Fastest Roof Attachment in Solar

- Lag straight to a structural member, no in-between components such as flashings or bases.
- Simply locate rafter, fill sealant cavity & secure to roof. *It's that simple!*

Integrated Flashings. No Questions.

- Sealant fills around lag screw keeping roof and structure sealed and intact
- No added holes from ripping up nails, staples and screws holding shingles on roof

Less Time. Less Parts. Less Tools.

- No more need for a pry bar to rip up shingles
- No more proprietary lag screws
- Single Tool installation with ½” socket

Total System Solution One Tool. One Warranty.

- SnapNrack Ultra Rail is a straightforward intuitive install experience on the roof without compromising quality, aesthetics & safety, all supported by a 25 year warranty.
- Built-in Wire Management & Aesthetically pleasing features designed for Ultra Rail result in a long-lasting quality install that installers and homeowners love.

Certifications

SnapNrack Ultra Rail System has been evaluated by Underwriters Laboratories (UL) and Listed to UL/ANSI Standard 2703 for Mechanical Loading and Fire. Additionally it is listed to UL 2582 for wind-driven rain and ASTM 2140.

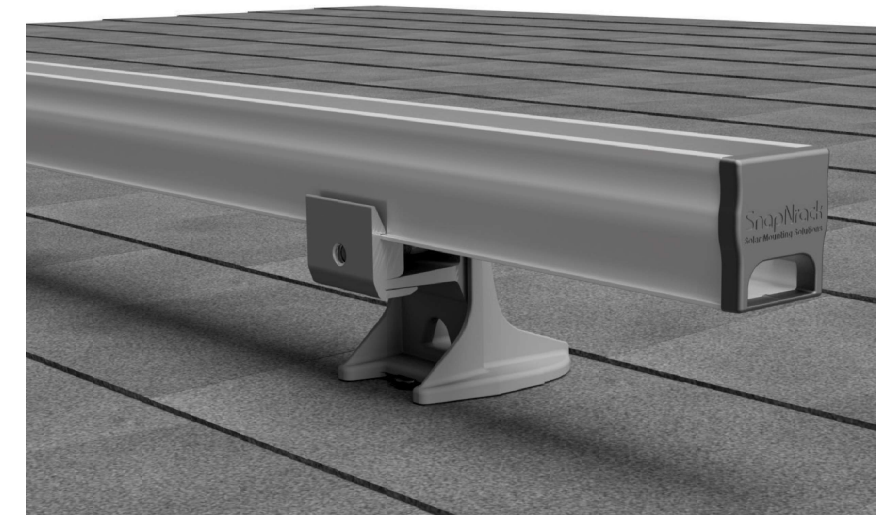

Bill Of Materials

Thomas Apgood		
16 Great Oak Ct, Bunnlevel, NC 28323		
Electrical Equipment		
QTY	Part #	Description
12	Jinko Solar JKM405M-72HL-V	Jinko Solar JKM405M-72HL-V Solar Modules
1	SolarEdge SE5000H-US (240V)	SolarEdge SE5000H-US (240V) Inverter(s)
12	SolarEdge S440	SolarEdge S440 Optimizers
1	SE-GSM-R05-US-S1	SolarEdge GSM w/ 5 Year Plan
1	30A AC Disconnect	AC Disconnect, NEMA 3R, 30A, 240VAC, 2-Pole
3	Junction Box	Junction Box
Breakers and Fuses		
1	30A 2-Pole Breaker(s)	General 30A 2-Pole Breaker(s)
Racking		
7	232-02537	SNAPNRACK, UR-40 RAIL, 172IN, SILVER
14	242-02070	SNAPNRACK, ULTRA RAIL MID CLAMP, SILVER
20	242-02215	SNAPNRACK, UNIVERSAL END CLAMP
20	232-02452	SNAPNRACK, UR-40 END CAP
26	242-02163	SNAPNRACK, UR SPEEDSEAL FOOT, SILVER
26	242-02168	SNAPNRACK, SEALING WASHER LAG, 4-1/2IN, SS
6	242-02101	SNAPNRACK, GROUND LUG ASSEMBLY, 6-12 AWG
1	051-03418	GROUNDING, LAY-IN LUG W/ SS BOLT AND STAR WASHER