

Lucent Engineering, P.C.

814 E 1475 N

Lehi, UT 84043

m: (309) 645-0999

admin@lucenteng.co

October 21, 2022

Encōr Solar, LLC
3049 Executive Pkwy, Ste 300
Lehi, UT 84043

RE: Engineering Services
Sanchez Residence
18 Surfwind Dr, Spring Lake, NC
7.32 kW System
Solo Job #2876430

To Whom It May Concern,

We have reviewed the following information regarding the solar panel installation for this project. Alterations to these documents or plans shall not be made without direct written consent of the Engineer of Record.

A. Assumptions from Field Observation provided by Encōr Solar, LLC

The following structural design regarding the proposed alterations have been prepared from these assumptions. The verification of the field observations is the responsibility of the contractor. **Prior to commencement of work, the contractor shall verify the framing sizes, spacings, and spans noted in the sealed plans, calculations, and/or certification letter and notify the Engineer of Record of any discrepancies.**

	<u>Roof</u>
Roof Finish :	Asphalt Shingle
Roof Underlayment :	OSB
Roof Profile :	Gable
Roof Structural System :	Metal Plate Trusses
Truss Top Chord/Setup :	2 x 4 / Double Howe
Chord/Rafter Wood Grade :	Southern Pine #2 or better
Truss/Rafter Spacing :	24" o.c.
Roof Slope :	32 deg
Max Top Chord/Rafter Span :	4.92 ft
Bearing Wall Type :	Convl Lt-Frame Constr
Foundation :	Permanent Concrete
Stories :	Single

B. Building Design Criteria

Code :	2018 NCRC (ASCE 7-10)	Risk Category :	II
Roof Live Load :	20 psf (0 psf at panels)	Occupancy Class :	R-3
Ground Snow Load :	10 psf	Roof Dead Load :	6.5 psf
Ult Wind Speed :	119 mph	PV Dead Load :	<u>3 psf</u>
Exposure Category :	C	Total Dead Load :	9.5 psf

C. Summary of Existing Structure Results

Roof

After review of the field observations and based on our calculations and in accordance with the applicable building codes and current industry standards, the existing roof structure supporting the proposed alterations consisting of the solar array has been determined to be:

- Adequate to support the additional imposed loads. **No structural upgrades are required.**

D. Solar Panel Support Bracket Anchorage

1. Solar panels shall be designed, mounted, and installed in accordance with the most recent "UniRac Manual", which can be found on the UniRac website (<http://unirac.com/>).
2. Manufacturer's Panel Bracket Connection to Roof Chord/Rafter Member:

Fastener : (1) 5/16" Lag Screw per Bracket
NDS Withdrawl Value : 307 lbs/inch
Min. Thread Length and Penetration Depth : 2.5"

3. Considering the existing roof's slope, size, spacing, condition, and calculated loads, the panel bracket supports shall be placed no greater than 72 in. o/c.
4. Panel supports connections shall be staggered to distribute load to adjacent trusses.

E. Overall Summary

Based on the information supplied to us at the time of this report, on the evaluation of the existing structure, and solar array panel bracket connection, it is our opinion that the roof system will adequately support the additional loads imposed by the solar array. This evaluation conforms to 2018 NCRC and current industry standards.

Should you have any questions regarding this letter or if you require further information, do not hesitate to contact me.

Sincerely,



Michael Leeper, PE
License No. 47119

10/21/2022

Limits of Scope of Work and Liability

The existing structure is assumed to have been designed and constructed following appropriate codes at the time of erection and assumed to have appropriated permits. The calculations performed are only for the roof framing supporting the solar array installation referenced in the stamped plans and were completed according to generally recognized structural analysis standards and procedures, professional engineering, and design experience opinions and judgements. Existing deficiencies which are unknown or were not observed during the time the site observation are not included in this scope of work. All solar panel modules, racking, and mounting equipment shall be designed and installed per the manufacturer's approved installation specifications. The Engineer of Record and the engineering consulting firm assume no responsibility for misuse or improper installation. This analysis is not stamped for water leakage. Framing was determined on information in provided plans and/or photos, along with engineering judgement. Prior to commencement of work, the contractor shall verify the framing sizes, spacings, and spans noted in the stamped plans, calculations, and/or certification letter and notify the Engineer of Record of any discrepancies prior to starting construction. If during solar panel installation, the roof framing members appear unstable or deflect non-uniformly, our office should be notified before proceeding with the installation. The contractor shall also verify that there are no damage/deficiencies (i.e., dry rot, water damage, termite damage, framing member/connection damage, etc.) to framing that was not addressed in the stamped plans, calculations, and/or certification letter and notify the Engineer of Record of any concerns prior to starting construction.

AERIAL VIEW:

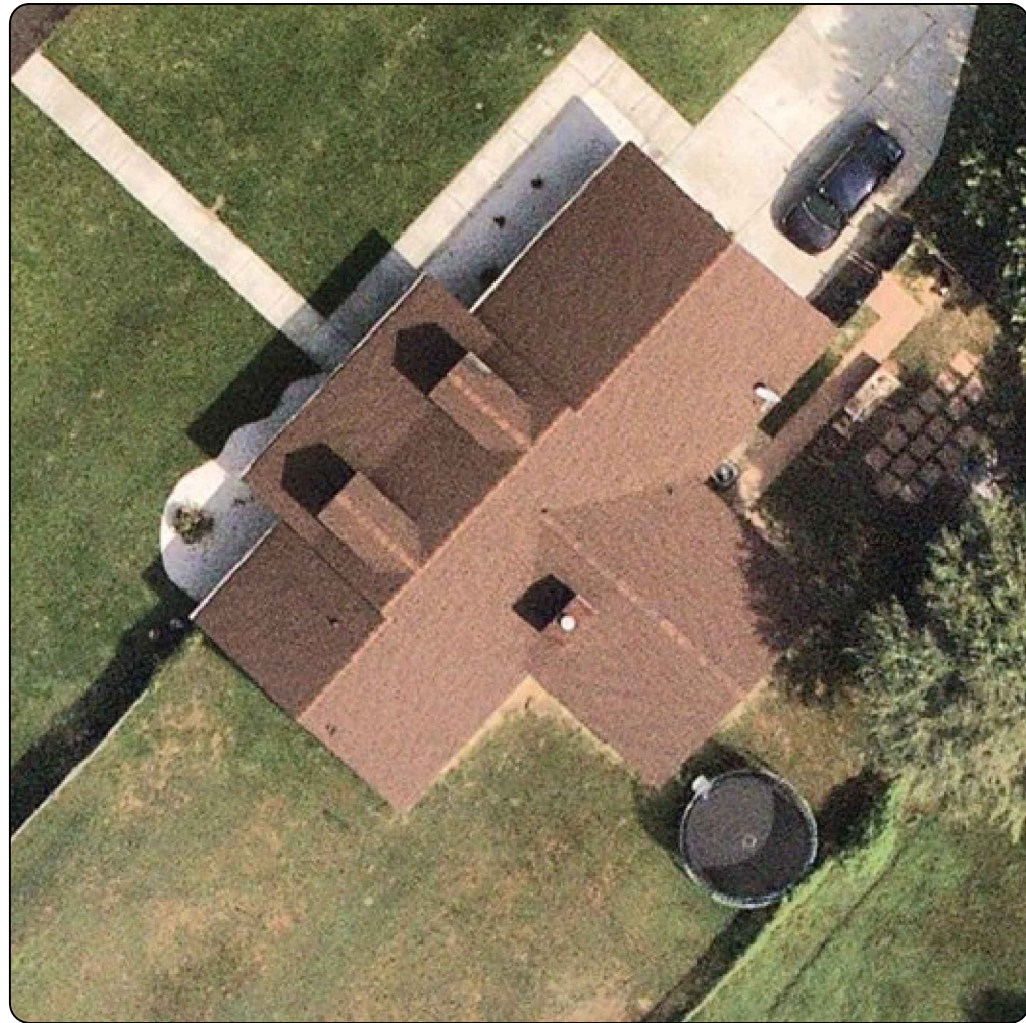

STREET VIEW:



CONTRACTOR INFORMATION:
ENCOR SOLAR, LLC
3049 Executive Parkway
Suite 300
Lehi, UT 84043
License # 32830

SITE INFORMATION

Rafael Sanchez
18 Surfwind Dr
Spring Lake, NC 28390
AC System Size: 7.329 kW AC
DC System Size: 8.505 kW DC
Lat, 35.241268
Long, -78.8797297999999
(21) Jinko Solar JKM405M-72HL-V
PV Modules
(21) Enphase IQ8A-72-2-US Inverter(s)

South River EMC

SHEET INDEX:

- PV01 COVER PAGE
- PV02 SITE PLAN
- PV03 ROOF ATTACHMENTS
- PV04 MOUNTING DETAIL
- PV05 LINE DIAGRAM
- PV06 ELECTRICAL CALCS
- PV07 LABELS
- PV08 PLACARD
- PV09 SITE PHOTOS

DRAWN BY: SoloCAD

DATE:
October 20, 2022

COVER PAGE - PV01

GENERAL NOTES

1. INSTALLATION OF SOLAR PHOTOVOLTAIC SYSTEM SHALL BE IN ACCORDANCE WITH NEC ARTICLE 690, AND ALL OTHER APPLICABLE NEC CODES WHERE NOTED OR EXISTING
2. PROPER ACCESS AND WORKING CLEARANCE AROUND EXISTING AND PROPOSED ELECTRICAL EQUIPMENT WILL COMPLY WITH NEC ARTICLE 110
3. ALL WIRES, INCLUDING THE GROUNDING ELECTRODE CONDUCTOR SHALL BE PROTECTED FROM PHYSICAL DAMAGE IN ACCORDANCE WITH NEC ARTICLE 250
4. THE PV MODULES ARE CONSIDERED NON-COMBUSTIBLE; THIS SYSTEM IS UTILITY INTERACTIVE PER UL 1741 AND DOES NOT INCLUDE STORAGE BATTERIES OR OTHER ALTERNATIVE STORAGE SOURCES
5. ALL DC WIRES SHALL BE SIZED ACCORDING TO [NEC 690.8]
6. DC CONDUCTORS SHALL BE WITHIN PROTECTED RACEWAYS IN ACCORDANCE WITH [NEC 690.31]
7. ALL SIGNAGE TO BE PLACED IN ACCORDANCE WITH LOCAL JURISDICTIONAL BUILDING CODE

PHOTOVOLTAIC (PV) SYSTEM SPECIFICATIONS

AC System Size: 7.329 kW AC
DC System Size: 8.505 kW DC
(21) Jinko Solar JKM405M-72HL-V PV Modules
(21) Enphase IQ8A-72-2-US Inverter(s)
Racking: Unirac - FLASHKIT PRO - 72" O.C.

APPLICABLE GOVERNING CODES

2020 NATIONAL ELECTRICAL CODE
2018 NORTH CAROLINA STATE BUILDING CODE: RESIDENTIAL
2018 NORTH CAROLINA STATE BUILDING CODE: BUILDING
2018 NORTH CAROLINA STATE BUILDING CODE: FIRE

SITE SPECIFICATIONS

OCCUPANCY: R-3
ZONING: RESIDENTIAL



10/21/2022

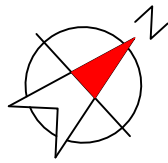

ARRAY DETAILS:		
MOUNTING PLANE:	AZIMUTH:	TILT:
MP1	132°	32°

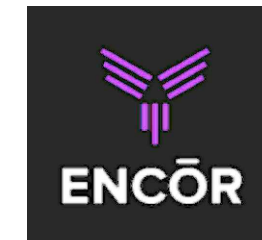
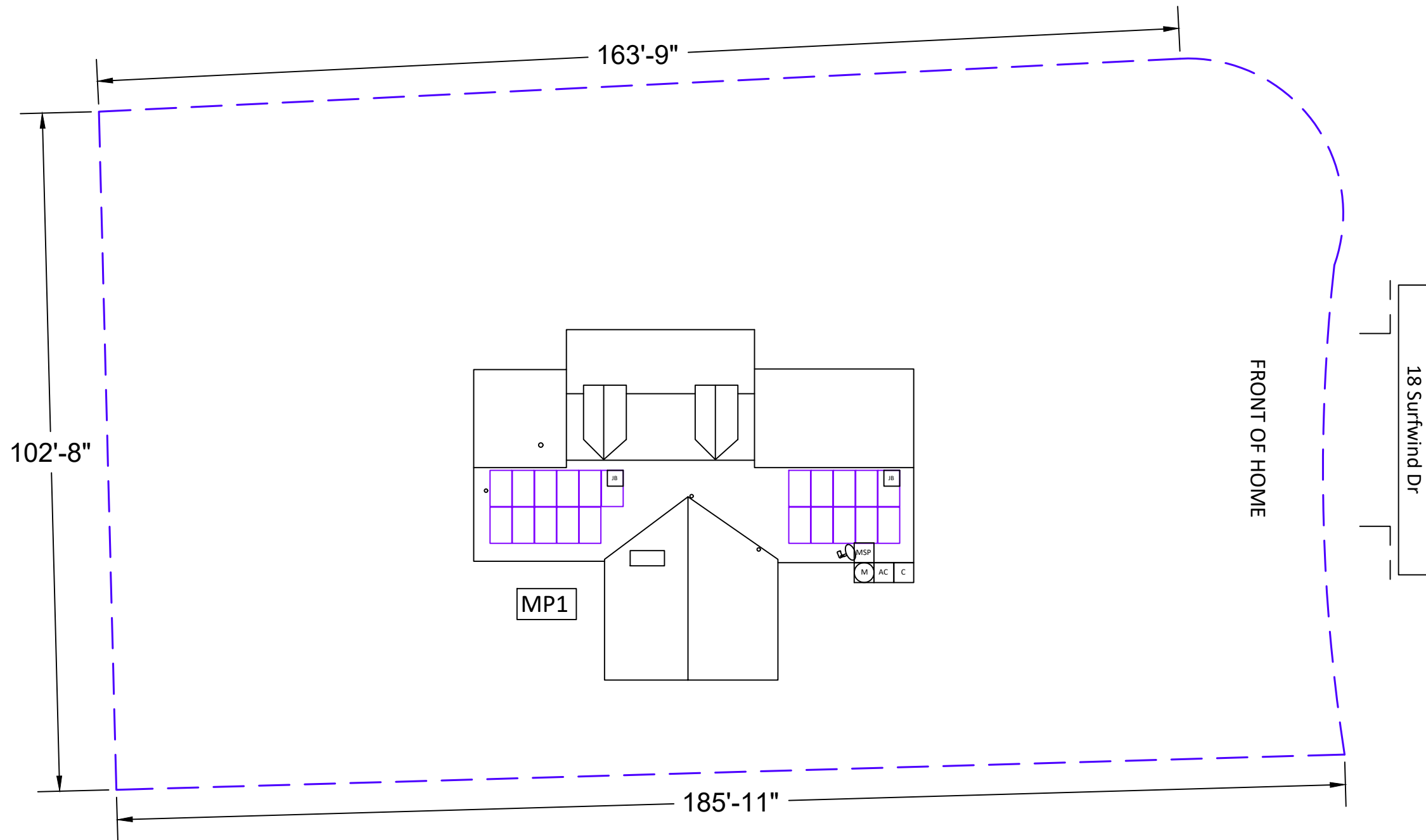

CONTRACTOR INFORMATION:
 ENCOR SOLAR, LLC
 3049 Executive Parkway
 Suite 300
 Lehi, UT 84043
 License # 32830

SITE INFORMATION

Rafael Sanchez
 18 Surfwind Dr
 Spring Lake, NC 28390
 AC System Size: 7.329 kW AC
 DC System Size: 8.505 kW DC
 Lat, 35.241268
 Long, -78.8797297999999
 (21) Jinko Solar JKM405M-72HL-V
 PV Modules
 (21) Enphase IQ8A-72-2-US Inverter(s)

South River EMC

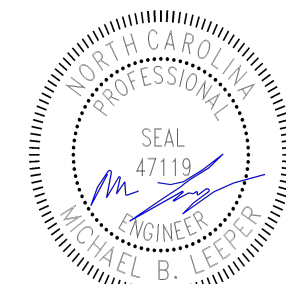

10/21/2022

EQUIPMENT LEGEND:

- UTILITY METER
- VISIBLE, LOCKABLE, LABELED AC DISCONNECT
- INVERTER
- SUB PANEL
- SERVICE DISCONNECT
- PV MODULES
- FIRE ACCESS PATHWAY (3' TYP)
- MAIN SERVICE PANEL
- METER SOCKET (FOR UTILITY PV METER)
- COMBINER BOX
- LOAD CENTER
- BATTERY(IES)
- JUNCTION BOX
- PROPERTY LINE

VISIBLE, LOCKABLE, LABELED AC DISCONNECT LOCATED WITHIN 10' OF UTILITY METER

DRAWN BY: SoloCAD
 DATE:
 October 20, 2022
 SITE PLAN - PV02

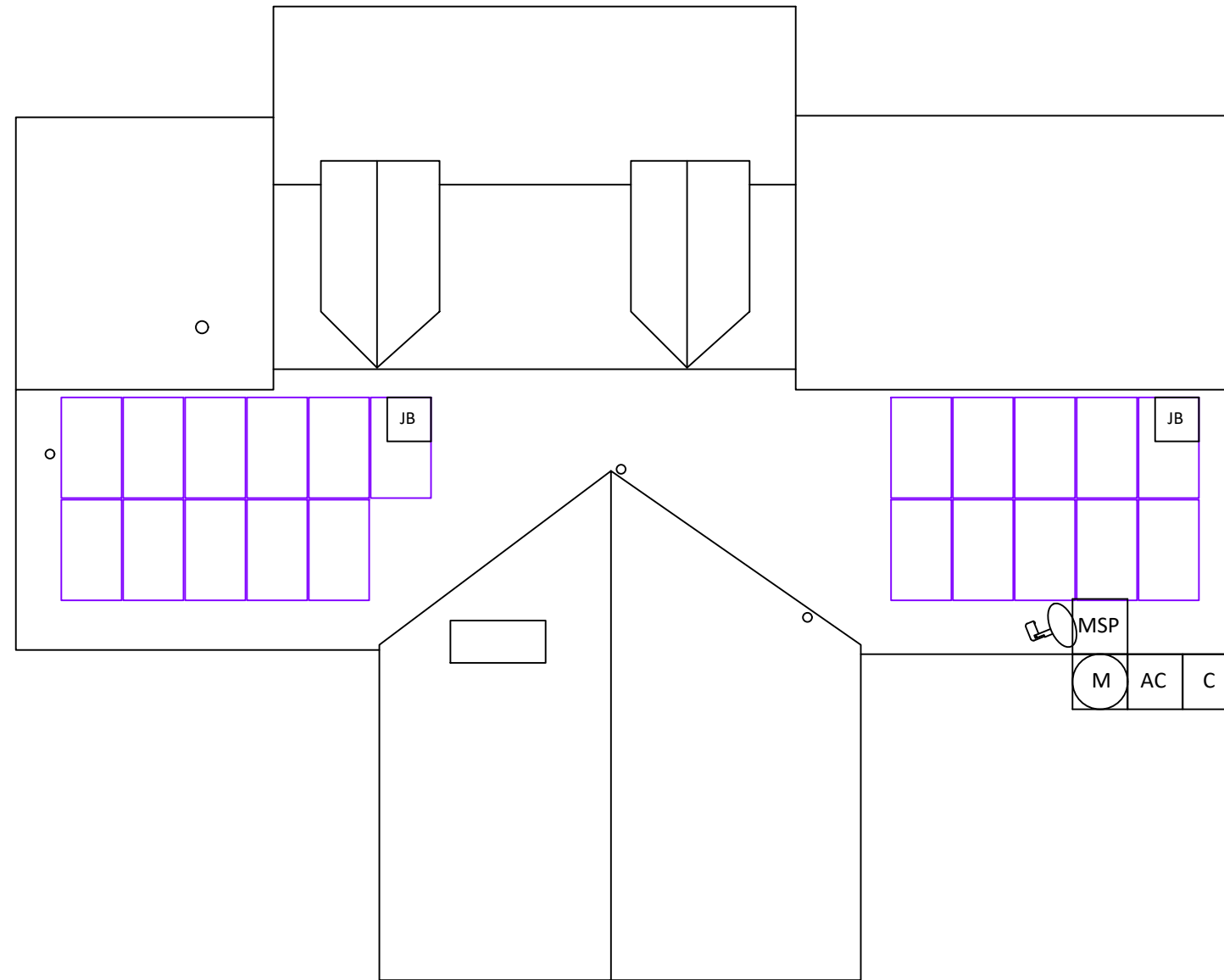
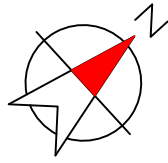

CONTRACTOR INFORMATION:
 ENCOR SOLAR, LLC
 3049 Executive Parkway
 Suite 300
 Lehi, UT 84043
 License # 32830

SITE INFORMATION

Rafael Sanchez
 18 Surfwind Dr
 Spring Lake, NC 28390
 AC System Size: 7.329 kW AC
 DC System Size: 8.505 kW DC
 Lat, 35.241268
 Long, -78.8797297999999
 (21) Jinko Solar JKM405M-72HL-V
 PV Modules
 (21) Enphase IQ8A-72-2-US Inverter(s)

South River EMC

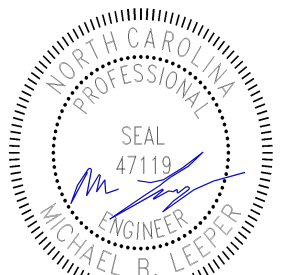

10/21/2022

DRAWN BY: SoloCAD

DATE:
 October 20, 2022

ROOF ATTACHMENTS - PV03

EQUIPMENT INFORMATION:		ROOF INFO:		PHOTOVOLTAIC ARRAY STRUCTURAL CRITERIA:	
RAIL MANUFACTURER:	SnapNrack	ROOF TYPE:	Asphalt Shingle	PV MODULE COUNT:	21
RAIL PART NUMBER:	Standard Rail	ROOF FRAMING:	Manufactured Truss	ARRAY AREA:	MODULE COUNT * 21.66 ft ² = 454.86
ATTACHMENTS	Unirac - FLASHKIT PRO	RAFTER/TOP CHORD SIZE:	2x4	ROOF AREA:	2581 ft ²
ATTACHMENT QTY:	33	RAFTER/TOP CHORD SPACING:	24"	PERCENT OF ROOF COVERED:	18%
SPLICE QTY:	8	ATTACHMENT SPACING:	72"	ARRAY WEIGHT:	MODULE COUNT * 50 lbs = 1050 lbs
MIDCLAMP QTY:	34			POINT LOAD:	ARRAY LBS/ATTACHMENTS = 31.82
ENDCLAMP QTY:	16			DISTRIBUTED LOAD: (lbs/ft ²)	(ARRAY) WEIGHT/AREA = 2.31 lbs/ft ²

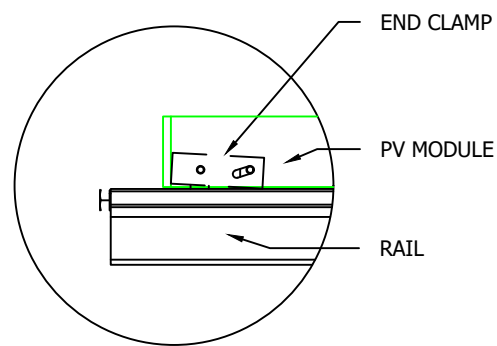

1 END CLAMP DETAILS

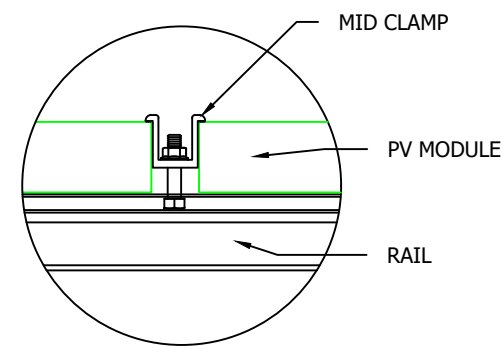

2 MID CLAMP DETAILS

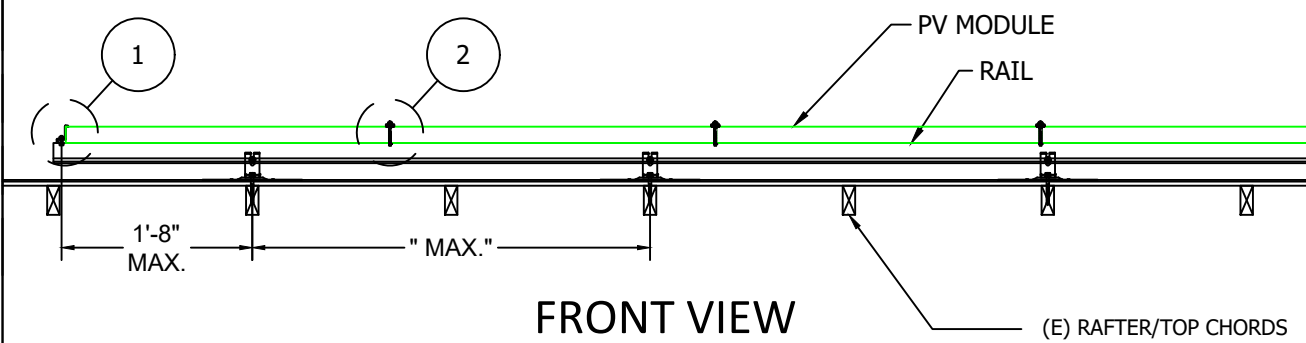

FRONT VIEW

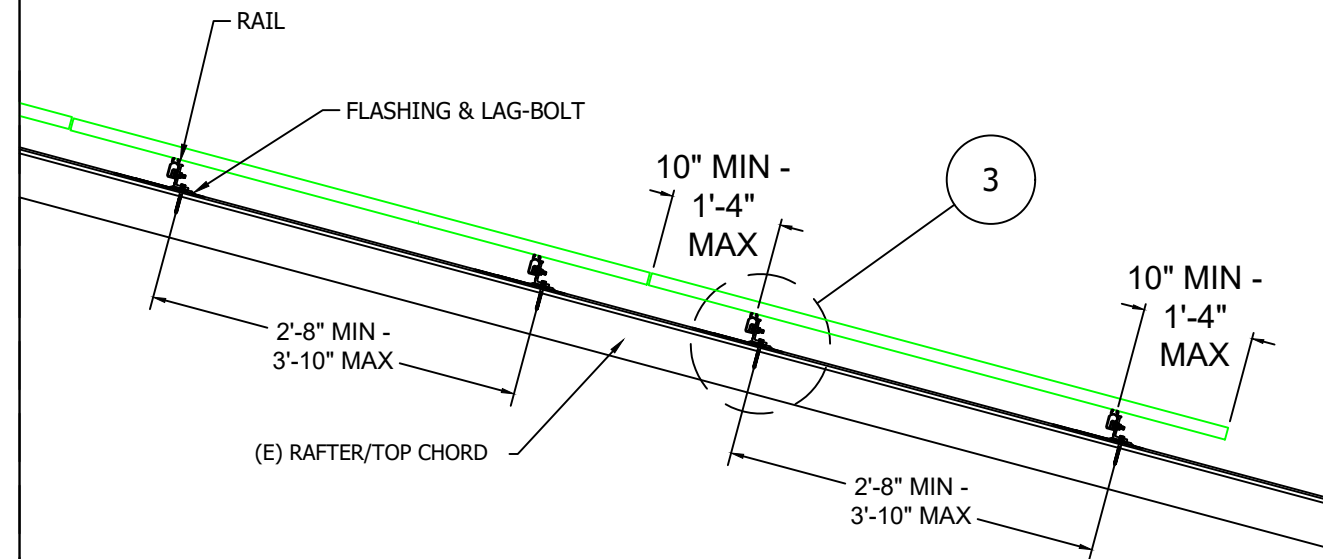

SIDE VIEW

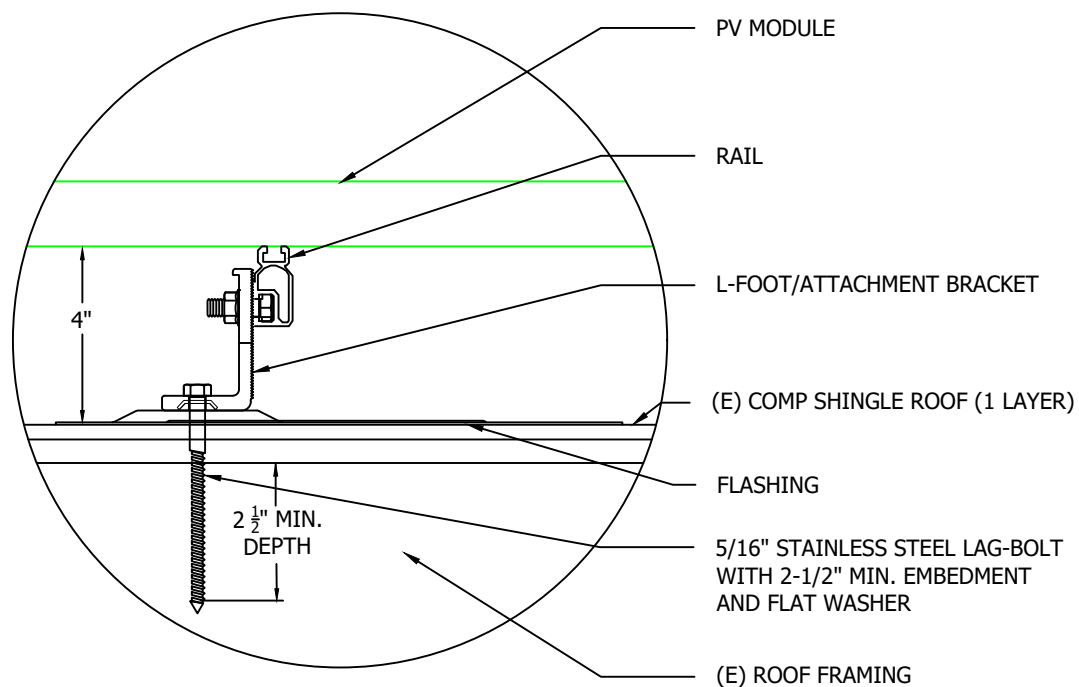

3 DETAIL, MOUNTING AND FLASHING

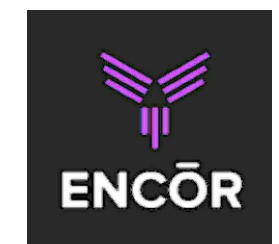

CONTRACTOR INFORMATION:
ENCOR SOLAR, LLC
 3049 Executive Parkway
 Suite 300
 Lehi, UT 84043
 License # 32830

SITE INFORMATION

Rafael Sanchez
 18 Surfwind Dr
 Spring Lake, NC 28390
 AC System Size: 7.329 kW AC
 DC System Size: 8.505 kW DC
 Lat, 35.241268
 Long, -78.8797297999999
 (21) Jinko Solar JKM405M-72HL-V
 PV Modules
 (21) Enphase IQ8A-72-2-US Inverter(s)

South River EMC



DRAWN BY: SoloCAD

DATE:
 October 20, 2022

MOUNTING DETAIL - PV04

EQUIPMENT INFORMATION:		ROOF INFO:		PHOTOVOLTAIC ARRAY STRUCTURAL CRITERIA:	
RAIL MANUFACTURER:	SnapNrack	ROOF TYPE:	Asphalt Shingle	PV MODULE COUNT:	21
RAIL PART NUMBER:	Standard Rail	ROOF FRAMING:	Manufactured Truss	ARRAY AREA:	MODULE COUNT * 21.66 ft ² = 454.86
ATTACHMENTS	Unirac - FLASHKIT PRO	RAFTER/TOP CHORD SIZE:	2x4	ROOF AREA:	2581 ft ²
ATTACHMENT QTY:	33	RAFTER/TOP CHORD SPACING:	24"	PERCENT OF ROOF COVERED:	18%
SPLICE QTY:	8	ATTACHMENT SPACING:	72"	ARRAY WEIGHT:	MODULE COUNT * 50 lbs = 1050 lbs
MIDCLAMP QTY:	34			POINT LOAD:	ARRAY LBS/ATTACHMENTS = 31.82
ENDCLAMP QTY:	16			DISTRIBUTED LOAD: (lbs/ft ²)	(ARRAY) WEIGHT/AREA = 2.31 lbs/ft ²

Jinko Solar JKM405M-72HL-V Specs	
POWER MAX (P _{MAX}):	405 W
OPEN CIRCUIT VOLTAGE (V _{OC}):	50.1 V
MAX POWER-POINT CURRENT (I _{MP}):	9.65 A
MAX POWER-POINT VOLTAGE (V _{MPP}):	42 V
SHORT CIRCUIT CURRENT (I _{SC}):	10.48 A
SERIES FUSE RATING:	20A

Enphase IQ8A-72-2-US Specs	
MAX INPUT VOLTAGE:	60 V
MAX DC SHORT CIRCUIT CURRENT:	15 A
MAXIMUM OUTPUT POWER:	349 W
MAXIMUM OUTPUT CURRENT:	1.45 A
NOM. OUTPUT VOLTAGE:	240 V
MAX UNITS PER 20A CIRCUIT:	11
1-Phase, 60 HZ, UL 1741 Listed	

Equipment Schedule				
TYPE:	QTY:	DESCRIPTION:	RATING:	
MODULES:	(21)	Jinko Solar JKM405M-72HL-V	405 W	
INVERTERS:	(21)	Enphase IQ8A-72-2-US	349 W	
AC DISCONNECT(S):	(1)	PV AC Disconnect, 240V, 2-Pole	60 A	
AC COMBINER:	(1)	Enphase (X-IQ-AM 1-240-4)	125 A	

Conduit & Conductor Schedule				
TAG	QTY	WIRE GAUGE	DESCRIPTION	CONDUIT SIZE
1	(2)	12-2	ENPHASE Q-CABLE ALUMINUM - (L1, L2)	N/A - FREE AIR
	(1)	6 AWG	THWN-2 COPPER - (GROUND)	
2	(2)	10 AWG	THHN/THWN-2 COPPER - (L1, L2)	3/4" EMT
	(1)	10 AWG	THWN-2 COPPER - (GROUND)	
3	(4)	10 AWG	THHN/THWN-2 (L1, L2)	3/4" EMT
	(1)	10 AWG	THWN-2 COPPER -(GROUND)	
4	(3)	8 AWG	THWN-2 COPPER - (L1, L2, NEUTRAL)	3/4" EMT
	(1)	10 AWG	THWN-2 COPPER - (GROUND)	



CONTRACTOR INFORMATION:
ENCOR SOLAR, LLC
 3049 Executive Parkway
 Suite 300
 Lehi, UT 84043
 License # 32830

SITE INFORMATION

Rafael Sanchez
 18 Surfwind Dr
 Spring Lake, NC 28390
 AC System Size: 7.329 kW AC
 DC System Size: 8.505 kW DC
 Lat, 35.241268
 Long, -78.8797297999999
 (21) Jinko Solar JKM405M-72HL-V
 PV Modules
 (21) Enphase IQ8A-72-2-US Inverter(s)

South River EMC

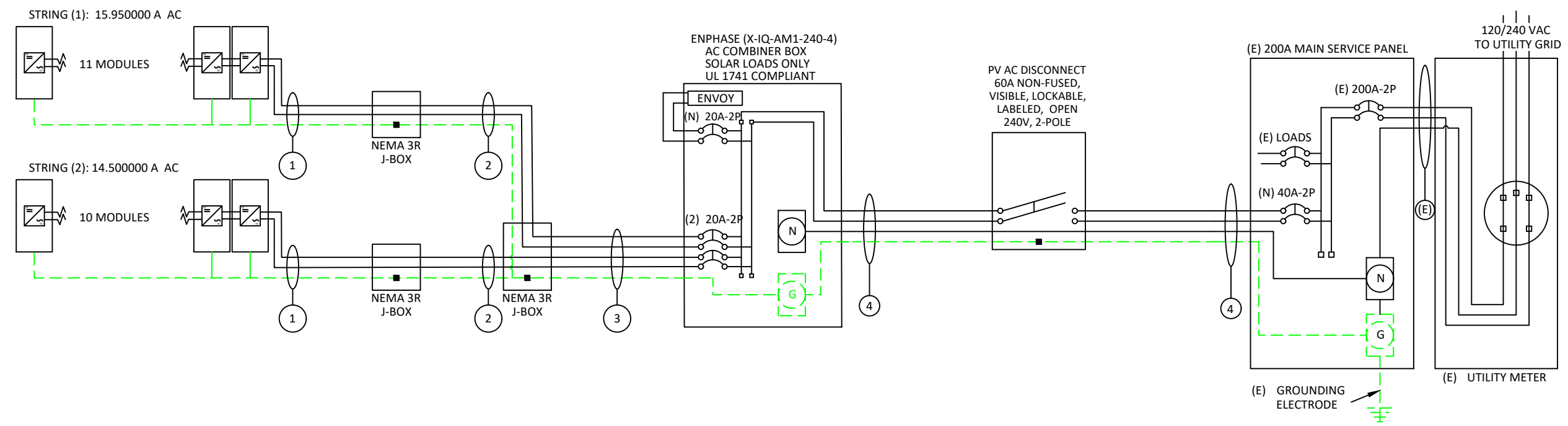

VISIBLE, LOCKABLE,
 LABELED AC DISCONNECT
 LOCATED WITHIN 10'
 OF UTILITY METER

DRAWN BY: SoloCAD
 DATE:
 October 20, 2022
LINE DIAGRAM - PV05

STRING CALCULATIONS		
Enphase IQ8A-72-2-US	STRING #1	STRING #2
MAX AC CURRENT:	15.95A	14.50A
MICRO INVERTERS IN SERIES	11	10
NOMINAL STRING VOLTAGE:	240V	240V
MAX AC OUTPUT POWER	3839.00W	3490.00W
ARRAY DC POWER:	8505W	
TOTAL MAX AC CURRENT:	30.450000A	

SYSTEM OCPD CALCULATIONS	
INVERTER MODEL(S):	Enphase IQ8A-72-2-US
# OF INVERTERS:	21
MAX OUTPUT CURRENT:	1.45A
(# OF INVERTERS) X (MAX OUTPUT CURRENT) X 125% <= OCPD RATING	
(21 X 1.45A X 1.25) = 38.0625A <= 40A, OK	

NUMBER OF CURRENT CARRYING CONDUCTORS	PERCENT OF VALUES
4-6	.80
7-9	.70
10-20	.50

BUSBAR CALCULATIONS - 120% RULE	
MAIN BUSBAR RATING:	200A
MAIN DISCONNECT RATING:	200A
PV OCPD RATING:	40A
(MAIN BUS RATING X 120%) - MAIN DISCONNECT RATING >= OCPD RATING	
(200A X 1.2) - 200A = 40A, >= 40A, OK	

Conduit & Conductor Schedule											
TAG	QTY	WIRE GAUGE	DESCRIPTION	CONDUIT SIZE	CONDUCTOR RATING	CONDUCTOR TEMP. RATE	AMBIENT TEMP	TEMP. DERATE	# OF CONDUCTORS DERATE	CONDUCTOR RATING W/DERATES	CONDUIT FILL
1	(2)	12-2	ENPHASE Q-CABLE ALUMINUM - (L1, L2)	N/A - FREE AIR	25A	90°C	35°C	0.96	N/A - FREE AIR	24A	N/A - FREE AIR
	(1)	6 AWG	THWN-2 COPPER - (GROUND)								
2	(2)	10 AWG	THHN/THWN-2 COPPER - (L1, L2)	3/4" EMT	40A	90°C	35°C	0.96	1	38.4A	11.9%
	(1)	10 AWG	THWN-2 COPPER - (GROUND)								
3	(4)	10 AWG	THHN/THWN-2 (L1, L2)	3/4" EMT	40A	90°C	35°C	0.96	0.8	30.72A	19.8%
	(1)	10 AWG	THWN-2 COPPER -(GROUND)								
4	(3)	8 AWG	THWN-2 COPPER - (L1, L2, NEUTRAL)	3/4" EMT	50A	75°C	35°C	0.94	1	47A	24.6%
	(1)	10 AWG	THWN-2 COPPER - (GROUND)								



CONTRACTOR INFORMATION:
ENCOR SOLAR, LLC
 3049 Executive Parkway
 Suite 300
 Lehi, UT 84043
 License # 32830

SITE INFORMATION

Rafael Sanchez
 18 Surfwind Dr
 Spring Lake, NC 28390
 AC System Size: 7.329 kW AC
 DC System Size: 8.505 kW DC
 Lat, 35.241268
 Long, -78.8797297999999
 (21) Jinko Solar JKM405M-72HL-V
 PV Modules
 (21) Enphase IQ8A-72-2-US Inverter(s)

South River EMC

DRAWN BY: SoloCAD

DATE:
 October 20, 2022

ELECTRICAL CALCS - PV06

GROUNDING & GENERAL NOTES:

- PV INVERTER IS UNGROUNDED, TRANSFORMER-LESS TYPE.
- DC GEC AND AC EGC TO BE SPICED TO EXISTING ELECTRODE
- ANY EXISTING WIRING INVOLVED WITH PV SYSTEM CONNECTION THAT IS FOUND TO BE INADEQUATE PER CODE SHALL BE CORRECTED PRIOR TO FINAL INSPECTION.
- JUNCTION BOX QUANTITIES, AND PLACEMENT SUBJECT TO CHANGE IN THE FIELD - JUNCTION BOXES DEPICTED ON ELECTRICAL DIAGRAM REPRESENT WIRE TYPE TRANSITIONS.
- AC DISCONNECT NOTED IN EQUIPMENT SCHEDULE OPTIONAL IF OTHER AC DISCONNECTING MEANS IS LOCATED WITHIN 10' OF SERVICE DISCONNECT.

INTERCONNECTION NOTES:

- INTERCONNECTION SIZING, LIMITATIONS AND COMPLIANCE DETERMINED IN ACCORDANCE WITH [NEC 705.12].
- GROUND FAULT PROTECTION IN ACCORDANCE WITH [NEC 215.9], [NEC 230.95] AND [NEC 690.41]
- ALL EQUIPMENT TO BE RATED FOR BACKFEEDING.
- PV BREAKER TO BE POSITIONED AT THE OPPOSITE END OF THE BUSBAR RELATIVE TO THE MAIN BREAKER.

DISCONNECT NOTES:

- DISCONNECTING SWITCHES SHALL BE WIRED SUCH THAT WHEN THE SWITCH IS OPENED THE CONDUCTORS REMAINING LIVE ARE CONNECTED TO THE TERMINALS MARKED "LINE SIDE" (TYPICALLY THE UPPER TERMINALS)
- AC DISCONNECT MUST BE ACCESSIBLE TO QUALIFIED UTILITY PERSONNEL, BE LOCKABLE, AND BE A VISIBLE-BREAK SWITCH

MAIN PHOTOVOLTAIC SYSTEM DISCONNECT

LABEL 1
PLACED ON THE MAIN DISCONNECTING MEANS FOR THE PV SYSTEM.
[NEC 690.13(B)]

WARNING
ELECTRIC SHOCK HAZARD
TERMINALS ON THE LINE AND
LOAD SIDES MAY BE ENERGIZED
IN THE OPEN POSITION

LABEL 2
FOR PV DISCONNECTING MEANS WHERE THE LINE AND
LOAD TERMINALS MAY BE ENERGIZED IN THE OPEN
POSITION.
[NEC 690.13(B)]

WARNING
POWER SOURCE OUTPUT CONNECTION.
DO NOT RELOCATE THIS OVERCURRENT DEVICE.

LABEL 3
PLACED ADJACENT TO THE BACK-FED BREAKER FROM
THE INVERTER IF TIE IN CONSISTS OF LOAD SIDE
CONNECTION TO BUSBAR.
[NEC 705.12(B)(3)(2)]

CAUTION
MULTIPLE SOURCES OF POWER

LABEL 4
PLACED ON EQUIPMENT CONTAINING OVERCURRENT
DEVICES IN CIRCUITS SUPPLYING POWER TO
A BUSBAR OR CONDUCTOR SUPPLIED FROM MULTIPLE
SOURCES
[NEC 705.10]

WARNING
THIS EQUIPMENT IS FED BY MULTIPLE
SOURCES. TOTAL RATING OF ALL
OVERCURRENT DEVICES, EXCLUDING
MAIN SUPPLY OVERCURRENT
DEVICE, SHALL NOT EXCEED
AMPACITY OF BUSBAR.

LABEL 5
EQUIPMENT CONTAINING OVERCURRENT
DEVICES IN CIRCUITS SUPPLYING POWER TO A
BUSBAR OR CONDUCTOR SUPPLIED FROM
MULTIPLE SOURCES SHALL BE MARKED TO
INDICATE THE PRESENCE OF ALL SOURCES.[NEC
705.12(B)(3)(3)]

PHOTOVOLTAIC AC DISCONNECT

RATED AC OUTPUT CURRENT: 30
NOMINAL OPERATING AC VOLTAGE: 240

LABEL 6
MARKED AT AC DISCONNECTING MEANS.
[NEC 690.54]

PHOTOVOLTAIC POWER SOURCE

SOLAR PV SYSTEM EQUIPPED WITH RAPID SHUTDOWN

TURN RAPID SHUTDOWN
SWITCH TO THE "OFF"
POSITION TO SHUT DOWN
PV SYSTEM AND REDUCE
SHOCK HAZARD IN ARRAY

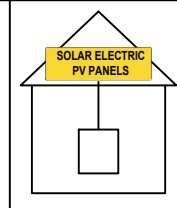

LABEL 7
AT DIRECT-CURRENT EXPOSED RACEWAYS, CABLE TRAYS, COVERS AND
ENCLOSURES OF JUNCTION BOXES, AND OTHER WIRING METHODS; SPACED
AT MAXIMUM 10FT SECTION OR WHERE SEPARATED BY ENCLOSURES, WALLS,
PARTITIONS, CEILINGS, OR FLOORS.
[NEC 690.31(D)(2)]

LABEL 8
FOR PV SYSTEMS THAT SHUT DOWN THE ARRAY AND CONDUCTORS
LEAVING THE ARRAY:
SIGN TO BE LOCATED ON OR NO MORE THAN 3 FT AWAY FROM
SERVICE DISCONNECTING MEANS TO WHICH THE PV SYSTEMS ARE
CONNECTED AND SHALL INDICATE THE LOCATION OF ALL IDENTIFIED
RAPID SHUTDOWN SWITCHES IF NOT AT THE SAME LOCATION.
[NEC 690.56(C)(1)]

RAPID SHUTDOWN SWITCH FOR SOLAR PV SYSTEM

LABEL 9
SIGN LOCATED ON OR NO MORE THAN 3FT
FROM INITIATION DEVICE
[NEC 690.56(C)(2)].



CONTRACTOR INFORMATION:
ENCOR SOLAR, LLC
3049 Executive Parkway
Suite 300
Lehi, UT 84043
License # 32830

SITE INFORMATION

Rafael Sanchez
18 Surfwind Dr
Spring Lake, NC 28390
AC System Size: 7.329 kW AC
DC System Size: 8.505 kW DC
Lat, 35.241268
Long, -78.8797297999999
(21) Jinko Solar JKM405M-72HL-V
PV Modules
(21) Enphase IQ8A-72-2-US Inverter(s)

South River EMC

LABELING NOTES:

1. LABELS CALLED OUT ACCORDING TO ALL COMMON CONFIGURATIONS. ELECTRICIAN TO DETERMINE EXACT REQUIREMENTS IN THE FIELD PER CURRENT NEC AND LOCAL CODES AND MAKE APPROPRIATE ADJUSTMENTS.
2. LABELING REQUIREMENTS BASED ON THE 2020 NATIONAL ELECTRIC CODE, OSHA STANDARD 19010.145, ANSI Z535.
3. MATERIAL BASED ON THE REQUIREMENTS OF THE AUTHORITY HAVING JURISDICTION.
4. LABELS TO BE OF SUFFICIENT DURABILITY TO WITHSTAND THE ENVIRONMENT INVOLVED [NEC 110.21]
5. LABELS TO BE A MINIMUM LETTER HEIGHT OF 3/8", WHITE ON RED BACKGROUND; REFLECTIVE, AND PERMANENTLY AFFIXED [NEC 690.31(D)(2)]

LABELING DIAGRAM:

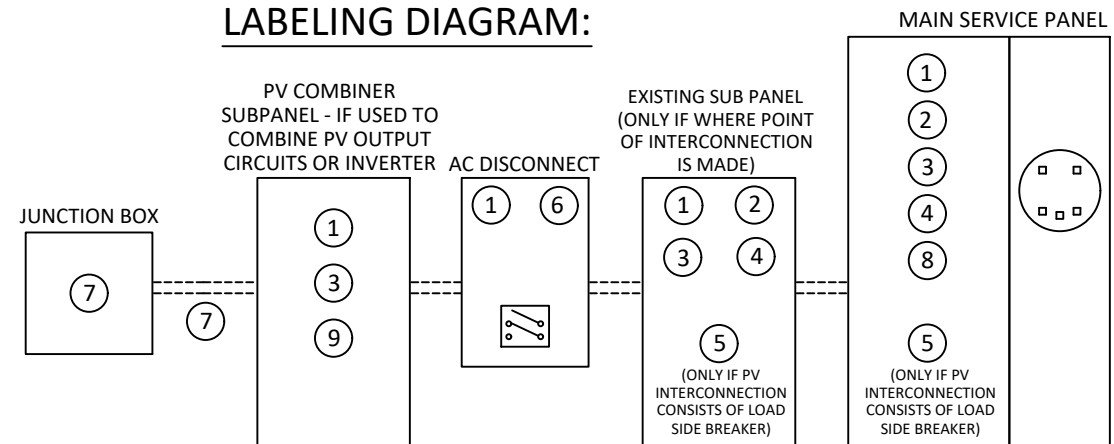

** ELECTRICAL DIAGRAM SHOWN ABOVE IS FOR LABELING PURPOSES ONLY. NOT AN ACTUAL REPRESENTATION OF EQUIPMENT AND CONNECTIONS TO BE INSTALLED. LABEL LOCATIONS PRESENTED MAY VARY DEPENDING ON TYPE OF INTERCONNECTION METHOD AND LOCATION PRESENTED ELECTRICAL DIAGRAM PAGE. **

DRAWN BY: SoloCAD

DATE:
October 20, 2022

LABELS - PV07

CAUTION

POWER TO THIS BUILDING IS ALSO SUPPLIED FROM ROOF MOUNTED SOLAR ARRAYS WITH SAFETY DISCONNECTS AS SHOWN:

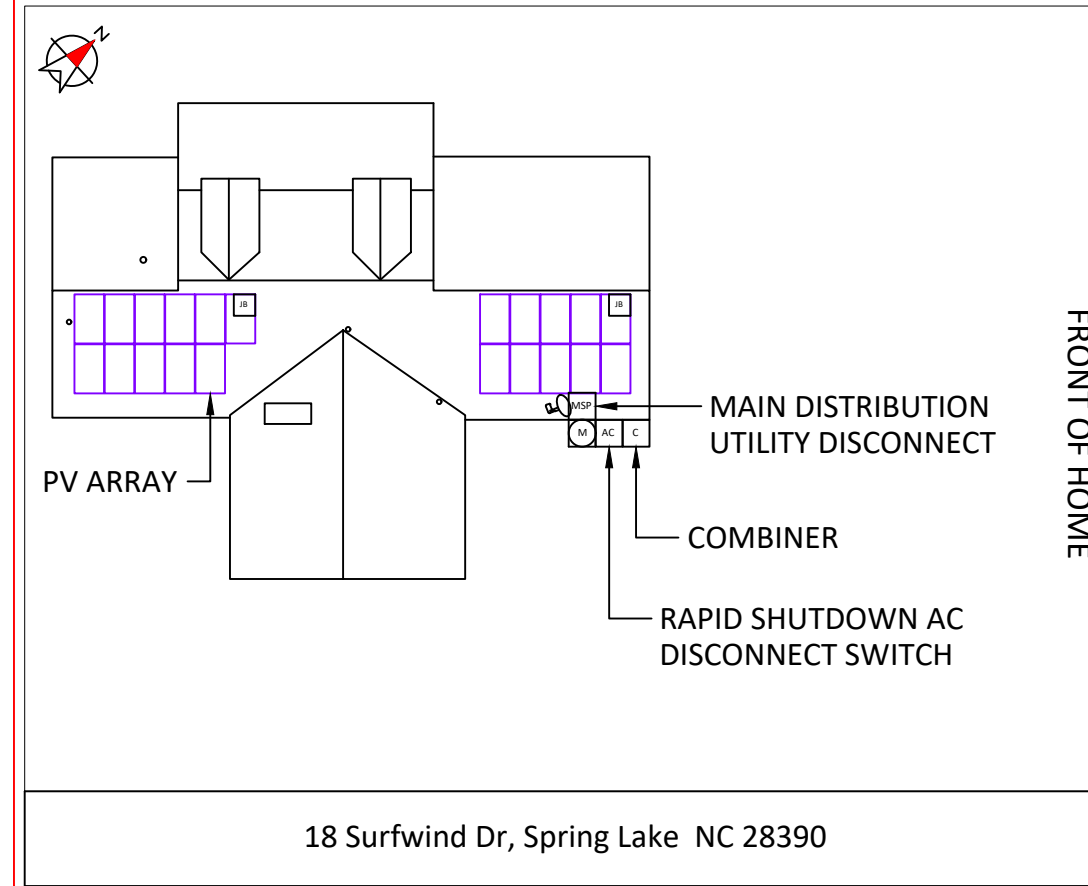

DIRECTORY

PERMANENT PLAQUE OR DIRECTORY PROVIDING THE LOCATION OF THE SERVICE DISCONNECTING MEANS AND THE PHOTOVOLTAIC SYSTEM.

(ALL PLAQUES AND SIGNAGE WILL BE INSTALLED AS OUTLINED WITHIN:
NEC 690.56(B)&(C), [NEC 705.10])



CONTRACTOR INFORMATION:

ENCOR SOLAR, LLC
3049 Executive Parkway
Suite 300
Lehi, UT 84043
License # 32830

SITE INFORMATION

Rafael Sanchez

18 Surfwind Dr

Spring Lake, NC 28390

AC System Size: 7.329 kW AC

DC System Size: 8.505 kW DC

Lat, 35.241268

Long, -78.8797297999999

(21) Jinko Solar JKM405M-72HL-V
PV Modules

(21) Enphase IQ8A-72-2-US Inverter(s)

South River EMC

DRAWN BY: SoloCAD

DATE:
October 20, 2022

PLACARD - PV08

SITE PHOTOS:



CONTRACTOR INFORMATION:
ENCOR SOLAR, LLC
3049 Executive Parkway
Suite 300
Lehi, UT 84043
License # 32830

SITE INFORMATION

Rafael Sanchez
18 Surfwind Dr
Spring Lake, NC 28390
AC System Size: 7.329 kW AC
DC System Size: 8.505 kW DC
Lat, 35.241268
Long, -78.8797297999999
(21) Jinko Solar JKM405M-72HL-V
PV Modules
(21) Enphase IQ8A-72-2-US Inverter(s)

South River EMC



DRAWN BY: SoloCAD

DATE:
October 20, 2022

SITE PHOTOS - PV09

Eagle 72HM G2

390-410 Watt

MONO PERC HALF CELL MODULE

Positive power tolerance of 0~+3%

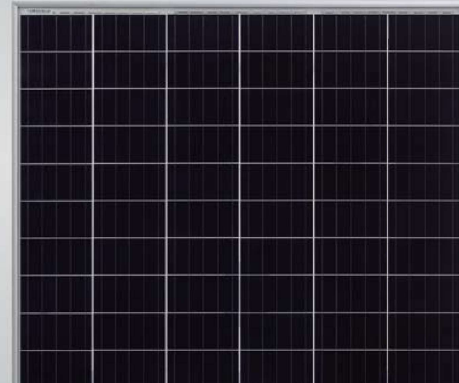

KEY FEATURES

- Diamond Cell Technology**
Uniquely designed high performance 5 busbar mono PERC half cell
- 1500V High Voltage**
UL and IEC 1500V certified; lowers BOS costs and yields better LCOE
- Higher Module Power**
Decrease in current loss yields higher module efficiency
- Shade Tolerance**
More shade tolerance due to twin arrays
- PID FREE**
Reinforced cell prevents potential induced degradation
- Strength and Durability**
Certified for high snow (5400Pa) and wind (2400 Pa) loads

- ISO9001:2008 Quality Standards
- ISO14001:2004 Environmental Standards
- OHSAS18001 Occupational Health & Safety Standards
- IEC61215, IEC61730 certified products
- UL1703 certified products

Nomenclature:

JKM410M-72HL-V

Code	Cell	Code	Cell	Code	Certification
null	Full	null	Normal	null	1000V
H	Half	L	Diamond	V	1500V



LINEAR PERFORMANCE WARRANTY

12 Year Product Warranty • 25 Year Linear Power Warranty

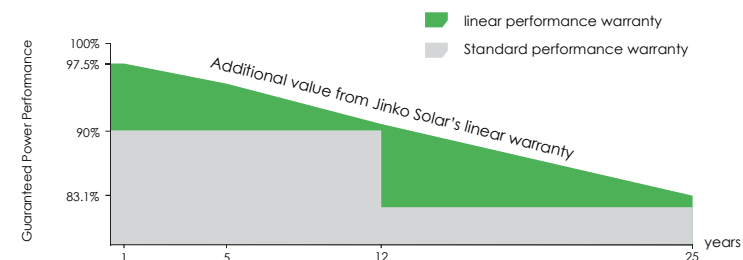

Engineering Drawings

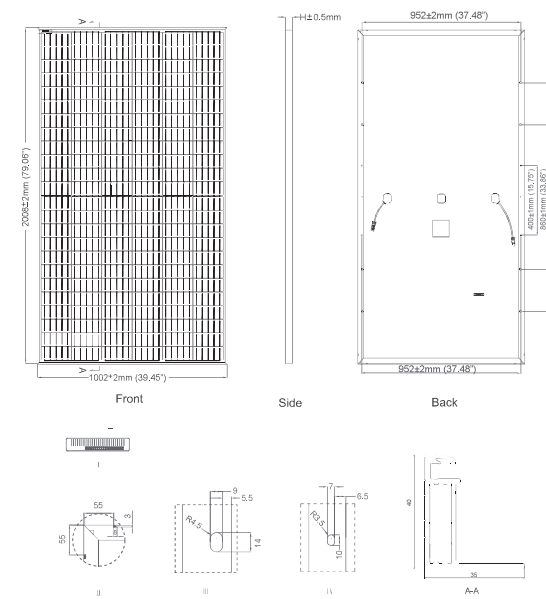

Packaging Configuration

(Two pallets = One stack)
27pcs/pallet, 54pcs/stack, 594pcs/40' HQ Container

Electrical Performance & Temperature Dependence

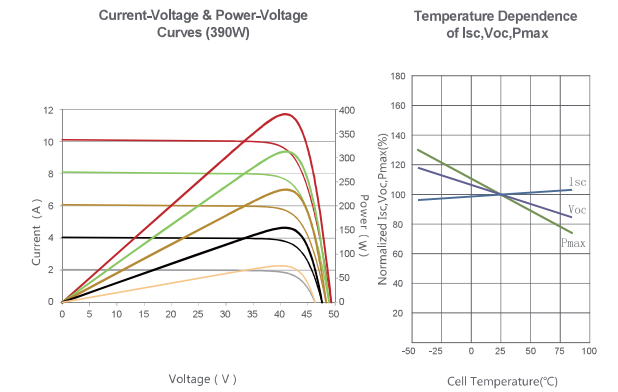

Mechanical Characteristics

Cell Type	Mono PERC Diamond Cell (158.75 x 158.75 mm)
No. of Half-cells	144 (6x24)
Dimensions	2008 x 1002 x 40mm (79.06 x 39.45 x 1.57 inch)
Weight	22.5 kg (49.6 lbs)
Front Glass	3.2mm, Anti-Reflection Coating, High Transmission, Low Iron, Tempered Glass
Frame	Anodized Aluminium Alloy
Junction Box	IP67 Rated
Output Cables	12 AWG, (+) 1400mm(55.12 in), (-) 1400mm(55.12 in) or Customized Length
Fire Type	Type 1

SPECIFICATIONS

Module Type	JKM390M-72HL-V		JKM395M-72HL-V		JKM400M-72HL-V		JKM405M-72HL-V		JKM410M-72HL-V	
	STC	NOCT	STC	NOCT	STC	NOCT	STC	NOCT	STC	NOCT
Maximum Power (Pmax)	390Wp	294Wp	395Wp	298Wp	400Wp	302Wp	405Wp	306Wp	410Wp	310Wp
Maximum Power Voltage (Vmp)	41.1V	39.1V	41.4V	39.3V	41.7V	39.6V	42.0V	39.8V	42.3V	40.0V
Maximum Power Current (Imp)	9.49A	7.54A	9.55A	7.60A	9.60A	7.66A	9.65A	7.72A	9.69A	7.76A
Open-circuit Voltage (Voc)	49.3V	48.0V	49.5V	48.2V	49.8V	48.5V	50.1V	48.7V	50.4V	48.9V
Short-circuit Current (Isc)	10.12A	8.02A	10.23A	8.09A	10.36A	8.16A	10.48A	8.22A	10.60A	8.26A
Module Efficiency STC (%)	19.38%		19.63%		19.88%		20.13%		20.38%	
Operating Temperature (°C)	-40°C~+85°C									
Maximum System Voltage	1500VDC(UL)/1500VDC(IEC)									
Maximum Series Fuse Rating	20A									
Power Tolerance	0~+3%									
Temperature Coefficients of Pmax	-0.36%/°C									
Temperature Coefficients of Voc	-0.28%/°C									
Temperature Coefficients of Isc	0.048%/°C									
Nominal Operating Cell Temperature (NOCT)	45±2°C									

STC: ☀ Irradiance 1000W/m² 📱 Cell Temperature 25°C ☁ AM=1.5

NOCT: ☀ Irradiance 800W/m² 📱 Ambient Temperature 20°C ☁ AM=1.5 🌀 Wind Speed 1m/s

* Power measurement tolerance: ± 3%

CAUTION: READ SAFETY AND INSTALLATION INSTRUCTIONS BEFORE USING THE PRODUCT.
© Jinko Solar Co., Ltd. All rights reserved. Specifications included in this datasheet are subject to change without notice.
JKM390-410M-72HL-V-A2-US



IQ8 Series Microinverters

Our newest IQ8 Microinverters are the industry's first microgrid-forming, software-defined microinverters with split-phase power conversion capability to convert DC power to AC power efficiently. The brain of the semiconductor-based microinverter is our proprietary application-specific integrated circuit (ASIC) which enables the microinverter to operate in grid-tied or off-grid modes. This chip is built in advanced 55nm technology with high speed digital logic and has super-fast response times to changing loads and grid events, alleviating constraints on battery sizing for home energy systems.



Part of the Enphase Energy System, IQ8 Series Microinverters integrate with the Enphase IQ Battery, Enphase IQ Gateway, and the Enphase App monitoring and analysis software.



IQ8 Series Microinverters redefine reliability standards with more than one million cumulative hours of power-on testing, enabling an industry-leading limited warranty of up to 25 years.



Connect PV modules quickly and easily to IQ8 Series Microinverters using the included Q-DCC-2 adapter cable with plug-n-play MC4 connectors.



IQ8 Series Microinverters are UL Listed as PV Rapid Shut Down Equipment and conform with various regulations, when installed according to manufacturer's instructions.

Easy to install

- Lightweight and compact with plug-n-play connectors
- Power Line Communication (PLC) between components
- Faster installation with simple two-wire cabling

High productivity and reliability

- Produce power even when the grid is down
- More than one million cumulative hours of testing
- Class II double-insulated enclosure
- Optimized for the latest high-powered PV modules

Microgrid-forming

- Complies with the latest advanced grid support
- Remote automatic updates for the latest grid requirements
- Configurable to support a wide range of grid profiles
- Meets CA Rule 21 (UL 1741-SA) requirements

IQ8 Series Microinverters

INPUT DATA (DC)		IQ8-60-2-US	IQ8PLUS-72-2-US	IQ8M-72-2-US	IQ8A-72-2-US	IQ8H-240-72-2-US	IQ8H-208-72-2-US ¹
Commonly used module pairings ²	W	235 – 350	235 – 440	260 – 460	295 – 500	320 – 540+	295 – 500+
Module compatibility		60-cell/120 half-cell		60-cell/120 half-cell and 72-cell/144 half-cell			
MPPT voltage range	V	27 – 37	29 – 45	33 – 45	36 – 45	38 – 45	38 – 45
Operating range	V	25 – 48		25 – 58			
Min/max start voltage	V	30 / 48		30 / 58			
Max input DC voltage	V	50		60			
Max DC current ³ [module Isc]	A			15			
Overvoltage class DC port				II			
DC port backfeed current	mA			0			
PV array configuration		1x1 Ungrounded array; No additional DC side protection required; AC side protection requires max 20A per branch circuit					
OUTPUT DATA (AC)		IQ8-60-2-US	IQ8PLUS-72-2-US	IQ8M-72-2-US	IQ8A-72-2-US	IQ8H-240-72-2-US	IQ8H-208-72-2-US
Peak output power	VA	245	300	330	366	384	366
Max continuous output power	VA	240	290	325	349	380	360
Nominal (L-L) voltage/range ⁴	V			240 / 211 – 264		208 / 183 – 250	
Max continuous output current	A	1.0	1.21	1.35	1.45	1.58	1.73
Nominal frequency	Hz	60					
Extended frequency range	Hz	50 – 68					
Max units per 20 A (L-L) branch circuit ⁵		16	13	11	11	10	9
Total harmonic distortion		<5%					
Overvoltage class AC port		III					
AC port backfeed current	mA	30					
Power factor setting		1.0					
Grid-tied power factor (adjustable)		0.85 leading – 0.85 lagging					
Peak efficiency	%	97.5	97.6	97.6	97.6	97.6	97.4
CEC weighted efficiency	%	97	97	97	97.5	97	97
Night-time power consumption	mW	60					
MECHANICAL DATA							
Ambient temperature range		-40°C to +60°C (-40°F to +140°F)					
Relative humidity range		4% to 100% (condensing)					
DC Connector type		MC4					
Dimensions (HxWxD)		212 mm (8.3") x 175 mm (6.9") x 30.2 mm (1.2")					
Weight		1.08 kg (2.38 lbs)					
Cooling		Natural convection – no fans					
Approved for wet locations		Yes					
Acoustic noise at 1 m		<60 dBA					
Pollution degree		PD3					
Enclosure		Class II double-insulated, corrosion resistant polymeric enclosure					
Environ. category / UV exposure rating		NEMA Type 6 / outdoor					
COMPLIANCE							
Certifications		CA Rule 21 (UL 1741-SA), UL 62109-1, UL1741/IEEE1547, FCC Part 15 Class B, ICES-0003 Class B, CAN/CSA-C22.2 NO. 107.1-01					
		This product is UL Listed as PV Rapid Shut Down Equipment and conforms with NEC 2014, NEC 2017, and NEC 2020 section 690.12 and C22.1-2018 Rule 64-218 Rapid Shutdown of PV Systems, for AC and DC conductors, when installed according to manufacturer's instructions.					

(1) The IQ8H-208 variant will be operating in grid-tied mode only at 208V AC. (2) No enforced DC/AC ratio. See the compatibility calculator at <https://link.enphase.com/module-compatibility> (3) Maximum continuous input DC current is 10.6A (4) Nominal voltage range can be extended beyond nominal if required by the utility. (5) Limits may vary. Refer to local requirements to define the number of microinverters per branch in your area.

Enphase IQ Combiner 4/4C

X-IQ-AM1-240-4
X-IQ-AM1-240-4C



The **Enphase IQ Combiner 4/4C** with Enphase IQ Gateway and integrated LTE-M1 cell modem (included only with IQ Combiner 4C) consolidates interconnection equipment into a single enclosure and streamlines IQ microinverters and storage installations by providing a consistent, pre-wired solution for residential applications. It offers up to four 2-pole input circuits and Eaton BR series busbar assembly.

Smart

- Includes IQ Gateway for communication and control
- Includes Enphase Mobile Connect cellular modem (CELLMODEM-M1-06-SP-05), included only with IQ Combiner 4C
- Includes solar shield to match Enphase IQ Battery aesthetics and deflect heat
- Flexible networking supports Wi-Fi, Ethernet, or cellular
- Optional AC receptacle available for PLC bridge
- Provides production metering and consumption monitoring

Simple

- Centered mounting brackets support single stud mounting
- Supports bottom, back and side conduit entry
- Up to four 2-pole branch circuits for 240 VAC plug-in breakers (not included)
- 80A total PV or storage branch circuits

Reliable

- Durable NRTL-certified NEMA type 3R enclosure
- Five-year limited warranty
- Two years labor reimbursement program coverage included for both the IQ Combiner SKU's
- UL listed



To learn more about Enphase offerings, visit enphase.com



Enphase IQ Combiner 4/4C

MODEL NUMBER	
IQ Combiner 4 (X-IQ-AM1-240-4)	IQ Combiner 4 with Enphase IQ Gateway printed circuit board for integrated revenue grade PV production metering (ANSI C12.20 +/- 0.5%) and consumption monitoring (+/- 2.5%). Includes a silver solar shield to match the IQ Battery system and IQ System Controller 2 and to deflect heat.
IQ Combiner 4C (X-IQ-AM1-240-4C)	IQ Combiner 4C with Enphase IQ Gateway printed circuit board for integrated revenue grade PV production metering (ANSI C12.20 +/- 0.5%) and consumption monitoring (+/- 2.5%). Includes Enphase Mobile Connect cellular modem (CELLMODEM-M1-06-SP-05), a plug-and-play industrial-grade cell modem for systems up to 60 microinverters. (Available in the US, Canada, Mexico, Puerto Rico, and the US Virgin Islands, where there is adequate cellular service in the installation area.) Includes a silver solar shield to match the IQ Battery and IQ System Controller and to deflect heat.
ACCESSORIES AND REPLACEMENT PARTS (not included, order separately)	
Ensemble Communications Kit COMMS-CELLMODEM-M1-06 CELLMODEM-M1-06-SP-05 CELLMODEM-M1-06-AT-05	- Includes COMMS-KIT-01 and CELLMODEM-M1-06-SP-05 with 5-year Sprint data plan for Ensemble sites - 4G based LTE-M1 cellular modem with 5-year Sprint data plan - 4G based LTE-M1 cellular modem with 5-year AT&T data plan
Circuit Breakers BRK-10A-2-240V BRK-15A-2-240V BRK-20A-2P-240V BRK-15A-2P-240V-B BRK-20A-2P-240V-B	Supports Eaton BR210, BR215, BR220, BR230, BR240, BR250, and BR260 circuit breakers. Circuit breaker, 2 pole, 10A, Eaton BR210 Circuit breaker, 2 pole, 15A, Eaton BR215 Circuit breaker, 2 pole, 20A, Eaton BR220 Circuit breaker, 2 pole, 15A, Eaton BR215B with hold down kit support Circuit breaker, 2 pole, 20A, Eaton BR220B with hold down kit support
EPLC-01	Power line carrier (communication bridge pair), quantity - one pair
XA-SOLARSHIELD-ES	Replacement solar shield for IQ Combiner 4/4C
XA-PLUG-120-3	Accessory receptacle for Power Line Carrier in IQ Combiner 4/4C (required for EPLC-01)
XA-ENV-PCBA-3	Replacement IQ Gateway printed circuit board (PCB) for Combiner 4/4C
X-IQ-NA-HD-125A	Hold down kit for Eaton circuit breaker with screws.
ELECTRICAL SPECIFICATIONS	
Rating	Continuous duty
System voltage	120/240 VAC, 60 Hz
Eaton BR series busbar rating	125 A
Max. continuous current rating	65 A
Max. continuous current rating (input from PV/storage)	64 A
Max. fuse/circuit rating (output)	90 A
Branch circuits (solar and/or storage)	Up to four 2-pole Eaton BR series Distributed Generation (DG) breakers only (not included)
Max. total branch circuit breaker rating (input)	80A of distributed generation / 95A with IQ Gateway breaker included
Envoy breaker	10A or 15A rating GE/Siemens/Eaton included
Production metering CT	200 A solid core pre-installed and wired to IQ Gateway
Consumption monitoring CT (CT-200-SPLIT)	A pair of 200 A split core current transformers
MECHANICAL DATA	
Dimensions (WxHxD)	37.5 x 49.5 x 16.8 cm (14.75" x 19.5" x 6.63"). Height is 21.06" (53.5 cm) with mounting brackets.
Weight	7.5 kg (16.5 lbs)
Ambient temperature range	-40° C to +46° C (-40° to 115° F)
Cooling	Natural convection, plus heat shield
Enclosure environmental rating	Outdoor, NRTL-certified, NEMA type 3R, polycarbonate construction
Wire sizes	• 20 A to 50 A breaker inputs: 14 to 4 AWG copper conductors • 60 A breaker branch input: 4 to 1/0 AWG copper conductors • Main lug combined output: 10 to 2/0 AWG copper conductors • Neutral and ground: 14 to 1/0 copper conductors Always follow local code requirements for conductor sizing.
Altitude	To 2000 meters (6,560 feet)
INTERNET CONNECTION OPTIONS	
Integrated Wi-Fi	802.11b/g/n
Cellular	CELLMODEM-M1-06-SP-05, CELLMODEM-M1-06-AT-05 (4G based LTE-M1 cellular modem). Note that an Enphase Mobile Connect cellular modem is required for all Ensemble installations.
Ethernet	Optional, 802.3, Cat5E (or Cat 6) UTP Ethernet cable (not included)
COMPLIANCE	
Compliance, IQ Combiner	UL 1741, CAN/CSA C22.2 No. 107.1, 47 CFR, Part 15, Class B, ICES 003 Production metering: ANSI C12.20 accuracy class 0.5 (PV production) Consumption metering: accuracy class 2.5
Compliance, IQ Gateway	UL 60601-1/CANCSA 22.2 No. 61010-1

To learn more about Enphase offerings, visit enphase.com

© 2022 Enphase Energy. All rights reserved. Enphase, the Enphase logo, IQ Combiner 4/4C, and other names are trademarks of Enphase Energy, Inc. Data subject to change. 02-14-2022



Ultra Rail

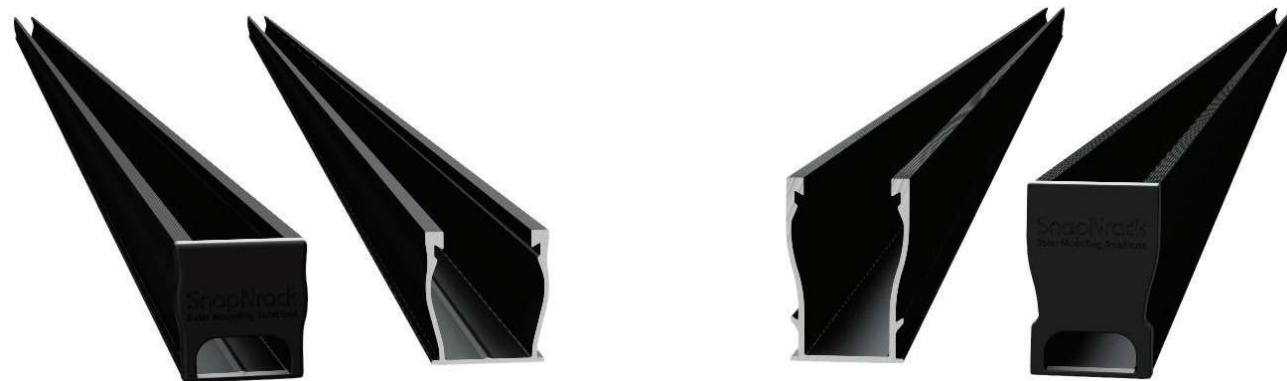

The Ultimate Value in Rooftop Solar

 Industry leading Wire Management Solutions

 Mounts available for all roof types

 Single Tool Installation

 All SnapNrack Module Clamps & Accessories are compatible with both rail profiles

Start Installing Ultra Rail Today

RESOURCES
DESIGN
WHERE TO BUY

snapnrack.com/resources
snapnrack.com/configurator
snapnrack.com/where-to-buy

SnapNrack Ultra Rail System

A sleek, straightforward rail solution for mounting solar modules on all roof types. Ultra Rail features two rail profiles; UR-40 is a lightweight rail profile that is suitable for most geographic regions and maintains all the great features of SnapNrack rail, while UR-60 is a heavier duty rail profile that provides a larger rail channel and increased span capabilities. Both are compatible with all existing mounts, module clamps, and accessories for ease of install.

The Entire System is a Snap to Install

- New Ultra Rail Mounts include snap-in brackets for attaching rail
- Compatible with all the SnapNrack Mid Clamps and End Clamps customers love
- Universal End Clamps and snap-in End Caps provide a clean look to the array edge

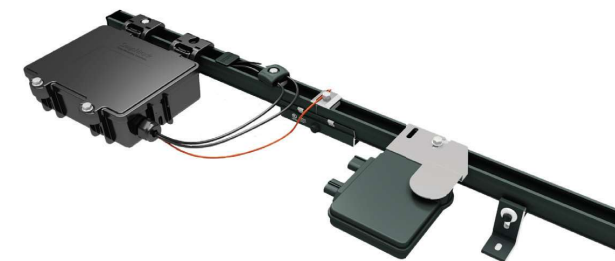

Unparalleled Wire Management

- Open rail channel provides room for running wires resulting in a long-lasting quality install
- Industry best wire management offering includes Junction Boxes, Universal Wire Clamps, MLPE Attachment Kits, and Conduit Clamps
- System is fully bonded and listed to UL 2703 Standard

Heavy Duty UR-60 Rail

- UR-60 rail profile provides increased span capabilities for high wind speeds and snow loads
- Taller, stronger rail profile includes profile-specific rail splice and end cap
- All existing mounts, module clamps, and accessories are retained for the same great install experience



Quality. Innovative. Superior.

SnapNrack Solar Mounting Solutions are engineered to optimize material use and labor resources and improve overall installation quality and safety.

877-732-2860

www.snapnrack.com

contact@snapnrack.com

© 2019 by SnapNrack Solar Mounting Solutions. All rights reserved.

FLASHKIT PRO



FLASHKIT PRO is the complete attachment solution for composition shingle roofs. Featuring Unirac's patented SHED & SEAL technology, a weather proof system which provides the ultimate protection against roof leaks. Kitted in 10 packs for maximum convenience, flashings and hardware are available in Mill or Dark finishes. With FLASHKIT pro, you have everything you need for a quick, professional installation.



TRUSTED WATER SEAL FLASHINGS
FEATURING SHED & SEAL TECHNOLOGY



YOUR COMPLETE SOLUTION
Flashings, lags, continuous slot L-Feet and hardware



CONVENIENT 10 PACKS
Packaged for speed and ease of handling

FLASHKIT PRO

INSTALLATION GUIDE



FLASHKIT PRO IS THE COMPLETE FLASHING AND ATTACHMENT SOLUTION FOR COMPOSITION ROOFS.



STEP 1
INSTALL FLASHKIT PRO FLASHING



STEP 2
INSTALL L-FOOT



STEP 3
ATTACH L-FOOT TO RAIL

PRE-INSTALL

- Locate roof rafters and snap chalk lines to mark the installation point for each roof attachment.
- Drill a 7/32" pilot hole at each roof attachment. Fill each pilot hole with sealant.

STEP 1 INSTALL FLASHKIT PRO FLASHING

- Add a U-shaped bead of roof sealant to the underside of the flashing with the open side of the U pointing down the roof slope. Slide the aluminum flashing underneath the row of shingles directly up slope from the pilot hole as shown. Align the indicator marks on the lower end of the flashing with the chalk lines on the roof to center the raised hole in the flashing over the pilot hole in the roof. When installed correctly, the flashing will extend under the two courses of shingles above the pilot hole.

STEP 2 INSTALL L-FOOT

- Fasten L-foot and Flashing into place by passing the included lag bolt and pre-installed stainless steel-backed EPDM washer through the L-foot EPDM grommet, and the raised hole in the flashing, into the pilot hole in the roof rafter.

- Drive the lag bolt down until the L-foot is held firmly in place. It is normal for the EPDM on the underside of the stainless steel backed EPDM washer to compress and expand beyond the outside edge of the steel washer when the proper torque is applied.

TIP:

- Use caution to avoid over-torquing the lag bolt if using an impact driver.
- Repeat Steps 1 and 2 at each roof attachment point.

STEP 3 ATTACH L-FOOT TO RAIL

- Insert the included 3/8" -16 T-bolts into the lower slot on the Rail (sold separately), spacing the bolts to match the spacing between the roof attachments.
- Position the Rail against the L-Foot and insert the threaded end of the T-Bolt through the continuous slot in the L-Foot. Apply anti-seize to bolt threads to prevent galling of the T-bolt and included 3/8" serrated flange nut. Place the 3/8" flange nut on the T-bolt and finger tighten. Repeat STEP 3 until all L-Feet are secured to the Rail with a T-bolt. Adjust the level and height of the Rail and torque each bolt to 30ft-lbs.

FASTER INSTALLATION. 25-YEAR WARRANTY.

FOR QUESTIONS OR CUSTOMER SERVICE VISIT UNIRAC.COM OR CALL (505) 248-2702

THE COMPLETE ROOF ATTACHMENT SOLUTION

FOR QUESTIONS OR CUSTOMER SERVICE VISIT UNIRAC.COM OR CALL (505) 248-2702