

VICINITY MAP

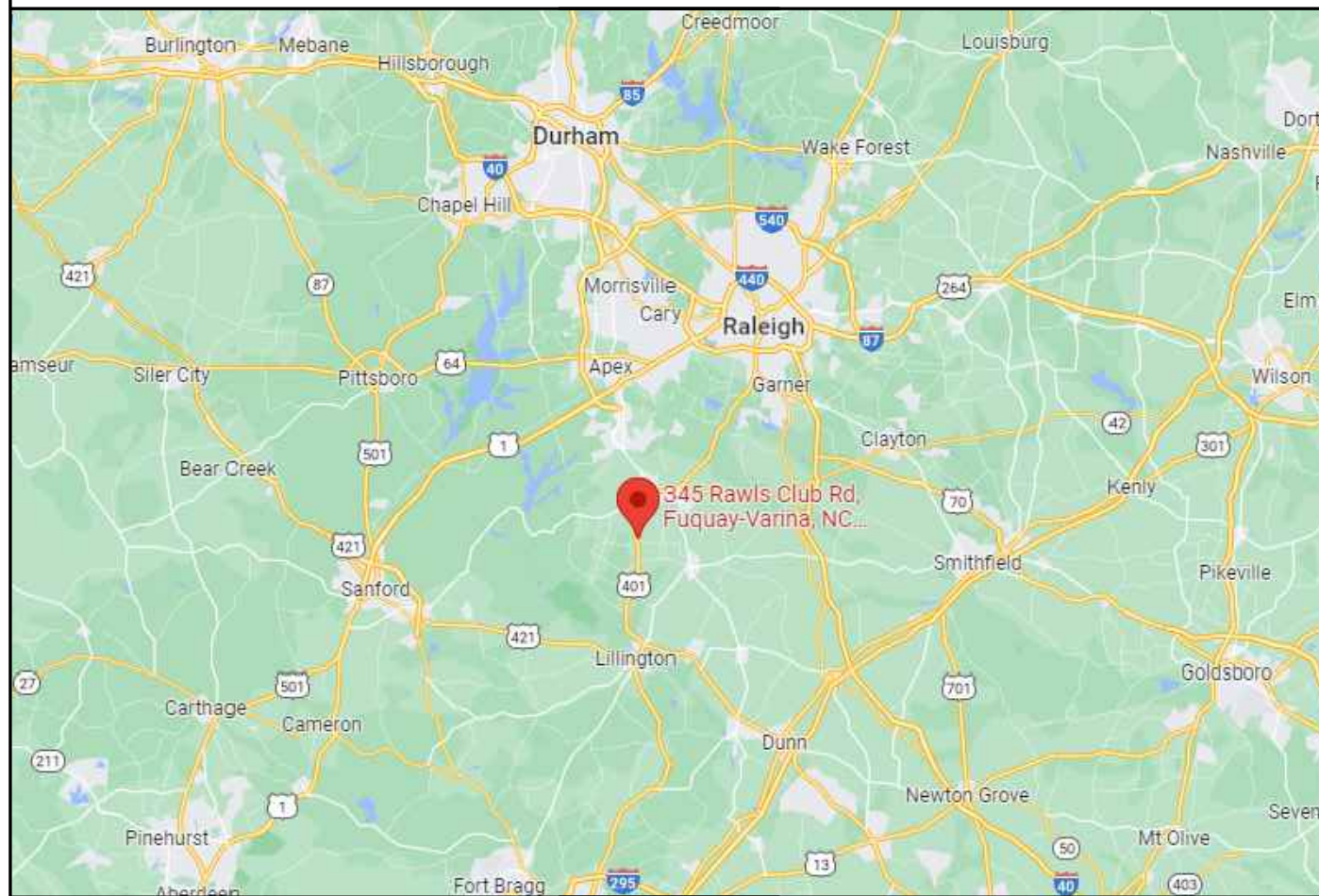

PROPERTY MAP



ENGINEER:



MODEL ENERGY

300 FAYETTEVILLE ST.
#1430
RALEIGH, NC 27602
919-274-9905
MODELENERGY.COM
P-1194

JOB TITLE:

NEW SOLAR PV SYSTEM
29.20 kW DC INPUT
20.00 kW AC EXPORT

Jennifer Zemo
345 Rawls Club Rd,
Fuquay-Varina, NC 27526

CLIENT:

READY SOLAR

ISSUED FOR:	DATE:
CONSTRUCTION	V1-07/20/22
	V2-10/27/22

PROJECT INFORMATION

PV1.1

CONSTRUCTION NOTES

- ALL WORK AND EQUIPMENT SHALL BE INSTALLED IN ACCORDANCE WITH THE LATEST NATIONAL, STATE, AND LOCAL CODES AND ORDINANCES
- FOLLOW MANUFACTURER'S INSTALLATION INSTRUCTIONS, BEST PRACTICES, AND SPECIFICATIONS
- WIRES SHALL BE RATED AND LABELED "SUNLIGHT RESISTANT" WHERE EXPOSED TO AMBIENT CONDITIONS
- THE PHOTOVOLTAIC SYSTEM SHALL NOT EXCEED 600 VOLTS OR 800 AMPS
- EACH ELECTRICAL APPLIANCE SHALL BE PROVIDED WITH A NAMEPLATE GIVING THE IDENTIFYING NAME AND THE RATING IN VOLTS AND AMPERES, OR VOLTS AND WATTS. IF THE APPLIANCE IS TO BE USED ON A SPECIFIC FREQUENCY OR FREQUENCIES, IT SHALL BE SO MARKED. WHERE MOTOR OVERLOAD PROTECTION EXTERNAL TO THE APPLIANCES IS REQUIRED, THE APPLIANCE SHALL BE SO MARKED
- WHERE APPLICABLE, GROUNDING ELECTRODE CONDUCTOR TO BE CONTINUOUS. GROUNDING CRIMPS TO BE IRREVERSIBLE
- IN ONE- AND TWO-FAMILY DWELLINGS, LIVE PARTS IN PHOTOVOLTAIC SOURCE CIRCUITS AND PHOTOVOLTAIC OUTPUT CIRCUITS OVER 150 VOLTS TO GROUND, SHALL ONLY BE ACCESSIBLE TO QUALIFIED PERSONS WHILE ENERGIZED.
- PHOTOVOLTAIC SYSTEMS SHALL BE PERMANENTLY MARKED AT VARIOUS EQUIPMENT LOCATIONS TO IDENTIFY THAT A PHOTOVOLTAIC SYSTEM IS INSTALLED AND THAT VARIOUS DANGERS ARE PRESENT.
- EACH PHOTOVOLTAIC SYSTEM DISCONNECTING MEANS SHALL BE PERMANENTLY MARKED TO IDENTIFY IT AS A PHOTOVOLTAIC SYSTEM DISCONNECT
- WHERE ALL TERMINALS OF A DISCONNECTING MEANS MAY BE ENERGIZED IN THE OPEN POSITION, A WARNING SIGN SHALL BE MOUNTED ON OR ADJACENT TO THE DISCONNECT
- A PERMANENT LABEL FOR THE DIRECT-CURRENT PHOTOVOLTAIC POWER SOURCE SHALL BE PROVIDED BY THE INSTALLED AT THE DC DISCONNECT MEANS
- A PERMANENT PLAQUE OR DIRECTORY, DENOTING ALL ELECTRIC POWER SOURCES SERVING THE PREMISES, SHALL BE INSTALLED AT EACH SERVICE EQUIPMENT LOCATION AND AT LOCATIONS OF ALL POWER PRODUCTION SOURCES.
- A PERMANENT PLAQUE OR DIRECTORY SHALL BE PROVIDED DENOTING THE LOCATIONS OF THE SERVICE DISCONNECT MEANS AND THE PHOTOVOLTAIC SYSTEM DISCONNECT MEANS IF THEY ARE NOT LOCATED AT THE SAME LOCATION.
- ALL MODULE GROUND CONNECTIONS SHALL BE MADE IN ACCORDANCE WITH NEC SECTION 690.4 (C)



REVISED

ABBREVIATIONS

A	AMPERE
AC	ALTERNATING CURRENT
DC	DIRECT CURRENT
EGC	EQUIPMENT GROUNDING CONDUCTOR
EMT	ELECTRICAL METAL TUBING
GALV	GALVANIZED
GEC	GROUNDING ELECTRODE CONDUCTOR
GND	GROUND
I	CURRENT
IMP	CURRENT AT MAXIMUM POWER
ISC	SHORT-CIRCUIT CURRENT
kVA	KILOVOLT AMPERE
kW	KILOWATT
MAX	MAXIMUM
MIN	MINIMUM
MCB	MAIN CIRCUIT BREAKER
MLO	MAIN LUG ONLY
NOM	NOMINAL
NTS	NOT TO SCALE
PnOM	NOMINAL POWER
PV	PHOTOVOLTAIC
PVC	POLYVINYL CHLORIDE
SN	SOLAR NOON
STC	STANDARD TEST CONDITIONS
TYP	TYPICAL
V	VOLT
VMP	VOLTAGE AT MAXIMUM POWER
Voc	OPEN-CIRCUIT VOLTAGE
W	WATT

CODE REFERENCES

2017 NATIONAL ELECTRIC CODE
2018 NORTH CAROLINA BUILDING CODE
2018 NORTH CAROLINA RESIDENTIAL CODE
2018 NORTH CAROLINA FIRE CODE

SHEET INDEX

PV1.1 PROJECT INFORMATION
PV2.1 SITE INFORMATION
PV3.1 - 3.2 STRUCTURAL INFORMATION
PV4.1 - 4.2 ELECTRICAL INFORMATION
PV5.1 - 5.3 LABELS, DETAILS & SPECS

UTILITY COMPANY

DUKE ENERGY PROGRESS

SITE CONDITIONS

ASCE 7-10 WIND SPEED - 116 MPH
EXPOSURE CATEGORY - B
RISK CATEGORY - II

LEGEND

	DISCONNECT SWITCH
	FUSE
	CIRCUIT BREAKER
	EQUIP. GROUND

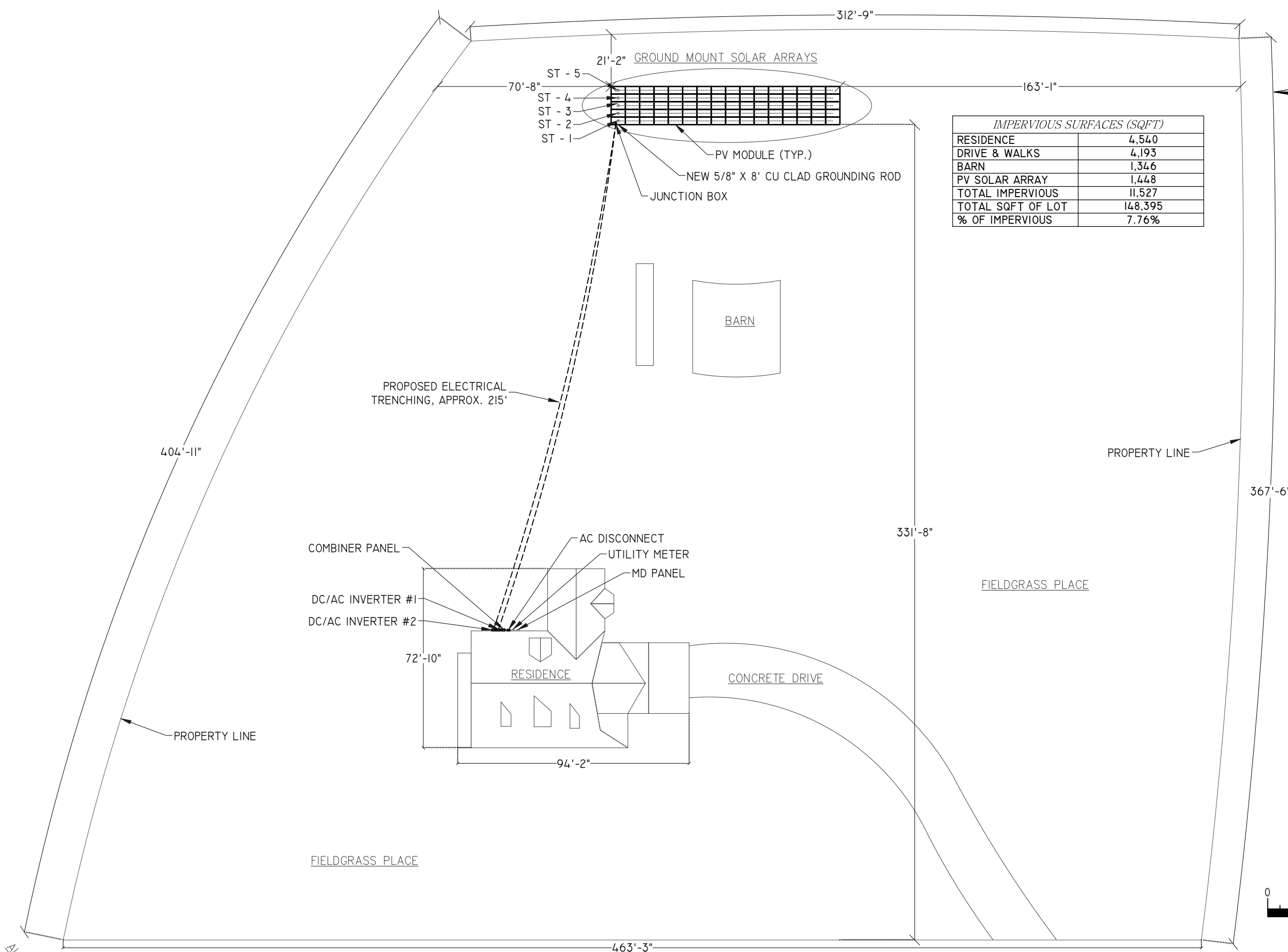

IMPERVIOUS SURFACES (SQFT)	
RESIDENCE	4,540
DRIVE & WALKS	4,193
BARN	1,346
PV SOLAR ARRAY	1,448
TOTAL IMPERVIOUS	11,527
TOTAL SQFT OF LOT	148,395
% OF IMPERVIOUS	7.76%

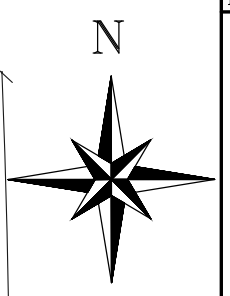

ENGINEER:

MODEL ENERGY
 300 FAYETTEVILLE ST.
 #1430
 RALEIGH, NC 27602
 919-274-9905
 MODELENERGY.COM
 P-1194

JOB TITLE:

NEW SOLAR PV SYSTEM
 29.20 kW DC INPUT
 20.00 kW AC EXPORT

Jennifer Zemo
 345 Rawls Club Rd,
 Fuquay-Varina, NC 27526

CLIENT:

READY SOLAR

ISSUED FOR:	DATE:
CONSTRUCTION	V1-07/20/22
	V2-10/27/22

SITE INFORMATION

PV2.1

1 SITE PLAN
 SCALE: 1" = 40'

345 RAWLS CLUB RD,
 FUQUAY-VARINA, NC 27526

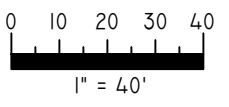

© 2022 MODEL ENERGY, PLLC EXPRESSLY RESERVES ITS COMMON LAW COPYRIGHT AND OTHER PROPERTY RIGHTS IN THESE PLANS. THESE PLANS ARE NOT TO BE REPRODUCED, CHANGED OR COPIED IN ANY FORM OR MANNER WHATSOEVER, NOR ARE THEY TO BE ASSIGNED TO ANY THIRD PARTY WITHOUT FIRST OBTAINING THE EXPRESSED WRITTEN PERMISSION AND CONSENT OF MODEL ENERGY, PLLC.

345 Rawls Club Road (#1056617)
ground based

IRONRIDGE
28357 INDUSTRIAL BLVD., HAYWARD, CA 94545

Project Details

Name	345 Rawls Club Road	Date	10/27/2022
Location	345 Rawls Club Road, Fuquay-Varina, NC 27526	ASCE code	7.10
Total modules	80	Wind speed	110 mph
Module	URE: FAM365E7G-BB (35mm)	Snow load	10 psf
Dimensions	Dimensions: 69.37" x 41.26" x 1.38" (1762.0mm x 1048.0mm x 35.0mm)	Wind exposure	B
Total watts	29,200 kW	Piers	16

Substructure & Foundation

Tilt	25°	South facing grade	20°
Pipe/tubing diameter	3"	Soil class	2 - 5
Foundation type	Ground screws	Screw length	63"
Freeze thaw depth	None entered	Hex head set screws / Screw	4

345 Rawls Club Road (#1056617)
ground based

IRONRIDGE
28357 INDUSTRIAL BLVD., HAYWARD, CA 94545

Pipe Fitting Detail

XR1000 Rail

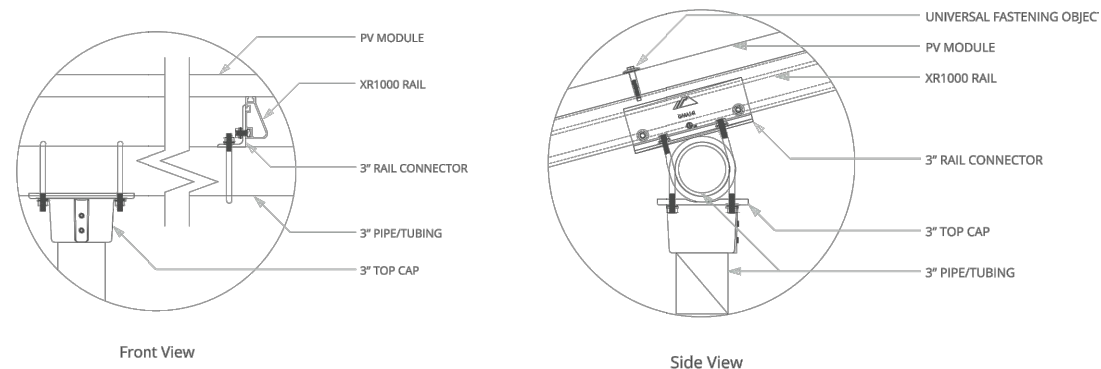

Clamp Detail

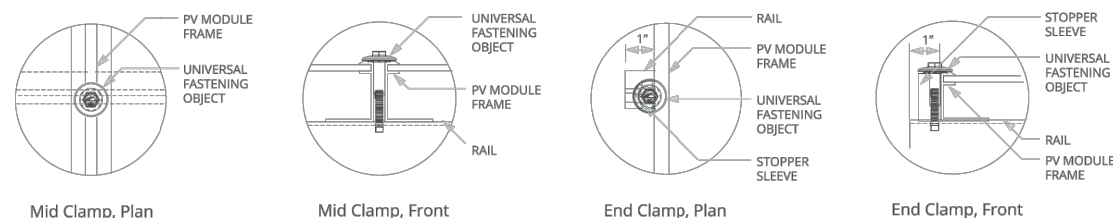

1 GROUND MOUNT DETAILS
SCALE: NTS

345 Rawls Club Road (#1056617)
ground based

IRONRIDGE
28357 INDUSTRIAL BLVD., HAYWARD, CA 94545

Sub array #1

Rows	5	Columns	16	# Arrays	1
Area	93' (EW) x 17' 6" (NS)	Rail type	XR1000	Diagonal bracing	no
E/W spacing	12' 3"	Rail cantilever	3' 9"	Pipe cantilever	3' 7"
Piers/array	16	Total south piers	8 (3' 11")	Total north piers	8 (4' 10")
Total cross pipes	2 (93')	Total pipe length	256' 4"		
Shear	1,138 lbs	Moment	2,845 ft-lbs	Uplift	-1,400 lbs

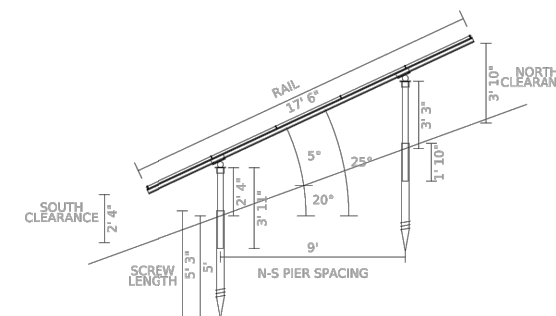
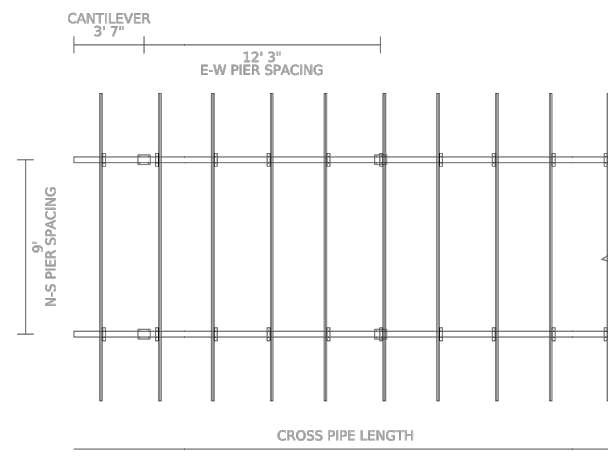

Last updated by Kevin Ochoa on 10/27/22 10:13 AM

Page 2 of 5

NOTE:

THE STRUCTURAL INFORMATION CONTAINED IN THE PLANS ON THIS SHEET WAS NOT PRODUCED OR VALIDATED BY MODEL ENERGY, PLLC. IT IS SHOWN AS PART OF THESE CONSTRUCTION DOCUMENTS FOR PERMITTING PURPOSES ONLY.

ENGINEER:

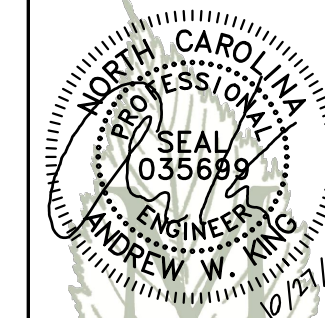

MODEL ENERGY

300 FAYETTEVILLE ST.
#1430
RALEIGH, NC 27602
919-274-9905
MODELENERGY.COM
P-1194

JOB TITLE:

NEW SOLAR PV SYSTEM
29.20 kW DC INPUT
20.00 kW AC EXPORT

Jennifer Zemo
345 Rawls Club Rd,
Fuquay-Varina, NC 27526

CLIENT:

READY SOLAR

ISSUED FOR:	DATE:
CONSTRUCTION	V1-07/20/22
	V2-10/27/22

STRUCTURAL INFORMATION

PV3.1

© 2022 MODEL ENERGY, PLLC EXPRESSLY RESERVES ITS COMMON LAW COPYRIGHT AND OTHER PROPERTY RIGHTS IN THESE PLANS. THESE PLANS ARE NOT TO BE REPRODUCED, CHANGED OR COPIED IN ANY FORM OR MANNER WHATSOEVER, NOR ARE THEY TO BE ASSIGNED TO ANY THIRD PARTY WITHOUT FIRST OBTAINING THE EXPRESSED WRITTEN PERMISSION AND CONSENT OF MODEL ENERGY, PLLC.

Grounding Diagram

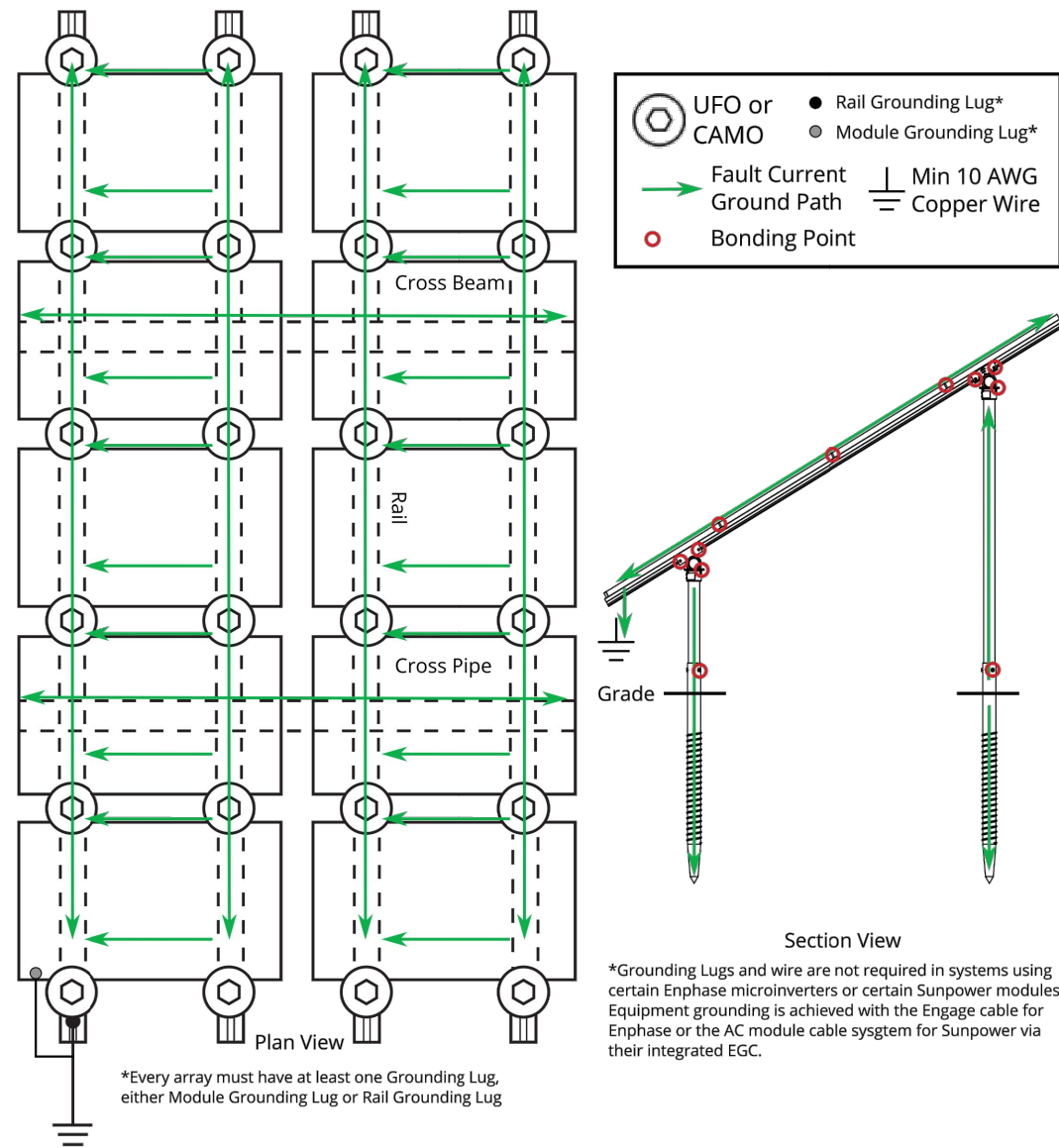

Bill of Materials

Part	Spares	Total Qty
Rails		
XR-1000-210A XR1000, Rail 210" (17.5 feet) Clear * [Custom Length] Please check with your distributor for availability.	0	32
Clamps & Grounding		
UFO-CL-01-A1 Universal Module Clamp, Clear	0	192
UFO-STP-35MM-M1 Stopper Sleeve, 35MM, Mill	0	64
XR-LUG-03-A1 Grounding Lug, Low Profile	0	1
Substructure		
70-0300-SGA SGA Top Cap at 3"	0	16
GM-BRC-003 Ground Mount Bonded Rail Connector - 3"	0	64
GM-HSHW-01-M1 Hex Head Set Screw	0	64

NOTE:

THE STRUCTURAL INFORMATION CONTAINED IN THE PLANS ON THIS SHEET WAS NOT PRODUCED OR VALIDATED BY MODEL ENERGY, PLLC. IT IS SHOWN AS PART OF THESE CONSTRUCTION DOCUMENTS FOR PERMITTING PURPOSES ONLY.

2 GROUND MOUNT DETAILS
SCALE: NTS

ENGINEER:



MODEL ENERGY

300 FAYETTEVILLE ST.
#1430
RALEIGH, NC 27602
919-274-9905
MODELENERGY.COM
P-1194

JOB TITLE:

NEW SOLAR PV SYSTEM
29.20 kW DC INPUT
20.00 kW AC EXPORT

Jennifer Zemo
345 Rawls Club Rd,
Fuquay-Varina, NC 27526

CLIENT:

READY SOLAR

ISSUED FOR:	DATE:
CONSTRUCTION	V1-07/20/22
	V2-10/27/22

STRUCTURAL
INFORMATION

PV3.2

CONDUCTOR SCHEDULE													
TAG	CURRENT CARRYING CONDUCTORS				GROUNDING CONDUCTORS				CONDUIT/RACEWAY				NOTES
	QTY.	SIZE	MATERIAL	INSULATION	QTY.	SIZE	MATERIAL	INSULATION	QTY.	SIZE	MATERIAL	LOCATION	
C1	2	10 AWG	COPPER	PV WIRE	1	6 AWG	COPPER	PV WIRE	-	-	-	FREE AIR	1
C2	10	10 AWG	COPPER	THWN-2	1	10 AWG	COPPER	THWN-2	1	1"	PVC 40	BURIED	2,4,7
C3	3	6 AWG	COPPER	THWN	1	10 AWG	COPPER	THWN	1	1"	NOTE 5	EXTERIOR	2,4,5
C4	3	2 AWG	COPPER	THWN	1	6 AWG	COPPER	THWN	1	1-1/4"	NOTE 5	EXTERIOR	2,4,5
C5	3	2 AWG	COPPER	THWN	-	-	-	-	1	1-1/4"	NOTE 5	EXTERIOR	2,4,5,6
XC	-	-	-	-	-	-	-	-	-	-	-	-	3

NOTES:

1. MANUFACTURER PROVIDED, UL LISTED WIRING HARNESS FOR USE ON EXPOSED ROOFS
2. CONDUIT SIZE SHOWN IS CODE MINIMUM. LARGER SIZES ARE ALLOWED.
3. EXISTING CONDUCTORS, FIELD VERIFY
4. EQUIPMENT TERMINAL RATING SHALL BE A MINIMUM OF 75°C AT BOTH END OF CONDUCTOR
5. PVC, EMT, ROMEX, LFNMC & FMC ARE ACCEPTABLE WHEN USED IN ACCORDANCE WITH ARTICLES 330, 334, 348, 350, 352, 356, & 358 OF THE 2017 NEC
6. SERVICE CONDUCTORS SHALL NOT TRAVEL MORE THAN 5' INSIDE OF THE BUILDING AND MORE THAN 10' IN TOTAL.
7. BURY CONDUIT A MINIMUM OF 18" BELOW GRADE.

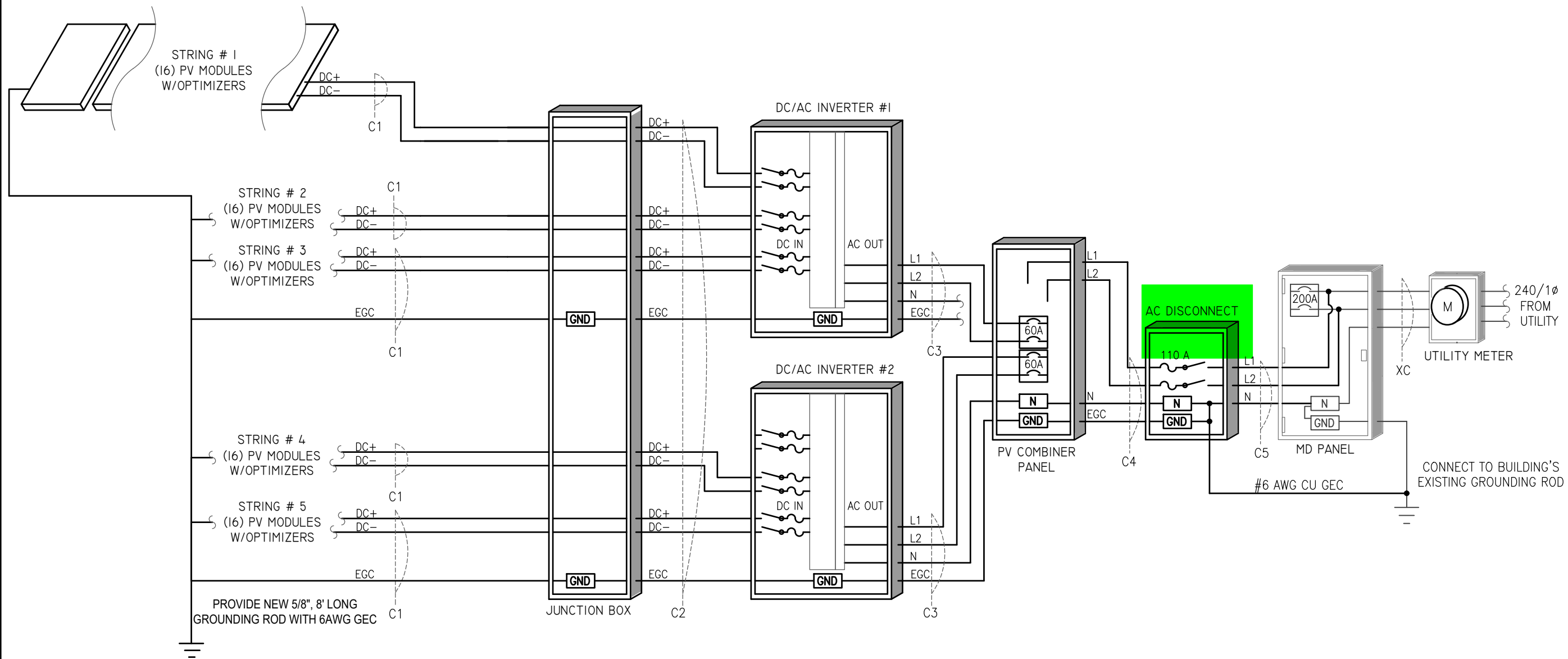

1 PV SYSTEM ELECTRICAL WIRING SCHEMATIC
SCALE: NTS

ENGINEER:

MODEL ENERGY
300 FAYETTEVILLE ST.
#1430
RALEIGH, NC 27602
919-274-9905
MODELENERGY.COM
P-1194

JOB TITLE:

NEW SOLAR PV SYSTEM
29.20 kW DC INPUT
20.00 kW AC EXPORT

Jennifer Zemo
345 Rawls Club Rd,
Fuquay-Varina, NC 27526

CLIENT:

READY SOLAR

ISSUED FOR:	DATE:
CONSTRUCTION	V1-07/20/22
	V2-10/27/22

ELECTRICAL INFORMATION

PV4.1

© 2022 MODEL ENERGY, PLLC EXPRESSLY RESERVES ITS COMMON LAW COPYRIGHT AND OTHER PROPERTY RIGHTS IN THESE PLANS. THESE PLANS ARE NOT TO BE REPRODUCED, CHANGED OR COPIED IN ANY FORM OR MANNER WHATSOEVER, NOR ARE THEY TO BE ASSIGNED TO ANY THIRD PARTY WITHOUT FIRST OBTAINING THE EXPRESSED WRITTEN PERMISSION AND CONSENT OF MODEL ENERGY, PLLC.

DC/AC INVERTER #1 & #2	
MAKE	SOLAREEDGE
MODEL	SEI0000H-US
TECHNOLOGY	TRANS-LESS
DC INPUT:	
MAX. POWER	15500 WATTS
MAX. VOLT	480 VOLTS
NOM. VOLT.	400 VOLTS
MAX. CURRENT	27 AMPS
MAX. SCC	45 AMPS
STRINGS INPUTS	3 STRINGS
AC OUTPUT:	
RATED POWER	10000 WATTS
MAX. POWER	10000 WATTS
NOM. VOLT.	240 VOLTS
MAX. CURR.	42 AMPS
GFP (Y/N)	YES
RPP (Y/N)	YES
GFCI (Y/N)	YES
AFCI (Y/N)	YES
DC DISC. (Y/N)	YES
RAPID SHUTDOWN	AUTOMATIC
FUSE RATING	15 AMPS
PROTECT. RATING	NEMA 4X

MODULE OPTIMIZER	
MAKE	SOLAREEDGE
MODEL	P400
DC INPUT:	
RATED POWER	400 WATTS
VOLT. RANGE	8-80
MAX. SCC	10.1 AMPS
MAX. DC INPUT CURRENT	12.5 AMPS
DC OUTPUT:	
MAX. CURRENT	15 AMPS
MAX. VOLT.	60 VOLTS
MAX. SYSTEM VOLT.	1000 VOLTS
MIN. STRING	8 OPTIMIZERS
MAX. STRING	25 OPTIMIZERS
MAX. POWER	
INVERTERS: SE3000H-SE6000H	5700 WATTS
INVERTERS: SE7600H-SE11400H	6000 WATTS

PV MODULES	
MAKE	URECO
MODEL	FAM365E7G-BB
TECHNOLOGY	MONO-CRYST.
NOM. POWER (P _{NOM})	365 WATTS
NOM. VOLT. (V _{MP})	34.20 VOLTS
O.C. VOLT. (V _{OC})	40.70 VOLTS
MAX. SYS. VOLT.	1000 V (UL)
TEMP. COEF. (V _{Tc})	-0.27 %/°C
NOM. CURR. (I _{MP})	10.68 AMPS
S.C. CURR. (I _{sc})	11.43 AMPS
MAX. SERIES FUSE	20 AMPS

JUNCTION BOX	
MAKE	SOLADECK
MODEL	0783-3R
PRO. RATING	NEMA 3R
VOLT. RATING	600 VOLTS
AMP RATING	120 AMPS
UL LISTING	UL 50

NOTES:

- PROVIDE ADDITIONAL JUNCTION BOXED AS REQUIRED TO COMBINE MODULES ON DIFFERENT ARRAYS INTO A SINGLE STRING

PV COMBINER PANEL (NEW)	
MAKE	N/A
MODEL	N/A
ENCL. RATING	NEMA 3R
VOLT. RATING	240 VOLTS
BUS RATING	125 AMPS
UL LIST. (Y/N)	YES
MAIN BREAKER (Y/N)	NO
BREAKER RATING	N/A

NOTES:

- BACK-FEED SOLAR OUTPUT VIA (2) 60A BREAKERS AT THE OPPOSITE END OF THE BUS BAR FROM FEEDER LUGS.
- PROVIDE WITH PERMANENT LABEL THAT READS, "PV COMBINER PANEL. DO NOT ADD ADDITIONAL LOADS."

AC DISCONNECT	
MAKE	N/A
MODEL	N/A
ENCL. RATING	NEMA 3R
VOLT. RATING	240 VOLTS
AMP RATING	200 AMPS
UL LIST. (Y/N)	YES
FUSED (Y/N)	YES
FUSE RATING	110 AMPS

NOTES:

- LOAD-BREAK RATED
- VISIBLE OPEN
- LOCKABLE IN OPEN POSITION
- INSTALL ADJACENT TO METER
- DISCONNECT TO BE READILY ACCESSIBLE TO UTILITY COMPANY PERSONNEL AT ALL TIMES
- SERVICE RATED
- PROVIDE NEUTRAL/GROUND BONDING JUMPER

MD PANEL (EXISTING)	
MAKE	N/A
MODEL	N/A
ENCL. RATING	NEMA 3R
VOLT. RATING	240 VOLTS
BUS RATING	200 AMPS
UL LIST. (Y/N)	YES
MAIN BREAKER (Y/N)	YES
BREAKER RATING	200 AMPS

NOTES:

- BACK-FEED SOLAR OUTPUT VIA SUPPLY SIDE TAP INSIDE OF MD PANEL

ENGINEER:

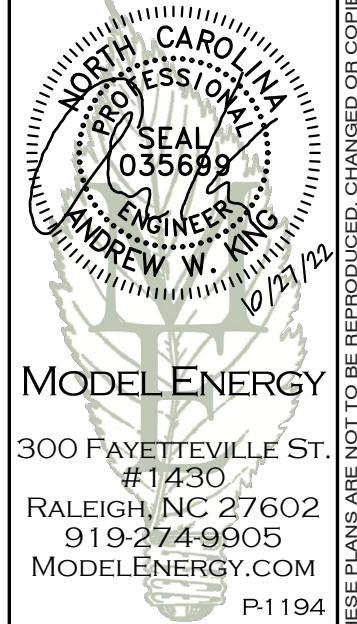

MODEL ENERGY

300 FAYETTEVILLE ST.
#1430
RALEIGH, NC 27602
919-274-9905
MODELENERGY.COM
P-1194

JOB TITLE:

NEW SOLAR PV SYSTEM
29.20 kW DC INPUT
20.00 kW AC EXPORT

Jennifer Zemo
345 Rawls Club Rd,
Fuquay-Varina, NC 27526

CLIENT:

READY SOLAR

ISSUED FOR:	DATE:
CONSTRUCTION	V1-07/20/22
	V2-10/27/22

ELECTRICAL INFORMATION

PV4.2



EN



EN



FAM_E7G-BB / 120 cells
345W - 365 W
Mono-Crystalline PV Module

URE Peach module uses URE state-of-the-art cell cutting technology, and advanced module manufacturing experiences.



Key Features

- Positive power tolerance +0 ~ +5 watt
- Withstand heavy loading front load 5400 Pa & rear load 2400 Pa
- Excellent low light performance 3.5% relative eff. Reduction at low (200W/m²)
- 100% EL inline inspection Better module reliability
- Design for 1000 VDC Reduce the system BOS effectively

DIRECT CURRENT PHOTOVOLTAIC POWER SOURCE

MAXIMUM VOLTAGE 600 VDC
MAX CIR. CURRENT 30 AMPS

NEC 690.53
PLACE ON ALL DC DISCONNECTING MEANS

Copyright © 2021 URE Corp. All rights reserved

For more information, please visit us at www.urecorp.com

Electrical Data

Model - STC		FAM345E7G-BB	FAM350E7G-BB	FAM355E7G-BB	FAM360E7G-BB	FAM365E7G-BB
Maximum Rating Power (Pmax)	[W]	345	350	355	360	365
Module Efficiency	[%]	18.68	18.95	19.22	19.50	19.77
Open Circuit Voltage (Voc)	[V]	39.90	40.10	40.30	40.50	40.70
Maximum Power Voltage	[V]	33.40	33.60	33.80	34.00	34.20
Short Circuit Current (Isc)	[A]	11.13	11.19	11.26	11.35	11.43
Maximum Power Current	[A]	10.33	10.42	10.51	10.59	10.68

*Standard Test Condition (STC): Cell Temperature 25 °C, Irradiance 1000 W/m², AM 1.5
*Values without tolerance are typical numbers. Measurement tolerance: ± 3%

Mechanical Data

Item	Specification
Dimensions	1762 mm (L) ¹ x 1048 mm (W) ¹ x 35 mm (D) ² / 69.37" (L) ¹ x 41.26" (W) ¹ x 1.38" (D) ²
Weight	19.6 kg / 43.21 lbs
Solar Cell	Mono / 83 mm x 166mm
Front Glass	White toughened safety glass, 3.2mm thickness
Frame	Black anodized aluminum profile
Junction Box	IP ≥67, 3 diodes
Connectors Type	MC4 Compatible
Cable	500mm (cable length can be customized), 4mm ²
Packaging Configuration	31 pcs Per Pallet, 806 pcs per 40' HQ container

¹: With assembly tolerance of ± 2 mm [± 0.08"]
²: With assembly tolerance of ± 0.8 mm [± 0.03"]

Operating Conditions

Item	Specification
Mechanical Load	5400 Pa
Maximum System Voltage	1000 VDC
Series Fuse Rating	20 A
Operating Temperature	-40 to 85 °C

Temperature Characteristics

Item	Specification
Nominal Module Operating Temperature	45 °C ± 2 °C
Temperature Coefficient of Isc	0.048 % / °C
Temperature Coefficient of Voc	-0.27 % / °C
Temperature Coefficient of Pmax	-0.35 % / °C

*Nominal module operating temperature (NMOT): Air mass AM 1.5, Irradiance 800W/m², temperature 20°C, wind speed 1 m/s.
*Reduction in efficiency from 1000W/m² to 200W/m² at 25°C: 3.5 ± 2%.

Engineering Drawing (mm)

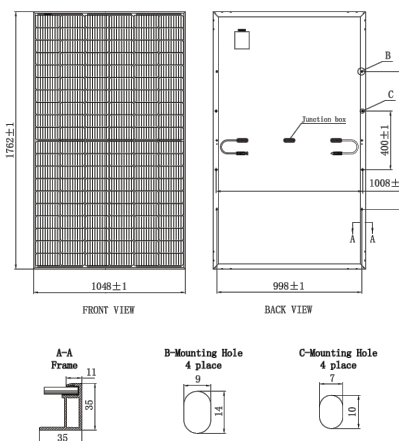

Dependence on Irradiance

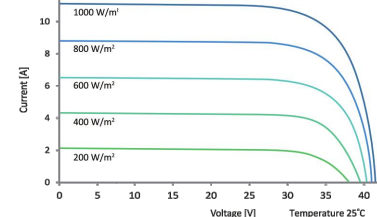

Reliability with Warranty

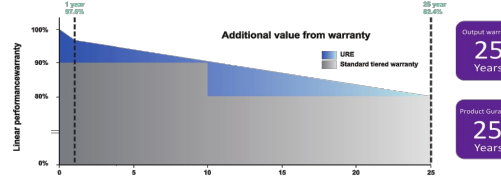

For more information, please visit us at www.urecorp.com

United Renewable Energy Co., Ltd.

Copyright © 2021 URE Corp. All rights reserved

Taipei Office

9F, NO. 295, Sec. 2, Tiding Blvd.,
Neihu Dist., Taipei 11493, Taiwan
Tel : +886-2-2656-2000
Fax : +886-2-2656-0593
e-mail : sales@urecorp.com

Headquarters

No. 7, Li-Hsin 3rd Road, Hsinchu Science Park
Hsinchu city 30078, Taiwan
Tel : +886-3-578-0011
Fax : +886-3-578-1255

URECO_US_Peach_FAM_E7G_V1_3.2_35mm_BS_EN_210520

ENGINEER:

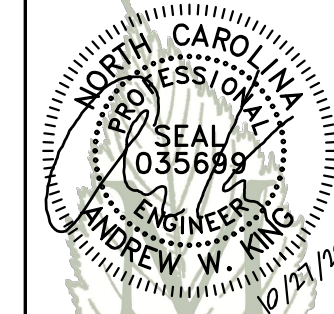

MODEL ENERGY

300 FAYETTEVILLE ST.
#1430
RALEIGH, NC 27602
919-274-9905
MODELENERGY.COM

P-1194

JOB TITLE:

NEW SOLAR PV SYSTEM
29.20 kW DC INPUT
20.00 kW AC EXPORT

Jennifer Zemo
345 Rawls Club Rd,
Fuquay-Varina, NC 27526

CLIENT:

READY SOLAR

ISSUED FOR: _____ DATE: _____
CONSTRUCTION V1-07/20/22
V2-10/27/22

LABELS, DETAILS & SPECS

PV5.1

WARNING: PHOTOVOLTAIC POWER SOURCE

NEC 690.31 (G)(3)&(4)
PLACE ON ALL JUNCTION BOXES, EXPOSED RACEWAYS, AND OTHER WIRING METHODS EVERY 10' AND ON EVERY SECTION SEPARATED BY ENCLOSURES, WALLS, PARTITIONS, CEILINGS, OR FLOORS.

RAPID SHUTDOWN SWITCH FOR SOLAR PV SYSTEM

NEC 690.56 (C)(3)
PLACE ON RAPID SHUTDOWN SWITCH OR EQUIPMENT WITH INTEGRATED RAPID SHUTDOWN *REFLECTIVE*

WARNING

FED BY MULTIPLE POWER SOURCES

TOTAL RATING OF ALL OVERCURRENT DEVICES EXCLUDING UTILITY OVERCURRENT DEVICE SHALL NOT EXCEED AMPACITY OF BUSBAR

NEC 705.12 (B)(2)(3)(c)
PLACE ADJACENT TO BACK-FED BREAKER

EQUIPMENT LABEL NOTES

- LABELS SHOWN ARE 1/2 THEIR ACTUAL REQUIRED SIZE.
- LABEL MATERIAL SHALL BE SUITABLE FOR THE EQUIPMENT ENVIRONMENT.
- CONDUIT SHALL BE MARKED WITH REQUIRED LABEL EVERY 10 FEET.

DIRECT CURRENT PHOTOVOLTAIC POWER SOURCE

MAXIMUM VOLTAGE 600 VDC
MAX CIR. CURRENT 45 AMPS

NEC 690.53
PLACE ON ALL DC DISCONNECTING MEANS

PHOTOVOLTAIC POWER SOURCE

OPERATING AC VOLT. 240 VAC
MAXIMUM OPERATING AC OUTPUT CURRENT 84 AMPS

NEC 690.54
PLACE ON INTERCONNECTION DISCONNECTING MEANS

SOLAR PV SYSTEM EQUIPPED WITH RAPID SHUTDOWN

TURN RAPID SHUTDOWN SWITCH TO THE "OFF" POSITION TO SHUT DOWN PV SYSTEM AND REDUCE SHOCK HAZARD IN THE ARRAY

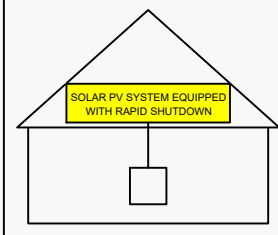

NEC 690.56 (C)(1)(a)
PLACE WITHIN 3FT OF SERVICE DISCONNECTING MEANS TO WHICH THE PV SYSTEMS ARE CONNECTED AND SHALL INDICATE THE LOCATIONS OF RAPID SHUTDOWN SWITCHES

PV SYSTEM DISCONNECT

NEC 690.13 (B)
PLACE ON PV SYSTEM DISCONNECTING MEANS.

WARNING

DUAL POWER SUPPLY

SOURCES: UTILITY GRID AND PV SOLAR ELECTRIC SYSTEM

NEC 705.12 (B)(3)
PLACE ON ALL EQUIPMENT THAT IS SUPPLIED BY BOTH POWER SOURCES

WARNING

ELECTRIC SHOCK HAZARD
TERMINALS ON THE LINE AND LOAD SIDES MAY BE ENERGIZED IN THE OPEN POSITION

NEC 690.13 (B)
PLACE ON PV SYSTEM DISCONNECTING MEANS.

WARNING

POWER SOURCE OUTPUT CONNECTION DO NOT RELOCATE THIS OVERCURRENT DEVICE

NEC 705.12 (B)(2)(3)(b)
PLACE ADJACENT TO BACK-FED BREAKER

© 2022 MODEL ENERGY, PLLC EXPRESSLY RESERVES ITS COMMON LAW COPYRIGHT AND OTHER PROPERTY RIGHTS IN THESE PLANS. THESE PLANS ARE NOT TO BE REPRODUCED, CHANGED OR COPIED IN ANY FORM OR MANNER WHATSOEVER, NOR ARE THEY TO BE ASSIGNED TO ANY THIRD PARTY WITHOUT FIRST OBTAINING THE EXPRESSED WRITTEN PERMISSION AND CONSENT OF MODEL ENERGY, PLLC.

Power Optimizer

For North America

P370 / P400 / P401 / P485 / P505



POWER OPTIMIZER

PV power optimization at the module level

- Specifically designed to work with SolarEdge inverters
- Up to 25% more energy
- Superior efficiency (99.5%)
- Mitigates all types of module mismatch losses, from manufacturing tolerance to partial shading
- Flexible system design for maximum space utilization
- Fast installation with a single bolt
- Next generation maintenance with module-level monitoring
- Meets NEC requirements for arc fault protection (AFCI) and Photovoltaic Rapid Shutdown System (PVRSS)
- Module-level voltage shutdown for installer and firefighter safety

solaredge.com



Power Optimizer

For North America

P370 / P400 / P401 / P485 / P505

Optimizer model (typical module compatibility)	P370 (for higher-power 60 and 72-cell modules)	P400 (for 72 & 96-cell modules)	P401 (for high power 60 and 72-cell modules)	P485 (for high-voltage modules)	P505 (for higher current modules)		
INPUT							
Rated Input DC Power ⁽¹⁾	370	400	430	485	505	W	
Absolute Maximum Input Voltage (Voc at lowest temperature)	60	80	60	125 ⁽²⁾	83 ⁽²⁾	Vdc	
MPPT Operating Range	8 - 60	8 - 80	8 - 60	12.5 - 105	12.5 - 83	Vdc	
Maximum Short Circuit Current (Isc)	11	10.1	12.5	11	14	Adc	
Maximum DC Input Current	13.75	12.5	14.65	12.5	17.5		
Maximum Efficiency						99.5	%
Weighted Efficiency						98.8	%
Overvoltage Category						II	
OUTPUT DURING OPERATION (POWER OPTIMIZER CONNECTED TO OPERATING SOLAREEDGE INVERTER)							
Maximum Output Current						15	Adc
Maximum Output Voltage	60				80	Vdc	
OUTPUT DURING STANDBY (POWER OPTIMIZER DISCONNECTED FROM SOLAREEDGE INVERTER OR SOLAREEDGE INVERTER OFF)							
Safety Output Voltage per Power Optimizer						1 ± 0.1	Vdc
STANDARD COMPLIANCE							
EMC						FCC Part 15 Class B, IEC61000-6-2, IEC61000-6-3	
Safety						IEC62109-1 (class II safety), UL1741, NEC/PVRSS	
Material						UL94 V-0, UV Resistant	
RoHS						Yes	
INSTALLATION SPECIFICATIONS							
Maximum Allowed System Voltage						1000	Vdc
Compatible inverters						All SolarEdge Single Phase and Three Phase inverters	
Dimensions (W x L x H)	129 x 153 x 27.5 / 5.1 x 6 x 1.1	129 x 153 x 33.5 / 5.1 x 6 x 1.3	129 x 153 x 29.5 / 5.1 x 6 x 1.16	129 x 159 x 49.5 / 5.1 x 6.3 x 1.9	129 x 162 x 59 / 5.1 x 6.4 x 2.3	mm / in	
Weight (including cables)	630 / 1.4	750 / 1.7	655 / 1.5	845 / 1.9	1064 / 2.3	gr / lb	
Input Connector						MC4 ⁽³⁾	
Input Wire Length ⁽⁴⁾						0.16 / 0.5	m / ft
Output Wire Type / Connector						Double Insulated / MC4	
Output Wire Length						1.2 / 3.9	m / ft
Operating Temperature Range ⁽⁵⁾						-40 to +85 / -40 to +185	°C / °F
Protection Rating						IP68 / NEMA6P	
Relative Humidity						0 - 100	%

(1) Rated power of the module at STC will not exceed the optimizer "Rated Input DC Power". Modules with up to +5% power tolerance are allowed.
 (2) NEC 2017 requires max input voltage be not more than 80V.
 (3) For other connector types please contact SolarEdge.
 (4) Longer inputs wire lengths are available for use. For 0.9m input wire length order P401-xx04.xxx.
 (5) For ambient temperature above +85°C / +185°F power de-rating is applied. Refer to Power Optimizers Temperature De-Rating Technical Note for more details: <https://www.solaredge.com/sites/default/files/se-temperature-de-rating-note-na.pdf>

PV System Design Using a SolarEdge Inverter ⁽⁶⁾⁽⁷⁾	Single Phase HD-Wave	Single phase	Three Phase for 208V grid	Three Phase for 277/480V grid	
Minimum String Length (Power Optimizers)	P370, P400, P401 P485, P505	8 6	10 8	18 14	
Maximum String Length (Power Optimizers)		25	25	50	
Maximum Power per String	5700 ⁽⁸⁾ (6000 with SE7600-US - SE11400-US)	5250 ⁽⁸⁾	6000 ⁽⁹⁾	12750 ⁽¹⁰⁾	W
Parallel Strings of Different Lengths or Orientations					Yes

(6) For detailed string sizing information, refer to http://www.solaredge.com/sites/default/files/string_sizing_na.pdf
 (7) It is not allowed to mix P485/P505 with P370/P400/P401 in one string.
 (8) A string with more than 30 optimizers does not meet NEC rapid shutdown requirements, safety voltage will be above the 30V requirement.
 (9) For the 208V grid, it is allowed to install up to 6,500W per string when the maximum power difference between each string is 1,000W.
 (10) For 277/480V grid: it is allowed to install up to 15,000W per string when the maximum power difference between each string is 2,000W.

© SolarEdge Technologies, Ltd. All rights reserved. SOLAREEDGE, the SolarEdge logo, OPTIMIZED BY SOLAREEDGE are trademarks or registered trademarks of SolarEdge Technologies, Inc. All other trademarks mentioned herein are trademarks of their respective owners. Date: July 12, 2022 DS-000044-NAM. Subject to change without notice.



RoHS

ENGINEER:

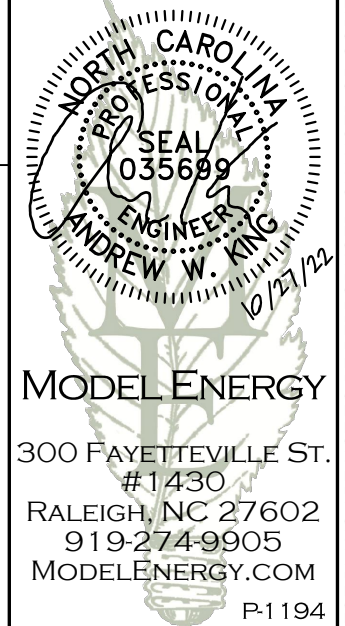

MODEL ENERGY

300 FAYETTEVILLE ST.
#1430
RALEIGH, NC 27602
919-274-9905
MODELENERGY.COM
P-1194

JOB TITLE:

NEW SOLAR PV SYSTEM
29.20 kW DC INPUT
20.00 kW AC EXPORT

Jennifer Zemo
345 Rawls Club Rd,
Fuquay-Varina, NC 27526

CLIENT:

READY SOLAR

ISSUED FOR:	DATE:
CONSTRUCTION	V1-07/20/22
	V2-10/27/22

EQUIPMENT SPEC SHEETS

PV5.2

© 2022 MODEL ENERGY, PLLC EXPRESSLY RESERVES ITS COMMON LAW COPYRIGHT AND OTHER PROPERTY RIGHTS IN THESE PLANS. THESE PLANS ARE NOT TO BE REPRODUCED, CHANGED OR COPIED IN ANY FORM OR MANNER WHATSOEVER, NOR ARE THEY TO BE ASSIGNED TO ANY THIRD PARTY WITHOUT FIRST OBTAINING THE EXPRESSED WRITTEN PERMISSION AND CONSENT OF MODEL ENERGY, PLLC.

Single Phase Inverter with HD-Wave Technology for North America

SE3000H-US / SE3800H-US / SE5000H-US / SE6000H-US / SE7600H-US / SE10000H-US / SE11400H-US

12-25
YEAR
WARRANTY



INVERTERS

Optimized installation with HD-Wave technology

- Specifically designed to work with power optimizers
- Record-breaking 99% weighted efficiency
- Quick and easy inverter commissioning directly from a smartphone using the SolarEdge SetApp
- Fixed voltage inverter for longer strings
- Integrated arc fault protection and rapid shutdown for NEC 2014, NEC 2017 and NEC 2020 per article 690.11 and 690.12
- UL1741 SA certified, for CPUC Rule 21 grid compliance
- Small, lightweight, and easy to install both outdoors or indoors
- Built-in module-level monitoring
- Optional: Faster installations with built-in consumption metering (1% accuracy) and production revenue grade metering (0.5% accuracy, ANSI C12.20)

solaredge.com



Single Phase Inverter with HD-Wave Technology for North America

SE3000H-US / SE3800H-US / SE5000H-US / SE6000H-US / SE7600H-US / SE10000H-US / SE11400H-US

MODEL NUMBER	SE3000H-US	SE3800H-US	SE5000H-US	SE6000H-US	SE7600H-US	SE10000H-US	SE11400H-US	
APPLICABLE TO INVERTERS WITH PART NUMBER	SEXXXXH-XXXXXBXX4							
OUTPUT								
Rated AC Power Output	3000	3800 @ 240V 3300 @ 208V	5000	6000 @ 240V 5000 @ 208V	7600	10000	11400 @ 240V 10000 @ 208V	VA
Maximum AC Power Output	3000	3800 @ 240V 3300 @ 208V	5000	6000 @ 240V 5000 @ 208V	7600	10000	11400 @ 240V 10000 @ 208V	VA
AC Output Voltage Min.-Nom.-Max. (211 - 240 - 264)	✓	✓	✓	✓	✓	✓	✓	Vac
AC Output Voltage Min.-Nom.-Max. (183 - 208 - 229)	-	✓	-	✓	-	-	✓	Vac
AC Frequency (Nominal)	59.3 - 60 - 60.5 ⁽¹⁾							Hz
Maximum Continuous Output Current @240V	12.5	16	21	25	32	42	47.5	A
Maximum Continuous Output Current @208V	-	16	-	24	-	-	48.5	A
Power Factor	1, Adjustable - 0.85 to 0.85							
GFDI Threshold	1							A
Utility Monitoring, Islanding Protection, Country Configurable Thresholds	Yes							
INPUT								
Maximum DC Power @240V	4650	5900	7750	9300	11800	15500	17650	W
Maximum DC Power @208V	-	5100	-	7750	-	-	15500	W
Transformer-less, Ungrounded	Yes							
Maximum Input Voltage				480				Vdc
Nominal DC Input Voltage	380			400				Vdc
Maximum Input Current @240V ⁽²⁾	8.5	10.5	13.5	16.5	20	27	30.5	Adc
Maximum Input Current @208V ⁽²⁾	-	9	-	13.5	-	-	27	Adc
Max. Input Short Circuit Current	45							Adc
Reverse-Polarity Protection	Yes							
Ground-Fault Isolation Detection	600k Ω Sensitivity							
Maximum Inverter Efficiency	99	99.2						%
CEC Weighted Efficiency	99						99 @ 240V 98.5 @ 208V	%
Nighttime Power Consumption	< 2.5							W

(1) For other regional settings please contact SolarEdge support
(2) A higher current source may be used; the inverter will limit its input current to the values stated

ENGINEER:

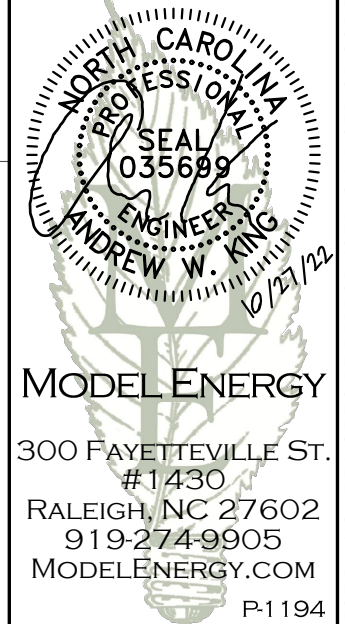

MODEL ENERGY
300 FAYETTEVILLE ST.
#1430
RALEIGH, NC 27602
919-274-9905
MODELENERGY.COM
P-1194

JOB TITLE:

NEW SOLAR PV SYSTEM
29.20 kW DC INPUT
20.00 kW AC EXPORT

Jennifer Zemo
345 Rawls Club Rd,
Fuquay-Varina, NC 27526

CLIENT:

READY SOLAR

ISSUED FOR:	DATE:
CONSTRUCTION	V1-07/20/22
	V2-10/27/22

EQUIPMENT
SPEC SHEETS

PV5.3

© 2022 MODEL ENERGY, PLLC EXPRESSLY RESERVES ITS COMMON LAW COPYRIGHT AND OTHER PROPERTY RIGHTS IN THESE PLANS. THESE PLANS ARE NOT TO BE REPRODUCED, CHANGED OR COPIED IN ANY FORM OR MANNER WHATSOEVER, NOR ARE THEY TO BE ASSIGNED TO ANY THIRD PARTY WITHOUT FIRST OBTAINING THE EXPRESSED WRITTEN PERMISSION AND CONSENT OF MODEL ENERGY, PLLC.