

SILFAB PRIME

SIL-380 HC

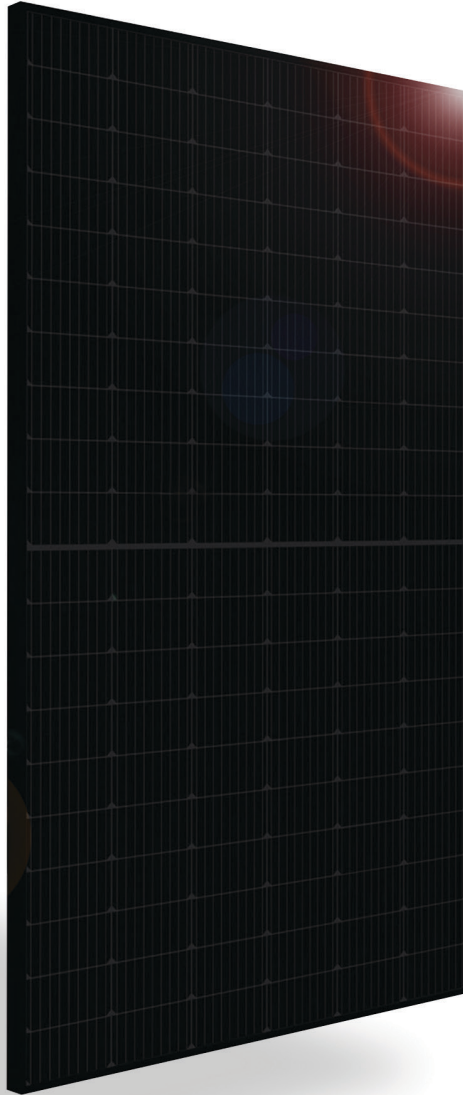

❖ RELIABLE ENERGY.
DIRECT FROM THE SOURCE.

Introducing Silfab Prime.

Designed to outperform.

Dependable, durable, high-performance solar panels
engineered for North American homeowners.

SILFABSOLAR.COM

PROUD
PARTNER OF

The logo for ION, consisting of the letters "ION" in a white, bold, sans-serif font centered within a solid black square.



CHUBB®

* Chubb provides error and omission insurance to Silfab Solar Inc.

ELECTRICAL SPECIFICATIONS		380	
Test Conditions		STC	NOCT
Module Power (Pmax)	Wp	380	284
Maximum power voltage (Vpmax)	V	35.32	32.83
Maximum power current (Ipmax)	A	10.77	8.64
Open circuit voltage (Voc)	V	42.17	39.55
Short circuit current (Isc)	A	11.36	9.16
Module efficiency	%	20.8%	19.4%
Maximum system voltage (VDC)	V		1000
Series fuse rating	A		20
Power Tolerance	Wp		±3%

Measurement conditions: STC 1000 W/m² • AM 1.5 • Temperature 25 °C • NOCT 800 W/m² • AM 1.5 • Measurement uncertainty ≤ 3%
Sun simulator calibration reference modules from Fraunhofer Institute. Electrical characteristics may vary by ±5% and power by ±3%.

MECHANICAL PROPERTIES / COMPONENTS	METRIC	IMPERIAL
Module weight	19.5kg ±0.2kg	43lbs ±0.4lbs
Dimensions (H x L x D)	1762 mm x 1037 mm x 35 mm	69.4 in x 40.8 in x 1.37 in
Maximum surface load (wind/snow)*	5400 Pa rear load / 5400 Pa front load	112.8 lb/ft ² rear load / 112.8 lb/ft ² front load
Hail impact resistance	ø 25 mm at 83 km/h	ø 1 in at 51.6 mph
Cells	120 Half cells - Si mono PERC 9 busbar - 83 x 166 mm	120 Half cells- Si mono PERC 9 busbar - 3.26 x 6.53 in
Glass	3.2 mm high transmittance, tempered, DSM antireflective coating	0.126 in high transmittance, tempered, DSM antireflective coating
Cables and connectors (refer to installation manual)	1350 mm, ø 5.7 mm, MC4 from Staubli	53.15 in, ø 0.22 in (12AWG), MC4 from Staubli
Backsheet	High durability, superior hydrolysis and UV resistance, multi-layer dielectric film, fluorine-free PV backsheet	
Frame	Anodized Aluminum (Black)	
Bypass diodes	3 diodes-30SQ045T (45V max DC blocking voltage, 30A max forward rectified current)	
Junction Box	UL 3730 Certified, IEC 62790 Certified, IP68 rated	

TEMPERATURE RATINGS		WARRANTIES	
Temperature Coefficient Isc	+0.064 %/°C	Module product workmanship warranty	25 years**
Temperature Coefficient Voc	-0.28 %/°C	Linear power performance guarantee	30 years
Temperature Coefficient Pmax	-0.36 %/°C		≥ 97.1% end 1st yr ≥ 91.6% end 12th yr ≥ 85.1% end 25th yr ≥ 82.6% end 30th yr
NOCT (± 2°C)	45 °C		
Operating temperature	-40/+85 °C		

CERTIFICATIONS		SHIPPING SPECS	
Product	ULC ORD C1703, UL1703, CEC listed, UL 61215-1/-1-1/-2, UL 61730-1/-2, IEC 61215-1/-1-1/-2***, IEC 61730-1/-2***, CSA C22.2#61730-1/-2, IEC 62716 Ammonia Corrosion; IEC61701:2011 Salt Mist Corrosion Certified, UL Fire Rating: Type 2	Modules Per Pallet:	26 or 26 (California)
Factory	ISO9001:2015	Pallets Per Truck	34 or 32 (California)
		Modules Per Truck	884 or 832 (California)

* ⚠ Warning. Read the Safety and Installation Manual for mounting specifications and before handling, installing and operating modules.

** 12 year extendable to 25 years subject to registration and conditions outlined under "Warranty" at silfabsolar.com

*** Certification in progress.

PAN files generated from 3rd party performance data are available for download at: silfabsolar.com/downloads

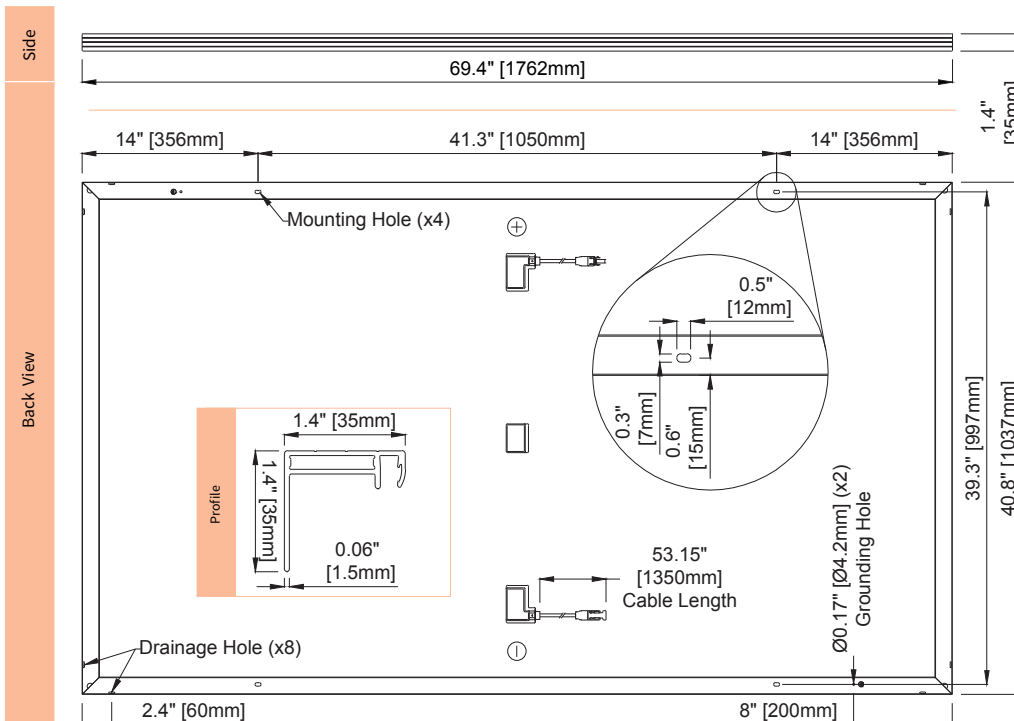

T +1 888.781.7074
IONSOLAR.COM

SILFAB SOLAR INC.

800 Cornwall Ave
Bellingham WA 98225 USA
T +1 360.569.4733
info@silfabsolar.com
SILFABSOLAR.COM

1770 Port Drive
Burlington WA 98233 USA
T +1 360.569.4733

240 Courtneypark Drive East
Mississauga ON L5T 2Y3 Canada
T +1 905.255.2501
F +1 905.696.0267

Silfab - SIL-380-HC-20211101

No reproduction of any kind is allowed without permission. Data and information is subject to modifications without notice. © Silfab Solar Inc., 2021. Silfab Solar™ is a trademark of Silfab Solar Inc.



**RAPID
INSTALLATION,
HIGH-QUALITY SOLAR
MOUNTING SYSTEM
FOR SHINGLE AND
TILE ROOFS**

CLICKFIT



www.ecofastensolar.com

Fire Rating**	Class A System Fire Rating
Max System Voltage	1500 VDC
Max Fuse Rating	30A
Certification	Conforms to UL STD 2703
Warranty	20 Year Material and Workmanship
UL 2703 Markings	Product listing label is located on the rail end-caps
Roof Pitch	2:12 – 12:12
UL 2703 Allowable Design Load Rating	10 psf downward, 5 psf upward, and 5 psf lateral
Max Module Size	24 sqft
Module Orientation:	Portrait or Landscape

**Class A System fire rating with Type 1 & 2 PV modules. Any module-to-roof gap is permitted, with no skirt required. This rating is applicable with any roof attachment.

NOTE: Mid Clamp, MLPE Clip, and MLPE Bracket have been evaluated for multiple use, position independent.

UL 2703 Marking Example:

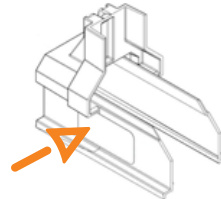

Torque Specifications

Component	Torque (in-lb)	Notes
Lag Screw	N/A	Fully Seat. Use visual indicator of the black EPDM ring around the bonded washer for torquing.
Mid-Clamp	144	
End-Clamp	96	
Rail Clicker Leveling Bolt	142	Pre-torqued upon delivery. Applies to Tile Hook and L-Footer/Clicker
Hook Height Bolt	N/A	Lightly clamp hook to flush with top of next tile row
Ground Lug	N/A	Refer to specific ground lug manufacturer's installation manual
MLPE Clip	144	
MLPE Mount	144	

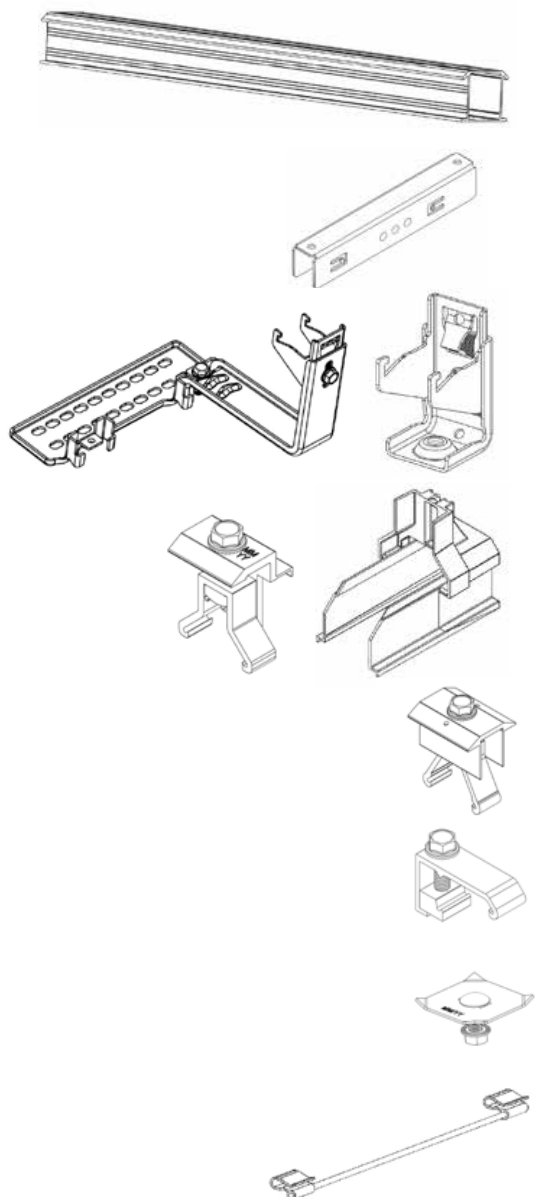
- 
- 1) ClickFit Rail
1500033 (2130mm)
1500034 (3166mm)
1500035 (4202mm)
 - 2) Rail Splice
1008061
 - 3) CF Tile Hook and L foot
1500005 - Tile Hook
1500004 - L foot
 - 4) CF End Clamp
See Section 10
 - 5) CF End Cap
1510041 (Black)
1510042 (Grey)
 - 6) CF Mid Clamp
See Section 10
 - 7) MLPE Mount
1510057
 - 8) MLPE Clip (RockIt Clip 2.0)
 - 9) Module Jumper
1500028

Checklist of tools and accessories

Note: *Proper PPE shall be worn at all times*

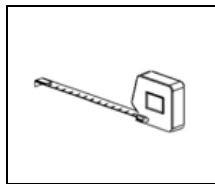

Tape measure

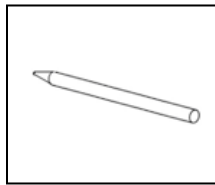

Roof crayon or chalk (a chalk line can be helpful as well)

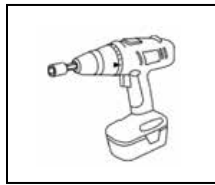

Cordless drill with torque adjustment and the following bits:

- 1/2" Hex socket
- 1/4" diameter drill bit. (Drilling length no less than lag bolt depth)

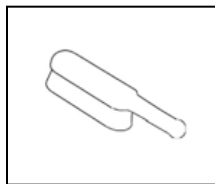

Brush for clearing debris from roof surface. Hint: Leaf blowers work well to remove any leftover moisture prior to installation.



Torque wrench capable of 0-150 in-lbs

- Refer to span tables, local jurisdiction, or engineer of record specifications when determining setbacks from roof edges, attachment spans, etc.
- Mark the perimeter and corners of the array on the roof surface.
 - *Add 3/4" to account for the gap between modules in each direction***
- Draw or snap chalk lines where the rails will be installed,(refer to module manufacturer specs to determine allowable mounting locations).
- Locate rafters within the area of the array. It may be necessary to shift the array East or West on the roof in order to fall within the rail cantilever specs (1/3) of span).
- Stagger rafters every row if required by the local jurisdiction, engineer of record, or company policy.

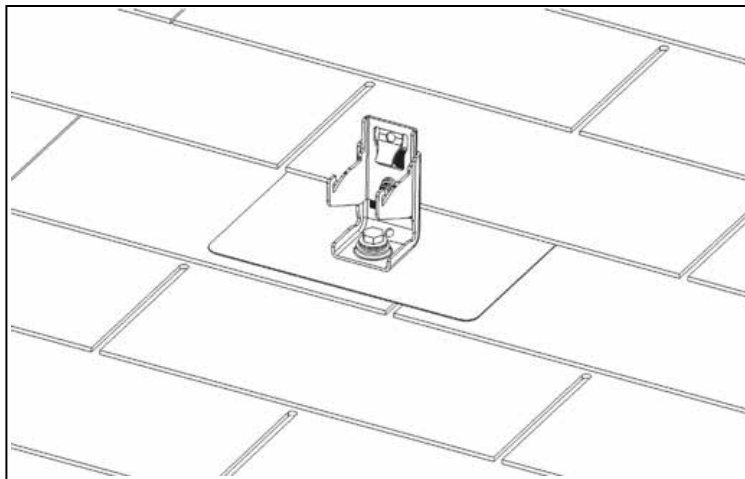

Pre-installing rail splices

1. Determine the number of rails required per row of modules.
2. Insert a rail splice into one rail. *Do not push it past the center bump.*
3. Slide the next rail onto the rail splice until the two rail ends meet.
4. Repeat steps 2 and 3 until the desired length is achieved. *This is usually easiest to do from the ground.*

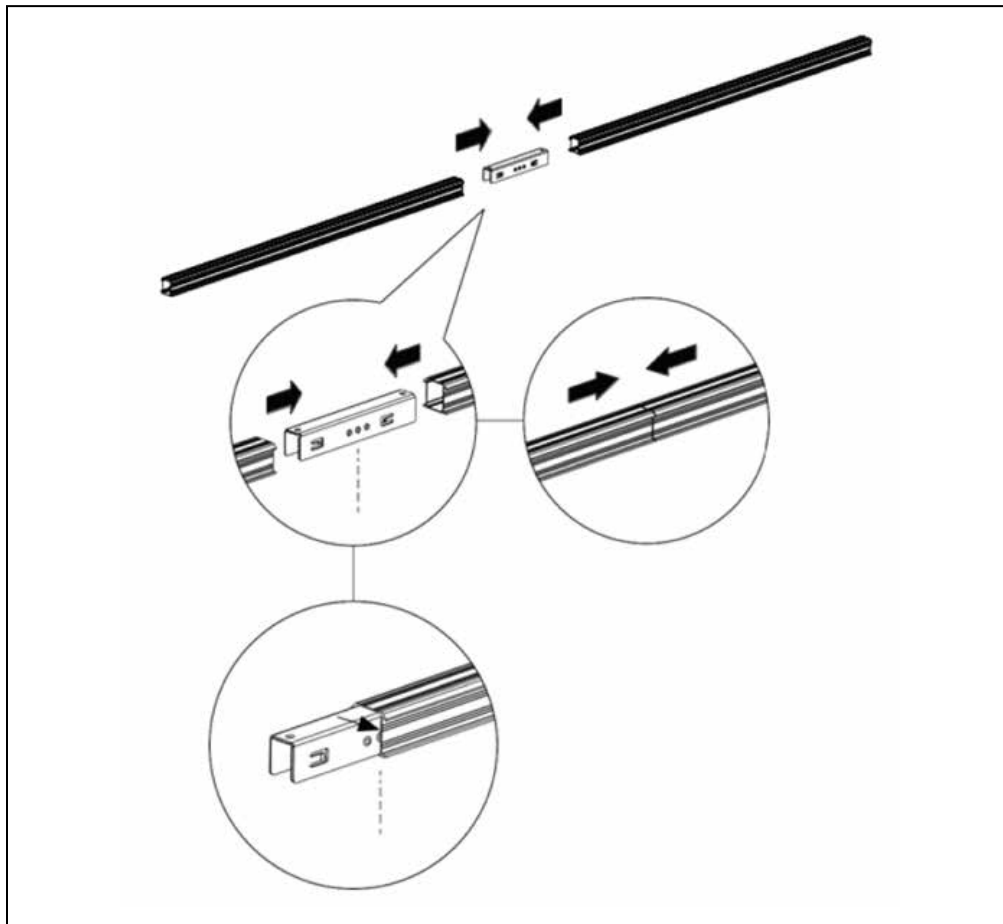

Installation of flashing and L feet

- ClickFit for comp shingle roofs uses EcoFasten Solar's GFI watertight flashing system
- Other roof types may use different EcoFasten Solar attachments, see www.EcoFastenSolar.com for more information.

Installation Steps:

1. Locate rafter lines from section 5.2.
2. Drill 1/4" pilot holes at all attachment points and back fill using roof-compatible sealant.
3. Separate shingles where flashing is to be installed. Insert the flashing so the top portion is under the next row of shingles North. Ensure the flashing is pushed to the third-course of shingle to prevent water infiltration through the vertical joints between shingles.
4. Align GFI flashing hole with pilot hole. Insert the lag bolt with pre-installed bonded washer through the L foot and EPDM grommet. Tighten the lag bolt until a ring of EPDM is visible around the circumference of the bonded washer.

Tighten the lag until fully seated. The EPDM Ring visual indicator is the most effective way to ensure a watertight seal.

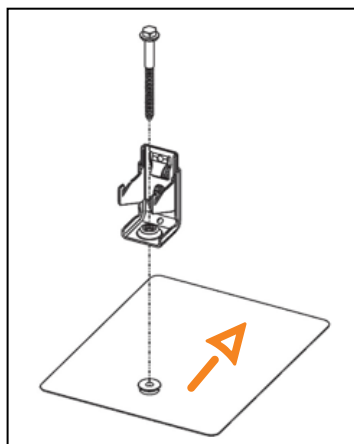
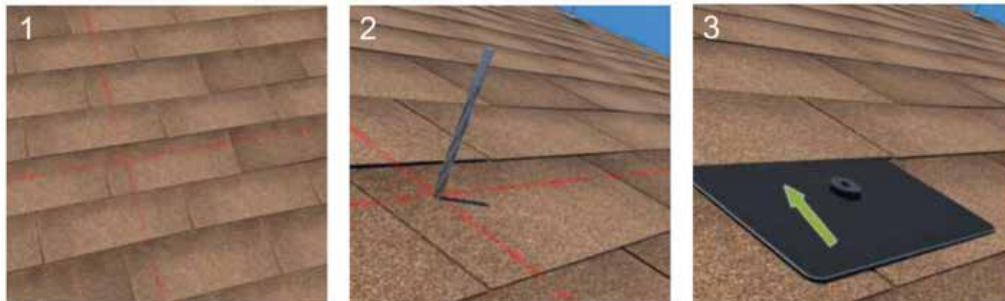

Note the orientation of the L foot and Clicker. The two Clicker "arms" should be facing downslope

1. Locate rafters on the roof, mark the tiles to be removed. Hint: In some cases rafter tails are visible at the eaves of the roof, making it easy to find the rough location of the rafters. In other cases, the fascia board may have nail heads visible where it was attached to the rafters. In the worst-case a row of tiles may need to be moved to determine the rafter locations.
2. Slide the tile at the desired location upward to expose the roof sub surface. If the tile is to be notched, or if using a replacement flashing, remove it entirely. Clean the sub surface with a brush to remove any debris that could affect the sealing.
3. Locate the rafter center and mark it.
4. Place the tile hook with the hook itself in the valley of the next tile below. Drill one 1/4" pilot hole in the rafter center, taking care to keep the hook in the valley of the tile below. Backfill this hole with a roof-compatible sealant. For flat tiles, try to avoid having the hook land directly under a joint between tiles, this will create a larger gap or more notching than necessary.
5. Install one 5/16" x 4" lag screw on the row of holes closest to the tile hook arm. If possible, install the screw in one of the three holes directly next to the arm. If the lag screw must be installed in one of the seven holes furthest from the arm (denoted by the red rectangle below), install three deck screws in the pattern shown by the green circles below.
6. Adjust the height of the tile hook as necessary using the bolt shown in the fourth image.
7. Flash the surrounding area and lag screw head with roof-compatible sealant as necessary. Refer to Tile Hook Subflashing Installation guide on the next page.
8. Replace the tile that was moved and/or removed, or install the tile replacement flashing. If it is to be notched, mark the tile for notching. Notching can be done with a grinding wheel or by using a chisel.

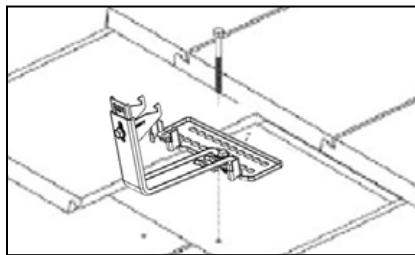

5.

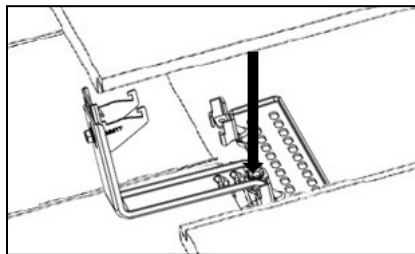
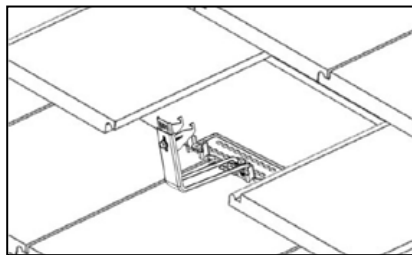

6.

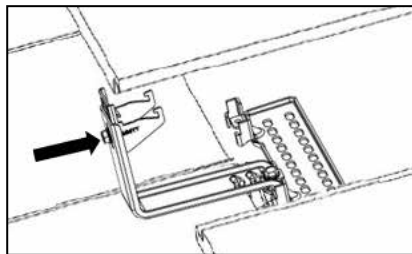

CLICKFIT TILE HOOK SUB-FLASHING INSTALLATION STEPS:

Tools Required: Caulking gun, roofing mastic applicator

Materials Required: Roofing mastic, reinforcing fabric, roof sealant

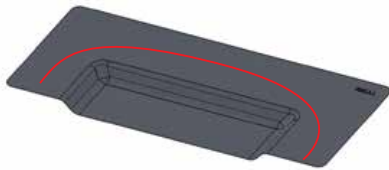

Apply a continuous line of the roofing manufacturer's approved sealant on the underside of the ClickFit tile hook sub-flashing to form a U-shape around the raised edges.

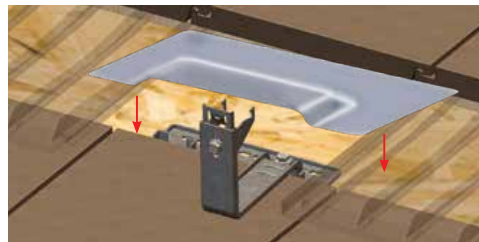

Lower the sub-flashing over the tile hook base. It may be necessary to move adjacent tiles to easily lower the sub-flashing onto the roof deck.

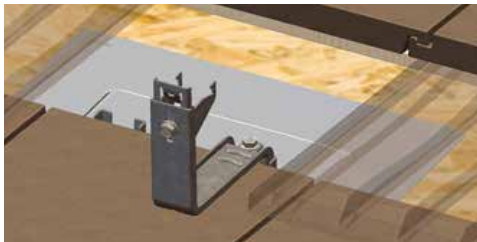

Place the sub-flashing over the base of the tile hook so the flashing covers the entire base.

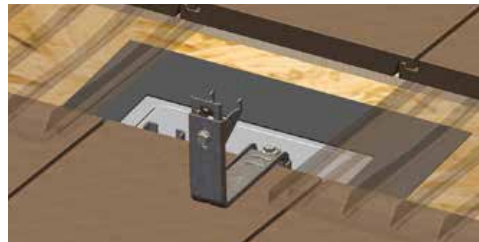

EcoFasten recommends following the TRI guidelines three-course sealing method. Start the three-course sealing method by applying a layer of roofing mastic over the edges of the tile hook sub-flashing.

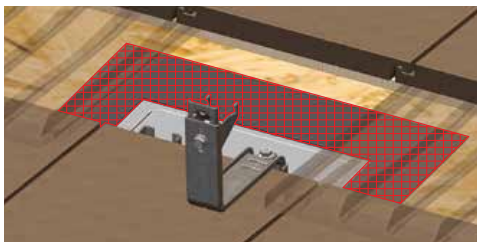

Place strips of reinforcing fabric over mastic to cover approximately 2" from the edge of the sub-flashing in both directions. Place strips on the side first, then the top edge.



Apply a final layer of mastic to completely cover the reinforcing fabric. The flashing is now installed and sealed.

1. Place the rail in the Clickers.
2. Ensure the rails extend a minimum of 2" past the last attachments in each row and that each rail is aligned with the next row North and/or South.
3. Roll the rail into each Clicker, an audible "click" should be heard. If attachments are extremely misaligned it may be necessary to loosen the leveling bolt, snap the Clicker onto the rail, then re-tighten the leveling bolt to 142 in-lbs.
4. Level the rail if necessary by loosening the bolt attaching the Clicker to the L foot or tile hook.

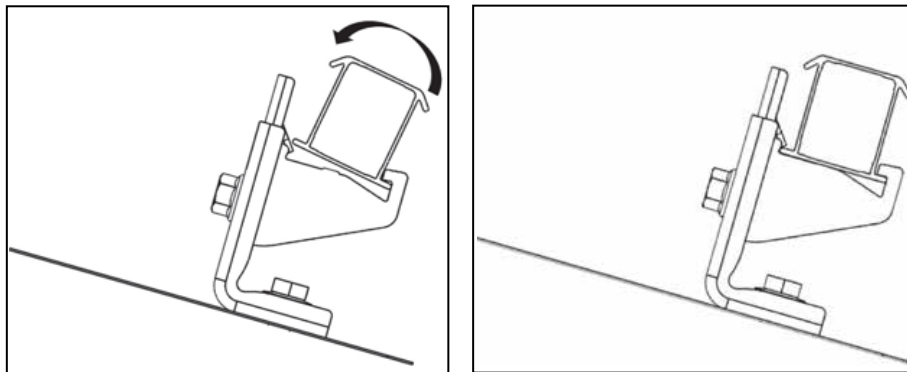

Ensure the tab on the Clicker is aligned with the rail edge as shown below

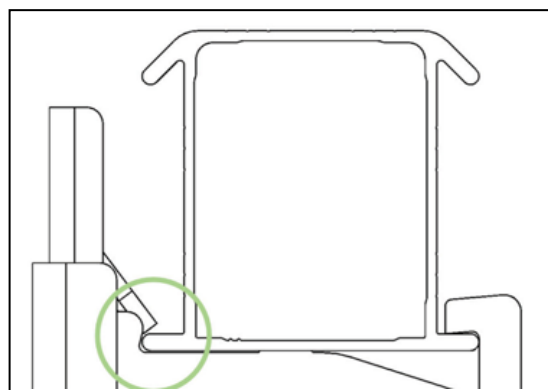

1. Install the end clamps on each rail on whatever end you are starting with.
 - Snap the end clamp onto the rail.
 - Slide the end cap onto the rail.
 - Turn the leg of the end clamp around the cap.

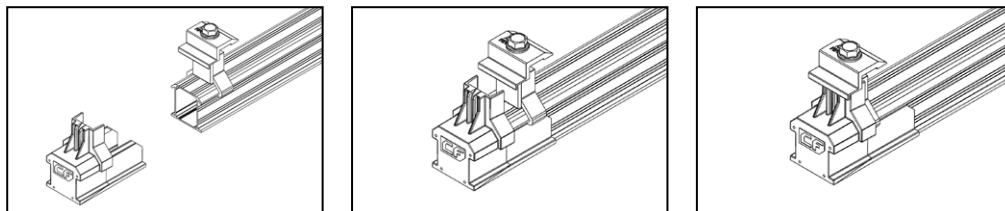

2. Place the module on the rail.
 - *Ensure module junction box is up-slope.***

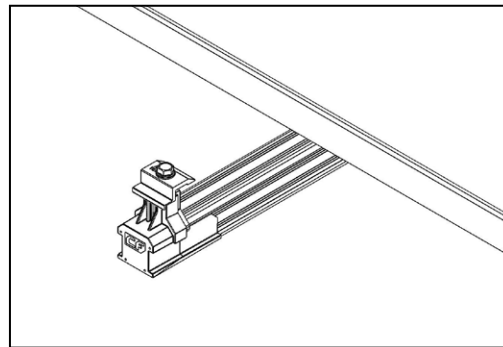

3. Slide the module to the end clamp and align it with the array corners. Tighten the end clamp to 96 in-lb.

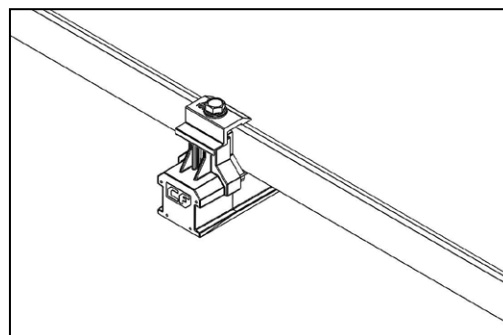

6.6 Installing additional modules on the rail

1. Click a mid clamp onto each rail.

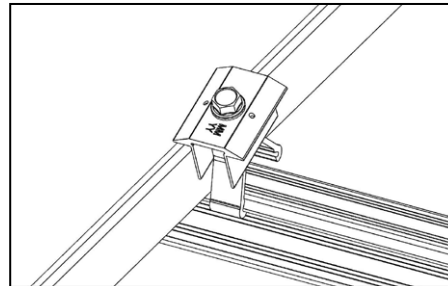

2. Slide the mid clamps until they are flush with the side of the existing module.

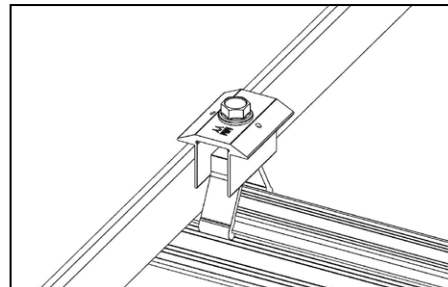

3. Place and slide the next module firmly against the mid clamps. Align the bottom edges of the modules. Tighten mid clamps to 144 in-lb.

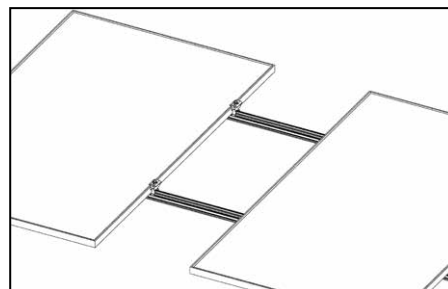

6.7 INSTALLING END CLAMPS AT THE END OF A ROW

1. Install the last mid clamps in the row.
2. Measure the rails from the last mid clamp to the module width plus 1".
3. Cut the rails at this mark. There is some adjustment in the end cap/clamp so it does not need to be a perfect cut.
4. Install end clamps and end caps, tighten to 96 in-lb

Alternative method:

1. Install the last module in the row, tighten the mid clamps.
2. Using a circular saw with a metal blade, or carefully with a reciprocating saw, cut the rail approximately 1" past the edge of the last module.
3. Install end clamps and end caps, tighten to 96 in-lb

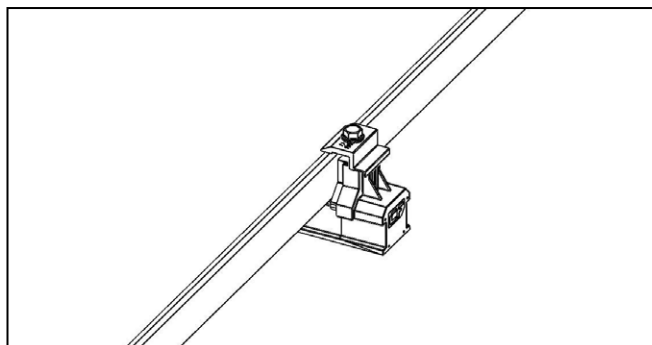
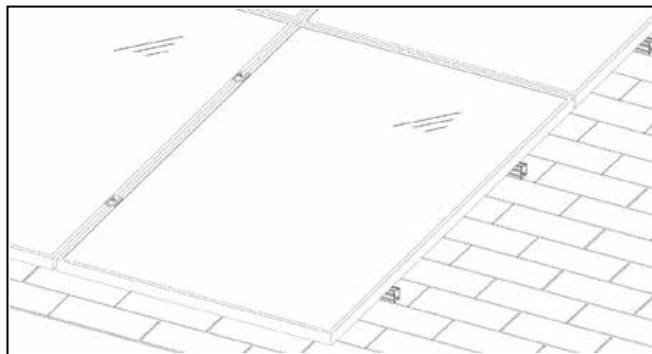

6.8 Installing additional rows of modules

1. Place the first module of the next row against the end clamps.
2. Temporarily place a mid clamp in the N-S gap between rows of modules, slide the modules up to the mid clamp as shown below.
3. Once the modules are aligned tighten the end clamps.
4. Install Dynobond clip on the bottom lip of the module frames to bond rows together.
5. Repeat steps 6.5-6.7 until the array is complete.

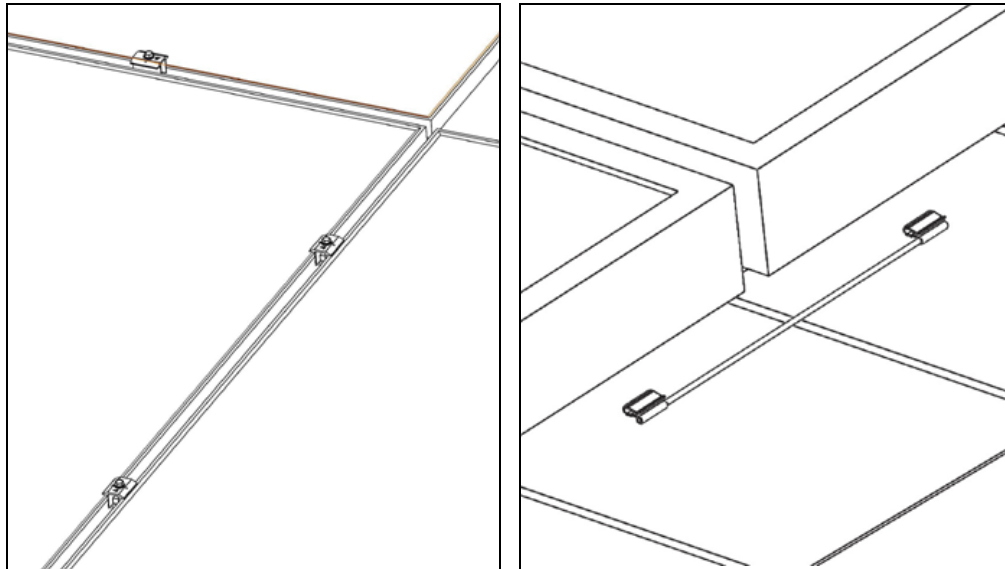

Bonding Paths

All bond paths are carried either module-to-module through the mid clamp, or module-to-module through the module jumper shown below (bond paths shown in green):

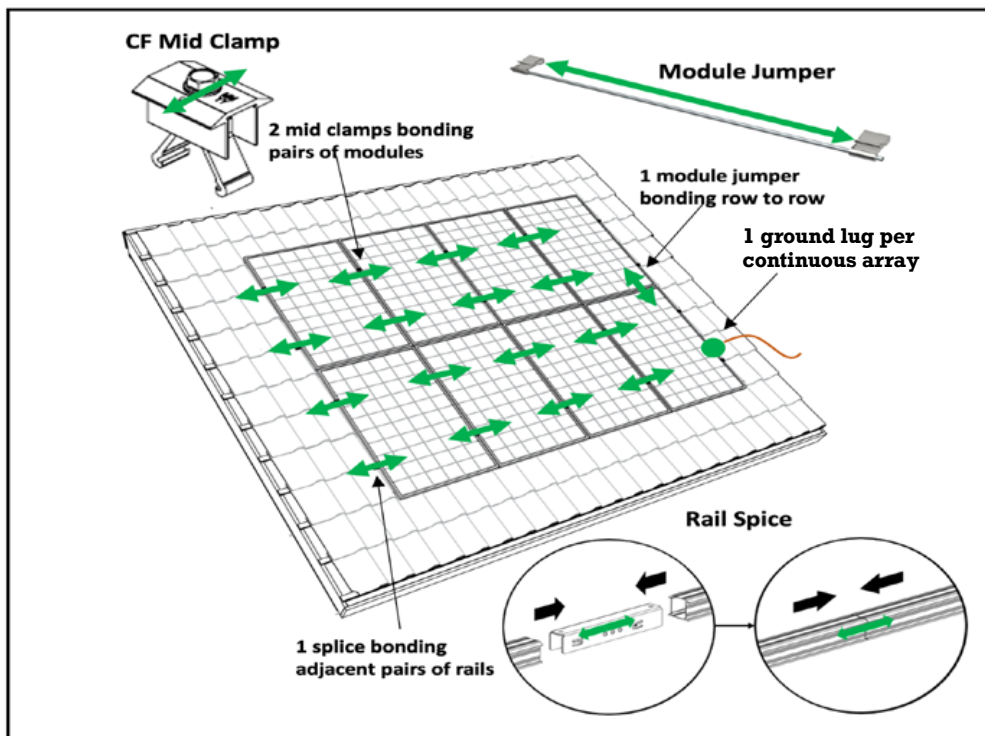

7.2 Grounding

GROUNDING LUG INSTALL

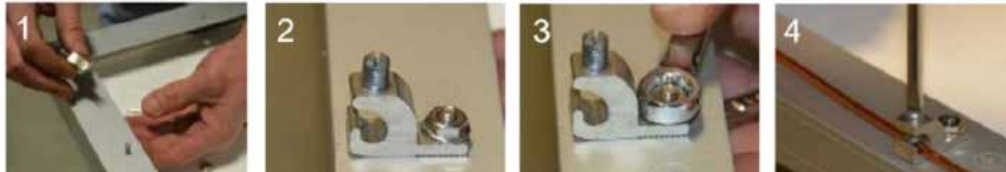

Install ground lug on the module per ground lug and module manufacturer's instructions

NECESSARY COMPONENTS:

On of the following ground lugs (or any UL 2703 compliant ground lug):

- BurndyCL50-1TN Ground Lug (UL 2703 - E3514343 / UL 467-E9999)
- ILSCO SGB-4 Ground Lug (UL 2703 - E354420 | UL 467 - E34440)
- ILSCOGBL-40BT(UL2703 - E354420 | UL467 - E34440)
- ILSCO GBL-4DBTH (UL 2703 - E354420 / UL 467 - E34440)
- ILSCO GBL-455 (UL 2703 - E354420 | UL 467 - E34440)

This system needs to be grounded in accordance with the National Electrical Code, ANSI/NFPA 70.

Copper wire should not come in direct contact with aluminum at any point on the array

7.3 MLPE Clip Installation (Optional)



INSTALL MLPE CLIP ACCESSORY

- Determine mounting location of the MLPE and MLPE Clip on the module frame. Take care not to block drainage holes on the frame.
- Push the nut/bolt of the MLPE Clip so the carriage bolt head is furthest away from the stainless plate.
- Slide the bolt shaft into the slot on the MLPE mounting flange.
- Place the assembly onto the module flange, MLPE mounting flange on the far face (upper side) of the module frame flange, stainless plate on the closer face (bottom side) of the module frame flange.
- Hold the carriage bolt into the MLPE mounting flange slot with your finger, this will keep the carriage bolt from spinning in the slot. Tighten the nut to 144 in-lbs using a 1/2" hex socket.

MLPE CLIP IS COMPATIBLE WITH:

- Enphase Products: M250-72, 250-60, M215-60, C250-72, S230, S280, IQ 6, IQ 6+, IQ, IQ7, IQ 7A, IQ 7+, IQ 7X, Q Aggregator
- SolarEdge Products: P300, P320, P340, P370, P400, P405, P485, P505, P600, P700, P730, P800p, P800s, P850, P860
- See page 21 for compatible module list with MLPE Clip

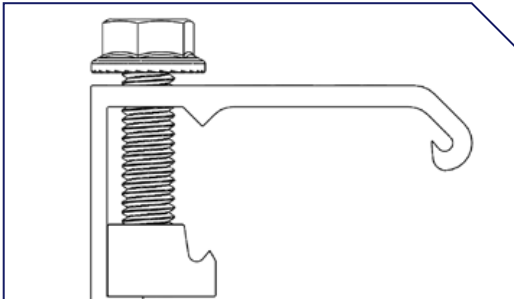

Lower the MLPE Mount to the rail

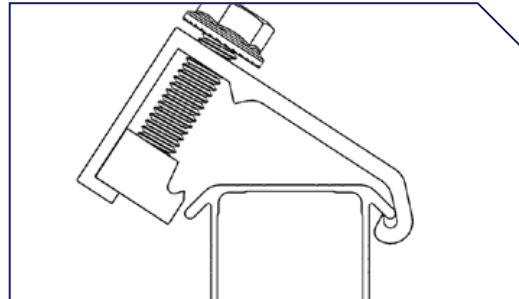

Tilt and hook the mount around the top "dog ear" of the rail

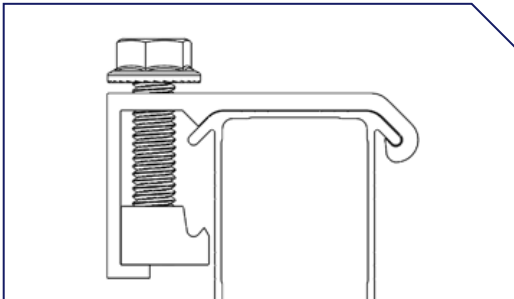

Set the MLPE Mount flush with the top of the rail

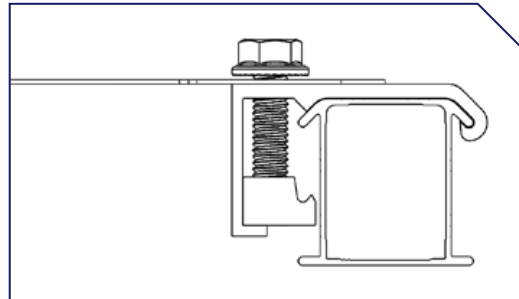

Slide the microinverter flange between the MLPE Mount and the serrated bolt flange

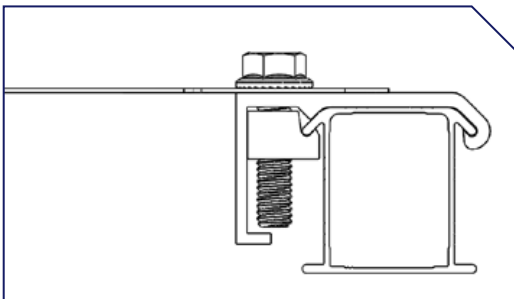

Tighten the bolt to 144 in-lbs

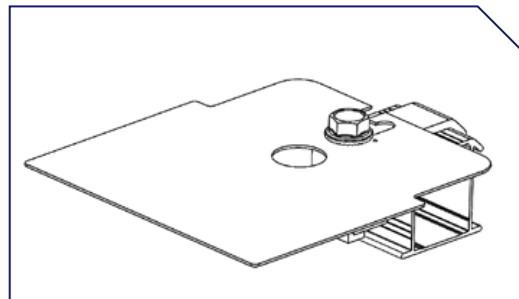

Repeat this process for all other microinverter and/or optimizer installations

MLPE MOUNT IS COMPATIBLE WITH:

Enphase Products: M250-72, 250-60, M215-60, C250-72, S230, S280, IQ 6, IQ 6+, IQ, IQ7, IQ 7A, IQ 7+, IQ 7X, Q Aggregator

SolarEdge Products: P300, P320, P340, P370, P400, P405, P485, P505, P600, P700, P730, P800p, P800s, P850, P860

SILFAB	SILFAB MODULES WITH 38 MM FRAMES SYY-Z-XXXAB WHERE "YY" CAN BE IL, SA, LA, SG OR LG; "Z" CAN BE BLANK, M, P, OR X; "A" CAN BE BLANK, B, H, M, N; AND "B" CAN BE A, L, G, OR T
SOLARIA	SOLARIA MODULES WITH 40 MM FRAMES POWERXT XXXY-ZZ WHERE "Y" CAN BE R OR C; AND "ZZ" CAN BE AC, BD, BX, BY, PD, PM, PM-AC, PX, PZ, WX OR WZ
SOLARCITY (TESLA)	SOLARCITY MODULES WITH 40 MM FRAMES SCXXXXY WHERE "YY" CAN BE BLANK, B1 OR B2
SOLARTECH	SOLARTECH MODULES WITH 42 MM FRAMES STU-XXXXY WHERE "YY" CAN BE PERC OR HJT
SOLARWORLD AG	SOLARWORLD SUNMODULE PLUS, PROTECT, BISUN, XL, BISUN XL, MAY BE FOLLOWED BY MONO, POLY, DUO, BLACK, BK, OR CLEAR; MODULES WITH 31, 33 OR 46 MM FRAMES SW-XXX
SOLARWORLD AMERICAS	SOLARWORLD SUNMODULE PLUS, PROTECT, BISUN, XL, BISUN XL, MAY BE FOLLOWED BY MONO, POLY, DUO, BLACK, BK, OR CLEAR; MODULES WITH 33 MM FRAMES SWA-XXX
SONALI	SONALI MODULES WITH 40 MM FRAMES SSXXX
STION	STION THIN FILM MODULES WITH 35 MM FRAMES STO-XXX OR STO-XXXA
SUNEDISON	SUNEDISON MODULES WITH 35, 40 & 50 MM FRAMES SE-YXXXABCDE WHERE "Y" CAN BE B, F, H, P, R, OR Z; "Z" CAN BE 0 OR 4; "A" CAN BE B,C,D,E,H,I,J,K,L,M, OR N ; "B" CAN BE B OR W; "C" CAN BE A OR C; "D" CAN BE 3, 7, 8, OR 9; AND "E" CAN BE 0, 1 OR 2

End Clamps

Frame Thickness	Article Number
30 mm	1510015
32 mm	1510016
35 mm	1510017
38 mm	1510018
40 mm	1510019
45 mm	1510020
50 mm	1510021

Mid Clamps

Frame Thickness	Article Number
30-40 mm	1510011
40-50 mm	1510012

INSTALLER RESPONSIBILITIES

Periodic reinspection of components shall be performed to verify that there is no corrosion detrimental to system strength and electrical conductivity, no loose bolts, and/or other variables that could compromise array safety. Any corroded or damaged components shall be immediately replaced.

GreenFasten™ GF1 PRODUCT GUIDE

- Exploded Product View/B.O.M. – 1
- Installation Instructions – 2
- Cut Sheets – 3
- Specifications – 4
- Test Data – 5

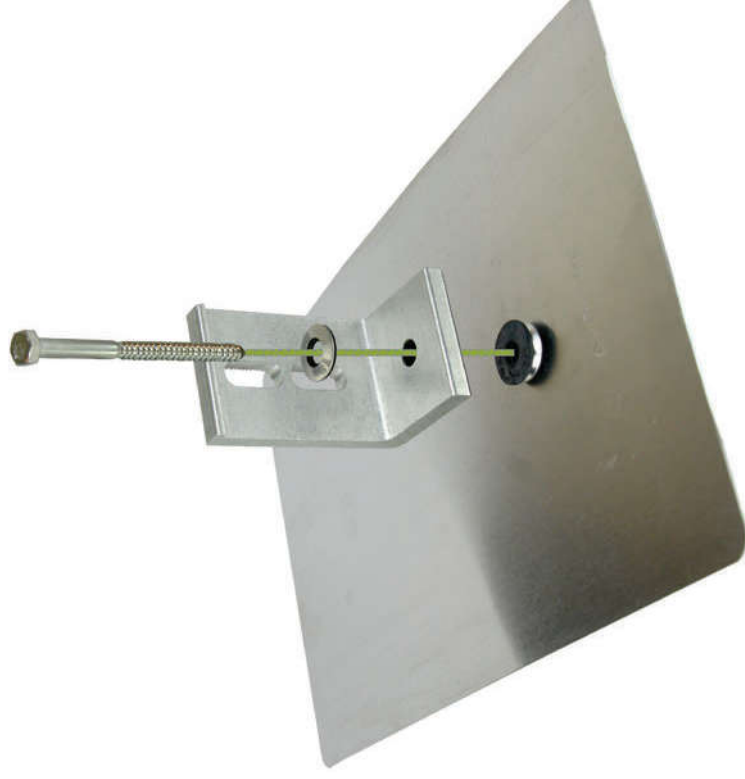

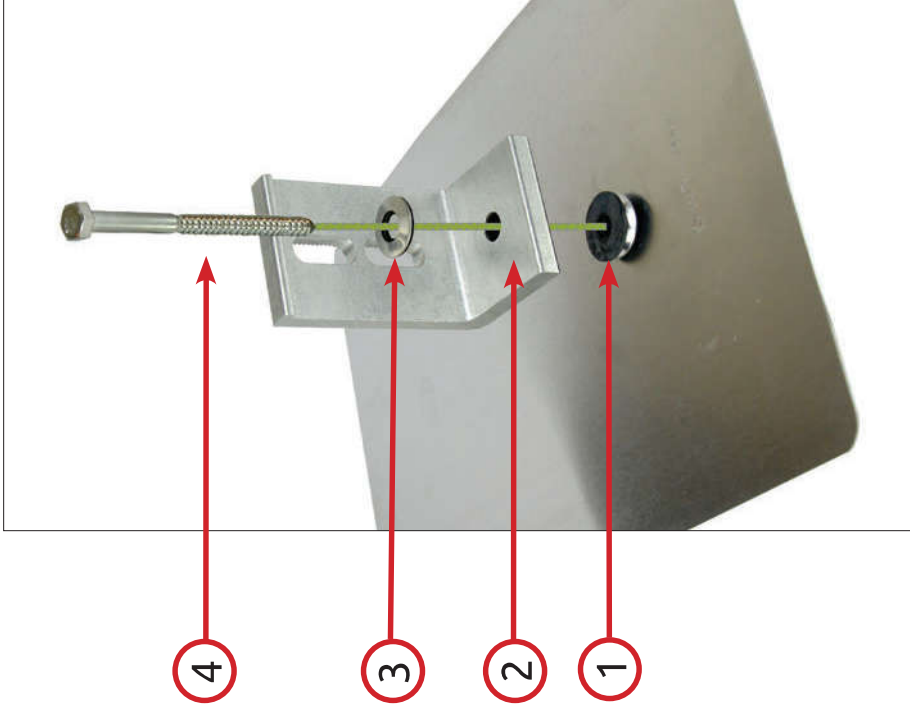

Materials Needed for Assembly

Item No.	Description of Material/Part	Quantity
1	GF-1 Flashing	1
2	L-102-3" Bracket * (other options available)	1
3	5/16" EPDM Bonded 304-18.8 SS Washer	1
4	Lag Bolt 5/16"	1

Required Tools



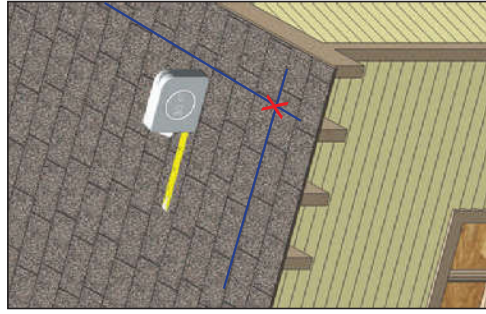

1

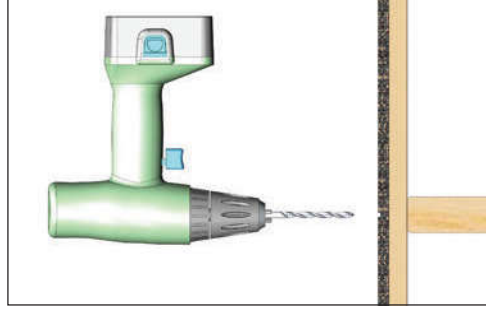

2

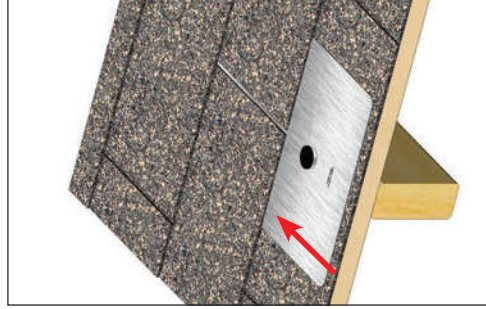

3

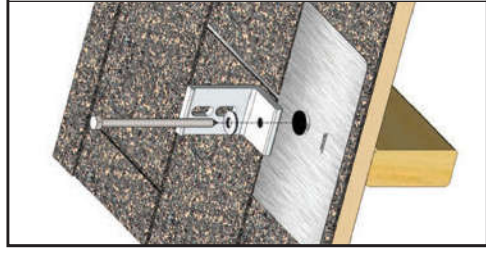

4a

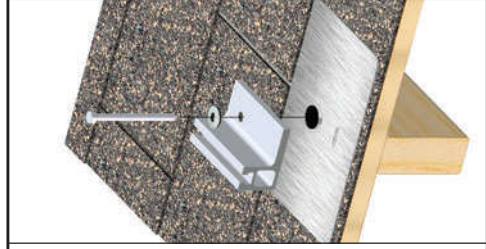

4b

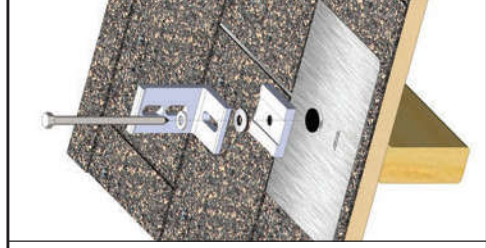

4c

1. Locate the rafters and snap horizontal and vertical lines to mark the installation position for each GreenFasten flashing.
2. Drill a pilot hole (1/4" diameter) for the lag bolt. Backfill with sealant. EcoFasten Solar recommends an EPDM mastic.
3. Insert the flashing so the top part is under the next row of shingles and pushed far enough up slope to prevent water infiltration through vertical joint in shingles. The leading edge of flashing must butt against upper row of nails to prevent turning when torqued. See page 2.2 for vertical adjustment when leading edge of flashing hits nails in upper shingle courses.
4. Line up pilot hole with GreenFasten flashing hole.

4a Insert the lag bolt through the EPDM washer, the top compression component bracket (L-102-3, Rock-It SlideComp*, SCL-101-3*, Z-101*, Conduit Mount Bracket*) and the gasketed hole in the flashing and into the rafter.

4b Insert the lag bolt through the EPDM washer, the Comp Mount Slide compression bracket and the gasketed hole in the flashing and into the rafter.

4c Insert the lag bolt through the SS washer, the third-party bracket, the EPDM bonded washer, the CP-SQ-Slotted compression bracket and the gasketed hole in the flashing and into the rafter.

Consult an engineer or go to www.ecofastensolar.com for engineering data.

5. Torque: The range is between 100-140 torque inch-pounds depending on the type of wood and time of year. The visual indicator for proper torque is when the EPDM on the underside of the bonded washer begins to push out the sides as the washer compresses. If using an impact wrench to install the fasteners be careful not to over torque the fastener. You may need to stop and use a ratchet to finish the install.

*not pictured.

* Use for vertical adjustment when leading edge of flashing hits nails in upper shingle courses

1. Slide flashing up under shingles until leading edge engages nails. Measure remaining distance to adjust upslope.

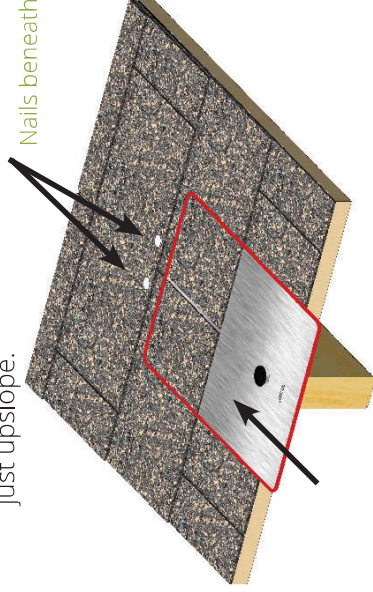

2. Remove flashing and cut "V" notch at marks where nail shafts engaged leading edge of flashing the distance desired in Step 1. Notch depth not to exceed 2" length by 1/2" width.

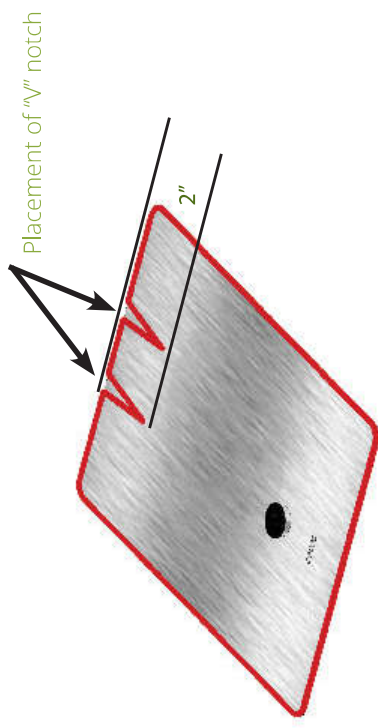

3. Reinstall flashing with notched area upslope.

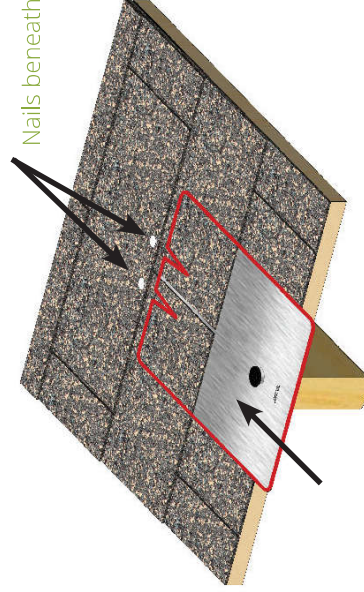

4. Position notched leading edge underneath nail heads as shown.

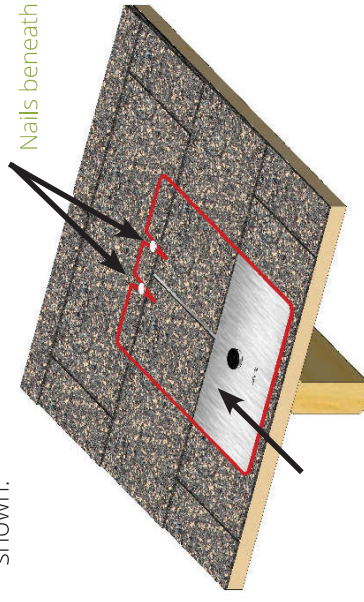

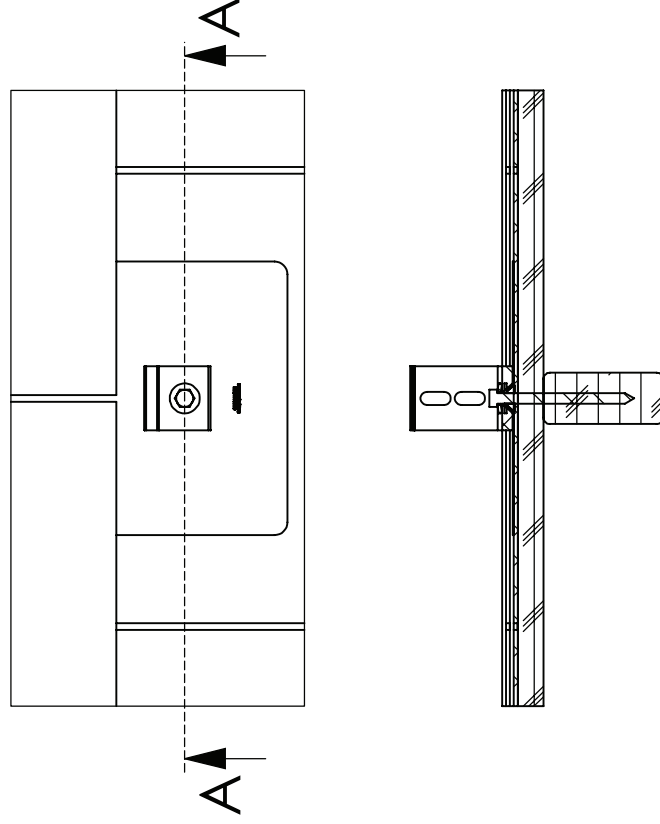

SECTION A-A

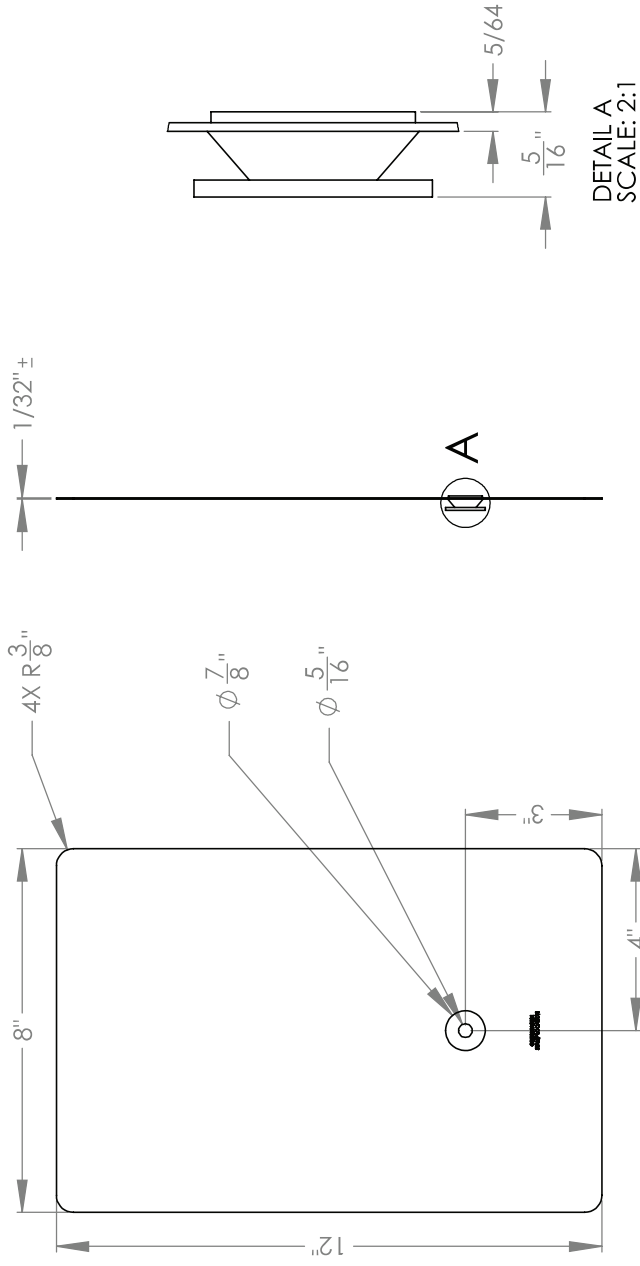

Finish Options
BLK = Matte Black
MLL = Mill Finish

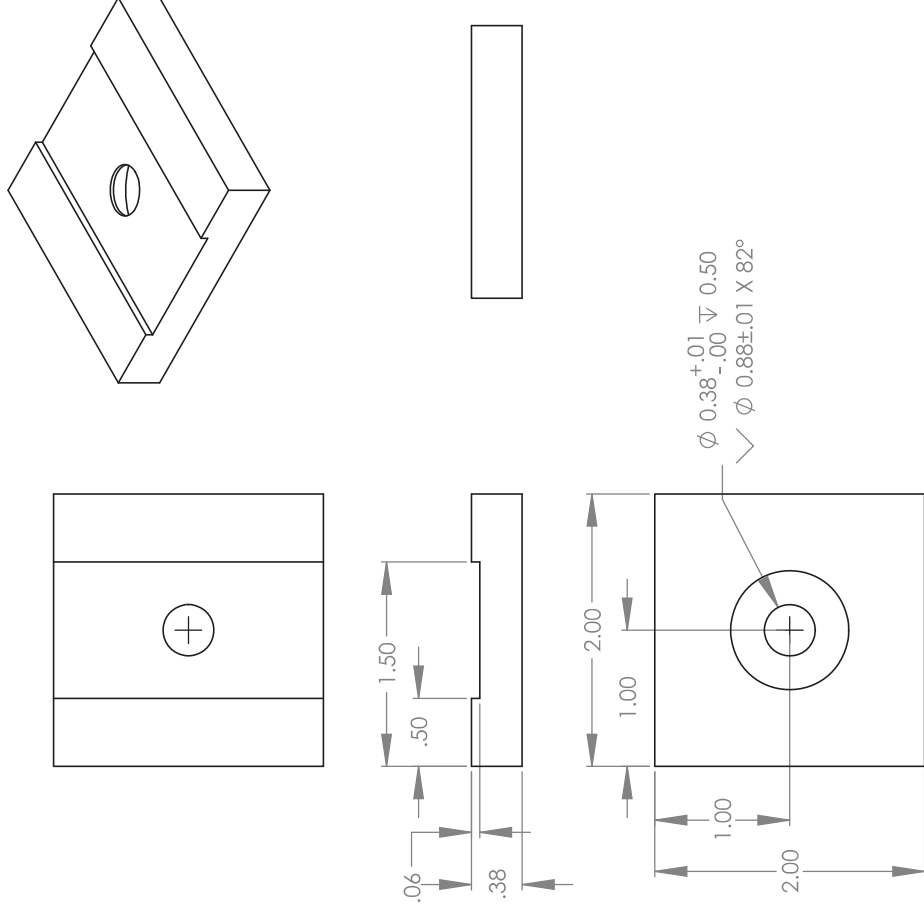

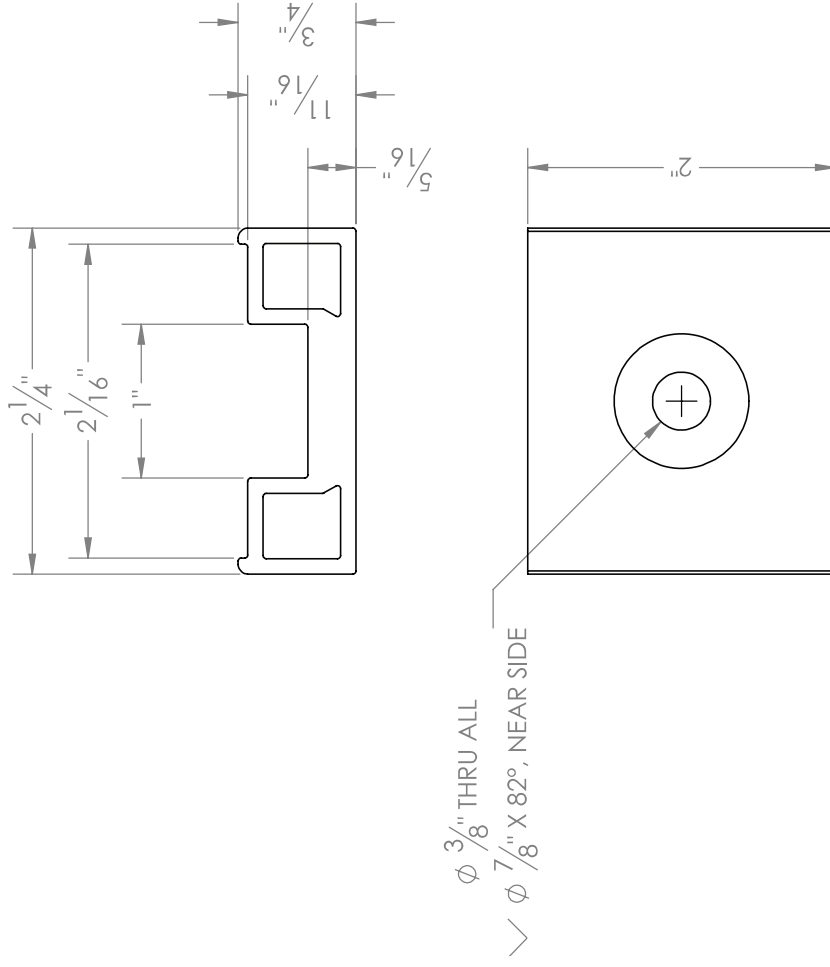

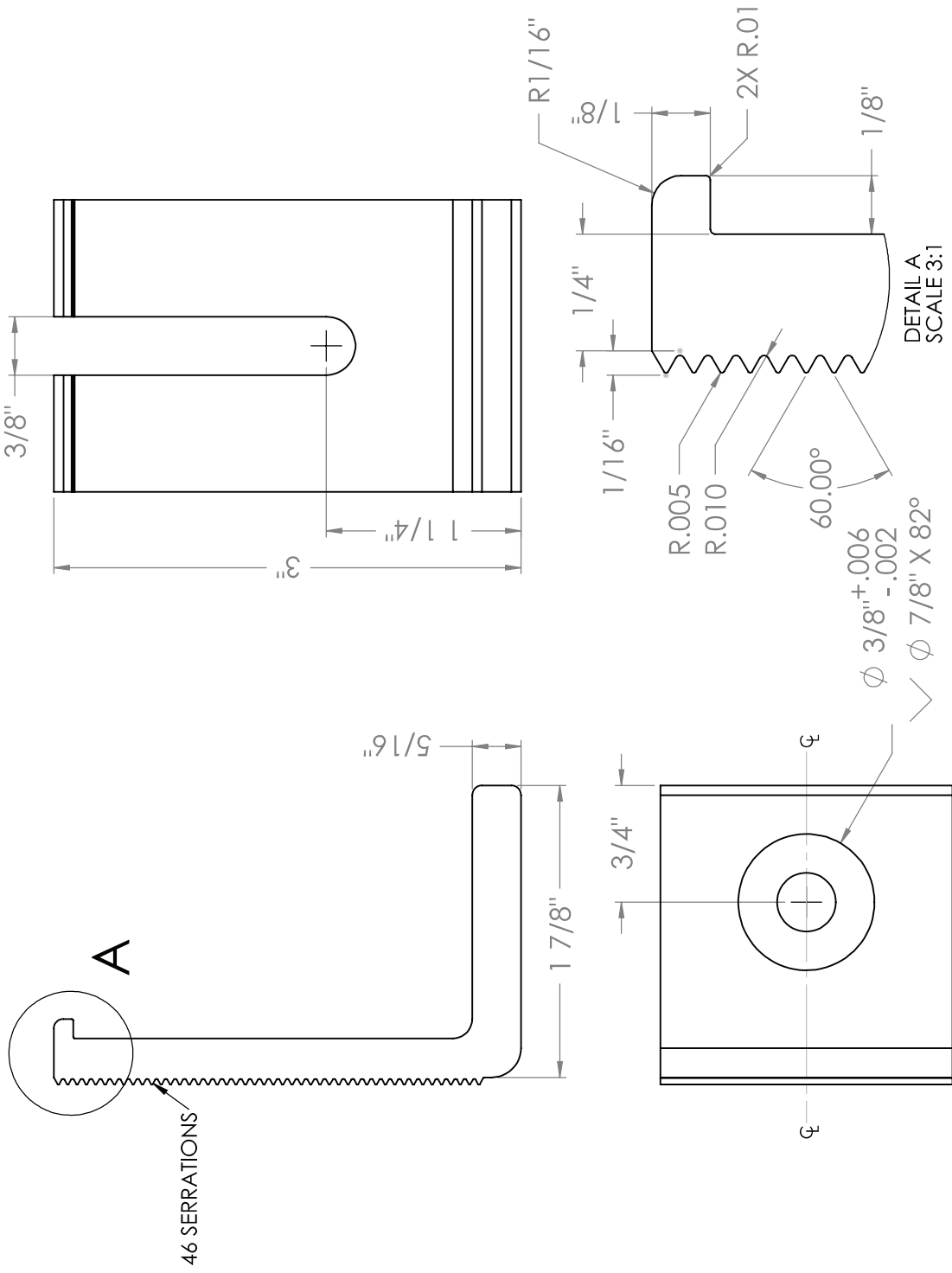

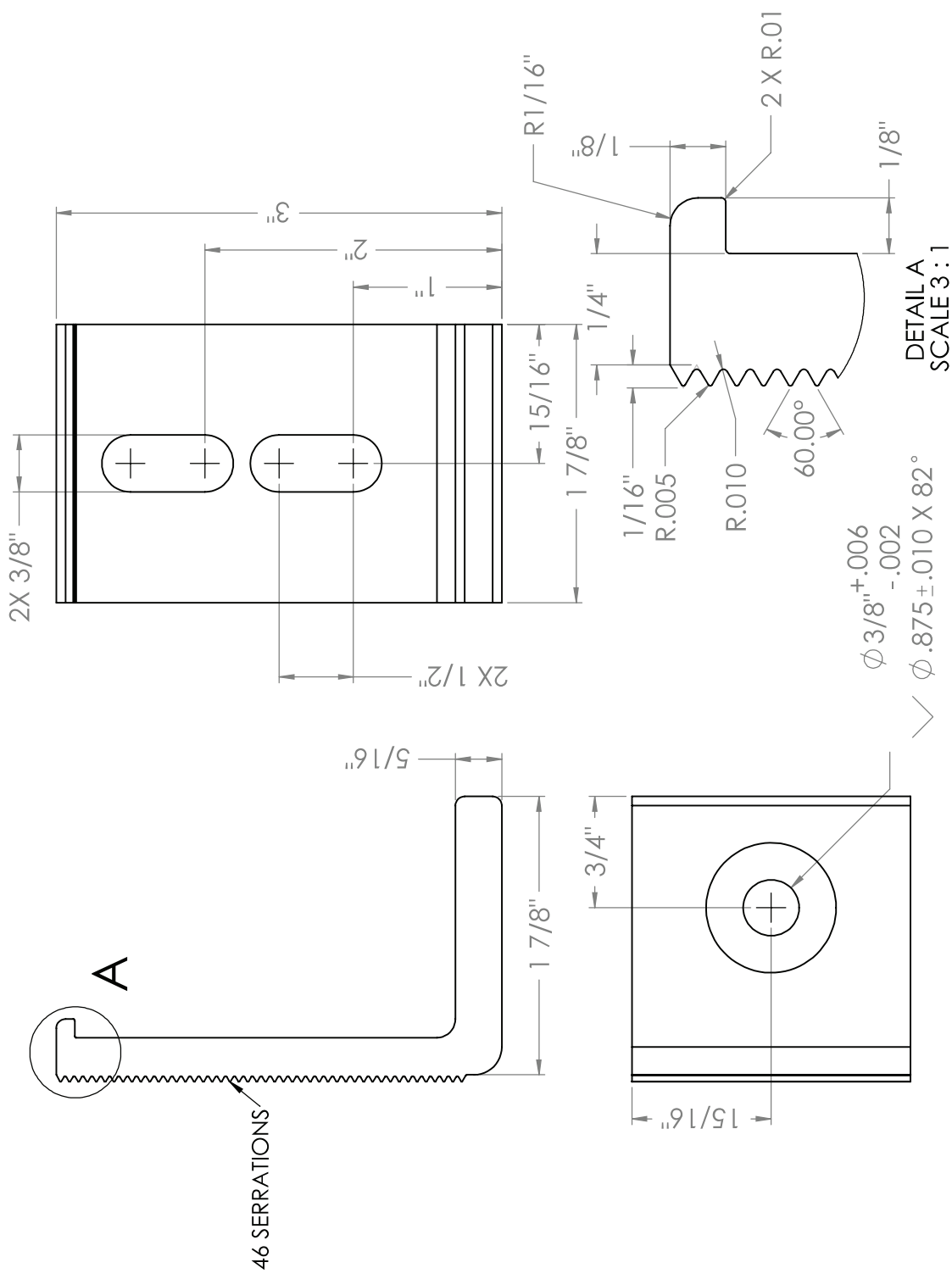

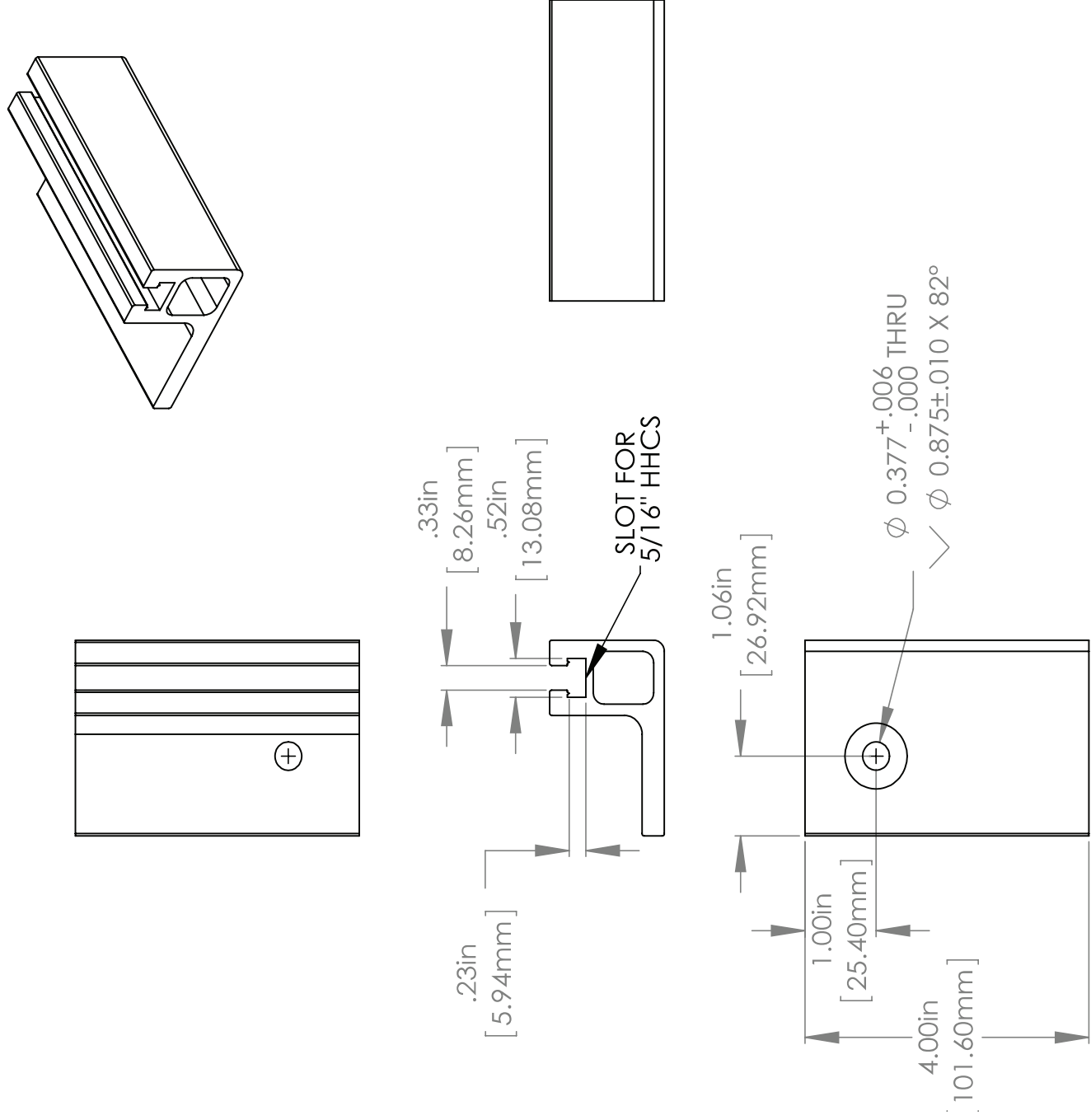

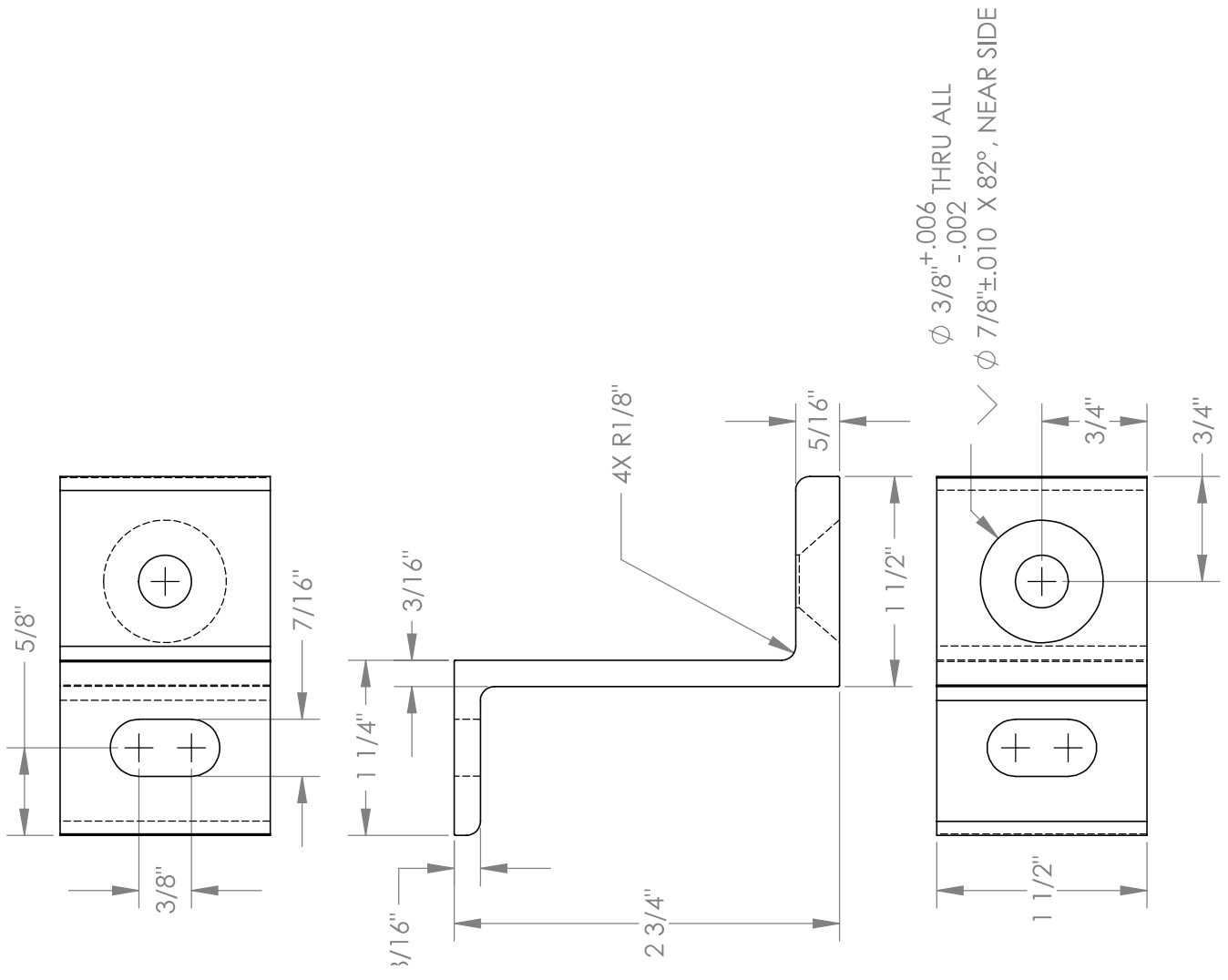

PART 1 – GENERAL**1.1 SUMMARY**

- A. WORK INCLUDES
- GreenFasten solar attachment bracket that attaches directly to the roof deck.
 - Provide appropriate bracket and fasteners for the roof system.
- B. RELATED SECTIONS
- Section 07600: Flashing and Sheet Metal
 - Section 07500: Roofing
 - Division 1: Administrative and Procedural Requirements
 - Division 7: Thermal and Moisture Protection

1.2 SYSTEM DESCRIPTION

- A. COMPONENTS:
- GreenFasten GF1 system consists of aluminum flashing with integral EPDM bushing and one bonded stainless steel and EPDM washer.
 - Fasteners
 - To be of metal compatible with aluminum GreenFasten components.
 - Fasteners should be selected for compatibility with the roof deck.
 - Fastener strength should exceed or be equal to that of the allowable load of the system. See test data at www.ecofastensolar.com
 - Sealant (if required by roof manufacturer) to be roof manufacturer approved.
 - Aluminum compression bracket
- B. DESIGN REQUIREMENTS:
- Bracket spacing to be recommended by project engineer.
 - Install a minimum of one fastener per assembly.
 - It is important to design new structures or assess existing structures to make sure that they can withstand retained loads.

1.3 SUBMITTAL

- Submit manufacturer's written specifications.
- Submit standard product cut sheets.
- Submit installation instructions.
- Submit product specific load test data, showing ultimate and allowable load values.

1.4 QUALITY ASSURANCE

Installer to be experienced in the installation of specified roofing material for no less than 5 years in the area of the project.

1.5 DELIVERY / STORAGE / HANDLING

Inspect material upon delivery. Notify manufacturer within 24 hours of any missing or defective items. Keep material dry, covered, and off the ground until installed.

PART 2 - PRODUCTS**2.1 MANUFACTURER**

EcoFasten Solar®
289 Harrel Street, Morrisville, VT 05661
(877) 859-3947
www.ecofastensolar.com

2.2 MATERIALS

- A. Attachment Bracket
6000 Series Aluminum (choose one)
- Comp Mount Slide
 - CP-SQ-Slotted
 - F-111-A
 - L-102-3"
 - L-102-6"
 - SCL-101-3"
 - Z-101
 - Conduit Mount Bracket
- B. Fasteners (may be supplied by others) to be compatible with chosen roof application and meet specified pull out values as shown in load test data.

- Base flashing is .032 gauge aluminum embossed to accept EPDM bushing.
- Bushing is EPDM.
- Stainless steel bonded washer is 304 18.8 stainless and EPDM.

2.3 FINISH – Mill Finish

- Bracket is mill finish aluminum
- Base flashing (choose one)
 - Mill Finish
 - Black - kynar painted

PART 3 - EXECUTION**3.1 EXAMINATION**

- Substrate: Inspect structure on which brackets are to be installed and verify that it will withstand any additional loading that may be incurred.
- Notify General Contractor of any deficiencies before installing EcoFasten Solar brackets.
- Verify that roofing material has been installed correctly prior to installing solar attachment brackets.

3.2 INSTALLATION

- Comply with architectural drawings and project engineer's recommendations for location of system. Comply with Manufacturer's written installation instructions for installation and layout.





Lag pull-out (withdrawal) capacities (lbs) in typical roof lumber (ASD)

	Spe- cific Grav- ity	Lag screw specifications 5/16" shaft*	per inch thread depth
Douglas Fir, Larch	.50		266
Douglas Fir, South	.46		235
Engelmann Spruce, lodge pole Pine (MSR 1650 f & higher)	.46		235
Hem, Fir, Redwood (close grain)	.43		212
Hem, Fir (North)	.46		235
Southern Pine	.55		307
Spruce, Pine, Fir	.42		205
Spruce, Pine, Fir (E of 2 million PSI and higher grades of MSR and MEL)	.50		266

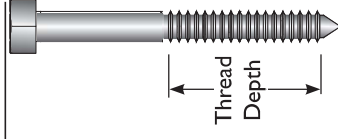

Wood Blocking Leak Test

EcoFasten Solar® tested the GreenFasten roof mount system so you can be sure your roof penetrations won't leak, even when under standing water.

Our test apparatus encapsulates the entire bracket and seals against the flashing which allows us to flood the bracket and pressurize the system.

After the apparatus is flooded it's pressurized to 30psi and left to stand for over 10 minutes. This is equivalent to nearly 70ft of standing water.



Wood Blocking Leak Test (continued)

If there were a leak, an oversized hole in the roof deck and notch in the rafter would allow unrestricted flow to two paper towels that are stuffed around the fastener. To make it clear if there was a leak, the water is dyed green.

Neither of the paper towels show any indication of leaking. The GreenFasten system is 100% water tight.





EVALUATION REPORT

Number: 216

Originally Issued: 04/15/2011

Revised: 04/13/2016

Valid Through: 04/30/2017

EVALUATION SUBJECT: GREENFASTEN-1-812, FLASHFOOT AND COMPSLIDE ROOF MOUNT ASSEMBLIES

REPORT HOLDER:

EcoFasten Solar®
IronRidge Inc.
289 Harrel Street
Morrisville, Vermont 05661
(888) 766-4273
iraan@alpacasolarguardrds.com

ADDITIONAL COMPANY NAMES:

IronRidge Inc.
1495 Zephyr Avenue
Hayward, CA 94544
(800) 227-9523
www.ironridge.com

CSI DIVISION: 06-WOOD AND PLASTICS

CSI Section: 06 25 23-Wood, Plastic, and Composite Fastenings

1.0 SCOPE OF EVALUATION

1.1 Compliance to the following codes & regulations:

- 2009 International Building Code® (IBC)
- 2009 International Residential Code® (IRC)
- 2006 International Building Code® (IBC)
- 2006 International Residential Code® (IRC)
- 1997 Uniform Building Code (UBC)-Attached Supplement

1.2 Evaluated in accordance with:

- IAPMO ES Evaluation Criteria for Joist Hangers and Miscellaneous Connectors, (EC002-2016).

1.3 Properties assessed:

- Structural
- Water Penetration

2.0 PRODUCT USE

EcoFasten Solar's and IronRidge's GreenFasten-1-812, FlashFoot and CompSlide Roof Mounts are mounting assemblies used to attach solar panels and other types of equipment to the rafters of roofs with asphalt shingle roof coverings in accordance with IBC Section 1509 and IRC Sections R905 and M2302.

3.0 PRODUCT DESCRIPTION

3.1 Product information

3.1.1 GreenFasten-1-812: The GreenFasten-1-812 Roof Mount has four basic components: aluminum flashing with

pre-installed EPDM grommet (GF-1); one-hole bracket (L-101-3); slotted bracket (SCL-101-3) or two-hole bracket (L-102-3); an EPDM bonded 18.8 washers; and a $\frac{7}{16}$ inch (7.9 mm) diameter lag screw. The published installation instructions provide more detailed dimensional information.

3.1.2 FlashFoot Roof Mount: The FlashFoot Roof Mount has five basic components: aluminum flashing with a pre-installed EPDM grommet (GF-1); a 2- $\frac{1}{2}$ inch diameter (64 mm) $\frac{5}{16}$ inch thick (7.9 mm) support disk; an EPDM bonded 18.8 washer; and a $\frac{7}{16}$ inch diameter lag screw. The published installation instructions provide more detailed dimensional information.

3.1.3 CompSlide Roof Mount: The CompSlide Roof Mount has six basic components: aluminum flashing with pre-installed EPDM grommet (GF-1); a 4 inch (102 mm) long CompSlide unit; an EPDM bonded 18.8 washers; $\frac{7}{16}$ inch (7.9 mm) diameter lag screw; one-hole bracket (L-101-3); and a $\frac{7}{16}$ inch diameter x 1- $\frac{1}{4}$ inch long (7.9 x 32 mm) Hex Head Cap Bolt with matching serrated flange nut. The published installation instructions provide more detailed dimensional information.

3.1.4 Aluminum Flashing: The aluminum flashings are made from anodized aluminum complying with ASTM B209. Table 2 of this report lists Flashings that are used with each mounting assembly.

3.2 Materials

The GreenFasten-1-812, FlashFoot and CompSlide Roof Mount components material standards are specified in Table 3 of this report.

Fasteners used to secure the flashing to the roof rafter shall be $\frac{7}{16}$ -inch-diameter (7.9 mm) lag screws complying with ANS/ASME B18.2.1-B1. The lag screw shall be long enough to penetrate the rafter a minimum of 2- $\frac{1}{2}$ inches (64 mm). Lag screws shall be corrosion-resistant. Table 1 of this report includes pull-out capacities for typical roof lumber.

4.0 DESIGN AND INSTALLATION

4.1 Design: Compliance to the following shall be provided by the Designer/Engineer if requested by the jurisdiction having authority: The tabulated allowable loads shown in this report are based on allowable stress design (ASD) and include the load duration factor, C_D , corresponding with the applicable loads in accordance with NDS.

Where the roof mounts are exposed to temperatures exceeding 100°F (37.8°C), uplift allowable loads shall be adjusted by the temperature factor, C_t , in accordance with



The product described in the Uniform Evaluation Service (UES) Report has been evaluated as an alternative material, design or method of construction in order to satisfy and comply with the intent of the provisions of the code, as noted in this report, and for at least equivalence to that prescribed in the code in quality, strength, effectiveness, the resistance, durability and safety, as applicable, in accordance with IBC, Section 104.11.

Copyright © 2016 by International Association of Plumbing and Mechanical Officials. All rights reserved. Printed in the United States. No part of this publication may be reproduced, stored in an electronic retrieval system, or transmitted, in any form or by any means, electronic, mechanical, photocopying, recording or otherwise, without the prior written permission of the publisher.

Ph: 1-877-423-6977 • Fax: 908-472-4177 • web: www.uniform-es.org • 4750 East Philadelphia Street, Ontario, California 91761-2916 – USA



EVALUATION REPORT

Number: **216**

Originally issued: **04/15/2011**

Revised: **04/13/2016**

Valid Through: **04/30/2017**

Section 10.3.4 of the NDS. When products are attached to wood framing having a moisture content greater than 19 percent (16 percent for engineered wood products), or where wet service is expected, the allowable loads shall be adjusted by the wet service factor, C_w , specified in Section 10.3.3 of the NDS. Connected wood members shall be analyzed for load-carrying capacity at the connection in accordance with the NDS.

4.2 Installation: The GreenFasten-1-812, FlashFoot and CompSlide Roof Mounts shall be installed to the rafter using one lag screw at each bracket location as described in the published installation instructions. The minimum specific gravity of the wood member shall be 0.42. The flashing shall be placed underneath the shingle far enough up slope to prevent water infiltration. Installation of GreenFasten-1-812, FlashFoot and CompSlide Roof Mounts are limited to roofs having minimum and maximum slopes of 3:12 (14 percent) and 12:12 (45 percent), respectively.

CompSlide Roof Mounts shall be installed with a maximum spacing of 1-¹/₁₆ inches (49.2 mm) center-to-center between bracket Hex Head Cap Bolts and the lag screw fastener. Hex Head Cap Bolts shall be installed a minimum of 1-¹/₁₆ inch (27 mm) on-center from the end of the CompSlide unit.

When the embossed profile on the sheet flashing lifts the shingle on the course above, the installer shall add approved caulking to the underside of the shingles on the course above.

5.0 LIMITATIONS

The GreenFasten-1-812, FlashFoot and CompSlide Roof Mounts described in this report comply with the codes listed in Section 1.0 of this report, subject to the following conditions:

5.1 The GreenFasten-1-812, FlashFoot and CompSlide Roof Mounts shall be installed in accordance with this report the manufacturer's published installation instructions, codes listed in Section 1.1 of this report and the supplement.

5.2 Calculations showing compliance with this report shall be submitted to the code official. The calculations shall be prepared by a registered design professional where required by the statutes of the jurisdiction in which the project is to be constructed.

5.3 Fasteners used in contact with fire-retardant-treated or preservative-treated lumber shall comply with IBC Section 2304.9.5 or the 2009 IRC Section R317.3 (2006 IRC Section R319.3), as applicable. The report holder or lumber treater shall be contacted for recommendations on minimum corrosion resistance and connection capacities of

fasteners used with the specific proprietary preservative-treated or fire-retardant treated lumber.

5.4 When required by the code official, a licensed design professional shall provide calculations to verify that imposed loads on the assembly do not exceed the allowable loads contained in Table 1 of this report.

5.5 When required by the code official, a licensed design professional shall provide calculations for the assembly support framing.

6.0 SUBSTANTIATING DATA

Testing and analysis data submitted is in conformance with IAPMO ES Evaluation Criteria for Joist Hangers and Miscellaneous Connectors, (EC002-2016). Rain test data is in conformance with the Underwriters Laboratory Standard for Gas Vents, (UL 441-96 Section 25). Test results are from laboratories in compliance with ISO/IEC 17025.

7.0 IDENTIFICATION

EcoFasten Solar's and IronKidge's, GreenFasten-1-812, FlashFoot and CompSlide Roof Mounts are identified with a label bearing the Manufacturer's name and address, product designation, IAPMO Uniform ES Marks of Conformity, this evaluation report number (ER-216), compliance code, and inspection agency.

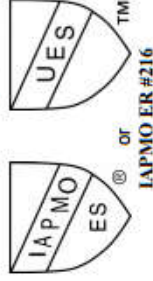

Brian Gerber
Brian Gerber, P.E., S.E.
 Vice President, Technical Operations
 Uniform Evaluation Service

Richard Beck
Richard Beck, PE, CBO, MCP
 Vice President, Uniform Evaluation Service
Russ Chanev
GP Russ Chanev
 CEO, The IAPMO Group

For additional information about this evaluation report please visit
www.iapmo.com/ues or email at iafes@iapmo.com



EVALUATION REPORT

Number: **216**

Originally issued: 04/15/2011 Revised: 04/13/2016 Valid Through: 04/30/2017



Table 1: Allowable Load (pounds)

Load Direction	Bracket ¹	Specific Gravity of Lumber	Flashing	
			GreenFasten-1-812	FlashFoot
Based on Tested Ultimate²				
Uplift	L-101-3	0.52	741	N/A
	L-102-3	0.42	653	717
	SCL-101-3	0.47	604	717
	CompSlide	0.42	668	N/A
Lateral	L-101-3	0.52	298	N/A
	L-102-3	0.42	304	339
	SCL-101-3	0.47	273	339
	CompSlide	0.42	221	N/A
Based on Load at 1/8" Deflection³				
Uplift	L-101-3	0.52	1293	N/A
	L-102-3	0.42	1356	414
	SCL-101-3	0.47	1926	414
	CompSlide	0.42	98	N/A
Lateral	L-101-3	0.52	320	N/A
	L-102-3	0.42	293	168
	SCL-101-3	0.47	401	168
	CompSlide	0.42	85	N/A

For SE, 1 lb. force = 4.448 N, 1 inch = 25.4 mm.
 1. Brackets are shown in Figures 2, 5 and 6 of this report
 2. Lowest value of tested samples divided by factor-of-safety.
 3. Average load of tested samples at 1/8-inch deflection.



EVALUATION REPORT

Number: **216**

Originally issued: 04/15/2011 Revised: 04/13/2016 Valid Through: 04/30/2017

Table 2: Assembly Models and Installation

Model/Assembly	Flashing(s) ¹	Bracket(s)/mounting hardware	Fastener
GreenFasten-812	Flat 8" x 12" (GF1-XXX-812); GF1-XXX-812-U; GF1-XXX-812-Peak; GF1-XXX-812-ARC; GF1-XXX-812-Ridges; or GF1-XXX-812-Lines-6.0	One-hole bracket (L-101-3); or Slotted bracket (SCI-101-3); or Two-hole bracket (L-102-3)	5/16" diameter lag screw
FlashFoot Mount²	Formed 12" x 12" with raised circular center	2.5" diameter x 5/16" thick support disk and One-hole bracket (L-101-3)	5/16" diameter lag screw
CompSlide Mount²	Flat 8" x 12"; GF1-XXX-812-U; GF1-XXX-812-Peak; GF1-XXX-812-ARC; GF1-XXX-812-Ridges; or GF1-XXX-812-Lines-6.0	4" long CompSlide mounting unit and: One-hole bracket (L-101-3); or Slotted bracket (SCI-101-3); or Two-hole bracket (L-102-3)	5/16" diameter lag screw; and 5/16" diameter x 1-1/4" long hex-head cap bolt with matching serrated flange nut

¹ All flashing systems come with an EPDM bonded 18.8 grommet mounted in the center

² Includes an EPDM bonded 18.8 washer

³ Install with approved sealant under the exposed tab of asphalt shingles.

Table 3: Material Properties

Hex Lag screw	ANSI/ASME B18.2.1-B1 see table 12 QSM for pull out capacities for typical roof lumber (ADS)	Figure 1
Aluminum Bracket	AAS-6061	Figure 2, 5 & 6
EPDM Metal roof bushing (washer)	Type 304 stainless steel complying with ASTM A 240	Figure 3
EPDM Grommet	ASTM D412, D297, D2240, and ASTM D624, with a durometer rating of 60	Figure 4
Flashing	ASTM B-209	Figure 4
Aluminum Support Plate		Figure 8
CompSlide	AAS 6061	Figure 9





EVALUATION REPORT

Number: 216

Originally Issued: 04/15/2011 Revised: 04/13/2016 Valid Through: 04/30/2017

Load Orientation/Direction Detail

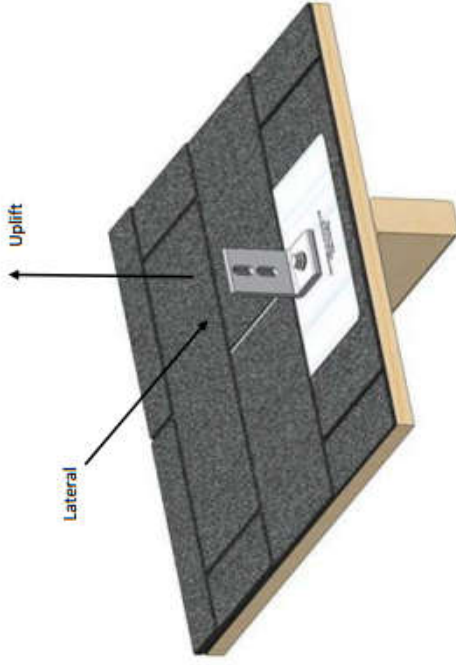

Building Green with EcoFasten Solar®





EVALUATION REPORT

Number: 216

Originally Issued: 04/15/2011

Revised: 04/13/2016

Valid Through: 04/30/2017

EcoFasten Solar Components



Figure 1:
Lag Screw

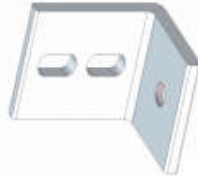

Figure 2: L-102-3



Figure 4:
GreenFast
en-1-812
Flashing
with
EPDM



Figure 3:
EPDM
Metal
roof
bushing



Figure 5: L-101-3



Figure 6: SCL-101-3



Figure 7: FlashFoot Flashing



Figure 8: Aluminum Support Plate



Figure 9: CompSlide Roof Mount Assembly



EVALUATION REPORT

Number: 216

Originally Issued: 04/15/2011

Revised: 04/13/2016

Valid Through: 04/30/2017



EVALUATION REPORT

Number: **216**

Originally issued: 04/15/2011

Revised: 04/13/2016

Valid Through: 04/30/2017

Figure 10: Flashings

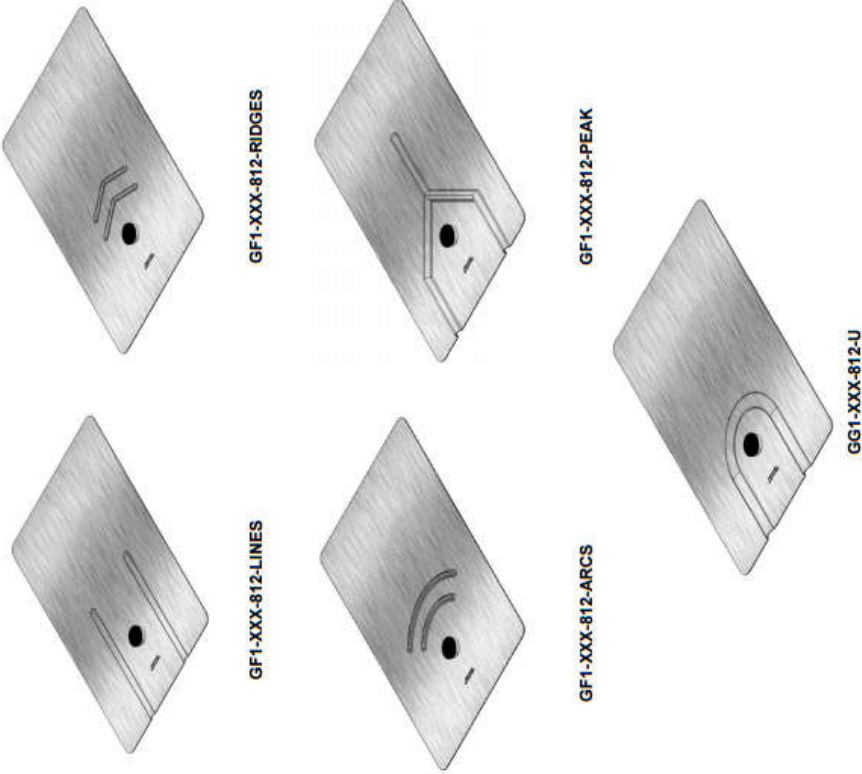

EVALUATION REPORT

Number: **216**

Originally issued: 04/15/2011

Revised: 04/13/2016

Valid Through: 04/30/2017

UBC SUPPLEMENT

EVALUATION SUBJECT:
GREENFASTEN-1-812, FLASHFOOT AND
COMPSLIDE ROOF MOUNT ASSEMBLIES

REPORT HOLDER:

EcoFasten Solar[®]
289 Harrel Street
Morrisville, Vermont 05661
Phone: 888-766-4273
brian@alpinenowguards.com

ADDITIONAL COMPANY NAMES:

IronRidge Inc.
1495 Zephyr Avenue
Hayward, CA 94544
(800) 227-9523
www.ironridge.com

CSI DIVISION: 06—WOOD AND PLASTICS
CSI Section: 06 25 23—Wood, Plastic, and
Composite Fastenings

1.0 EVALUATION SCOPE

1.1 Compliance with the following codes

- 1997 Uniform Building Code (UBC)

2.0 FINDINGS

The Greenfasten-1-812, Flashfoot and Compslide Roof Mount Assemblies described in IAPMO UES Evaluation Report ER-216 comply with the codes listed in Section 1.1 of this supplement. Use, design, and installation shall be in accordance with ER-216.

3.0 SUBSTANTIATING DATA

Testing and analysis data submitted is in conformance with IAPMO ES Evaluation Criteria for Joist Hangers and Miscellaneous Connectors, (EC002-2011). Rain test data is in conformance with the Underwriters Laboratory Standard for Gas Vents, (UL 441-96 Section 15). Test results are from laboratories in compliance with ISO/IEC 17025.

For additional information about this evaluation report please visit www.uesfasten.com or email at info@uesfasten.com

Enphase IQ 7 and IQ 7+ Microinverters

The high-powered smart grid-ready **Enphase IQ 7 Micro™** and **Enphase IQ 7+ Micro™** dramatically simplify the installation process while achieving the highest system efficiency.

Part of the Enphase IQ System, the IQ 7 and IQ 7+ Microinverters integrate with the Enphase IQ Envoy™, Enphase IQ Battery™, and the Enphase Enlighten™ monitoring and analysis software.

IQ Series Microinverters extend the reliability standards set forth by previous generations and undergo over a million hours of power-on testing, enabling Enphase to provide an industry-leading warranty of up to 25 years.

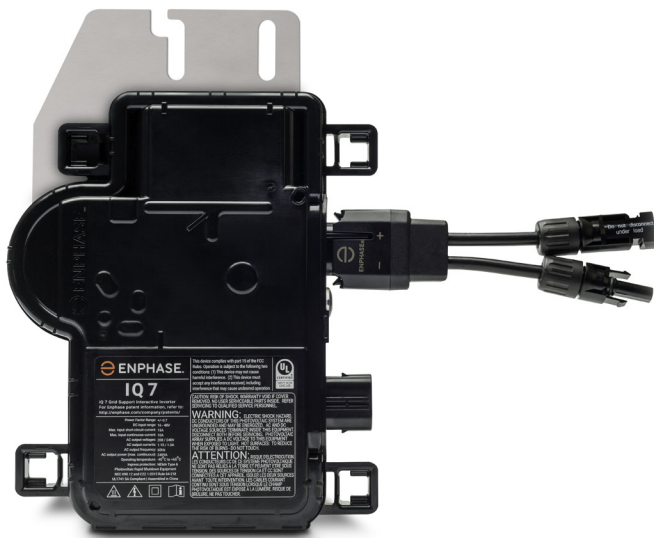

Easy to Install

- Lightweight and simple
- Faster installation with improved, lighter two-wire cabling
- Built-in rapid shutdown compliant (NEC 2014 & 2017)

Productive and Reliable

- Optimized for high powered 60-cell/120 half-cell and 72-cell/144 half-cell* modules
- More than a million hours of testing
- Class II double-insulated enclosure
- UL listed

Smart Grid Ready

- Complies with advanced grid support, voltage and frequency ride-through requirements
- Remotely updates to respond to changing grid requirements
- Configurable for varying grid profiles
- Meets CA Rule 21 (UL 1741-SA)

* The IQ 7+ Micro is required to support 72-cell/144 half-cell modules.



Enphase IQ 7 and IQ 7+ Microinverters

INPUT DATA (DC)	IQ7-60-2-US		IQ7PLUS-72-2-US	
Commonly used module pairings ¹	235 W - 350 W +		235 W - 440 W +	
Module compatibility	60-cell/120 half-cell PV modules only		60-cell/120 half-cell and 72-cell/144 half-cell PV modules	
Maximum input DC voltage	48 V		60 V	
Peak power tracking voltage	27 V - 37 V		27 V - 45 V	
Operating range	16 V - 48 V		16 V - 60 V	
Min/Max start voltage	22 V / 48 V		22 V / 60 V	
Max DC short circuit current (module I _{sc})	15 A		15 A	
Overvoltage class DC port	II		II	
DC port backfeed current	0 A		0 A	
PV array configuration	1 x 1 ungrounded array; No additional DC side protection required; AC side protection requires max 20A per branch circuit			
OUTPUT DATA (AC)	IQ 7 Microinverter		IQ 7+ Microinverter	
Peak output power	250 VA		295 VA	
Maximum continuous output power	240 VA		290 VA	
Nominal (L-L) voltage/range ²	240 V / 211-264 V	208 V / 183-229 V	240 V / 211-264 V	208 V / 183-229 V
Maximum continuous output current	1.0 A (240 V)	1.15 A (208 V)	1.21 A (240 V)	1.39 A (208 V)
Nominal frequency	60 Hz		60 Hz	
Extended frequency range	47 - 68 Hz		47 - 68 Hz	
AC short circuit fault current over 3 cycles	5.8 Arms		5.8 Arms	
Maximum units per 20 A (L-L) branch circuit ³	16 (240 VAC)	13 (208 VAC)	13 (240 VAC)	11 (208 VAC)
Overvoltage class AC port	III		III	
AC port backfeed current	18 mA		18 mA	
Power factor setting	1.0		1.0	
Power factor (adjustable)	0.85 leading ... 0.85 lagging		0.85 leading ... 0.85 lagging	
EFFICIENCY	@240 V	@208 V	@240 V	@208 V
Peak efficiency	97.6 %	97.6 %	97.5 %	97.3 %
CEC weighted efficiency	97.0 %	97.0 %	97.0 %	97.0 %
MECHANICAL DATA				
Ambient temperature range	-40°C to +65°C			
Relative humidity range	4% to 100% (condensing)			
Connector type	MC4 (or Amphenol H4 UTX with additional Q-DCC-5 adapter)			
Dimensions (HxWxD)	212 mm x 175 mm x 30.2 mm (without bracket)			
Weight	1.08 kg (2.38 lbs)			
Cooling	Natural convection - No fans			
Approved for wet locations	Yes			
Pollution degree	PD3			
Enclosure	Class II double-insulated, corrosion resistant polymeric enclosure			
Environmental category / UV exposure rating	NEMA Type 6 / outdoor			
FEATURES				
Communication	Power Line Communication (PLC)			
Monitoring	Enlighten Manager and MyEnlighten monitoring options. Both options require installation of an Enphase IQ Envoy.			
Disconnecting means	The AC and DC connectors have been evaluated and approved by UL for use as the load-break disconnect required by NEC 690.			
Compliance	CA Rule 21 (UL 1741-SA) UL 62109-1, UL1741/IEEE1547, FCC Part 15 Class B, ICES-0003 Class B, CAN/CSA-C22.2 NO. 107.1-01 This product is UL Listed as PV Rapid Shut Down Equipment and conforms with NEC 2014, NEC 2017, and NEC 2020 section 690.12 and C22.1-2015 Rule 64-218 Rapid Shutdown of PV Systems, for AC and DC conductors, when installed according manufacturer's instructions.			

1. No enforced DC/AC ratio. See the compatibility calculator at <https://enphase.com/en-us/support/module-compatibility>.

2. Nominal voltage range can be extended beyond nominal if required by the utility.

3. Limits may vary. Refer to local requirements to define the number of microinverters per branch in your area.

To learn more about Enphase offerings, visit enphase.com

