



Scott E. Wyssling, PE  
Jon P. Ward, SE, PE  
Gregory T. Elvestad, PE

76 North Meadowbrook Drive  
Alpine, UT 84004  
office (201) 874-3483  
swyssling@wysslingconsulting.com

July 21, 2022

Current Insight  
2852 W. Amini Way  
South Jordan, UT 84095

Re: Engineering Services  
Carmona Residence  
30 Salisbury Lane, Spring Lake NC  
2.620 kW System

To Whom It May Concern:

We have received information regarding solar panel installation on the roof of the above referenced structure. Our evaluation of the structure is to verify the existing capacity of the roof system and its ability to support the additional loads imposed by the proposed solar system.

**A. Site Assessment Information**

1. Site visit documentation identifying attic information including size and spacing of framing for the existing roof structure.
2. Design drawings of the proposed system including a site plan, roof plan and connection details for the solar panels. This information will be utilized for approval and construction of the proposed system.

**B. Description of Structure:**

**Roof Framing:** 2 x 6 dimensional lumber spaced at 24" on center  
**Roof Material:** Composite Asphalt Shingles  
**Roof Slope:** 18 degrees  
**Attic Access:** Accessible  
**Foundation:** Permanent

**C. Loading Criteria Used**

- **Dead Load**
  - Existing Roofing and framing = 7 psf
  - New Solar Panels and Racking = 3 psf
  - TOTAL = 10 PSF
- **Live Load** = 20 psf (reducible) – 0 psf at locations of solar panels
- **Ground Snow Load** = 10 psf
- **Wind Load** based on ASCE 7-16
  - Ultimate Wind Speed = 119 mph (based on Risk Category II)
  - Exposure Category C

*Analysis performed of the existing roof structure utilizing the above loading criteria is in accordance with the 2018 North Carolina Residential Code, including provisions allowing existing structures to not require strengthening if the new loads do not exceed existing design loads by 105% for gravity elements and 110% for seismic elements. This analysis indicates that the existing framing will support the additional panel loading without damage, if installed correctly.*

**D. Solar Panel Anchorage**

1. The solar panels shall be mounted in accordance with the most recent Unirac installation manual. If during solar panel installation, the roof framing members appear unstable or deflect non-uniformly, our office should be notified before proceeding with the installation.
2. The maximum allowable withdrawal force for a  $\frac{5}{16}$ " lag screw is 235 lbs per inch of penetration as identified in the National Design Standards (NDS) of timber construction specifications. Based on a minimum penetration depth of  $2\frac{1}{2}$ ", the allowable capacity per connection is greater than the design withdrawal force (demand). Considering the variable factors for the existing roof framing and installation tolerances, the connection using one  $\frac{5}{16}$ " diameter lag screw with a minimum of  $2\frac{1}{2}$ " embedment will be adequate and will include a sufficient factor of safety.
3. Considering the wind speed, roof slopes, size and spacing of framing members, and condition of the roof, the panel supports shall be placed no greater than 72" on centers.
4. Panel supports connections shall be staggered to distribute load to adjacent framing members.

Based on the above evaluation, this office certifies that with the racking and mounting specified, the existing roof system will adequately support the additional loading imposed by the solar system. This evaluation is in conformance with the 2018 North Carolina Residential Code, current industry standards, and is based on information supplied to us at the time of this report.

Should you have any questions regarding the above or if you require further information do not hesitate to contact me.

Very truly yours,

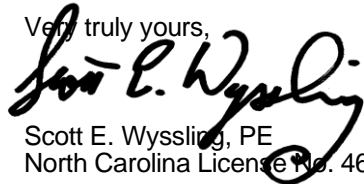

Scott E. Wyssling, PE  
North Carolina License No. 46546



**AERIAL VIEW:**

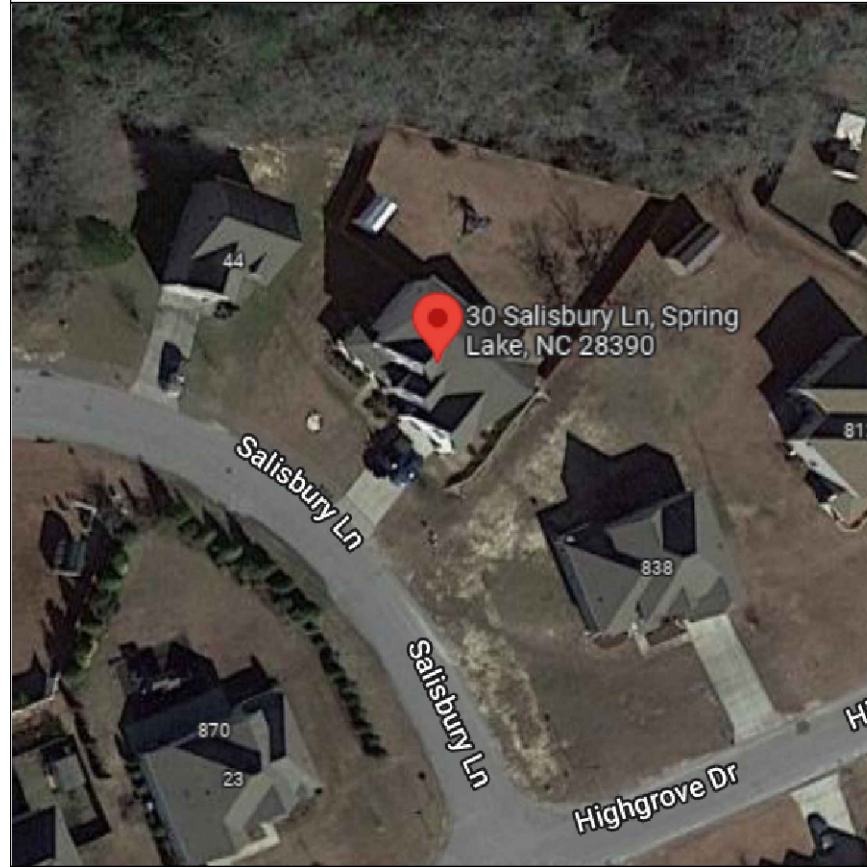

**VICINITY MAP:**

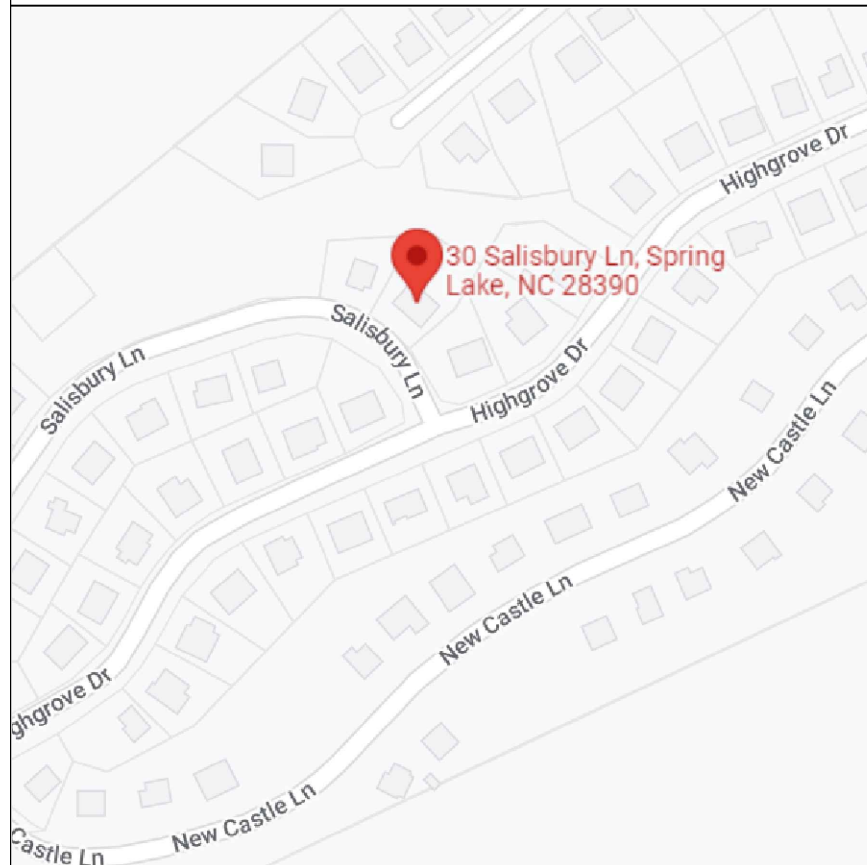

**SHEET INDEX:**

- PV-1.0 COVER SHEET
- PV-2.0 SITE PLAN
- PV-3.0 ROOF PLAN
- PV-4.0 ROOF ATTACHMENTS
- PV-5.0 MOUNTING DETAIL
- PV-6.0 SINGLE LINE DIAGRAM
- PV-7.0 LABELS
- PV-8.0 PLACARD
- PV-9.0 SITE PHOTOS

**GOVERNING CODES:**

THE INSTALLATION OF SOLAR ARRAY AND PHOTOVOLTAIC POWER SYSTEMS SHALL COMPLY WITH THE FOLLOWING CODES:

- 2020 (NEC) NATIONAL ELECTRIC CODE
- 2018 (IBC) INTERNATIONAL BUILDING CODE
- 2018 (IRC) INTERNATIONAL RESIDENTIAL CODE
- 2018 (IFC) INTERNATIONAL FIRE CODE

ALL OTHER ORDINANCE ADOPTED BY THE LOCAL GOVERNING AGENCIES

**SITE SPECIFICATIONS:**

- ZONING: RESIDENTIAL
- OCCUPANCY GROUP: R-3
- CONSTRUCTION TYPE: V-B
- NUMBER OF STORIES: 3
- ROOF LAYERS: 1
- FIRE SPRINKLERS PRESENT: N
- AHJ: HARNETT COUNTY

**GENERAL NOTES:**

1. ALL ELECTRICAL MATERIALS SHALL BE NEW AND LISTED BY RECOGNIZED ELECTRICAL TESTING LABORATORY CUSTOM MADE EQUIPMENT SHALL HAVE COMPLETE TEST DATA SUBMITTED BY THE MANUFACTURER ATTESTING TO ITS SAFETY
2. OUTDOOR EQUIPMENT SHALL BE AT LEAST NEMA 3R RATED
3. ALL METALLIC EQUIPMENT SHALL BE GROUNDED
4. ALL SPECIFIC WIRING IS BASED ON THE USE OF COPPER.
5. CONTRACTOR SHALL OBTAIN ELECTRICAL PERMITS PRIOR TO INSTALLATION AND SHALL COORDINATE ALL INSPECTIONS, TESTING COMMISSIONING AND ACCEPTANCE WITH THE CLIENT, UTILITY CO. AND CITY INSPECTORS AS NEEDED.
6. THE ELECTRICAL CONTRACTOR SHALL VERIFY THE EXACT LOCATIONS OF SERVICE POINTS AND SERVICE SIZES WITH THE SERVING UTILITY COMPANY AND COMPLY WITH ALL UTILITY COMPANIES REQUIREMENTS. IF THE SOLAR BACK FED BREAKER IS VOER THE BUSS SIZE 20% LIMIT, CONTRACTOR SHALL INCLUDE THE COST TO REPLACE MAIN BREAKER OR ENLARGE MAIN CAPACITY.
7. DRAWINGS ARE DIAGRAMMATIC ONLY, ROUTING OF RACEWAYS SHALL BE OPTION OF THE CONTRACTOR UNLESS OTHERWISE NOTED AND SHALL BE COORDINATED WITH OTHER TRADES.
8. IF THE ROOF MATERIAL OR ROOF STRUCTURE NOT ADEQUATE FOR PV INSTALLATION, CALL ENGINEER PRIOR TO INSTALL. THE CONTRACTOR IS RESPONSIBLE TO VERIFY THAT THE ROOF IS CAPABLE OF WITHSTANDING THE EXTRA WEIGHT.
9. IF THE DISTANCES FOR CABLE RUNS ARE DIFFERENT THAN SHOWN, THE CONTRACTOR SHALL NOTIFY THE ELECTRICAL ENGINEER TO VALIDATE THE SIRE SIZE. FINAL DRAWINGS WILL BE RED-LINED AND UPDATED AS APPROPRIATE.
10. WHENEVER A DISCREPANCY IN QUALITY OF EQUIPMENT ARISES ON THE DRAWING OR SPECIFICATIONS, THE CONTRACTOR SHALL BE RESPONSIBLE FOR PROVIDING AND INSTALLING ALL MATERIAL AND SERVICES REQUIRED BY THE STRICTEST CONDITIONS NOTED ON THE DRAWINGS OR IN THE SPECIFICATIONS TO ENSURE COMPLETE COMPLIANCE AND LONGEVITY OF THE OPERABLE SYSTEM REQUIRED BY THE ARCHITECT/ENGINEERS.
11. ALL BROCHURES, OPERATION MANUALS, CATALOGS, SHOP DRAWINGS, ETC. SHALL BE HANDED OVER TO OWNER'S REPRESENTATIVE AT THE COMPLETION OF WORK

**SCOPE OF WORK:**

- PV ROOF MOUNT INSTALLATION OF
- 8 TRINASOLAR TSM-360-DE06X.05(II) MODULES,
- 1 SUNNY BOY 3.0-US INVERTER(S),
- EXISTING 125A MAIN SERVICE PANEL WITH 100A MAIN
- METER CONNECTION: UNDERGROUND
- NO TRENCHING



Wyssling Consulting, PLLC  
76 N Meadowbrook Drive Alpine UT 84004  
North Carolina COA # P-2308  
Signed 7-21-22

THIS PLAN HAS BEEN ELECTRONICALLY SIGNED AND SEALED BY SCOTT WYSSLING, PE USING A DIGITAL SIGNATURE AND DATE. PRINTED COPIES OF THIS DOCUMENT ARE NOT CONSIDERED SIGNED AND SEALED AND THE SIGNATURE MUST BE VERIFIED ON ANY ELECTRONIC COPIES

**SYSTEM INFORMATION:**

- DC SYSTEM SIZE: 2.88
- MAX CONTINUOUS AC SYSTEM SIZE: 2.62
- THE EFFICIENCY FOR THE SUNNYBOY 3.0 IS .976 \* PTC 2.68 = 2.62 AC WATTS

**EQUIPMENT INFORMATION:**

- (8) TRINASOLAR TSM-360-DE06X.05(II) MODULES
- (1) SUNNY BOY 3.0-US INVERTER(S) WITH (8) JMS-F OPTIMIZERS
- MOUNTING EQUIPMENT: UNIRAC SM & UNIRAC - FLASHLOC COMP - 72" O.C.

REVIEWED BY: CT



COMPLETE SOLAR  
3000 EXECUTIVE PKWY, STE 504  
SAN RAMON, CA 94583  
LICENSE TYPE C10  
LICENSE # 961988  
PHONE # (877) 299-4943

*John S. Carf*

**CARMONA**

CHERYL CARMONA PROJECT  
30 SALISBURY LN  
SPRING LAKE, NC 28390

LAT , LONG: 35.235448,  
-78.98120689999999

**SITE INFORMATION:**

- MAX CONTINUOUS AC SYSTEM SIZE: 3
- DC SYSTEM SIZE: 2.88
- (8) TRINASOLAR TSM-360-DE06X.05(II) MODULES
- (1) SUNNY BOY 3.0-US INVERTER(S)
- MOUNTING EQUIPMENT:  
UNIRAC SM & UNIRAC - FLASHLOC COMP

DESIGNED BY: ASHLEY HAHN



DATE: July 21, 2022

**COVER SHEET**

**PV-1.0**



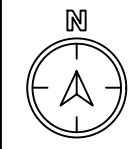

**CompleteSolar**  
A Brighter Way.

COMPLETE SOLAR  
3000 EXECUTIVE PKWY, STE 504  
SAN RAMON, CA 94583  
LICENSE TYPE C10  
LICENSE # 961988  
PHONE # (877) 299-4943

*John S. Carf*

**CARMONA**

CHERYL CARMONA PROJECT  
30 SALISBURY LN  
SPRING LAKE, NC 28390

LAT, LONG: 35.235448,  
-78.98120689999999

**SITE INFORMATION:**

MAX CONTINUOUS AC SYSTEM SIZE: 3  
DC SYSTEM SIZE: 2.88  
(8) TRINASOLAR  
TSM-360-DE06X.05(II) MODULES  
(1) SUNNY BOY 3.0-US INVERTER(S)  
MOUNTING EQUIPMENT:  
UNIRAC SM & UNIRAC - FLASHLOC  
COMP

DESIGNED BY: ASHLEY HAHN



DATE: July 21, 2022

**SITE PLAN**

**PV-2.0**



Wyssling Consulting, PLLC  
76 N Meadowbrook Drive Alpine UT 84004  
North Carolina COA # P-2308  
Signed 7-21-22

THIS PLAN HAS BEEN ELECTRONICALLY SIGNED AND SEALED BY SCOTT WYSSLING, PE USING A DIGITAL SIGNATURE AND DATE. PRINTED COPIES OF THIS DOCUMENT ARE NOT CONSIDERED SIGNED AND SEALED AND THE SIGNATURE MUST BE VERIFIED ON ANY ELECTRONIC COPIES

**EQUIPMENT LEGEND:**

- |                    |                 |                                     |                       |                |
|--------------------|-----------------|-------------------------------------|-----------------------|----------------|
| UTILITY METER      | SUBPANEL        | JUNCTION BOX                        | FIRE SETBACK (3' TYP) | PROPERTY LINE  |
| MAIN SERVICE PANEL | IQ COMBINER BOX | METER SOCKET (FOR UTILITY PV METER) | STANDOFF              | CONDUIT        |
| AC DISCONNECT      | INVERTER        | BATTERY                             | RAFTERS               | EXISTING SOLAR |
|                    |                 |                                     | RACKING RAIL          |                |

**SYSTEM RATING:**

STC = 2.88  
PTC = 2.68  
CEC = 3

ROOF AREA CALCULATIONS  
 TOTAL ROOF AREA (SQ. FT): 3113  
 SOLAR AREA (SQ. FT): 158.80  
 PERCENTAGE OF COVERED AREA: 5%

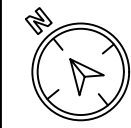

**CompleteSolar**  
 A Brighter Way.

COMPLETE SOLAR  
 3000 EXECUTIVE PKWY, STE 504  
 SAN RAMON, CA 94583  
 LICENSE TYPE C10  
 LICENSE # 961988  
 PHONE # (877) 299-4943

*John S. Carf*

**CARMONA**

CHERYL CARMONA PROJECT  
 30 SALISBURY LN  
 SPRING LAKE, NC 28390

LAT, LONG: 35.235448,  
 -78.98120689999999



Wyssling Consulting, PLLC  
 76 N Meadowbrook Drive Alpine UT 84004  
 North Carolina COA # P-2308

Signed 7-21-22

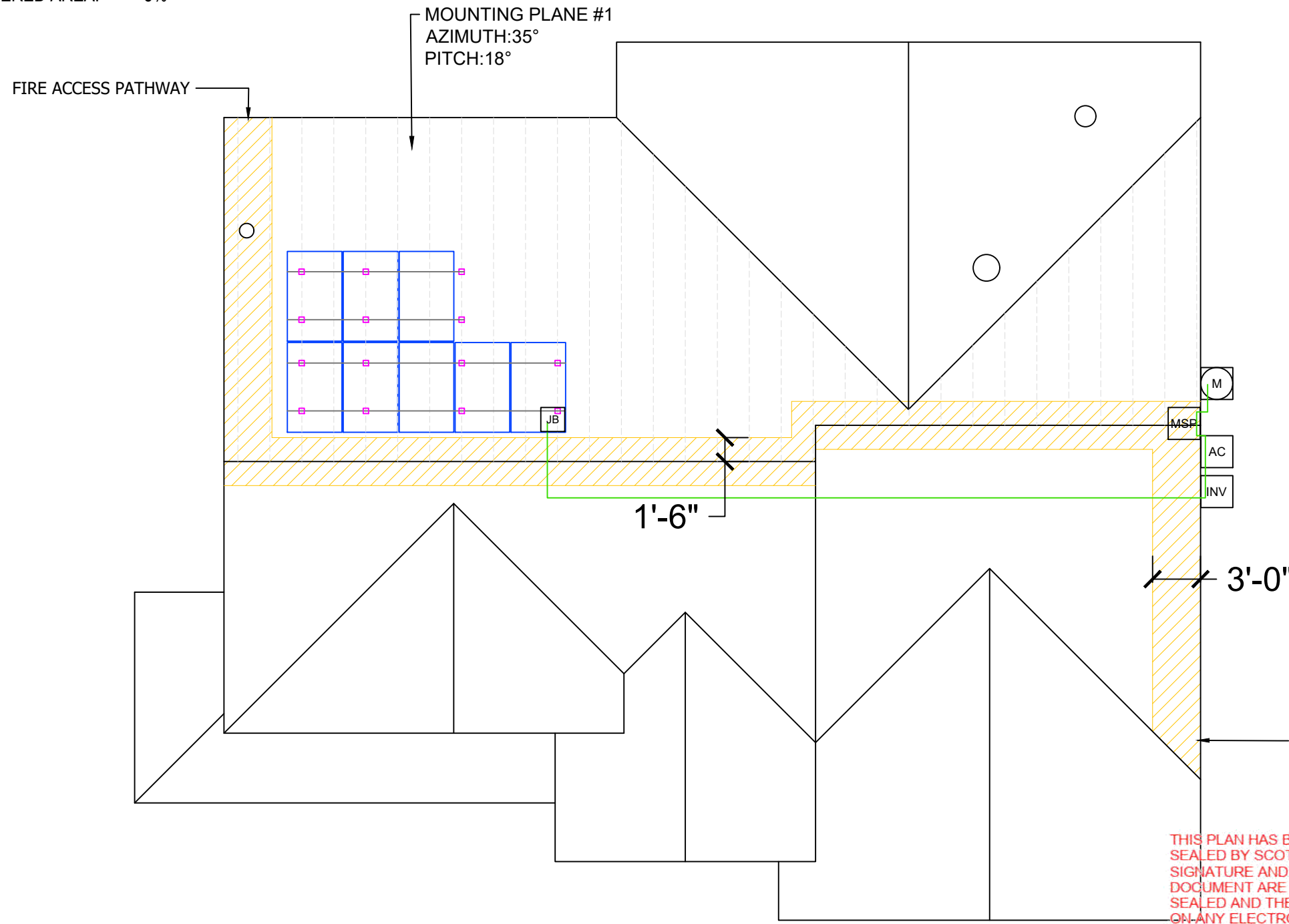

**SITE INFORMATION:**

MAX CONTINUOUS AC SYSTEM SIZE: 3  
 DC SYSTEM SIZE: 2.88  
 (8) TRINASOLAR TSM-360-DE06X.05(II) MODULES  
 (1) SUNNY BOY 3.0-US INVERTER(S)

MOUNTING EQUIPMENT:  
 UNIRAC SM & UNIRAC - FLASHLOC COMP

DESIGNED BY: ASHLEY HAHN



DATE: July 21, 2022

ROOF PLAN

**PV-3.0**

**EQUIPMENT LEGEND:**

- |                    |                 |                                     |                       |                |
|--------------------|-----------------|-------------------------------------|-----------------------|----------------|
| UTILITY METER      | SUBPANEL        | JUNCTION BOX                        | FIRE SETBACK (3' TYP) | PROPERTY LINE  |
| MAIN SERVICE PANEL | IQ COMBINER BOX | METER SOCKET (FOR UTILITY PV METER) | STANDOFF              | CONDUIT        |
| AC DISCONNECT      | INVERTER        | BATTERY                             | RAFTERS               | EXISTING SOLAR |
|                    |                 |                                     | RACKING RAIL          |                |

ASCE 7-16  
 WIND SPEED: 127 mph  
 SNOW LOAD: 10 psf

*John S. Carf*

**CARMONA**

CHERYL CARMONA PROJECT  
30 SALISBURY LN  
SPRING LAKE, NC 28390

LAT , LONG: 35.235448,  
-78.98120689999999

**SITE INFORMATION:**

MAX CONTINUOUS AC SYSTEM SIZE: 3

DC SYSTEM SIZE: 2.88

(8) TRINASOLAR  
TSM-360-DE06X.05(II) MODULES  
(1) SUNNY BOY 3.0-US INVERTER(S)

MOUNTING EQUIPMENT:  
UNIRAC SM & UNIRAC - FLASHLOC  
COMP

DESIGNED BY: ASHLEY HAHN



DATE: July 21, 2022

**ROOF ATTACHMENTS**

**PV-4.0**

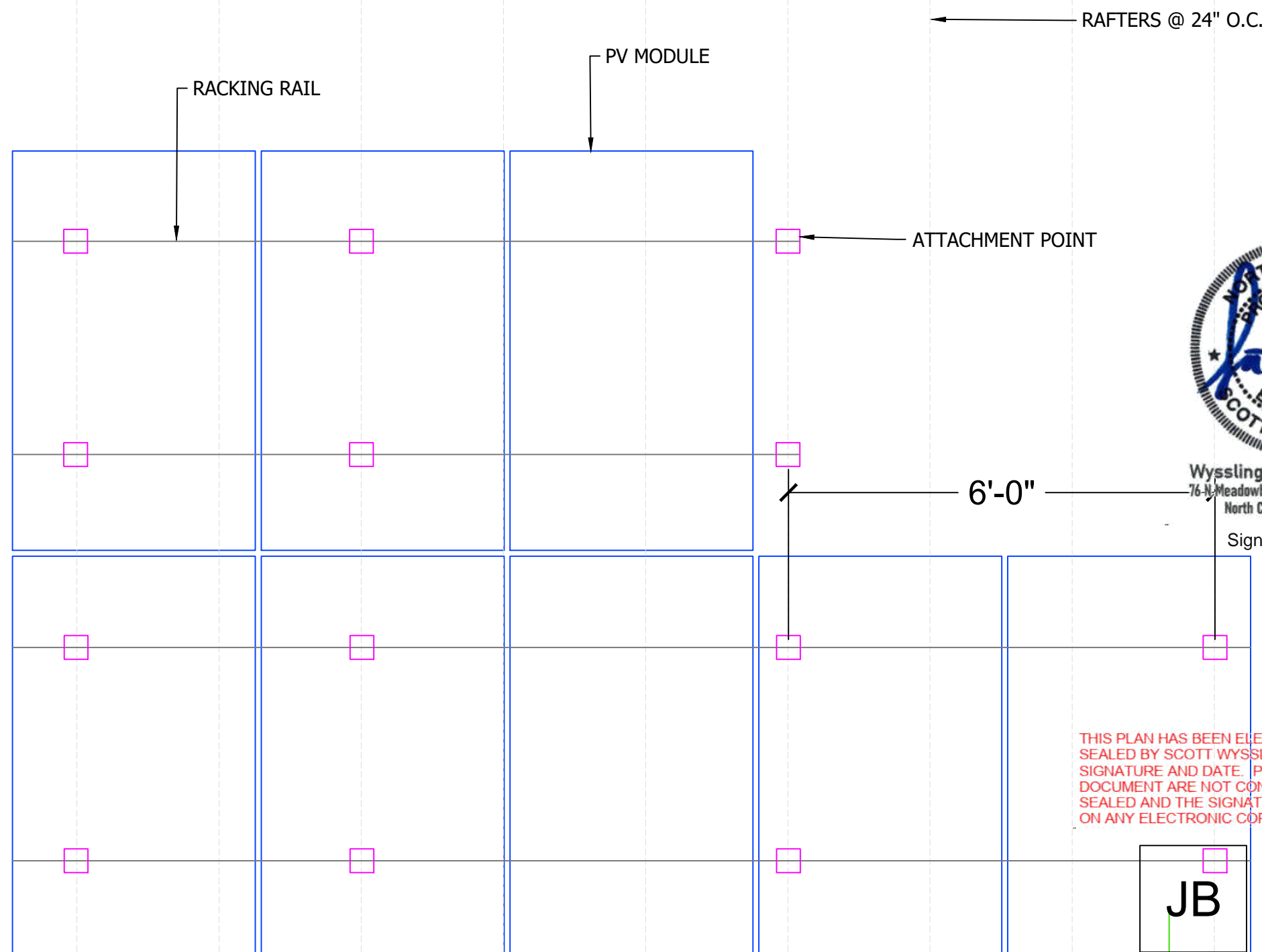

Wysling Consulting, PLLC  
76 N. Meadowbrook Drive Alpine UT 84004  
North Carolina COA # P-2308

Signed 7-21-22

THIS PLAN HAS BEEN ELECTRONICALLY SIGNED AND SEALED BY SCOTT WYSSLING, PE USING A DIGITAL SIGNATURE AND DATE. PRINTED COPIES OF THIS DOCUMENT ARE NOT CONSIDERED SIGNED AND SEALED AND THE SIGNATURE MUST BE VERIFIED ON ANY ELECTRONIC COPIES

**JB**

**PHOTOVOLTAIC ARRAY STRUCTURAL CRITERIA:**

ROOF ATTACHMENT COUNT:	14
PV MODULE COUNT:	8
ARRAY AREA:	MODULE COUNT * 19.85 = 158.8
ROOF AREA:	3113 ft <sup>2</sup>
PERCENT OF ROOF COVERED:	5%
ARRAY WEIGHT:	MODULE COUNT * 43.3lbs = 346.4
DISTRIBUTED LOAD:	ARRAY LBS/ATTACHMENTS = 24.74
POINT LOAD: (lbs/ ft <sup>2</sup> )	(ARRAY) WEIGHT/AREA = 2.18 lbs/ ft <sup>2</sup>

**MOUNTING EQUIPMENT:**

ROOF ATTACHMENT COUNT:	14
PV MODULE COUNT:	8
SPLICE COUNT:	2
MID CLAMP COUNT:	12
END CLAMP COUNT:	8
ATTACHMENT SPACING:	72" O.C.

**ROOF & FRAMING INFORMATION:**

ROOF TYPE:	Comp Shingle
FRAMING TYPE:	Rafters
RAFTER SIZE:	2x6
RAFTER SPACING:	24"

*John S. Carf*

**CARMONA**

CHERYL CARMONA PROJECT  
30 SALISBURY LN  
SPRING LAKE, NC 28390

LAT, LONG: 35.235448,  
-78.98120689999999

**SITE INFORMATION:**

MAX CONTINUOUS AC SYSTEM SIZE: 3

DC SYSTEM SIZE: 2.88

(8) TRINASOLAR  
TSM-360-DE06X.05(II) MODULES  
(1) SUNNY BOY 3.0-US INVERTER(S)

MOUNTING EQUIPMENT:  
UNIRAC SM & UNIRAC - FLASHLOC  
COMP

DESIGNED BY: ASHLEY HAHN



DATE: July 21, 2022

**MOUNTING DETAIL**

**PV-5.0**

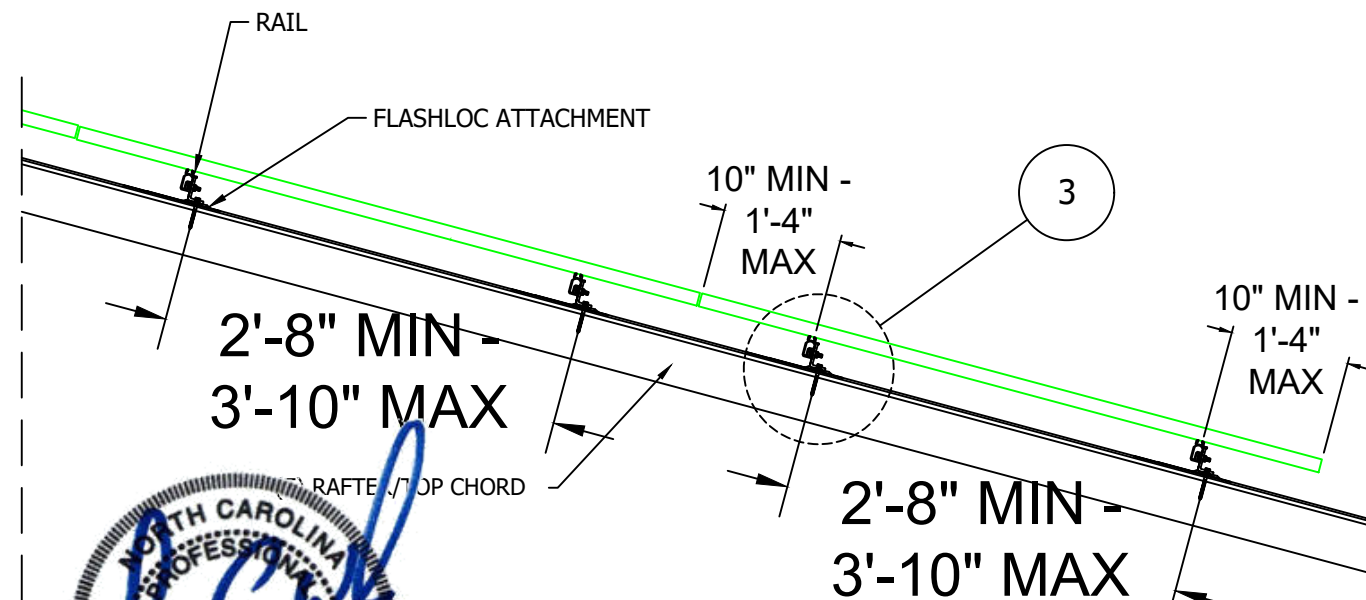
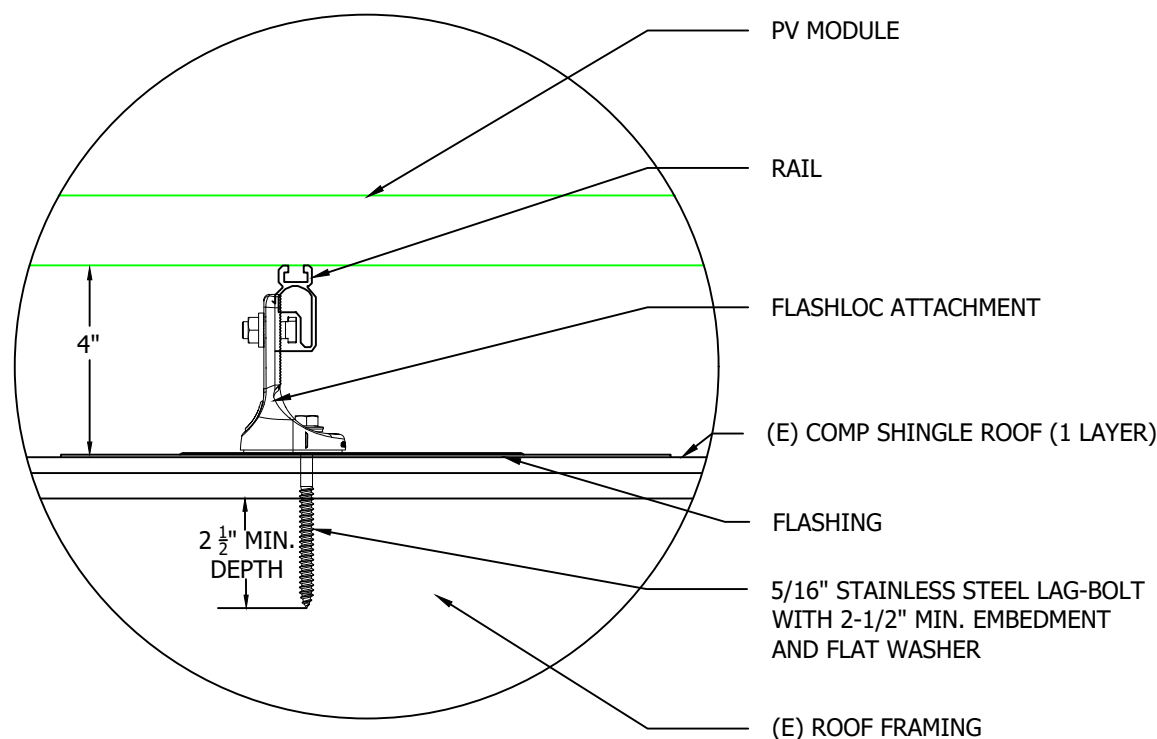

THIS PLAN HAS BEEN ELECTRONICALLY SIGNED AND SEALED BY SCOTT WYSSLING, PE USING A DIGITAL SIGNATURE AND DATE. PRINTED COPIES OF THIS DOCUMENT ARE NOT CONSIDERED SIGNED AND SEALED AND THE SIGNATURE MUST BE VERIFIED ON ANY ELECTRONIC COPIES

Wyssling Consulting, PLLC  
76 N Meadowbrook Drive Alpine UT 84004  
North Carolina COA # P-2308

Signed 7-21-22

**1 DETAIL, MOUNTING AND FLASHING**

**SIDE VIEW**

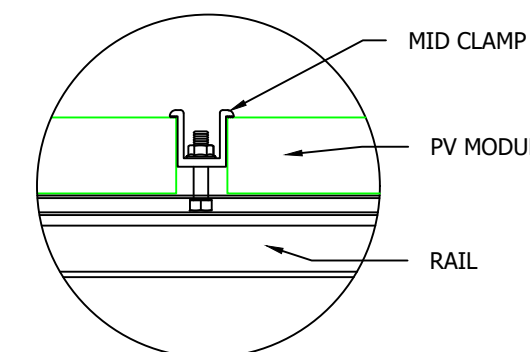
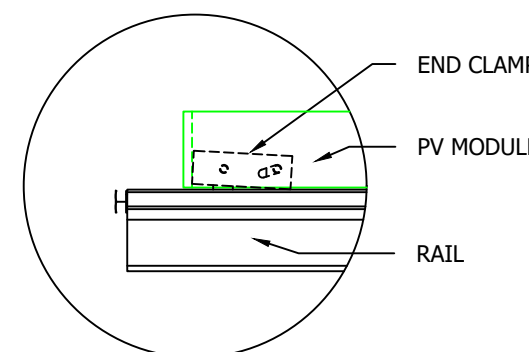
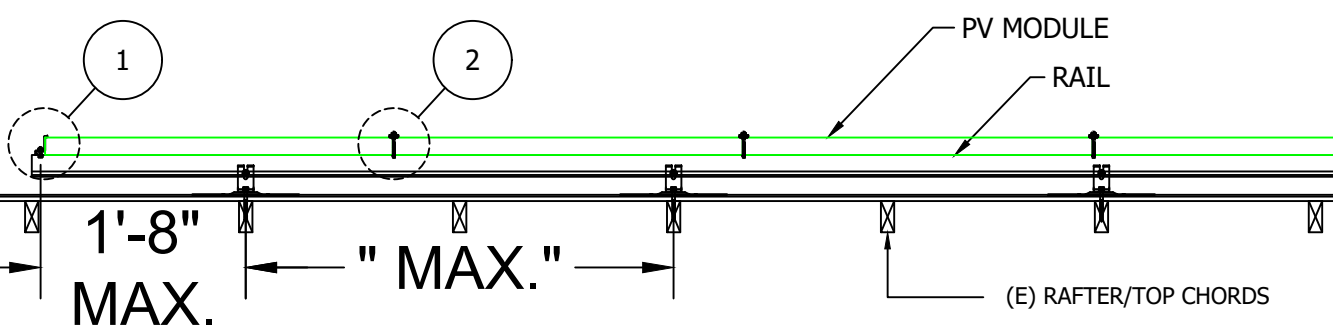

**FRONT VIEW**

**2 END CLAMP DETAILS**

**3 MID CLAMP DETAILS**

**PHOTOVOLTAIC ARRAY STRUCTURAL CRITERIA:**

**MOUNTING EQUIPMENT:**

**ROOF & FRAMING INFORMATION:**

ROOF ATTACHMENT COUNT:	14	ROOF ATTACHMENT COUNT:	14	ROOF TYPE:	Comp Shingle
PV MODULE COUNT:	8	PV MODULE COUNT:	8	FRAMING TYPE:	Rafters
ARRAY AREA:	MODULE COUNT * 19.85 = 158.8	SPLICE COUNT:	2	RAFTER SIZE:	2x6
ROOF AREA:	3113 ft <sup>2</sup>	MID CLAMP COUNT:	12	RAFTER SPACING:	24"
PERCENT OF ROOF COVERED:	5%	END CLAMP COUNT:	8		
ARRAY WEIGHT:	MODULE COUNT * 43.3lbs = 346.4	ATTACHMENT SPACING:	72" O.C.		
DISTRIBUTED LOAD:	ARRAY LBS/ATTACHMENTS = 24.74				
POINT LOAD: (lbs/ ft <sup>2</sup> )	(ARRAY) WEIGHT/AREA = 2.18 lbs/ ft <sup>2</sup>				



Wire Tag #	
1	(2) PV-WIRE - 10 AWG, USE-2, COPPER,(OR CODE APPROVED EQUIVALENT), (1) 6 AWG BARE, COPPER (GROUND)
2	(1) 10 AWG THWN - 2, OR THHN, COPPER - (POSITIVE),(1) 10 AWG THWN - 2, OR THHN, COPPER - (NEGATIVE),(1) 10 AWG THHN/THWN, COPPER - (GROUND),(1) 3/4"EMT
3	(6)10 AWG THHN/THWN-2,COPPER - (POSTIVE), (6)10 AWG THHN/THWN-2,COPPER - (NEGATIVE), (1) 10 AWG THHN/THWN-2 (GROUND), CONDUIT: 3/4" EMT
4	(1) 10 AWG THWN-2 COPPER - (L1), (1) 10 AWG THWN-2 COPPER - (L2), (1) 10 AWG THWN-2 COPPER - (NEUTRAL), (1) 10 AWG THWN-2 COPPER - (GROUND),(1) CONDUIT: 3/4" EMT

Scope of Work:	
(8) TRINASOLAR TSM-360-DE06X.05(II)	
(1) SUNNY BOY 3.0-US INVERTER(S) WITH (8) JMS-F OPTIMIZERS	
String1:	4
String2:	4
String3:	0
String4:	0
String5:	0
String6:	0

REVIEWED BY: CT



COMPLETE SOLAR  
3000 EXECUTIVE PKWY, STE 504  
SAN RAMON, CA 94583  
LICENSE TYPE C10  
LICENSE # 961988  
PHONE # (877) 299-4943

*John S. Carf*

**CARMONA**

CHERYL CARMONA PROJECT  
30 SALISBURY LN  
SPRING LAKE, NC 28390

LAT , LONG: 35.235448,  
-78.98120689999999

**SITE INFORMATION:**

MAX CONTINUOUS AC SYSTEM SIZE: 3  
DC SYSTEM SIZE: 2.88  
(8) TRINASOLAR TSM-360-DE06X.05(II) MODULES  
(1) SUNNY BOY 3.0-US INVERTER(S)  
MOUNTING EQUIPMENT:  
UNIRAC SM & UNIRAC - FLASHLOC COMP

DESIGNED BY: ASHLEY HAHN



DATE: July 21, 2022

**SINGLE LINE DIAGRAM**

**PV-6.0**

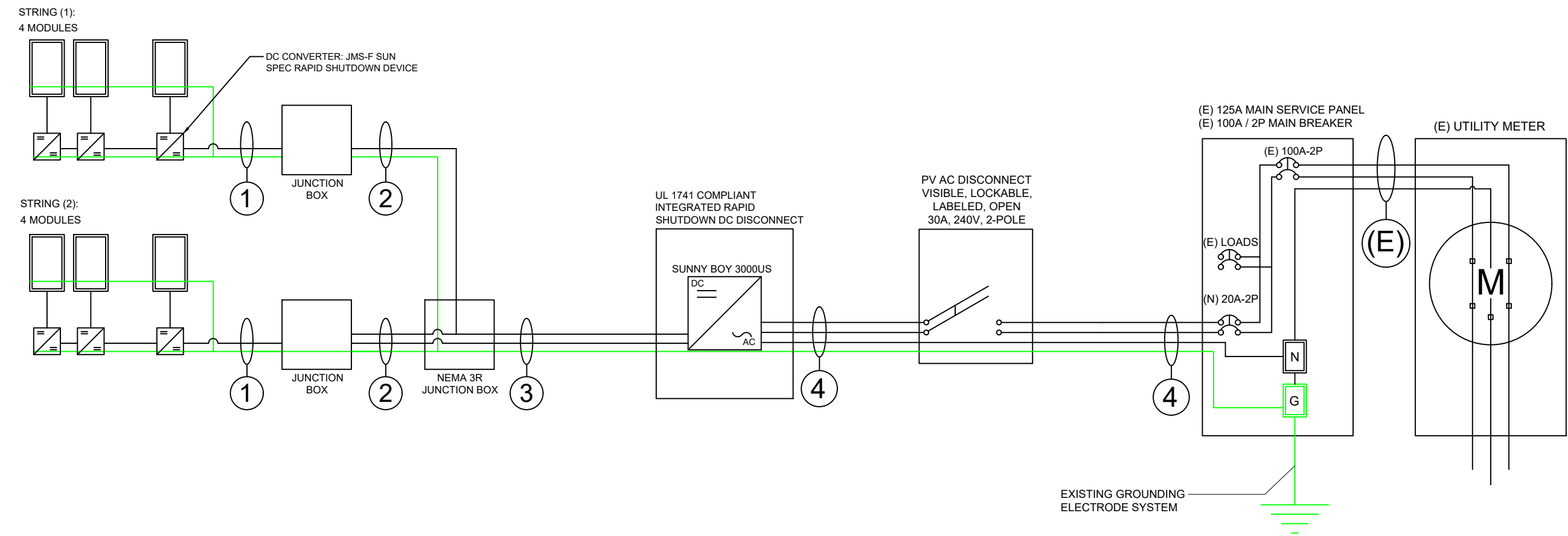

- INTERCONNECTION NOTES:**
1. INTERCONNECTION SIZING, LIMITATIONS AND COMPLIANCE DETERMINED IN ACCORDANCE WITH [NEC 705.12], AND [NEC 690.64].
  3. GROUND FAULT PROTECTION IN ACCORDANCE WITH [NEC 215.9], [NEC 230.95] AND [NEC 690.5]
  4. ALL EQUIPMENT TO BE RATED FOR BACKFEEDING.
  5. PV BREAKER TO BE POSITIONED AT THE OPPOSITE END OF THE BUSBAR RELATIVE TO THE MAIN BREAKER.

- DISCONNECT NOTES**
1. DISCONNECTING SWITCHES SHALL BE WIRED SUCH THAT WHEN THE SWITCH IS OPENED THE CONDUCTORS REMAINING LIVE ARE CONNECTED TO THE TERMINALS MARKED "LINE SIDE" (TYPICALLY THE UPPER TERMINALS)
  2. AC DISCONNECT MUST BE ACCESSIBLE TO QUALIFIED UTILITY PERSONNEL, BE LOCKABLE, AND BE A VISIBLE-BREAK SWITCH

VISIBLE, LOCKABLE,  
LABELED AC DISCONNECT  
LOCATED WITHIN 10'  
OF THE UTILITY METER



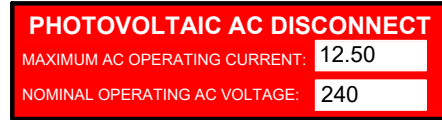

AT POINT OF INTERCONNECTION, MARKED AT DISCONNECTING MEANS [NEC 690.54]



AT POINT OF INTERCONNECTION. [NEC 705.12(D)(3)]



EACH PV SYSTEM DISCONNECTING MEANS SHALL PLAINLY INDICATE WHETHER IN THE OPEN (OFF) OR CLOSED (ON) POSITION AND BE PERMANENTLY MARKED [NEC. 690.13(B)]



AT EACH DC DISCONNECTING MEANS [NEC 690.13(B)]



AT EACH AC DISCONNECTING MEANS [NEC 690.13(B)]



AT EXPOSED RACEWAYS, CABLE TRAYS, AND OTHER WIRING METHODS; SPACED AT MAXIMUM 10FT SECTION OR WHERE SEPARATED BY ENCLOSURES, WALLS, PARTITIONS, CEILINGS, OR FLOORS [NEC 690.31(G)(3)]

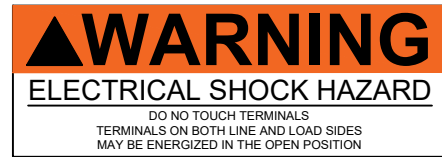

AT BUILDING OR STRUCTURE MAIN DISCONNECTING MEANS. [NEC 690.12(E), NEC 690.15]



PERMANENT WARNING LABELS SHALL BE APPLIED TO DISTRIBUTION EQUIPMENT



A PERMANENT WARNING LABEL SHALL BE APPLIED TO THE DISTRIBUTION EQUIPMENT ADJACENT TO THE BACK-FED BREAKER FROM THE INVERTER. [NEC 705.12(D)(2)(3)(b)]

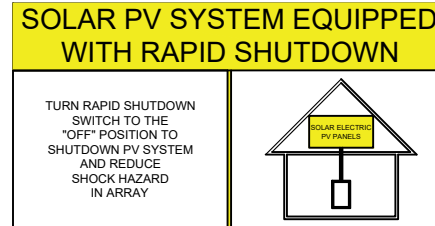

FOR PV SYSTEMS THAT SHUT DOWN THE ARRAY AND CONDUCTORS LEAVING THE ARRAY: THE TITLE "SOLAR PV SYSTEM IS EQUIPPED WITH RAPID SHUTDOWN" SHALL UTILIZE CAPITALIZED CHARACTERS WITH A MINIMUM HEIGHT OF 3/8 IN. IN BLACK ON YELLOW BACKGROUND, AND THE REMAINING CHARACTERS SHALL BE CAPITALIZED WITH A MINIMUM HEIGHT OF 3/16 IN. IN BLACK ON WHITE BACKGROUND. [NEC 690.56(C)(1)(A)]



A RAPID SHUTDOWN SWITCH SHALL HAVE A LABEL LOCATED ON OR NO MORE THAN 3 FT FROM THE SWITCH THAT INCLUDES THIS WORDING. THE LABEL SHALL BE REFLECTIVE, WITH ALL LETTERS CAPITALIZED AND HAVING A MINIMUM HEIGHT OF 3/8 IN., IN WHITE ON RED BACKGROUND. [NEC 690.56(C)(2)]



COMPLETE SOLAR  
3000 EXECUTIVE PKWY, STE 504  
SAN RAMON, CA 94583  
LICENSE TYPE C10  
LICENSE # 961988  
PHONE # (877) 299-4943

CARMONA

CHERYL CARMONA PROJECT  
30 SALISBURY LN  
SPRING LAKE, NC 28390

LAT , LONG: 35.235448,  
-78.98120689999999

SITE INFORMATION:

MAX CONTINUOUS AC SYSTEM SIZE: 3

DC SYSTEM SIZE: 2.88

(8) TRINASOLAR  
TSM-360-DE06X.05(II) MODULES  
(1) SUNNY BOY 3.0-US INVERTER(S)

MOUNTING EQUIPMENT:  
UNIRAC SM & UNIRAC - FLASHLOC  
COMP

DESIGNED BY: ASHLEY HAHN



DATE: July 21, 2022

LABELS

PV-7.0

LABELING NOTES:

1. LABELING REQUIREMENTS BASED ON THE 2020 CALIFORNIA ELECTRIC CODE, OSHA STANDARD 19010.145, ANSI Z535.
2. MATERIAL BASED ON THE REQUIREMENTS OF THE AUTHORITY HAVING JURISDICTION.
3. LABELS TO BE OF SUFFICIENT DURABILITY TO WITHSTAND THE ENVIRONMENT INVOLVED [CEC 110.21]
4. LABELS TO BE A MINIMUM LETTER HEIGHT OF 3/8", WHITE ON RED BACKGROUND; REFLECTIVE, AND PERMANENTLY AFFIXED [IFC 605.11.1.1]



**CompleteSolar**  
A Brighter Way.

COMPLETE SOLAR  
3000 EXECUTIVE PKWY, STE 504  
SAN RAMON, CA 94583  
LICENSE TYPE C10  
LICENSE # 961988  
PHONE # (877) 299-4943

*John S. Carf*

**CARMONA**

CHERYL CARMONA PROJECT  
30 SALISBURY LN  
SPRING LAKE, NC 28390

LAT , LONG: 35.235448,  
-78.98120689999999

**SITE INFORMATION:**

MAX CONTINUOUS AC SYSTEM SIZE: 3

DC SYSTEM SIZE: 2.88

(8) TRINASOLAR  
TSM-360-DE06X.05(II) MODULES  
(1) SUNNY BOY 3.0-US INVERTER(S)

MOUNTING EQUIPMENT:  
UNIRAC SM & UNIRAC - FLASHLOC  
COMP

DESIGNED BY: ASHLEY HAHN



DATE: July 21, 2022

**PLACARD**

**PV-8.0**

# CAUTION

POWER TO THIS BUILDING IS ALSO SUPPLIED  
FROM THE FOLLOWING SOURCES  
WITH DISCONNECTS LOCATED AS SHOWN:

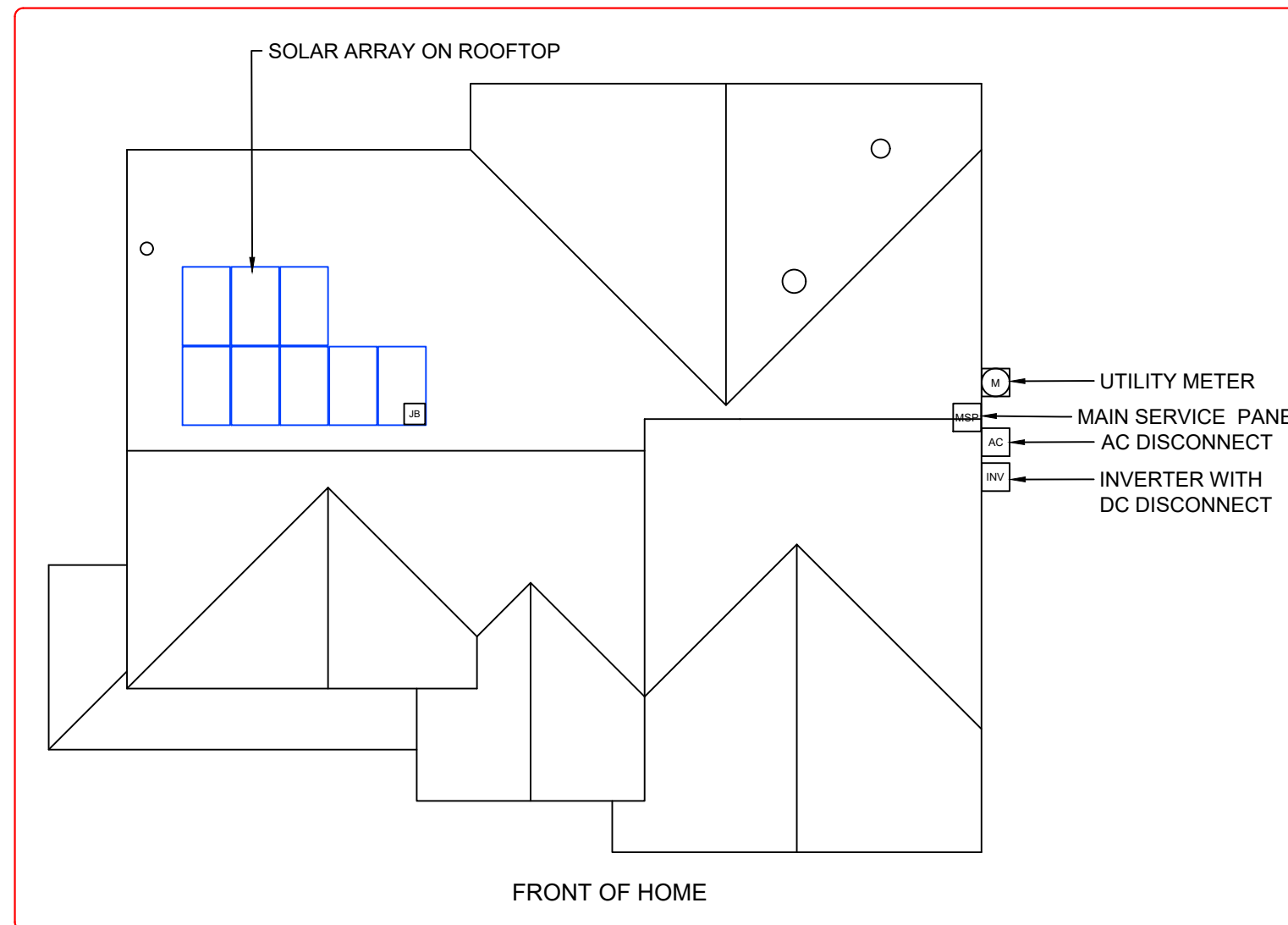

PV DISCONNECTING MEANS SHALL BE INSTALLED AT A READILY  
AVAILABLE LOCATION EITHER OUTSIDE OF A BUILDING OR STRUCTURE OR  
INSIDE THE NEAREST POINT OF ENTRANCE OF THE  
SYSTEM CONDUCTORS PER THE REQUIREMENTS OF CEC ARTICLE 690.14

# ELECTRICAL PHOTOS:

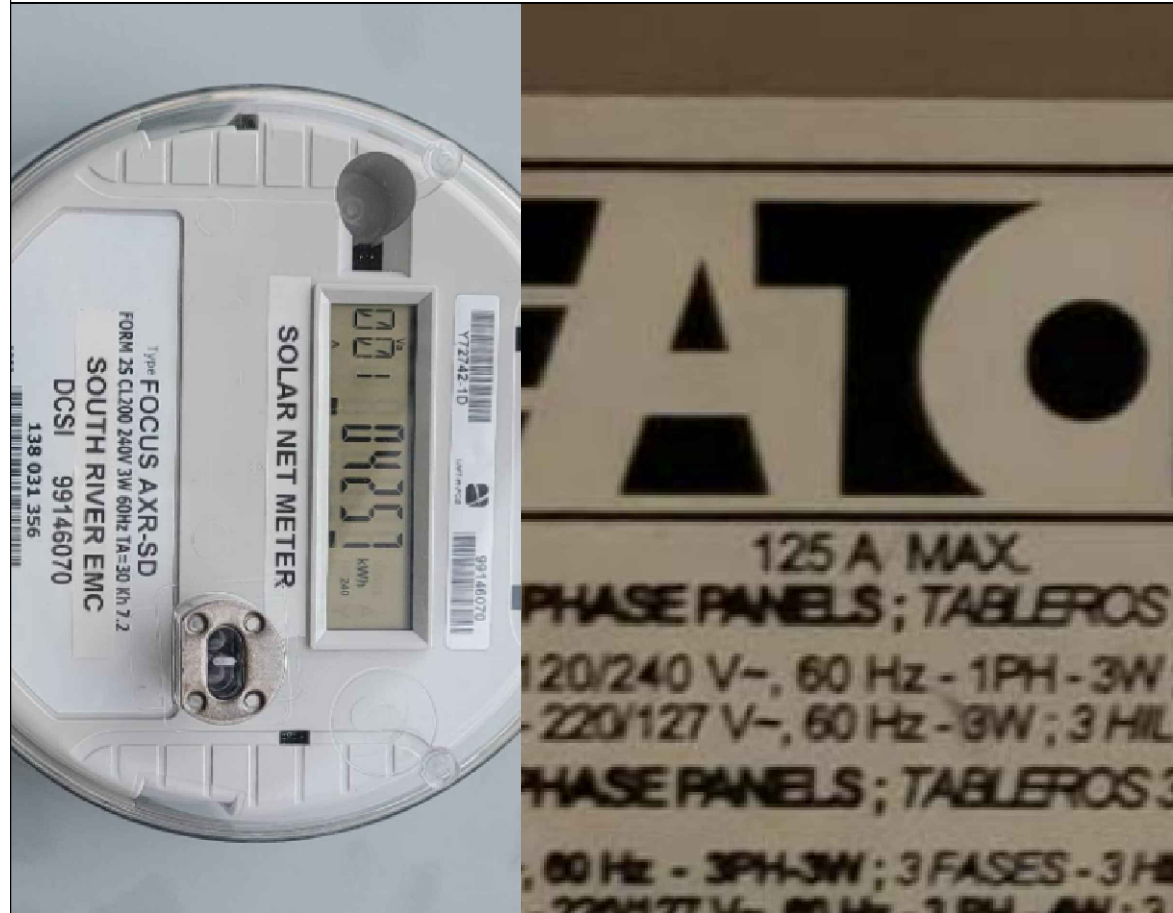

**CompleteSolar**  
A Brighter Way.

COMPLETE SOLAR  
3000 EXECUTIVE PKWY, STE 504  
SAN RAMON, CA 94583  
LICENSE TYPE C10  
LICENSE # 961988  
PHONE # (877) 299-4943

*John S. Carf*

## CARMONA

CHERYL CARMONA PROJECT  
30 SALISBURY LN  
SPRING LAKE, NC 28390

LAT, LONG: 35.235448,  
-78.98120689999999

# STRUCTURAL PHOTOS:

## SITE INFORMATION:

MAX CONTINUOUS AC SYSTEM SIZE: 3

DC SYSTEM SIZE: 2.88

(8) TRINASOLAR  
TSM-360-DE06X.05(II) MODULES

(1) SUNNY BOY 3.0-US INVERTER(S)

MOUNTING EQUIPMENT:

UNIRAC SM & UNIRAC - FLASHLOC  
COMP

DESIGNED BY: ASHLEY HAHN



DATE: July 21, 2022

## SITE PHOTOS

PV-9.0

# THE Residential Module

MULTI-BUSBAR MONO PERC MODULE

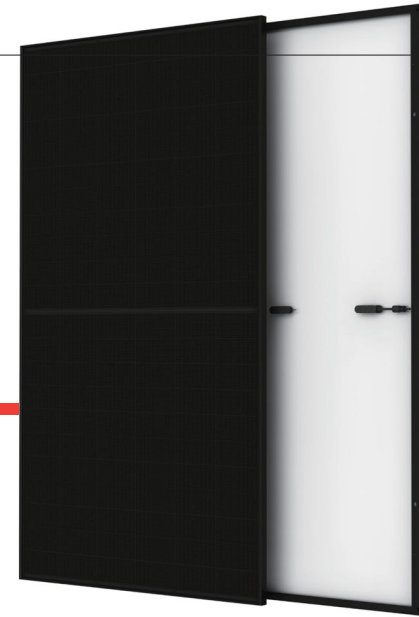

**132-Cell**  
MONOCRYSTALLINE MODULE

**355-380W**  
POWER OUTPUT RANGE

**20.6%**  
MAXIMUM EFFICIENCY

**0~+5W**  
POSITIVE POWER TOLERANCE

Founded in 1997, Trina Solar is the world's leading total solution provider for solar energy. With local presence around the globe, Trina Solar is able to provide exceptional service to each customer in each market and deliver our innovative, reliable products with the backing of Trina as a strong, bankable brand. Trina Solar now distributes its PV products to over 100 countries all over the world. We are committed to building strategic, mutually beneficial collaborations with installers, developers, distributors and other partners in driving smart energy together.

### Comprehensive Products and System Certificates

IEC61215/IEC61730/IEC61701/IEC62716/UL61730  
ISO 9001: Quality Management System  
ISO 14001: Environmental Management System  
ISO14064: Greenhouse Gases Emissions Verification  
OHSAS 18001: Occupation Health and Safety Management System



PRODUCTS | POWER RANGE  
TSM-DE06X.05(I) | 355-380W



### High power and High Efficiency

- Up to 380W front power and 20.6% module efficiency with half-cut and MBB (Multi Busbar) technology bringing more BOS savings
- Reduce BOS cost with higher power bin and 1500V system voltage



### Outstanding visual appearance

- Designed with aesthetics in mind
- High standard Production, Excellent cell color control by dedicated cell blackening treatment and machine selection
- Thinner wires that appear all black at a distance



### High reliability

- Ensured PID resistance through cell process and module material control
- Resistant to salt, acid and ammonia
- Mechanical performance: Up to 5400 Pa positive load and 2400 Pa negative load



### Certified to withstand the most challenging environmental conditions

- Excellent IAM and low light performance validated by 3rd party with cell process and module material optimization
- Lower temp co-efficient (-0.34%) and NOCT bring more energy leading to lower LCOE
- Better anti-shading performance and lower operating temperature

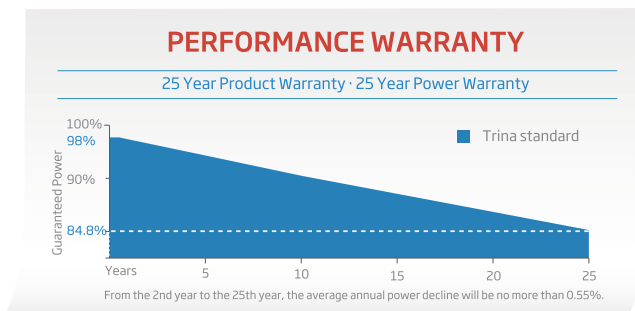

## Residential Module

MULTI-BUSBAR MONO PERC MODULE

DIMENSIONS OF PV MODULE(mm)

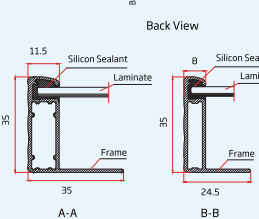
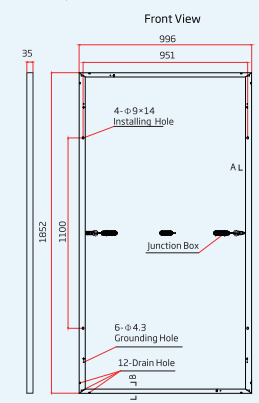
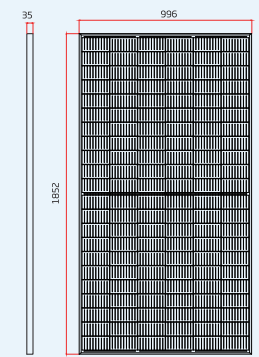

I-V CURVES OF PV MODULE(370W)

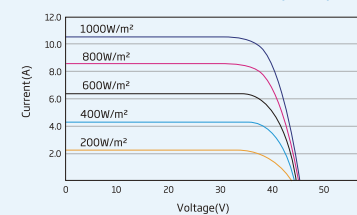

P-V CURVES OF PV MODULE(370W)

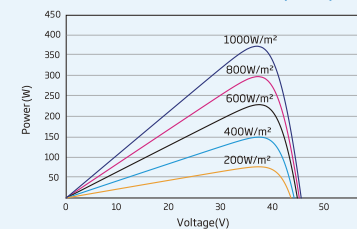

### ELECTRICAL DATA (STC)

Peak Power Watts-P <sub>MAX</sub> (Wp)*	355	360	365	370	375	380
Power Output Tolerance-P <sub>MAX</sub> (W)	0 ~ +5					
Maximum Power Voltage-V <sub>MPP</sub> (V)	36.8	37.0	37.2	37.4	37.6	37.8
Maximum Power Current-I <sub>MPP</sub> (A)	9.66	9.74	9.82	9.90	9.98	10.07
Open Circuit Voltage-V <sub>OC</sub> (V)	44.6	44.8	45.0	45.2	45.3	45.5
Short Circuit Current-I <sub>SC</sub> (A)	10.24	10.30	10.35	10.40	10.45	10.51
Module Efficiency η <sub>m</sub> (%)	19.2	19.5	19.8	20.1	20.3	20.6

STC: Irradiance 1000W/m<sup>2</sup>, Cell Temperature 25°C, Air Mass AML5.  
\*Measurement tolerance: ±3%

### ELECTRICAL DATA (NOCT)

Maximum Power-P <sub>MAX</sub> (Wp)	268	272	276	279	283	287
Maximum Power Voltage-V <sub>MPP</sub> (V)	34.4	34.7	34.9	35.1	35.3	35.6
Maximum Power Current-I <sub>MPP</sub> (A)	7.80	7.85	7.90	7.96	8.01	8.06
Open Circuit Voltage-V <sub>OC</sub> (V)	42.0	42.2	42.4	42.6	42.6	42.8
Short Circuit Current-I <sub>SC</sub> (A)	8.25	8.30	8.34	8.38	8.42	8.47

NOCT: Irradiance at 800W/m<sup>2</sup>, Ambient Temperature 20°C, Wind Speed 1m/s.

### MECHANICAL DATA

Solar Cells	Monocrystalline
Cell Orientation	132 cells
Module Dimensions	1852 × 996 × 35 mm (72.91 × 39.21 × 1.38 inches)
Weight	19.7 kg (43.4 lb)
Glass	3.2 mm (0.13 inches), High Transmission, AR Coated Heat Strengthened Glass
Encapsulant Material	EVA
Backsheet	Black-White
Frame	35 mm ( inches) Anodized Aluminium Alloy
J-Box	IP 68 rated
Cables	Photovoltaic Technology Cable 4.0mm <sup>2</sup> (0.006 inches <sup>2</sup> ), Portrait: N 280mm/P 280mm(11.02/11.02inches) Landscape: N 1400 mm /P 1400 mm (55.12/55.12 inches)
Connector	MC4 EVO2
Fire Type	Type 2

### TEMPERATURE RATINGS

NOCT(Nominal Operating Cell Temperature)	43°C (±2°C)
Temperature Coefficient of P <sub>MAX</sub>	-0.34%/°C
Temperature Coefficient of V <sub>OC</sub>	-0.25%/°C
Temperature Coefficient of I <sub>SC</sub>	0.04%/°C

### MAXIMUM RATINGS

Operational Temperature	-40~+85°C
Maximum System Voltage	1500V DC (IEC)
Max Series Fuse Rating	20A

### WARRANTY

25 year Product Workmanship Warranty  
25 year Linear Power Warranty

(Please refer to product warranty for details)

### PACKAGING CONFIGURATION

Modules per box: 31 pieces  
Modules per 40' container: 744 pieces

CAUTION: READ SAFETY AND INSTALLATION INSTRUCTIONS BEFORE USING THE PRODUCT.

© 2020 Trina Solar Limited. All rights reserved. Specifications included in this datasheet are subject to change without notice.  
Version number: TSM\_DE06X.05(I)\_NA\_2020\_PA3 [www.trinasolar.com](http://www.trinasolar.com)





# SUNNY BOY 3.0-US / 3.8-US / 5.0-US / 6.0-US / 7.0-US / 7.7-US



SB3.0-1SP-US-41 / SB3.8-1SP-US-41 / SB5.0-1SP-US-41 / SB6.0-1SP-US-41 / SB7.0-1SP-US-41 / SB7.7-1SP-US-41 / SB3.0-1TP-US-41 / SB3.8-1TP-US-41 / SB5.0-1TP-US-41 / SB6.0-1TP-US-41 / SB7.0-1TP-US-41 / SB7.7-1TP-US-41



**INTEGRATED SUNSPEC  
RAPID SHUTDOWN**



### Value-Added Improvements

- Superior integration with SMA's MLPE Power+ Solution
- World's first Secure Power Supply\* now offers up to 2,000 W
- Full grid management capabilities ensure a utility-compliant solution for any market

### Reduced Labor

- New Installation Assistant with direct access via smartphone minimizes time in the field
- Advanced communication interface with fewer components creates 50% faster setup and commissioning

### Unmatched Flexibility

- SMA's proprietary OptiTrac™ Global Peak technology mitigates shade with ease
- Multiple independent MPPTs accommodate hundreds of stringing possibilities

### Trouble-Free Servicing

- Two-part enclosure concept allows for simple, expedited servicing
- Equipped with SMA Smart Connected, a proactive service solution that is integrated into Sunny Portal

## SUNNY BOY 3.0-US / 3.8-US / 5.0-US / 6.0-US / 7.0-US / 7.7-US

Reduce costs across your entire residential business model

The residential PV market is changing rapidly. Your bottom line matters more than ever—so we've designed a superior residential solution to help you decrease costs at every stage of your business operations. The Sunny Boy 3.0-US/3.8-US/5.0-US/6.0-US/7.0-US/7.7-US join the SMA lineup of field-proven solar technology backed by the world's #1 service team, along with a wealth of improvements. Simple design, improved stocking and ordering, value-driven sales support and streamlined installation are just some of the ways that SMA helps your business operate more efficiently. And, Sunny Boy's superior integration with the innovative Power+ Solution means installers have even more flexibility in addressing their toughest challenges. Finally, SMA Smart Connected will automatically detect errors and initiate the repair and replacement process so that installers can reduce service calls and save time and money.

[www.SMA-America.com](http://www.SMA-America.com)

Technical data	Sunny Boy 3.0-US		Sunny Boy 3.8-US		Sunny Boy 5.0-US	
	208 V	240 V	208 V	240 V	208 V	240 V
<b>Input (DC)</b>						
Max. PV power	4800 W <sub>p</sub>		6144 W <sub>p</sub>		8000 W <sub>p</sub>	
Max. DC voltage	155 - 480 V		195 - 480 V		220 - 480 V	
Rated MPPT voltage range	155 - 480 V		195 - 480 V		220 - 480 V	
MPPT operating voltage range			100 - 550 V			
Min. DC voltage / start voltage			100 V / 125 V			
Max. operating input current per MPPT			10 A			
Max. short circuit current per MPPT			18 A			
Number of MPPT tracker / string per MPPT tracker			2/1		3 / 1	
<b>Output (AC)</b>						
AC nominal power	3000 W	3000 W	3330 W	3840 W	5000 W	5000 W
Max. AC apparent power	3000 VA	3000 VA	3330 VA	3840 VA	5000 VA	5000 VA
Nominal voltage / adjustable	208 V / ●	240 V / ●	208 V / ●	240 V / ●	208 V / ●	240 V / ●
AC voltage range	183 - 229 V	211 - 264 V	183 - 229 V	211 - 264 V	183 - 229 V	211 - 264 V
AC grid frequency	60 Hz / 50 Hz					
Max. output current	14.5 A	12.5 A	16.0 A	16.0 A	24.0 A	21.0 A
Power factor (cos φ)	1					
Output phases / line connections	1 / 2					
Harmonics	< 4 %					
<b>Efficiency</b>						
Max. efficiency	97.2 %	97.6 %	97.3 %	97.6 %	97.3 %	97.6 %
CEC efficiency	96.2 %	96.3 %	96.4 %	96.7 %	96.7 %	96.9 %
<b>Protection devices</b>						
DC disconnect device / DC reverse polarity protection	● / ●					
Ground fault monitoring / Grid monitoring	●					
AC short circuit protection	●					
All-pole sensitive residual current monitoring unit (RCMU)	●					
Arc fault circuit interrupter (AFCI)	●					
Protection class / overvoltage category	I / IV					
<b>General data</b>						
Dimensions (W / H / D) in mm (in)	535 x 730 x 198 (21.1 x 28.5 x 7.8)					
Packaging dimensions (W / H / D) in mm (in)	600 x 800 x 300 (23.6 x 31.5 x 11.8)					
Weight / packaging weight	26 kg (57 lb) / 30 kg (66 lb)					
Temperature range: operating / non-operating	-25 °C ... +60 °C / -40 °C ... +60 °C					
Environmental protection rating	NEMA 3R					
Noise emission (typical)	39 dB(A)					
Internal power consumption at night	< 5 W					
Topology / Cooling concept	Transformerless / Convection					
<b>Features</b>						
Ethernet ports	2					
Secure Power Supply	●*					
Display (2 x 16 characters)	●					
2.4 GHz WLAN / External WLAN antenna	●/○					
Cellular (4G / 3G) / Revenue Grade Meter	○/○**					
Warranty: 10 / 15 / 20 years	●/○/○					
Certificates and approvals	UL 1741, UL 1741 SA incl. CA Rule 21 RSD, UL 1998, UL 1699B Ed. 1, IEEE1547, FCC Part 15 (Class A & B), CAN/CSA V22.2 107.1-1, HECO Rule 14H, PV Rapid Shutdown System Equipment					
● Standard features ○ Optional features — Not available						
NOTE: US inverters ship with gray lids. Data at nominal conditions * Not compatible with the SunSpec Rapid Shutdown functionality ** Standard in SBX.X-1TP-US-41						
Type designation	SB3.0-1SP-US-41 / SB3.0-1TP-US-41		SB3.8-1SP-US-41 / SB3.8-1TP-US-41		SB5.0-1SP-US-41 / SB5.0-1TP-US-41	

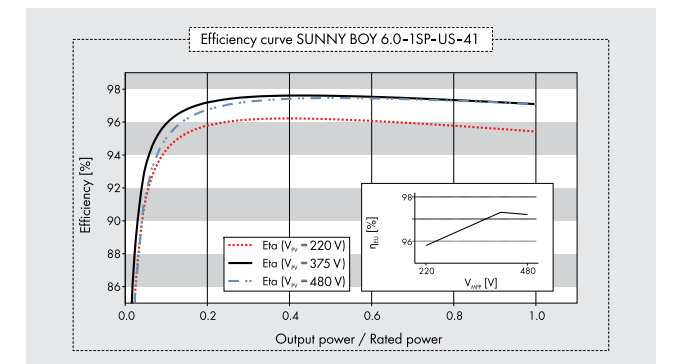

Technical data	Sunny Boy 6.0-US		Sunny Boy 7.0-US		Sunny Boy 7.7-US	
	208 V	240 V	208 V	240 V	208 V	240 V
<b>Input (DC)</b>						
Max. PV power	9600 W <sub>p</sub>		9940 W <sub>p</sub>		10905 W <sub>p</sub>	
Max. DC Voltage	600 V					
Rated MPP Voltage range	220 - 480 V		245 - 480 V		270 - 480 V	
MPPT operating voltage range	100 - 550 V					
Min. DC voltage / start voltage	100 V / 125 V					
Max. operating input current per MPPT	10 A					
Max. short circuit current per MPPT	18 A					
Number of MPPT tracker / string per MPPT tracker	3 / 1					
<b>Output (AC)</b>						
AC nominal power	5200 W	6000 W	6660 W	7000 W	6660 W	7680 W
Max. AC apparent power	5200 VA	6000 VA	6660 VA	7000 VA	6660 VA	7680 VA
Nominal voltage / adjustable	208 V / ●	240 V / ●	208 V / ●	240 V / ●	208 V / ●	240 V / ●
AC voltage range	183 - 229 V	211 - 264 V	183 - 229 V	211 - 264 V	183 - 229 V	211 - 264 V
AC grid frequency	60 Hz / 50 Hz					
Max. output current	25.0 A	25.0 A	32.0 A	29.2 A	32.0 A	32.0 A
Power factor (cos φ)	1					
Output phases / line connections	1 / 2					
Harmonics	< 4 %					
<b>Efficiency</b>						
Max. efficiency	97.3 %	97.7 %	97.3 %	97.9 %	97.3 %	97.5 %
CEC efficiency	96.7 %	96.9 %	96.4 %	96.8 %	96.4 %	96.8 %
<b>Protection devices</b>						
DC disconnect device / DC reverse polarity protection	● / ●					
Ground fault monitoring / Grid monitoring	●					
AC short circuit protection	●					
All-pole sensitive residual current monitoring unit (RCMU)	●					
Arc fault circuit interrupter (AFCI)	●					
Protection class / overvoltage category	I / IV					
<b>General data</b>						
Dimensions (W / H / D) in mm (in)	535 x 730 x 198 (21.1 x 28.5 x 7.8)					
Packaging Dimensions (W / H / D) in mm (in)	600 x 800 x 300 (23.6 x 31.5 x 11.8)					
Weight / packaging weight	26 kg (57 lb) / 30 kg (66 lb)					
Temperature range: operating / non-operating	-25 °C ... +60 °C / -40 °C ... +60 °C					
Environmental protection rating	NEMA 3R					
Noise emission (typical)	39 dB(A)		45 dB(A)			
Internal power consumption at night	< 5 W					
Topology / Cooling concept	Transformerless / Convection			Transformerless / Fan		
<b>Features</b>						
Ethernet ports	2					
Secure Power Supply	●*					
Display (2 x 16 characters)	●					
2.4 GHz WLAN / External WLAN antenna	●/○					
Cellular (4G / 3G) / Revenue Grade Meter	○/○**					
Warranty: 10 / 15 / 20 years	●/○/○					
Certificates and approvals	UL 1741, UL 1741 SA incl. CA Rule 21 RSD, UL 1998, UL 1699B Ed. 1, IEEE1547, FCC Part 15 (Class A & B), CAN/CSA V22.2 107.1-1, HECO Rule 14H, PV Rapid Shutdown System Equipment					
● Standard features ○ Optional features – Not available						
NOTE: US inverters ship with gray lids. * Not compatible with the SunSpec Rapid Shutdown functionality. ** Standard in SBX.X-1TP-US-41						
Type designation	SB6.0-1SP-US-41 / SB6.0-1TP-US-41	SB7.0-1SP-US-41 / SB7.0-1TP-US-41	SB7.7-1SP-US-41 / SB7.7-1TP-US-41			

## POWER+ SOLUTION

The SMA Power+ Solution combines legendary SMA inverter performance and intelligent DC module-level electronics in one cost-effective, comprehensive package. This means that you can achieve maximum solar power production for your customers while also realizing significant installation savings.

**NEW!** This rapid shutdown solution fulfills UL 1741, NEC 2014, and NEC 2017 requirements and is compatible with the power line-based SunSpec Rapid Shutdown communication signal over DC wires, making it the most simple and cost-effective rapid shutdown solution on the market.

Visit [www.SMA-America.com](http://www.SMA-America.com) for more information.



### SIMPLE, FLEXIBLE DESIGN

Speed the completion of customer proposals and maximize the efficiency of your design team with the Sunny Boy-US series, which provides a new level of flexibility in system design by offering:

- » Hundreds of stringing configurations and multiple independent MPPTs
- » SMA's proprietary OptiTrac™ Global Peak shade mitigation technology
- » Diverse application options including on- and off-grid compatibility



### VALUE-DRIVEN SALES ENABLEMENT

SMA wants to enable your sales team by arming them with an abundance of feature/benefit support. Show your customers the value of the Sunny Boy-US series by utilizing:

- » Secure Power Supply, now with 2,000 W of opportunity power in the event of a grid outage, as an increased value-add or upsell opportunity
- » SMA's 35 year history and status as the #1 global inverter manufacturer instills homeowners with peace of mind and the long-term security they demand from a PV investment
- » An economical solution for shade mitigation and the challenges of complex roofs



### IMPROVED STOCKING AND ORDERING

Ensure that your back office business operations run smoothly and succinctly while mitigating potential errors. The Sunny Boy-US series can help achieve cost savings in these areas by providing:

- » An integrated DC disconnect that simplifies equipment stocking and allows for a single inverter part number
- » All communications integrated into the inverter, eliminating the need to order additional equipment



### STREAMLINED INSTALLATION AND COMMISSIONING

Expedite your operations in the field by taking advantage of the new Sunny Boy's installer-friendly feature set including:

- » Direct access via smartphone and utilization of SMA's Installation Assistant, which minimizes time/labor spent in the field and speeds the path to commissioning
- » Simple commissioning and monitoring setup in a single online portal
- » New! Advanced communication interface with fewer components allows for 50% faster commissioning

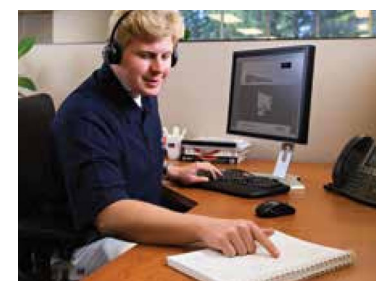

### SUPERIOR SERVICE

SMA understands the factors that contribute to lifetime PV ownership cost, that's why the Sunny Boy-US series was designed for maximum reliability and backstopped by an unmatched service offering. Benefit from:

- » SMA Smart Connected, a proactive service solution integrated into Sunny Portal that automatically detects errors and initiates the repair and replacement process
- » The #1 service team in the PV industry, as recognized by IMS research, with experience servicing an installed base of more than 55 GW



# SOLARMOUNT



**SOLARMOUNT** defined the standard in solar racking. Features are designed to get installers off the roof faster. Our grounding & bonding process eliminates copper wire and grounding straps to reduce costs. Systems can be configured with standard or light rail to meet your design requirements at the lowest cost possible. The superior aesthetics package provides a streamlined clean edge for enhanced curb appeal, with no special brackets required for installation.

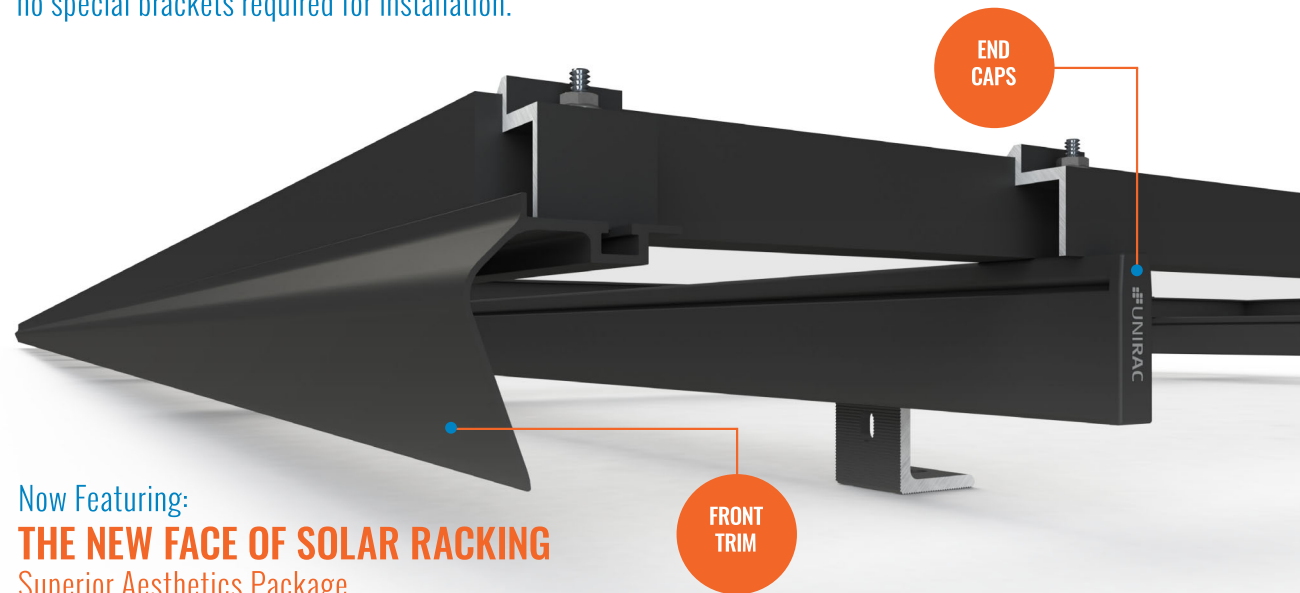

Now Featuring:  
**THE NEW FACE OF SOLAR RACKING**  
Superior Aesthetics Package



**LOSE ALL OF THE COPPER & LUGS**  
System grounding through Enphase microinverters and trunk cables



**SMALL IS THE NEXT NEW BIG THING**  
Light Rail is Fully Compatible with all SM Components

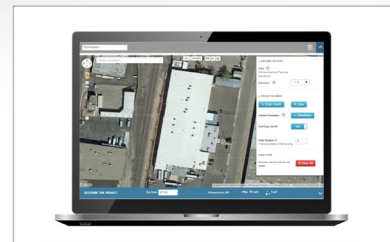

**ENHANCED DESIGN & LAYOUT TOOLS**  
Featuring Google Map Capabilities within U-Builder

## FAST INSTALLATION. SUPERIOR AESTHETICS

OPTIMIZED COMPONENTS • VERSATILITY • DESIGN TOOLS • QUALITY PROVIDER

# SOLARMOUNT



## OPTIMIZED COMPONENTS

### INTEGRATED BONDING & PRE-ASSEMBLED PARTS

Components are pre-assembled and optimized to reduce installation steps and save labor time. Our new grounding & bonding process eliminates copper wire and grounding straps or bonding jumpers to reduce costs. Utilize the microinverter mount with a wire management clip for an easier installation.

## VERSATILITY

### ONE PRODUCT - MANY APPLICATIONS

Quickly set modules flush to the roof or at a desired tilt angle. Change module orientation to portrait or landscape while securing a large variety of framed modules on flat, low slope or steep pitched roofs. Available in mill, clear and dark anodized finishes to outperform your projects financial and aesthetic aspirations.

## AUTOMATED DESIGN TOOL

### DESIGN PLATFORM AT YOUR SERVICE

Creating a bill of materials is just a few clicks away with U-Builder, a powerful online tool that streamlines the process of designing a code compliant solar mounting system. Save time by creating a user profile, and recall preferences and projects automatically when you log in. You will enjoy the ability to share projects with customers; there's no need to print results and send to a distributor, just click and share.

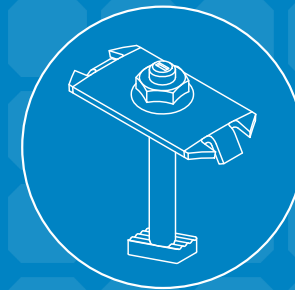

INTEGRATED BONDING  
MIDCLAMP

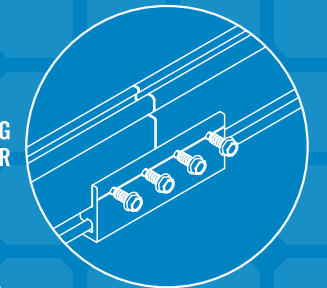

INTEGRATED BONDING  
SPLICE BAR



INTEGRATED BONDING  
L-FOOT w/ T-BOLT

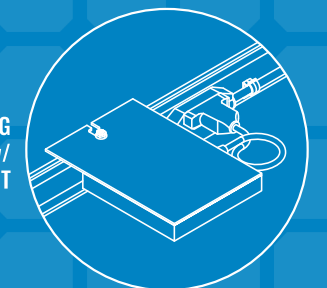

INTEGRATED BONDING  
MICROINVERTER MOUNT w/  
WIRE MANAGEMENT



## UNIRAC CUSTOMER SERVICE MEANS THE HIGHEST LEVEL OF PRODUCT SUPPORT



UNMATCHED  
EXPERIENCE



CERTIFIED  
QUALITY



ENGINEERING  
EXCELLENCE



BANKABLE  
WARRANTY



DESIGN  
TOOLS

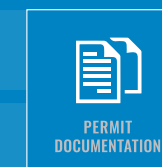

PERMIT  
DOCUMENTATION

### TECHNICAL SUPPORT

Unirac's technical support team is dedicated to answering questions & addressing issues in real time. An online library of documents including engineering reports, stamped letters and technical data sheets greatly simplifies your permitting and project planning process.

### CERTIFIED QUALITY PROVIDER

Unirac is the only PV mounting vendor with ISO certifications for 9001:2015, 14001:2015 and OHSAS 18001:2007, which means we deliver the highest standards for fit, form, and function. These certifications demonstrate our excellence and commitment to first class business practices.

### BANKABLE WARRANTY

Don't leave your project to chance. Unirac has the financial strength to back our products and reduce your risk. Have peace of mind knowing you are receiving products of exceptional quality. SOLARMOUNT is covered by a twenty five (25) year limited product warranty and a five (5) year limited finish warranty.

PROTECT YOUR REPUTATION WITH QUALITY RACKING SOLUTIONS BACKED BY ENGINEERING EXCELLENCE AND A SUPERIOR SUPPLY CHAIN

PUB2017FEB28 - PRINTED

# FLASH LOC



**FLASHLOC** is the ultimate attachment for composition shingle and rolled comp roofs. The all-in-one mount installs fast — no kneeling on hot roofs to install flashing, no prying or cutting shingles, no pulling nails. Simply drive the lag bolt and inject sealant into the base. **FLASHLOC's** patented TRIPLE SEAL technology preserves the roof and protects the penetration with a permanent pressure seal. Kitted with lag bolts, sealant, and hardware for maximum convenience. Don't just divert water, **LOC it out!**



JUNE2021\_FLASHLOCCOMP\_V2



### PROTECT THE ROOF

Install a high-strength waterproof attachment without lifting, prying or damaging shingles.

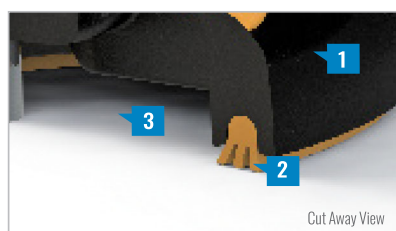

### LOC OUT WATER

With an outer shield **1**, contour-conforming gasket **2** and pressurized sealant chamber **3** the Triple Seal technology delivers a 100% waterproof connection.



### HIGH-SPEED INSTALL

Simply drive lag bolt and inject sealant into the port **4** to create a permanent pressure seal.

# FLASH LOC

## INSTALLATION GUIDE



### PRE-INSTALL

Snap chalk lines for attachment rows. On shingle roofs, snap lines 1-3/4" below upslope edge of shingle course. Locate rafters and mark attachment locations.

At each location, drill a 7/32" pilot hole. Clean roof surface of dirt, debris, snow, and ice. Next, BACKFILL ALL PILOT HOLES WITH SEALANT.

**NOTE:** Space mounts per racking system install specifications.



### STEP 1: SECURE

Place **FLASHLOC** over pilot hole with lag on down-slope side. Align indicator marks on sides of mount with chalk line. Pass included lag bolt and sealing washer through **FLASHLOC** into pilot hole. Drive lag bolt until mount is held firmly in place.

**NOTE:** The EPDM in the sealing washer will expand beyond the edge of the metal washer when proper torque is applied.



### STEP 2: SEAL

Insert tip of UNIRAC provided sealant into port. Inject until sealant exits both vents. Follow sealant manufacturer's instructions. Follow sealant manufacturer's cold weather application guidelines, if applicable.

Continue array installation, attaching rails to mounts with provided T-bolts.



**NOTE:** When **FLASHLOC** is installed over gap between shingle tabs or vertical joints, fill gap/joint with sealant between mount and upslope edge of shingle course.

**USE ONLY UNIRAC APPROVED SEALANTS:** Chemlink Duralink 50, Chemlink M-1, Geocel 4500, or Geocel S-4

**FASTER INSTALLATION. 25-YEAR WARRANTY.**

FOR QUESTIONS OR CUSTOMER SERVICE VISIT UNIRAC.COM OR CALL (505) 248-2702

**FASTER INSTALLATION. 25-YEAR WARRANTY.**

FOR QUESTIONS OR CUSTOMER SERVICE VISIT UNIRAC.COM OR CALL (505) 248-2702