

PROJECT DESCRIPTION:

22 X MISSION SOLAR: MSE345SX5T 345W MODULES
 GROUND MOUNTED SOLAR PHOTOVOLTAIC MODULES
 DC SYSTEM SIZE: 7.590KW DC
 AC SYSTEM SIZE: 7.600KW AC

EQUIPMENT SUMMARY

22 MISSION SOLAR: MSE345SX5T 345W MODULES
 22 GENERAC SNAPRS801
 03 GENERAC PV LINK S2502 POWER OPTIMIZERS
 01 GENERAC PWRCELL: X7602 7600W INVERTER
 01 GENERAC PWRCELL: 9kW (18kWh) BATTERY

GROUND ARRAY AREA:- 436.26 SQ FT

AUTHORITIES HAVING JURISDICTION

BUILDING: HARNETT COUNTY
 ZONING: HARNETT COUNTY
 UTILITY: DUKE ENERGY

APPLICABLE CODES & STANDARDS

NCBC 2018
 NEC 2017

DESIGN SPECIFICATIONS

OCCUPANCY: II
 CONSTRUCTION: SINGLE-FAMILY
 ZONING: RESIDENTIAL
 GROUND SNOW LOAD: 10 PSF
 WIND EXPOSURE: B
 WIND SPEED: 115 MPH

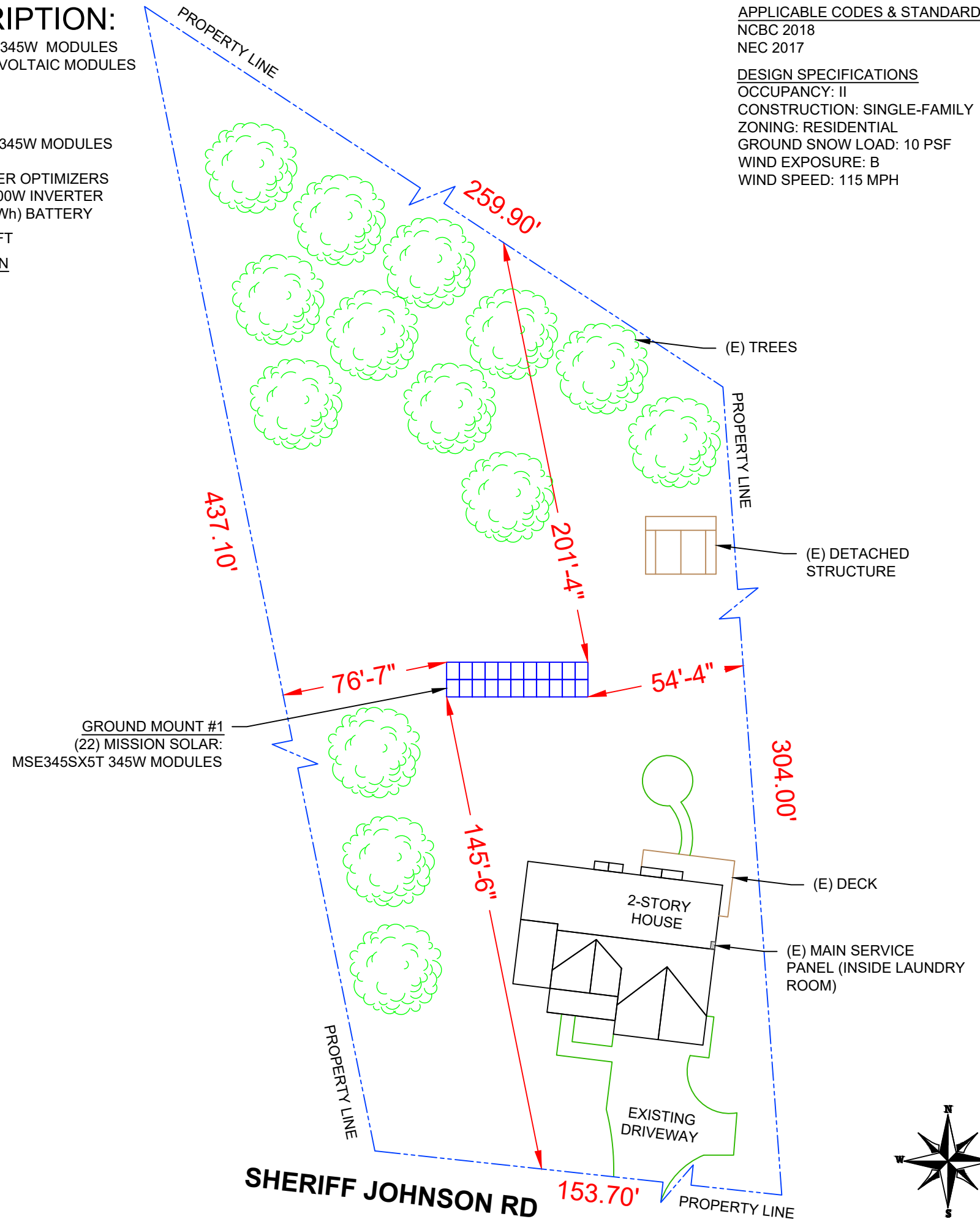

2 HOUSE PHOTO

PV-1 SCALE: NTS

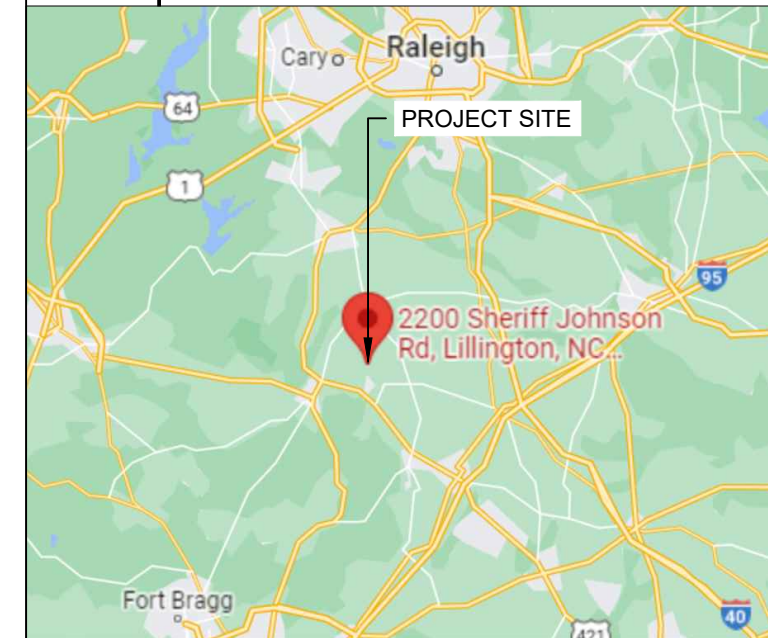

3 VICINITY MAP

PV-1 SCALE: NTS

SHEET INDEX

- PV-1 PLOT PLAN, HOUSE PHOTO & VICINITY MAP
- PV-2 ARRAY PLAN
- PV-2A STRING LAYOUT
- PV-3 ATTACHMENT DETAIL
- PV-3A RACKING DETAIL
- PV-4 ELECTRICAL LINE DIAGRAM
- PV-5 WIRING CALCULATIONS
- PV-6 LABELS
- PV-7 PLACARD
- PV-8 POWER OPTIMIZER CHART
- PV-9+ EQUIPMENT SPECIFICATIONS

1 PLOT PLAN

PV-1 SCALE: 1/32" = 1'-0"



REVISIONS		
DESCRIPTION	DATE	REV
INITIAL	07/01/2022	
MSP LOCATION CHANGE	07/14/2022	A
TRENCH ROUTE CHANGE	08/24/2022	B

SIGNATURE WITH SEAL

 DATE: 07/14/2022

PROJECT NAME & ADDRESS
DEVON DODD RESIDENCE
 2200 SHERIFF JOHNSON RD
 LILLINGTON, NC 27546

DC SIZE: 7.590 KW
 AC SIZE: 7.600 KW

SHEET NAME
PLOT PLAN & VICINITY MAP

SHEET SIZE
**ANSI B
 11" X 17"**

SHEET NUMBER
PV-1

MODULE TYPE, DIMENSIONS & WEIGHT

NUMBER OF MODULES = 22 MODULES
 MODULE TYPE = MISSION SOLAR: MSE345SX5T 345W MODULES
 MODULE WEIGHT = 44.80 LBS / 20.32 KG.
 MODULE DIMENSIONS = 68.80"x 41.50" = 19.83 SF

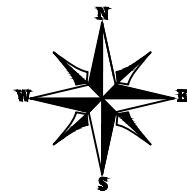

GROUND MOUNT #1
 TILT - 35°
 AZIM. - 180°

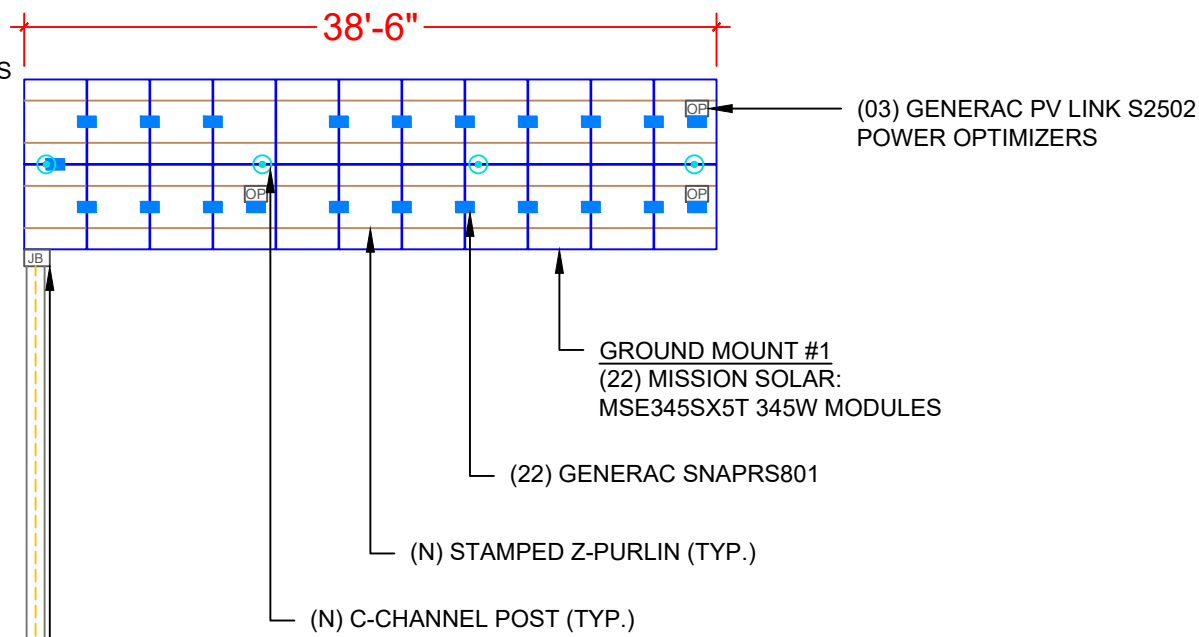
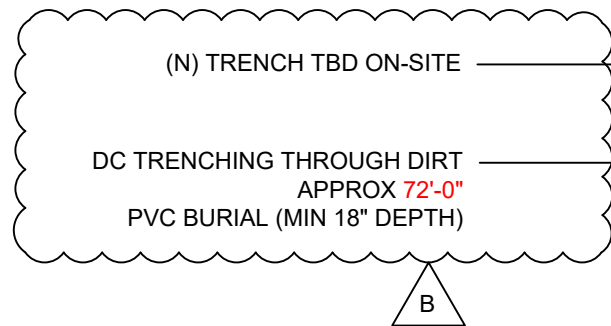

LEGEND

- BAT - BATTERY
- INV - INVERTER
- ACD - AC DISCONNECT
- MSP - MAIN SERVICE PANEL
- ATS - AUTOMATIC TRANSFER SWITCH
- SD - SOLADECK
- OP - PV LINK -S2502
- - SNAPRS801

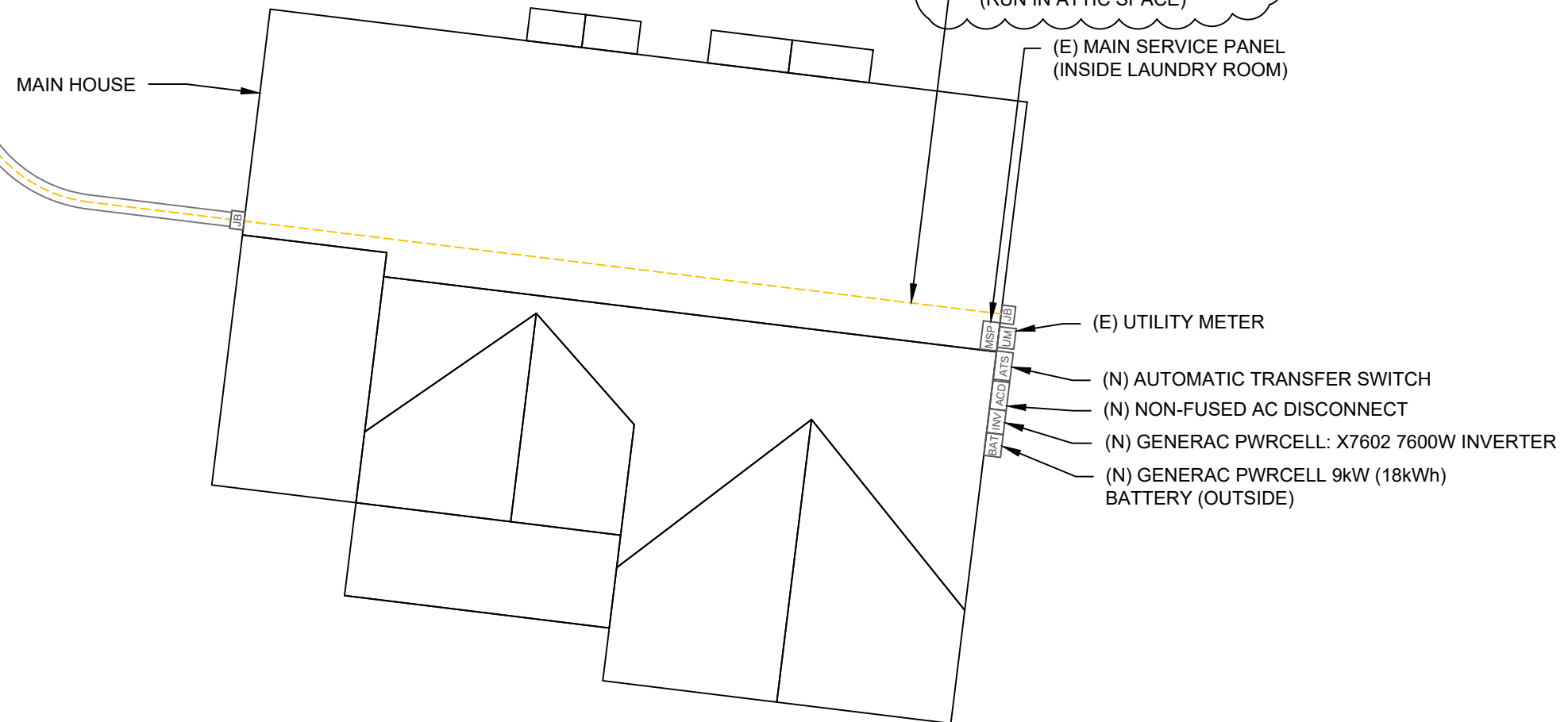
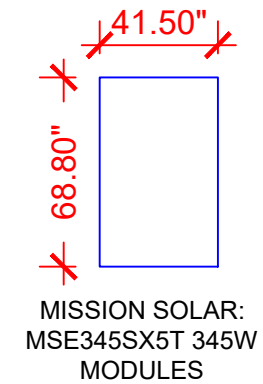

REVISIONS		
DESCRIPTION	DATE	REV
INITIAL	07/01/2022	
MSP LOCATION CHANGE	07/14/2022	A
TRENCH ROUTE CHANGE	08/24/2022	B

SIGNATURE WITH SEAL

DATE: 07/14/2022

PROJECT NAME & ADDRESS

DEVON DODD RESIDENCE
 2200 SHERIFF JOHNSON RD
 LILLINGTON, NC 27546

DC SIZE: 7.590 KW
 AC SIZE: 7.600 KW

SHEET NAME
ARRAY PLAN

SHEET SIZE
**ANSI B
 11" X 17"**

SHEET NUMBER
PV-2

STRING LEGENDS	
	STRING #1
	STRING #2
	STRING #3

BILL OF MATERIALS		
EQUIPMENT	QTY	DESCRIPTION
SOLAR PV MODULE	22	MISSION SOLAR: MSE345SX5T 345W MODULES
SNAPRS	22	GENERAC SNAPRS801
OPTIMIZER	3	GENERAC PV LINK S2502 POWER OPTIMIZERS
INVERTER	1	GENERAC PWRCELL: X7602 7600W INVERTER
BATTERY	1	GENERAC PWRCELL: 9kW (18kWh) BATTERY
JUNCTION BOXES	3	6"X6"X4" UL LISTED, STEEL WATER TIGHT NEMA TYPE 3R, UL LISTED
AC DISCONNECT	1	60A NON-FUSED AC DISCONNECT, 240V NEMA 3R, UL LISTED

B



REVISIONS		
DESCRIPTION	DATE	REV
INITIAL	07/01/2022	
MSP LOCATION CHANGE	07/14/2022	A
TRENCH ROUTE CHANGE	08/24/2022	B

SIGNATURE WITH SEAL

DATE: 07/14/2022

PROJECT NAME & ADDRESS

DEVON DODD
RESIDENCE
2200 SHERIFF JOHNSON RD
LILLINGTON, NC 27546

DC SIZE: 7.590 KW
AC SIZE: 7.600 KW

SHEET NAME
STRING LAYOUT

SHEET SIZE
ANSI B
11" X 17"

SHEET NUMBER
PV-2A

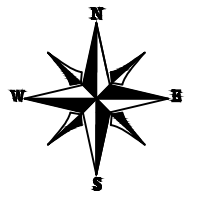
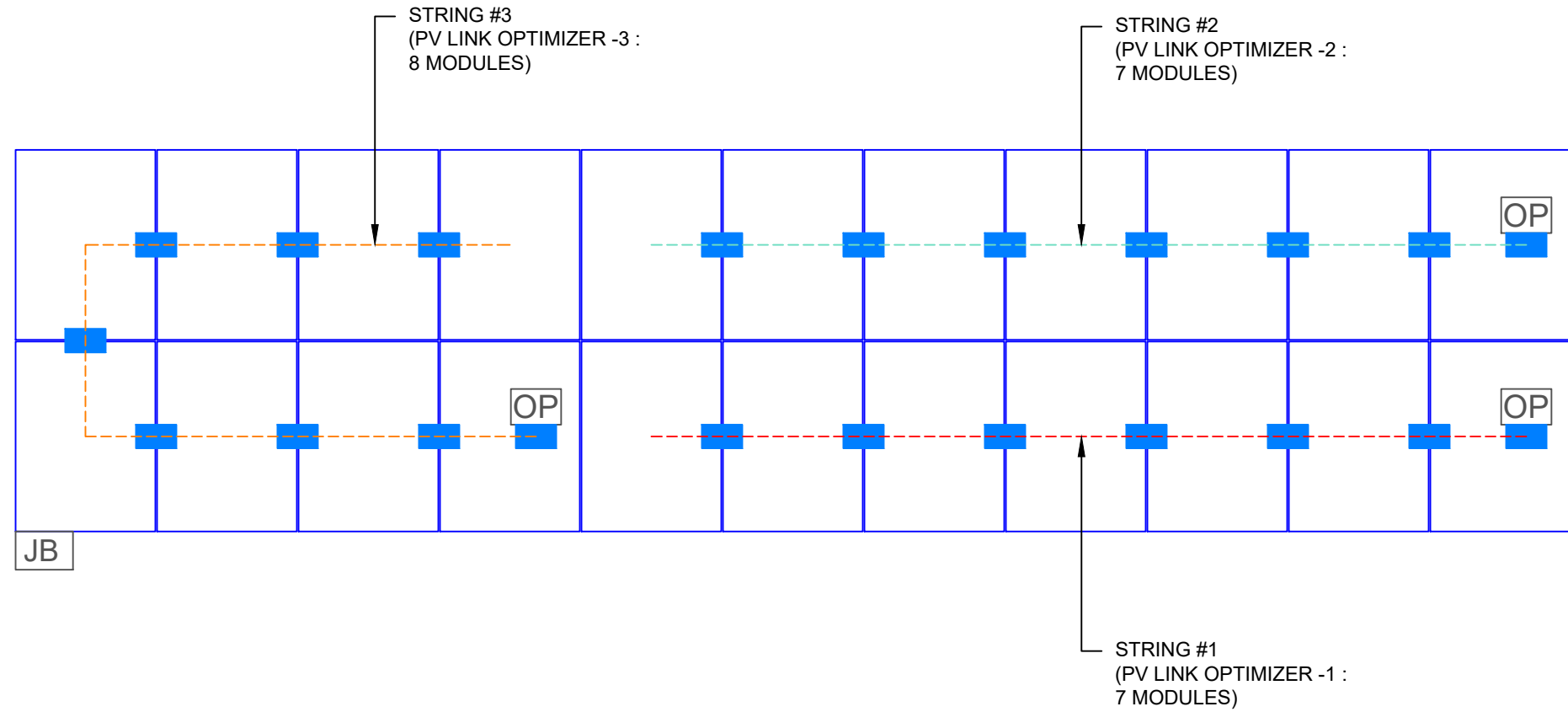

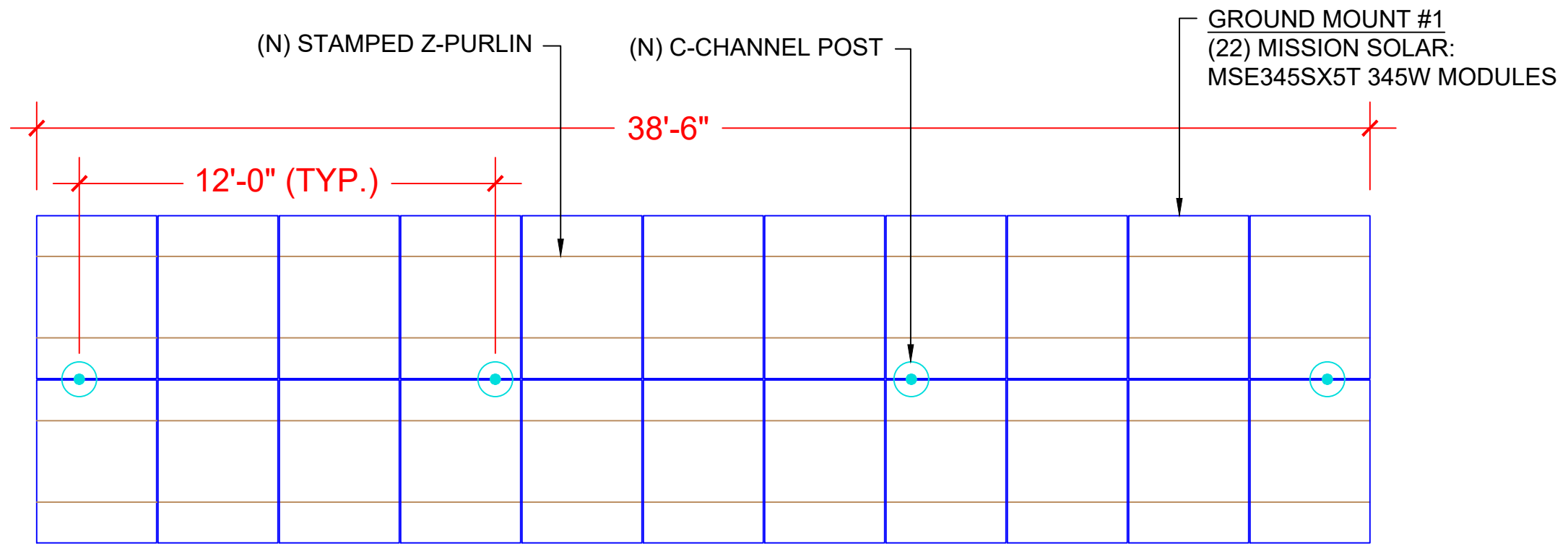

1 RACKING DETAIL (Top View)

PV-3

SCALE: NTS

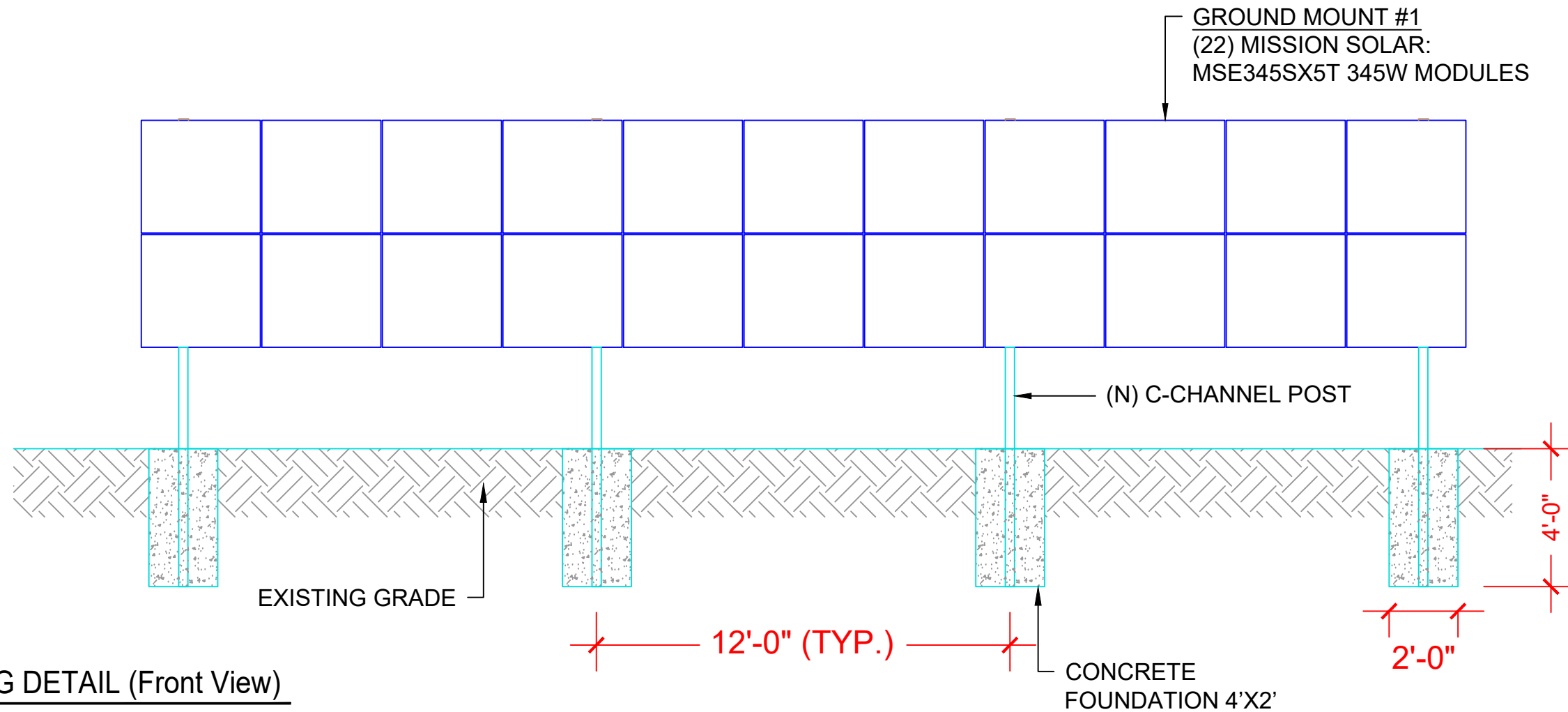

PV-3

SCALE: NTS



REVISIONS

DESCRIPTION	DATE	REV
INITIAL	07/01/2022	
MSP LOCATION CHANGE	07/14/2022	A
TRENCH ROUTE CHANGE	08/24/2022	B

SIGNATURE WITH SEAL

DATE: 07/14/2022

PROJECT NAME & ADDRESS

DEVON DODD
RESIDENCE
2200 SHERIFF JOHNSON RD
LILLINGTON, NC 27546

DC SIZE: 7.590 KW
AC SIZE: 7.600 KW

SHEET NAME
ATTACHMENT
DETAIL

SHEET SIZE
ANSI B
11" X 17"

SHEET NUMBER
PV-3

DC SYSTEM SIZE: 7.590KW DC
 AC SYSTEM SIZE: 7.600KW AC

(22) MISSION SOLAR: MSE345SX5T 345W MODULES
 WITH (22) GENERAC SNAPRS801
 (2) STRINGS OF 7 MODULES AND
 (1) STRING OF 8 MODULES CONNECTED IN SERIES

RACKING NOTE:-
 1. BOND EVERY RAIL WITH #6 BARE COPPER

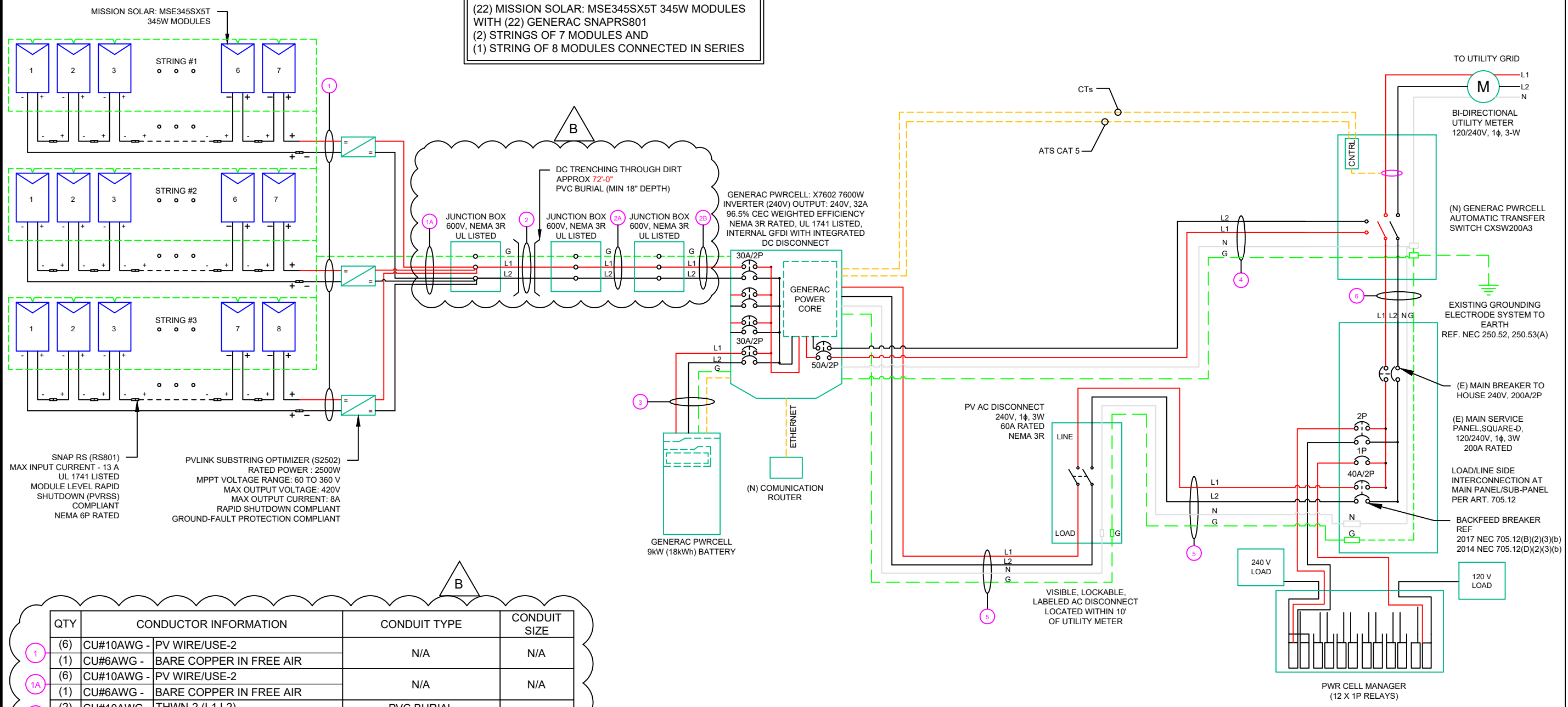

QTY	CONDUCTOR INFORMATION	CONDUIT TYPE	CONDUIT SIZE
1	(6) CU#10AWG - PV WIRE/USE-2	N/A	N/A
1A	(1) CU#6AWG - BARE COPPER IN FREE AIR	N/A	N/A
2	(6) CU#10AWG - PV WIRE/USE-2	N/A	N/A
1A	(1) CU#6AWG - BARE COPPER IN FREE AIR	N/A	N/A
2	(2) CU#10AWG - THWN-2 (L1,L2)	PVC BURIAL (MIN 18" DEPTH)	3/4"
1A	(1) CU#10AWG - THWN-2 GND	PVC, LFNC OR LFMC IN ATTIC	3/4"
2A	(2) CU#10AWG - THWN-2 (L1,L2)	PVC, LFNC OR LFMC	3/4"
1A	(1) CU#10AWG - THWN-2 GND	PVC, LFNC OR LFMC	3/4"
2B	(2) CU#10AWG - THWN-2 (L1,L2)	PVC, LFNC OR LFMC	3/4"
1A	(1) CU#10AWG - THWN-2 GND	PVC, LFNC OR LFMC	3/4"
3	(2) CU#10AWG - THWN-2 (L1,L2)	EMT OR LFMC	3/4"
1A	(1) CU#10AWG - THWN-2 GND	EMT OR LFMC	3/4"
4	(1) CU#6AWG - THWN-2 NEUTRAL	EMT OR LFMC	3/4"
1A	(1) CU#6AWG - THWN-2 GND	EMT OR LFMC	3/4"
5	(2) CU#6AWG - THWN-2 (L1,L2)	EMT OR LFMC	3/4"
1A	(1) CU#6AWG - THWN-2 NEUTRAL	EMT OR LFMC	3/4"
1A	(1) CU#6AWG - THWN-2 GND	EMT OR LFMC	3/4"
6	(2) CU#2/0AWG - THWN-2 (L1,L2)	EMT OR LFMC	2"
1A	(1) CU#1/0AWG - THWN-2 NEUTRAL	EMT OR LFMC	2"
1A	(1) CU#6AWG - THWN-2 GND	EMT OR LFMC	2"

SERVICE INFO

UTILITY PROVIDER: **DUKE ENERGY**

MAIN SERVICE VOLTAGE: 240V

MAIN PANEL BRAND: SQUARE D

MAIN SERVICE PANEL: 200A

MAIN CIRCUIT BREAKER RATING: 200A

MAIN SERVICE LOCATION: SOUTH-EAST

SERVICE FEED SOURCE: UNDERGROUND

REVISIONS

DESCRIPTION	DATE	REV
INITIAL	07/01/2022	
MSP LOCATION CHANGE	07/14/2022	A
TRENCH ROUTE CHANGE	08/24/2022	B

SIGNATURE WITH SEAL

DATE: 07/14/2022

PROJECT NAME & ADDRESS

DEVON DODD RESIDENCE

2200 SHERIFF JOHNSON RD
 LILLINGTON, NC 27546

DC SIZE: 7.590 KW
 AC SIZE: 7.600 KW

SHEET NAME
ELECTRICAL LINE DIAGRAM

SHEET SIZE
**ANSI B
 11" X 17"**

SHEET NUMBER
PV-4

SOLAR MODULE SPECIFICATIONS	
MANUFACTURER / MODEL #	MISSION SOLAR: MSE345SX5T 345W MONO MODULES
VMP	33.37V
IMP	10.34A
VOC	41.00V
ISC	10.92A
TEMP. COEFF. VOC	-0.262%/°C
MODULE DIMENSION	68.80"L x 41.50"W x 1.60"D (In Inch)

AMBIENT TEMPERATURE SPECS	
RECORD LOW TEMP	-10°
AMBIENT TEMP (HIGH TEMP 2%)	35°
MODULE TEMPERATURE COEFFICIENT OF Voc	-0.262%/°C

INVERTER SPECIFICATIONS	
MANUFACTURER / MODEL #	GENERAC PWRCELL: X7602 7600W INVERTER
NOMINAL AC POWER	7.600 KW
NOMINAL OUTPUT VOLTAGE	240 VAC
NOMINAL OUTPUT CURRENT	32 A

PERCENT OF	VALUES	NUMBER OF CURRENT CARRYING CONDUCTORS IN EMT
0.80		4-6
0.70		7-9
0.50		10-20

POWER OPTIMIZER (GENERAC PV LINK S2502 POWER OPTIMIZERS)	
RATED POWER	2500W
MAXIMUM INPUT VOLTAGE	420Voc
MPPT VOLTAGE RANGE	60-360Vmp
NOMINAL OUTPUT	380Vdc
MAXIMUM OUTPUT	420A dc
MAXIMUM OUTPUT CURRENT	8A
MAXIMUM SHORT CIRCUIT CURRENT	18A



DC FEEDER CALCULATIONS

CIRCUIT ORIGIN	CIRCUIT DESTINATION	VOLTAGE (V)	FULL LOAD AMPS "FLA" (A)	FLA*1.25 (A)	OCPD SIZE (A)	GROUND SIZE	CONDUCTOR SIZE	75°C AMPACITY (A)	AMPACITY CHECK #1	AMBIENT TEMP. (°C)	TOTAL CC CONDUCTORS IN RACEWAY	90°C AMPACITY (A)	DERATION FACTOR FOR AMBIENT TEMPERATURE NEC 310.15(B)(2)(a)	DERATION FACTOR FOR CONDUCTORS PER RACEWAY NEC 310.15(B)(3)(a)	90°C AMPACITY DERATED (A)	AMPACITY CHECK #2	FEEDER LENGTH (FEET)	CONDUCTOR RESISTANCE (OHM/KFT)	VOLTAGE DROP AT FLA (%)	CONDUIT SIZE	CONDUIT FILL (%)
STRING 1	JUNCTION BOX #1	380	8.00	10.00	20	BARE COPPER #6 AWG	CU #10 AWG	35	PASS	35	2	40	0.96	1	38.4	PASS	4	1.24	0.021	N/A	#N/A
STRING 2	JUNCTION BOX #1	380	8.00	10.00	20	BARE COPPER #6 AWG	CU #10 AWG	35	PASS	35	2	40	0.96	1	38.4	PASS	4	1.24	0.021	N/A	#N/A
STRING 3	JUNCTION BOX #1	380	8.00	10.00	20	BARE COPPER #6 AWG	CU #10 AWG	35	PASS	35	2	40	0.96	1	38.4	PASS	4	1.24	0.021	N/A	#N/A
JUNCTION BOX #1	JUNCTION BOX #2	380	24.00	30.00	30	CU #10 AWG	CU #10 AWG	35	PASS	35	2	40	0.96	1	38.4	PASS	72	1.24	1.128	3/4" PVC	12.46063
JUNCTION BOX #2	JUNCTION BOX #3	380	24.00	30.00	30	CU #10 AWG	CU #10 AWG	35	PASS	35	2	40	0.96	1	38.4	PASS	50	1.24	0.783	3/4" PVC	12.46063
JUNCTION BOX #3	INVERTER	380	24.00	30.00	30	CU #10 AWG	CU #10 AWG	35	PASS	35	2	40	0.96	1	38.4	PASS	4	1.24	0.063	3/4" EMT	11.87617

String 1 Voltage Drop	1.994
String 2 Voltage Drop	1.994
String 3 Voltage Drop	1.994

AC FEEDER CALCULATIONS																						
CIRCUIT ORIGIN	CIRCUIT DESTINATION	VOLTAGE (V)	FULL LOAD AMPS "FLA" (A)	FLA*1.25 (A)	OCPD SIZE (A)	NEUTRAL SIZE	GROUND SIZE	CONDUCTOR SIZE	75°C AMPACITY (A)	AMPACITY CHECK #1	AMBIENT TEMP. (°C)	TOTAL CC CONDUCTORS IN RACEWAY	90°C AMPACITY (A)	DERATION FACTOR FOR AMBIENT TEMPERATURE NEC 310.15(B)(2)(a)	DERATION FACTOR FOR CONDUCTORS PER RACEWAY NEC 310.15(B)(3)(a)	90°C AMPACITY DERATED (A)	AMPACITY CHECK #2	FEEDER LENGTH (FEET)	CONDUCTOR RESISTANCE (OHM/KFT)	VOLTAGE DROP AT FLA (%)	CONDUIT SIZE	CONDUIT FILL (%)
INVERTER 1	AC DISCONNECT	240	32	40	40	CU #6 AWG	CU #6 AWG	CU #6 AWG	65	PASS	35	2	75	0.96	1	72	PASS	5	0.491	0.065	3/4" EMT	38.0488
AC DISCONNECT	POI	240	32	40	40	CU #6 AWG	CU #6 AWG	CU #6 AWG	65	PASS	35	2	75	0.96	1	72	PASS	5	0.491	0.065	3/4" EMT	38.0488

CUMULATIVE VOLTAGE DROP	0.21
-------------------------	------

ELECTRICAL NOTES

- ALL EQUIPMENT TO BE LISTED BY UL OR OTHER NRTL, AND LABELED FOR ITS APPLICATION.
- ALL CONDUCTORS SHALL BE COPPER, RATED FOR 600 V AND 90 DEGREE C WET ENVIRONMENT.
- WIRING, CONDUIT, AND RACEWAYS MOUNTED ON GROUND SHALL BE ROUTED DIRECTLY TO, AND LOCATED AS CLOSE AS POSSIBLE TO THE NEAREST RIDGE, HIP, OR VALLEY.
- WORKING CLEARANCES AROUND ALL NEW AND EXISTING ELECTRICAL EQUIPMENT SHALL COMPLY WITH NEC 110.26.
- DRAWINGS INDICATE THE GENERAL ARRANGEMENT OF SYSTEMS. CONTRACTOR SHALL FURNISH ALL NECESSARY OUTLETS, SUPPORTS, FITTINGS AND ACCESSORIES TO FULFILL APPLICABLE CODES AND STANDARDS.
- WHERE SIZES OF JUNCTION BOX, RACEWAYS, AND CONDUITS ARE NOT SPECIFIED, THE CONTRACTOR SHALL SIZE THEM ACCORDINGLY.
- ALL WIRE TERMINATIONS SHALL BE APPROPRIATELY LABELED AND READILY VISIBLE.
- MODULE GROUNDING CLIPS TO BE INSTALLED BETWEEN MODULE FRAME AND MODULE SUPPORT RAIL, PER THE GROUNDING CLIP MANUFACTURER'S INSTRUCTION.
- MODULE SUPPORT RAIL TO BE BONDED TO CONTINUOUS COPPER G.E.C. VIA WEEB LUG OR ILSKO GBL-4DBT LAY-IN LUG.
- TEMPERATURE RATINGS OF ALL CONDUCTORS, TERMINATIONS, BREAKERS, OR OTHER DEVICES ASSOCIATED WITH THE SOLAR PV SYSTEM SHALL BE RATED FOR AT LEAST 75 DEGREE C.



REVISIONS		
DESCRIPTION	DATE	REV
INITIAL	07/01/2022	
MSP LOCATION CHANGE	07/14/2022	A
TRENCH ROUTE CHANGE	08/24/2022	B

SIGNATURE WITH SEAL

DATE: 07/14/2022

PROJECT NAME & ADDRESS

DEVON DODD RESIDENCE

2200 SHERIFF JOHNSON RD
LILLINGTON, NC 27546

DC SIZE: 7.590 KW
AC SIZE: 7.600 KW

SHEET NAME
WIRING CALCULATIONS

SHEET SIZE
ANSI B 11" X 17"

SHEET NUMBER
PV-5

**CAUTION:
AUTHORIZED SOLAR
PERSONNEL ONLY!**

LABEL-1:
LABEL LOCATION:
AC DISCONNECT

**WARNING: PHOTOVOLTAIC
POWER SOURCE**

EVERY 10' ON CONDUIT & ENCLOSURES

LABEL- 2:
LABEL LOCATION:
EMT/CONDUIT RACEWAY
SOLADECK / JUNCTION BOX
CODE REF: NEC 690.31 (D)(2)

WARNING
ELECTRICAL SHOCK HAZARD
TERMINALS ON THE LINE AND LOAD SIDES MAY
BE ENERGIZED IN THE OPEN POSITION

LABEL- 3:
LABEL LOCATION:
AC DISCONNECT
INVERTER
MAIN SERVICE PANEL
SUBPANEL
MAIN SERVICE DISCONNECT
CODE REF: NEC 690.13(B)

**WARNING DUAL POWER SOURCE
SECOND SOURCE IS PHOTOVOLTAIC SYSTEM**

LABEL- 4:
LABEL LOCATION:
PRODUCTION METER
UTILITY METER
MAIN SERVICE PANEL
SUBPANEL
CODE REF: NEC 705.12(C) & NEC 690.59

WARNING
**TURN OFF PHOTOVOLTAIC AC
DISCONNECT PRIOR TO
WORKING INSIDE PANEL**

LABEL- 5:
LABEL LOCATION:
MAIN SERVICE PANEL
SUBPANEL
MAIN SERVICE DISCONNECT
CODE REF: NEC 110.27(C) & OSHA 1910.145 (f) (7)

CAUTION
**PHOTOVOLTAIC SYSTEM CIRCUIT IS
BACKFEED**

LABEL- 6:
LABEL LOCATION:
MAIN SERVICE PANEL (ONLY IF SOLAR IS BACK-FED)
SUBPANEL (ONLY IF SOLAR IS BACK-FED)
CODE REF: NEC 705.12(D) & NEC 690.59

WARNING
POWER SOURCE OUTPUT
CONNECTION. DO NOT
RELOCATE THIS
OVERCURRENT DEVICE

LABEL- 7:
LABEL LOCATION:
MAIN SERVICE PANEL (ONLY IF SOLAR IS BACK-FED)
SUBPANEL (ONLY IF SOLAR IS BACK-FED)
CODE REF: NEC 705.12(B)(3)(2)

**SOLAR PV SYSTEM EQUIPPED
WITH RAPID SHUTDOWN**

TURN RAPID SHUTDOWN
SWITCH TO THE
"OFF" POSITION TO
SHUT DOWN PV SYSTEM
AND REDUCE
SHOCK HAZARD
IN THE ARRAY

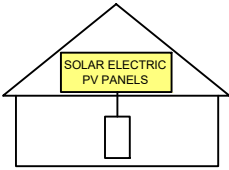

LABEL- 8:
LABEL LOCATION:
AC DISCONNECT
CODE REF: IFC 605.11.3.1(1) & NEC 690.56(C)

**RAPID SHUTDOWN SWITCH
FOR SOLAR PV SYSTEM**

LABEL- 9:
LABEL LOCATION:
AC DISCONNECT
CODE REF: NEC 690.56(C)(2)

**PHOTOVOLTAIC
AC DISCONNECT**

LABEL- 10:
LABEL LOCATION:
AC DISCONNECT
CODE REF: NEC 690.13(B)

**PHOTOVOLTAIC
DC DISCONNECT**

LABEL- 11:
LABEL LOCATION:
INVERTER
CODE REF: NEC 690.13(B)

**PHOTOVOLTAIC
AC DISCONNECT**
NOMINAL OPERATING AC VOLATGE **240 V**
RATED AC OUTPUT CURRENT **32.00 A**

LABEL- 12:
LABEL LOCATION:
MAIN SERVICE PANEL
SUBPANEL
AC DISCONNECT
CODE REF: NEC 690.54

**INVERTER
AC DISCONNECT**
NOMINAL OPERATING AC VOLATGE **240 V**
RATED AC OUTPUT CURRENT **32.00 A**

LABEL- 13:
LABEL LOCATION:
INVERTER
CODE REF: NEC 690.54

MAXIMUM VOLTAGE **380 V**
MAXIMUM CIRCUIT CURRENT **30 A**
**MAXIMUM RATED OUTPUT
CURRENT OF THE CHARGE
CONTROLLER OR DC-TO-DC
CONVERTER (IF INSTALLED)**

LABEL- 14:
LABEL LOCATION:
INVERTER
CODE REF: NEC 690.53

**MAIN PHOTOVOLTAIC
SYSTEM DISCONNECT**

LABEL- 15:
LABEL LOCATION:
MAIN SERVICE DISCONNECT (ONLY IF MAIN SERVICE DISCONNECT IS PRESENT)
CODE REF: NEC 690.13(B)

PRODUCTION METER

LABEL- 16:
LABEL LOCATION:
PRODUCTION METER (ONLY IF PRODUCTION METER IS USED)

NOTE:

** ELECTRICAL DIAGRAM SHOWN IS FOR LABELING PURPOSES ONLY. NOT AN ACTUAL REPRESENTATION OF EQUIPMENT AND CONNECTIONS TO BE INSTALLED. LABEL LOCATIONS PRESENTED MAY VARY DEPENDING ON TYPE OF INTERCONNECTION METHOD AND LOCATION PRESENTED ELECTRICAL DIAGRAM PAGE. **

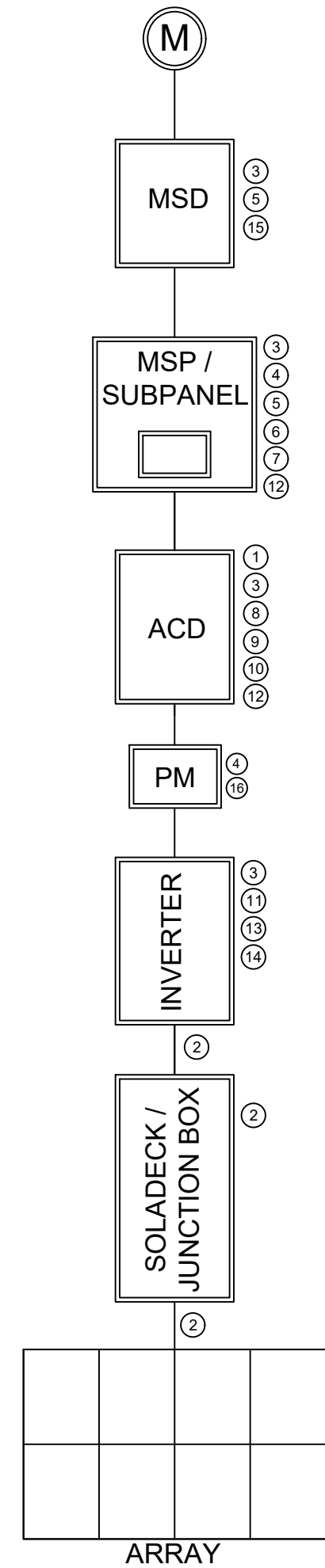

REVISIONS		
DESCRIPTION	DATE	REV
INITIAL	07/01/2022	
MSP LOCATION CHANGE	07/14/2022	A
TRENCH ROUTE CHANGE	08/24/2022	B

SIGNATURE WITH SEAL

DATE: 07/14/2022

PROJECT NAME & ADDRESS

**DEVON DODD
RESIDENCE**

2200 SHERIFF JOHNSON RD
LILLINGTON, NC 27546

DC SIZE: 7.590 KW
AC SIZE: 7.600 KW

SHEET NAME
LABELS

SHEET SIZE
**ANSI B
11" X 17"**

SHEET NUMBER
PV-6



CAUTION

POWER TO THIS BUILDING IS ALSO SUPPLIED FROM MULTIPLE SOURCES OF POWER WITH SAFETY DISCONNECTS AS SHOWN:

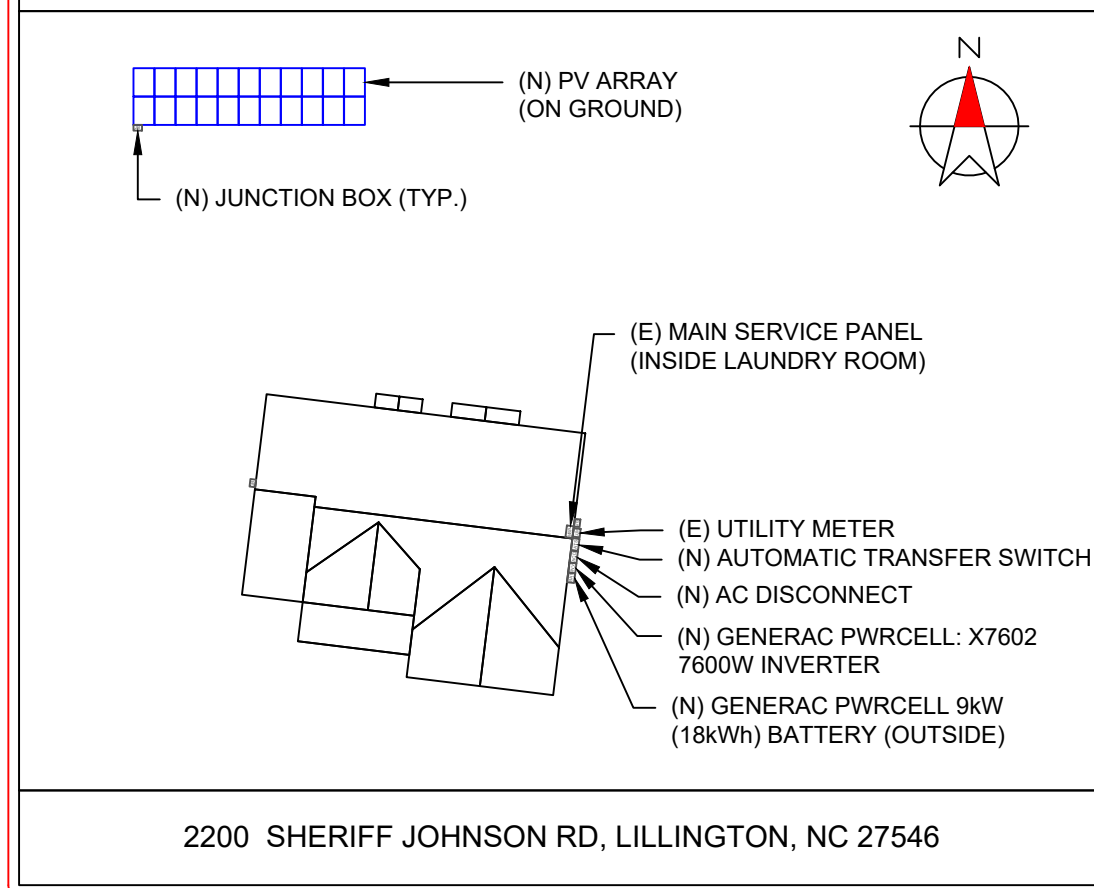

DIRECTORY

PERMANENT PLAQUE OR DIRECTORY PROVIDING THE LOCATION OF THE SERVICE DISCONNECTING MEANS AND THE PHOTOVOLTAIC SYSTEM.

(ALL PLAQUES AND SIGNAGE WILL BE INSTALLED AS OUTLINED WITHIN: NEC 690.56(B)&(C), [NEC 705.10])

LABELING NOTES:

1. LABELS CALLED OUT ACCORDING TO ALL COMMON CONFIGURATIONS. ELECTRICIAN TO DETERMINE EXACT REQUIREMENTS IN THE FIELD PER CURRENT NEC AND LOCAL CODES AND MAKE APPROPRIATE ADJUSTMENTS.
2. LABELING REQUIREMENTS BASED ON THE 2017 NATIONAL ELECTRIC CODE, OSHA STANDARD 19010.145, ANSI Z535.
3. MATERIAL BASED ON THE REQUIREMENTS OF THE AUTHORITY HAVING JURISDICTION.
4. LABELS TO BE OF SUFFICIENT DURABILITY TO WITHSTAND THE ENVIRONMENT INVOLVED [NEC 110.21]
5. LABELS TO BE A MINIMUM LETTER HEIGHT OF 3/8", WHITE ON RED BACKGROUND; REFLECTIVE, AND PERMANENTLY AFFIXED [IFC 605.11.1.1]

REVISIONS

DESCRIPTION	DATE	REV
INITIAL	07/01/2022	
MSP LOCATION CHANGE	07/14/2022	A
TRENCH ROUTE CHANGE	08/24/2022	B

SIGNATURE WITH SEAL

DATE: 07/14/2022

PROJECT NAME & ADDRESS

DEVON DODD
RESIDENCE
2200 SHERIFF JOHNSON RD
LILLINGTON, NC 27546

DC SIZE: 7.590 KW
AC SIZE: 7.600 KW

SHEET NAME

PLACARD

SHEET SIZE

ANSI B
11" X 17"

SHEET NUMBER

PV-7

1-10 11-20 21-30 31-40 41-50 51-60

POWER OPTIMIZER CHART

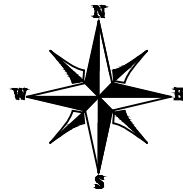

1
2
3
4
5
6
7
8
9
10

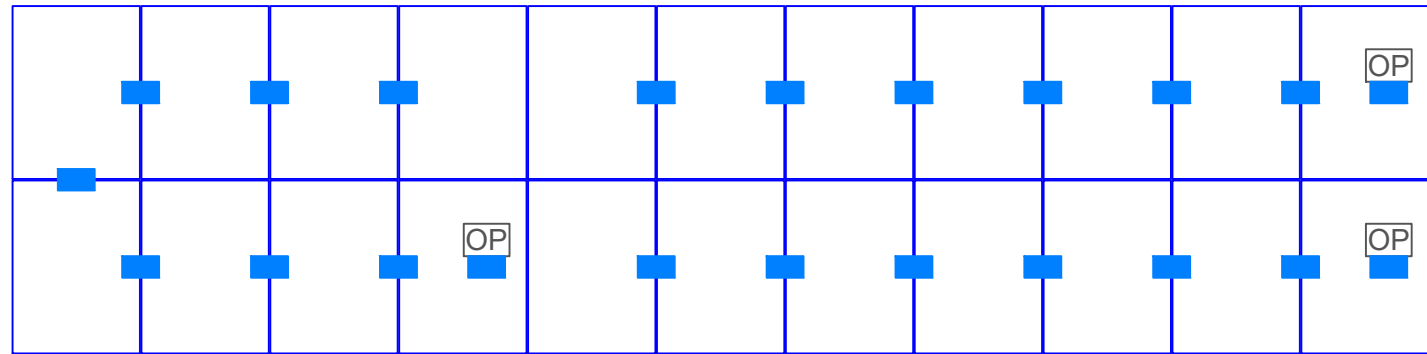

REVISIONS

DESCRIPTION	DATE	REV
INITIAL	07/01/2022	
MSP LOCATION CHANGE	07/14/2022	A
TRENCH ROUTE CHANGE	08/24/2022	B

SIGNATURE WITH SEAL

DATE: 07/14/2022

PROJECT NAME & ADDRESS

DEVON DODD
RESIDENCE
2200 SHERIFF JOHNSON RD
LILLINGTON, NC 27546

DC SIZE: 7.590 KW
AC SIZE: 7.600 KW

SHEET NAME
POWER
OPTIMIZER CHART

SHEET SIZE

ANSI B
11" X 17"

SHEET NUMBER

PV-8

MSE PERC 60

MISSION SOLAR ENERGY

345W

Class leading power output -0 to +3%

Positive Power Tolerance

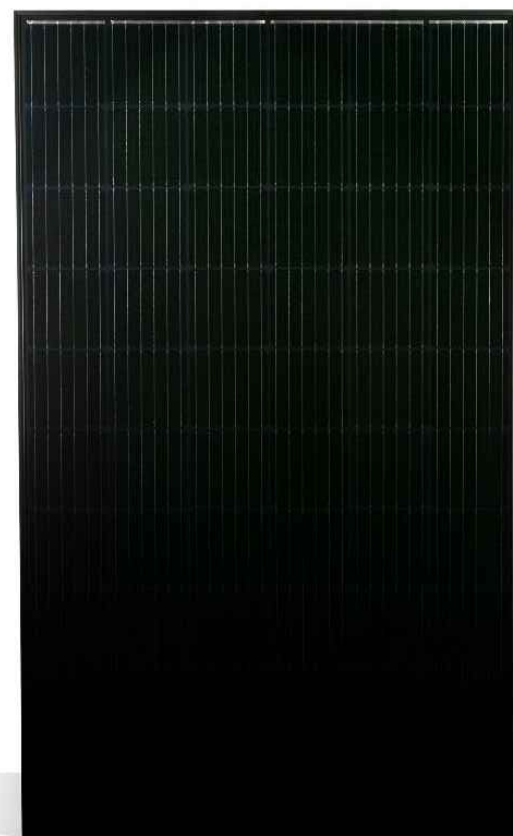

True American Quality True American Brand

Mission Solar Energy is headquartered in San Antonio, Texas, where we manufacture our modules. We produce American, high quality solar modules ensuring the highest in-class power output and best in-class reliability. Our product line is tailored for residential, commercial and utility applications. Every Mission Solar Energy solar module is certified and surpasses industry standard regulations, proving excellent performance over the long term.

Demand the best. Demand Mission Solar Energy.



Certified Reliability

- Tested to UL 61730 & IEC Standards
- PID resistant
- Resistance to salt mist corrosion



Advanced Technology

- 6 Busbar
- Passivated Emitter Rear Contact
- Ideal for all applications



Extreme Weather Resilience

- Up to 5,600 Pa front load & 5,631 Pa back load
- Tested load to UL 61730
- 40 mm frame



BAA Compliant for Government Projects

- Buy American Act
- American Recovery & Reinvestment Act

CERTIFICATIONS

CEC



UL 61730 / IEC 61215 / IEC 61730 / IEC 61701

If you have questions or concerns about certification of our products in your area, please contact Mission Solar Energy.



Class Leading
340-350W

MSE PERC 60

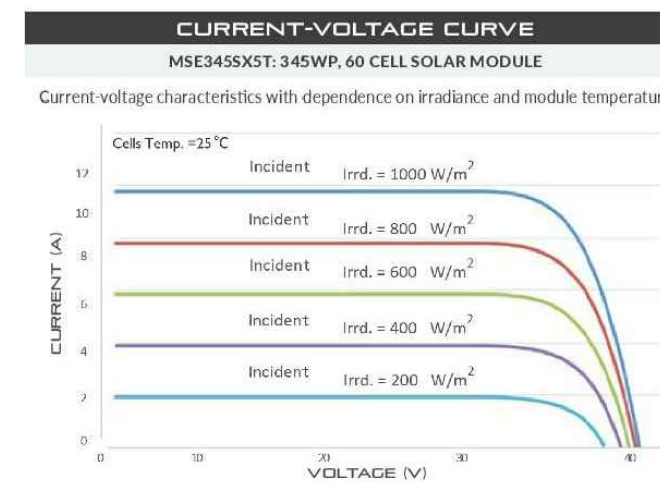
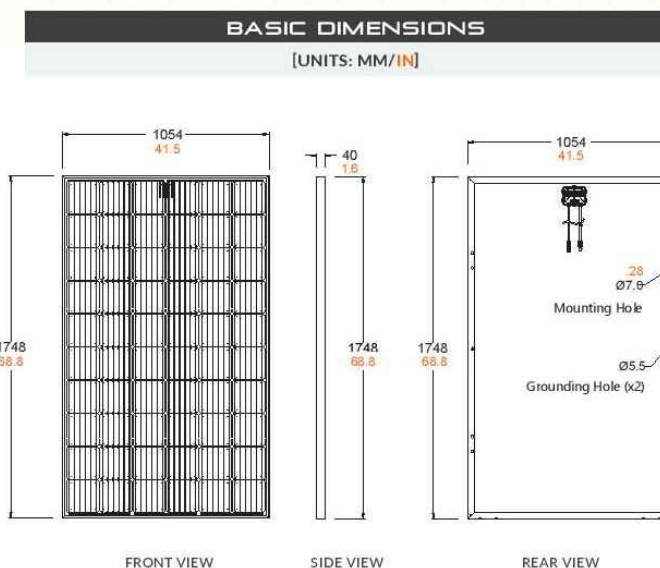

CERTIFICATIONS AND TESTS

Standard	Test Results
IEC	61215, 61730, 61701
UL	61730



CEC



Mission Solar Energy

8303 S. New Braunfels Ave., San Antonio, Texas 78235
www.missionsolar.com | info@missionsolar.com

ELECTRICAL SPECIFICATION

PRODUCT TYPE	MSE345SX5T (xxx = P _{max})	340	345	350
Power Output	P _{max} W _p	340	345	350
Module Efficiency	%	18.5	18.7	19.0
Tolerance	%	0/+3	0/+3	0/+3
Short Circuit Current	I _{sc} V	10.86	10.92	10.97
Open Circuit Voltage	V _{oc} A	40.82	41.00	41.18
Rated Current	I _{mp} V	10.24	10.34	10.44
Rated Voltage	V _{mp} V	33.20	33.37	33.52
Fuse Rating	A	20	20	20
System Voltage	V	1,000	1,000	1,000

TEMPERATURE COEFFICIENTS

Normal Operating Cell Temperature (NOCT)	44.43°C (±3.7%)
Temperature Coefficient of P _{max}	-0.361%/°C
Temperature Coefficient of V _{oc}	-0.262%/°C
Temperature Coefficient of I _{sc}	0.039%/°C

OPERATING CONDITIONS

Maximum System Voltage	1,000Vdc
Operating Temperature Range	-40°C (-40°F) to +85°C (185°F)
Maximum Series Fuse Rating	20A
Fire Safety Classification	Type 1
Front & Back Load (UL Standard)	Up to 5,600 Pa front and 5,631 Pa back load, Tested to UL 61730
Hail Safety Impact Velocity	25mm at 23 m/s

MECHANICAL DATA

Solar Cells	P-type mono-crystalline silicon
Cell Orientation	60 cells (6x10)
Module Dimension	1748mm x 1054mm x 40mm
Weight	20.3 kg (44.8 lbs.)
Front Glass	3.2mm, tempered, low-iron, anti-reflective
Frame	Anodized
Encapsulant	Ethylene vinyl acetate (EVA)
Junction Box	Protection class IP67 with 3 bypass-diodes
Cable	1.0m, Wire 4mm ² (12AWG)
Connector	Staubli PV-KBT4/6II-UR and PV-KST4/6II-UR, MC4, Renhe 05-8

SHIPPING INFORMATION

Container Feet	Ship To	Pallet	Panels	345 W Bin
53'	Most States	34	884	304.98 kW
Double Stack	CA	28	728	251.16 kW

PALLET [26 PANELS]

Weight	Height	Width	Length
1263 lbs. (573 kg)	47.5 in (120.65 cm)	46 in (116.84 cm)	70.25 in (178.43 cm)



REVISIONS

DESCRIPTION	DATE	REV
INITIAL	07/01/2022	
MSP LOCATION CHANGE	07/14/2022	A
TRENCH ROUTE CHANGE	08/24/2022	B

SIGNATURE WITH SEAL

DATE: 07/14/2022

PROJECT NAME & ADDRESS

DEVON DODD
RESIDENCE
2200 SHERIFF JOHNSON RD
LILLINGTON, NC 27546

DC SIZE: 7.590 KW
AC SIZE: 7.600 KW

SHEET NAME
EQUIPMENT SPECIFICATION

SHEET SIZE

ANSI B
11" X 17"

SHEET NUMBER

PV-9

GENERAC

SnapRS™

Inline Disconnect Switch
Model #: RS801 (Ordering SKU: APKE00011)



Generac SnapRS are a simple way to satisfy rapid shutdown compliance for solar + storage systems. Generac SnapRS are 2017/2020 NEC 690.12 compliant, don't require any extra hardware to mount, and need no pairing or fussy digital communications.

FEATURES & BENEFITS

- Fast, easy, and simple to install
- One SnapRS device per PV module
- Achieves PVRSS Compliance
- Low cost, high efficiency solution

SYSTEM DESIGN

Snap a Generac SnapRS disconnect device (RS) to the negative lead (-) of each module in the solar array for simple module-level rapid shutdown compliance. SnapRS devices isolate array voltage when a rapid shutdown is initiated at a PWRcell™ Inverter. When rapid shutdown is initiated, SnapRS units isolate each PV module in the array, reducing array voltage to <80V in seconds.

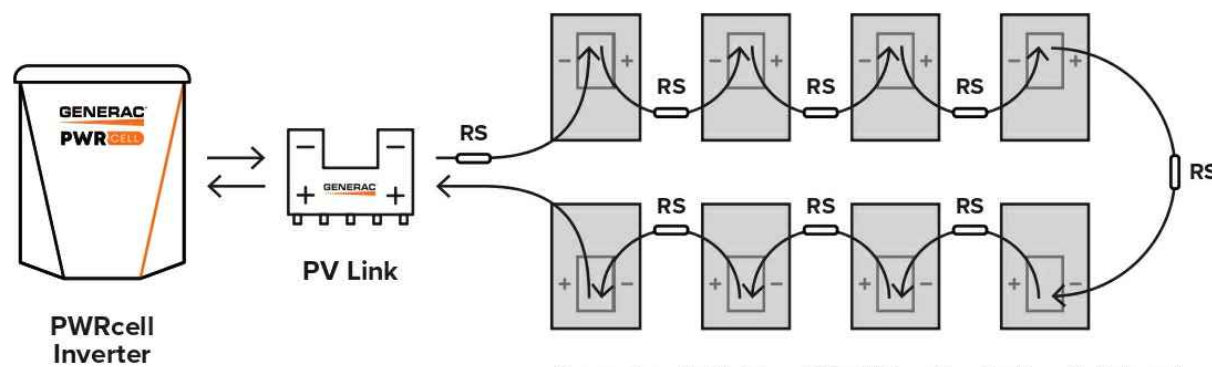

Diagram is applicable for most 60 cell PV modules. Modules with higher cell count may require a different arrangement. Contact Generac for more details.

Specifications

SnapRS™ (APKE00011)	
PV MODULE MAX VOC:	75 V
EFFICIENCY:	99.8%*
MAX INPUT CURRENT:	13 A
MAX STC ISC OF STRING:	10.4 A
MAX TOTAL QTY IN SUBSTRING:	10
SHUTDOWN TIME:	< 10 Seconds
ENCLOSURE RATING:	NEMA 6P
OPERATING TEMPERATURE - FAHRENHEIT (CELSIUS):	-40 to 158 °F (-40 to 70 °C)
CERTIFICATIONS:	UL1741
PROTECTIONS:	PVRSE
WEIGHT - LB (KG):	0.17 (0.08)
DIMENSIONS, L x W x H - IN (MM):	7" x 1" x 1" (177.8 x 25.4 x 25.4)
WARRANTY:	25 Years

*When used with a 50V panel

Connect one SnapRS device to the negative lead of each PV module in the PV Link controlled array for complete PV Rapid shutdown performance



Generac Power Systems, Inc.
S45 W29290 Hwy. 59, Waukesha, WI 53189
www.Generac.com | 888-GENERAC (436-3722)
A0000528183 REV E

©2021 Generac Power Systems. All rights reserved.
Specifications are subject to change without notice.

GENERAC



REVISIONS

DESCRIPTION	DATE	REV
INITIAL	07/01/2022	
MSP LOCATION CHANGE	07/14/2022	A
TRENCH ROUTE CHANGE	08/24/2022	B

SIGNATURE WITH SEAL

DATE: 07/14/2022

PROJECT NAME & ADDRESS

DEVON DODD
RESIDENCE
2200 SHERIFF JOHNSON RD
LILLINGTON, NC 27546

DC SIZE: 7.590 KW
AC SIZE: 7.600 KW

SHEET NAME
EQUIPMENT
SPECIFICATION

SHEET SIZE

ANSI B
11" X 17"

SHEET NUMBER

PV-10

GENERAC

PV Link™

2500W MPPT Substring Optimizer
Model #: S2502 (Ordering SKU: APKE00010)



PV Link is the simple solar optimizer for quick installation and long-lasting performance. Connect PV modules to each PV Link to overcome shading and challenging roof lines.

FEATURES & BENEFITS

- Fast, simple installation
- Lower failure risk than module-level optimizers
- 2017/2020 NEC rapid shutdown compliant with SnapRS™
- Quick connections with MC4 connectors
- Exports up to 2500W
- Compatible with PWRcell™ Inverters
- Cost-effective solution for high-performance PV
- Ground-fault protection

SINGLE-STRING PV ARRAY WITH SnapRS DEVICES

Where PV module-level rapid shutdown is required (NEC 690.12), a SnapRS device (RS) is installed to negative (-) lead of each PV module.

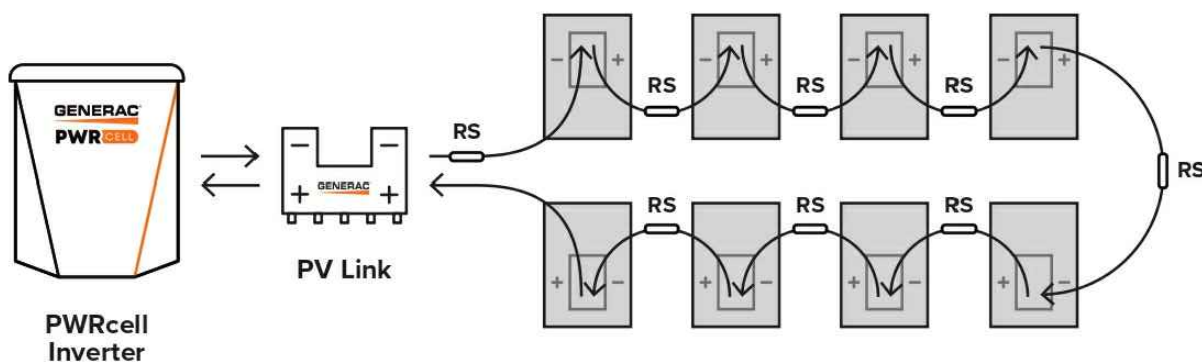

Diagram is applicable for most 60 cell PV modules. Modules with higher cell count may require a different arrangement. Contact Generac for more details.

Specifications

PV Link™ (APKE00010)	
RATED POWER*:	2500W
PEAK EFFICIENCY:	99%
MPPT VOLTAGE RANGE:	60-360 VMP
MAX INPUT VOLTAGE:	420 VOC; max when cold
MAX OUTPUT:	420 VOC
NOMINAL OUTPUT (REbus™):	380 VDC
MAX OUTPUT CURRENT (CONTINUOUS):	8 A
MAX OUTPUT CURRENT (FAULT):	10 A
MAX INPUT CURRENT (CONTINUOUS):	13 A @ 50°C, 10 A @ 70°C
MAX INPUT SHORT CIRCUIT CURRENT (ISC):	18 A
STANDBY POWER:	<1 W
PROTECTIONS:	Ground-fault, Arc-fault (Arc-fault Type 1 AFCl, Integrated), PVRSE
MAX OPERATING TEMP: FAHRENHEIT (CELSIUS):	158 °F (70 °C)
SYSTEM MONITORING:	PWRview™ Web Portal and Mobile App
ENCLOSURE:	Type 4X
WEIGHT - LB (KG):	7.3 lb (3.3 kg)
DIMENSIONS, L x W x H - IN (MM):	15.4" x 2" x 9.6" (391.2 x 50.8 x 243.8)
COMPLIANCE:	UL 1741, CSA 22.2
WARRANTY:	25 Years

*PV Link can tolerate higher than rated power at its input if Max Input Voltage and Short Circuit Current specifications are not exceeded



Generac Power Systems, Inc.
545 W29290 Hwy. 59, Waukesha, WI 53189
www.Generac.com | 888-GENERAC (436-3722)
A0000528162 REV D
©2020 Generac Power Systems. All rights reserved.
Specifications are subject to change without notice.



REVISIONS		
DESCRIPTION	DATE	REV
INITIAL	07/01/2022	
MSP LOCATION CHANGE	07/14/2022	A
TRENCH ROUTE CHANGE	08/24/2022	B

SIGNATURE WITH SEAL

DATE: 07/14/2022

PROJECT NAME & ADDRESS

DEVON DODD
RESIDENCE
2200 SHERIFF JOHNSON RD
LILLINGTON, NC 27546

DC SIZE: 7.590 KW
AC SIZE: 7.600 KW

SHEET NAME
EQUIPMENT
SPECIFICATION

SHEET SIZE
ANSI B
11" X 17"

SHEET NUMBER
PV-11

GENERAC® PWRCELL

7.6kW 1Ø PWRcell Inverter with CTs
Model #: X7602 (Ordering SKU: APKE00014)
11.4 kW 3Ø PWRcell Inverter with CTs
Model #: X11402 (Ordering SKU: APKE00013)



Solar + storage is simple with the Generac PWRcell™ Inverter. This bi-directional, REbus™-powered inverter offers a simple, efficient design for integrating smart batteries with solar. Ideal for self-supply, backup power, zero-export and energy cost management, the PWRcell Inverter is the industry's most feature-rich line of inverters, available in single-phase and three-phase models.

FEATURES & BENEFITS

- Single inverter for grid-tied solar with smart battery integration
- Simplified system design: No autotransformer or battery inverter needed
- User-selectable modes for backup power, self-supply, time-of-use, zero-import and export limiting
- Free system monitoring included via PWRview™ Web Portal and Mobile App

AC OUTPUT/GRID-TIE	MODEL X7602	MODEL X11402
CONT. GRID-TIED AC POWER @ 50°C (122°F):	7600 W	11400 W
AC OUTPUT VOLTAGE:	120/240, 1Ø VAC	120/208, 3Ø VAC
AC FREQUENCY:	60 Hz	
MAXIMUM CONTINUOUS OUTPUT CURRENT:	32 A, RMS	
GROUND-FAULT ISOLATION DETECTION:	Included	
CHARGE BATTERY FROM AC:	Yes	
THD (CURRENT):	< 2%	
TYPICAL NIGHTTIME POWER CONSUMPTION:	< 7 W	

DC INPUT	MODEL X7602	MODEL X11402
DC INPUT VOLTAGE RANGE:	360-420 VDC	
NOMINAL DC BUS VOLTAGE:	380 VDC	
DC DISTRIBUTION INPUT BREAKERS:	4 x 2P30 A	
MAX INPUT CURRENT PER DC INPUT:	30 A	
REVERSE-POLARITY PROTECTION:	Yes	
TRANSFORMERLESS, UNGROUNDED:	Yes	
TYPICAL NIGHTTIME POWER CONSUMPTION:	< 7 W	
DC BUS EXPORT FUSES (+/-):	40 A	
2-POLE DISCONNECTION:	Yes	

AC OUTPUT/ISLANDED	MODEL X7602	MODEL X11402
MAX. CONT. ISLANDED AC POWER WITHOUT AN EXTERNAL TRANSFER SWITCH ¹ :	7600 W	
MAX. CONT. ISLANDED AC POWER W/ EXTERNAL TRANSFER SWITCH AND SINGLE 6 MODULE BATTERY CABINET ² :	9000 W	
MAX. CONT. ISLANDED AC POWER W/ EXTERNAL TRANSFER SWITCH AND 2 BATTERY CABINETS (8 MODULES MINIMUM) ² :	11000 W	9600 W-11000 W*
PEAK MOTOR STARTING CURRENT (2 SEC):	50 A, RMS	
AC BACKUP OUTPUT VOLTAGE:	120/240, 1Ø VAC	120/208, 1Ø VAC
AC FREQUENCY:	60 Hz	
THD (VOLTAGE):	< 2%	
ALLOWABLE SPLIT PHASE IMBALANCE:	Up to 30%	

¹When islanded, continuous power output is restricted to 7.6kW unless backup power is routed through an external transfer switch.
²Peak performance, values provided for 40°C (104°F).
^{*}In Island mode X11402 protected loads only supply 2 phases 120 VAC L-N, 208 L-L which results in lower power than in grid tied 3 phase mode. The low value of the range is for full L-L loading while high value of the range is full L-N loading

Specifications

FEATURES AND MODES

ISLANDING ⁴ :	Yes
GRID SELL:	Yes
SELF CONSUMPTION:	Yes
PRIORITIZED CHARGING FROM RENEWABLES:	Yes
GRID SUPPORT - ZERO EXPORT:	Yes
ESS PCS OPERATION MODES (IMPORT ONLY, EXPORT ONLY):	Yes

ADDITIONAL FEATURES

SUPPORTED COMMUNICATION INTERFACES:	REbus™, CANbus, Ethernet
SYSTEM MONITORING:	PWRview™ Web Portal and Mobile App
BACKUP LOADS DISCONNECT ⁵ :	Yes, 50 A Circuit Breaker
INVERTER BYPASS SWITCH:	Automatic
WARRANTY:	10 Years

STANDARDS COMPLIANCE

SAFETY:	UL 1741 SA, CSA 22.2, UL 1998
GRID CONNECTION STANDARDS:	IEEE 1547, Rule 21, Rule 14H, CSIP, UL 1741 PCS CRD (Import Only, Export Only)
EMISSIONS:	FCC Part 15 Class B

DIMENSIONS AND INSTALLATION SPECIFICATIONS

ENCLOSURE KNOCKOUTS - QTY, SIZE - IN (MM):	6 x Combo 3/4" x 1" (19 x 25.4) 7 x Combo 1/2" x 3/4" (12.7 x 19)
DIMENSIONS L x W x H - IN (MM):	24.5" x 19.25" x 8" (622.3 x 488.9 x 203.2)
WEIGHT - LB (KG):	62.7 (28.4)
COOLING:	Forced convection
AUDIBLE NOISE:	< 40 dBA
OPERATING TEMPERATURE - FAHRENHEIT (CELSIUS):	-4 to 122 °F (-20 to 50 °C) ⁶
ENCLOSURE TYPE:	Type 3R

INSTALLATION GUIDELINES

BATTERY TYPES SUPPORTED:	PWRcell™ Battery
MODULE STRING SIZE PER PV LINK OPTIMIZER:	Varies, refer to PV Link Installation Manual
MAXIMUM RECOMMENDED DC POWER FROM PV ⁶ :	10 kW (1Ø), 15 kW (3Ø)

⁴3Ø inverters offer islanding for 1Ø loads.
⁵Includes ambient temperature rising from inverter operation. Reduced power at extreme temperatures.
Specifications listed in this document are achieved with firmware version 13310 or greater. Confirm inverter has latest firmware to ensure full performance.
⁶Values provided for PV-only or small storage systems. Additional PV power is permissible if sufficient battery storage capacity is installed.

Generac Power Systems, Inc.
S45 W29290 Hwy. 59, Waukesha, WI 53189
www.Generac.com | 888-GENERAC (436-3722)

A0000528185 REV G

©2020 Generac Power Systems. All rights reserved.
Specifications are subject to change without notice.

GENERAC®



REVISIONS

DESCRIPTION	DATE	REV
INITIAL	07/01/2022	
MSP LOCATION CHANGE	07/14/2022	A
TRENCH ROUTE CHANGE	08/24/2022	B

SIGNATURE WITH SEAL

DATE: 07/14/2022

PROJECT NAME & ADDRESS

DEVON DODD
RESIDENCE
2200 SHERIFF JOHNSON RD
LILLINGTON, NC 27546

DC SIZE: 7.590 KW
AC SIZE: 7.600 KW

SHEET NAME
EQUIPMENT
SPECIFICATION

SHEET SIZE

ANSI B
11" X 17"

SHEET NUMBER

PV-12

Specifications

PWRcell™ BATTERY CONFIGURATIONS	M3	M4	M5	M6
BATTERY MODULES:	3	4	5	6
USABLE ENERGY ¹ :	9 kWh	12 kWh	15 kWh	18 kWh
NOMINAL CONT. AC POWER ^{1,2} :	3.4 kW	4.5 kW	5.6 kW	6.7 kW
MAX. AC POWER ^{1,3} :	4.5 kW	6 kW	7.5 kW	9 kW
NOMINAL CONT. DC (CHARGE/DISCHARGE) - A:	11.6	15.5	19.4	23.3
PEAK MOTOR STARTING CURRENT (2 SEC) - A, RMS:	25	33	42	50
COMPATIBLE BATTERY MODULES ⁴ :	Generac PWRcell EX 3.0 kWh, Generac PWRcell DCB 3.0 kWh, Generac PWRcell DCB 2.85 kWh			
REbus™ VOLTAGE - INPUT/OUTPUT:	360-420 VDC			
NOMINAL VOLTAGE:	380 VDC			
DC-DC ROUND-TRIP EFFICIENCY:	96.5%			
MAXIMUM AMBIENT OPERATING TEMPERATURE:	14 TO 122 °F (-10 TO 50 °C)			
OPTIMAL AMBIENT OPERATING TEMPERATURE:	41 TO 104 °F (5 TO 40 °C)			
MAXIMUM INSTALLATION ALTITUDE - FT (M):	6560 (2000)			
DIMENSIONS, L x W x H - IN (MM):	22" x 10" x 68" (559 x 254 x 1727)			
WEIGHT, ENCLOSURE - LB (KG):	115 (52)			
WEIGHT, INSTALLED W/ DCB MODULES - LB (KG):	280 (127)	335 (152)	390 (177)	445 (202)
WEIGHT, INSTALLED W/ EX MODULES - LB (KG):	287 (130)	344 (156)	401 (182)	459 (208)
WEIGHT, ACCESSORY MOUNTING HARDWARE - LB (KG):	21 (10)			
ENCLOSURE TYPE:	Type 3R			
WARRANTY - LI-ION MODULES:	10 Years, (7.56MWh)			
WARRANTY - ELECTRONICS AND ENCLOSURE:	10 Years			
COMMUNICATION PROTOCOL:	REbus™ DC Nanogrid™			
SEISMIC RATING:	IEEE 693-2018 (HIGH)			
COMPLIANCE:	UL 9540, UL 9540A ⁵ , UL 1973, UL 1642, CSA 22.2 #107.1			

¹Assumes use of 3.0kWh battery module. ²Average AC power over a complete discharge cycle. ³Values provided for 40°C (104°F). ⁴All PWRcell battery models used in a PWRcell Battery Cabinet must be the same model. Do NOT combine module SKUs in a single battery cabinet. ⁵Meets residential indoor requirement as per UL9540A ed 4 in PWRcell OR M* DCB configuration.
 Note: Charge/discharge rate may be reduced at temperature extremes

PWRcell ACCESSORIES

Inside of the PWRcell Battery Cabinet, battery modules are stacked two deep on three levels, allowing for up to six modules to be connected in series. You can upgrade an existing PWRcell Battery Cabinet by adding Battery Modules and a Module Spacer (APKE00008). A Module Spacer is only required for battery configurations with an odd number of modules (i.e. 3 or 5).

Generac offers a convenient PWRcell Battery Upgrade Kit (APKE00009) to help replace lost or misplaced hardware.

Note: When adding modules, be sure all modules within a cabinet are the same model (i.e., EX or DCB). Instructions are provided in product manual.

Generac Power Systems, Inc.
 S45 W29290 Hwy. 59, Waukesha, WI 53189
www.Generac.com | 888-GENERAC (436-3722)

A0000949454 REV F

©2021 Generac Power Systems. All rights reserved.
 Specifications are subject to change without notice.



GENERAC

PWRCELL

OUTDOOR RATED BATTERY

PWRcell Outdoor Rated Battery Cabinet (Ordering SKU: APKE00028)
 3.0kWh PWRcell DCB Battery Module
 Model #: BJ-DCB05ZKBG (Ordering SKU: G0080040)
 3.0kWh PWRcell EX Battery Module
 Model #: G0080001, G0080003

The PWRcell™ Outdoor Rated (OR) Battery Cabinet is a Type 3R smart battery enclosure that allows for a range of storage configurations to suit any need. DC-couple to Generac PWRzone solar, PWRgenerator, or AC-couple to a third party PV array. No other smart battery offers the power and flexibility of PWRcell.

PWRcell BATTERY CABINET DESIGN

The PWRcell Battery Cabinet allows system owners the flexibility to scale from an economical 9kWh to a massive 18kWh by installing additional battery modules to the PWRcell Battery Cabinet. An existing PWRcell Battery Cabinet can be upgraded with additional modules. Use the graphic below and the chart on the back of this sheet to understand what components you need for your chosen PWRcell configuration.

BATTERY CONFIGURATION GUIDE

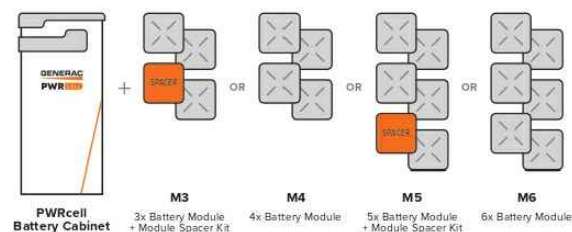

FEATURES & BENEFITS

- Best-in-class battery backup power
 - AC-couple to third party solar array
- Connect 2 PWRcell Battery Cabinets to a single PWRcell Inverter for up to 36kWh of usable storage
- Plug-and-play with all PWRcell products
- Time-of-use (TOU) and zero-export ready
- 3R cabinet for outdoor and indoor installations
- Floor standing or wall-mounted design

BATTERY CABINET ASSEMBLY

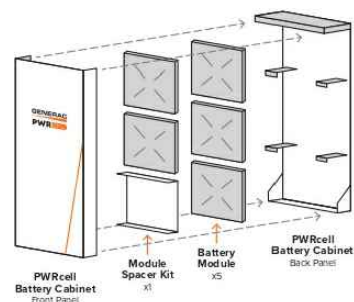

REVISIONS		
DESCRIPTION	DATE	REV
INITIAL	07/01/2022	
MSP LOCATION CHANGE	07/14/2022	A
TRENCH ROUTE CHANGE	08/24/2022	B

SIGNATURE WITH SEAL

DATE: 07/14/2022

PROJECT NAME & ADDRESS

DEVON DODD
 RESIDENCE
 2200 SHERIFF JOHNSON RD
 LILLINGTON, NC 27546

DC SIZE: 7.590 KW
 AC SIZE: 7.600 KW

SHEET NAME
 EQUIPMENT
 SPECIFICATION

SHEET SIZE
 ANSI B
 11" X 17"

SHEET NUMBER
 PV-13



GENERAC
PWRCELL
AUTOMATIC TRANSFER SWITCH

100A Non-Service Entrance Rated
 Model #: CXSC100A3
 UPC #: 696471081701

100A Service Entrance Rated
 Model #: CXSW100A3
 UPC #: 696471081718

200A Service Entrance Rated
 Model #: CXSW200A3
 UPC #: 696471081725



Specifications

SPECIFICATIONS	CXSC100A3	CXSW100A3	CXSW200A3
AMPS:	100	100	200
VOLTAGE	120/240 1Ø	120/240 1Ø	120/240 1Ø
LOAD TRANSITION TYPE (AUTOMATIC)	OPEN TRANSITION	OPEN TRANSITION SERVICE RATED	OPEN TRANSITION SERVICE RATED
ENCLOSURE TYPE	NEMA 3R	NEMA 3R	NEMA 3R
COMPLIANCE	UL 1008	UL 1008	UL 1008
WITHSTAND RATING (AMPS)	10,000	10,000	20,000
LUG RANGE	1/0 - #14	1/0 - #14	250 MCM - #6

DIMENSIONS		CXSC100A3	CXSW100A3	CXSW200A3
HEIGHT (IN/MM)	H1	17.24/437.9	17.24/437.9	26.75/679.4
	H2	20/508	20/508	30/762
WIDTH (IN/MM)	W1	12.5/317.5	12.5/317.5	10.5/266.7
	W2	14.6/370.8	14.6/370.8	13.5/342.9
DEPTH (IN/MM)		7.09/180.1	7.09/180.1	6.3/160.1
WEIGHT (LBS/KG)		20/9.07	22.5/10.21	39/17.69

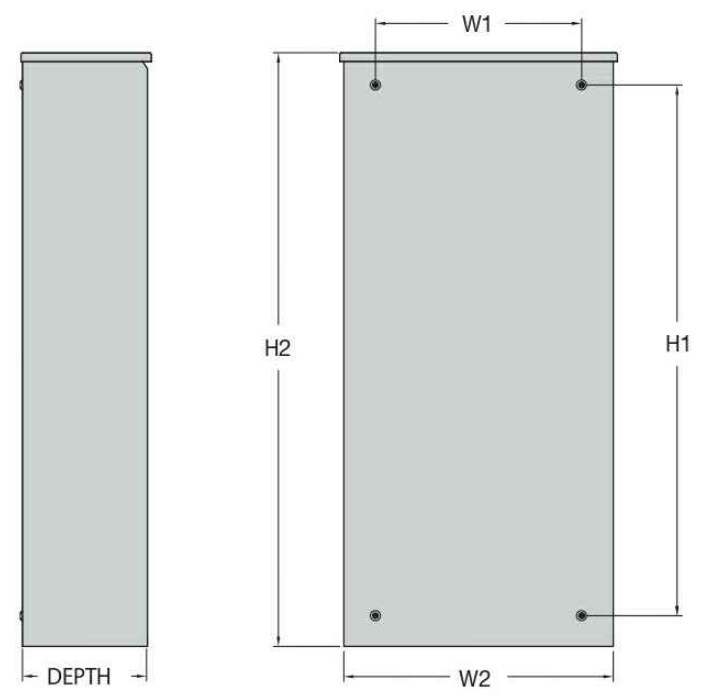

An integrated solar + storage system with load management for whole home coverage is made easy with the PWRcell™ Automatic Transfer Switch (ATS). Power the entire home and manage up to four individual HVAC (24 Vac controlled) loads with the PWRcell ATS. This built-in capability requires no additional hardware. When used in tandem with Generac Smart Management Modules (SMM) up to eight additional circuits can be controlled by the PWRcell Inverter. Make the most of your Generac solar + storage system with this comprehensive load management solution.

FEATURES & BENEFITS

- Unlock whole home backup power capability for PWRcell solar + storage systems
- Manage up to four HVAC systems, and an additional eight circuits with optional Smart Management Modules (SMMs)
- Aluminum type 3R enclosure with durable finish for indoor or outdoor installation
- Heavy Duty Generac Contactor is an ETL recognized device, designed for years of service and reliability

Generac Power Systems, Inc.
 S45 W29290 Hwy. 59, Waukesha, WI 53189
www.Generac.com | 888-GENERAC (436-3722)

A0000915134 REV A
 ©2020 Generac Power Systems. All rights reserved.
 Specifications are subject to change without notice.



REVISIONS		
DESCRIPTION	DATE	REV
INITIAL	07/01/2022	
MSP LOCATION CHANGE	07/14/2022	A
TRENCH ROUTE CHANGE	08/24/2022	B

SIGNATURE WITH SEAL

DATE: 07/14/2022

PROJECT NAME & ADDRESS

**DEVON DODD
 RESIDENCE**

2200 SHERIFF JOHNSON RD
 LILLINGTON, NC 27546

DC SIZE: 7.590 KW
 AC SIZE: 7.600 KW

SHEET NAME
**EQUIPMENT
 SPECIFICATION**

SHEET SIZE
**ANSI B
 11" X 17"**

SHEET NUMBER
PV-14

GENERAC

PWR MANAGER

Advanced Load Management
Model # G0080090



Add unbeatable flexibility and value to the PWRcell System by enabling whole home backup controlled via the user-friendly PWRview app. The PWRmanager enables data-driven efficient control of home loads to extend battery backup. This easy-to-install load management device integrates seamlessly with PWRcell, dramatically improving system performance.

FEATURES & BENEFITS

- Enhances PWRcell whole home backup
- Flexibility and reliability during outages
- Turn home loads on and off on-the-fly with PWRview app
- Control up to twelve 120 V circuits or six 240 V circuits + two thermostats
- Easy to install: no need for a new load panel

FEATURE	SPECIFICATIONS
NO. OF 120 V RELAYS	12
HVAC RELAYS	2
CURRENT RATING	60 Amps per relay
CONNECTIONS	WiFi, Ethernet
DIMENSIONS, L X W X H - IN (MM):	17.7" x 12.2" x 5.5" (449.58 x 309.88 x 139.7)
WEIGHT - LB (KG):	13.23 (5.2)
COMPLIANCE	UL-916, FCC Part 15 Class B, IC, Surge IEC 61000-4-5
ENCLOSURE	NEMA 3R
WIRE GAUGE	#14 to #6 AWG
OPERATING TEMPERATURE	-40°F to +122°F (-40°C to +50°C)
WARRANTY	10 YEAR LIMITED

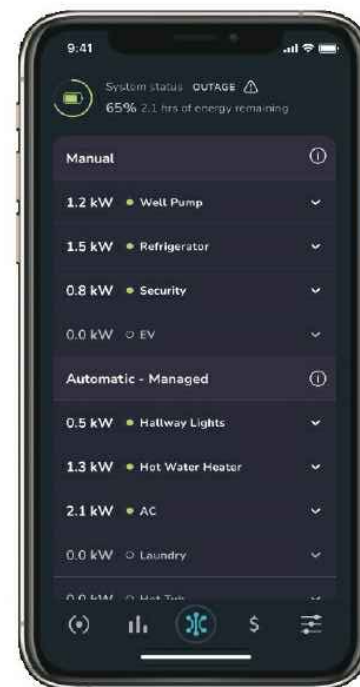

Generac Power Systems, Inc.
S45 W29290 Hwy. 59, Waukesha, WI 53189
www.Generac.com | 888-GENERAC (436-3722)

A0002198364 REV B

©2021 Generac Power Systems. All rights reserved.
Specifications are subject to change without notice.

GENERAC

REVISIONS		
DESCRIPTION	DATE	REV
INITIAL	07/01/2022	
MSP LOCATION CHANGE	07/14/2022	A
TRENCH ROUTE CHANGE	08/24/2022	B

SIGNATURE WITH SEAL

DATE: 07/14/2022

PROJECT NAME & ADDRESS

DEVON DODD
RESIDENCE
2200 SHERIFF JOHNSON RD
LILLINGTON, NC 27546

DC SIZE: 7.590 KW
AC SIZE: 7.600 KW

SHEET NAME
EQUIPMENT
SPECIFICATION

SHEET SIZE

ANSI B
11" X 17"

SHEET NUMBER

PV-15



SKY RACK 2.0 GROUND MOUNT (POST DRIVEN & BALLASTED)

Introducing the Sky-Rack 2.0 Ground Mount System. Our upgraded design increases the overall structural integrity of the assembly and provides more efficient installation techniques for rapid installation; while offering fixed or season adjustable options.

**Fixed Tilt System
5-45 Degrees**



**Season Adjustable
Manual: 15-60 Degrees**



**Season Adjustable
Motorized: 15-60 Degrees**



SKY-RACK 2.0 GROUND MOUNT FIXED TILT

www.sinclair-designs.com

REV A



WHY CHOOSE SDE?

No Middle-Man Distributors
No Commission Based Sales Representatives. You will work directly with our manufacturing plant; saving you time and money.

Our NABCEP certified designers and engineers can support you through every phase of your project. We offer the following support for free:

- Preliminary PV Designs & Proposals
- 3D Site Modeling & Production Reports
- Formal Structural Calculations for Permits
- Project BOM & Deployment Schedules



REVISIONS

DESCRIPTION	DATE	REV
INITIAL	07/01/2022	
MSP LOCATION CHANGE	07/14/2022	A
TRENCH ROUTE CHANGE	08/24/2022	B

SIGNATURE WITH SEAL

DATE: 07/14/2022

PROJECT NAME & ADDRESS

DEVON DODD
RESIDENCE
2200 SHERIFF JOHNSON RD
LILLINGTON, NC 27546

DC SIZE: 7.590 KW
AC SIZE: 7.600 KW

SHEET NAME
EQUIPMENT
SPECIFICATION

SHEET SIZE

ANSI B
11" X 17"

SHEET NUMBER

PV-16



PRODUCT AVAILABILITY

All racking systems are manufactured "in-house" from prime 11 gage grade 50 USA Steel. This allows us to control 100% of the production schedule and deploy your system ahead of the installation date. We inventory 1-2 Megawatts of racking product to maintain an average lead-time of 7-10 days.



Only 4x Main Components Required

- ***NEW Z-PURLIN-210 (Slots available for direct to module)
- ***NEW 4x9 C-CHANNEL POST (8-18 Feet Available)
- ***NEW SLR-TRUSS-105
- ***NEW SLR-STRUT-50

Minimal Hardware Required

- 2x 5/8-11 Serrated Flanged Bolts/Nuts
- 6x 1/2-13 Serrated Flanged Bolts/Nuts
- Custom Extrusion Panel Clamp Kits

Note: Higher wind load/snow load options are available. Formal site specific structural calculations available upon request.

APPLICATION	OPEN FIELD		
Tilt Angle	5-45 Degrees	Terrain	5 Degree E/W
Module Orientation	2 High Portrait	Wire Management	Included
Wind Load	115 MPH	Warranty	25 Years
Snow Load	60 PSF	Material	11GA G90 CHEM TREAT Steel
Ground Clearance	24in Standard (Customer Req)	Manufacturing	Made in Michigan, USA

SINGLE & DOUBLE PORTRAIT BALLASTED OPTIONS

Introducing the Vector 1.0 and Sky-Rack 2.0 Ballasted Ground Mount Systems. Our upgraded design increases the overall structural integrity of the assembly and provides more efficient installation techniques for rapid installation; while offering fixed or season adjustable options.

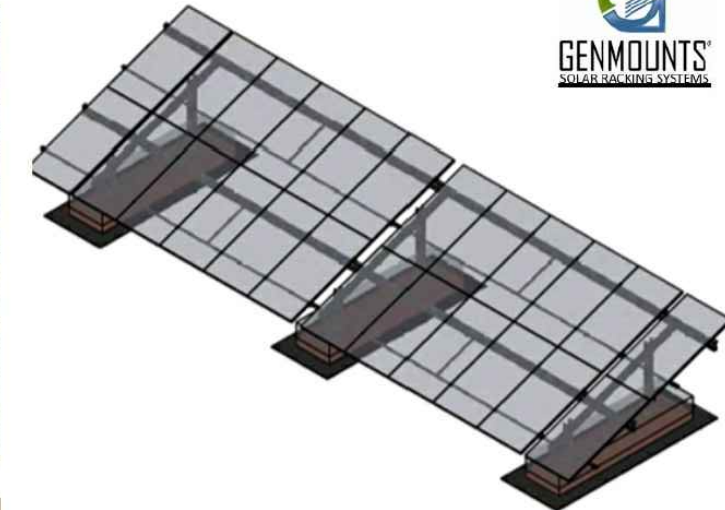

PRODUCT FEATURES

- MODULAR WITH QUICK ASSEMBLY
- STARTING SECTION ASSEMBLY INCLUDES 2 PRE-CAST BALLASTED POSTS, 2 N/S MEMBERS, 2 RAILS
- ADD-ON SECTION ASSEMBLY INCLUDES: 1 PRE-CAST BALLASTED POST, 1 N/S MEMBER, 2 RAILS
- MOUNTING STRUCTURE IS 100% HOT-DIPPED GALVANIZED METAL
- IDEAL FOR LARGE COMMERCIAL & UTILITY-SCALE INSTALLATIONS
- RUGGED, WEATHER RESISTANT DESIGN
- 10-YEAR GUARANTEE AGAINST MECHANICAL FAILURE (BREAKAGE) OF FRAME CONSTRUCTION
- NO GROUND PENETRATION



REVISIONS

DESCRIPTION	DATE	REV
INITIAL	07/01/2022	
MSP LOCATION CHANGE	07/14/2022	A
TRENCH ROUTE CHANGE	08/24/2022	B

SIGNATURE WITH SEAL

DATE: 07/14/2022

PROJECT NAME & ADDRESS

DEVON DODD
RESIDENCE
2200 SHERIFF JOHNSON RD
LILLINGTON, NC 27546

DC SIZE: 7.590 KW
AC SIZE: 7.600 KW

SHEET NAME
EQUIPMENT
SPECIFICATION

SHEET SIZE

ANSI B
11" X 17"

SHEET NUMBER

PV-17