

SCOPE OF WORK

TO INSTALL A SOLAR PHOTOVOLTAIC (PV) SYSTEM AT THE QUIGLEY RESIDENCE, LOCATED AT 3068 OLD STAGE ROAD NORTH, COATS, NORTH CAROLIN. THE POWER GENERATED BY THE PV SYSTEM WILL BE INTERCONNECTED WITH THE UTILITY GRID THROUGH THE EXISTING ELECTRICAL SERVICE EQUIPMENT. THE PV SYSTEM DOES NOT INCLUDE STORAGE BATTERIES.

SYSTEM RATING

5.53 kW DC STC
4.99 kW AC

EQUIPMENT SUMMARY

(13) SUNPOWER SPR-M425-H-AC PV MODULES
(13) SUNPOWER SPR-M425-H-AC [240V] PV INVERTERS
(108) (10 X 10.75') LINEAR FEET SUNPOWER INVISIMOUNT

SHEET INDEX

PV-0 COVER
PV-1 SITE MAP AND PV LAYOUT
PV1A RACKING PLAN
PV-2 STRING MAP AND MONITORING LAYOUT
PV-3 ELECTRICAL DIAGRAM
PV-4 EQ WALL & MOUNTING DETAIL
PV-5 SYSTEM LABELING DETAIL
PV-6 SITE DIRECTORY PLACARD
PV-7 SAFETY PLAN

GOVERNING CODES

2020 NATIONAL ELECTRICAL CODE
2015 INTERNATIONAL FIRE CODE
2018 NORTH CAROLINA STATE BUILDING CODE
UNDERWRITERS LABORATORIES (UL) STANDARDS
OSHA 29 CFR 1910.269

REVIEWED

By Ashton Johnson at 1:04 pm, Jun 06, 2022

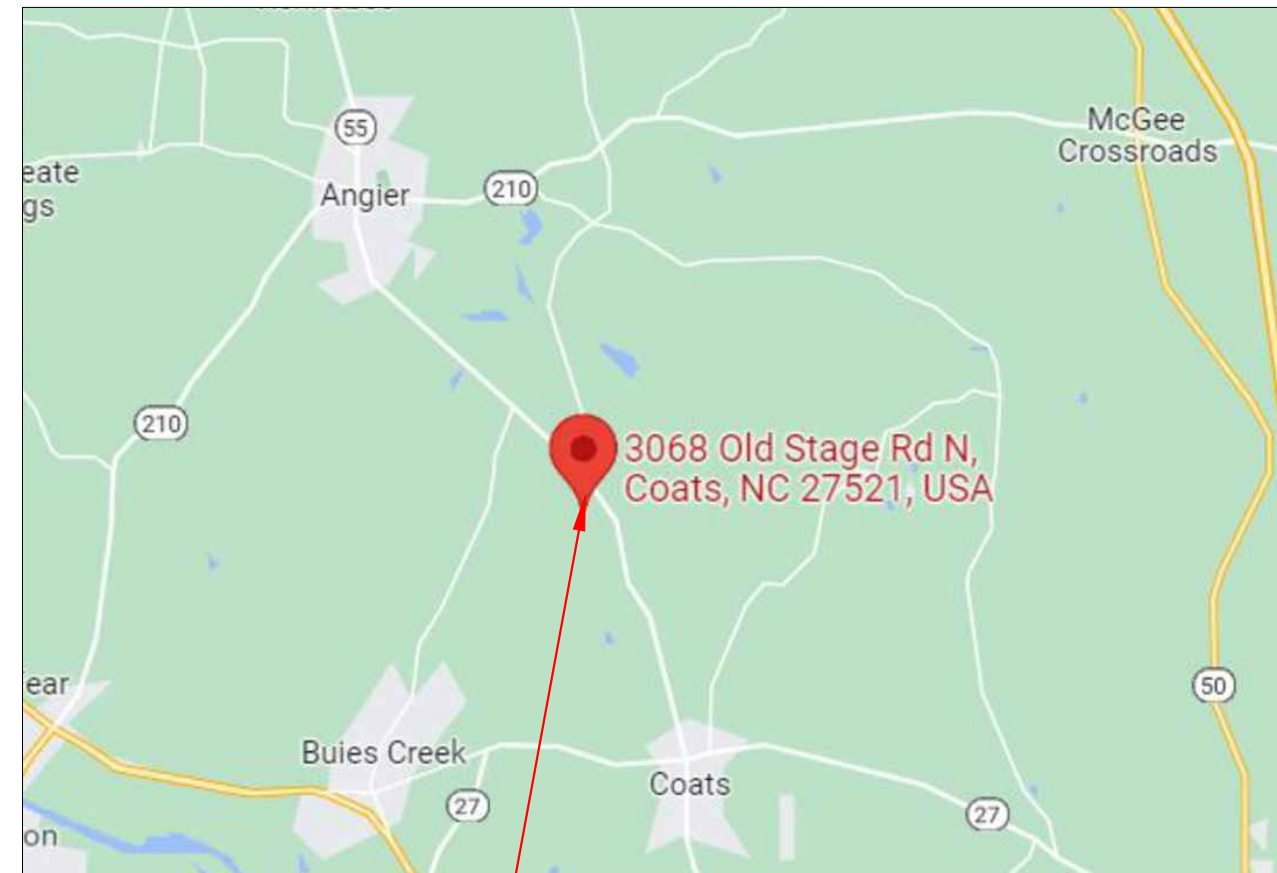

PROJECT LOCATION

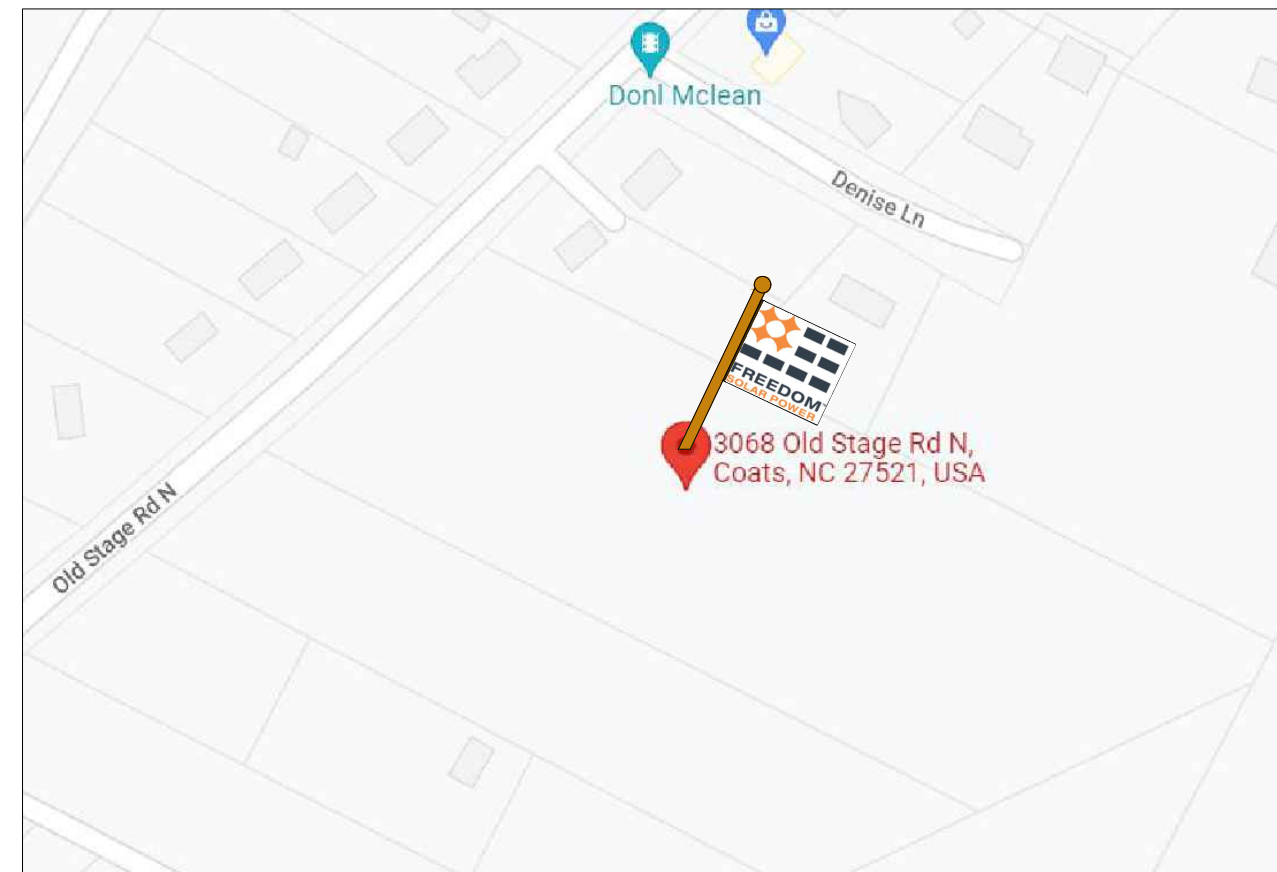

VICINITY MAP

DESIGN BY
FREEDOM SOLAR LLC

REVISIONS		
DESCRIPTION	DATE	REV
DESIGN PACKET	06/06/2022	A

CONTRACTOR

FREEDOM[™]
SOLAR POWER

FREEDOM SOLAR LLC
4801 FREIDRICH LN, STE 100
AUSTIN, TX 78744
TECL # 28621
TBPE FIRM # F-17690

PROJECT NAME

QUIGLEY, DALE
3068 OLD STAGE ROAD NORTH
COATS, NORTH CAROLIN, 27521
(919) 280-8815

SHEET NAME

COVER

SHEET SIZE

ANSI B
11" x 17"

SHEET NUMBER

PV-0

LEAD ID: 102543

CONSTRUCTION SUMMARY

- (13) (SUNPOWER SPR-M425-H-AC) SOLAR MODULES, 5.53 kW DC STC
MODULE DIMENSIONS = 40.6" X 73.7" X 1.57"
- (13) SUNPOWER SPR-M425-H-AC [240V] PV INVERTERS
COMBINED INVERTER OUTPUT = 4.99 kW AC.
- (108) (10 X 10.75') LINEAR FEET SUNPOWER INVISIMOUNT
- (36) SPCR-CH ROOF ATTACHMENTS
- (01) SUNPOWER MONITORING

SITE DETAILS

ROOF TYPE: ASPHALT SHINGLE
ARRAY #1 - TILT = 33°, AZIMUTH = 112°

INSTALLATION DIFFICULTY = 8 => NORMAL

MAIN HOUSE

FIRE CODE SETBACK
PER 2015 IFC 605.11.3

DUKE ENERGY REVENUE METER
#325 129 420
GROUNDING ELECTRODE METER/MAIN COMBO PANEL
SOLAR LOAD CENTER
MONITORING
PV AC DISCONNECT
-VISIBLE BREAK
-LOCKABLE
-LABELED
(OUTSIDE HOUSE WALL)

PV ARRAY #1
(13) MODULES

DETACHED STRUCTURE



DESIGN BY
FREEDOM SOLAR LLC

REVISIONS

DESCRIPTION	DATE	REV
DESIGN PACKET	06/06/2022	A

CONTRACTOR

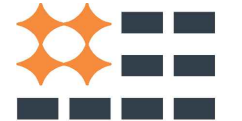

FREEDOM SOLAR POWER
FREEDOM SOLAR LLC
4801 FREIDRICH LN, STE 100
AUSTIN, TX 78744
TECL # 28621
TBPE FIRM # F-17690

PROJECT NAME

QUIGLEY, DALE
3068 OLD STAGE ROAD NORTH
COATS, NORTH CAROLIN, 27521
(919) 280-8815

SHEET NAME

SITE MAP & PV LAYOUT

SHEET SIZE

ANSI B
11" x 17"

SHEET NUMBER

PV-1

CONSTRUCTION NOTES

- 1.) ALL EQUIPMENT SHALL BE INSTALLED IN ACCORDANCE WITH THE MANUFACTURER'S INSTALLATION INSTRUCTIONS.
- 2.) ALL OUTDOOR EQUIPMENT SHALL BE RAIN-TIGHT WITH MINIMUM NEMA 3R RATING.
- 3.) ALL LOCATIONS ARE APPROXIMATE AND REQUIRE FIELD VERIFICATION.

WEIGHT OF PV ARRAY < 3 PSF
 LAYER OF ASPHALT SHINGLES = 1
 ROOFING MATERIAL = ASPHALT SHINGLES
 WIND SPEED = 118 MPH
 THEREFORE NC REGISTERED DESIGN
 PROFESSIONAL SEAL IS NOT REQUIRED.

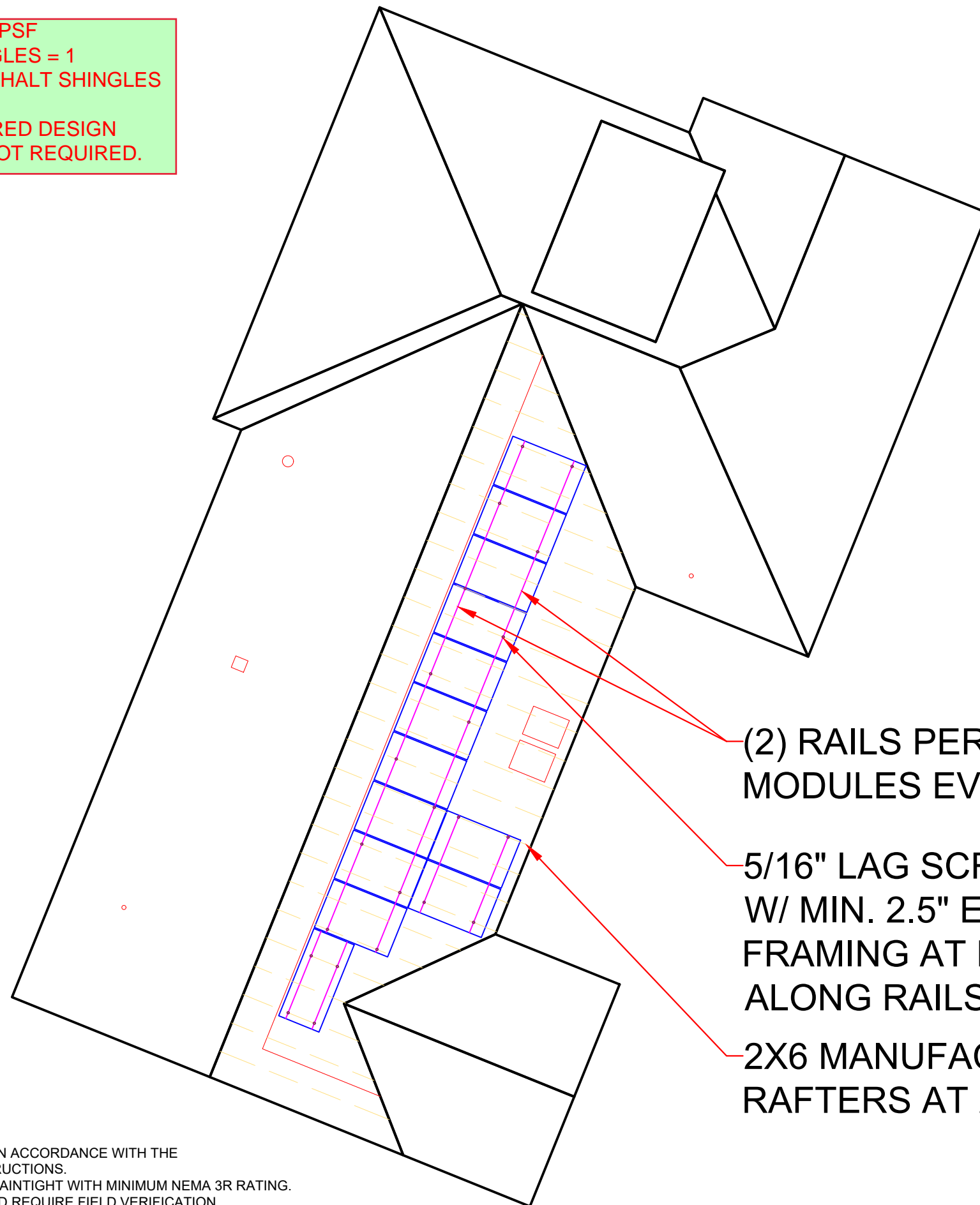

(2) RAILS PER ROW OF
 MODULES EVENLY SPACED

5/16" LAG SCREW
 W/ MIN. 2.5" EMBEDMENT INTO
 FRAMING AT MAX 72" O.C.
 ALONG RAILS

2X6 MANUFACTURED
 RAFTERS AT 24" O.C. TYP.

CONSTRUCTION NOTES

- 1.) ALL EQUIPMENT SHALL BE INSTALLED IN ACCORDANCE WITH THE MANUFACTURER'S INSTALLATION INSTRUCTIONS.
- 2.) ALL OUTDOOR EQUIPMENT SHALL BE RAIN-TIGHT WITH MINIMUM NEMA 3R RATING.
- 3.) ALL LOCATIONS ARE APPROXIMATE AND REQUIRE FIELD VERIFICATION.

DESIGN BY
 FREEDOM SOLAR LLC

REVISIONS		
DESCRIPTION	DATE	REV
DESIGN PACKET	06/06/2022	A

CONTRACTOR

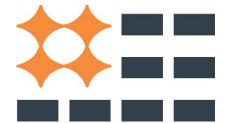

**FREEDOM[™]
 SOLAR POWER**

FREEDOM SOLAR LLC
 4801 FREIDRICH LN, STE 100
 AUSTIN, TX 78744
 TECL # 28621
 TBPE FIRM # F-17690

PROJECT NAME

QUIGLEY, DALE
 3068 OLD STAGE ROAD NORTH
 COATS, NORTH CAROLIN, 27521
 (919) 280-8815

SHEET NAME

RACKING PLAN

SHEET SIZE

ANSI B
 11" x 17"

SHEET NUMBER

PV-1A

DESIGN BY
FREEDOM SOLAR LLC

REVISIONS

DESCRIPTION	DATE	REV
DESIGN PACKET	06/06/2022	A

CONTRACTOR



**FREEDOM[™]
SOLAR POWER**
FREEDOM SOLAR LLC
4801 FREIDRICH LN, STE 100
AUSTIN, TX 78744
TECL # 28621
TBPE FIRM # F-17690

PROJECT NAME

QUIGLEY, DALE
3068 OLD STAGE ROAD NORTH
COATS, NORTH CAROLIN, 27521
(919) 280-8815

SHEET NAME

STRING MAP
&
MONITORING
LAYOUT

SHEET SIZE

ANSI B
11" x 17"

SHEET NUMBER

PV-2

SUNPOWER SUPERVISOR S/N _____

SOLAR ARRAY - 5.53 kW DC STC (13) (SUNPOWER SPR-M425-H-AC) MODULES

JUNCTION BOX:
TRANSITION FROM DG CABLE
TO AWG #10 THWN-2
NEMA 3R, UL LISTED

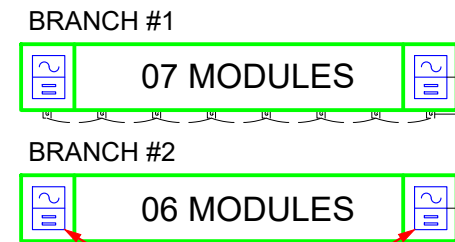

(13) (SUNPOWER SPR-M425-H-AC [240V])
INVERTERS 240VAC, 1.60A MAX
CEC WEIGHTED EFFICIENCY 97.0%
NEMA 4R, UL LISTED, INTERNAL GFDI

(4) AWG #10 THWN-2
(1) AWG #6 THWN-2 GND
IN 3/4" CONDUIT

NEW SOLAR LOAD CENTER
240VAC, 125A
NEMA 3R, UL LISTED
(3) 2P-20A BREAKERS

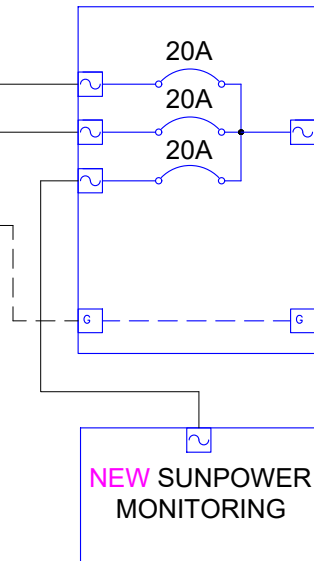

NEW PV AC DISCONNECT
240VAC, 60A
NON -FUSIBLE,
NEMA 3R, UL LISTED,
VISIBLE, LOCKABLE, LABELED

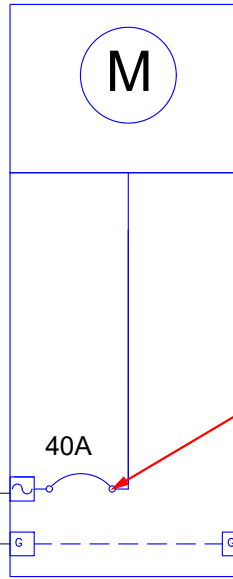
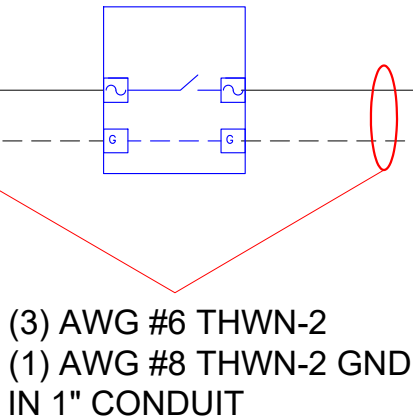

DUKE ENERGY REVENUE METER
#325 129 420
1-PHASE, 240V

METER/MAIN COMBO PANEL
EATON, 1P3W
240V, 200A BUS

POINT OF INTERCONNECTION
(1) 2P-40A CIRCUIT BREAKER
INSTALLED AT OPPOSITE END OF
BUS FROM MAIN DISCONNECT

EXISTING GROUNDING
ELECTRODE SYSTEM

ELECTRICAL NOTES

- ALL EQUIPMENT TO BE LISTED BY UL OR OTHER NRTL, AND LABELED FOR ITS APPLICATION.
- ALL CONDUCTORS SHALL BE COPPER, RATED FOR 600 V AND 90°C WET ENVIRONMENT UNLESS OTHERWISE NOTED.
- WIRING, CONDUIT, AND RACEWAYS MOUNTED ON ROOFTOPS SHALL BE ROUTED DIRECTLY TO, AND LOCATED AS CLOSE AS POSSIBLE TO THE NEAREST RIDGE, HIP, OR VALLEY.
- WORKING CLEARANCES AROUND ALL NEW AND EXISTING ELECTRICAL EQUIPMENT SHALL COMPLY WITH NEC 110.26.
- DRAWINGS INDICATE THE GENERAL ARRANGEMENT OF SYSTEMS. CONTRACTOR SHALL FURNISH ALL NECESSARY OUTLETS, SUPPORTS, FITTINGS AND ACCESSORIES TO FULFILL APPLICABLE CODES AND STANDARDS.
- WHERE SIZES OF JUNCTION BOXES, RACEWAYS, AND CONDUITS ARE NOT SPECIFIED, THE CONTRACTOR SHALL SIZE THEM ACCORDINGLY.
- ALL WIRE TERMINATIONS SHALL BE APPROPRIATELY LABELED AND READILY VISIBLE.
- MAXIMUM MOUNTING HEIGHT FROM GRADE TO CENTER OF METER SOCKET SHALL BE 72" FOR RESIDENTIAL SINGLE PHASE METER SOCKETS 0-320 AMPS. MINIMUM MOUNTING HEIGHT IS 30" FROM FOR AUSTIN ENERGY, AND 48" FOR ALL OTHER JURISDICTIONS
- MINIMUM HORIZONTAL CLEARANCE FROM GAS REGULATOR TO ANY ELECTRICAL ENCLOSURE IS 36", EXCEPT AUSTIN ENERGY WHICH REQUIRES 48" CLEARANCE FROM GAS TO METER SOCKET
- PV DISCONNECT SHALL BE VISIBLE, LOCKABLE AND LABELED AND THE DOOR CANNOT BE OPENED WHEN HANDLE IS IN ON POSITION
- BY DEFAULT THE MONITORING DEVICE IS SHOWN CONNECTED TO A 20-AMP BREAKER IN THE SOLAR LOAD CENTER. ALTERNATIVELY, THE MONITORING DEVICE MAY BE CONNECTED TO A 20-AMP BREAKER AT THE MAIN DISTRIBUTION PANEL.
- ALL EQUIPMENT TERMINATIONS SHALL BE RATED FOR 75 DEGREES OR GREATER
- ALL CT WIRES SHALL BE CONSIDERED CLASS 1 PER NEC ARTICLE 725, AND BE MARKED AS RATED FOR 600V. PER 725.48(A) CLASS 1 CIRCUITS SHALL BE PERMITTED TO OCCUPY THE SAME RACEWAY AS OTHER CIRCUITS PROVIDED ALL CONDUCTORS ARE INSULATED FOR THE MAXIMUM VOLTAGE OF ANY CONDUCTOR IN THE RACEWAY.
- AWG #10 COPPER CONDUCTORS ARE SPECIFIED AS THE DEFAULT WIRE REQUIRE FROM THE PV ARRAY TO THE SOLAR LOAD CENTER, HOWEVER, AWG #12 COPPER CONDUCTORS MAY BE UTILIZED IF BOTH OF THE FOLLOWING CONDITIONS ARE MET: THE LENGTH OF THE CONDUCTOR IS LESS THAN 75 FT AND THERE ARE LESS THAN 8 CURRENT-CARRYING CONDUCTORS WITHIN THE RACEWAY.

CALCULATIONS FOR CURRENT CARRYING CONDUCTORS	CALCULATIONS FOR OVERCURRENT DEVICES
<p>INVERTER OUTPUT WIRE AMPACITY CALCULATION [NEC 690.8(A)(3)]: 1.60A PER INVERTER (SUNPOWER SPR-M425-H-AC [240V]) MAXIMUM INVERTER BRANCH CURRENT = (10)(1.60A) = 16.0A CONTINUOUS USE: #10 WIRE 75°C DERATED AMPACITY = (0.80)(35.0A) = 28.0A 28.0A > 16.0A</p> <p>CONDITIONS OF USE: #10 WIRE 90°C DERATED AMPACITY = (0.91)(0.80)(40.0A) = 29.1A 29.1A > 16.0A</p> <p>SOLAR LOAD CENTER OUTPUT WIRE AMPACITY CALCULATION [NEC 690.8(A)(3)]: 1.60A PER INVERTER (SUNPOWER SPR-M425-H-AC [240V]) COMBINED CURRENT = (13)(1.60A) = 20.8A CONTINUOUS USE: #6 WIRE 75°C DERATED AMPACITY = (0.80)(65A) = 52.0A 52.0A > 20.8A</p> <p>CONDITIONS OF USE: #6 WIRE 90°C DERATED AMPACITY = (0.91)(75A) = 68.3A 68.3A > 20.8A</p>	<p>INVERTER BRANCH AC CURRENT CALCULATION [NEC 690.8(A)(3)]: 1.60A PER INVERTER (SUNPOWER SPR-M425-H-AC [240V]) MAXIMUM BRANCH INVERTER CURRENT = (10)(1.60A) = 16.0A MINIMUM OCPD = (16.0A)(1.25) = 20.0A USE 2P-20A BREAKERS IN SOLAR LOAD CENTER FOR INVERTER BRANCH OCPD</p> <p>SYSTEM AC CURRENT CALCULATION [NEC 690.8(A)(3)]: 1.60A PER INVERTER (SUNPOWER SPR-M425-H-AC [240V]) COMBINED CURRENT = (13)(1.60A) = 20.8A MINIMUM OCPD = (20.8A)(1.25) = 26.0A USE 2P-40A BREAKER IN MDP FOR SYSTEM OCPD</p>

DESIGN BY
FREEDOM SOLAR LLC

REVISIONS		
DESCRIPTION	DATE	REV
DESIGN PACKET	06/06/2022	A

CONTRACTOR

**FREEDOM™
SOLAR POWER**

FREEDOM SOLAR LLC
4801 FREIDRICH LN, STE 100
AUSTIN, TX 78744
TECL # 28621
TBPE FIRM # F-17690

PROJECT NAME

QUIGLEY, DALE

3068 OLD STAGE ROAD NORTH

COATS, NORTH CAROLIN, 27521

(919) 280-8815

SHEET NAME

**ELECTRICAL
DIAGRAM**

SHEET SIZE

**ANSI B
11" x 17"**

SHEET NUMBER

PV-3

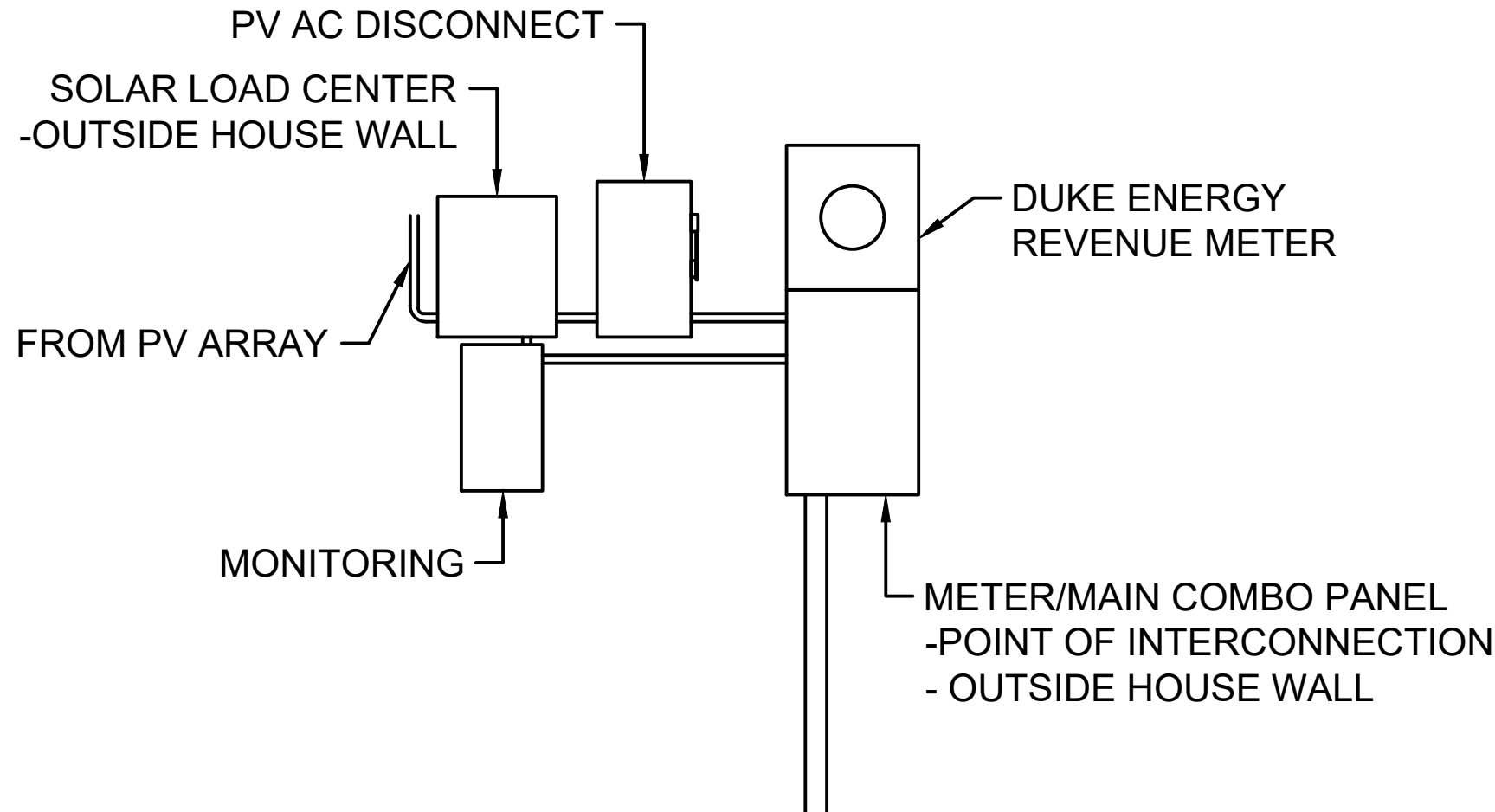

DESIGN BY
FREEDOM SOLAR LLC

REVISIONS		
DESCRIPTION	DATE	REV
DESIGN PACKET	06/06/2022	A

CONTRACTOR

FREEDOM
SOLAR POWER

FREEDOM SOLAR LLC
4801 FREIDRICH LN, STE 100
AUSTIN, TX 78744
TECL # 28621
TBPE FIRM # F-17690

PROJECT NAME

QUIGLEY, DALE

3068 OLD STAGE ROAD NORTH

COATS, NORTH CAROLIN, 27521

(919) 280-8815

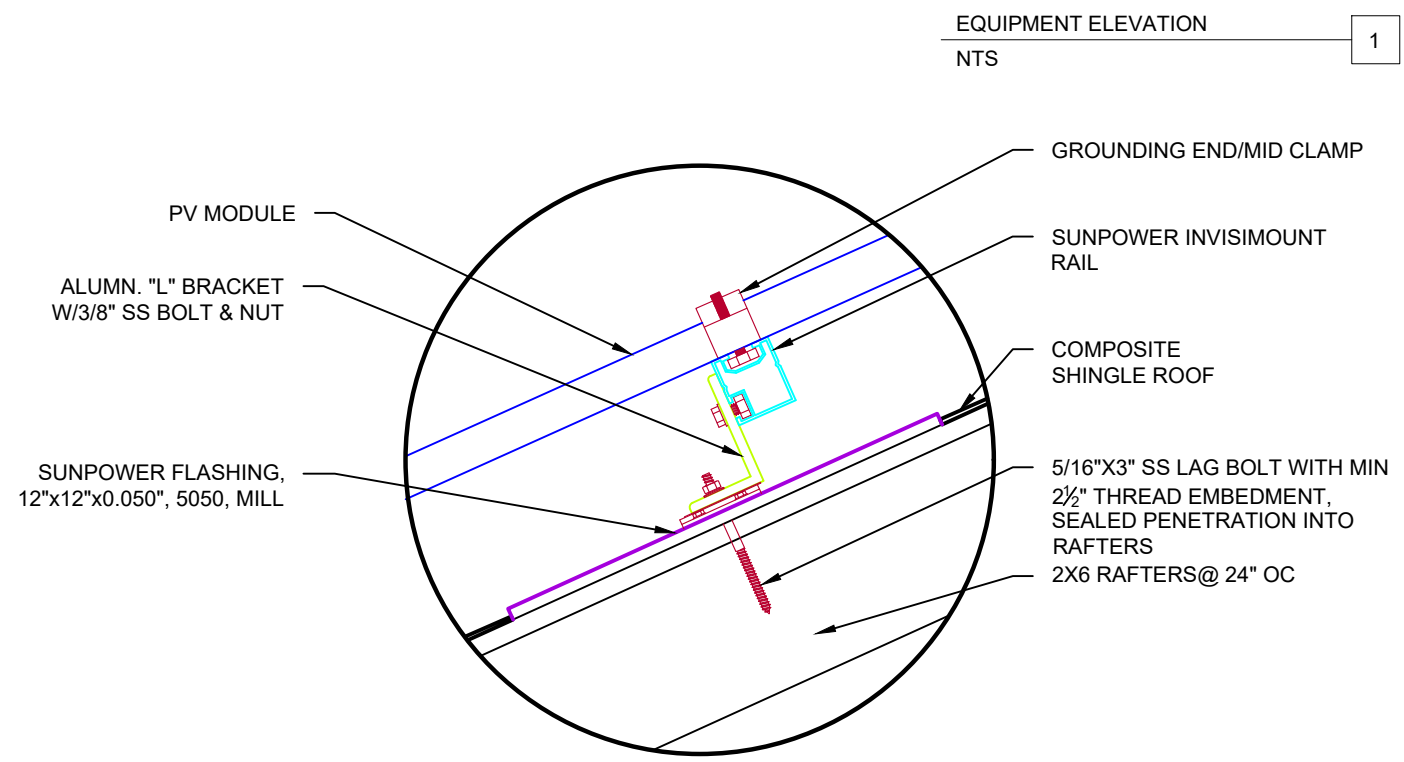
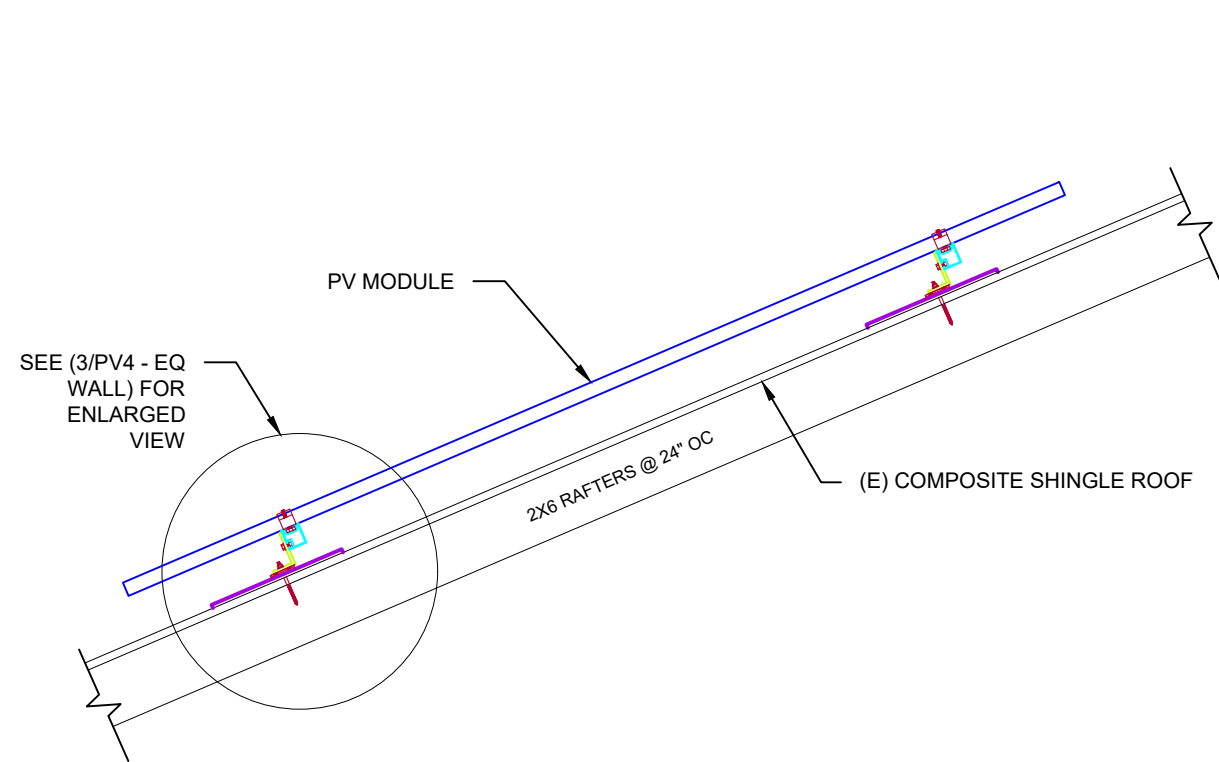

MOUNTING METHOD

NTS

2

MOUNTING DETAIL

NTS

3

SHEET NAME

EQ.WALL &
MOUNTING DETAIL

SHEET SIZE

ANSI B
11" x 17"

SHEET NUMBER

PV-4

NOTE: NOT ALL LABELS MAY BE APPLICABLE

WARNING
ELECTRIC SHOCK HAZARD.
DO NOT TOUCH TERMINALS.
TERMINALS ON BOTH THE
LINE AND LOAD SIDES MAY BE
ENERGIZED IN THE OPEN
POSITION.

REQ'D BY: NEC 690.13 (B)
APPLY TO:
PV DISCONNECT

A

WARNING
-SOLAR LOAD CENTER-
THIS EQUIPMENT FED BY
MULTIPLE SOURCES, TOTAL RATING
OF ALL OVERCURRENT DEVICES,
EXCLUDING MAIN SUPPLY
OVERCURRENT DEVICES, SHALL NOT
EXCEED AMPACITY OF BUSBAR.

REQ'D BY: 705.12(B)(3)(3)
APPLY TO:
SOLAR LOAD CENTER

B

PV SYSTEM DISCONNECT

OPERATING CURRENT: 20.8 A
OPERATING VOLTAGE: 240 VAC

REQ'D BY: NEC 690.13(B); 690.54
APPLY TO:
PV DISCONNECT

C

WARNING
POWER SOURCE OUTPUT
CONNECTION. DO NOT
RELOCATE THIS
OVERCURRENT DEVICE

REQ'D BY: NEC 705.12(B)(3)(2)
APPLY TO:
PV SYSTEM BREAKER

D

WARNING
DUAL POWER SUPPLY
SOURCES: UTILITY GRID AND
PV SOLAR ELECTRIC SYSTEM

REQ'D BY: NEC 705.12(C)
MAIN SERVICE PANEL

E

**WARNING: PHOTOVOLTAIC
POWER SOURCE**

REQ' BY: NEC 690.31(D)(2)*
APPLY TO:
CONDUIT EVERY 10 FT
(*ONLY REQUIRED FOR RACEWAYS
WITH PV **DC** CIRCUITS)

F

**SOLAR PV SYSTEM EQUIPPED
WITH RAPID SHUTDOWN**

TURN RAPID SHUTDOWN
SWITCH TO THE "OFF"
POSITION TO SHUT DOWN
PV SYSTEM AND REDUCE
SHOCK HAZARD IN THE
ARRAY.

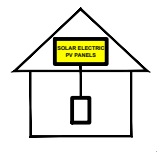

REQ'D BY: FREEDOM SOLAR
APPLY TO:
MAIN DISTRIBUTION PANEL

G

**CAUTION:
MULTIPLE SOURCES OF POWER**

POWER TO THIS BUILDING IS ALSO SUPPLIED FROM THE
FOLLOWING SOURCES WITH DISCONNECTS AS SHOWN:

UTILITY SUPPLY & CUSTOMER
SERVICE PANEL

PV AC DISCONNECT

RAPID SHUTDOWN SWITCH



FRONT

REQ'D BY: 705.10*
APPLY TO:
MAIN DISTRIBUTION PANEL
(*ONLY REQUIRED IF PV SYSTEM
DISCONNECT IS NOT GROUPED
WITH MAIN SERVICE DISCONNECT)
**SEE SHEET PV-6 FOR SITE
SPECIFIC LABEL**

H

DESIGN BY
FREEDOM SOLAR LLC

REVISIONS		
DESCRIPTION	DATE	REV
DESIGN PACKET	06/06/2022	A

CONTRACTOR



**FREEDOMTM
SOLAR POWER**

FREEDOM SOLAR LLC
4801 FREDRICH LN, STE 100
AUSTIN, TX 78744
TECL # 28621
TBPE FIRM # F-17690

PROJECT NAME

QUIGLEY, DALE
3068 OLD STAGE ROAD NORTH
COATS, NORTH CAROLIN, 27521
(919) 280-8815

SHEET NAME

SYSTEM
LABELING
DETAIL

SHEET SIZE

ANSI B
11" x 17"

SHEET NUMBER

PV-5

CAUTION:
MULTIPLE SOURCES OF POWER
 LOCATION OF EACH POWER SOURCE
 DISCONNECTING MEANS SHOWN BELOW

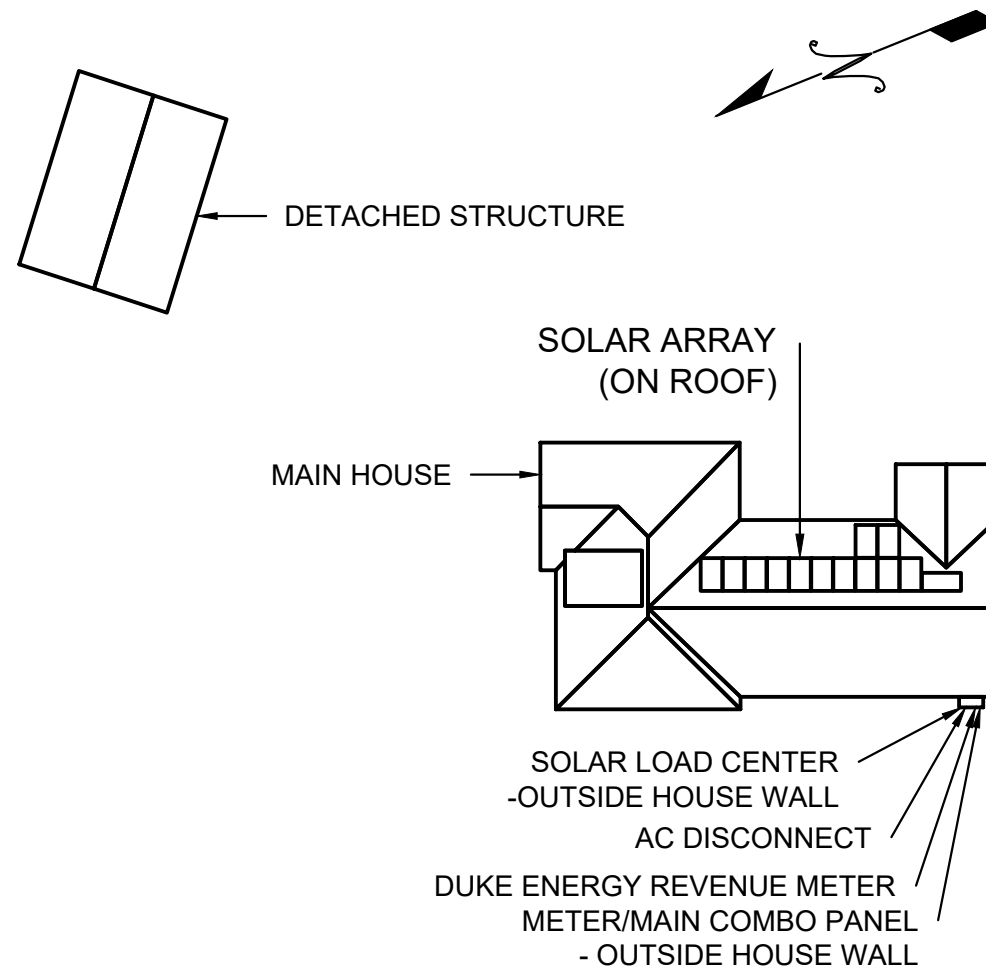

QUESTIONS, CALL:
 800-504-2337
www.freedomsolarpower.com

FREEDOM
SOLAR POWER
 3068 OLD STAGE ROAD NORTH
 PROJECT ID: 102543

DESIGN BY
 FREEDOM SOLAR LLC

REVISIONS		
DESCRIPTION	DATE	REV
DESIGN PACKET	06/06/2022	A

CONTRACTOR



FREEDOM
SOLAR POWER

FREEDOM SOLAR LLC
 4801 FREIDRICH LN, STE 100
 AUSTIN, TX 78744
 TECL # 28621
 TBPE FIRM # F-17690

PROJECT NAME

QUIGLEY, DALE
 3068 OLD STAGE ROAD NORTH
 COATS, NORTH CAROLIN, 27521
 (919) 280-8815

SHEET NAME

SITE
 DIRECTORY
 PLACARD

SHEET SIZE

ANSI B
 11" x 17"

SHEET NUMBER

PV-6

USE THE SAFETY SYMBOL KEY TO DRAW IN THE CONTROLLED ACCESS ZONE (CAZ), LADDER PLACEMENT, METER LOCATION, FALL PROTECTION ANCHOR POINT, AND ANY OTHER HAZARD.

HARD HAT IS REQUIRED AT ALL TIMES IN CAZ

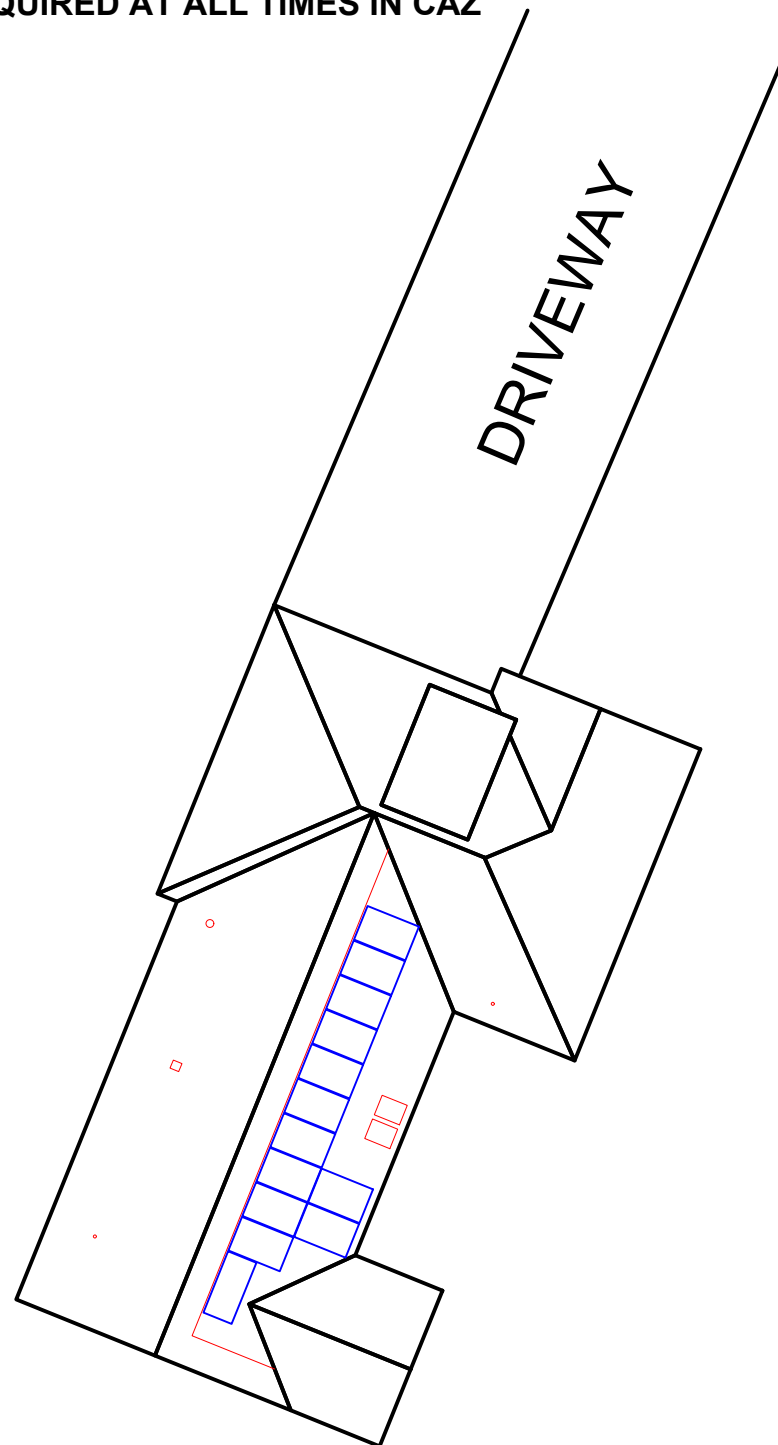

SAFETY SYMBOL KEY

- CAZ
- L** LADDER
- M** METER
- ==== POWER LINES
- R** RESTRAINT ANCHOR
- A** ARREST ANCHOR



DESIGN BY
FREEDOM SOLAR LLC

REVISIONS		
DESCRIPTION	DATE	REV
DESIGN PACKET	06/06/2022	A

CONTRACTOR

**FREEDOM[™]
SOLAR POWER**

FREEDOM SOLAR LLC
4801 FREIDRICH LN, STE 100
AUSTIN, TX 78744
TECL # 28621
TBPE FIRM # F-17690

PROJECT NAME

QUIGLEY, DALE
3068 OLD STAGE ROAD NORTH
COATS, NORTH CAROLIN, 27521
(919) 280-8815

SHEET NAME

SAFETY PLAN

SHEET SIZE

ANSI B
11" x 17"

SHEET NUMBER

PV-7

CONDUCT SAFETY MEETING WITH ALL CREW MEMBERS ON SITE AT THE BEGINNING OF EACH JOB. USE SIGN IN SHEET BELOW.

1. _____
2. _____
3. _____
4. _____
5. _____

GUEST SIGN IN

1. _____
2. _____
3. _____

COMPETENT PERSON: _____ JOB START DATE: _____



SUNPOWER®

M-Series: M440 | M435 | M430 | M425 | M420 SunPower® Residential AC Module

420-440W Residential AC Module

SunPower® Maxeon® Technology

Built specifically for use with the SunPower Equinox® system, the only fully integrated solar solution designed, engineered, and warranted by one company.



Highest Power AC Density Available.

The patented, solid-copper foundation Maxeon Gen 6 cell is over 5% larger than prior generations, delivering the highest efficiency AC solar panel available.¹

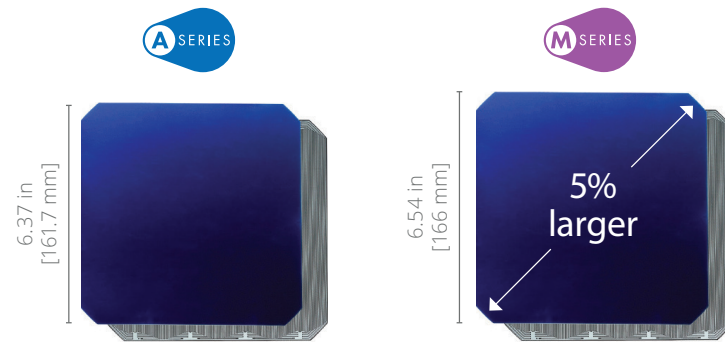

Highest Lifetime Energy and Savings

Designed to deliver 60% more energy over 25 years in real-world conditions like partial shade and high temperatures.²

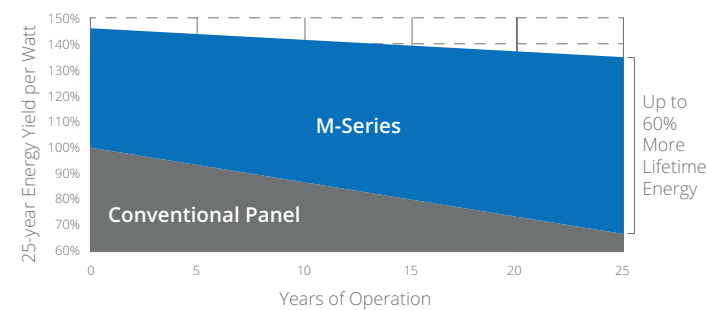

Best Reliability, Best Warranty

With more than 42.6 million and 15 GW modules deployed around the world, SunPower technology is proven to last. That's why we stand behind our module and microinverter with the industry's best 25-year Combined Power and Product Warranty.

Part of the SunPower Equinox® Solar System

- Compatible with mySunPower™ monitoring
- Seamless aesthetics

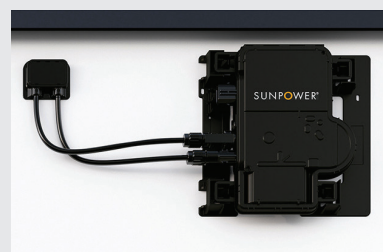

Factory-integrated Microinverter

- Highest-power integrated AC module in solar
- Engineered and calibrated by SunPower for SunPower AC modules

AC Electrical Data		
	@240 VAC	@208 VAC
Inverter Model: Type H (Enphase IQ7HS)		
Max. Continuous Output Power (VA)	384	369
Nom. (L-L) Voltage/Range ³ (V)	240 / 211–264	208 / 183–229
Max. Continuous Output Current (Arms)	1.60	1.77
Max. Units per 20 A (L-L) Branch Circuit ⁴	10	9
CEC Weighted Efficiency	97.0%	96.5%
Nom. Frequency		60 Hz
Extended Frequency Range		47–68 Hz
AC Short Circuit Fault Current Over 3 Cycles		4.82 A rms
Overtoltage Class AC Port		III
AC Port Backfeed Current		18 mA
Power Factor Setting		1.0
Power Factor (adjustable)		0.85 (inductive) / 0.85 (capacitive)

DC Power Data					
	SPR-M440-H-AC	SPR-M435-H-AC	SPR-M430-H-AC	SPR-M425-H-AC	SPR-M420-H-AC
Nom. Power ⁶ (P _{nom}) W	440	435	430	425	420
Power Tolerance	+5/-0%				
Module Efficiency	22.8%	22.5%	22.3%	22.0%	21.7%
Temp. Coef. (Power)	-0.29% / °C				
Shade Tolerance	Integrated module-level max. power point tracking				

Tested Operating Conditions	
Operating Temp.	-40° F to +185°F (-40°C to +85°C)
Max. Ambient Temp.	122°F (50°C)
Max. Test Load ⁸	Wind: 125 psf, 6000 Pa, 611 kg/m ² back Snow: 187 psf, 9000 Pa, 917 kg/m ² front
Max. Design Load	Wind: 75 psf, 3600 Pa, 367 kg/m ² back Snow: 125 psf, 6000 Pa, 611 kg/m ² front
Impact Resistance	1 inch (25 mm) diameter hail at 52 mph (23 m/s)

Mechanical Data	
Solar Cells	66 Maxeon Gen 6
Front Glass	High-transmission tempered glass with anti-reflective coating
Environmental Rating	Outdoor rated
Frame	Class 1 black anodized (highest AAMA rating)
Weight	48 lb (21.8 kg)
Recommended Max. Module Spacing	1.3 in. (33 mm)

1 Based on datasheet review of websites of top 20 manufacturers per Wood Mackenzie US PV Leaderboard Q3 2021.
 2 Maxeon 435 W, 22.5% efficient, compared to a Conventional Panel on same-sized arrays (260 W, 16% efficient, approx. 1.6 m²), 7.9% more energy per watt (based on PVsyst pan files for avg. US climate), 0.5%/yr slower degradation rate (Jordan, et. al. "Robust PV Degradation Methodology and Application,"PVC 2018).
 3 Voltage range can be extended beyond nominal if required by the utility.
 4 Limits may vary. Refer to local requirements to define the number of microinverters per branch in your area.
 5 Factory set to IEEE 1547a-2014 default settings. CA Rule 21 default settings profile set during commissioning.
 6 Standard Test Conditions (1000 W/m² irradiance, AM 1.5, 25°C). All DC voltage is fully contained within the module.
 7 UL Listed as PVRSSE and conforms with NEC 2014 and NEC 2017 690.12; and C22.1-2015 Rule 64-218 Rapid Shutdown of PV Systems, for AC and DC conductors; when installed according to manufacturer's instructions.
 8 Please read the safety and installation instructions for more information regarding load ratings and mounting configurations.

See www.sunpower.com/company for more reference information. Specifications included in this datasheet are subject to change without notice.
 ©2022 SunPower Corporation. All rights reserved. SUNPOWER, the SUNPOWER logo, EQUINOX and MYSUNPOWER are trademarks or registered trademarks of SunPower Corporation in the U.S. MAXEON is a registered trademark of Maxeon Solar Technologies, Ltd. For more information visit www.maxeon.com/legal.

Warranties, Certifications, and Compliance	
Warranties	<ul style="list-style-type: none"> • 25-year limited power warranty • 25-year limited product warranty
Certifications and Compliance	<ul style="list-style-type: none"> • UL 1741 / IEEE-1547 • UL 1741 AC Module (Type 2 fire rated) • UL 61730 • UL 62109-1 / IEC 62109-2 • FCC Part 15 Class B • ICES-0003 Class B • CAN/CSA-C22.2 NO. 107.1-01 • CA Rule 21 (UL 1741 SA)⁵ (includes Volt/Var and Reactive Power Priority) • UL Listed PV Rapid Shutdown Equipment⁷ <p>Enables installation in accordance with:</p> <ul style="list-style-type: none"> • NEC 690.6 (AC module) • NEC 690.12 Rapid Shutdown (inside and outside the array) • NEC 690.15 AC Connectors, 690.33(A)-(E)(1) <p>When used with AC module Q Cables and accessories (UL 6703 and UL 2238)⁷:</p> <ul style="list-style-type: none"> • Rated for load break disconnect
PID Test	1000 V: IEC 62804

Packaging Configuration	
Modules per pallet	25
Packaging box dimensions	75.4 × 42.2 × 48.0 in. (1915 × 1072 × 1220 mm)
Pallet gross weight	1300.7 lb (590 kg)
Pallets per container	32
Net weight per container	41,623 lb (18,880 kg)

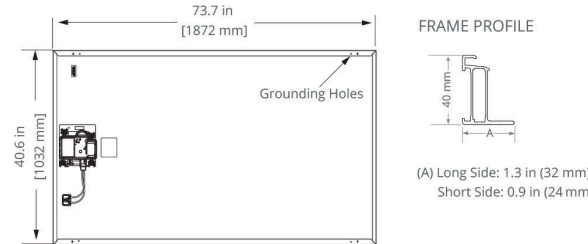

Please read the safety and installation instructions for details.

AC MODULE GRID SUPPORT UTILITY INTERACTIVE PV RAPID SHUTDOWN EQUIPMENT E478330 LISTED
 Module Fire Performance: Type 2

539973 RevB
 January 2022



SunPower® EnergyLink™ | Residential and Commercial PVS6

Improve Support, Reduce Maintenance Costs

An intuitive monitoring website enables you to:

- See a visual map of customer sites
- Remotely manage hundreds of sites
- Receive elective system reports
- Locate system issues and remotely diagnose
- Diagnose issues online
- Drill down for the status of individual devices

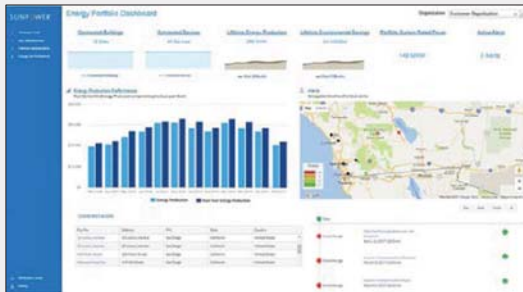

Add Value for Customers

With the SunPower Monitoring System customers can:

- See what their solar system produces each day, month, or year
- Optimize their solar investment and save on energy expenses
- See their energy use and estimated bill savings
- See their solar system's performance using the SunPower monitoring website or mobile app



SunPower EnergyLink—Plug-and-Play Installation

This complete solution for residential and commercial monitoring and control includes the SunPower® PV Supervisor 6 (PVS6) which improves the installation process, overall system reliability, and customer experience.

- Compact footprint for improved aesthetics
- Robust cloud connectivity and comprehensive local connectivity
- Flexible configuration of devices during installation
- Consumption metering
- Revenue-grade production metering (pending)
- Web-based commissioning
- Remote diagnostics of PVS6 and inverters
- Durable UL Type 3R enclosure reduces maintenance costs
- Easy integration with SunPower eBOS



Robust Cloud Connectivity

Multiple options to maintain optimal connectivity:

- Hardwired Ethernet
- Wi-Fi
- Cellular backup



SunPower® EnergyLink™ | Residential and Commercial PVS6

SunPower Monitoring Websites

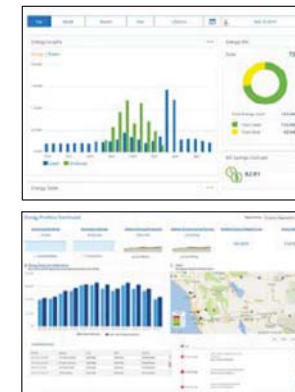

PVS6



SunPower AC Modules

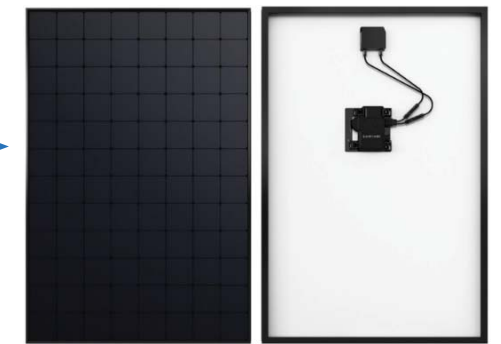

Multiple communication options include Ethernet, Wi-Fi, and cellular.

Site Requirements	
Number of SunPower AC modules supported per PVS6	85
Internet access	High-speed internet access via accessible router or switch
Power	<ul style="list-style-type: none"> • 100–240 VAC (L–N), 50 or 60 Hz • 208 VAC (L–L in 3-phase), 60 Hz

Operating Conditions	
Temperature	–22°F to +140°F (–30°C to +60°C)
Humidity (maximum)	95%, non-condensing

Mechanical	
Weight	5.5 lbs (2.5 kg)
Dimensions	11.8 × 8.0 × 4.2 in. (30.5 × 20.5 × 10.8 cm)
Enclosure rating	UL50E Type 3R

Communication	
RS-485	Inverters and meters
Integrated Metering	<ul style="list-style-type: none"> • One channel of revenue-grade production metering • Two channels of consumption metering
Ethernet	1 LAN (or optional WAN) port
PLC	PLC for SunPower AC modules
Wi-Fi	802.11b/g/n 2.4 GHz and 5 GHz
Cellular	LTE Cat-M1/3G UMTS
ZigBee	IEEE 802.15.4 MAC, 2.4GHz ISM band
Data Storage	60 days
Upgrades	Automatic firmware upgrades

Web and Mobile Device Support	
Customer site	monitor.us.sunpower.com
Partner site	pvsmgmt.us.sunpower.com
Browsers	Firefox, Safari, and Chrome
Mobile devices	iPhone®, iPad®, and Android™
Customer app	<ol style="list-style-type: none"> 1. Create account online at: monitor.us.sunpower.com. 2. On a mobile device, download the SunPower Monitoring app from Apple App Store™ or Google Play™ store. 3. Sign in using account email and password.

Warranty and Certifications	
Warranty	10-year Limited Warranty
Certifications	UL, cUL, CE, UL 61010-1 and -2, FCC Part 15 (Class B)



© 2019 SunPower Corporation. All rights reserved. SUNPOWER, SUNPOWER logo, and ENERGYLINK are trademarks or registered trademarks of SunPower Corporation. iPhone and iPad are registered trademarks of Apple Inc. Android and Google Play are trademarks of Google Inc. All other trademarks are the property of their respective owners. Specifications included in this datasheet are subject to change without notice.

530536 RevC





SunPower® InvisiMount™ | Residential Mounting System

Simple and Fast Installation

- Integrated module-to-rail grounding
- Pre-assembled mid and end clamps
- Levitating mid clamp for easy placement
- Mid clamp width facilitates consistent, even module spacing
- UL 2703 Listed integrated grounding

Flexible Design

- Addresses nearly all sloped residential roofs
- Design in landscape and portrait with up to 8' rail span
- Pre-drilled rails and rail splice
- Rails enable easy obstacle management

Customer-Preferred Aesthetics

- #1 module and #1 mounting aesthetics
- Best-in-class system aesthetics
- Premium, low-profile design
- Black anodized components
- Hidden mid clamps and capped, flush end clamps

Part of Superior System

- Built for use with SunPower DC and AC modules
- Best-in-class system reliability and aesthetics
- Optional rooftop transition flashing, rail-mounted J-box, and wire management rail clips
- Combine with SunPower modules and SunPower EnergyLink® monitoring app



Elegant Simplicity

SunPower® InvisiMount™ is a SunPower-designed rail-based mounting system. The InvisiMount system addresses residential sloped roofs and combines faster installation time, design flexibility, and superior aesthetics. The InvisiMount product was specifically envisioned and engineered to pair with SunPower modules. The resulting system-level approach amplifies the aesthetic and installation benefits—for homeowners and for installers.

sunpower.com



SunPower® InvisiMount™ | Residential Mounting System

InvisiMount Components



InvisiMount Component Details		
Mid clamp	Black oxide stainless steel 300 series	63 g (2.2 oz)
End clamp	Black anodized aluminum 6000 series	110 g (3.88 oz)
Rail	Black anodized aluminum 6000 series	830 g/m (9 oz/ft)
Rail splice	Aluminum alloy 6000 series	830 g/m (9 oz/ft)
Rail bolt	M10-1.5 x 25 mm; custom T-head SS304	18 g (0.63 oz)
Rail nut	M10-1.5; DIN 6923 SS304	nominal
Ground lug assembly	SS304; A2-70 bolt; tin-plated copper lug	106.5 g (3.75 oz)
Row-to-row grounding clip	SS 301 with SS 304 M6 bolts	75 g (2.6 oz)
Row-to-row spacer	Black POM-grade plastic	5 g (0.18 oz)

InvisiMount Operating Conditions	
Temperature	-40° C to 90° C (-40° F to 194° F)
Max. Load (LRFD)	<ul style="list-style-type: none"> • 3000 Pa uplift • 6000 Pa downforce

Roof Attachment Hardware Supported by Design Tool	
Application	<ul style="list-style-type: none"> • Composition Shingle Rafter Attachment • Composition Shingle Roof Decking Attachment • Curved and Flat Tile Roof Attachment • Universal interface for other roof attachments

InvisiMount Component LRFD Capacities ²		
Mid clamp	Uplift	664 lbf
	Shear	540 lbf
End clamp	Uplift	899 lbf
	Shear	220 lbf
Rail	Moment: upward	548 lbf-ft
	Moment: downward	580 lbf-ft
Rail splice	Moment: upward	548 lbf-ft
	Moment: downward	580 lbf-ft
L-foot	Uplift	1000 lbf
	Shear	390 lbf

InvisiMount Warranties And Certifications	
Warranties	<ul style="list-style-type: none"> • 25-year product warranty • 5-year finish warranty
Certifications	<ul style="list-style-type: none"> • UL 2703 Listed • Class A Fire Rated

Roof Attachment Hardware Warranties	
Refer to roof attachment hardware manufacturer's documentation.	

¹ Module frame that is compatible with the InvisiMount system required for hardware interoperability.
² SunPower recommends that all Equinox™, InvisiMount™, and AC module systems always be designed using the InvisiMount Span Tables #524734. If a designer decides to instead use the component capacities listed in this document to design a system, note that the capacities shown are Load and Resistance Factor Design (LRFD) design loads, and are NOT to be used for Allowable Stress Design (ASD) calculations; and that a licensed Professional Engineer (PE) must then stamp all calculations. If you have any questions please contact SunPower Technical Support at 1-855-977-7867.

© 2018 SunPower Corporation. All Rights Reserved. SUNPOWER, the SUNPOWER logo, EQUINOX, and INVISIMOUNT are trademarks or registered trademarks of SunPower Corporation. All other trademarks are the property of their respective owners. Specifications included in this datasheet are subject to change without notice.

COMP MOUNT – BLACK



WATERTIGHT FOR LIFE

Pegasus Solar's Comp Mount is a cost effective, high-quality option for rail installations on composition shingle roofs. Designed to last decades, the one-piece flashing with elevated cone means there is simply nothing to fail.



25-year Warranty

Manufactured with advanced materials and coating to outlast the roof itself



Superior Waterproofing

Tested to AC286 without sealant 0.9" elevated water seal



Code Compliant

Fully IBC/CBC Code Compliant
Exceeds ASCE 7-10 Standards



All-In-One Kit Packaging

Flashings, L-Feet and SS lags with bonded EPDM washers are included in each 24-pack

COMP MOUNT – BLACK

1. Drill pilot hole in center of rafter.



2. Optional: Apply a "U-shape" of sealant to underside of flashing and position under 2nd shingle course, cone over pilot hole.



3. Place L-Foot over cone and install lag with washer through L-Foot.

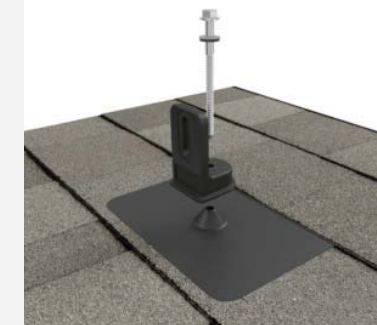

4. Drive lag to required depth. Attach rail per rail manufacturer's instructions.

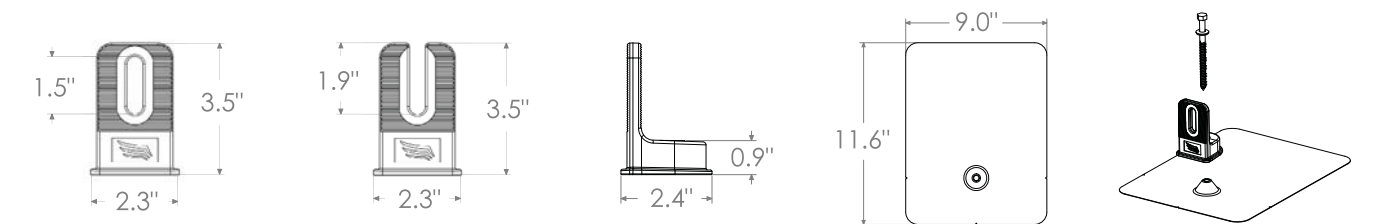

Specifications	Black Comp Mount Install Kits		
SKU	PSCR-C0	PSCR-UBB0	SPCR-CH
L-Foot Type	Closed Slot	Open Slot	Closed Slot
Kit Contents	L-Foot, Flashing, 5/16" x 4-1/2" SS Lag w/ EPDM washer	L-Foot, Flashing, 5/16" x 4-1/2" SS Lag w/ EPDM washer	L-Foot, Flashing, 5/16" x 4-1/2" SS Lag w/ EPDM washer, M10 Hex Bolt
Finish	Black L-Foot and Black Flashing		
Roof Type	Composition Shingle		
Certifications	IBC, ASCE/SEI 7-10, AC286		
Install Application	Railed Systems		
Compatible Rail	Most		
Flashing Material	Painted Galvalume Plus		
L-Foot Material	Aluminum		
Kit Quantity	24		
Boxes per Pallet	72		

Patents Pending. All rights reserved. © 2019 Pegasus Solar Inc

Eaton general duty cartridge fuse safety switch

DG222NRB

UPC:782113144221

Dimensions:

- **Height:** 14.37 IN
- **Length:** 7.35 IN
- **Width:** 8.4 IN

Weight:10 LB

Notes:Maximum hp ratings apply only when dual element fuses are used. 3-Phase hp rating shown is a grounded B phase rating, UL listed.

Warranties:

- Eaton Selling Policy 25-000, one (1) year from the date of installation of the Product or eighteen (18) months from the date of shipment of the Product, whichever occurs first.

Specifications:

- **Type:** General duty, cartridge fused
- **Amperage Rating:** 60A
- **Enclosure:** NEMA 3R
- **Enclosure Material:** Painted galvanized steel
- **Fuse Class Provision:** Class H fuses
- **Fuse Configuration:** Fusible with neutral
- **Number Of Poles:** Two-pole
- **Number Of Wires:** Three-wire
- **Product Category:** General duty safety switch
- **Voltage Rating:** 240V

Supporting documents:

- [Eatons Volume 2-Commercial Distribution](#)
- [Eaton Specification Sheet - DG222NRB](#)

Certifications:

- UL Listed

Product compliance: No Data



Eaton general duty non-fusible safety switch

DG222URB

UPC:782113144238

Dimensions:

- **Height:** 14.38 IN
- **Length:** 7.38 IN
- **Width:** 8.69 IN

Weight:9 LB

Notes:WARNING! Switch is not approved for service entrance unless a neutral kit is installed.

Warranties:

- Eaton Selling Policy 25-000, one (1) year from the date of installation of the Product or eighteen (18) months from the date of shipment of the Product, whichever occurs first.

Specifications:

- **Type:** Non-fusible, single-throw
- **Amperage Rating:** 60A
- **Enclosure:** NEMA 3R, Rainproof
- **Enclosure Material:** Painted galvanized steel
- **Fuse Configuration:** Non-fusible
- **Number Of Poles:** Two-pole
- **Number Of Wires:** Two-wire
- **Product Category:** General duty safety switch
- **Voltage Rating:** 240V

Supporting documents:

- [Eatons Volume 2-Commercial Distribution](#)
- [Eaton Specification Sheet - DG222URB](#)

Certifications:

- UL Listed

Product compliance: No Data



Eaton CH main lug loadcenter

CH8L125RP

UPC:782114190548

Dimensions:

- **Height:** 3.69 IN
- **Length:** 13 IN
- **Width:** 11 IN

Weight: 12 LB

Notes: Ground bar kits priced separately. Suitable for use as service equipment when not more than two service disconnecting mains are provided or when not used as a lighting and appliance panelboard.

Warranties:

- Limited lifetime

Specifications:

- **Special Features:** Cover included
- **Type:** Main lug only
- **Amperage Rating:** 125A
- **Box Size:** 7r
- **Bus Material:** Copper
- **Enclosure:** NEMA 3R
- **Enclosure Material:** Metallic
- **Feed Type:** Overhead
- **Main Circuit Breaker:** CH
- **Number Of Circuits:** 8
- **Number Of Wires:** Three-wire
- **Phase:** Single-phase
- **Voltage Rating:** 120/240V, 208Y/120, 240V
- **Wire Size:** #6-1/0 AWG

Supporting documents:

- [Type CH Circuit Breakers and Loadcenters](#)
- [Loadcenters and Circuit Breakers](#)
- [Eatons Volume 1-Residential and Light Commercial](#)



Eaton CH main lug loadcenter

CH12L125R

UPC:782113097381

Dimensions:

- **Height:** 5.19 IN
- **Length:** 16.75 IN
- **Width:** 14.31 IN

Weight: 15.8 LB

Notes: Suitable for use as service equipment when not more than six service disconnecting mains are provided or when not used as a lighting and appliance panelboard. Rainproof panels are furnished with hub closure plates. For rainproof hubs.

Warranties:

- Limited lifetime

Specifications:

- **Special Features:** Cover included
- **Type:** Main lug only
- **Amperage Rating:** 125A
- **Box Size:** B
- **Bus Material:** Copper
- **Enclosure:** NEMA 3R
- **Enclosure Material:** Metallic
- **Feed Type:** Overhead
- **Main Circuit Breaker:** CH
- **Number Of Circuits:** 12
- **Number Of Wires:** Three-wire
- **Phase:** Single-phase
- **Voltage Rating:** 120/240V
- **Wire Size:** #6-2/0 AWG

Supporting documents:

- [Dimensional Drawing - CH 3/4 LOADCENTER, MAIN LUG ONLY, OUTDOOR NEMA 3R, 120/240 VAC, 1 PH](#)



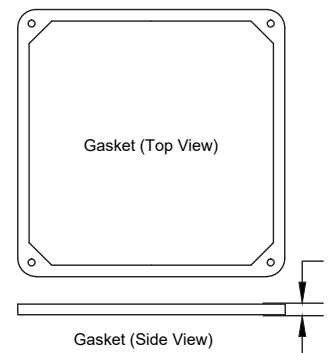
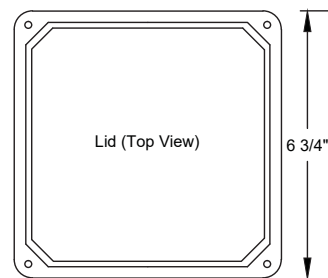
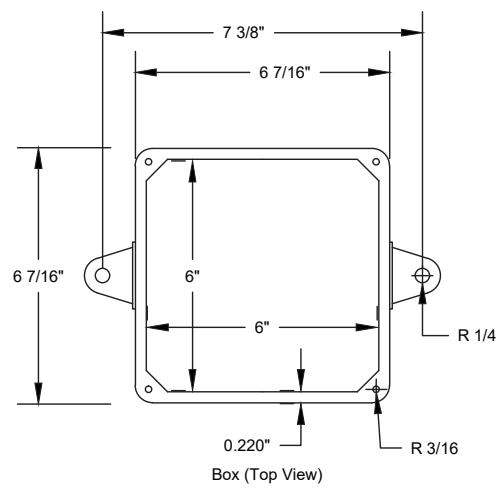
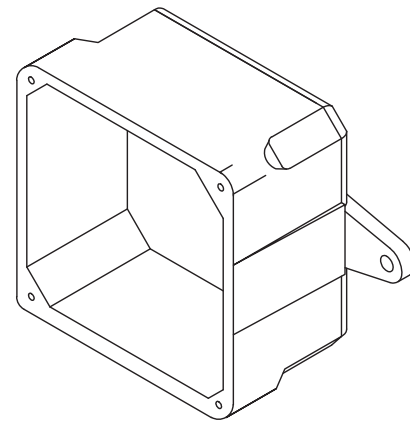
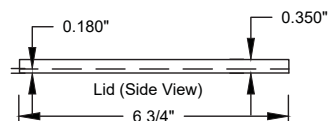
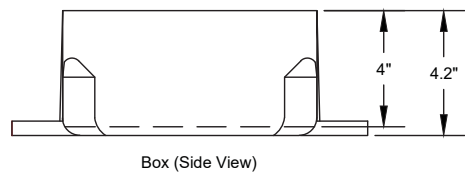

UL Listed
 Marine Listed
 UL File # E205935 (QCUP)
 UL Control # 92CM
 Material is Rigid PVC
 132 cu in Volume (2163 cu cm)
 Screws are Zinc Plated Steel
 Gasket is neoprene

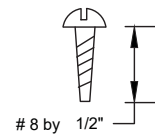

CANTEX INC. Fort Worth, TEXAS		
Junction Box 6 x 6 x 4		
Drawn By: O.M.	Date: 6/19/17	5133710

2.0 Listings, Compatibility, and Classification

The SunPower InvisiMount Residential Mounting System is UL 2703 Listed. The InvisiMount Listing **includes** the following SunPower InvisiMount-compatible modules, **which are the only modules that are compatible with the InvisiMount system:**

DC Modules	AC Modules	
<ul style="list-style-type: none"> • SPR-X22-370 • SPR-X22-360 • SPR-X21-350-BLK • SPR-X21-335-BLK • SPR-X21-345 • SPR-E20-327 • SPR-E19-320 	<ul style="list-style-type: none"> • SPR-X22-370-E-AC • SPR-X22-360-E-AC • SPR-X21-350-BLK-E-AC • SPR-X21-335-BLK-E-AC • SPR-X20-327-BLK-E-AC • SPR-X21-345-E-AC • SPR-X21-335-E-AC • SPR-X20-327-E-AC • SPR-E20-327-E-AC • SPR-E19-320-E-AC 	<ul style="list-style-type: none"> • SPR-A425-G-AC • SPR-A420-G-AC • SPR-A415-G-AC • SPR-A400-G-AC • SPR-A390-G-AC

Grounding from the module to the rail is accomplished through both the mid clamp and end clamp. The Listing also includes the following components, which have been evaluated for both mounting and bonding in accordance with UL 2703:

- end clamp
- mid clamp
- rail
- splice and splice screw
- ground lug assembly
- L-foot
- row-to-row (R2R) grounding clip
- row-to-row (R2R) spacer

