

© 2019 NC SOLAR NOW EXPRESSLY RESERVES ITS COMMON LAW COPYRIGHT AND OTHER PROPERTY RIGHTS IN THESE PLANS. THESE PLANS ARE NOT TO BE REPRODUCED, CHANGED OR COPIED IN ANY FORM OR MANNER WHATSOEVER, NOR ARE THEY TO BE ASSIGNED TO ANY THIRD PARTY WITHOUT FIRST OBTAINING THE EXPRESSED WRITTEN PERMISSION AND CONSENT OF NC SOLAR NOW.



PV MATERIAL SUMMARY: DISTRIBUTOR	
REC320NP BLACK (fulfillment)	48
P401	48
SE7600H-US000BNU4	1
SE6000H-US000BNI4	1
SE-CELL-B-R05-US-S-S2	2
SECT-SPL-225A-T-20	2
XR-10-168B	17
XR-10-204B	6
XR10-BOSS-01-M1	10
UFO-CL-01-B1	112
UFO-STP-30MM-B1	32
XR-LUG-03-A1	9
4 IN QB1	49
QB DECK MOUNT 16317	64
GC66803 Geocel Sealant	3
SOLADECK 0799-5B	3

**CLIENT INFO**  
 DARREN A HAWKINS  
 16 CYRA COURT  
 FUQUAY-VARINA, NC 27526

**PROJECT INFO**  
 DC INPUT: 15.360 kW  
 AC EXPORT: 13.600 kW  
 DOI INSP. METHOD: OPTION 2

**CODE REFERENCES**  
 NATION ELECTRICAL CODE v. 2017  
 NC FIRE PROTECTION CODE v. 2018  
 NC BUILDING CODE v. 2018  
 NC RESIDENTIAL CODE v. 2018  
 ACSE v. 7-10

**SITE CONDITIONS**  
 WIND SPEED: 116 MPH  
 RISK CATEGORY: II  
 EXPOSURE: B  
 SNOW: 15 PSF

**SHEET INDEX**  
 PV-1: COVER SHEET  
 PV-2: PV STRUCTURAL  
 PV-3: PV ELECTRICAL  
 PV-4: PV EQUIPMENT LABELS  
 PV-5: PV INSTALL GUIDE

**NOTICE TO CONTRACTOR**  
 All construction shall comply with current NC Building Codes and a signed City Inspection and verification.

APPROVED: **Harnett COUNTY**  
 NORTH CAROLINA  
 02/16/2022

**DESIGNER INFO**  
 DESIGNER: CRM  
 ENGINEER: AWK  
 DATE: 11/29/2021  
 VERSION: P1

**PV SYSTEM COVER PAGE**

**PV-1.1**

© 2019 NC SOLAR NOW EXPRESSLY RESERVES ITS COMMON LAW COPYRIGHT AND OTHER PROPERTY RIGHTS IN THESE PLANS. THESE PLANS ARE NOT TO BE REPRODUCED, CHANGED OR COPIED IN ANY FORM OR MANNER WHATSOEVER, NOR ARE THEY TO BE ASSIGNED TO ANY THIRD PARTY WITHOUT FIRST OBTAINING THE EXPRESSED WRITTEN PERMISSION AND CONSENT OF NC SOLAR NOW.

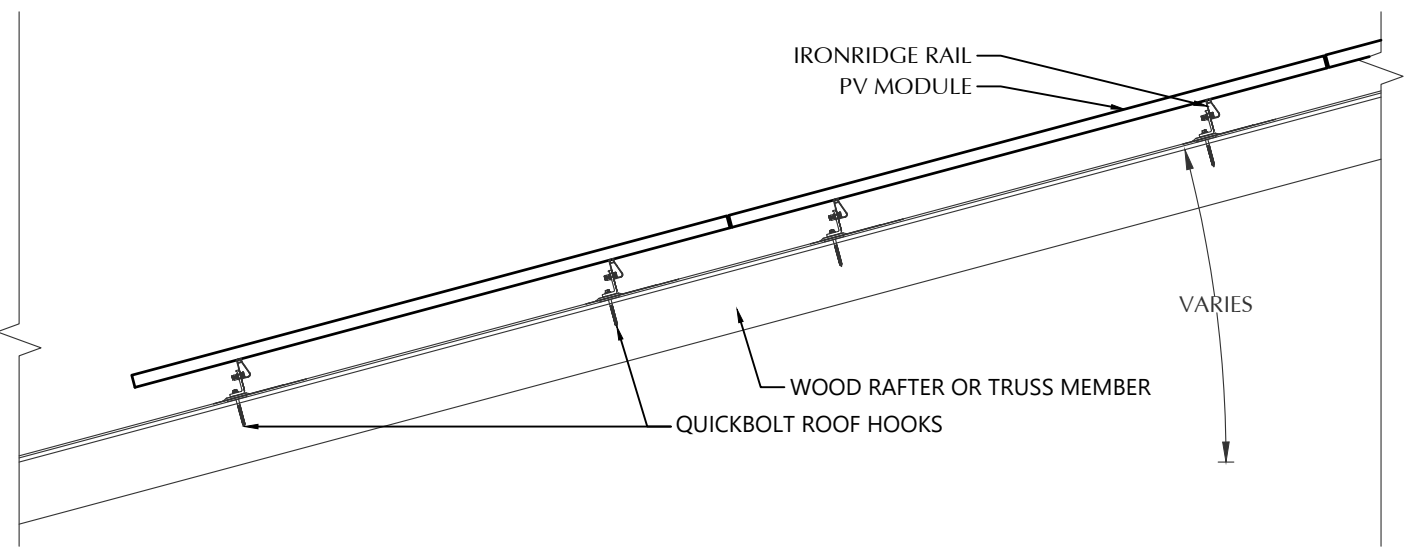

**STATEMENT OF STRUCTURAL COMPLIANCE**

THE EXISTING ROOF STRUCTURE HAS BEEN DESIGNED TO SUPPORT THE ADDITIONAL LOADS OF THE PROPOSED PV SYSTEM. IN ADDITION, THE RACKING AND FASTENING SYSTEM SHALL BE CAPABLE OF SECURING THE SYSTEM TO THE STRUCTURE UNDER DESIGN CONDITIONS WHEN INSTALLED PROPERLY AND IN ACCORDANCE WITH THE RACKING AND FASTENING ARRANGEMENT DETAILED WITHIN THESE DRAWINGS.

NAME: ANDREW W. KING, PE

SIGNED:

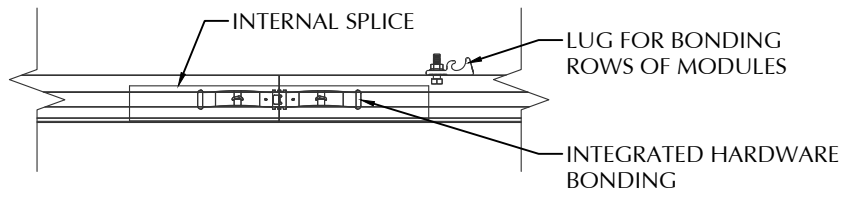

PV MODULES	
MAKE	REC
MODEL	REC320NP BLACK
WIDTH	39.25 IN
LENGTH	65.90 IN
THICKNESS	30 MM
WEIGHT	39.70 LBS.
ARRAY AREA	539 SQFT.
ARRAY WEIGHT	1347 LBS.

ROOF SUMMARY	
STRUCTURE:	
TYPE	TRUSSES
MATERIAL	SOUTHERN PINE #2
SIZE	2 X 4
SPACING	24 IN O.C.
ALLOWABLE SPAN	88 IN
PITCH	8/12
DENSITY	30 LBS./CU.FT.
DECKING:	
TYPE	OSB
MATERIAL	COMPOSITE
THICKNESS	7/16 IN
WEIGHT	1.60 LBS./SQFT
ROOFING:	
TYPE	ASPHALT SHINGLE
MATERIAL	ASPHALT
WEIGHT	2.30 LBS./SQFT.

ROOF MOUNT SUMMARY		
MAXIMUM (IN)	MOUNT SPACING	RAIL OVERHANG
WIND ZONE 1	72 IN	19 IN
WIND ZONE 2	48 IN	19 IN
WIND ZONE 3	48 IN	19 IN

ROOF LOADING	
GROUND SNOW LOAD:	15 LBS./SQFT.
LIVE LOAD	20 LBS./SQFT.
DEAD LOAD	
ROOFING	3.9 LBS./SQFT.
PV ARRAY	2.5 LBS./SQFT.
TOTAL	6.4 LBS./SQFT.
WIND LOAD:	
UPLIFT ZONE 1	-24.6 LBS./SQFT.
UPLIFT ZONE 2	-29.0 LBS./SQFT.
UPLIFT ZONE 3	-29.0 LBS./SQFT.
DOWNWARD	23.0 LBS./SQFT.
FASTENER LOAD:	
UPLIFT ZONE 1	-402 LBS.
UPLIFT ZONE 2	-316 LBS.
UPLIFT ZONE 3	-316 LBS.
DOWNWARD	376 LBS.

ROOF MOUNT & FASTENER	
ROOF MOUNT:	
MAKE	QUICKBOLT
MODEL	4 IN QB1
MATERIAL	STAINLESS / EPDM
FASTENER:	
MAKE	QUICK SCREWS
MODEL	HANGER BOLT
MATERIAL	304 SS
SIZE	5/16-18 X 5-1/4"
GENERAL:	
WEIGHT	0.56 LBS.
FASTENERS PER MOUNT	1
MAX. PULL-OUT FORCE	960.0 LBS.
SAFETY FACTOR	2
DESIGN PULL-OUT FORCE	480.0 LBS.

MOUNTING RAILS	
MAKE	IRONRIDGE
MODEL	XR10
MATERIAL	ALUMINUM
WEIGHT	0.425 LBS/IN
SPACING	33 IN

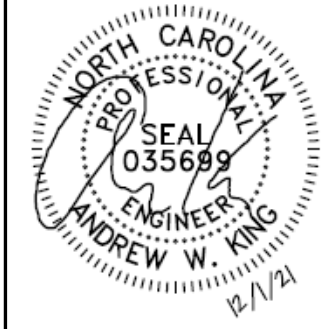

**CLIENT INFO**

DARREN A HAWKINS  
16 CYRA COURT  
FUQUAY-VARINA, NC 27526

**PROJECT INFO**

DC INPUT: 15.360 kW  
AC EXPORT: 13.600 kW  
DOI INSPT. METHOD: OPTION 2

**CODE REFERENCES**

NATION ELECTRICAL CODE v. 2017  
NC FIRE PROTECTION CODE v. 2018  
NC BUILDING CODE v. 2018  
NC RESIDENTIAL CODE v. 2018  
ACSE v. 7-10

**SITE CONDITIONS**

WIND SPEED: 116 MPH  
RISK CATEGORY: II  
EXPOSURE: B  
SNOW: 15 PSF

**SHEET INDEX**

PV-1: COVER SHEET  
PV-2: PV STRUCTURAL  
PV-3: PV ELECTRICAL  
PV-4: PV EQUIPMENT LABELS  
PV-5: PV INSTALL GUIDE

**DESIGNER INFO**

DESIGNER: CRM  
ENGINEER: AWK  
DATE: 11/29/2021  
VERSION: P1

**PV SYSTEM STRUCTURAL**

**PV-2.1**

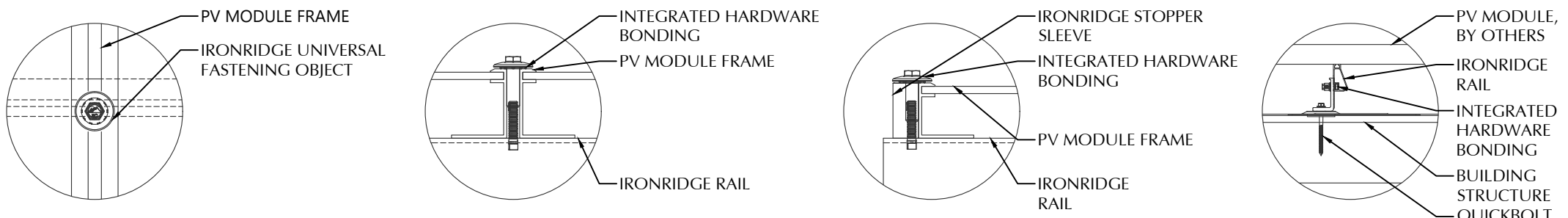

**1 ROOF FASTENER DETAIL**  
NOT TO SCALE

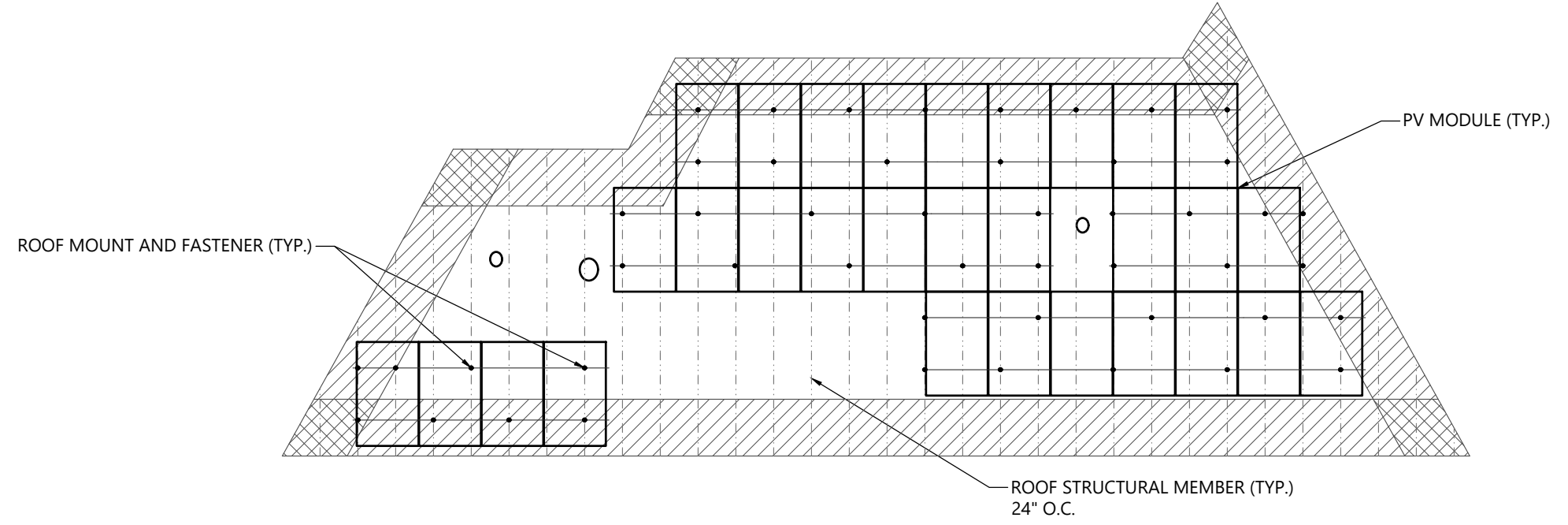

**2 ROOF A ARRAY LAYOUT**  
1/8" = 1'-0"

© 2019 NC SOLAR NOW EXPRESSLY RESERVES ITS COMMON LAW COPYRIGHT AND OTHER PROPERTY RIGHTS IN THESE PLANS. THESE PLANS ARE NOT TO BE REPRODUCED, CHANGED OR COPIED IN ANY FORM OR MANNER WHATSOEVER, NOR ARE THEY TO BE ASSIGNED TO ANY THIRD PARTY WITHOUT FIRST OBTAINING THE EXPRESSED WRITTEN PERMISSION AND CONSENT OF NC SOLAR NOW.

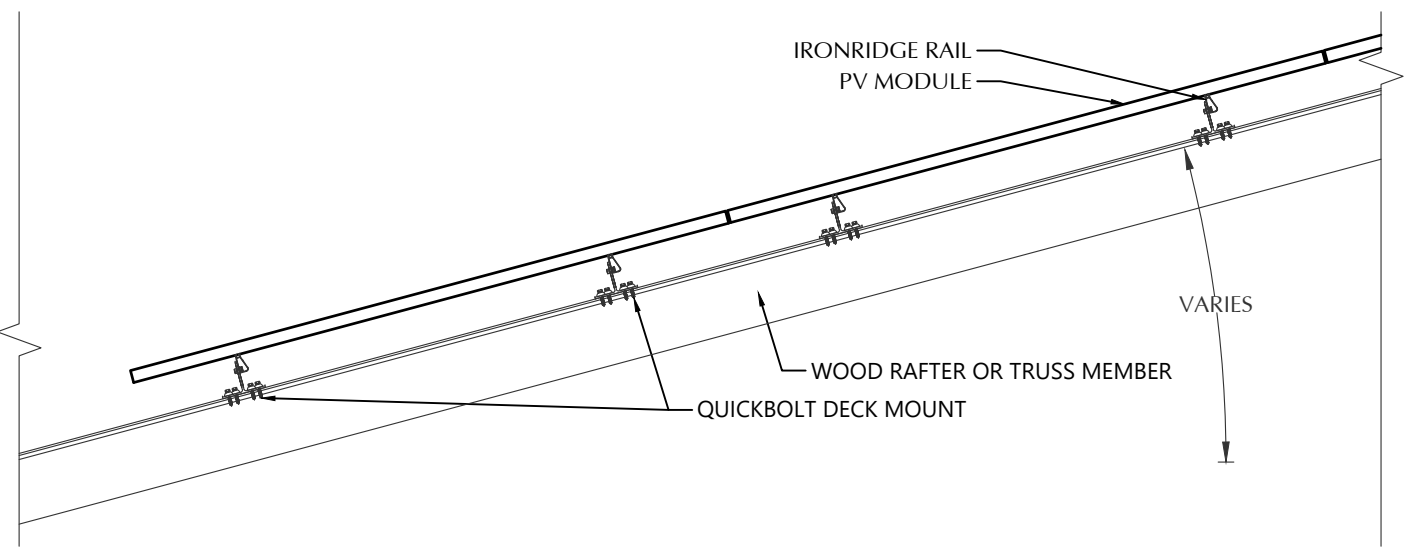

**STATEMENT OF STRUCTURAL COMPLIANCE**

THE EXISTING ROOF STRUCTURE HAS BEEN DESIGNED TO SUPPORT THE ADDITIONAL LOADS OF THE PROPOSED PV SYSTEM. IN ADDITION, THE RACKING AND FASTENING SYSTEM SHALL BE CAPABLE OF SECURING THE SYSTEM TO THE STRUCTURE UNDER DESIGN CONDITIONS WHEN INSTALLED PROPERLY AND IN ACCORDANCE WITH THE RACKING AND FASTENING ARRANGEMENT DETAILED WITHIN THESE DRAWINGS.

NAME: ANDREW W. KING, PE  
 SIGNED: *Andrew W. King*

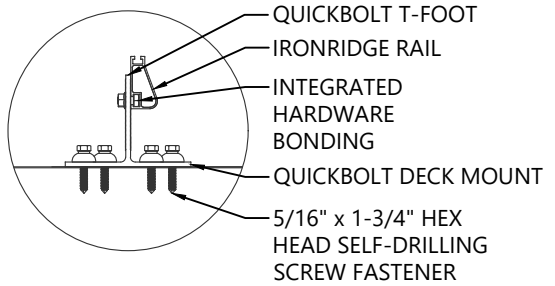
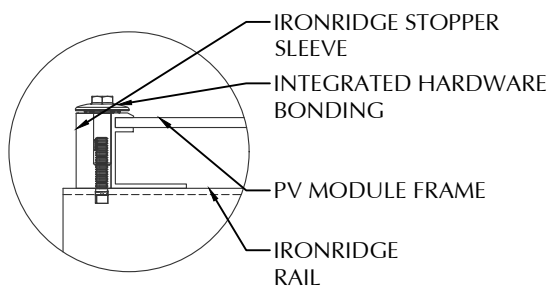
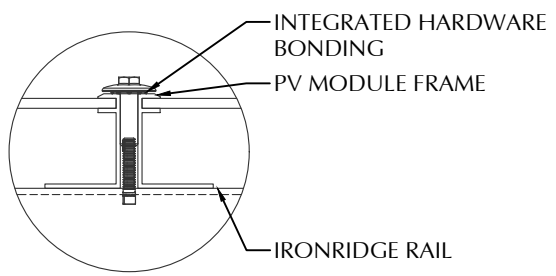
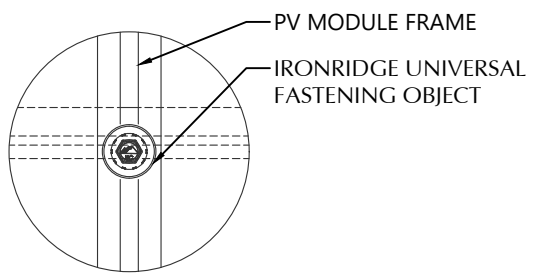
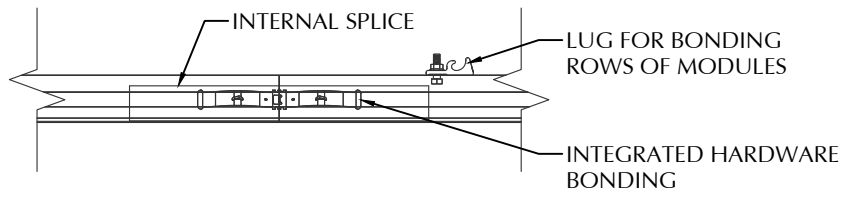

**1 ROOF FASTENER DETAIL**  
NOT TO SCALE

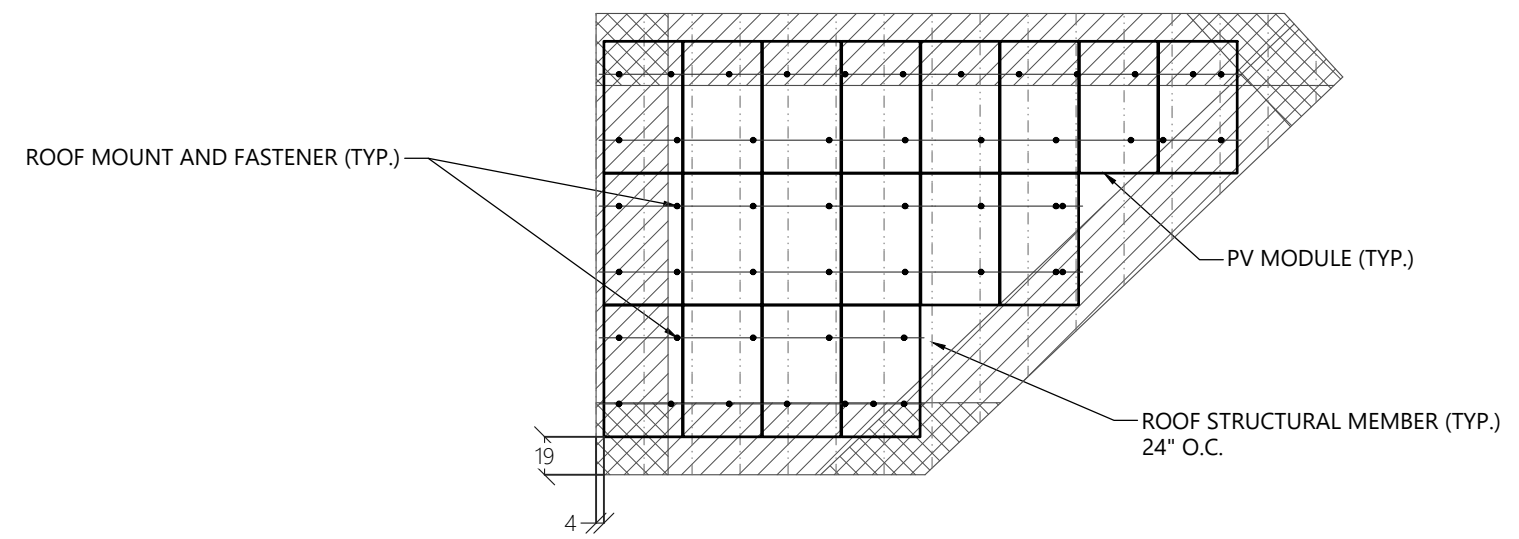

**2 ROOF B ARRAY LAYOUT**  
1/8" = 1'-0"

PV MODULES	
MAKE	REC
MODEL	REC320NP BLACK
WIDTH	39.25 IN
LENGTH	65.90 IN
THICKNESS	30 MM
WEIGHT	39.70 LBS.
ARRAY AREA	323 SQFT.
ARRAY WEIGHT	808 LBS.

ROOF SUMMARY	
STRUCTURE:	
TYPE	TRUSSES
MATERIAL	SOUTHERN PINE #2
SIZE	2 X 4
SPACING	24 IN O.C.
ALLOWABLE SPAN	88 IN
PITCH	12/12
DENSITY	30 LBS./CU.FT.
DECKING:	
TYPE	OSB
MATERIAL	COMPOSITE
THICKNESS	7/16 IN
WEIGHT	1.60 LBS./SQFT
ROOFING:	
TYPE	ASPHALT SHINGLE
MATERIAL	ASPHALT
WEIGHT	2.30 LBS./SQFT.

ROOF MOUNT SUMMARY		
MAXIMUM (IN)	MOUNT SPACING	RAIL OVERHANG
WIND ZONE 1	38 IN	11 IN
WIND ZONE 2	29 IN	11 IN
WIND ZONE 3	26 IN	10 IN

ROOF LOADING	
GROUND SNOW LOAD:	15 LBS./SQFT.
LIVE LOAD	20 LBS./SQFT.
DEAD LOAD	
ROOFING	3.9 LBS./SQFT.
PV ARRAY	2.5 LBS./SQFT.
TOTAL	6.4 LBS./SQFT.
WIND LOAD:	
UPLIFT ZONE 1	-26.9 LBS./SQFT.
UPLIFT ZONE 2	-32.4 LBS./SQFT.
UPLIFT ZONE 3	-32.4 LBS./SQFT.
DOWNWARD	24.7 LBS./SQFT.
FASTENER LOAD:	
UPLIFT ZONE 1	-232 LBS.
UPLIFT ZONE 2	-213 LBS.
UPLIFT ZONE 3	-191 LBS.
DOWNWARD	213 LBS.

ROOF MOUNT & FASTENER	
ROOF MOUNT:	
MAKE	QUICKBOLT
MODEL	QB DECK MOUNT 16317
MATERIAL	STAINLESS / EPDM
FASTENER:	
MAKE	QUICK SCREWS
MODEL	HEX LAG PN# 16318
MATERIAL	304 SS
SIZE	5/16" X 1-3/4"
GENERAL:	
WEIGHT	0.88 LBS.
FASTENERS PER MOUNT	4
MAX. PULL-OUT FORCE	705.0 LBS.
SAFETY FACTOR	3
DESIGN PULL-OUT FORCE	235.0 LBS.

MOUNTING RAILS	
MAKE	IRONRIDGE
MODEL	XR10
MATERIAL	ALUMINUM
WEIGHT	0.425 LBS./IN
SPACING	33 IN

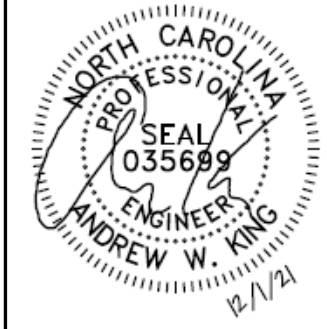

**CLIENT INFO**

DARREN A HAWKINS  
 16 CYRA COURT  
 FUQUAY-VARINA, NC 27526

**PROJECT INFO**

DC INPUT: 15.360 kW  
 AC EXPORT: 13.600 kW  
 DOI INSPT. METHOD: OPTION 2

**CODE REFERENCES**

NATION ELECTRICAL CODE v. 2017  
 NC FIRE PROTECTION CODE v. 2018  
 NC BUILDING CODE v. 2018  
 NC RESIDENTIAL CODE v. 2018  
 ACSE v. 7-10

**SITE CONDITIONS**

WIND SPEED: 116 MPH  
 RISK CATEGORY: II  
 EXPOSURE: B  
 SNOW: 15 PSF

**SHEET INDEX**

PV-1: COVER SHEET  
 PV-2: PV STRUCTURAL  
 PV-3: PV ELECTRICAL  
 PV-4: PV EQUIPMENT LABELS  
 PV-5: PV INSTALL GUIDE

**DESIGNER INFO**

DESIGNER: CRM  
 ENGINEER: AWK  
 DATE: 11/29/2021  
 VERSION: P1

**PV SYSTEM STRUCTURAL**

**PV-2.2**

© 2019 NC SOLAR NOW EXPRESSLY RESERVES ITS COMMON LAW COPYRIGHT AND OTHER PROPERTY RIGHTS IN THESE PLANS. THESE PLANS ARE NOT TO BE REPRODUCED, CHANGED OR COPIED IN ANY FORM OR MANNER WHATSOEVER, NOR ARE THEY TO BE ASSIGNED TO ANY THIRD PARTY WITHOUT FIRST OBTAINING THE EXPRESSED WRITTEN PERMISSION AND CONSENT OF NC SOLAR NOW.

## CONDUCTOR SCHEDULE

TAG	CURRENT CARRYING CONDUCTORS			GROUNDING CONDUCTORS			CONDUIT/RACEWAY			NOTES
	QTY.	SIZE	INSULATION	QTY.	SIZE	INSULATION	QTY.	SIZE	LOCATION	
C1	8	10 AWG	PV WIRE	1	6 AWG	BARE	-	-	FREE AIR	1
C2	4	10 AWG	THWN	1	10 AWG	THWN	1	3/4"	EXT/INT	2,4
C3	3	8 AWG	THWN	1	10 AWG	THWN	1	3/4"	EXTERIOR	2,4
C4	3	4 AWG	THWN	1	8 AWG	THWN	1	1"	EXTERIOR	2,4
XC	-	-	-	-	-	-	-	-	-	3

**NOTES:**

1. MANUFACTURER PROVIDED, UL LISTED WIRING HARNESS FOR USE ON EXPOSED ROOFS
2. CONDUIT SIZE SHOWN IS CODE MINIMUM. LARGER SIZES ARE ALLOWED.
3. EXISTING CONDUCTORS, FIELD VERIFY
4. EQUIPMENT TERMINAL RATING SHALL BE A MINIMUM OF 75°C AT BOTH END OF CONDUCTOR

PV MODULE	
MAKE	REC
MODEL	REC320NP BLACK
NOM. POWER (PNOM)	320 WATTS
NOM. VOLT. (VMPP)	34.2 VOLTS
O.C. VOLT (VOC)	40.8 VOLTS
MAX. SYS. VOLT.	1000 VOLTS
NOM. CURR. (IMPP)	9.4 AMPS
S.C. CURR. (ISC)	10.2 AMPS
TEMP. COEF. (PMPP)	-0.35 %/C
TEMP. COEF. (Voc)	-0.27 %/C
MAX SERIES FUSE	25 AMPS
UL LIST. (Y/N)	YES

PV COMBINER PANEL	
MAKE	GENERIC
MODEL	NA
ENCL. RATING	NEMA 3R
VOLT. RATING	240 VOLTS
BUS RATING	125 AMPS
UL LIST. (Y/N)	YES
MAIN BREAKER (Y/N)	NO
MAIN BREAKER RATING	N/A

AC DISCONNECT	
MAKE	GENERIC
MODEL	NA
ENCL. RATING	NEMA 3R
VOLT. RATING	240 VOLTS
AMP RATING	100 AMPS
UL LIST. (Y/N)	YES
FUSED (Y/N)	NO
FUSE RATING	N/A

- LOAD-BREAK RATED
- VISIBLE OPEN
- LOCKABLE IN OPEN POSITION
- INSTALL ADJACENT TO METER
- DISCONNECT TO BE READILY ACCESSIBLE TO UTILITY COMPANY PERSONNEL AT ALL TIMES

MODULE OPTIMIZER	
MAKE	SOLAREEDGE
MODEL	P401
DC INPUT:	
NOM. POWER	400 WATTS
VOLT. RANGE	8 to 60
MAX. CURR.	11.8 AMPS
DC OUTPUT:	
NOM. POWER	400 WATTS
MAX. VOLT.	60 VOLTS
MAX. CURR.	15 AMPS
MIN-MAX STRING	8-25 OPTIMIZERS
UL LIST. (Y/N)	YES

JUNCTION BOX	
MAKE	SOLADECK
PROTECT. RATING	NEMA TYPE 3R
UL LIST. (Y/N)	YES

MD PANEL (EXISTING)	
MAKE	SIEMENS
MODEL	NA
ENCL. RATING	NEMA 3R
VOLT. RATING	240
BUS RATING	200 AMPS
UL LIST. (Y/N)	YES
MAIN BREAKER (Y/N)	NO
MAIN BREAKER RATING	N/A

- BACK-FEED SOLAR OUTPUT VIA 40A BREAKER AT THE OPPOSITE END OF THE BUS BAR FROM EXISTING POWER SOURCE
- MAIN BREAKER SERVES AS SERVICE DISCONNECT SWITCH

DC/AC INVERTER 1	
MAKE	SOLAREEDGE
MODEL	SE6000H-US
TECHNOLOGY	TRANSFORMER-LESS
DC INPUT:	
MAX. POWER	9300 WATTS
VOLT. RANGE	350-480 VOLTS
NOM. VOLT.	380 VOLTS
MAX. CURRENT	16.5 AMPS
STRING INPUTS	2 STRINGS
AC OUTPUT:	
NOM. POWER	6000 WATTS
NOM. VOLT.	240 VOLTS
MAX. POWER	6000 WATTS
MAX. CURR.	25 AMPS
GFP (Y/N)	YES
GFCI (Y/N)	YES
AFCI (Y/N)	YES
DC DISC. (Y/N)	YES
RAPID SHUTDOWN	YES
FUSE RATING	15 AMPS
PORTECT. RATING	NEMA 3R

DC/AC INVERTER 2	
MAKE	SOLAREEDGE
MODEL	SE7600H-US
TECHNOLOGY	TRANSFORMER-LESS
DC INPUT:	
MAX. POWER	11800 WATTS
VOLT. RANGE	350-480 VOLTS
NOM. VOLT.	400 VOLTS
MAX. CURRENT	20 AMPS
STRING INPUTS	2 STRINGS
AC OUTPUT:	
NOM. POWER	7600 WATTS
NOM. VOLT.	240 VOLTS
MAX. POWER	7600 WATTS
MAX. CURR.	32 AMPS
GFP (Y/N)	YES
GFCI (Y/N)	YES
AFCI (Y/N)	YES
DC DISC. (Y/N)	YES
RAPID SHUTDOWN	YES
FUSE RATING	15 AMPS
PORTECT. RATING	NEMA 3R

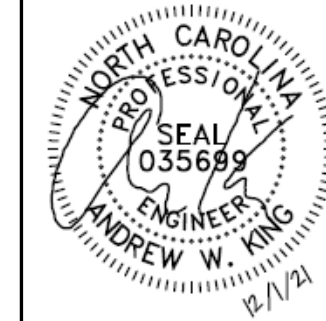

**CLIENT INFO**

DARREN A HAWKINS  
16 CYRA COURT  
FUQUAY-VARINA, NC 27526

**PROJECT INFO**

DC INPUT: 15.360 kW  
AC EXPORT: 13.600 kW  
DOI INSPT. METHOD: OPTION 2

**CODE REFERENCES**

NATION ELECTRICAL CODE v. 2017  
NC FIRE PROTECTION CODE v. 2018  
NC BUILDING CODE v. 2018  
NC RESIDENTIAL CODE v. 2018  
ACSE v. 7-10

**SITE CONDITIONS**

WIND SPEED: 116 MPH  
RISK CATEGORY: II  
EXPOSURE: B  
SNOW: 15 PSF

**SHEET INDEX**

PV-1: COVER SHEET  
PV-2: PV STRUCTURAL  
PV-3: PV ELECTRICAL  
PV-4: PV EQUIPMENT LABELS  
PV-5: PV INSTALL GUIDE

**DESIGNER INFO**

DESIGNER CRM  
ENGINEER AWK  
DATE 11/29/2021  
VERSION P1

**PV SYSTEM  
ELECTRICAL**

# PV-3.1

© 2019 NC SOLAR NOW EXPRESSLY RESERVES ITS COMMON LAW COPYRIGHT AND OTHER PROPERTY RIGHTS IN THESE PLANS. THESE PLANS ARE NOT TO BE REPRODUCED, CHANGED OR COPIED IN ANY FORM OR MANNER WHATSOEVER, NOR ARE THEY TO BE ASSIGNED TO ANY THIRD PARTY WITHOUT FIRST OBTAINING THE EXPRESSED WRITTEN PERMISSION AND CONSENT OF NC SOLAR NOW.

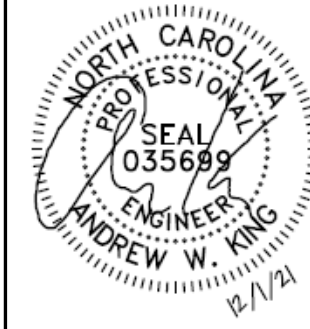

**1 ELECTRICAL SCHEMATIC**  
NTS

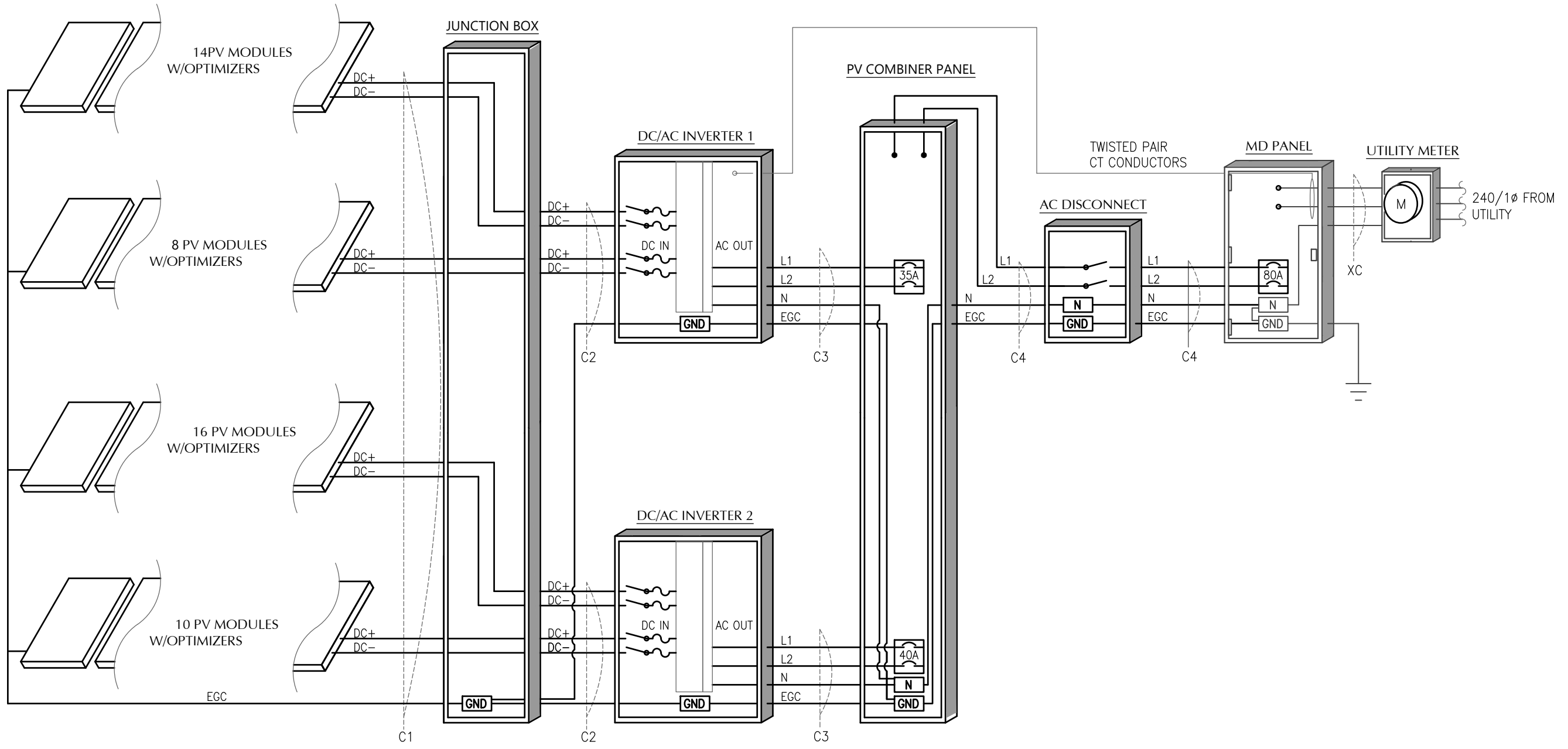

**CLIENT INFO**

DARREN A HAWKINS  
16 CYRA COURT  
FUQUAY-VARINA, NC 27526

**PROJECT INFO**

DC INPUT: 15.360 kW  
AC EXPORT: 13.600 kW  
DOI INSP. METHOD: OPTION 2

**CODE REFERENCES**

NATION ELECTRICAL CODE v. 2017  
NC FIRE PROTECTION CODE v. 2018  
NC BUILDING CODE v. 2018  
NC RESIDENTIAL CODE v. 2018  
ACSE v. 7-10

**SITE CONDITIONS**

WIND SPEED: 116 MPH  
RISK CATEGORY: II  
EXPOSURE: B  
SNOW: 15 PSF

**SHEET INDEX**

PV-1: COVER SHEET  
PV-2: PV STRUCTURAL  
PV-3: PV ELECTRICAL  
PV-4: PV EQUIPMENT LABELS  
PV-5: PV INSTALL GUIDE

**DESIGNER INFO**

DESIGNER: CRM  
ENGINEER: AWK  
DATE: 11/29/2021  
VERSION: P1

**PV SYSTEM  
ELECTRICAL**

**PV-3.2**

© 2019 NC SOLAR NOW EXPRESSLY RESERVES ITS COMMON LAW COPYRIGHT AND OTHER PROPERTY RIGHTS IN THESE PLANS. THESE PLANS ARE NOT TO BE REPRODUCED, CHANGED OR COPIED IN ANY FORM OR MANNER WHATSOEVER, NOR ARE THEY TO BE ASSIGNED TO ANY THIRD PARTY WITHOUT FIRST OBTAINING THE EXPRESSED WRITTEN PERMISSION AND CONSENT OF NC SOLAR NOW.

**⚠ WARNING**  
**ELECTRIC SHOCK HAZARD**  
 TERMINALS ON THE LINE AND LOAD SIDES MAY BE ENERGIZED IN THE OPEN POSITION

NEC 690.13 (B)  
 PLACE ON PV SYSTEM DISCONNECTING MEANS.

**⚠ WARNING**  
**POWER SOURCE OUTPUT CONNECTION DO NOT RELOCATE THIS OVERCURRENT DEVICE**

NEC 705.12 (B)(2)(3)(b)  
 PLACE ADJACENT TO BACK-FED BREAKER

**⚠ WARNING**  
**DUAL POWER SUPPLY**  
 SOURCES: UTILITY GRID AND PV SOLAR ELECTRIC SYSTEM

NEC 705.12 (B)(3)  
 PLACE ON ALL EQUIPMENT THAT IS SUPPLIED BY BOTH POWER SOURCES

**WARNING: PHOTOVOLTAIC POWER SOURCE**

NEC 690.31 (G)(3)&(4)  
 PLACE ON ALL JUNCTION BOXES, EXPOSED RACEWAYS, AND OTHER WIRING METHODS EVERY 10' AND ON EVERY SECTION SEPARATED BY ENCLOSURES, WALLS, PARTITIONS, CEILINGS, OR FLOORS.

**RAPID SHUTDOWN SWITCH FOR SOLAR PV SYSTEM**

NEC 690.56 (C)(3)  
 PLACE ON RAPID SHUTDOWN SWITCH OR EQUIPMENT WITH INTEGRATED RAPID SHUTDOWN \*REFLECTIVE\*

**SOLAR PV SYSTEM EQUIPPED WITH RAPID SHUTDOWN**

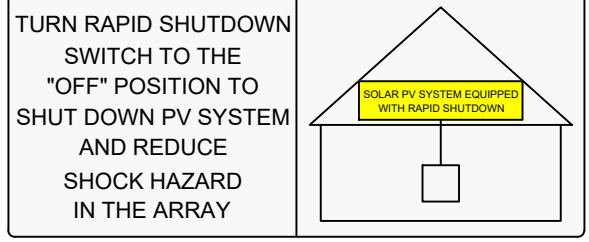

NEC 690.56 (C)(1)(a)  
 PLACE WITHIN 3FT OF SERVICE DISCONNECTING MEANS TO WHICH THE PV SYSTEMS ARE CONNECTED AND SHALL INDICATE THE LOCATIONS OF RAPID SHUTDOWN SWITCHES

**PV SYSTEM DISCONNECT**

NEC 690.13 (B)  
 PLACE ON PV SYSTEM DISCONNECTING MEANS.

**PHOTOVOLTAIC POWER SOURCE**  
 OPERATING AC VOLTAGE 240 V  
 MAXIMUM OPERATING AC OUTPUT CURRENT 57.0 A

NEC 690.54  
 PLACE ON INTERCONNECTION DISCONNECTING MEANS

**DIRECT CURRENT PHOTOVOLTAIC POWER SOURCE**  
 MAXIMUM VOLTAGE 600 VDC  
 MAX CIRCUIT CURRENT 30.0 AMPS

NEC 690.53  
 PLACE ON ALL DC DISCONNECTING MEANS

**⚠ WARNING**  
 THIS EQUIPMENT FED BY MULTIPLE SOURCES. TOTAL RATING OF ALL OVERCURRENT DEVICES EXCLUDING MAIN SUPPLY OVERCURRENT DEVICE SHALL NOT EXCEED AMPACITY OF BUSBAR.

NEC 705.12 (B)(2)(3)(c)  
 PLACE ON PV COMBINER PANEL.

**SERVICE DISCONNECT LOCATED: EXTERIOR SOUTH WALL OF RESIDENCE**  
**PV DISCONNECT LOCATED: EXTERIOR SOUTH WALL OF RESIDENCE**

NEC 705.10  
 PLACE AT SERVICE EQUIPMENT AND PV SYSTEM DISCONNECTING MEANS. FIELD VERIFY EQUIPMENT LOCATIONS AND LABEL ACCORDINGLY.

**LABEL NOTES**

1. LABELS SHOWN ARE HALF THEIR ACTUAL REQUIRED SIZE.
2. LABEL MATERIAL SHALL BE SUITABLE FOR THE EQUIPMENT ENVIRONMENT.
3. DC CONDUIT SHALL BE MARKED WITH REQUIRED LABEL EVERY 10 FEET.
4. LABELS WILL BE APPLIED IN ACCORDANCE WITH THE NEC. SOME LABELS MAY NOT BE NECESSARY.

**DC WIRING NOTES**

1. CONDUCTORS SHALL BE COPPER, RATED AT NOT LESS THAN 600 VOLTS FOR RESIDENTIAL CONSTRUCTION AND NOT LESS THAN 1000 VOLTS FOR COMMERCIAL CONSTRUCTION.
2. MINIMUM SIZE SHALL BE #10 AWG UNLESS OTHERWISE NOTED ON THE DRAWINGS.
3. EXPOSED WIRING CONDUCTOR INSULATION SHALL BE TYPE PV WIRE, USE-2, OR RHW-2 WHERE THE OUTER LAYER OF THE INSULATION IS UV, SUNLIGHT, AND MOISTURE RESISTANT.
6. EXTERIOR WIRING CONDUCTOR INSULATION SHALL BE TYPE THWN-2 AND INSTALLED IN ELECTRICAL METALLIC TUBING(EMT) OR RIGID POLYVINYL CHLORIDE CONDUIT(PVC). ALTERNATIVELY, METAL CLAD CABLE(MC) CAN BE USED AS WELL WHEN RATED FOR USE IN WET LOCATIONS.
7. INTERIOR WIRING CONDUCTOR INSULATION SHALL BE TYPE THHN-2 AND INSTALLED IN ELECTRICAL METALLIC TUBING(EMT), FLEXIBLE METAL CONDUIT(FMC), OR METAL CLAD CABLE(MC).
6. USE SCHEDULE 40 PVC OUTDOORS WHERE NOT SUBJECT TO PHYSICAL DAMAGE OR BELOW FLOOR SLAB. USE SCHEDULE 80 PVC OUTDOORS WHERE SUBJECT TO PHYSICAL DAMMAGE
7. MINIMUM CONDUIT SIZE TO BE 1/2".
8. WIRING METHODS TO CONFORM TO ARTICLES 330, 334, 348, 350, 352, 356, AND 358 OF THE 2017 NEC.

**AC WIRING NOTES**

1. CONDUCTORS SHALL BE COPPER RATED AT NOT LESS THAN 600 VOLTS.
2. MINIMUM SIZE SHALL BE #14 AWG UNLESS OTHERWISE NOTED ON THE DRAWINGS.
3. EXTERIOR WIRING CONDUCTOR INSULATION SHALL BE TYPE THWN AND INSTALLED IN ELECTRICAL METALLIC TUBING(EMT), RIGID POLYVINYL CHLORIDE CONDUIT(PVC), LIQUID-TIGHT FLEXIBLE METAL CONDUIT(LFMC), OR LIQUID-TIGHT FLEXIBLE NON-METALLIC CONDUIT(LFNC) . ALTERNATIVELY, METAL CLAD CABLE(MC) CAN BE USED AS WELL WHEN RATED FOR USE IN WET LOCATIONS.
4. INTERIOR WIRING CONDUCTOR INSULATION SHALL BE TYPE THHN AND INSTALLED IN ELECTRICAL METALLIC TUBING(EMT), FLEXIBLE METAL CONDUIT(FMC), METAL CLAD CABLE(MC), OR ROMEX.
5. USE SCHEDULE 40 PVC OUTDOORS WHERE NOT SUBJECT TO PHYSICAL DAMAGE OR BELOW FLOOR SLAB. USE SCHEDULE 80 PVC OUTDOORS WHERE SUBJECT TO PHYSICAL DAMMAGE
6. MINIMUM CONDUIT SIZE TO BE 1/2".
7. WIRING METHODS TO CONFORM TO ARTICLES 330, 334, 348, 350, 352, 356, AND 358 OF THE 2017 NEC.

**CONSTRUCTION NOTES**

1. ALL WORK IS TO BE PERFORMED IN ACCORDANCE WITH THE NEC, STATE, AND LOCAL APPLICABLE CODES.
2. FOLLOW MANUFACTURER'S INSTALLATION INSTRUCTIONS, BEST PRACTICES, AND SPECIFICATIONS.
3. ENSURE REQUIRED MAINTENANCE ACCESS AND CLEARANCES ARE MAINTAINED.
4. WIRES SHALL BE RATED AND LABELED "SUNLIGHT RESISTANT" WHERE EXPOSED TO AMBIENT CONDITIONS.
5. FUSES 0 - 600 AMPS SHALL BE UL CLASS "RK-1" LOW PEAK DUAL ELEMENT TIME DELAY WITH 200,000 AMPERE INTERRUPTING RATING AS MANUFACTURED BY BUSSMANN, UNLESS NOTED OTHERWISE.
6. ALL TERMINALS/LUGS SHALL BE 75° RATED. ALL TERMINALS, SPlicing CONNECTORS, LUGS, ETC SHALL BE IDENTIFIED FOR USE WITH THE MATERIAL (CU/AL) OF THE CONDUCTOR AND SHALL BE PROPERLY INSTALLED.
7. PROVIDE A PULLWIRE IN ALL EMPTY CONDUITS.
8. ALL PENETRATIONS THROUGH EXTERIOR ROOFS SHALL BE FLASHED IN A WATERPROOF MANNER.
9. ALL PENETRATIONS THROUGH ATTIC FIRE BARRIERS SHALL BE SEALED WITH FIRE-BARRIER SEALANT CAULK.
10. SUPPORT ALL CONDUIT AND EQUIPMENT IN ACCORDANCE W/ NEC. ANY SUSPENDED MATERIALS SHALL BE DIRECTLY SUPPORTED BY THE BUILDING STRUCTURE.
11. METAL CONDUIT COUPLINGS CAN BE COMPRESSION TYPE, THREADED, OR BE SET-SCREW TYPE. PLASTIC CONDUIT COUPLINGS TO BE SOCKET GLUED TYPE.
12. A COMPLETE GROUNDING SYSTEM SHALL BE PRESENT OR PROVIDED AND INSTALLED IN ACCORDANCE WITH ARTICLE 250 OF THE NEC, AND AS SHOWN ON THE DRAWINGS.
13. EACH ELECTRICAL APPLIANCE SHALL BE PROVIDED WITH A NAMEPLATE GIVING THE IDENTIFYING NAME AND THE RATING IN VOLTS AND AMPERES, OR VOLTS AND WATTS. IF THE APPLIANCE IS TO BE USED ON A SPECIFIC FREQUENCY OR FREQUENCIES, IT SHALL BE SO MARKED. WHERE MOTOR OVERLOAD PROTECTION EXTERNAL TO THE APPLIANCES IS REQUIRED, THE APPLIANCE SHALL BE SO MARKED.
14. WHERE APPLICABLE, GROUNDING ELECTRODE CONDUCTOR TO BE CONTINUOUS. GROUNDING CRIMPS TO BE IRREVERSIBLE.
15. PHOTOVOLTAIC SYSTEMS SHALL BE PERMANENTLY MARKED AT VARIOUS EQUIPMENT LOCATIONS TO IDENTIFY THAT A PHOTOVOLTAIC SYSTEM IS INSTALLED AND THAT VARIOUS DANGERS ARE PRESENT.
16. EACH PHOTOVOLTAIC SYSTEM DISCONNECTING MEANS SHALL BE PERMANENTLY MARKED TO IDENTIFY IT AS A PHOTOVOLTAIC SYSTEM DISCONNECT.
17. WHERE ALL TERMINALS OF A DISCONNECTING MEANS MAY BE ENERGIZED IN THE OPEN POSITION, A WARNING SIGN SHALL BE MOUNTED ON OR ADJACENT TO THE DISCONNECT.
18. A PERMANENT LABEL FOR THE DIRECT-CURRENT PHOTOVOLTAIC POWER SOURCE SHALL BE PROVIDED AT THE DC DISCONNECT MEANS.
19. A PERMANENT PLAQUE OR DIRECTORY, DENOTING ALL ELECTRIC POWER SOURCES SERVING THE PREMISES, SHALL BE INSTALLED AT EACH SERVICE EQUIPMENT LOCATION AND AT LOCATIONS OF ALL POWER PRODUCTION SOURCES.
20. ALL MODULE GROUND CONNECTIONS SHALL BE MADE IN ACCORDANCE WITH NEC SECTION 690.4 (C)
21. A NORTH CAROLINA REGISTERED DESIGN PROFESSIONAL WILL BE REQUIRED TO SEAL THE STRUCTURAL DESIGN AT THE TIME OF PERMIT APPLICATION IF ANY OF THE FOLLOWING EXIST AND ARE ATTESTED TO BY THE APPLICANT:
  - I. THE WEIGHT OF THE PV SYSTEM EXCEEDS THREE (3) POUNDS PER SQUARE FOOT(PSF)
  - II. THE ROOF POSSESSES MORE THAN ONE (1) LAYER OF ASPHALT SHINGLES
  - III. THE ROOFING MATERIAL CONSISTS OF A TYPE OTHER THAN ASPHALT SHINGLES OR METAL
  - IV. THE ROOF IS LOCATED IN A 140 MPH OR GREATER WIND ZONE

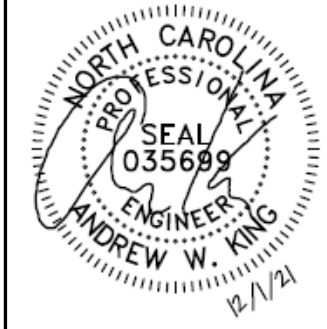

**CLIENT INFO**

DARREN A HAWKINS  
 16 CYRA COURT  
 FUQUAY-VARINA, NC 27526

**PROJECT INFO**

DC INPUT: 15.360 kW  
 AC EXPORT: 13.600 kW  
 DOI INSP. METHOD: OPTION 2

**CODE REFERENCES**

NATION ELECTRICAL CODE v. 2017  
 NC FIRE PROTECTION CODE v. 2018  
 NC BUILDING CODE v. 2018  
 NC RESIDENTIAL CODE v. 2018  
 ACSE v. 7-10

**SITE CONDITIONS**

WIND SPEED: 116 MPH  
 RISK CATEGORY: II  
 EXPOSURE: B  
 SNOW: 15 PSF

**SHEET INDEX**

PV-1: COVER SHEET  
 PV-2: PV STRUCTURAL  
 PV-3: PV ELECTRICAL  
 PV-4: PV EQUIPMENT LABELS  
 PV-5: PV INSTALL GUIDE

**DESIGNER INFO**

DESIGNER: CRM  
 ENGINEER: AWK  
 DATE: 11/29/2021  
 VERSION: P1

**PV SYSTEM EQUIPMENT LABELS**

**PV-4.1**

© 2019 NC SOLAR NOW EXPRESSLY RESERVES ITS COMMON LAW COPYRIGHT AND OTHER PROPERTY RIGHTS IN THESE PLANS. THESE PLANS ARE NOT TO BE REPRODUCED, CHANGED OR COPIED IN ANY FORM OR MANNER WHATSOEVER, NOR ARE THEY TO BE ASSIGNED TO ANY THIRD PARTY WITHOUT FIRST OBTAINING THE EXPRESSED WRITTEN PERMISSION AND CONSENT OF NC SOLAR NOW.

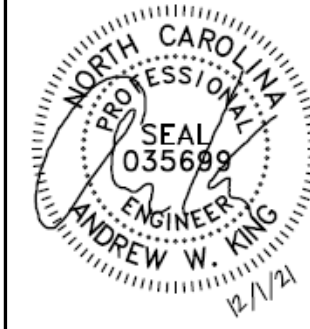
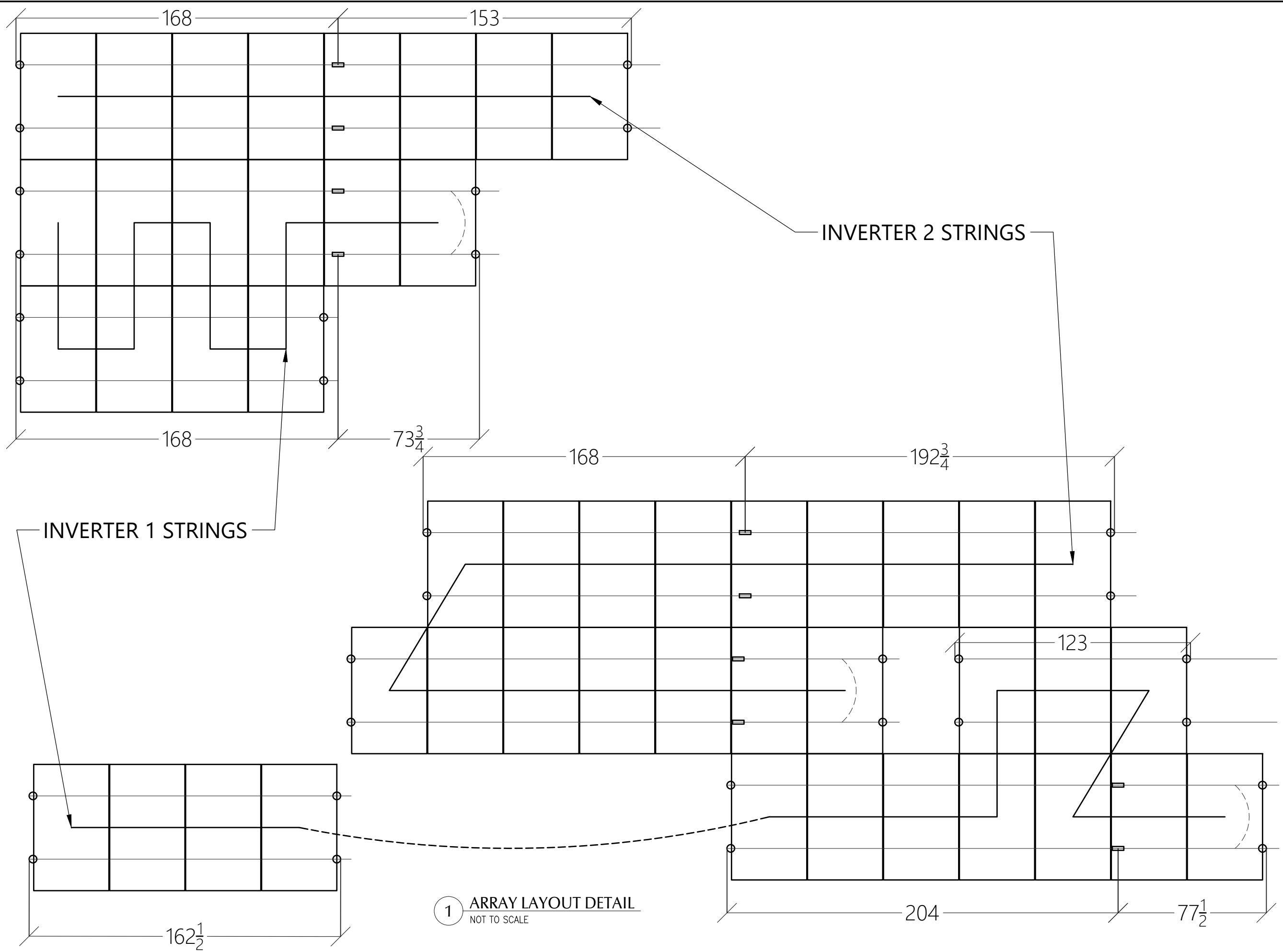

**CLIENT INFO**

DARREN A HAWKINS  
 16 CYRA COURT  
 FUQUAY-VARINA, NC 27526

**PROJECT INFO**

DC INPUT: 15.360 kW  
 AC EXPORT: 13.600 kW  
 DOI INSPT. METHOD: OPTION 2

**CODE REFERENCES**

NATION ELECTRICAL CODE v. 2017  
 NC FIRE PROTECTION CODE v. 2018  
 NC BUILDING CODE v. 2018  
 NC RESIDENTIAL CODE v. 2018  
 ACSE v. 7-10

**SITE CONDITIONS**

WIND SPEED: 116 MPH  
 RISK CATEGORY: II  
 EXPOSURE: B  
 SNOW: 15 PSF

**SHEET INDEX**

PV-1: COVER SHEET  
 PV-2: PV STRUCTURAL  
 PV-3: PV ELECTRICAL  
 PV-4: PV EQUIPMENT LABELS  
 PV-5: PV INSTALL GUIDE

**DESIGNER INFO**

DESIGNER: CRM  
 ENGINEER: AWK  
 DATE: 11/29/2021  
 VERSION: P1

**PV SYSTEM INSTALL GUIDE**

**PV-5.1**

SOLAR'S MOST TRUSTED



# REC N-PEAK 2 BLACK SERIES

PREMIUM FULL BLACK MONO  
N-TYPE SOLAR PANELS



MONO N-TYPE: THE  
MOST EFFICIENT C-SI  
TECHNOLOGY



NO LIGHT INDUCED  
DEGRADATION



SUPER-STRONG  
FRAME UP TO 7000 PA  
SNOW LOAD



FLEXIBLE  
INSTALLATION  
OPTIONS



FEATURING REC'S  
PIONEERING  
TWIN DESIGN



HIGH POWER  
FOR 25 YEARS

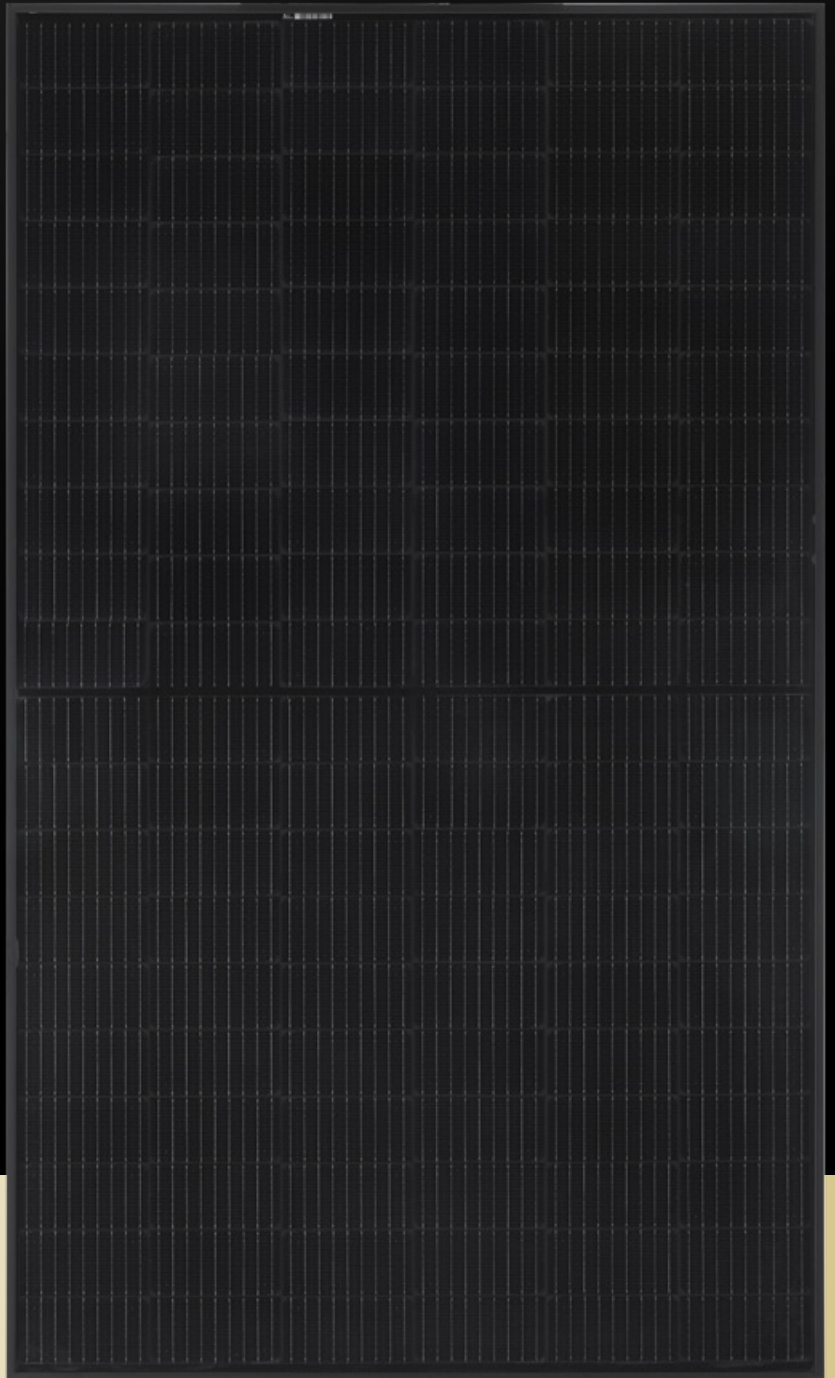

370  
WP  
POWER



ELIGIBLE



# REC N-PEAK 2 BLACK SERIES

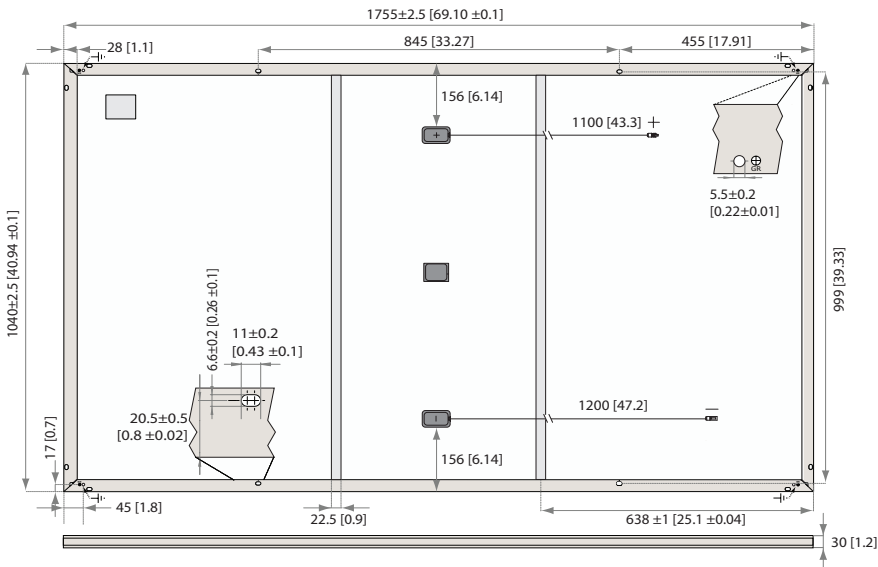

Measurements in mm [in]

## ELECTRICAL DATA @ STC

### Product code\*: RECxxxNP2 Black

	355	360	365	370
Nominal Power - $P_{MAX}$ (Wp)	355	360	365	370
Watt Class Sorting - (W)	0/+5	0/+5	0/+5	0/+5
Nominal Power Voltage - $V_{MPP}$ (V)	33.5	33.9	34.3	34.7
Nominal Power Current - $I_{MPP}$ (A)	10.60	10.62	10.65	10.68
Open Circuit Voltage - $V_{OC}$ (V)	40.7	40.8	40.9	41.1
Short Circuit Current - $I_{SC}$ (A)	11.27	11.31	11.36	11.41
Panel Efficiency (%)	19.4	19.7	20.0	20.3

Values at standard test conditions (STC: air mass AM1.5, irradiance 1000 W/m<sup>2</sup>, temperature 25°C), based on a production spread with a tolerance of  $P_{MAX}$ ,  $V_{OC}$  &  $I_{SC}$  ±3% within one watt class. \* Where xxx indicates the nominal power class ( $P_{MAX}$ ) at STC above.

## ELECTRICAL DATA @ NOCT

### Product code\*: RECxxxNP2 Black

	268	272	276	280
Nominal Power - $P_{MAX}$ (Wp)	268	272	276	280
Nominal Power Voltage - $V_{MPP}$ (V)	31.3	31.7	32.1	32.5
Nominal Power Current - $I_{MPP}$ (A)	8.56	8.58	8.60	8.63
Open Circuit Voltage - $V_{OC}$ (V)	38.1	38.2	38.2	38.4
Short Circuit Current - $I_{SC}$ (A)	9.10	9.13	9.18	9.22

Nominal operating cell temperature (NOCT: air mass AM1.5, irradiance 800 W/m<sup>2</sup>, temperature 20°C, windspeed 1 m/s). \* Where xxx indicates the nominal power class ( $P_{MAX}$ ) at STC above.

## CERTIFICATIONS

IEC 61215:2016, IEC 61730:2016, UL 61730 (Pending)  
ISO 14001:2004, ISO 9001:2015, OHSAS 18001:2007,  
IEC 62941



## WARRANTY

	Standard	RECProTrust	
Installed by an REC Certified Solar Professional	No	Yes	Yes
System size	any	≤25kW	25-500kW
Product Warranty (yrs)	20	25	25
Power Warranty (yrs)	25	25	25
Labor Warranty (yrs)	0	25	10
Power in Year 1	98%	98%	98%
Annual Degradation	0.25%	0.25%	0.25%
Power in Year 25	92%	92%	92%

See warranty documents for details. Some conditions apply.

## GENERAL DATA

Cell type:	120 half-cut mono c-Si n-type cells 6 strings of 20 cells in series
Glass:	0.13" (3.2 mm) solar glass with anti-reflection surface treatment
Backsheet:	Highly resistant polymeric construction (black)
Frame:	Anodized aluminum (black)
Junction box:	3-part, 3 bypass diodes, IP68 rated in accordance with IEC 62790
Cable:	12 AWG (4 mm <sup>2</sup> ) PV wire, 43 + 47" (1.1 m + 1.2 m) in accordance with EN 50618
Connectors:	Stäubli MC4 PV-KBT4/KST4, 12 AWG (4 mm <sup>2</sup> ) in accordance with IEC 62852 IP68 only when connected
Origin:	Made in Singapore

## MECHANICAL DATA

Dimensions:	69.1 x 40.94 x 1.2 in (1755 x 1040 x 30 mm)
Area:	19.70 sq ft (1.83 m <sup>2</sup> )
Weight:	44.0 lbs (20.0 kg)

## MAXIMUM RATINGS

Operational temperature:	-40 ... +85°C
Maximum system voltage:	1000 V
Maximum test load (front):	+7000 Pa (146 psf)*
Maximum test load (rear):	-4000 Pa (83.5 psf)*
Max series fuse rating:	25 A
Max reverse current:	25 A

\* See installation manual for mounting instructions.  
Design load = Test load / 1.5 (safety factor)

## TEMPERATURE RATINGS \*

Nominal Operating Cell Temperature:	44.3°C (±2°C)
Temperature coefficient of $P_{MAX}$ :	-0.34 %/°C
Temperature coefficient of $V_{OC}$ :	-0.26 %/°C
Temperature coefficient of $I_{SC}$ :	0.04 %/°C

\*The temperature coefficients stated are linear values

## LOW LIGHT BEHAVIOUR

Typical low irradiance performance of module at STC.

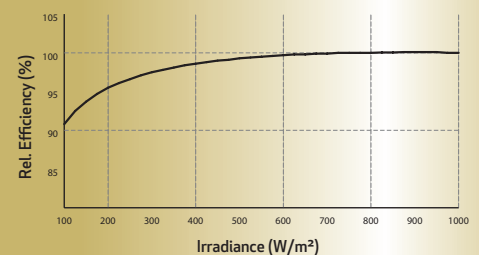

Founded in 1996, REC Group is an international pioneering solar energy company dedicated to empowering consumers with clean, affordable solar power. As Solar's Most Trusted, REC is committed to high quality, innovation, and a low carbon footprint in the solar materials and solar panels it manufactures. Headquartered in Norway with operational headquarters in Singapore, REC also has regional hubs in North America, Europe, and Asia-Pacific.

# Single Phase Inverter with HD-Wave Technology

for North America

SE3000H-US / SE3800H-US / SE5000H-US / SE6000H-US /  
SE7600H-US / SE10000H-US / SE11400H-US



## Optimized installation with HD-Wave technology

- Specifically designed to work with power optimizers
- Record-breaking efficiency
- Quick and easy inverter commissioning directly from a smartphone using the SolarEdge SetApp
- Fixed voltage inverter for longer strings
- Integrated arc fault protection and rapid shutdown for NEC 2014 and 2017, per article 690.11 and 690.12
- UL1741 SA certified, for CPUC Rule 21 grid compliance
- Extremely small
- Built-in module-level monitoring
- Outdoor and indoor installation
- Optional: Revenue grade data, ANSI C12.20 Class 0.5 (0.5% accuracy)

# / Single Phase Inverter with HD-Wave Technology for North America

SE3000H-US / SE3800H-US / SE5000H-US / SE6000H-US/  
SE7600H-US / SE10000H-US / SE11400H-US

Model Number	SE3000H-US	SE3800H-US	SE5000H-US	SE6000H-US	SE7600H-US	SE10000H-US	SE11400H-US	
APPLICABLE TO INVERTERS WITH PART NUMBER	SEXXXXH-XXXXXBXX4							
<b>OUTPUT</b>								
Rated AC Power Output	3000	3800 @ 240V 3300 @ 208V	5000	6000 @ 240V 5000 @ 208V	7600	10000	11400 @ 240V 10000 @ 208V	VA
Maximum AC Power Output	3000	3800 @ 240V 3300 @ 208V	5000	6000 @ 240V 5000 @ 208V	7600	10000	11400 @ 240V 10000 @ 208V	VA
AC Output Voltage Min.-Nom.-Max. (211 - 240 - 264)	✓	✓	✓	✓	✓	✓	✓	Vac
AC Output Voltage Min.-Nom.-Max. (183 - 208 - 229)	-	✓	-	✓	-	-	✓	Vac
AC Frequency (Nominal)	59.3 - 60 - 60.5 <sup>(1)</sup>							Hz
Maximum Continuous Output Current @240V	12.5	16	21	25	32	42	47.5	A
Maximum Continuous Output Current @208V	-	16	-	24	-	-	48.5	A
Power Factor	1, adjustable -0.85 to 0.85							
GFDI Threshold	1							A
Utility Monitoring, Islanding Protection, Country Configurable Thresholds	Yes							
<b>INPUT</b>								
Maximum DC Power @240V	4650	5900	7750	9300	11800	15500	17650	W
Maximum DC Power @208V	-	5100	-	7750	-	-	15500	W
Transformer-less, Ungrounded	Yes							
Maximum Input Voltage	480							Vdc
Nominal DC Input Voltage	380				400			Vdc
Maximum Input Current @240V <sup>(2)</sup>	8.5	10.5	13.5	16.5	20	27	30.5	Adc
Maximum Input Current @208V <sup>(2)</sup>	-	9	-	13.5	-	-	27	Adc
Max. Input Short Circuit Current	45							Adc
Reverse-Polarity Protection	Yes							
Ground-Fault Isolation Detection	600k $\Omega$ Sensitivity							
Maximum Inverter Efficiency	99	99.2						%
CEC Weighted Efficiency	99						99 @ 240V 98.5 @ 208V	%
Nighttime Power Consumption	< 2.5							W

<sup>(1)</sup> For other regional settings please contact SolarEdge support

<sup>(2)</sup> A higher current source may be used; the inverter will limit its input current to the values stated

# / Single Phase Inverter with HD-Wave Technology for North America

SE3000H-US / SE3800H-US / SE5000H-US / SE6000H-US/  
SE7600H-US / SE10000H-US / SE11400H-US

Model Number	SE3000H-US	SE3800H-US	SE5000H-US	SE6000H-US	SE7600H-US	SE10000H-US	SE11400H-US	
<b>ADDITIONAL FEATURES</b>								
Supported Communication Interfaces	RS485, Ethernet, ZigBee (optional), Cellular (optional)							
Revenue Grade Data, ANSI C12.20	Optional <sup>(3)</sup>							
Inverter Commissioning	with the SetApp mobile application using built-in Wi-Fi Access Point for local connection							
Rapid Shutdown - NEC 2014 and 2017 690.12	Automatic Rapid Shutdown upon AC Grid Disconnect							
<b>STANDARD COMPLIANCE</b>								
Safety	UL1741, UL1741 SA, UL1699B, CSA C22.2, Canadian AFCI according to T.I.L. M-07							
Grid Connection Standards	IEEE1547, Rule 21, Rule 14 (HI)							
Emissions	FCC Part 15 Class B							
<b>INSTALLATION SPECIFICATIONS</b>								
AC Output Conduit Size / AWG Range	1" Maximum / 14-6 AWG				1" Maximum /14-4 AWG			
DC Input Conduit Size / # of Strings / AWG Range	1" Maximum / 1-2 strings / 14-6 AWG				1" Maximum / 1-3 strings / 14-6 AWG			
Dimensions with Safety Switch (HxWxD)	17.7 x 14.6 x 6.8 / 450 x 370 x 174				21.3 x 14.6 x 7.3 / 540 x 370 x 185			in / mm
Weight with Safety Switch	22 / 10	25.1 / 11.4	26.2 / 11.9	38.8 / 17.6			lb / kg	
Noise	< 25				<50			dBA
Cooling	Natural Convection							
Operating Temperature Range	-40 to +140 / -40 to +60 <sup>(4)</sup>							°F / °C
Protection Rating	NEMA 4X (Inverter with Safety Switch)							

<sup>(3)</sup> Revenue grade inverter P/N: SExxxxH-US000BNC4

<sup>(4)</sup> Full power up to at least 50°C / 122°F; for power de-rating information refer to: <https://www.solaredge.com/sites/default/files/se-temperature-derating-note-na.pdf>

---

# Power Optimizer

## Frame-Mounted

P370 / P401 / P404 / P500



# POWER OPTIMIZER

## Fast mount power optimizers with module-level optimization

- Specifically designed to work with SolarEdge inverters
- Quicker installation - Power optimizers can be mounted in advance saving installation time
- Up to 25% more energy
- Superior efficiency (99.5%)
- Mitigates all types of modules mismatch-loss, from manufacturing tolerance to partial shading
- Flexible system design for maximum space utilization
- Next generation maintenance with module level monitoring
- Module-level voltage shutdown for installer and firefighter safety

# / Power Optimizer

## Frame-Mounted

P370 / P401 / P404 / P500

OPTIMIZER MODEL (TYPICAL MODULE COMPATIBILITY)	P370 (FOR HIGH-POWER 60-CELL AND FOR 72-CELL MODULES)	P401 (FOR HIGH POWER 60/72-CELL MODULES)	P404 (FOR 60-CELL AND 72-CELL, SHORT STRINGS)	P500 (FOR 96-CELL MODULES)	
<b>INPUT</b>					
Rated Input DC Power <sup>(1)</sup>	370	400	405	500	W
Absolute Maximum Input Voltage (Voc at lowest temperature)	60		80		Vdc
MPPT Operating Range	8 - 60		12.5 - 80	8 - 80	Vdc
Maximum Short Circuit Current (Isc)	11	11.75	11	10.1	Adc
Maximum Efficiency	99.5				%
Weighted Efficiency	98.8				%
Overvoltage Category	II				
<b>OUTPUT DURING OPERATION (POWER OPTIMIZER CONNECTED TO OPERATING SOLAREEDGE INVERTER)</b>					
Maximum Output Current	15				Adc
Maximum Output Voltage	60		85	60	Vdc
<b>OUTPUT DURING STANDBY (POWER OPTIMIZER DISCONNECTED FROM SOLAREEDGE INVERTER OR SOLAREEDGE INVERTER OFF)</b>					
Safety Output Voltage per Power Optimizer	1 ± 0.1				Vdc
<b>STANDARD COMPLIANCE</b>					
EMC	FCC Part15 Class B, IEC61000-6-2, IEC61000-6-3				
Safety	IEC62109-1 (class II safety), UL1741				
RoHS	Yes				
Fire Safety	VDE-AR-E 2100-712:2013-05				
<b>INSTALLATION SPECIFICATIONS</b>					
Maximum Allowed System Voltage	1000				Vdc
Dimensions (W x L x H)	139 x 165 x 40 / 5.5 x 6.5 x 1.6	129 x 153 x 29.5 / 5.08 x 6.02 x 1.16	139 x 165 x 48 / 5.5 x 6.5 x 1.9		mm / in
Weight (including cables)	775 / 1.7	655 / 1.5	895 / 2.0	870 / 1.9	gr / lb
Input Connector	MC4 <sup>(2)</sup>				
Input Wire Length	0.16 / 0.52				m / ft
Output Connector	MC4				
Output Wire Length	1.2 / 3.9				m / ft
Operating Temperature Range <sup>(3)</sup>	-40 to +85 / -40 to +185				°C / °F
Protection Rating	IP68 / NEMA6P				
Relative Humidity	0 - 100				%

(1) Rated power of the module at STC will not exceed the optimizer "Rated Input DC Power". Modules with up to +5% Power tolerance are allowed

(2) For other connector types please contact SolarEdge

(3) For ambient temperature above +85°C / +185°F power de-rating is applied. Refer to Power Optimizers Temperature De-Rating Technical Note for more details

PV SYSTEM DESIGN USING A SOLAREEDGE INVERTER <sup>(4)</sup>		SINGLE PHASE HD-WAVE	SINGLE PHASE	THREE PHASE	THREE PHASE FOR 277/480V GRID	
Minimum String Length (Power Optimizers)	P370/ P401/ P500 <sup>(5)</sup>	8		16	18	
	P404	6		14 (13 with SE3K) <sup>(6)</sup>	14	
Maximum String Length (Power Optimizers)		25		50	50	
Maximum Nominal Power per String		5700 <sup>(7)</sup>	5250 <sup>(7)</sup>	11250 <sup>(8)</sup>	12750	W
Parallel Strings of Different Lengths or Orientations		Yes				

(4) It is not allowed to mix P404 with P370/P401/P500 in one string

(5) The P370/P401/P500 cannot be used with the SE3K three phase inverter (available in some countries; refer to Three Phase Inverter SE3K-SE10K datasheet)

(6) Exactly 10 when using SE3K-RW010BNN4

(7) If the inverters rated AC power ≤ maximum nominal power per string, then the maximum power per string will be able to reach up to the inverters maximum input DC power Refer to: <https://www.solaredge.com/sites/default/files/se-power-optimizer-single-string-design-application-note.pdf>

(8) For SE27.6K, SE55K, SE82.8K: It is allowed to install up to 13,500W per string when 3 strings are connected to the inverter and when the maximum power difference between the strings is up to 2,000W; inverter max DC power: 37,250W

