

October 11, 2021

Encōr Solar, LLC
3401 N. Thanksgiving Way, Ste 450
Lehi, UT 84043

RE: Engineering Services
Valentine Residence
290 Wynnridge Dr, Angier, NC
7.6 kW System
Solo Job #1542189

To Whom It May Concern,

We have reviewed the following information regarding the solar panel installation for this project. Alterations to these documents or plans shall not be made without direct written consent of the Engineer of Record.

A. Assumptions from Field Observation provided by Encōr Solar, LLC

The following structural design regarding the proposed alterations have been prepared from these assumptions. The verification of the field observations is the responsibility of the contractor. **Prior to commencement of work, the contractor shall verify the framing sizes, spacings, and spans noted in the sealed plans, calculations, and/or certification letter and notify the Engineer of Record of any discrepancies.**

	<u>Roof</u>
Roof Finish :	Asphalt Shingle
Roof Underlayment :	OSB
Roof Profile :	Gable
Roof Structural System :	Metal Plate Trusses
Truss Top Chord/Setup :	2 x 4 / Fink
Chord/Rafter Wood Grade :	Southern Pine #2 or better
Truss/Rafter Spacing :	24" o.c.
Roof Slope :	25 deg
Max Top Chord/Rafter Span :	6.88 ft
Bearing Wall Type :	Convl Lt-Frame Constr
Foundation :	Permanent Concrete
Stories :	Single

B. Building Design Criteria

Code :	2018 IRC (ASCE 7-16)	Risk Category :	II
Roof Live Load :	20 psf (0 psf at panels)	Occupancy Class :	R-3
Ground Snow Load :	15 psf	Roof Dead Load :	6.5 psf
Ult Wind Speed :	120 mph	PV Dead Load :	<u>3 psf</u>
Exposure Category :	C	Total Dead Load :	9.5 psf

C. Summary of Existing Structure Results

Roof

After review of the field observations and based on our calculations and in accordance with the applicable building codes and current industry standards, the existing roof structure supporting the proposed alterations consisting of the solar array has been determined to be:

- Adequate to support the additional imposed loads. **No structural upgrades are required.**

D. Solar Panel Support Bracket Anchorage

- 1. Solar panels shall be designed, mounted, and installed in accordance with the most recent "SnapNrack Manual", which can be found on the SnapNrack website (<http://snapnrack.com/>).
- 2. Manufacturer's Panel Bracket Connection to Roof Chord/Rafter Member:

Fastener : (1) 5/16" Lag Screw per Bracket
 NDS Withdrawl Value : 307 lbs/inch
 Min. Thread Length and Penetration Depth : 2.5"

- 3. Considering the existing roof's slope, size, spacing, condition, and calculated loads, the panel bracket supports shall be placed no greater than 72 in. o/c.
- 4. Panel supports connections shall be staggered to distribute load to adjacent trusses.

E. Overall Summary

Based on the information supplied to us at the time of this report, on the evaluation of the existing structure, and solar array panel bracket connection, it is our opinion that the roof system will adequately support the additional loads imposed by the solar array. This evaluation conforms to 2018 IRC and current industry standards.

Should you have any questions regarding this letter or if you require further information, do not hesitate to contact me.

Sincerely,

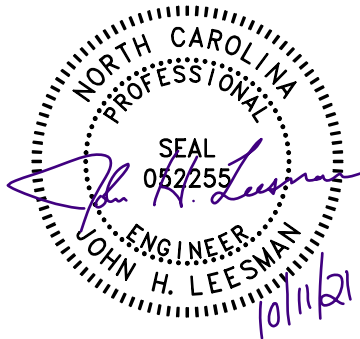

John H. Leesman, PE
License No. 52255

Limits of Scope of Work and Liability

The existing structure is assumed to have been designed and constructed following appropriate codes at the time of erection and assumed to have appropriated permits. The calculations performed are only for the roof framing supporting the solar array installation referenced in the stamped plans and were completed according to generally recognized structural analysis standards and procedures, professional engineering, and design experience opinions and judgements. Existing deficiencies which are unknown or were not observed during the time the site observation are not included in this scope of work. All solar panel modules, racking, and mounting equipment shall be designed and installed per the manufacturer's approved installation specifications. The Engineer of Record and the engineering consulting firm assume no responsibility for misuse or improper installation. This analysis is not stamped for water leakage. Framing was determined on information in provided plans and/or photos, along with engineering judgement. Prior to commencement of work, the contractor shall verify the framing sizes, spacings, and spans noted in the stamped plans, calculations, and/or certification letter and notify the Engineer of Record of any discrepancies prior to starting construction. If during solar panel installation, the roof framing members appear unstable or deflect non-uniformly, our office should be notified before proceeding with the installation. The contractor shall also verify that there are no damage/deficiencies (i.e., dry rot, water damage, termite damage, framing member/connection damage, etc.) to framing that was not addressed in the stamped plans, calculations, and/or certification letter and notify the Engineer of Record of any concerns prior to starting construction.

AERIAL VIEW:



STREET VIEW:



CONTRACTOR INFORMATION:

PALMETTO
1505 King Street
EXT Ste 114
Charleston SC, 29405

SITE INFORMATION

Brian Valentine
290 Wynnridge Dr
Angier, NC 27501
AC SYSTEM SIZE: 7.6 kW AC
DC SYSTEM SIZE: 8.8 kW DC
Lat, 35.4655943
Long, -78.6890824
(22) Hanwha Q.PEAK DUO BLK ML-G10+
400 PV MODULES
(1) SolarEdge SE7600H-US (240V)
INVERTER(S)
Duke Energy Progress

GENERAL NOTES

1. INSTALLATION OF SOLAR PHOTOVOLTAIC SYSTEM SHALL BE IN ACCORDANCE WITH NEC ARTICLE 690, AND ALL OTHER APPLICABLE NEC CODES WHERE NOTED OR EXISTING.
2. PROPER ACCESS AND WORKING CLEARANCE AROUND EXISTING AND PROPOSED ELECTRICAL EQUIPMENT WILL COMPLY WITH NEC ARTICLE 110.
3. ALL WIRES, INCLUDING THE GROUNDING ELECTRODE CONDUCTOR SHALL BE PROTECTED FROM PHYSICAL DAMAGE IN ACCORDANCE WITH NEC ARTICLE 250
4. THE PV MODULES ARE CONSIDERED NON-COMBUSTIBLE; THIS SYSTEM IS UTILITY INTERACTIVE PER UL 1741 AND DOES NOT INCLUDE STORAGE BATTERIES OR OTHER ALTERNATIVE STORAGE SOURCES.
5. ALL DC WIRES SHALL BE SIZED ACCORDING TO [NEC 690.8]
6. DC CONDUCTORS SHALL BE WITHIN PROTECTED RACEWAYS IN ACCORDANCE WITH [NEC 690.31]
7. ALL SIGNAGE TO BE PLACED IN ACCORDANCE WITH LOCAL JURISDICTIONAL BUILDING CODE.

PHOTOVOLTAIC (PV) SYSTEM SPECIFICATIONS

EQUIPMENT:
AC SYSTEM SIZE: 7.6 kW AC
DC SYSTEM SIZE: 8.8 kW DC
(22) Hanwha Q.PEAK DUO BLK ML-G10+ 400 PV MODULES
(1) SolarEdge SE7600H-US (240V) INVERTER(S)
RACKING: SnapNrack - 72" O.C.

APPLICABLE GOVERNING CODES

- 2017 NEC
- 2018 IRC
- 2018 IFC
- 2018 IBC
- 2018 NC RBC

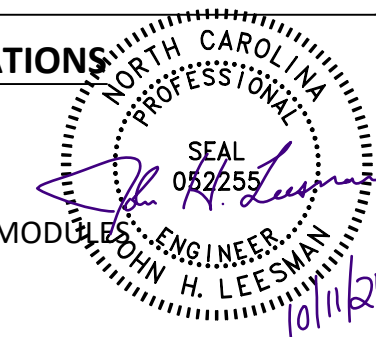

SITE SPECIFICATIONS

OCCUPANCY: R-3
ZONING: RESIDENTIAL

SHEET INDEX:

- PV01 COVER PAGE
- PV02 SITE PLAN
- PV03 ROOF ATTACHMENTS
- PV04 MOUNTING DETAIL
- PV05 LINE DIAGRAM
- PV06 LABELS
- PV07 PLACARD
- PV08 SITE PHOTOS

DRAWN BY: SoloCAD

DATE:
October 9, 2021

COVER PAGE - PV01

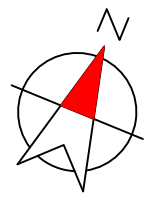

CLOSE UP OF HOME

FRONT OF HOME

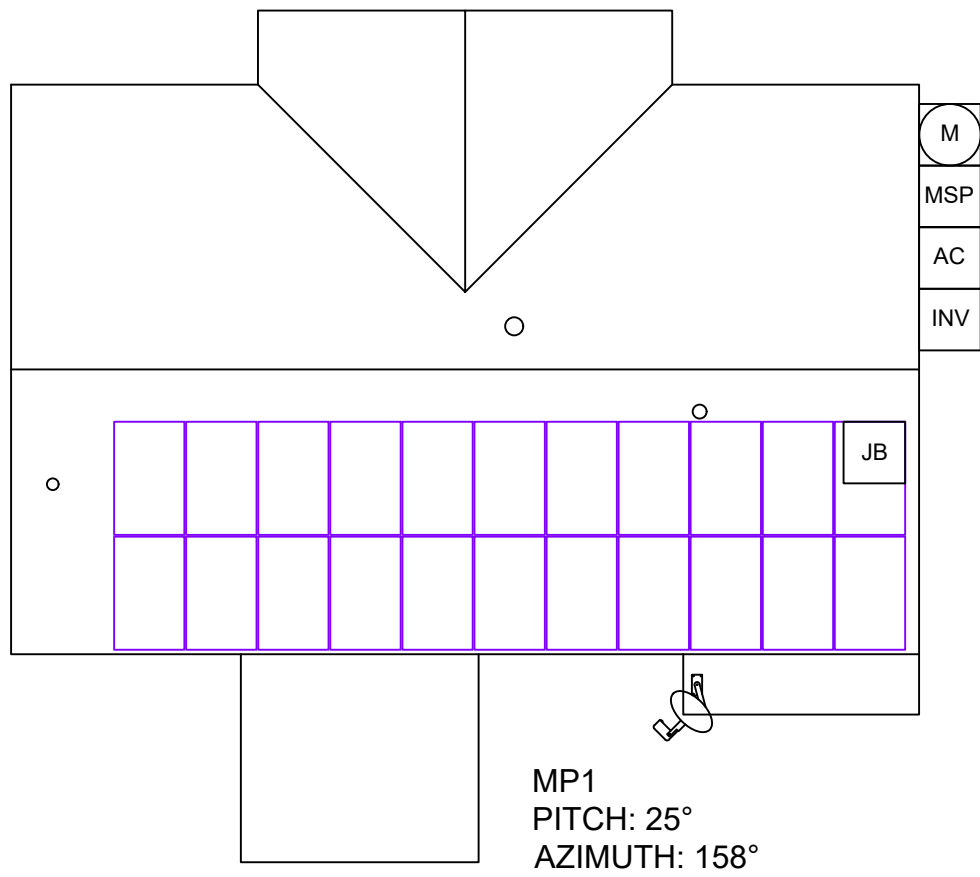

MP1
PITCH: 25°
AZIMUTH: 158°

290 Wynnridge Dr

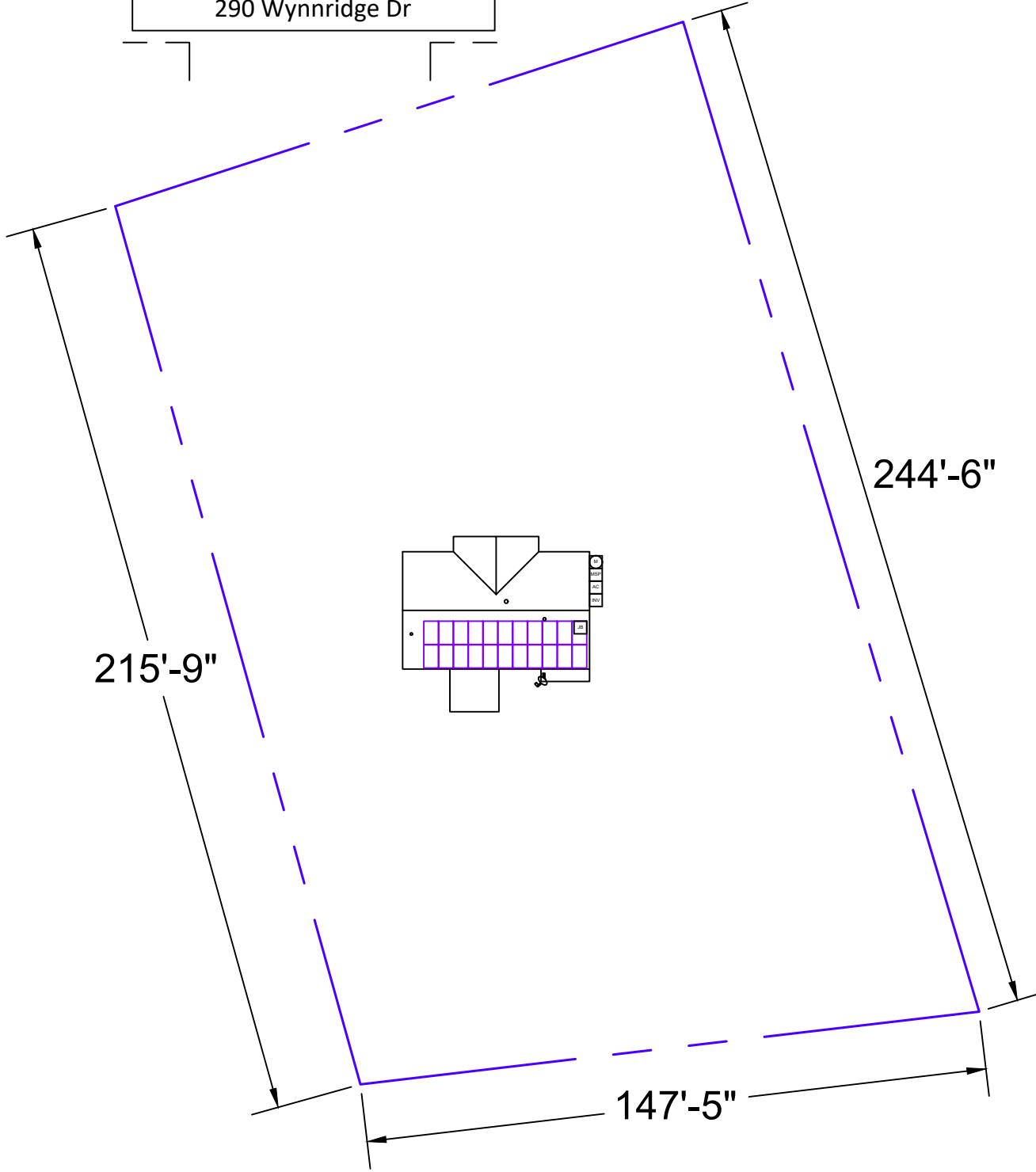

CONTRACTOR INFORMATION:

PALMETTO
1505 King Street
EXT Ste 114
Charleston SC, 29405

SITE INFORMATION

Brian Valentine
290 Wynnridge Dr
Angier, NC 27501
AC SYSTEM SIZE: 7.6 kW AC
DC SYSTEM SIZE: 8.8 kW DC
Lat, 35.4655943
Long, -78.6890824
(22) Hanwha Q.PEAK DUO BLK ML-G10+
400 PV MODULES
(1) SolarEdge SE7600H-US (240V)
INVERTER(S)
Duke Energy Progress

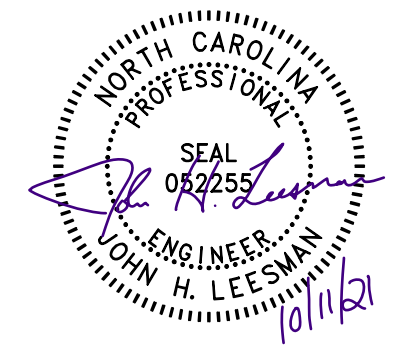

EQUIPMENT LEGEND:

- | | | | | | |
|--------------------|--|--------------|-------------|------------------------------|--------------|
| UTILITY METER | VISIBLE, LOCKABLE, LABELED AC DISCONNECT | INVERTER | SUB PANEL | FIRE ACCESS PATHWAY (3' TYP) | BATTERY(IES) |
| MAIN SERVICE PANEL | METER SOCKET (FOR UTILITY PV METER) | COMBINER BOX | LOAD CENTER | PROPERTY LINE | |

VISIBLE, LOCKABLE, LABELED AC DISCONNECT LOCATED WITHIN 10' OF UTILITY METER

DRAWN BY: SoloCAD

DATE:
October 9, 2021

SITE PLAN - PV02

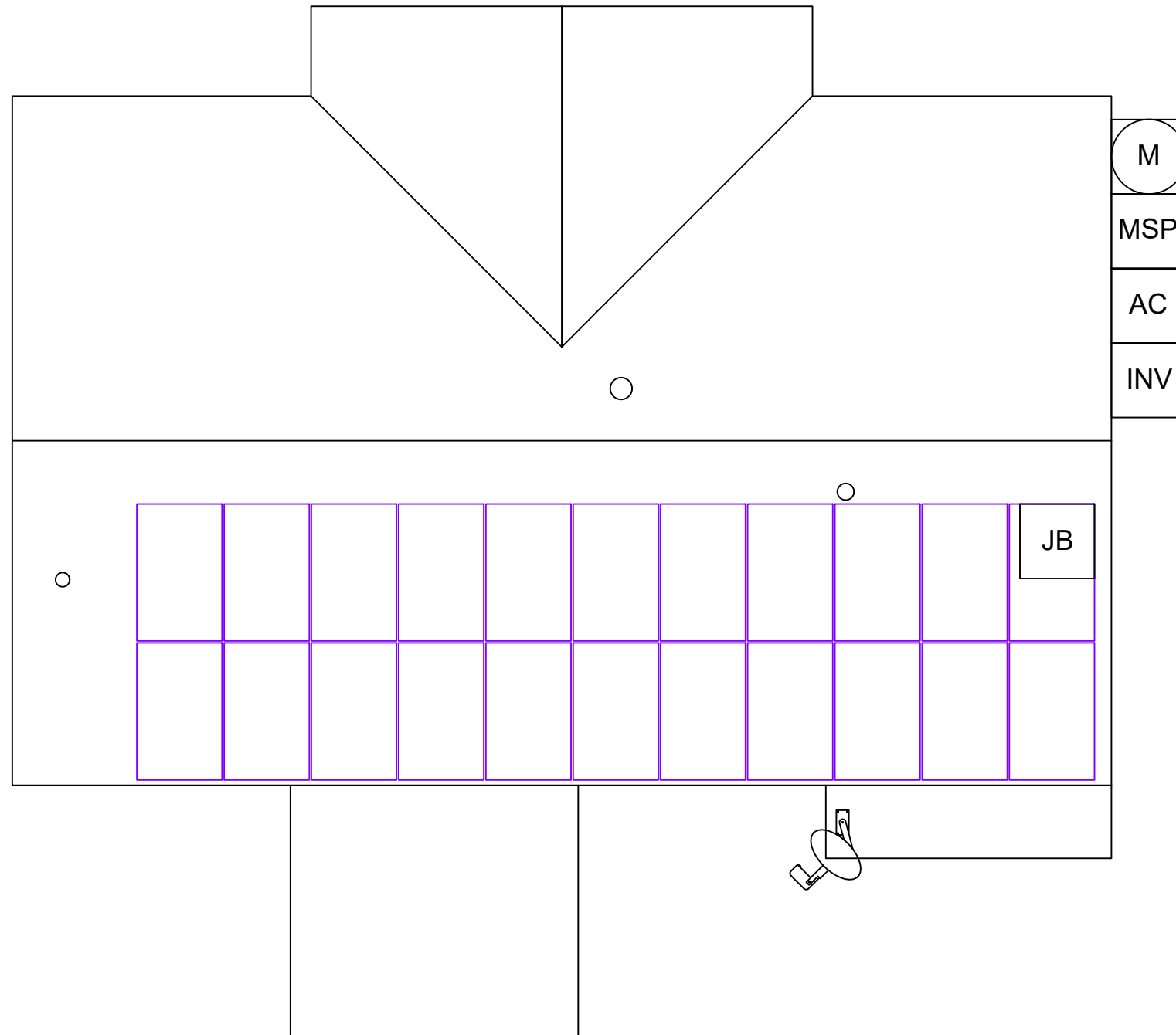

CONTRACTOR INFORMATION:

PALMETTO
 1505 King Street
 EXT Ste 114
 Charleston SC, 29405

SITE INFORMATION

Brian Valentine
 290 Wynnridge Dr
 Angier, NC 27501
 AC SYSTEM SIZE: 7.6 kW AC
 DC SYSTEM SIZE: 8.8 kW DC
 Lat, 35.4655943
 Long, -78.6890824
 (22) Hanwha Q.PEAK DUO BLK ML-G10+
 400 PV MODULES
 (1) SolarEdge SE7600H-US (240V)
 INVERTER(S)
 Duke Energy Progress



DRAWN BY: SoloCAD

DATE:
 October 9, 2021

ROOF ATTACHMENTS - PV03

EQUIPMENT INFORMATION:		ROOF INFO:		PHOTOVOLTAIC ARRAY STRUCTURAL CRITERIA:	
RAIL MANUFACTURER	SnapNrack	ROOF TYPE	asphalt_shingle	PV MODULE COUNT:	22
RAIL PART NUMBER	Standard Rail	ROOF FRAMING	traditional_framing	ARRAY AREA:	MODULE COUNT * 18.06ft ² = 397.32
ATTACHMENTS	SnapNrack 100 Series	RAFTER/TOP CHORD SIZE	2x4	ROOF AREA:	1381.4 ft ²
ATTACHMENT QTY	28	RAFTER/TOP CHORD SPACING	24"	PERCENT OF ROOF COVERED:	29%
SPLICE QTY	12	ATTACHMENT SPACING	72	ARRAY WEIGHT:	MODULE COUNT * 50lbs = 1100
MIDCLAMP QTY	40			DISTRIBUTED LOAD:	ARRAY LBS/ATTACHMENTS = 39.29
ENDCLAMP QTY	8			POINT LOAD: (lbs/ft ²)	(ARRAY) WEIGHT/AREA = 2.77 lbs/ft ²

DESCRIPTION:
SNAPNRACK, ULTRA RAIL COMP KIT

PART NUMBER(S):
SEE BELOW

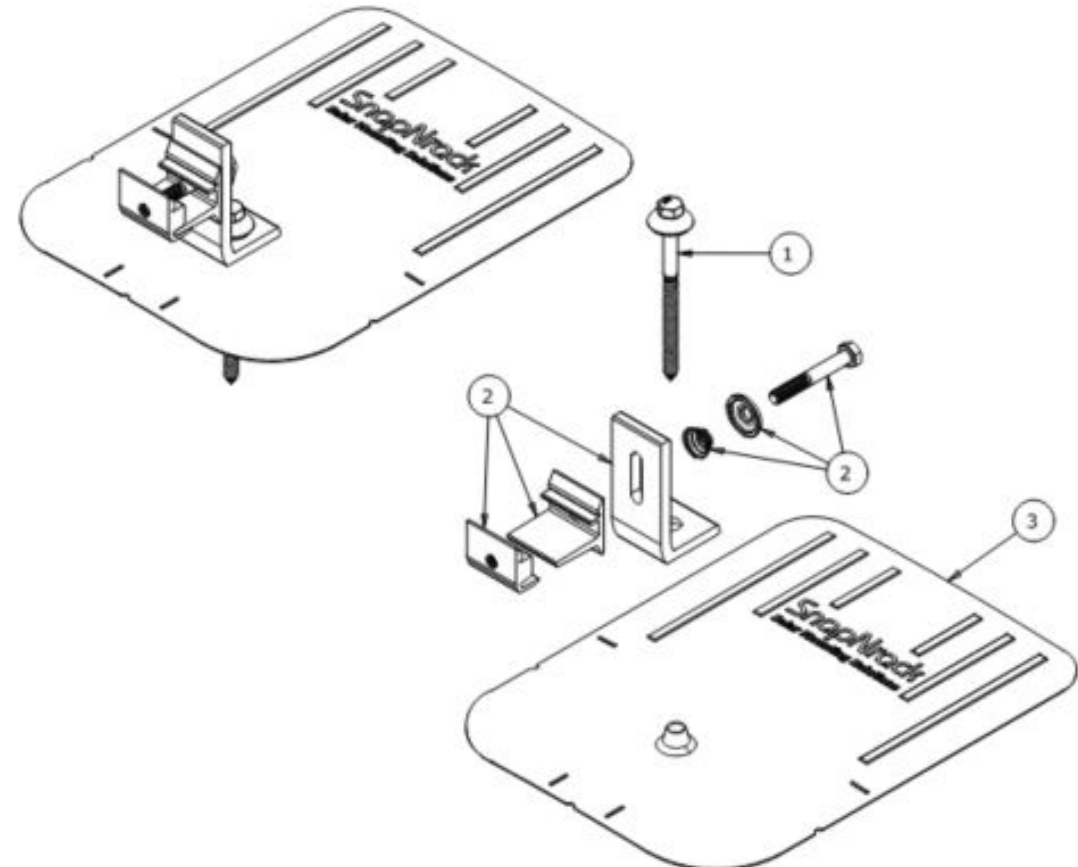

PARTS LIST			
ITE	QTY	PART NUMBER	DESCRIPTION
1	1	242-92266	SNAPNRACK, UMBRELLA LAG, TYPE 3, 4IN, SS
2	1	242-01219, 242-01220	SNAPNRACK, ULTRA FOOT FOR U FLASHING, SILVER / BLACK
3	1	232-01375, 232-01376	SNAPNRACK, COMP FLASHING, 9IN X 12IN, SILVER / BLACK ALUM

MATERIALS:	6000 SERIES ALUMINUM, STAINLESS STEEL, RUBBER
DESIGN LOAD (LBS):	405 UP, 788 DOWN, 236 SIDE
ULTIMATE LOAD (LBS):	2006 UP, 4000 DOWN, 1070 SIDE
TORQUE SPECIFICATION:	12 LB-FT
CERTIFICATION:	UL 2703, FILE E359313
WEIGHT (LBS):	0.80

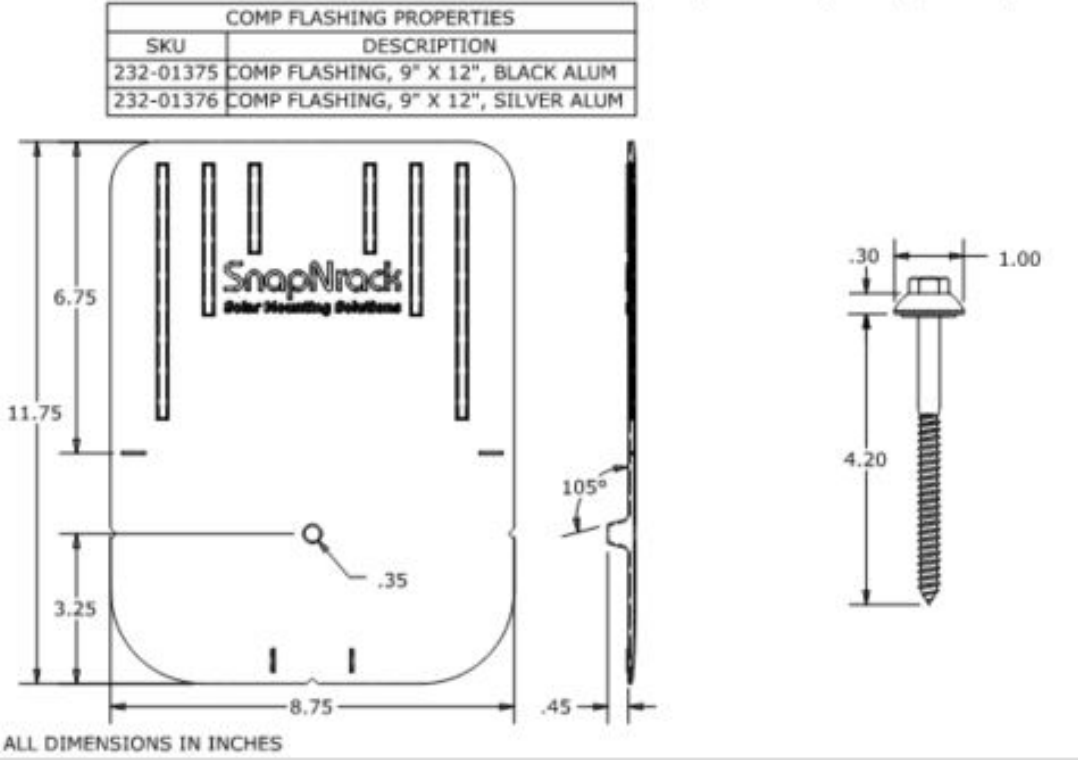
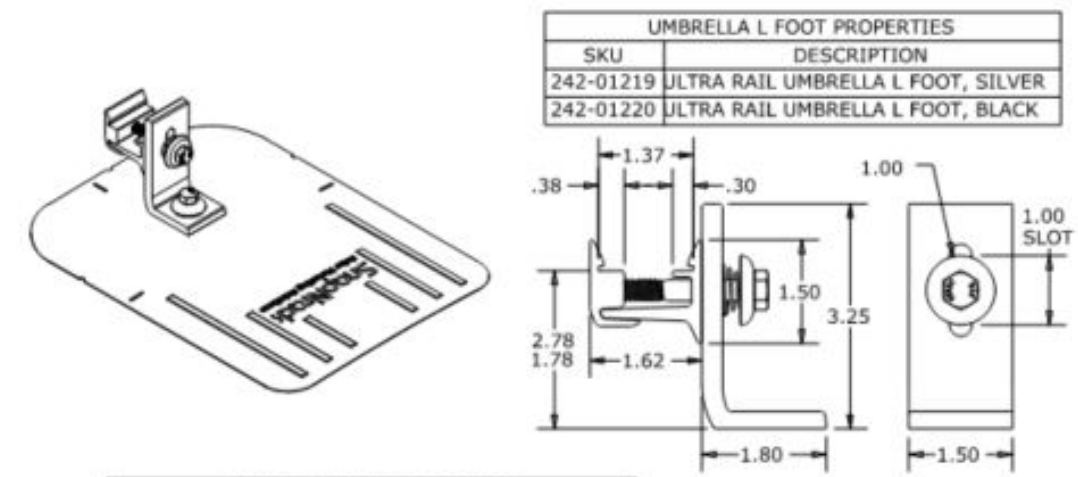

CONTRACTOR INFORMATION:
PALMETTO
1505 King Street
EXT Ste 114
Charleston SC, 29405

SITE INFORMATION

Brian Valentine
290 Wynnridge Dr
Angier, NC 27501
AC SYSTEM SIZE: 7.6 kW AC
DC SYSTEM SIZE: 8.8 kW DC
Lat, 35.4655943
Long, -78.6890824
(22) Hanwha Q.PEAK DUO BLK ML-G10+
400 PV MODULES
(1) SolarEdge SE7600H-US (240V)
INVERTER(S)
Duke Energy Progress



EQUIPMENT INFORMATION:		ROOF INFO:		PHOTOVOLTAIC ARRAY STRUCTURAL CRITERIA:	
RAIL MANUFACTURER	SnapNrack	ROOF TYPE	asphalt_shingle	PV MODULE COUNT:	22
RAIL PART NUMBER	Standard Rail	ROOF FRAMING	traditional_framing	ARRAY AREA:	MODULE COUNT * 18.06ft ² = 397.32
ATTACHMENTS	SnapNrack 100 Series	RAFTER/TOP CHORD SIZE	2x4	ROOF AREA:	1381.4 ft ²
ATTACHMENT QTY	28	RAFTER/TOP CHORD SPACING	24"	PERCENT OF ROOF COVERED:	29%
SPLICE QTY	12	ATTACHMENT SPACING	72	ARRAY WEIGHT:	MODULE COUNT * 50lbs = 1100
MIDCLAMP QTY	40			DISTRIBUTED LOAD:	ARRAY LBS/ATTACHMENTS = 39.29
ENDCLAMP QTY	8			POINT LOAD: (lbs/ft ²)	(ARRAY) WEIGHT/AREA = 2.77 lbs/ft ²

DRAWN BY: SoloCAD

DATE:
October 9, 2021

MOUNTING DETAIL - PV04

EQUIPMENT SCHEDULE:

TYPE:	QTY:	DESCRIPTION:	RATING:
MODULES:	(22)	Hanwha Q.PEAK DUO BLK ML-G10+ 400	400 W
INVERTERS:	(1)	SolarEdge SE7600H-US (240V)	7600 W
AC DISCONNECT(S):	(1)	PV AC DISCONNECT, 240V, 2-POLE	60A
DC OPTIMIZERS:	(22)	SolarEdge P400	15 Adc

Conduit & Conductor Schedule

TAG	WIRE GAUGE	DESCRIPTION	QTY	CONDUIT SIZE	CONDUCTOR RATING	# OF CONDUCTORS DERATE	TEMP. DERATE	CONDUCTOR RATING W/DERATES	CONDUIT FILL
1	10 AWG	PV-WIRE , USE-2, COPPER (L 1, L 2)	(2)	N/A - FREE AIR	40A	N/A - FREE AIR	0.91	36.4A	N/A - FREE AIR
	6 AWG	BARE, COPPER (GROUND)	(1)						
2	10 AWG	THWN-2, or THHN, or 10/2 NM-B COPPER - (L 1, L 2)	(2)	3/4" EMT	40A	1	0.91	36.4A	11.9%
	10 AWG	THWN-2, or THHN, or 10/2 NM-B COPPER - (GROUND)	(1)						
3	10 AWG	THHN/THWN-2, COPPER - (L1, L2)	(4)	3/4" EMT	40A	0.8	0.91	29.12A	19.8%
	10 AWG	THHN/THWN-2 - (GROUND)	(1)						
4	8 AWG	THWN-2 COPPER - (L1, L2, NEUTRAL)	(3)	3/4" EMT	50A	1	0.91	45.5A	24.6%
	10 AWG	THWN-2 COPPER - (GROUND)	(1)						

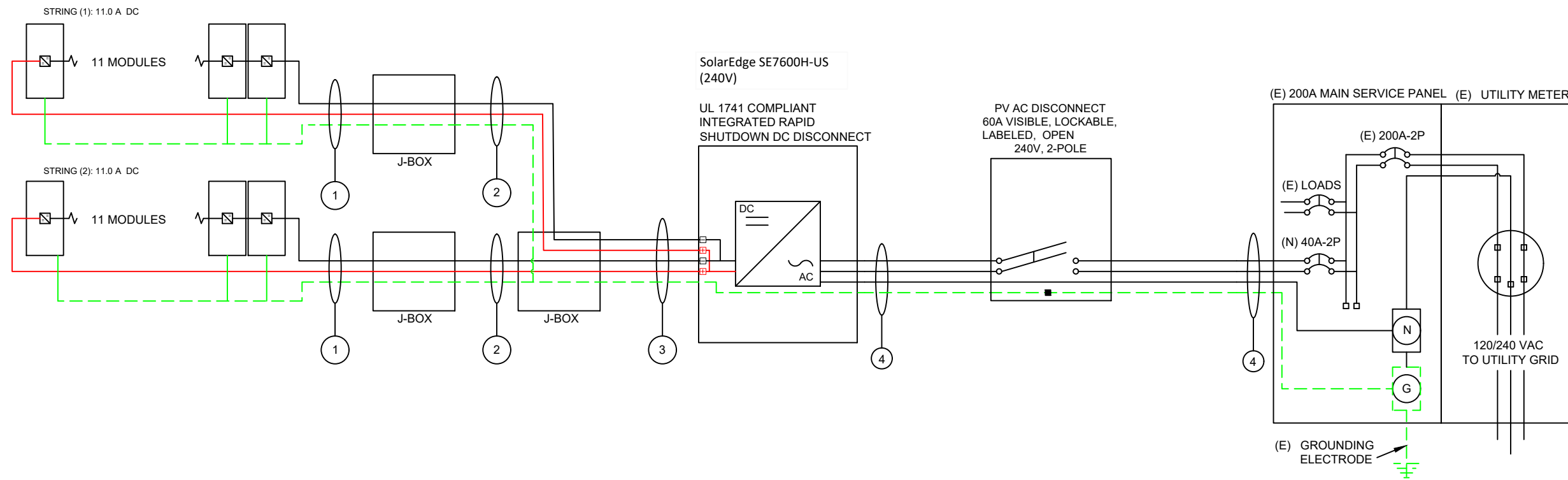

GROUNDING & GENERAL NOTES:

- PV INVERTER IS UNGROUNDED, TRANSFORMER-LESS TYPE.
- DC GEC AND AC EGC TO REMAIN UNSPLICED, OR SPLICED TO EXISTING ELECTRODE
- ANY EXISTING WIRING INVOLVED WITH PV SYSTEM CONNECTION THAT IS FOUND TO BE INADEQUATE PER CODE SHALL BE CORRECTED PRIOR TO FINAL INSPECTION.
- JUNCTION BOX QUANTITIES, AND PLACEMENT SUBJECT TO CHANGE IN THE FIELD - JUNCTION BOXES DEPICTED ON ELECTRICAL DIAGRAM REPRESENT WIRE TYPE TRANSITIONS.
- AC DISCONNECT NOTED IN EQUIPMENT SCHEDULE OPTIONAL IF OTHER AC DISCONNECTING MEANS IS LOCATED WITHIN 10' OF SERVICE DISCONNECT.

INTERCONNECTION NOTES:

- INTERCONNECTION SIZING, LIMITATIONS AND COMPLIANCE DETERMINED IN ACCORDANCE WITH [NEC 705.12], AND [NEC 690.64].
- GROUND FAULT PROTECTION IN ACCORDANCE WITH [NEC 215.9], [NEC 230.95] AND [NEC 690.5]
- ALL EQUIPMENT TO BE RATED FOR BACKFEEDING.
- PV BREAKER TO BE POSITIONED AT THE OPPOSITE END OF THE BUSBAR RELATIVE TO THE MAIN BREAKER.

DISCONNECT NOTES

- DISCONNECTING SWITCHES SHALL BE WIRED SUCH THAT WHEN THE SWITCH IS OPENED THE CONDUCTORS REMAINING LIVE ARE CONNECTED TO THE TERMINALS MARKED "LINE SIDE" (TYPICALLY THE UPPER TERMINALS)
- AC DISCONNECT MUST BE ACCESSIBLE TO QUALIFIED UTILITY PERSONNEL, BE LOCKABLE, AND BE A VISIBLE-BREAK SWITCH

VISIBLE, LOCKABLE, LABELED AC DISCONNECT LOCATED WITHIN 10' OF UTILITY METER

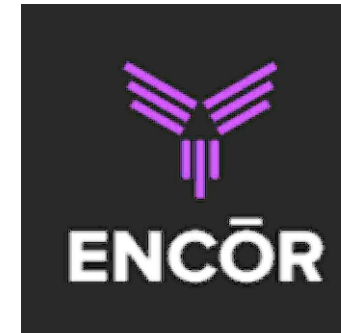

CONTRACTOR INFORMATION:

PALMETTO
1505 King Street
EXT Ste 114
Charleston SC, 29405

SITE INFORMATION

Brian Valentine

290 Wynnridge Dr
Angier, NC 27501

AC SYSTEM SIZE: 7.6 kW AC

DC SYSTEM SIZE: 8.8 kW DC

Lat, 35.4655943

Long, -78.6890824

(22) Hanwha Q.PEAK DUO BLK ML-G10+ 400 PV MODULES

(1) SolarEdge SE7600H-US (240V) INVERTER(S)

Duke Energy Progress

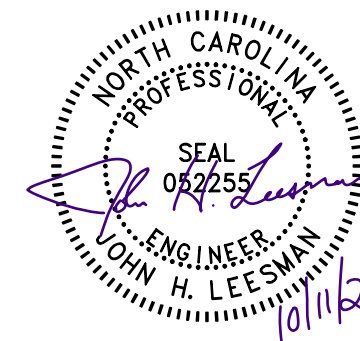

DRAWN BY: SoloCAD

DATE:
October 9, 2021

LINE DIAGRAM - PV05

WARNING
ELECTRIC SHOCK HAZARD
TERMINALS ON THE LINE AND
LOAD SIDES MAY BE ENERGIZED
IN THE OPEN POSITION

LABEL 1
FOR PV DISCONNECTING MEANS WHERE THE LINE AND
LOAD TERMINALS MAY BE ENERGIZED IN THE OPEN
POSITION.
[NEC 690.13(B)]

WARNING
THIS EQUIPMENT IS FED BY MULTIPLE
SOURCES. TOTAL RATING OF ALL
OVERCURRENT DEVICES, EXCLUDING
MAIN SUPPLY OVERCURRENT
DEVICE, SHALL NOT EXCEED
AMPACITY OF BUSBAR.

LABEL 2
PLACED ADJACENT TO THE BACK-FED BREAKER
FROM THE INVERTER IF TIE IN CONSISTS OF
LOAD SIDE CONNECTION TO BUSBAR.
[NEC 705.12(B)(2)(3)(b)]

WARNING
INVERTER OUTPUT CONNECTION
DO NOT RELOCATE
THIS OVERCURRENT
DEVICE

LABEL 3
PLACED ADJACENT TO THE BACK-FED BREAKER
FROM THE INVERTER IF TIE IN CONSISTS OF
LOAD SIDE CONNECTION TO BUSBAR.
[NEC 705.12(B)(2)(3)(c)]

WARNING
DUAL POWER SUPPLY
SOURCES: UTILITY GRID AND PV
SOLAR ELECTRIC SYSTEM

LABEL 4
EQUIPMENT CONTAINING OVERCURRENT
DEVICES IN CIRCUITS SUPPLYING POWER
TO A BUSBAR OR CONDUCTOR SUPPLIED
FROM MULTIPLE SOURCES SHALL BE
MARKED TO INDICATE THE PRESENCE OF
ALL SOURCES [NEC 705.12(B)(3)]

PHOTOVOLTAIC AC DISCONNECT
RATED AC OUTPUT CURRENT: 32
NOMINAL OPERATING AC VOLTAGE: 240

LABEL 5
AT POINT OF INTERCONNECTION, MARKED
AT AC DISCONNECTING MEANS.
[NEC 690.54, NEC 690.13 (B)]

LABELING NOTES:

1. LABELS CALLED OUT ACCORDING TO ALL COMMON CONFIGURATIONS. ELECTRICIAN TO DETERMINE EXACT REQUIREMENTS IN THE FIELD PER CURRENT NEC AND LOCAL CODES AND MAKE APPROPRIATE ADJUSTMENTS.
2. LABELING REQUIREMENTS BASED ON THE 2017 NATIONAL ELECTRIC CODE, OSHA STANDARD 19010.145, ANSI Z535.
3. MATERIAL BASED ON THE REQUIREMENTS OF THE AUTHORITY HAVING JURISDICTION.
4. LABELS TO BE OF SUFFICIENT DURABILITY TO WITHSTAND THE ENVIRONMENT INVOLVED [NEC 110.21(B)(3)]
5. LABELS TO BE A MINIMUM LETTER HEIGHT OF 3/8", WHITE ON RED BACKGROUND; REFLECTIVE, AND PERMANENTLY AFFIXED [IFC 605.11.1.1]

**WARNING: PHOTOVOLTAIC
POWER SOURCE**

LABEL 6
AT DIRECT-CURRENT EXPOSED RACEWAYS, CABLE TRAYS, COVERS
AND ENCLOSURES OF JUNCTION BOXES, AND OTHER WIRING METHODS;
SPACED AT MAXIMUM 10FT SECTION OR WHERE SEPARATED BY
ENCLOSURES, WALLS, PARTITIONS, CEILINGS, OR FLOORS.
[NEC 690.31(G)(3&4)]

**SOLAR PV SYSTEM EQUIPPED
WITH RAPID SHUTDOWN**

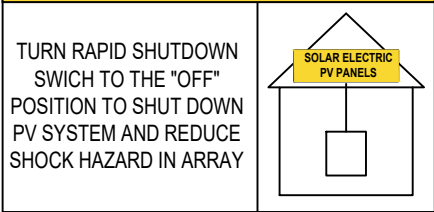

LABEL 7
FOR PV SYSTEMS THAT SHUT DOWN THE ARRAY AND CONDUCTORS
LEAVING THE ARRAY:
SIGN TO BE LOCATED ON OR NO MORE THAN 3 FT AWAY FROM SERVICE
DISCONNECTING MEANS TO WHICH THE PV SYSTEMS ARE CONNECTED
AND SHALL INDICATE THE LOCATION OF ALL IDENTIFIED RAPID
SHUTDOWN SWITCHES IF NOT AT THE SAME LOCATION.
[NEC 690.56(C)(1)(A)]

**SOLAR PV SYSTEM EQUIPPED
WITH RAPID SHUTDOWN**

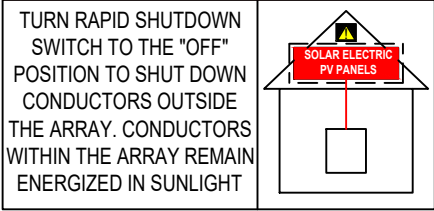

LABEL 8
FOR PV SYSTEMS THAT ONLY SHUT DOWN
CONDUCTORS LEAVING THE ARRAY:
SIGN TO BE LOCATED ON OR NO MORE THAN 3 FT
AWAY FROM SERVICE DISCONNECTING MEANS TO
WHICH THE PV SYSTEMS ARE CONNECTED AND
SHALL INDICATE THE LOCATION OF ALL IDENTIFIED
RAPID SHUTDOWN SWITCHES IF NOT AT THE SAME
LOCATION.
[NEC 690.56(C)(1)(b)]

**RAPID SHUTDOWN
SWITCH FOR
SOLAR PV SYSTEM**

LABEL 9
SIGN LOCATED AT RAPID SHUT DOWN
DISCONNECT SWITCH [NEC 690.56(C)(3)].

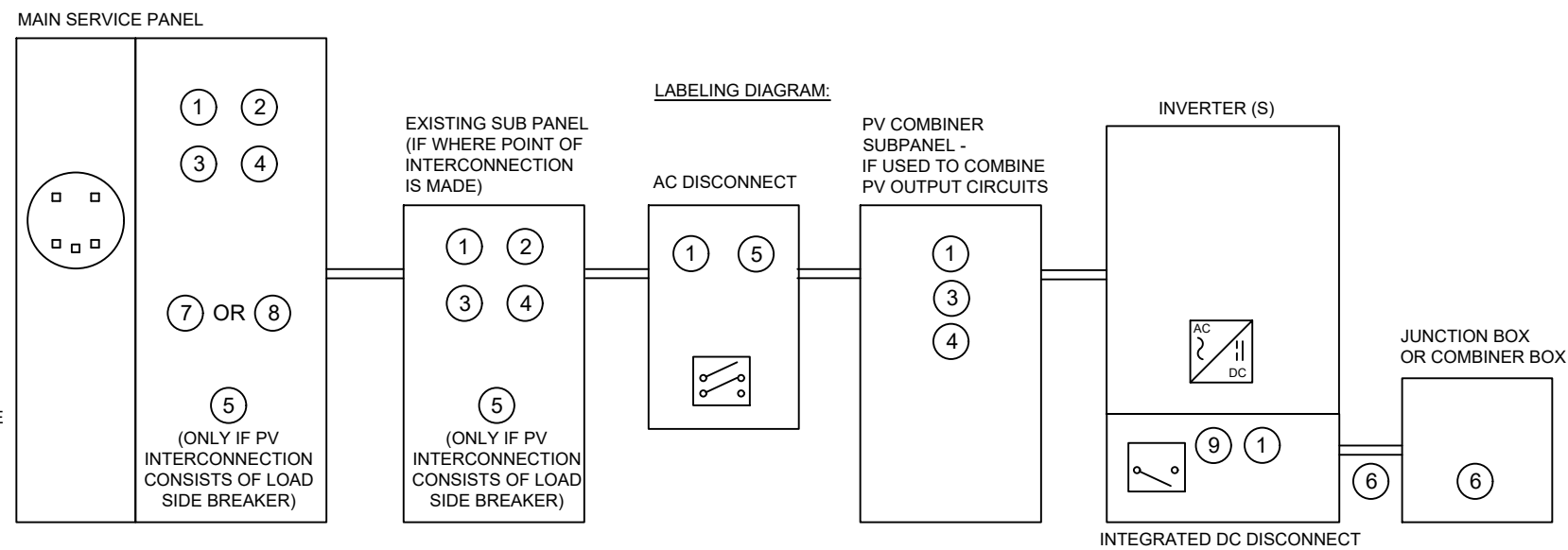

*ELECTRICAL DIAGRAM SHOWN ABOVE IS FOR LABELING PURPOSES ONLY. NOT AN ACTUAL REPRESENTATION OF EQUIPMENT AND CONNECTIONS TO BE INSTALLED. LABEL LOCATIONS PRESENTED MAY VARY DEPENDING ON TYPE OF INTERCONNECTION METHOD AND LOCATION PRESENTED ON THE ELECTRICAL DIAGRAM PAGE.



CONTRACTOR INFORMATION:

PALMETTO
1505 King Street
EXT Ste 114
Charleston SC, 29405

SITE INFORMATION

Brian Valentine
290 Wynnridge Dr
Angier, NC 27501
AC SYSTEM SIZE: 7.6 kW AC
DC SYSTEM SIZE: 8.8 kW DC
Lat, 35.4655943
Long, -78.6890824
(22) Hanwha Q.PEAK DUO BLK ML-G10+
400 PV MODULES
(1) SolarEdge SE7600H-US (240V)
INVERTER(S)
Duke Energy Progress

DRAWN BY: SoloCAD

DATE:
October 9, 2021

LABELS - PV06

CAUTION

POWER TO THIS BUILDING IS ALSO SUPPLIED FROM ROOF MOUNTED SOLAR ARRAYS WITH SAFETY DISCONNECTS AS SHOWN:

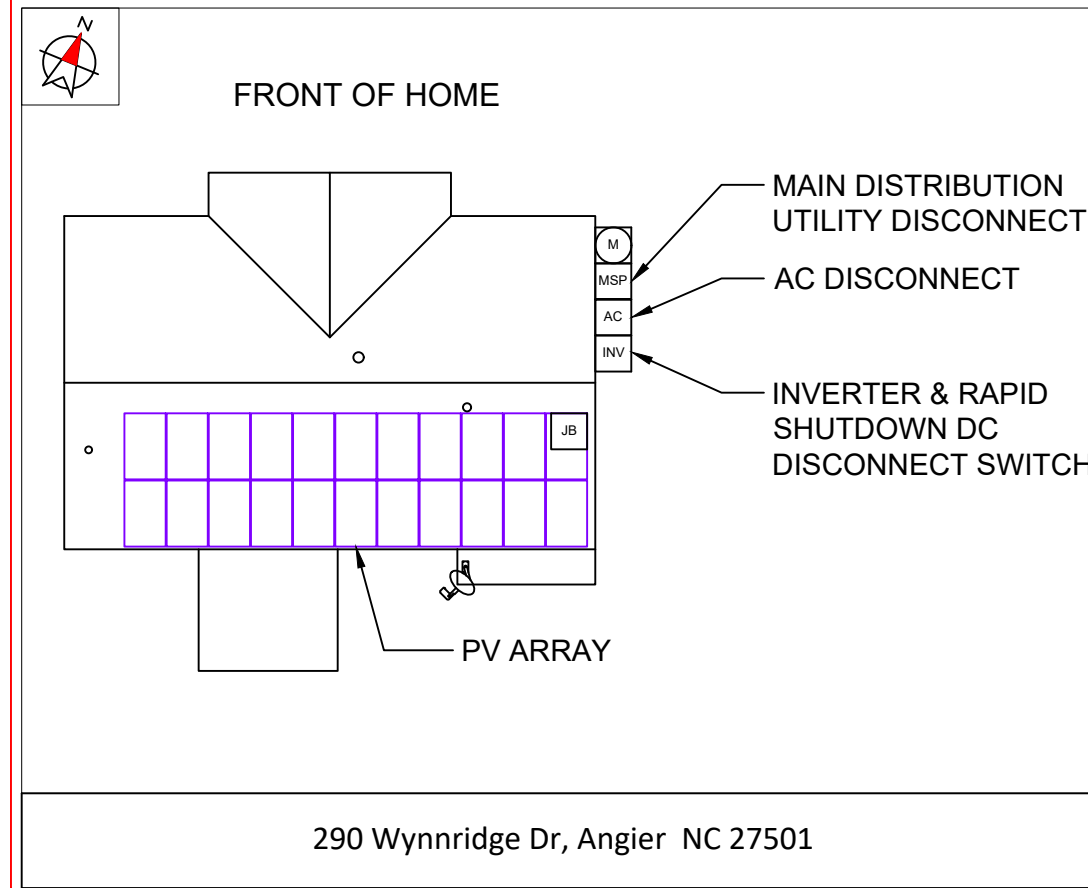

DIRECTORY

PERMANENT PLAQUE OR DIRECTORY PROVIDING THE LOCATION OF THE SERVICE DISCONNECTING MEANS AND THE PHOTOVOLTAIC SYSTEM.

(ALL PLAQUES AND SIGNAGE WILL BE INSTALLED AS OUTLINED WITHIN:
NEC 690.56(B)&(C), [NEC 705.10])



CONTRACTOR INFORMATION:

PALMETTO
1505 King Street
EXT Ste 114
Charleston SC, 29405

SITE INFORMATION

Brian Valentine

290 Wynnridge Dr
Angier, NC 27501

AC SYSTEM SIZE: 7.6 kW AC

DC SYSTEM SIZE: 8.8 kW DC

Lat, 35.4655943

Long, -78.6890824

(22) Hanwha Q.PEAK DUO BLK ML-G10+
400 PV MODULES

(1) SolarEdge SE7600H-US (240V)
INVERTER(S)

Duke Energy Progress

DRAWN BY: SoloCAD

DATE:
October 9, 2021

PLACARD - PV07

SITE PHOTOS:



CONTRACTOR INFORMATION:

PALMETTO
1505 King Street
EXT Ste 114
Charleston SC, 29405

SITE INFORMATION

Brian Valentine

290 Wynnridge Dr
Angier, NC 27501

AC SYSTEM SIZE: 7.6 kW AC

DC SYSTEM SIZE: 8.8 kW DC

Lat, 35.4655943

Long, -78.6890824

(22) Hanwha Q.PEAK DUO BLK ML-G10+
400 PV MODULES

(1) SolarEdge SE7600H-US (240V)
INVERTER(S)

Duke Energy Progress

DRAWN BY: SoloCAD

DATE:
October 9, 2021

SITE PHOTOS - PV08

powered by
Q.ANTUM DUO Z



Q.PEAK DUO BLK ML-G10+

385-405

ENDURING HIGH PERFORMANCE



BREAKING THE 20% EFFICIENCY BARRIER

Q.ANTUM DUO Z Technology with zero gap cell layout boosts module efficiency up to 20.9%.



THE MOST THOROUGH TESTING PROGRAMME IN THE INDUSTRY

Q CELLS is the first solar module manufacturer to pass the most comprehensive quality programme in the industry: The new "Quality Controlled PV" of the independent certification institute TÜV Rheinland.



INNOVATIVE ALL-WEATHER TECHNOLOGY

Optimal yields, whatever the weather with excellent low-light and temperature behavior.



ENDURING HIGH PERFORMANCE

Long-term yield security with Anti LID Technology, Anti PID Technology¹, Hot-Spot Protect and Traceable Quality Tra.Q™.



EXTREME WEATHER RATING

High-tech aluminum alloy frame, certified for high snow (5400 Pa) and wind loads (4000 Pa).



A RELIABLE INVESTMENT

Inclusive 25-year product warranty and 25-year linear performance warranty².

¹ APT test conditions according to IEC/TS 62804-1:2015, method A (-1500 V, 96h)
² See data sheet on rear for further information.

THE IDEAL SOLUTION FOR:



Engineered in Germany



MECHANICAL SPECIFICATION

Format	74.0 in × 41.1 in × 1.26 in (including frame) (1879 mm × 1045 mm × 32 mm)
Weight	48.5 lbs (22.0 kg)
Front Cover	0.13 in (3.2 mm) thermally pre-stressed glass with anti-reflection technology
Back Cover	Composite film
Frame	Black anodized aluminum
Cell	6 × 22 monocrystalline Q.ANTUM solar half cells
Junction Box	2.09-3.98 in × 1.26-2.36 in × 0.59-0.71 in (53-101 mm × 32-60 mm × 15-18 mm), IP67, with bypass diodes
Cable	4 mm ² Solar cable; (+) ≥ 49.2 in (1250 mm), (-) ≥ 49.2 in (1250 mm)
Connector	Stäubli MC4; IP68

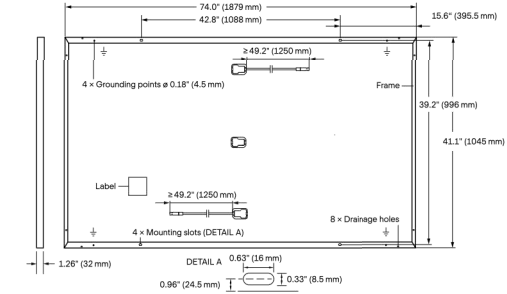

ELECTRICAL CHARACTERISTICS

POWER CLASS		385	390	395	400	405	
MINIMUM PERFORMANCE AT STANDARD TEST CONDITIONS, STC ¹ (POWER TOLERANCE +5 W / -0 W)							
Minimum	Power at MPP ¹	P _{MPP} [W]	385	390	395	400	405
	Short Circuit Current ¹	I _{SC} [A]	11.04	11.07	11.10	11.14	11.17
	Open Circuit Voltage ¹	V _{OC} [V]	45.19	45.23	45.27	45.30	45.34
	Current at MPP	I _{MPP} [A]	10.59	10.65	10.71	10.77	10.83
	Voltage at MPP	V _{MPP} [V]	36.36	36.62	36.88	37.13	37.39
	Efficiency ¹	η [%]	≥ 19.6	≥ 19.9	≥ 20.1	≥ 20.4	≥ 20.6
MINIMUM PERFORMANCE AT NORMAL OPERATING CONDITIONS, NMOT ²							
Minimum	Power at MPP	P _{MPP} [W]	288.8	292.6	296.3	300.1	303.8
	Short Circuit Current	I _{SC} [A]	8.90	8.92	8.95	8.97	9.00
	Open Circuit Voltage	V _{OC} [V]	42.62	42.65	42.69	42.72	42.76
	Current at MPP	I _{MPP} [A]	8.35	8.41	8.46	8.51	8.57
	Voltage at MPP	V _{MPP} [V]	34.59	34.81	35.03	35.25	35.46

¹ Measurement tolerances P_{MPP} ± 3%; I_{SC}; V_{OC} ± 5% at STC: 1000 W/m², 25 ± 2 °C, AM 1.5 according to IEC 60904-3 • 800 W/m², NMOT, spectrum AM 1.5

Q CELLS PERFORMANCE WARRANTY

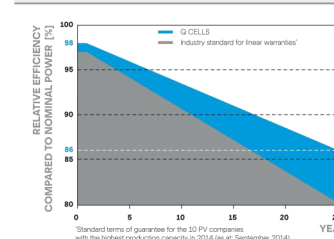

At least 98% of nominal power during first year. Thereafter max. 0.5% degradation per year. At least 93.5% of nominal power up to 10 years. At least 86% of nominal power up to 25 years.

All data within measurement tolerances. Full warranties in accordance with the warranty terms of the Q CELLS sales organisation of your respective country.

PERFORMANCE AT LOW IRRADIANCE

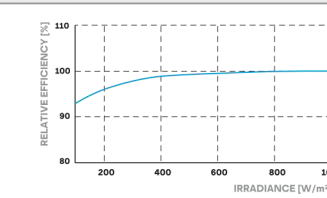

Typical module performance under low irradiance conditions in comparison to STC conditions (25 °C, 1000 W/m²)

TEMPERATURE COEFFICIENTS

Temperature Coefficient of I _{SC}	α [%/K]	+0.04	Temperature Coefficient of V _{OC}	β [%/K]	-0.27
Temperature Coefficient of P _{MPP}	γ [%/K]	-0.34	Nominal Module Operating Temperature	NMOT [°F]	109 ± 5.4 (43 ± 3 °C)

PROPERTIES FOR SYSTEM DESIGN

Maximum System Voltage V _{SYS} [V]	1000 (IEC)/1000 (UL)	PV module classification	Class II
Maximum Series Fuse Rating [A DC]	20	Fire Rating based on ANSI / UL 61730	TYPE 2
Max. Design Load, Push / Pull ³ [lbs/ft ²]	75 (3600 Pa) / 55 (2660 Pa)	Permitted Module Temperature on Continuous Duty	-40 °F up to +185 °F (-40 °C up to +85 °C)
Max. Test Load, Push / Pull ³ [lbs/ft ²]	113 (5400 Pa) / 84 (4000 Pa)		

³ See Installation Manual

QUALIFICATIONS AND CERTIFICATES

UL 61730, CE-compliant, Quality Controlled PV - TÜV Rheinland, IEC 61215:2016, IEC 61730:2016, U.S. Patent No. 9,893,215 (solar cells), QCPV Certification ongoing.



PACKAGING INFORMATION

Horizontal packaging	76.4 in 1940 mm	43.3 in 1100 mm	48.0 in 1220 mm	1656 lbs 751 kg	24 pallets	24 pallets	32 modules
----------------------	--------------------	--------------------	--------------------	--------------------	------------	------------	------------

Note: Installation instructions must be followed. See the installation and operating manual or contact our technical service department for further information on approved installation and use of this product.

Hanwha Q CELLS America Inc.
400 Spectrum Center Drive, Suite 1400, Irvine, CA 92618, USA | TEL +1 949 748 59 96 | EMAIL inquiry@us.q-cells.com | WEB www.q-cells.us

Single Phase Inverter with HD-Wave Technology

for North America

SE3000H-US / SE3800H-US / SE5000H-US / SE6000H-US / SE7600H-US / SE10000H-US / SE11400H-US

12-25
YEAR
WARRANTY



INVERTERS

Optimized installation with HD-Wave technology

- Specifically designed to work with power optimizers
- Record-breaking efficiency
- Fixed voltage inverter for longer strings
- Integrated arc fault protection and rapid shutdown for NEC 2014 and 2017, per article 690.11 and 690.12
- UL1741 SA certified, for CPUC Rule 21 grid compliance
- Extremely small
- Built-in module-level monitoring
- Outdoor and indoor installation
- Optional: Revenue grade data, ANSI C12.20 Class 0.5 (0.5% accuracy)

solaredge.com



Single Phase Inverter with HD-Wave Technology for North America

SE3000H-US / SE3800H-US / SE5000H-US / SE6000H-US / SE7600H-US / SE10000H-US / SE11400H-US

	SE3000H-US	SE3800H-US	SE5000H-US	SE6000H-US	SE7600H-US	SE10000H-US	SE11400H-US		
OUTPUT									
Rated AC Power Output	3000	3800 @ 240V 3300 @ 208V	5000	6000 @ 240V 5000 @ 208V	7600	10000	11400 @ 240V 10000 @ 208V	VA	
Maximum AC Power Output	3000	3800 @ 240V 3300 @ 208V	5000	6000 @ 240V 5000 @ 208V	7600	10000	11400 @ 240V 10000 @ 208V	VA	
AC Output Voltage Min.-Nom.-Max. (211 - 240 - 264)	✓	✓	✓	✓	✓	✓	✓	Vac	
AC Output Voltage Min.-Nom.-Max. (183 - 208 - 229)	-	✓	-	✓	-	-	✓	Vac	
AC Frequency (Nominal)	59.3 - 60 - 60.5 ¹⁾							Hz	
Maximum Continuous Output Current @240V	12.5	16	21	25	32	42	47.5	A	
Maximum Continuous Output Current @208V	-	16	-	24	-	-	48.5	A	
GFDI Threshold	1							A	
Utility Monitoring, Islanding Protection, Country Configurable Thresholds	Yes								
INPUT									
Maximum DC Power @240V	4650	5900	7750	9300	11800	15500	17650	W	
Maximum DC Power @208V	-	5100	-	7750	-	-	15500	W	
Transformer-less, Ungrounded	Yes								
Maximum Input Voltage	480							Vdc	
Nominal DC Input Voltage	380					400		Vdc	
Maximum Input Current @240V ²⁾	8.5	10.5	13.5	16.5	20	27	30.5	Adc	
Maximum Input Current @208V ²⁾	-	9	-	13.5	-	-	27	Adc	
Max. Input Short Circuit Current	45							Adc	
Reverse-Polarity Protection	Yes								
Ground-Fault Isolation Detection	600ka Sensitivity								
Maximum Inverter Efficiency	99	99.2						%	
CEC Weighted Efficiency	99						99 @ 240V 98.5 @ 208V	%	
Nighttime Power Consumption	< 2.5							W	
ADDITIONAL FEATURES									
Supported Communication Interfaces	RS485, Ethernet, ZigBee (optional), Cellular (optional)								
Revenue Grade Data, ANSI C12.20	Optional ³⁾								
Rapid Shutdown - NEC 2014 and 2017 690.12	Automatic Rapid Shutdown upon AC Grid Disconnect								
STANDARD COMPLIANCE									
Safety	UL1741, UL1741 SA, UL1699B, CSA C22.2, Canadian AFCI according to T.I.L. M-07								
Grid Connection Standards	IEEE1547, Rule 21, Rule 14 (H)								
Emissions	FCC Part 15 Class B								
INSTALLATION SPECIFICATIONS									
AC Output Conduit Size / AWG Range	1" Maximum / 14-6 AWG				1" Maximum / 14-4 AWG				
DC Input Conduit Size / # of Strings / AWG Range	1" Maximum / 1-2 strings / 14-6 AWG				1" Maximum / 1-3 strings / 14-6 AWG				
Dimensions with Safety Switch (HxWxD)	17.7 x 14.6 x 6.8 / 450 x 370 x 174				21.3 x 14.6 x 7.3 / 540 x 370 x 185				in / mm
Weight with Safety Switch	22 / 10	25.1 / 11.4	26.2 / 11.9	38.8 / 17.6				lb / kg	
Noise	< 25				< 50				dBA
Cooling	Natural Convection								
Operating Temperature Range	-13 to +140 / -25 to +60 ⁴⁾ (-40°F / -40°C option) ⁵⁾							°F / °C	
Protection Rating	NEMA 4X (Inverter with Safety Switch)								

¹⁾ For other regional settings please contact SolarEdge support

²⁾ A higher current source may be used; the inverter will limit its input current to the values stated

³⁾ Revenue grade inverter P/N: SE000H-US000NNC2

⁴⁾ For power de-rating information refer to: <https://www.solaredge.com/sites/default/files/se-temperature-derating-note-na.pdf>

⁵⁾ -40 version P/N: SE000H-US000NNU4

Power Optimizer

For North America

P320 / P340 / P370 / P400 / P405 / P505



POWER OPTIMIZER

PV power optimization at the module-level

- Specifically designed to work with SolarEdge inverters
- Up to 25% more energy
- Superior efficiency (99.5%)
- Mitigates all types of module mismatch losses, from manufacturing tolerance to partial shading
- Flexible system design for maximum space utilization
- Fast installation with a single bolt
- Next generation maintenance with module-level monitoring
- Meets NEC requirements for arc fault protection (AFCI) and Photovoltaic Rapid Shutdown System (PVRSS)
- Module-level voltage shutdown for installer and firefighter safety

solaredge.com



/ Power Optimizer For North America

P320 / P340 / P370 / P400 / P405 / P505

Optimizer model (typical module compatibility)	P320 (for 60-cell modules)	P340 (for high-power 60-cell modules)	P370 (for higher-power 60 and 72-cell modules)	P400 (for 72 & 96-cell modules)	P405 (for thin film modules)	P505 (for higher current modules)	
INPUT							
Rated Input DC Power ⁽¹⁾	320	340	370	400	405	505	W
Absolute Maximum Input Voltage (Voc at lowest temperature)	48		60	80	125 ⁽²⁾	87 ⁽²⁾	Vdc
MPPT Operating Range	8 - 48		8 - 60	8 - 80	12.5 - 105	12.5 - 87	Vdc
Maximum Short Circuit Current (Isc)	11			10.1		14	Adc
Maximum DC Input Current	13.75			12.5		17.5	Adc
Maximum Efficiency	99.5						%
Weighted Efficiency	98.8					98.6	%
Overvoltage Category	II						
OUTPUT DURING OPERATION (POWER OPTIMIZER CONNECTED TO OPERATING SOLAREEDGE INVERTER)							
Maximum Output Current	15						Adc
Maximum Output Voltage	60			85			Vdc
OUTPUT DURING STANDBY (POWER OPTIMIZER DISCONNECTED FROM SOLAREEDGE INVERTER OR SOLAREEDGE INVERTER OFF)							
Safety Output Voltage per Power Optimizer	1 ± 0.1						Vdc
STANDARD COMPLIANCE							
EMC	FCC Part15 Class B, IEC61000-6-2, IEC61000-6-3						
Safety	IEC62109-1 (class II safety), UL1741						
Material	UL94 V-0, UV Resistant						
RoHS	Yes						
INSTALLATION SPECIFICATIONS							
Maximum Allowed System Voltage	1000						Vdc
Compatible inverters	All SolarEdge Single Phase and Three Phase inverters						
Dimensions (W x L x H)	129 x 153 x 27.5 / 5.1 x 6 x 1.1		129 x 153 x 33.5 / 5.1 x 6 x 1.3	129 x 159 x 49.5 / 5.1 x 6.3 x 1.9	129 x 162 x 59 / 5.1 x 6.4 x 2.3		mm / in
Weight (including cables)	630 / 1.4		750 / 1.7	845 / 1.9	1064 / 2.3		gr / lb
Input Connector	Single or dual MC4 ⁽³⁾						
Input Wire Length	0.16 / 0.52						m / ft
Output Wire Type / Connector	Double Insulated / MC4						
Output Wire Length	0.9 / 2.95		1.2 / 3.9				m / ft
Operating Temperature Range	-40 - +85 / -40 - +185						°C / °F
Protection Rating	IP68 / NEMA6P						
Relative Humidity	0 - 100						%

⁽¹⁾ Rated power of the module at STC will not exceed the optimizer "Rated Input DC Power". Modules with up to +5% power tolerance are allowed

⁽²⁾ NEC 2017 requires max input voltage be not more than 80V

⁽³⁾ For other connector types please contact SolarEdge

PV System Design Using a SolarEdge Inverter ⁽⁴⁾⁽⁵⁾	Single Phase HD-Wave	Single phase	Three Phase 208V	Three Phase 480V	
Minimum String Length (Power Optimizers)	P320, P340, P370, P400 P405 / P505	8	10	18	
Maximum String Length (Power Optimizers)		6	13 (12 with SE3K)	14	
Maximum String Length (Power Optimizers)		25	25	50 ⁽⁶⁾	
Maximum Power per String	5700 (6000 with SE7600-US - SE11400-US)	5250	6000 ⁽⁷⁾	12750 ⁽⁸⁾	W
Parallel Strings of Different Lengths or Orientations	Yes				

⁽⁴⁾ For detailed string sizing information refer to: http://www.solaredge.com/sites/default/files/string_sizing_na.pdf

⁽⁵⁾ It is not allowed to mix P405/P505 with P320/P340/P370/P400 in one string

⁽⁶⁾ A string with more than 30 optimizers does not meet NEC rapid shutdown requirements; safety voltage will be above the 30V requirement

⁽⁷⁾ For SE14.4KUS/SE43.2KUS: It is allowed to install up to 6,500W per string when 3 strings are connected to the inverter (3 strings per unit for SE43.2KUS) and when the maximum power difference between the strings is up to 1,000W

⁽⁸⁾ For SE30KUS/SE33.3KUS/SE66.6KUS/SE100KUS: It is allowed to install up to 15,000W per string when 3 strings are connected to the inverter (3 strings per unit for SE66.6KUS/SE100KUS) and when the maximum power difference between the strings is up to 2,000W

© SolarEdge Technologies Ltd. All rights reserved. SOLAREEDGE, the SolarEdge logo, OPTIMIZED BY SOLAREEDGE are trademarks or registered trademarks of SolarEdge Technologies, Inc. All other trademarks mentioned herein are trademarks of their respective owners. Date: 07/2019/V01/ENG NAM. Subject to change without notice.

CE RoHS

SERIES 100 UL ROOF MOUNT SYSTEM

SnapNrack Solar Mounting Solutions

The SnapNrack line of solar mounting solutions is designed to reduce total installation costs. The system's technical innovations have been proven to drive down costs and improve installation quality on more than 350 MW of solar installations.

Pitched Roof Arrays Simplified

The SnapNrack Series 100 UL Roof Mount System is an efficient, visually appealing, photovoltaic (PV) module installation system. Series 100 UL is Listed to the UL Standard 2703 for Bonding, meaning that all system components have been Certified by UL for electrical continuity, eliminating the need for additional grounding hardware. The System's components provide an adequate bonding path which has eliminated the need for grounding lugs and washers at each module, and bonding jumpers between splices. The UL 2703 Listing ensures that SnapNrack partners can provide the best in class installations in quality, safety, and efficiency.

- All bonding hardware is fully integrated into the components
- No grounding lugs required for modules
- Rail splices bond rails together, no rail jumpers required
- Proprietary SnapNrack grounding lug snaps in the rail channel, no drilling of rail or reaching for other tools required (One Lug per individual row of modules)
- Class A Fire Rating Type 1 and 2 modules

Patent Pending



Roof System in 4 Simple Steps:

- 1) Go to the online Series 100 Configuration Tool (configure.snapnrack.com) and select "Yes" for UL 2703 Listed
- 2) Identify Site Conditions (Array Tilt, Building Height, Roof Type, Wind and Snow Loads)
- 3) Build array in the online Configuration Tool and automatically generate a Bill of Materials.
- 4) Place order with your distributor. Purchase material for a single project or order in bulk for additional savings

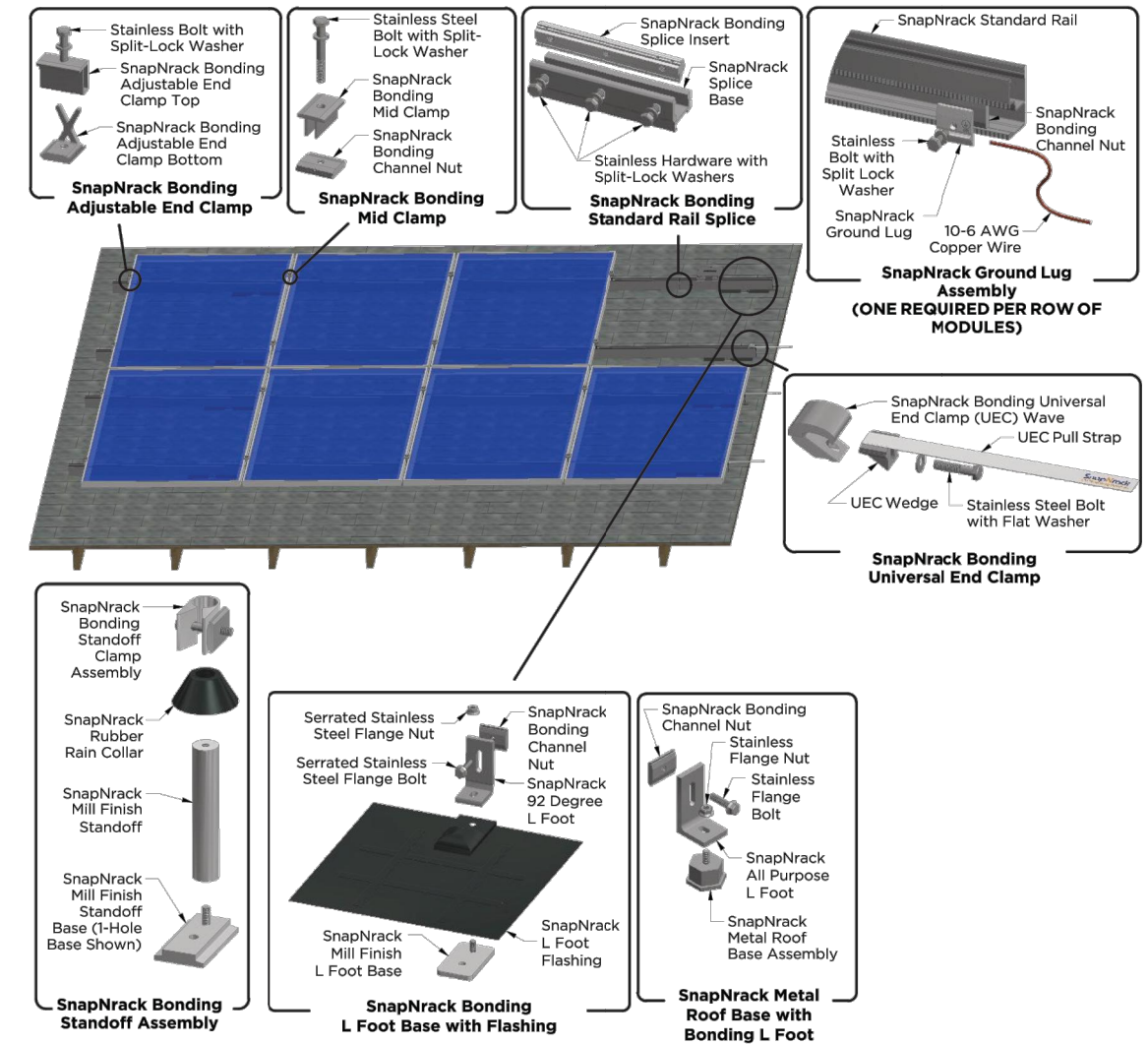

SnapNrack Series 100 UL Technical Data <small>Patent Pending</small>	
Materials	<ul style="list-style-type: none"> • 6000 Series aluminum • Stainless steel • Galvanized Steel and Aluminum Flashing
Material Finish	<ul style="list-style-type: none"> • Clear and black anodized aluminum • Mill Finish on select components
Installation	<ul style="list-style-type: none"> • Quick and efficient mounting • Adjustable hardware to ensure clean and level finish • All components bonded to ground with integrated bonding features
Calcs. & Certifications	<ul style="list-style-type: none"> • Listed to UL Standard 2703 for Grounding/Bonding and Fire Classification • Class A Fire Rating Type 1 and Type 2 Modules • Stamped Structural Engineering Reports for all 50 States
Grounding	<ul style="list-style-type: none"> • SnapNrack Grounding Lug (One Lug per individual row of modules)
Warranty	<ul style="list-style-type: none"> • 10 Year material and workmanship (download full details at snapnrack.com)

SnapNrack™
Solar Mounting Solutions
(877) 732-2860 www.SnapNrack.com

Printed on recycled paper using soy based inks.
© 2015 by SnapNrack PV Mounting System. All rights reserved.

SERIES 100 UL FLASHED L FOOT KIT

SnapNrack Solar Mounting Solutions

The SnapNrack line of solar mounting solutions is designed to reduce total installation costs. The system's technical innovations have been proven to drive down costs and improve installation quality on more than 350 MW of solar installations.

Flashed L Foot Simplified

SnapNrack Series 100 Flashed L Foot Kit is an innovative solution to provide a long lasting watertight seal over the life of the system. The Flashed L Foot provides a fully flashed roof fastener for attachment to composition roof with no required cutting of shingles. The L Foot is engineered for maximum adjustability for a clean level installation.

- 1" slotted bolt connection
- 1" spacers available for increased adjustability
- Clear or Black anodized aluminum components (both available with black flashing)
- No Cutting of shingles

Patent Pending



Flashed L Foot in 4 Simple Steps:

- 1) Locate a rafter in the roof using a pilot drill
- 2) Install base to the roof on top of the composition shingle
- 3) Use a breaker bar to separate the composition shingles above the base, and install the flashing
- 4) Attach the L foot on top and proceed with rail installation and leveling

Place order with your distributor. Purchase material for a single project or order in bulk for additional savings



Flashed L Foot Kit Parts



Flashed L Foot Kit Assembled

Flashed L Foot Kit Assembly

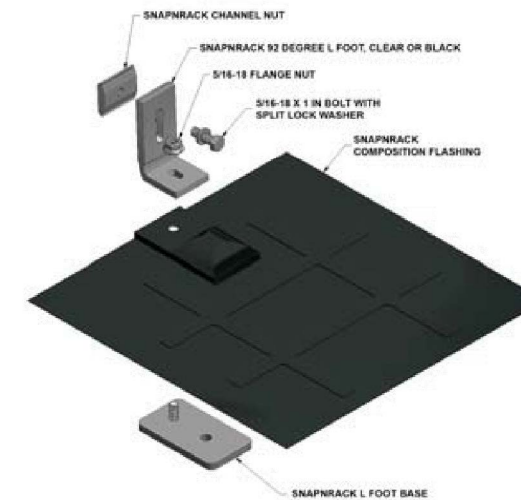

Flashed L Foot Kit Dimensions

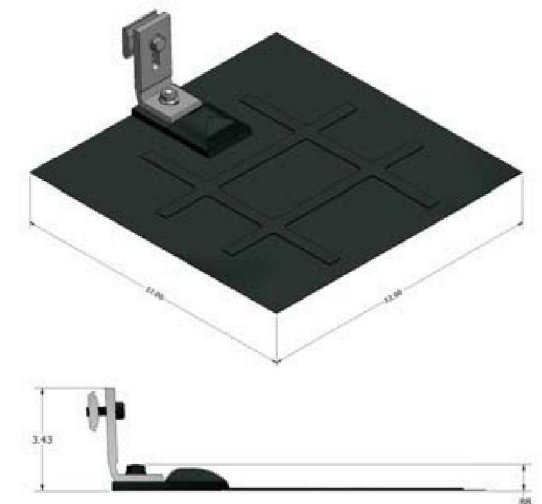

SnapNrack Flashed L Foot Technical Data Patent Pending

Materials	<ul style="list-style-type: none"> • 6000 Series Aluminum L Foot & Base • Stainless Steel Hardware • Galvanized Steel Flashing w/ black all weather coating
Material Finish	• Clear and black anodized aluminum
Weight	• 1.3 lbs
Design Uplift Load	• 350 lbs Uplift
Design Ultimate Load	• 1,000 lbs Uplift
Warranty	• 10 Year material and workmanship

SnapNrack™
Solar Mounting Solutions

(877) 732-2860 www.SnapNrack.com

Printed on recycled paper using soy based inks.

© 2015 by SnapNrack PV Mounting System. All rights reserved.