

SOLAR MODULE SPECIFICATIONS	
MANUFACTURER / MODEL #	LG ELECTRONICS LG375N1C-A6
VMP	35.3V
IMP	10.63A
VOC	41.8V
ISC	11.35A
TEMP. COEFF. VOC	-0.26%/°C
MODULE DIMENSION	68.50"L x 41"W x 1.57"D (In Inch)

INVERTER SPECIFICATIONS	
MANUFACTURER / MODEL #	ENPHASE IQ7PLUS-72-2-US MICROINVERTER
MIN/MAX DC VOLT RATING	22V MIN/ 60V MAX
MAX INPUT POWER	235W-440W
NOMINAL AC VOLTAGE RATING	240V/ 211-264V
MAX AC CURRENT	1.21A
MAX MODULES PER STRING	13 (SINGLE PHASE)
MAX OUTPUT POWER	290 VA

WIRE /CONDUIT SCHEDULE	
TAG	DESCRIPTION
1	#12/2 ROMEX IN ATTIC/ #12 THWN-2 ON EXTERIOR & (1)#6 THWN-2 GROUND / (GN)
2	#6 THWN-2 & (1)#6 THWN-2 GROUND / (GN)
3	#6 THWN-2 & (1)#6 THWN-2 GROUND / (GN)
4	(1)#6 BARE GROUND

DC SIZE 38 X 375W = 14.250 kW DC-STC
 AC SIZE 38X 290W = 11.020 kW AC

(GN) GENERAL CONDUIT NOTE :
 CONDUIT TO BE UL LISTED FOR WET LOCATIONS AND UV PROTECTED (EX. -EMT,SCH 80 PVC OR RMC)*FMC MAYBE USED IN INDOOR APPLICATIONS WHERE PERMITTED BY NEC ART .348

CONTRACTOR
SUNPRO

22171 MCH RD
 MANDEVILLE, LA 70471
 PHONE: 9152011490

PROJECT NAME & ADDRESS
MARK VARLEY
116 SOUTHERN PL, LILLINGTON, NC 27546

COUNTY: HARNETT COUNTY

SYSTEM SIZE
 DC SIZE: 14.250 KW DC-(STC)
 AC SIZE: 11.020 KW AC

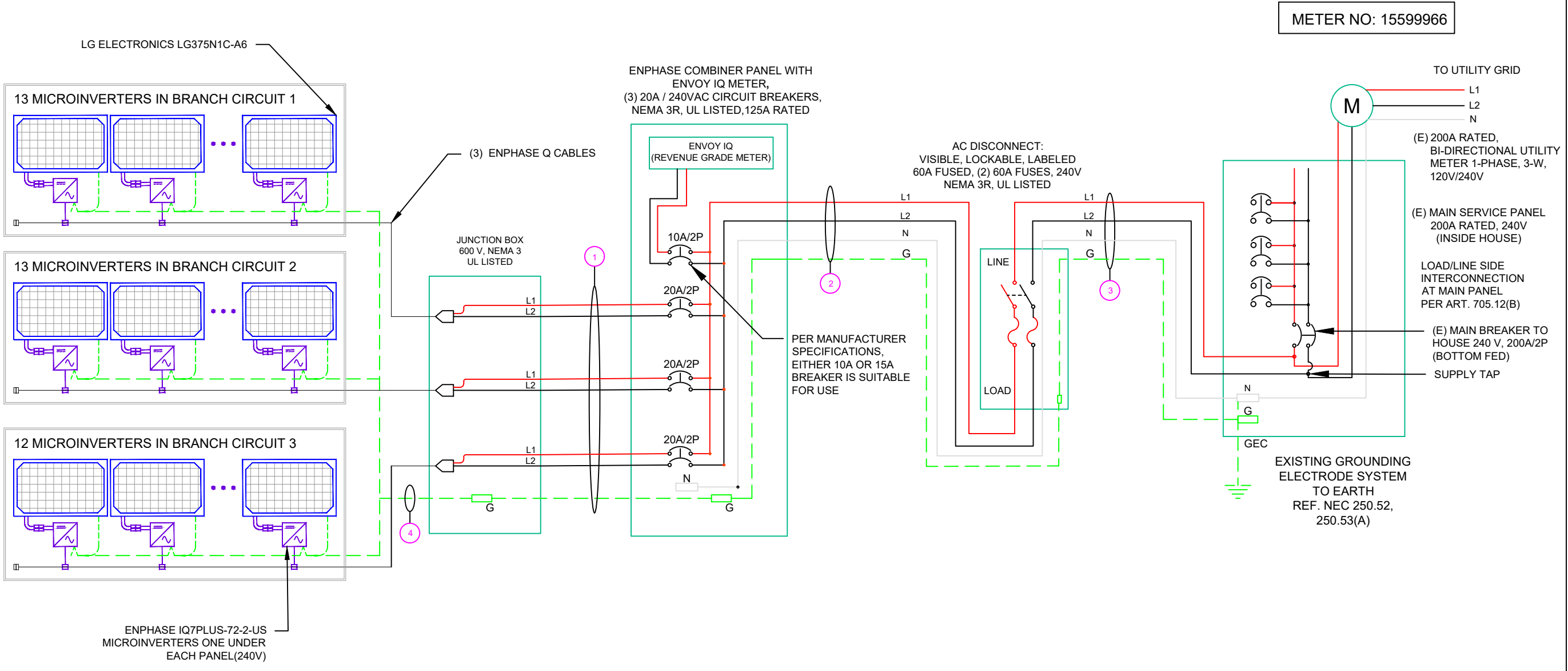

ENGINEER:

SHEET TITLE
LINE DIAGRAM

DRAWN DATE	9/9/2021
DRAWN BY	NSS

SHEET NUMBER
E-601

AMBIENT TEMPERATURE SPECS	
RECORD LOW TEMP	-10°
AMBIENT TEMP (HIGH TEMP 2%)	36°
CONDUIT HEIGHT	0.5"
CONDUCTOR TEMPERATURE RATE	90°

PERCENT OF VALUES	NUMBER OF CURRENT CARRYING CONDUCTORS
.80	4-6
.70	7-9
.50	10-20

CALCULATIONS:

1. CURRENT CARRYING CONDUCTOR

(A) BEFORE IQ COMBINER PANEL

AMBIENT TEMPERATURE - (36)°C ...NEC 310.15(B)(3)(c)

TEMPERATURE DERATE FACTOR - 0.91 ...NEC

310.15(B)(2)(a)

GROUPING FACTOR - 0.8...NEC 310.15(B)(3)(a)

CONDUCTOR AMPACITY

= (INV O/P CURRENT) x 1.25 / A.T.F / G.F ...NEC 690.8(B)

= [(13 x 1.21) x 1.25] / [0.91 x 0.8]

= 27.01A

SELECTED CONDUCTOR - #12 THWN-2 ...NEC 310.15(B)(16)

(B) AFTER IQ COMBINER PANEL

TEMPERATURE DERATE FACTOR - 0.91

GROUPING FACTOR - 1

CONDUCTOR AMPACITY

= (TOTAL INV O/P CURRENT) x 1.25 / 0.91/ 1 ...NEC 690.8(B)

= [(38 x 1.21) x 1.25] / [0.91 x 1]

= 63.16 A

SELECTED CONDUCTOR - #6 THWN-2 ...NEC 310.15(B)(16)

2. PV OVER CURRENT PROTECTION ...NEC 690.9(D)

= TOTAL INVERTER O/P CURRENT x 1.25

= (38 x 1.21) x 1.25 = 57.48 A

CONTRACTOR
SUNPRO

22171 MCH RD
MANDEVILLE, LA 70471
PHONE: 9152011490

PROJECT NAME & ADDRESS

MARK VARLEY

116 SOUTHERN
PL, LILLINGTON,
NC 27546

COUNTY: HARNETT COUNTY

SYSTEM SIZE

DC SIZE: 14.250 KW DC-(STC)
AC SIZE: 11.020 KW AC

ENGINEER:

SHEET TITLE
**ELECTRICAL
CALCULATIONS**

DRAWN DATE 9/9/2021

DRAWN BY NSS

SHEET NUMBER

E-602