

THIS DISTRIBUTED GENERATION FACILITY WAS INSTALLED IN ACCORDANCE WITH THE CURRENT STATE ADOPTED NATIONAL ELECTRICAL CODE

**DESIGN SUMMARY**

- **SIZE:** 7.380 kW PV Solar System (18 modules)
- **STYLE:** Residential, asphalt shingle roof, flush mount, grid tied, net-metered
- **LOCATION:** East facing roof of home
- **ORIENTATION:** Portrait, 34° pitch, 109° azimuth
- **MODULE:** SunPower SPR-A410-G-AC 410W, 72.2"x 40"x 1.3" thick, 46.5 lbs
- **RACKING:** SunPower Invisimount with asphalt shingle roof flashings
- **INVERTER:** SunPower Type G (IQ7AS) Integrated Microinverter
- **VOLTAGE:** 120/240V, 1Φ
- **MONITORING:** Online mySunPower Monitoring
- **ADDITIONAL WORK:** None

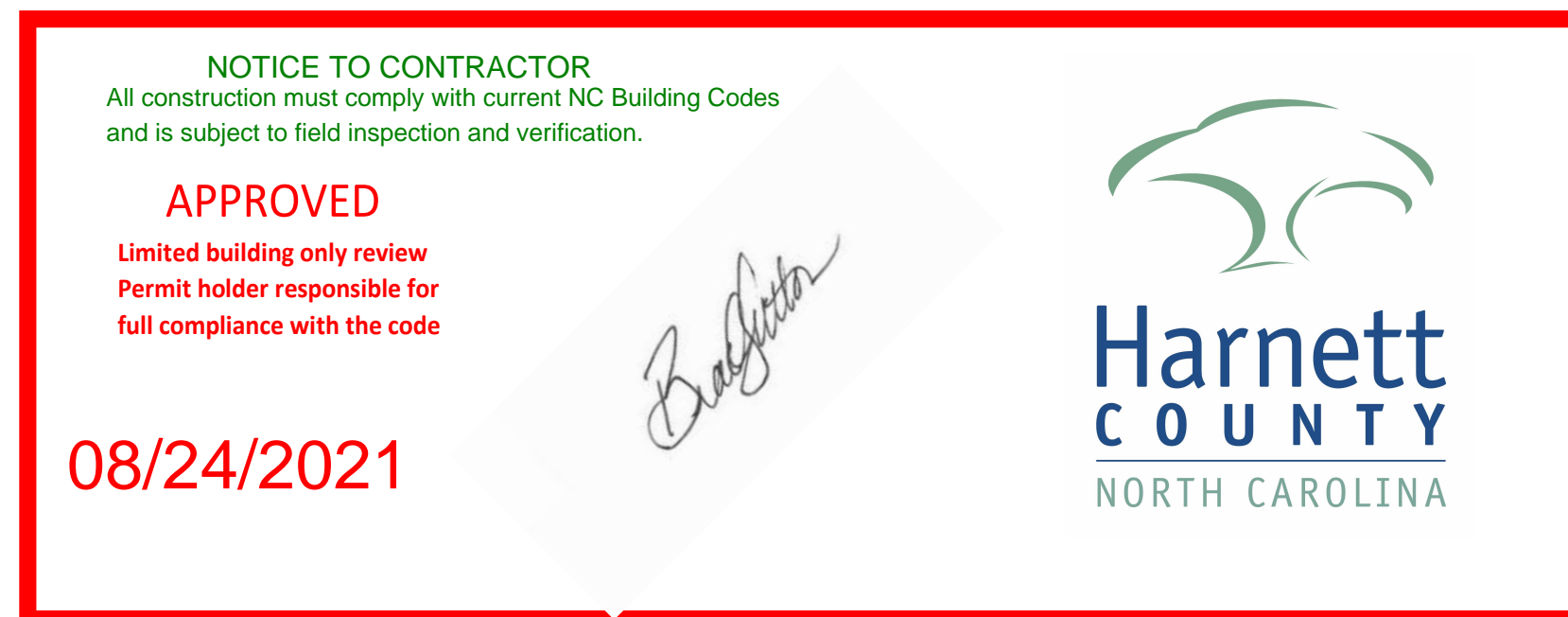

**CONTRACTOR**

**MOXIE SOLAR**

(855) 669-4387  
 INFO@MOXIESOLAR.COM  
 323 W CHERRY ST  
 NORTH LIBERTY, IA 52317

**OWNER**

**NICHOLAS TROYER**

(816) 588-7768  
 SOCKNRLS@GMAIL.COM  
 295 BANDANA WAY  
 CAMERON, NC 28326

**A H J**

**HARNETT COUNTY**

(910) 893-7525  
 420 MCKINNEY PKWY  
 LILLINGTON, NC 27546

**UTILITY**

**CENTRAL ELECTRIC  
 MEMBERSHIP CORP**





(919) 774-4900

**REVISIONS**

08/05/21	PLAN SET	KK
08/11/21	REV 1	ZZ

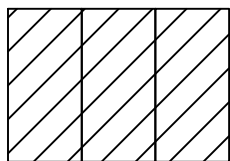
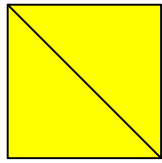
**DESIGN SUMMARY**

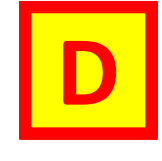
**01**

-  **PV Solar Array**  
Roof of building
-  **SunPower Integrated Microinverter Array**
-  **PV Solar Dedicated Load Center**  
Building Exterior
-  **AC Solar Disconnect**  
Building Exterior
-  **Utility Meter**  
Building Exterior
-  **Main Service Panel**  
Building Interior



**BUILD SUMMARY**

- **MODULE:** QTY (18) SPR-A410-G-AC 410W, 72.2"x 40"x 1.3" thick, 46.5 lbs
- **STRUCTURE:** Wood 2"x 8" rafters @ 16" OC
- **RACKING:** SunPower Invisimount with asphalt shingle roof flashing. Run rails across the rafters. Penetrate every 4ft or less into rafters. Installer must verify all penetrations are secure and centered in wood members. Any damaged wood members must be repaired immediately by scab, sister, or full replacement. Max Rail Overhang = 19" from last attachment point. Module Overhang = 18"
- **ACCESS:** 2-story residence
- **INVERTERS:** Factory installed microinverters
- **MONITORING:** Online mySunPower Monitoring utilizing existing wireless router
- **ADDITIONAL WORK:** None

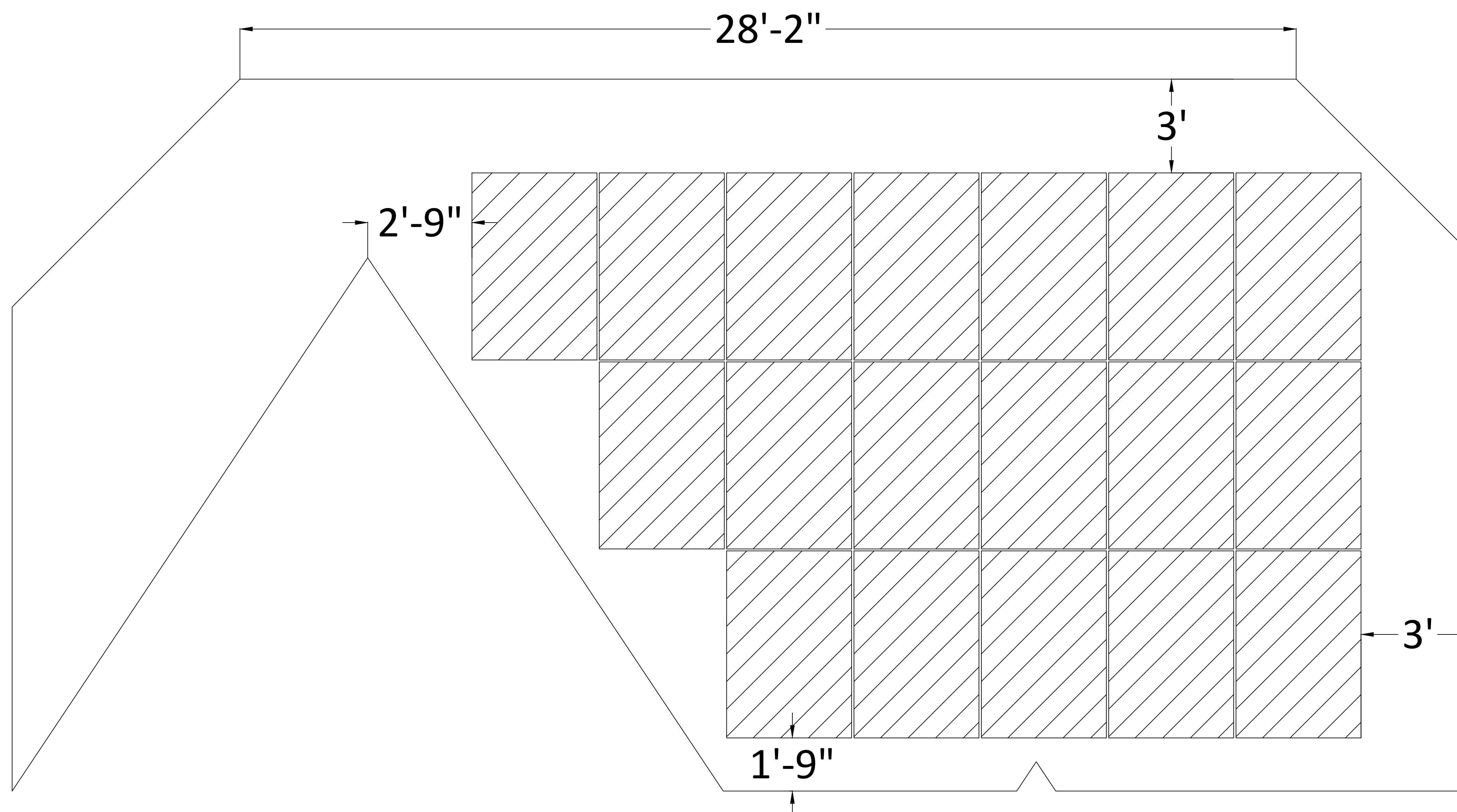

**CONTRACTOR**

**MOXIE SOLAR**

(855) 669-4387  
 INFO@MOXIESOLAR.COM  
 323 W CHERRY ST  
 NORTH LIBERTY, IA 52317

**OWNER**

**NICHOLAS TROYER**

(816) 588-7768  
 SOCKNRLS@GMAIL.COM  
 295 BANDANA WAY  
 CAMERON, NC 28326

**A H J**

**HARNETT COUNTY**

(910) 893-7525  
 420 MCKINNEY PKWY  
 LILLINGTON, NC 27546

**UTILITY**

**CENTRAL ELECTRIC MEMBERSHIP CORP**

(919) 774-4900

**REVISIONS**

08/05/21	PLAN SET	KK
08/11/21	REV 1	ZZ

**BUILD SUMMARY**

# PROJECT NAME: TROYER, NICHOLAS

# NC-4526-1

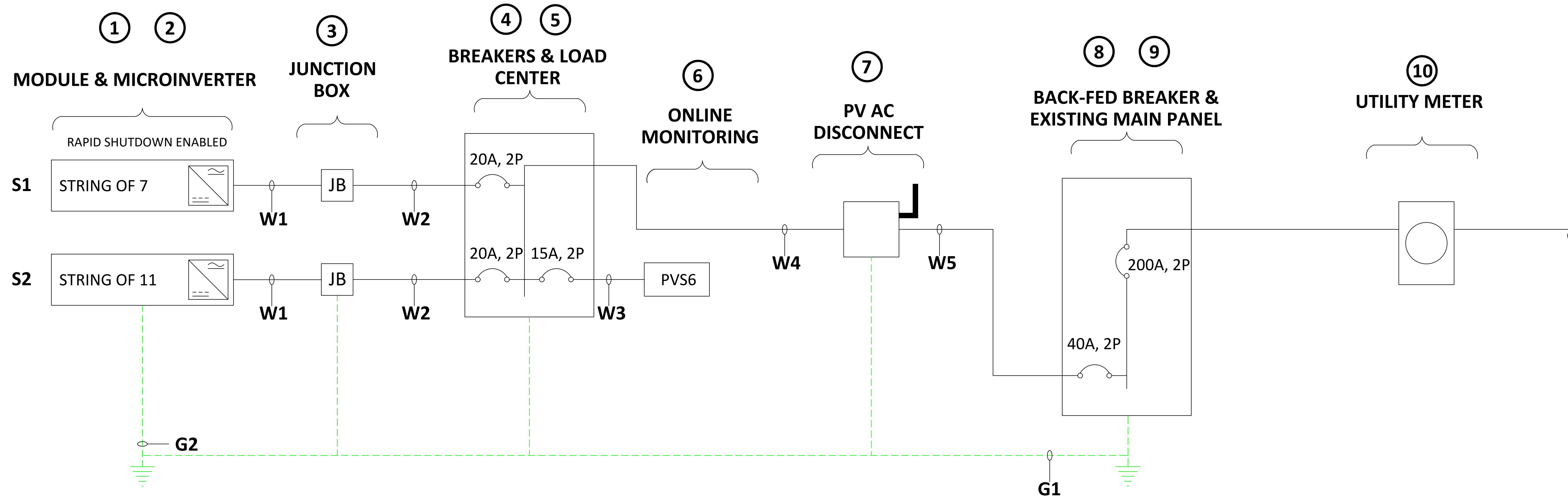

**1** ONE-LINE ELECTRICAL DIAGRAM - 7.380 KW (DC)  
**03** NO SCALE

EQUIPMENT SCHEDULE						
TAG	ITEM	MAKE	MODEL	VOLTAGE	QTY	LOCATION
1	MODULE	SUNPOWER	SPR-A410-G-AC 410W	DC	18	ROOF TOP
2	MICROINVERTER	SUNPOWER	TYPE G (IQ7AS) 349W (AC)	120/240V, 1Φ	18	ROOF TOP
3	JUNCTION BOX	SUNPOWER	XL-530167	120/240V, 1Φ	2	ROOF TOP
4	BREAKERS	EATON	20A, 2-POLE BR220	120/240V, 1Φ	2	LOAD CENTER
4	BREAKERS	EATON	15A, 2-POLE BR215	120/240V, 1Φ	1	LOAD CENTER
5	LOAD CENTER	EATON	125A ENCLOSURE LUG ONLY BR816L125RP	120/240V, 1Φ	1	BLD EXTERIOR
6	ONLINE MONITORING	SUNPOWER	PV SUPERVISOR 6	120/240V, 1Φ	1	BLD EXTERIOR
7	DISCONNECT	EATON	60A ENCLOSURE NON FUSED DG222URB, DG100NB	120/240V, 1Φ	1	BLD EXTERIOR
8	BACK-FED BREAKER	SIEMENS	40A, 2-POLE QP240	120/240V, 1Φ	1	MAIN PANEL
9	MAIN PANEL	SIEMENS	200A ENCLOSURE 200A MAIN	120/240V, 1Φ	1	BLD INTERIOR
10	UTILITY METER	LANDIS+GYR	CL200	120/240V, 1Φ	1	BLD EXTERIOR

WIRE SCHEDULE					
TAG	RUN	CONDUCTOR TYPE	GAUGE	CONDUIT	RUN LENGTH
W1	PV HOMERUNS	Q-CABLE Q-12-10-240-PORT	#12	-	60 FT
W2	JUNCTION BOX TO LOAD CENTER	THWN-2, Cu	#10	¾"	30 FT
W3	LOAD CENTER TO PVS6	THWN-2, Cu	#12	¾"	10 FT
W4	LOAD CENTER TO DISCONNECT	THWN-2, Cu	#8	1"	5 FT
W5	DISCONNECT TO BACK-FED	THWN-2, Cu	#8	1"	5 FT
G1	GROUND ELECTRODE	BARE, Cu	#4	-	-
G2	EQUIPMENT GROUND (as per NEC 250.122)	THWN-2, Cu	#10 - #4	-	100 FT

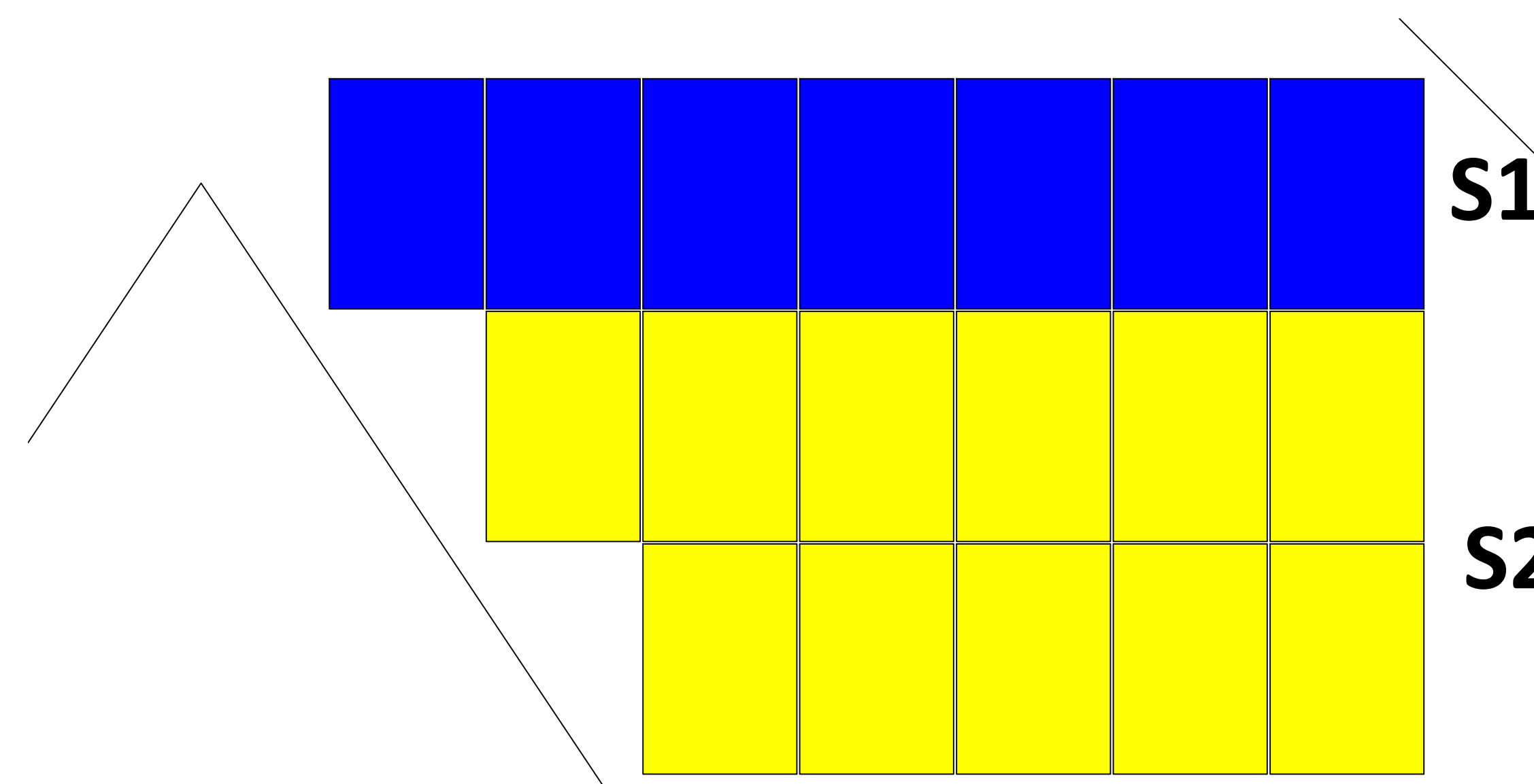

**CONTRACTOR**

**MOXIE SOLAR**

(855) 669-4387  
 INFO@MOXIESOLAR.COM

323 W CHERRY ST  
 NORTH LIBERTY, IA 52317

**OWNER**

**NICHOLAS TROYER**

(816) 588-7768  
 SOCKNRLS@GMAIL.COM

295 BANDANA WAY  
 CAMERON, NC 28326

**A H J**

**HARNETT COUNTY**

(910) 893-7525

420 MCKINNEY PKWY  
 LILLINGTON, NC 27546

**UTILITY**  
**CENTRAL ELECTRIC**  
**MEMBERSHIP CORP**

(919) 774-4900

**REVISIONS**

08/05/21 PLAN SET KK

08/11/21 REV 1 ZZ

**ELECTRICAL**

**03**



CONTRACTOR

**MOXIE SOLAR**

(855) 669-4387  
INFO@MOXIESOLAR.COM

323 W CHERRY ST  
NORTH LIBERTY, IA 52317

OWNER

**NICHOLAS TROYER**

(816) 588-7768  
SOCKNRLS@GMAIL.COM

295 BANDANA WAY  
CAMERON, NC 28326

A H J

**HARNETT COUNTY**

(910) 893-7525  
420 MCKINNEY PKWY  
LILLINGTON, NC 27546

UTILITY  
**CENTRAL ELECTRIC  
MEMBERSHIP CORP**

(919) 774-4900

REVISIONS

08/05/21	PLAN SET	KK
08/11/21	REV 1	ZZ

DETAILS & CALCULATIONS

04

CODE REVIEW & CALCULATIONS

**SOLAR PHOTOVOLTAIC (PV) SYSTEM WITH SUNPOWER**

Inverter Type: Type G (IQ7AS) MicroInverter  
Minimum String Length: N/A  
Maximum String Length: 11  
Nominal String AC Voltage: 240V (AC)  
Nominal Output Current (Per MicroInverter): 1.45A

**SunPower SPR-A410-G-AC 410W**

**NEC 690.7 MAXIMUM VOLTAGE**

690.7(A): Maximum Photovoltaic System Voltage  
SPR-A410-G-AC 410W Module  $V_{oc} = 48.20V$   
Module  $V_{max} = ((-40^{\circ}C) - 25^{\circ}C)(-0.0014/^{\circ}C)(48.20V) + (48.20V) = 52.59V$  (DC)  
Module  $V_{max}$  Output = 52.59V (DC) < TYPE G (IQ7AS) MAX Input = 80V (DC)

**NEC 690.8 CIRCUIT SIZING AND CURRENT**

690.8(A)(1): Photovoltaic Source Circuit Currents  
Module to MicroInverter  $I_{max} = 1.45A \times 18 \times 125\% = 32.63A$

690.8(A)(3): Inverter Output Circuit Current.  
MicroInverter Rated Continuous Output Power = 349W  
MicroInverter rated Continuous Output Current = 1.45A  
System  $I_{max} = 32.63A$

**NEC 690.9 OVERCURRENT PROTECTION**

690.9(B): Overcurrent Device Ratings  
Disconnect Fuse:  $1.45A \times 18 \times 125\% = 32.63A \rightarrow 40A$  OCPD

**NEC 690.12 RAPID SHUTDOWN OF PV SYSTEMS ON BUILDINGS**

PLAN: Rapid Shutdown enabled disconnect shall be located next to the service and be labeled in accordance with 690.56(B) and (C).

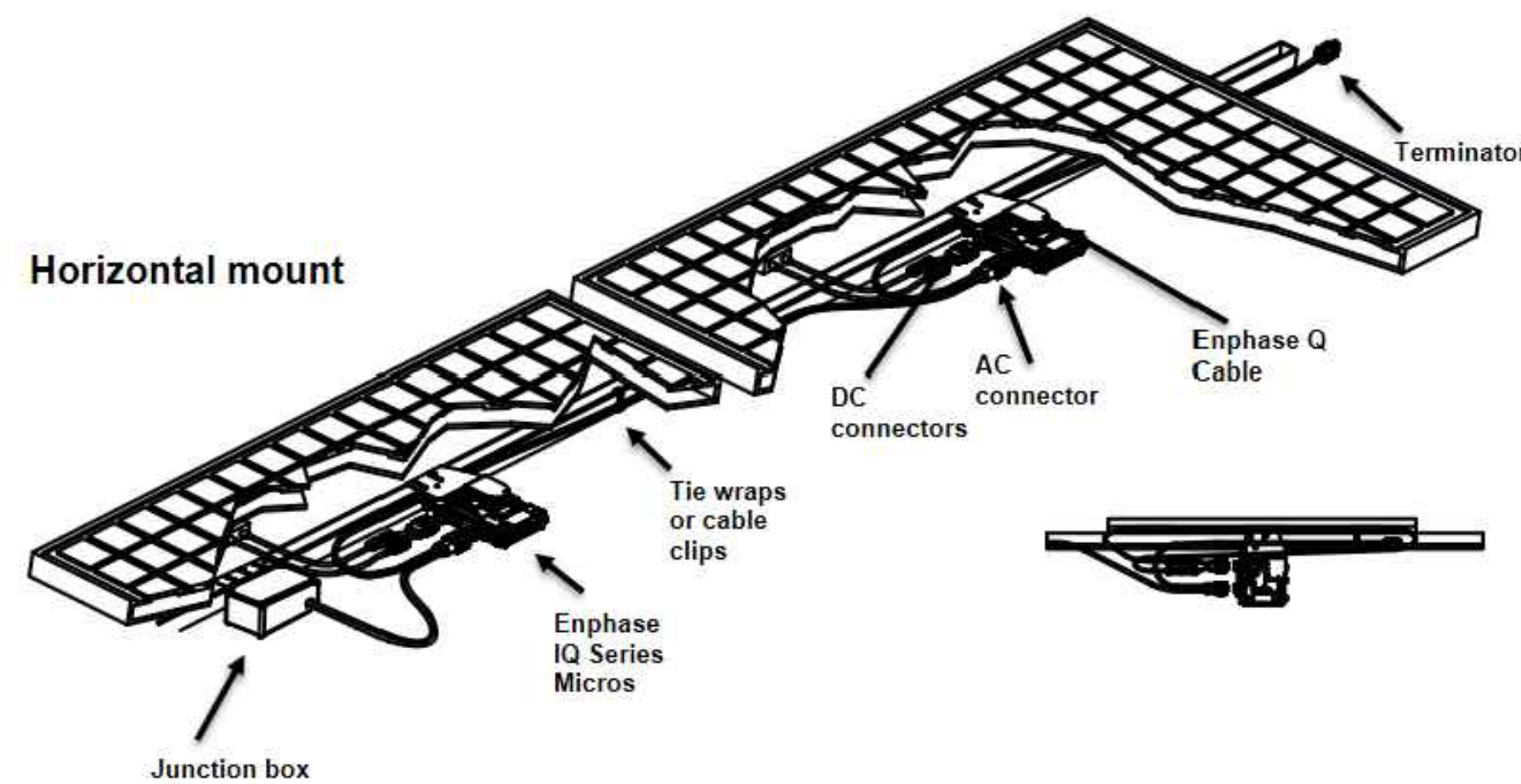

1 04 MODULE AND MICROINVERTER CONNECTION DETAIL

NO SCALE



2 04 SUNPOWER INVISIMOUNT ROOF FLASHING DETAIL

NO SCALE

**SYSTEM AC DISCONNECT AT SERVICE**

PHOTOVOLTAIC SYSTEM AC DISCONNECT  
MAXIMUM OPERATING AC CURRENT: 26.10 AMPS  
NOMINAL OPERATING AC VOLTAGE: 120/240 VAC

3 04 PHOTOVOLTAIC MARKING AND LABELING

NO SCALE

## Roof Assessment for Solar Panel Installation

**Date:** August 16, 2021  
**Prepared for:** C&S Troyer 17p R  
**Project Number:** 210708  
**Assessment Date:** August 13, 2021  
**Site Address:** 295 Bandana Way Cameron NC 28326  
**Purpose:** Structural Roof Assessment for installation of 17 panel solar array.  
**Prepared by:** Landon Wilson & Clay Medlin, PE, NC #048735  
**NC COL:** C-3298, CDR & Assoc., Inc.



CDR & Assoc., Inc. thanks you for the opportunity to provide you with a letter for the inspection of the roof framing for the installation of solar panel system on the roof of the foresaid property hereafter referred to as "house". All references to directions or locations indicated in this report are by facing the front of the house.

### **Observations and Analysis of Roof**

- **Basis of Evaluation:** The engineering analysis is based on measurements and photographs taken onsite by CDR+A technician, Brady Jarvis.
- **Roof Construction:** A asphalt shingles roof over wood decking on rafter members.
- **Roof Pitch:** 7.5 on 12
- **Solar Panel Array:** 17 panels.
- **Total Array Square Footage:** The panels are approximately 39.37" x 64.57" or 17.65 sf each, round up to 18 sf x 17 panels = total surface area of 306 sf.
- **Total weight of Array:** Panel weighs approximately 40 lbs. ea. X 17= 680 lbs. for the Array.
- **Total Additional Weight on Roof:** 680 lbs / 306 sf = 2.22 psf add for rail mount system, assume 3 psf additional load on roof structure.
- **Rail Mount System:** The panels are mounted on aluminum rails at top and bottom of the panels for each row of panels.

- **Analysis of Roof Structure:**

- Additional dead load 15 psf (12 psf plus 3 psf from solar array)
  - Roof Live Load - 20 psf. (Allowable Residential Code w/o reductions)
  - The 2x8 SP rafters spaced 16" apart were analyzed (worst case).
  - Roof Pitch 6/12
  - The maximum unbraced span: 9' 0" measured horizontal.
  - Analysis with the additional roof load determined that the roof Rafters are 22% stressed. The Rafters are in compliance with the current Residential Building Code.
- **Wind Speed:** Components and cladding 118 mph wind load uplift of -40 psf.
  - **Total Wind Load Uplift:** -40 psf x 306 sf = 12,240 lbs total uplift for solar array.
  - **Number of Attachment Anchors:** Use a minimum of two (2) bracket per panel (one top and bottom) or less to meet rail manufacturers recommended support needs = 34 total attachment brackets.
  - **Wind Load Uplift per Anchor:** 12,240 lbs total uplift / 34 = 360 lbs for solar array.
  - **Strength of Hold-down Anchors:** Pegasus Solar® L-Foot the SunPower InvisiMount is reported to be used with the Pegasus Solar L-Foot. The L-Foot is attached directly into the top of the rafter members with 5/16" stainless steel lag screw with at least 3" of embedment into the wood member. The load testing results determined an average pullout failure load of 556 lbs per screw, exceeding the required 360 lbs per anchor. The loading proposed creates a safety factor of 1.54 or greater for the attachment.

### **Conclusions & Recommendations**

By analysis it was determined that the roof rafter members were adequate for the addition load of the solar panel array.

The installation of the solar panel array using the Pegasus Solar® L-Foot attachment bracket directly to the top of the wood members with one 5/16" stainless steel lag screw per manufacturers spec. is adequate for the loads imposed on them.

### **Closure**

We appreciate the opportunity to provide structural assessment services to you. Please contact us should you have any questions.

Sincerely,

CDR+A Structural Engineers



## 420–390 W Residential AC Module

SunPower® Maxeon® Technology

Built specifically for use with the SunPower Equinox™ system, the only fully integrated solution designed, engineered, and warranted by one manufacturer.



### Highest Power Density Available.

SunPower's new Maxeon® Gen 5 cell is 65% larger than prior generations, delivering the most powerful cell and highest-efficiency module in residential solar. The result is more power per square meter than any commercially available solar.

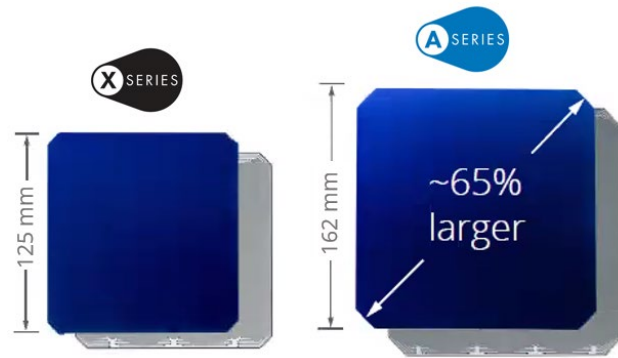

### Fundamentally Different. And Better.

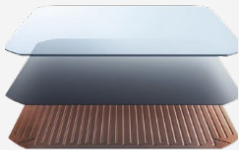

#### SunPower® Maxeon® Technology

- Most powerful cell in home solar <sup>2</sup>
- Delivers unmatched reliability <sup>3</sup>
- Patented solid metal foundation prevents breakage and corrosion



#### Factory-integrated Microinverter (MI)

- Highest-power integrated AC module in solar
- 60% lighter than prior SunPower MIs
- Engineered and calibrated by SunPower for SunPower AC modules



### Highest Lifetime Energy and Savings.

Designed to deliver 60% more energy over 25 years in real-world conditions like partial shade and high temperatures.<sup>1</sup>

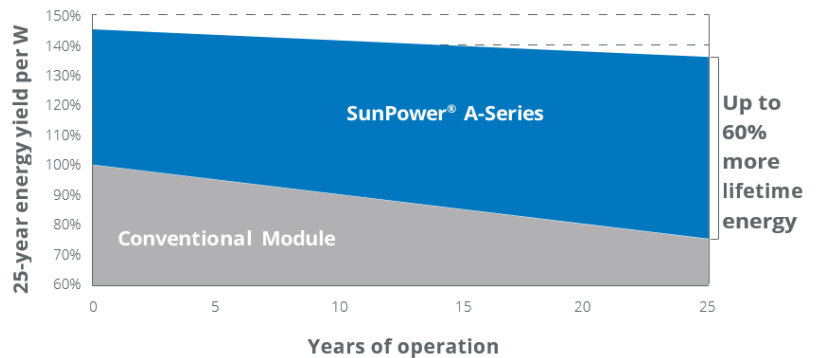

### Best Reliability. Best Warranty.

With more than 25 million modules deployed around the world, SunPower technology is proven to last. That's why we stand behind our module and microinverter with the industry's best 25-year Combined Power and Product Warranty, including the highest Power Warranty in solar.



AC Electrical Data	
Inverter Model: Type G / SPWR-A4 (IQ 7AS)	@240 VAC
Peak Output Power	366 VA
Max. Continuous Output Power	349 VA
Nom. (L-L) Voltage/Range <sup>2</sup> (V)	240 / 211–264
Max. Continuous Output Current (A)	1.45
Max. Units per 20 A (L-L) Branch Circuit <sup>3</sup>	11
CEC Weighted Efficiency	97.0%
Nom. Frequency	60 Hz
Extended Frequency Range	47–68 Hz
AC Short Circuit Fault Current Over 3 Cycles	5.8 A rms
Overvoltage Class AC Port	III
AC Port Backfeed Current	18 mA
Power Factor Setting	1.0
Power Factor (adjustable)	0.7 lead. / 0.7 lag.

DC Power Data					
	A420-G-AC	A415-G-AC	A410-G-AC	A400-G-AC	A390-G-AC
Nom. Power <sup>5</sup> (Pnom) W	420	415	410	400	390
Power Tol.	+5/-0%				
Module Efficiency	22.5	22.3	22.0	21.5	20.9
Temp. Coef. (Power)	-0.29%/°C				
Shade Tol.	Integrated module-level max. power point tracking				

Tested Operating Conditions	
Operating Temp.	-40°F to +185°F (-40°C to +85°C)
Max. Ambient Temp.	122°F (50°C)
Max. Test Load <sup>7</sup>	Wind: 125 psf, 6000 Pa, 611 kg/m <sup>2</sup> back Snow: 187 psf, 9000 Pa, 917 kg/m <sup>2</sup> front
Design Load	Wind: 75 psf, 3600 Pa, 367 kg/m <sup>2</sup> back Snow: 125 psf, 6000 Pa, 611 kg/m <sup>2</sup> front
Impact Resistance	1 inch (25 mm) diameter hail at 52 mph (23 m/s)

Mechanical Data	
Solar Cells	66 Monocrystalline Maxeon Gen 5
Front Glass	High-transmission tempered glass with anti-reflective coating
Environmental Rating	Outdoor rated
Frame	Class 1 black anodized (highest AAMA rating)
Weight	46.5 lbs (21.1 kg)
Recommended Max. Module Spacing	1.3 in. (33 mm)

1 SunPower 415 W, 22.3% efficient, compared to a Conventional Panel on same-sized arrays (260 W, 16% efficient, approx. 1.6 m<sup>2</sup>), 7.9% more energy per watt (based on PVSyst pan files for avg. US climate), 0.5%/yr slower degradation rate (Jordan, et. al. "Robust PV Degradation Methodology and Application." PVSC 2018).  
 2 Based on search of datasheet values from websites of top 10 manufacturers per IHS, as of January 2019.  
 3 #1 rank in "Fraunhofer PV Durability Initiative for Solar Modules: Part 3." PVTech Power Magazine, 2015. Campeau, Z. et al. "SunPower Module Degradation Rate," SunPower white paper, 2013.  
 4 Factory set to 1547a-2014 default settings. CA Rule 21 default settings profile set during commissioning.  
 5 Standard Test Conditions (1000 W/m<sup>2</sup> irradiance, AM 1.5, 25°C). NREL calibration standard: SOMS current, LACCS FF and voltage. All DC voltage is fully contained within the module.  
 6 This product is UL Listed as PVRSE and conforms with NEC 2014 and NEC 2017 690.12; and C22.1-2015 Rule 64-218 Rapid Shutdown of PV Systems, for AC and DC conductors; when installed according to manufacturer's instructions.  
 7 Please read the safety and installation instructions for more information regarding load ratings and mounting configurations.

See [www.sunpower.com/facts](http://www.sunpower.com/facts) for more reference information.  
 For more details, see extended datasheet [www.sunpower.com/datasheets](http://www.sunpower.com/datasheets) Specifications included in this datasheet are subject to change without notice.  
 ©2020 SunPower Corporation. All Rights Reserved. SUNPOWER, the SUNPOWER logo, Equinox, and MAXEON are registered trademarks of SunPower Corporation in the U.S. and other countries as well. 1-800-SUNPOWER.

Warranties, Certifications, and Compliance	
Warranties	<ul style="list-style-type: none"> <li>• 25-year limited power warranty</li> <li>• 25-year limited product warranty</li> </ul>
Certifications and Compliance	<ul style="list-style-type: none"> <li>• UL 1703</li> <li>• UL 1741 / IEEE-1547</li> <li>• UL 1741 AC Module (Type 2 fire rated)</li> <li>• UL 62109-1 / IEC 62109-2</li> <li>• FCC Part 15 Class B</li> <li>• ICES-0003 Class B</li> <li>• CAN/CSA-C22.2 NO. 107.1-01</li> <li>• CA Rule 21 (UL 1741 SA)<sup>4</sup> (includes Volt/Var and Reactive Power Priority)</li> <li>• UL Listed PV Rapid Shutdown Equipment<sup>6</sup></li> </ul> <p>Enables installation in accordance with:</p> <ul style="list-style-type: none"> <li>• NEC 690.6 (AC module)</li> <li>• NEC 690.12 Rapid Shutdown (inside and outside the array)</li> <li>• NEC 690.15 AC Connectors, 690.33(A)-(E)(1)</li> </ul> <p>When used with InvisiMount racking and InvisiMount accessories (UL 2703):</p> <ul style="list-style-type: none"> <li>• Module grounding and bonding through InvisiMount</li> <li>• Class A fire rated</li> </ul> <p>When used with AC module Q Cables and accessories (UL 6703 and UL 2238)<sup>6</sup>:</p> <ul style="list-style-type: none"> <li>• Rated for load break disconnect</li> </ul>
PID Test	Potential-induced degradation free

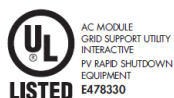
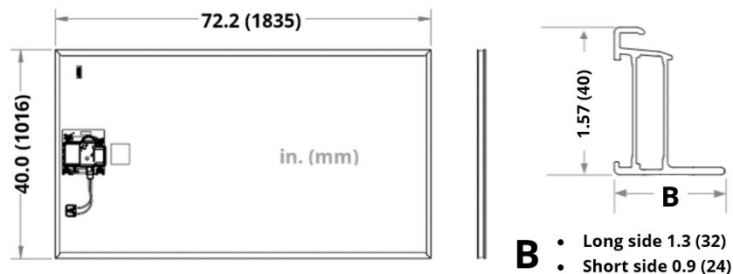

Module Fire Performance: Type 2  
 Please read the Safety and Installation Instructions 532628 for additional details.

SUNPOWER®



# Enphase IQ 7AS Microinverter

The high-powered smart grid-ready **Enphase IQ 7AS Micro™** dramatically simplifies the installation process while achieving the highest system efficiency for systems with 66-cell modules.

Part of the Enphase IQ System, the IQ 7AS Micro integrates with the Enphase IQ Envoy™, Enphase IQ Battery™, and the Enphase Enlighten™ monitoring and analysis software.

The IQ Series Microinverters extend the reliability standards set forth by previous generations and undergo over a million hours of power-on testing, enabling Enphase to provide an industry-leading warranty of up to 25 years.

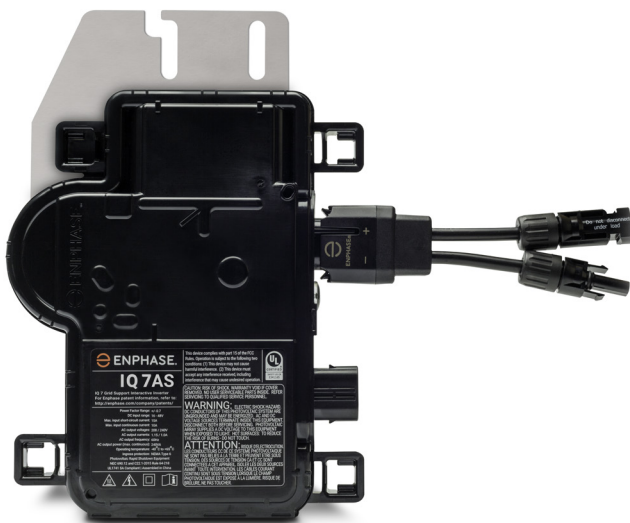

## Easy to Install

- Lightweight and simple
- Faster installation with improved, lighter two-wire cabling
- Built-in rapid shutdown compliant (NEC 2014 & 2017)

## Efficient and Reliable

- Optimized for high powered 66-cell\* modules
- Highest CEC efficiency of 97%
- More than a million hours of testing
- Class II double-insulated enclosure
- UL listed

## Smart Grid Ready

- Complies with advanced grid support, voltage and frequency ride-through requirements
- Remotely updates to respond to changing grid requirements
- Configurable for varying grid profiles
- Meets CA Rule 21 (UL 1741-SA)

\* The IQ 7AS is required to support 66-cell modules.



# Enphase IQ 7AS Microinverter

<b>INPUT (DC)</b>	<b>IQ7AS-66-ACM-US</b>	
Commonly used module pairings <sup>1</sup>	295 W–450 W +	
Module compatibility	66-cell PV modules	
Maximum input DC voltage	58 V	
Peak power tracking voltage <sup>2</sup>	34 V–48 V	
Operating range	18 V–58 V	
Min/Max start voltage	18 V / 58 V	
Max DC short circuit current (module I <sub>sc</sub> )	15 A	
Overvoltage class DC port	II	
DC port backfeed current	0 A	
PV array configuration	1 x 1 ungrounded array; No additional DC side protection required; AC side protection requires max 20A per branch circuit	
<b>OUTPUT (AC)</b>	<b>@ 240 VAC</b>	<b>@ 208 VAC</b>
Peak output power	366 VA	295 VA
Maximum continuous output power	349 VA	290 VA
Nominal (L-L) voltage/range <sup>3</sup>	240 V / 211–264 V	208 V / 183–229 V
Maximum continuous output current	1.45 A (240 VAC)	1.39 A (208 VAC)
Nominal frequency	60 Hz	
Extended frequency range	47–68 Hz	
AC short circuit fault current over 3 cycles	5.8 Arms	
Maximum units per 20 A (L-L) branch circuit <sup>4</sup>	11 (240 VAC)	11 (208 VAC)
Overvoltage class AC port	III	
AC port backfeed current	0 mA	
Power factor setting	1.0	
Power factor (adjustable)	0.85 leading ... 0.85 lagging	
Harmonics (I-THD)	2.57%	
Harmonics (V-THD)	0.03%	
Self-consumption at night	<60mW	
<b>EFFICIENCY</b>	<b>@240 VAC</b>	<b>@208 VAC</b>
CEC weighted efficiency	97%	97%
<b>MECHANICAL</b>		
Ambient temperature range	-40°C to +60°C	
Relative humidity range	4% to 100% (condensing)	
Connector type: DC (IQ7AS-66-ACM-US)	MC4	
Connector type: AC (IQ7AS-66-ACM-US)	MC4	
Dimensions (HxWxD)	212 mm x 175 mm x 30.2 mm (without bracket)	
Weight	1.08 kg (2.38 lbs)	
Cooling	Natural convection – No fans	
Approved for wet locations	Yes	
Pollution degree	PD3	
Enclosure	Class II double-insulated, corrosion resistant polymeric enclosure	
Environmental category / UV exposure rating	NEMA Type 6 / outdoor	
<b>FEATURES</b>		
Communication	Power Line Communication (PLC)	
Monitoring	Enlighten Manager and MyEnlighten monitoring options Compatible with Enphase IQ Envoy	
Disconnecting means	The AC and DC connectors have been evaluated and approved by UL for use as the load-break disconnect required by NEC 690.	
Compliance	CA Rule 21 (UL 1741-SA) UL 62109-1, UL1741/IEEE1547, FCC Part 15 Class B, ICES-0003 Class B, CAN/CSA-C22.2 NO. 107.1-01 This product is UL Listed as PV Rapid Shut Down Equipment and conforms with NEC-2014 and NEC-2017 section 690.12 and C22.1-2015 Rule 64-218 Rapid Shutdown of PV Systems, for AC and DC conductors, when installed according manufacturer's instructions.	

1. No enforced DC/AC ratio. See the compatibility calculator at <https://enphase.com/en-us/support/module-compatibility>.

2. Works for a wider voltage range at lower efficiency.

3. Nominal voltage range can be extended beyond nominal if required by the utility.

4. Limits may vary. Refer to local requirements to define the number of microinverters per branch in your area.

To learn more about Enphase offerings, visit [enphase.com](https://enphase.com)



# SunPower® InvisiMount™ | Residential Mounting System

## Simple and Fast Installation

- Integrated module-to-rail grounding
- Pre-assembled mid and end clamps
- Levitating mid clamp for easy placement
- Mid clamp width facilitates even module spacing
- Simple, pre-drilled rail splice
- UL 2703 Listed integrated grounding

## Flexible Design

- Addresses nearly all sloped residential roofs
- Design in landscape and portrait
- Rails enable easy obstacle management

## Customer-Preferred Aesthetics

- #1 module and #1 mounting aesthetics
- Best-in-class system aesthetics
- Premium, low-profile design
- Black anodized components
- Hidden mid clamps and end clamps hardware, and capped, flush rails

## Part of Superior System

- Built for use with SunPower DC and AC modules
- Best-in-class system reliability and aesthetics
- Combine with SunPower modules and monitoring app



## Elegant Simplicity

SunPower® InvisiMount™ is a SunPower-designed rail-based mounting system. The InvisiMount system addresses residential sloped roofs and combines faster installation time, design flexibility, and superior aesthetics. The InvisiMount product was specifically envisioned and engineered to pair with SunPower modules. The resulting system-level approach will amplify the aesthetic and installation benefits for both homeowners and installers.

[sunpower.com](http://sunpower.com)



SUNPOWER®



# SunPower® InvisiMount™ | Residential Mounting System

## InvisiMount Component Images

Module\* / Mid Clamp and Rail

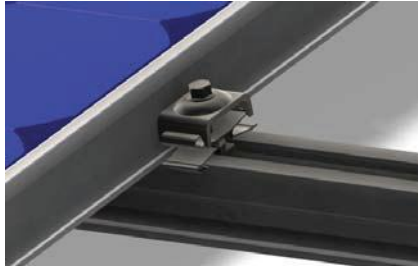

Module\* / End Clamp and Rail

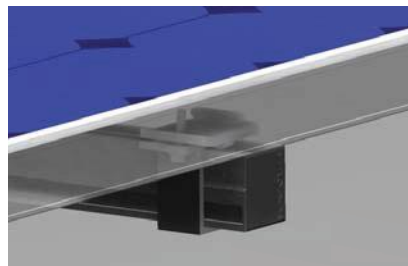

Mid Clamp



End Clamp



Rail & Rail Splice



Ground Lug Assembly



End Cap



InvisiMount Component Details		
Component	Material	Weight
Mid Clamp	Black oxide stainless steel AISI 304	63 g (2.2 oz)
End Clamp	Black anodized aluminum alloy 6063-T6	110 g (3.88 oz)
Rail	Black anodized aluminum alloy 6005-T6	830 g/m (9 oz/ft)
Rail Splice	Aluminum alloy 6005-T5	830 g/m (9 oz/ft)
Ground Lug Assembly	304 stainless (A2-70 bolt; tin-plated copper lug)	106.5 g/m (3.75 oz)
End Cap	Black acetal (POM) copolymer	10.4 g (0.37 oz)

InvisiMount Operating Conditions	
Temperature	-40° C to 90° C (-40° F to 194° F)
Max. Load	2400 Pa uplift 5400 Pa downforce

InvisiMount Warranties And Certifications	
Warranties	25-year product warranty 5-year finish warranty
Certifications	UL 2703 Listed Class A fire rating when distance between roof surface and bottom of SunPower module frame is ≤ 3.5"

Roof Attachment Hardware Supported by InvisiMount System Design Tool	
Application	<ul style="list-style-type: none"> <li>• Composition Shingle Rafter Attachment</li> <li>• Composition Shingle Roof Decking Attachment</li> <li>• Curved and Flat Tile Roof Attachment</li> <li>• Universal Interface for Other Roof Attachments</li> </ul>

Roof Attachment Hardware Warranties	
Refer to roof attachment hardware manufacturer's documentation	

\*Module frame that is compatible with the InvisiMount system required for hardware interoperability.

© 2015 SunPower Corporation. All Rights Reserved. SUNPOWER, the SUNPOWER logo, and INVISIMOUNT are trademarks or registered trademarks of SunPower Corporation. All other trademarks are the property of their respective owners. Specifications included in this datasheet are subject to change without notice.

## Eaton general duty non-fusible safety switch

**DG222URB-CSA**

**UPC:786685223131**

### **Dimensions:**

- **Height:** 14.38 IN
- **Length:** 7.38 IN
- **Width:** 8.69 IN

**Weight:**9 LB

### **Warranties:**

- Eaton Selling Policy 25-000, one (1) year from the date of installation of the Product or eighteen (18) months from the date of shipment of the Product, whichever occurs first.

### **Specifications:**

- **Special Features:** CSA Certified
- **Type:** Non-fusible, single-throw
- **Amperage Rating:** 60A
- **Enclosure:** NEMA 3R, Rainproof
- **Enclosure Material:** Painted galvanized steel
- **Fuse Configuration:** Non-fusible
- **Number Of Poles:** Two-pole
- **Number Of Wires:** Two-wire
- **Product Category:** General duty safety switch
- **Voltage Rating:** 240V

### **Supporting documents:**

- [Eaton Specification Sheet - DG222URB-CSA](#)

### **Certifications:**

- CSA Certified

**Product compliance:** No Data

