

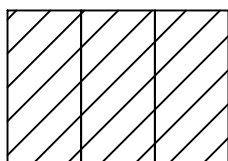

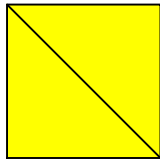



THIS DISTRIBUTED GENERATION FACILITY WAS INSTALLED
IN ACCORDANCE WITH THE CURRENT STATE ADOPTED
NATIONAL ELECTRICAL CODE

DESIGN SUMMARY

- **SIZE:** 8.640 kW PV Solar System (24 modules)
- **STYLE:** Residential, asphalt shingle roof, flush mount, grid tied, net-metered
- **LOCATION:** Southeast facing roof of home
- **ORIENTATION:** Portrait, 40° pitch, 108° azimuth
- **MODULE:** SunPower X22-360 360W, with Factory integrated microinverter, 61.3"x 41.2"x 1.8" thick, 41 lbs
- **RACKING:** SunPower Invisimount with asphalt shingle roof flashings
- **INVERTER:** SunPower Type E (IQ7XS) Microinverter
- **VOLTAGE:** 120/240V, 1Φ
- **MONITORING:** Online mySunPower Monitoring
- **ADDITIONAL WORK:** None

-  **PV Solar Array**
Roof of building
-  **Enphase Microinverter**
Array
-  **PV Solar Dedicated Load Center**
Building Exterior
-  **AC Solar Disconnect**
Building Exterior
-  **Main Service Panel**
Building Interior
(Garage Wall)
-  **Utility Meter**
Building Exterior
-  **Lockable Tap Box**
Building Exterior
-  **Existing Air Conditioner Unit**
Building Exterior

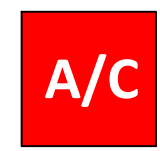
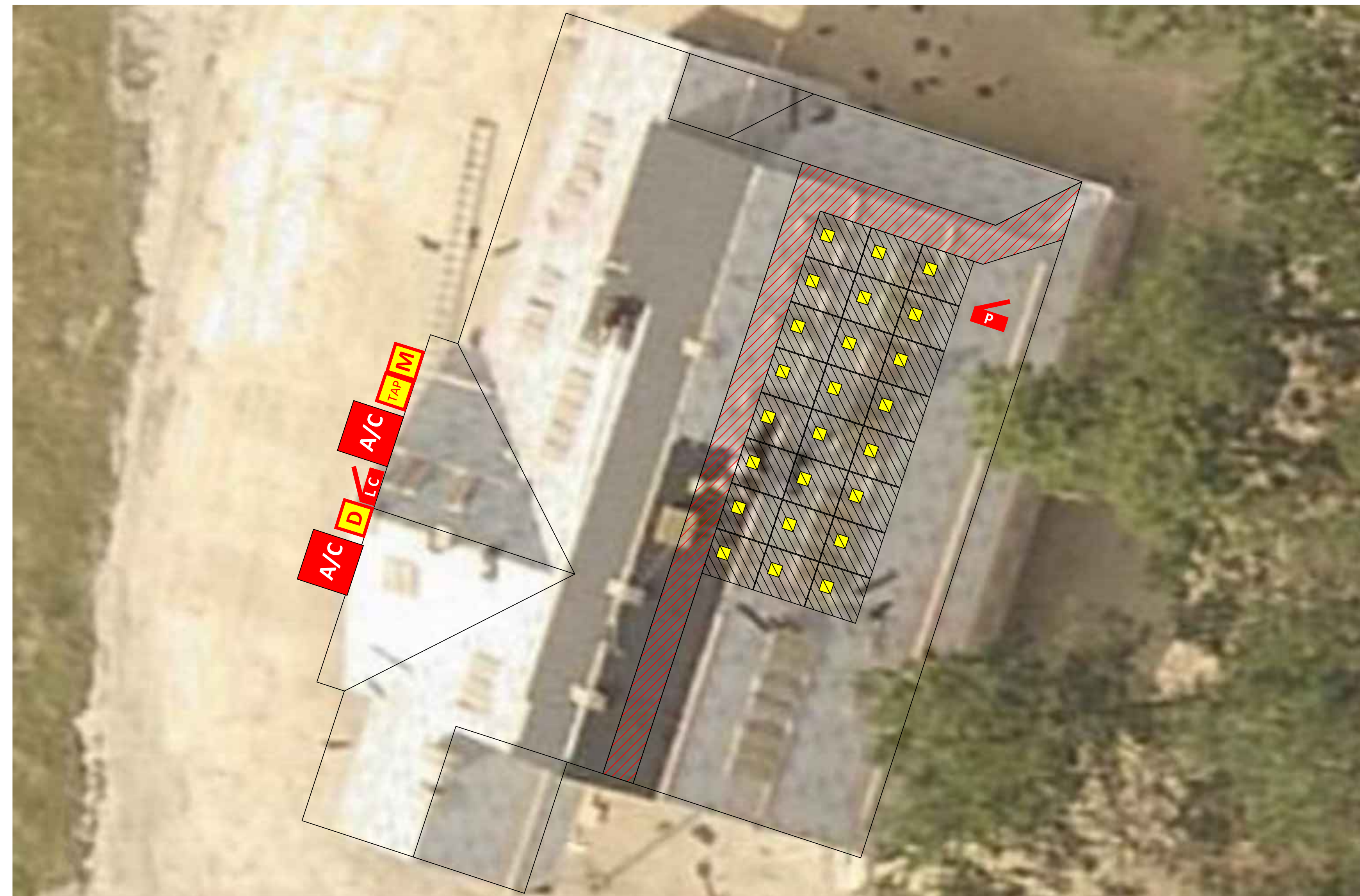

CONTRACTOR

MOXIE SOLAR

(855) 669-4387
INFO@MOXIESOLAR.COM
323 W CHERRY ST
NORTH LIBERTY, IA 52317

OWNER

AUSTIN LILLY

(704) 317-9340
AU.CORBINLILLY@GMAIL.COM
3641 RAWLS CHURCH RD
FUQUAY VARINA, NC 27526

A H J

HARNETT COUNTY

(108) 893-7525
108 E FRONT ST
LILLINGTON, NC 27546

UTILITY

DUKE ENERGY

(844) 388-7425

REVISIONS

06/11/21	PLAN SET	KK
06/18/21	REV 1	LG

DESIGN SUMMARY

BUILD SUMMARY

- **MODULE:** QTY (24) X22-360 360W, 61.3"x 41.2"x 1.8" thick, 41 lbs
- **STRUCTURE:** Wood prefabricated 2"x 8" trusses @ 16" OC
- **RACKING:** SunPower Invisimount with asphalt shingle roof flashing. Run rails across the trusses. Penetrate every 4ft or less into trusses. Installer must verify all penetrations are secure and centered in wood members. Any damaged wood members must be repaired immediately by scab, sister, or full replacement. Max Rail Overhang = 19" from last attachment point. Module Overhang = 18"
- **ACCESS:** 2-story residence
- **INVERTERS:** Factory integrated microinverters at modules.
- **MONITORING:** Online mySunPower Monitoring utilizing existing wireless router
- **ADDITIONAL WORK:** None

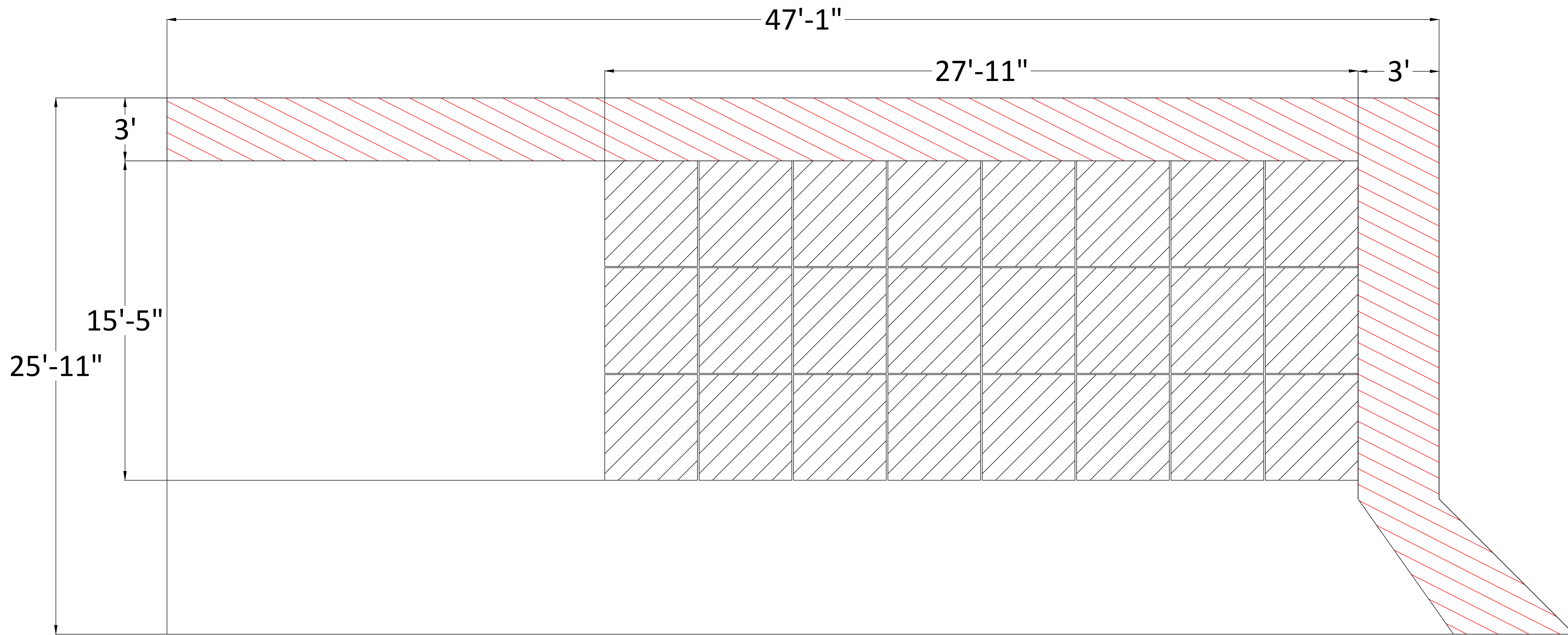

CONTRACTOR

MOXIE SOLAR

(855) 669-4387
INFO@MOXIESOLAR.COM
323 W CHERRY ST
NORTH LIBERTY, IA 52317

OWNER

AUSTIN LILLY

(704) 317-9340
AU.CORBINLILLY@GMAIL.COM
3641 RAWLS CHURCH RD
FUQUAY VARINA, NC 27526

A H J

HARNETT COUNTY

(108) 893-7525
108 E FRONT ST
LILLINGTON, NC 27546

UTILITY

DUKE ENERGY

(844) 388-7425

REVISIONS

06/11/21	PLAN SET	KK
06/18/21	REV 1	LG

BUILD SUMMARY

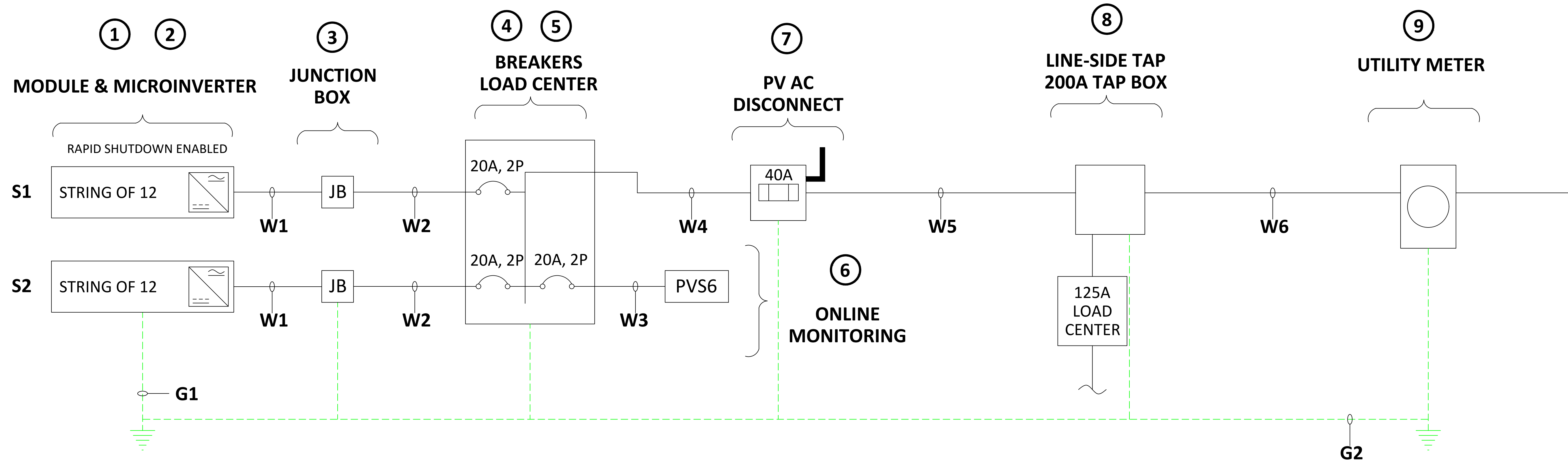

1 ONE-LINE ELECTRICAL DIAGRAM - 8.640 KW (DC)
03 NO SCALE

EQUIPMENT SCHEDULE						
TAG	ITEM	MAKE	MODEL	VOLTAGE	QTY	LOCATION
1	MODULE	SUNPOWER	X22-360 360W	DC	24	ROOF TOP
2	MICROINVERTER	SUNPOWER	TYPE E (IQ7XS) 315W (AC)	120/240V, 1Φ	24	ROOF TOP
3	JUNCTION BOX	VYNCKIER	RJ1	120/240V, 1Φ	2	ROOF TOP
4	BREAKERS	EATON	20A, 2-POLE BR220	120/240V, 1Φ	3	LOAD CENTER
5	LOAD CENTER	EATON	125A ENCLOSURE LUG ONLY BR816L125RP	120/240V, 1Φ	1	BLD EXTERIOR
6	ONLINE MONITORING	SUNPOWER	PV SUPERVISOR 6	120/240V, 1Φ	1	BLD EXTERIOR
7	DISCONNECT	EATON	60A ENCLOSURE 40A FUSED DG222NRB	120/240V, 1Φ	1	BLD EXTERIOR
8	LINE-SIDE TAP BOX	MILBANK	200A, 2 -POLE U4540XL	120/240V, 1Φ	1	MAIN PANEL
9	UTILITY METER	ITRON	CL200	120/240V, 1Φ	1	BLD EXTERIOR

WIRE SCHEDULE					
TAG	RUN	CONDUCTOR TYPE	GAUGE	CONDUIT	RUN LENGTH
W1	PV HOMERUNS	Q-CABLE Q-12-10-240-PORT	#12	-	60 FT
W2	JUNCTION BOX TO LOAD CENTER	THWN-2, Cu	#10	3/4"	30 FT
W3	LOAD CENTER TO PVS6	THWN-2, Cu	#12	1/2"	5 FT
W4	LOAD CENTER TO DISCONNECT	THWN-2, Cu	#8	1"	5 FT
W5	DISCONNECT TO TAP BOX	THWN-2, Cu	#8	1"	15FT
W6	TAP BOX TO UTILITY METER	THWN-2, Cu	#3/0	1 1/2"	5 FT
G1	GROUND ELECTRODE	BARE, Cu	#6	-	-
G2	EQUIPMENT GROUND (as per NEC 250.122)	THWN-2, Cu	#10 - #6	-	100 FT

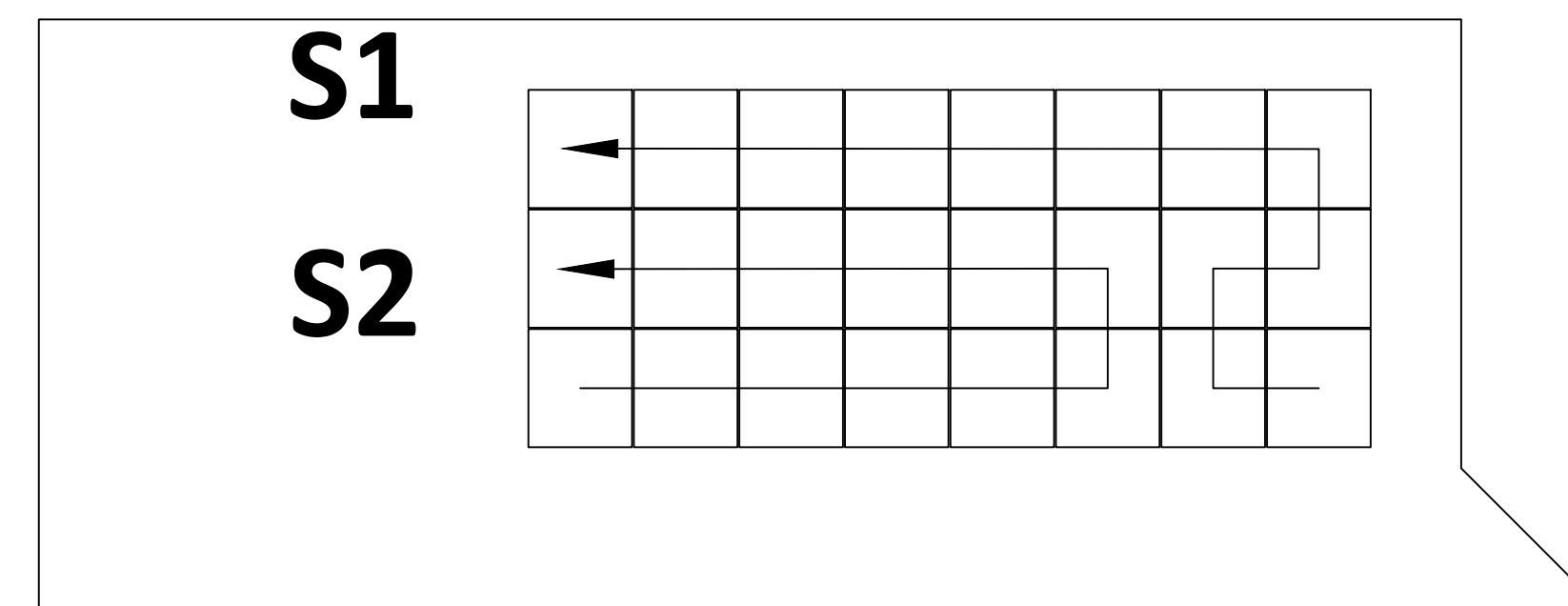

CONTRACTOR

MOXIE SOLAR

(855) 669-4387
INFO@MOXIESOLAR.COM

323 W CHERRY ST
NORTH LIBERTY, IA 52317

OWNER

AUSTIN LILLY

(704) 317-9340
AU.CORBINLILLY@GMAIL.COM

3641 RAWLS CHURCH RD
FUQUAY VARINA, NC 27526

A H J

HARNETT COUNTY

(108) 893-7525

108 E FRONT ST
LILLINGTON, NC 27546

UTILITY

DUKE ENERGY

(844) 388-7425

REVISIONS

06/11/21 PLAN SET KK

06/18/21 REV 1 LG

ELECTRICAL

03

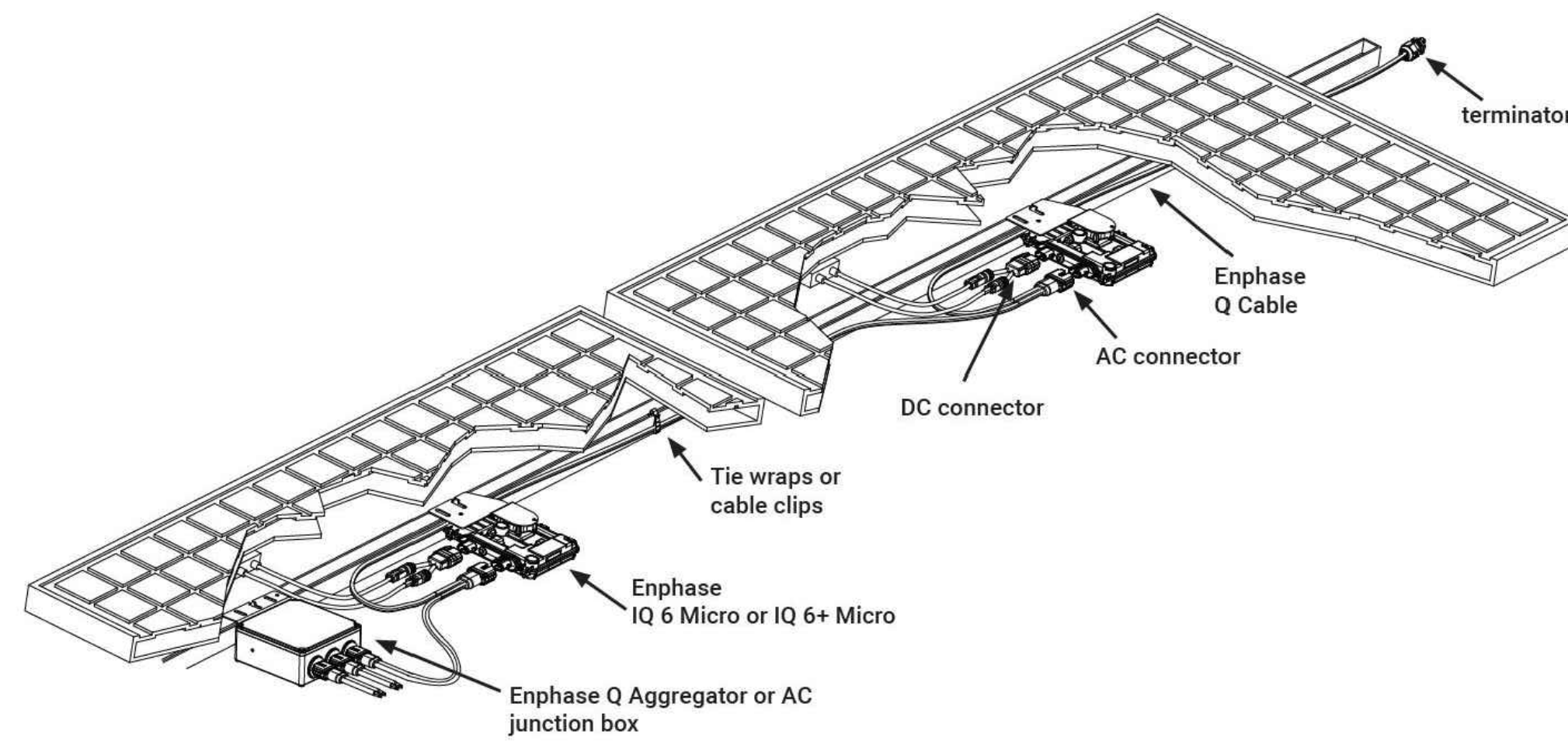

1
04 MODULE AND MICROINVERTER CONNECTION DETAIL
NO SCALE



2
04 SUNPOWER INVISIMOUNT ROOF FLASHING DETAIL
NO SCALE

SYSTEM AC DISCONNECT AT SERVICE

PHOTOVOLTAIC SYSTEM AC DISCONNECT
 MAXIMUM OPERATING AC CURRENT: 31.44 AMPS
 NOMINAL OPERATING AC VOLTAGE: 120/240 VAC

3
04 PHOTOVOLTAIC MARKING AND LABELING
NO SCALE

CODE REVIEW & CALCULATIONS

SOLAR PHOTOVOLTAIC (PV) SYSTEM WITH SUNPOWER

Inverter Type: SunPower Type E (IQ7XS) Factory Integrated MicroInverter
 Minimum String Length: N/A
 Maximum String Length: 12
 Nominal String AC Voltage: 240V (AC)
 Nominal Output Current (Per MicroInverter): 1.31A

SunPower X22-360 360W

NEC 690.7 MAXIMUM VOLTAGE

690.7(A): Maximum Photovoltaic System Voltage
 X22-360 360W Module $V_{oc} = 69.50V$
 Module $V_{max} = ((-40^{\circ}C) - 25^{\circ}C)(-0.0029/^{\circ}C)(69.50V) + (69.50V) = 82.60V$ (DC)
 Module V_{max} Output = 82.60V (DC) < IQ7X MAX Input = 80V (DC)

NEC 690.8 CIRCUIT SIZING AND CURRENT

690.8(A)(1): Photovoltaic Source Circuit Currents
 Module to MicroInverter $I_{max} = 1.31A \times 24 \times 125\% = 39.30A$

690.8(A)(3): Inverter Output Circuit Current.
 MicroInverter Rated Continuous Output Power = 315W
 MicroInverter rated Continuous Output Current = 1.31A
 System $I_{max} = 39.30A$

NEC 690.9 OVERCURRENT PROTECTION

690.9(B): Overcurrent Device Ratings
 Disconnect Fuse: $1.31A \times 24 \times 125\% = 39.30A \rightarrow 40A$ OCPD

NEC 690.12 RAPID SHUTDOWN OF PV SYSTEMS ON BUILDINGS

PLAN: Rapid Shutdown enabled disconnect shall be located next to the service and be labeled in accordance with 690.56(B) and (C).



CONTRACTOR

MOXIE SOLAR

(855) 669-4387
 INFO@MOXIESOLAR.COM

323 W CHERRY ST
 NORTH LIBERTY, IA 52317

OWNER

AUSTIN LILLY

(704) 317-9340
 AU.CORBINLILLY@GMAIL.COM

3641 RAWLS CHURCH RD
 FUQUAY VARINA, NC 27526

A H J

HARNETT COUNTY

(108) 893-7525

108 E FRONT ST
 LILLINGTON, NC 27546

UTILITY

DUKE ENERGY

(844) 388-7425

REVISIONS

06/11/21 PLAN SET KK

06/18/21 REV 1 LG

DETAILS & CALCULATIONS

Roof Assessment for Solar Panel Installation

Date: July 12, 2021
Prepared for: C&S Lilly 24pR
Project Number: 210559
Assessment Date: July 12, 2021
Site Address: 3641 Rawls Church Rd Fuquay-Varina NC 27526
Purpose: Structural Roof Assessment for installation of 24 panel solar array.
Prepared by: Landon Wilson & Clay Medlin, PE, NC #048735
NC COL: C-3298, CDR & Assoc., Inc.



CDR & Assoc., Inc. thanks you for the opportunity to provide you with a letter for the inspection of the roof framing for the installation of solar panel system on the roof of the foresaid property hereafter referred to as "house". All references to directions or locations indicated in this report are by facing the front of the house.

Observations and Analysis of Roof

- **Basis of Evaluation:** The engineering analysis is based on measurements and photographs taken onsite by CDR+A technician, Brady Jarvis.
- **Roof Construction:** A asphalt shingles roof over wood decking on 2x8 rafters at 16" o.c.
- **Roof Pitch:** Multiple pitches
- **Solar Panel Array:** 24 panels.
- **Total Array Square Footage:** The panels are approximately 39.37" x 64.57" or 17.65 sf each, round up to 18 sf x 24 panels = total surface area of 432 sf.
- **Total weight of Array:** Panel weighs approximately 40 lbs. ea. X 24 = 960 lbs. for the Array.
- **Total Additional Weight on Roof:** 960 lbs / 432 sf = 2.22 psf add for rail mount system, assume 3 psf additional load on roof structure.
- **Rail Mount System:** The panels are mounted on aluminum rails at top and bottom of the panels for each row of panels.

- **Analysis of Roof Structure:**

- Additional dead load 15 psf (12 psf from roof + 3 psf for panels)
 - Roof Live Load - 20 psf. (Allowable Residential Code w/o reductions)
 - The 2x8 SYP Rafters spaced 16" apart were analyzed (worst case).
 - Roof Pitch 9.8/12
 - The maximum unbraced span: 14' 5" measured horizontal.
 - Analysis with the additional roof load determined that the roof Rafters are 88% stressed. The Rafters are in compliance with the current Residential Building Code.
- **Wind Speed:** Components and cladding 116 mph wind load uplift of -30 psf.
 - **Total Wind Load Uplift:** -30 psf x 432 sf = 12,960 lbs total uplift for solar array.
 - **Number of Attachment Anchors:** Use a minimum of two (2) bracket per panel (one top and bottom) or less to meet rail manufacturers recommended support needs = 48 total attachment brackets.
 - **Wind Load Uplift per Anchor:** 12,960 lbs total uplift / 48 = 270 lbs for solar array.
 - **Strength of Hold-down Anchors:** Pegasus Solar® L-Foot the SunPower InvisiMount is reported to be used with the Pegasus Solar L-Foot. The L-Foot is attached directly into the top of the rafter members with 5/16" stainless steel lag screw with at least 3" of embedment into the wood member. The load testing results determined an average pullout failure load of 556 lbs per screw, exceeding the required 270 lbs per anchor. The loading proposed creates a safety factor of 2.05 or greater for the attachment.

Conclusions & Recommendations

By analysis it was determined that the roof rafter members were adequate for the addition load of the solar panel array.

The installation of the solar panel array using the Pegasus Solar® L-Foot attachment bracket directly to the top of the wood members with one 5/16" stainless steel lag screw per manufacturers spec. is adequate for the loads imposed on them.

Closure

We appreciate the opportunity to provide structural assessment services to you. Please contact us should you have any questions.

Sincerely,

CDR+A Structural Engineers

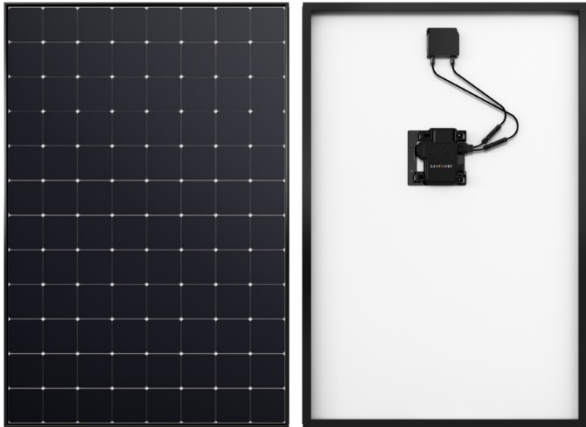

SunPower® X-Series: X22-370 | X22-360

SunPower® Residential AC Module

Built specifically for use with the SunPower Equinox™ system, the only fully integrated solution designed, engineered, and warranted by one manufacturer.



Maximum Power. Minimalist Design.

Industry-leading efficiency means more power and savings per available space. With fewer modules required and hidden microinverters, less is truly more.



Highest Lifetime Energy and Savings.

Designed to deliver 60% more energy over 25 years in real-world conditions like partial shade and high temperatures.¹

Fundamentally Different. And Better.

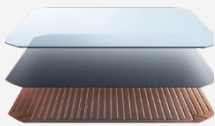

The SunPower® Maxeon® Solar Cell

- Enables highest-efficiency modules available²
- Unmatched reliability³
- Patented solid metal foundation prevents breakage and corrosion



Factory-integrated Microinverter

- Simpler, faster installation
- Integrated wire management, rapid shutdown
- Engineered and calibrated by SunPower for SunPower modules

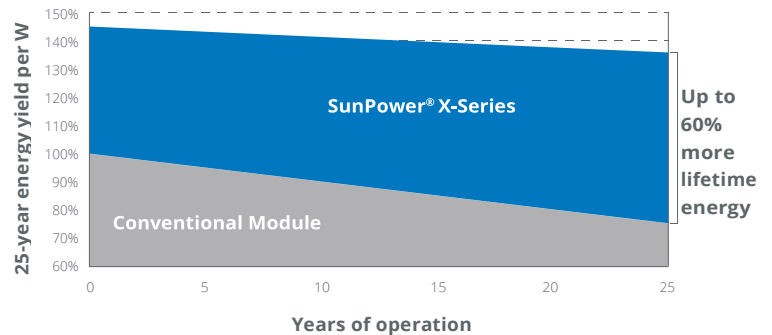

Best Reliability. Best Warranty.

With more than 25 million modules deployed around the world, SunPower technology is proven to last. That's why we stand behind our module and microinverter with the industry's best 25-year Combined Power and Product Warranty, including the highest Power Warranty in solar.

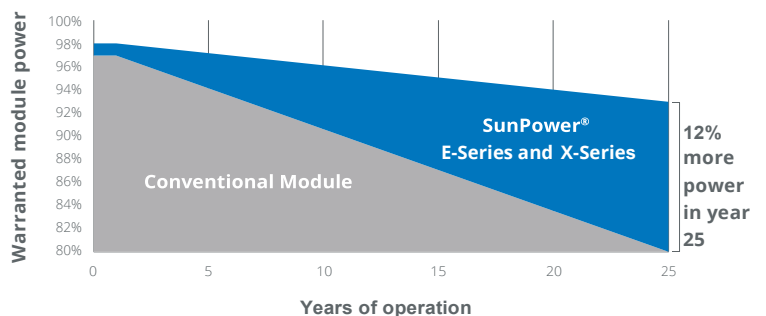

AC Electrical Data	
Inverter Model: Type E (IQ 7XS)	@240 VAC
Peak Output Power	320 VA
Max. Continuous Output Power	315 VA
Nom. (L-L) Voltage/Range ² (V)	240 / 211–264
Max. Continuous Output Current (A)	1.31
Max. Units per 20 A (LL) Branch Circuit ³	12 (single phase)
CEC Weighted Efficiency	97.5%
Nom. Frequency	60 Hz
Extended Frequency Range	47–68 Hz
AC Short Circuit Fault Current Over 3 Cycles	5.8 A rms
Overvoltage Class AC Port	III
AC Port Backfeed Current	18 mA
Power Factor Setting	1.0
Power Factor (adjustable)	0.7 lead. / 0.7 lag.
No active phase balancing for three-phase installations	

DC Power Data		
	SPR-X22-370-E-AC	SPR-X22-360-E-AC
Nominal Power ⁵ (P _{nom})	370 W	360 W
Power Tolerance	+5/-0%	+5/-0%
Module Efficiency ⁵	22.7%	22.1%
Temp. Coef. (Power)	-0.29%/°C	-0.29%/°C
Shade Tolerance	<ul style="list-style-type: none"> • Three bypass diodes • Integrated module-level maximum power point tracking 	

Tested Operating Conditions	
Operating Temp.	-40°F to +185°F (-40°C to +85°C)
Max. Ambient Temp.	122°F (50°C)
Max. Test Load ⁷	Wind: 154 psf, 7400 Pa, 754 kg/m ² back Snow: 208 psf, 10000 Pa, 1019 kg/m ² front
Design Load	Wind: 62 psf, 3000 Pa, 305 kg/m ² back Snow: 125 psf, 6000 Pa, 611 kg/m ² front
Impact Resistance	1 inch (25 mm) diameter hail at 52 mph (23 m/s)

Mechanical Data	
Solar Cells	96 Monocrystalline Maxeon Gen III
Front Glass	High-transmission tempered glass with anti-reflective coating
Environmental Rating	Module: Outdoor rated Inverter: NEMA Type 6 Class II
Frame	Class 1 black anodized (highest AAMA rating)
Weight	42.9 lb (19.5 kg)
Recommended Max. Module Spacing	1.3 in. (33 mm)

1 SunPower 360 W compared to a conventional module on same-sized arrays (260 W, 16% efficient, approx. 1.6 m²), 4% more energy per watt (based on third-party module characterization and PVSim), 0.75%/yr slower degradation (Campeau, Z. et al. "SunPower Module Degradation Rate," SunPower white paper, 2013).
 2 Based on search of datasheet values from websites of top 10 manufacturers per IHS, as of January 2017.
 3 #1 rank in "Fraunhofer PV Durability Initiative for Solar Modules: Part 3," PV Tech Power Magazine, 2015.
 4 Factory set to 1547a-2014 default settings. CA Rule 21 default settings profile set during commissioning.
 5 Standard Test Conditions (1000 W/m² irradiance, AM 1.5, 25°C). NREL calibration standard: SOMS current, LACCS FF and voltage. All DC voltage is fully contained within the module.
 6 This product is UL Listed as PVRE and conforms with NEC 2014 and NEC 2017 690.12; and C22.1-2015 Rule 64-218 Rapid Shutdown of PV Systems, for AC and DC conductors; when installed according to manufacturer's instructions.
 7 Please read the safety and installation instructions for more information regarding load ratings and mounting configurations.

See www.sunpower.com/facts for more reference information.
 For more details, see extended datasheet www.sunpower.com/datasheets Specifications included in this datasheet are subject to change without notice.
 ©2020 SunPower Corporation. All Rights Reserved. SUNPOWER, the SUNPOWER logo and MAXEON are registered trademarks of SunPower Corporation in the U.S. and other countries as well. 1-800-SUNPOWER.

Warranties, Certifications, and Compliance	
Warranties	<ul style="list-style-type: none"> • 25-year limited power warranty • 25-year limited product warranty
Certifications and Compliance	<ul style="list-style-type: none"> • UL 1703 • UL 1741 / IEEE-1547 • UL 1741 AC Module (Type 2 fire rated) • UL 62109-1 / IEC 62109-2 • FCC Part 15 Class B • ICES-0003 Class B • CAN/CSA-C22.2 NO. 107.1-01 • CA Rule 21 (UL 1741 SA)⁴ • (includes Volt/Var and Reactive Power Priority) • UL Listed PV Rapid Shutdown Equipment⁶ <p>Enables installation in accordance with:</p> <ul style="list-style-type: none"> • NEC 690.6 (AC module) • NEC 690.12 Rapid Shutdown (inside and outside the array) • NEC 690.15 AC Connectors, 690.33(A)-(E)(1) <p>When used with InvisiMount racking and InvisiMount accessories (UL 2703):</p> <ul style="list-style-type: none"> • Module grounding and bonding through InvisiMount • Class A fire rated <p>When used with AC module Q Cables and accessories (UL 6703 and UL 2238)⁶:</p> <ul style="list-style-type: none"> • Rated for load break disconnect
PID Test	Potential-induced degradation free

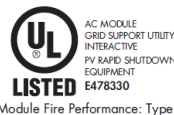
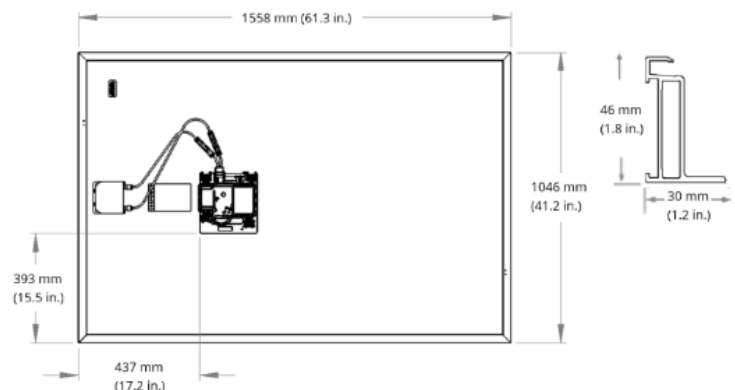

SUNPOWER®

Please read the Safety and Installation Instructions for details.

531945 RevC

SunPower® InvisiMount™ | Residential Mounting System

Simple and Fast Installation

- Integrated module-to-rail grounding
- Pre-assembled mid and end clamps
- Levitating mid clamp for easy placement
- Mid clamp width facilitates even module spacing
- Simple, pre-drilled rail splice
- UL 2703 Listed integrated grounding

Flexible Design

- Addresses nearly all sloped residential roofs
- Design in landscape and portrait
- Rails enable easy obstacle management

Customer-Preferred Aesthetics

- #1 module and #1 mounting aesthetics
- Best-in-class system aesthetics
- Premium, low-profile design
- Black anodized components
- Hidden mid clamps and end clamps hardware, and capped, flush rails

Part of Superior System

- Built for use with SunPower DC and AC modules
- Best-in-class system reliability and aesthetics
- Combine with SunPower modules and monitoring app



Elegant Simplicity

SunPower® InvisiMount™ is a SunPower-designed rail-based mounting system. The InvisiMount system addresses residential sloped roofs and combines faster installation time, design flexibility, and superior aesthetics. The InvisiMount product was specifically envisioned and engineered to pair with SunPower modules. The resulting system-level approach will amplify the aesthetic and installation benefits for both homeowners and installers.

sunpower.com



SUNPOWER®



SunPower® InvisiMount™ | Residential Mounting System

InvisiMount Component Images

Module* / Mid Clamp and Rail

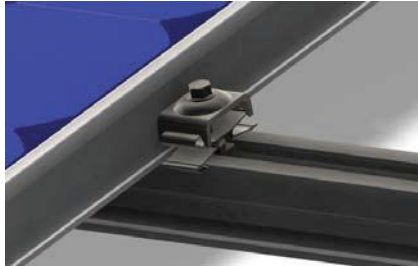

Module* / End Clamp and Rail

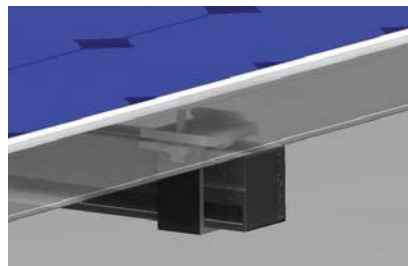

Mid Clamp



End Clamp



Rail & Rail Splice



Ground Lug Assembly



End Cap



InvisiMount Component Details		
Component	Material	Weight
Mid Clamp	Black oxide stainless steel AISI 304	63 g (2.2 oz)
End Clamp	Black anodized aluminum alloy 6063-T6	110 g (3.88 oz)
Rail	Black anodized aluminum alloy 6005-T6	830 g/m (9 oz/ft)
Rail Splice	Aluminum alloy 6005-T5	830 g/m (9 oz/ft)
Ground Lug Assembly	304 stainless (A2-70 bolt; tin-plated copper lug)	106.5 g/m (3.75 oz)
End Cap	Black acetal (POM) copolymer	10.4 g (0.37 oz)

InvisiMount Operating Conditions	
Temperature	-40° C to 90° C (-40° F to 194° F)
Max. Load	2400 Pa uplift 5400 Pa downforce

InvisiMount Warranties And Certifications	
Warranties	25-year product warranty 5-year finish warranty
Certifications	UL 2703 Listed Class A fire rating when distance between roof surface and bottom of SunPower module frame is ≤ 3.5"

Roof Attachment Hardware Supported by InvisiMount System Design Tool	
Application	<ul style="list-style-type: none"> • Composition Shingle Rafter Attachment • Composition Shingle Roof Decking Attachment • Curved and Flat Tile Roof Attachment • Universal Interface for Other Roof Attachments

Roof Attachment Hardware Warranties	
Refer to roof attachment hardware manufacturer's documentation	

*Module frame that is compatible with the InvisiMount system required for hardware interoperability.

© 2015 SunPower Corporation. All Rights Reserved. SUNPOWER, the SUNPOWER logo, and INVISIMOUNT are trademarks or registered trademarks of SunPower Corporation. All other trademarks are the property of their respective owners. Specifications included in this datasheet are subject to change without notice.