

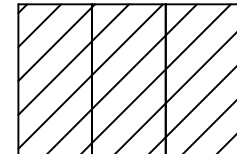

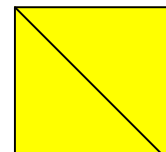

THIS DISTRIBUTED GENERATION FACILITY WAS INSTALLED IN ACCORDANCE WITH THE CURRENT STATE ADOPTED NATIONAL ELECTRICAL CODE

DESIGN SUMMARY

- **SIZE:** 7.38 kW PV Solar System (18 modules)
- **STYLE:** Residential, metal roof, flush mount, grid tied, net-metered
- **LOCATION:** South facing roof of home
- **ORIENTATION:** Portrait, 14° & 5° pitch, 214° azimuth
- **MODULE:** Sunpower SPR-A410, 72.2"x 40"x 1.57" thick, 44 lbs
- **RACKING:** SunPower Invisimount Series with S-5! Solar Foot metal roof flashings
- **INVERTER:** Enphase IQ7X MicroInverters
- **VOLTAGE:** 120/240V, 1Φ
- **MONITORING:** Online mySunPower Monitoring
- **ADDITIONAL WORK:** None

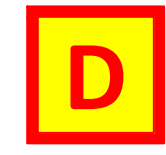
-  **PV Solar Array**
Roof of building
-  **Enphase Microinverter Array**
-  **PV Solar Dedicated Load Center**
Building Exterior
-  **AC Solar Disconnect**
Building Exterior
-  **Main Service Panel**
Building Interior
-  **Utility Meter**
Building Exterior

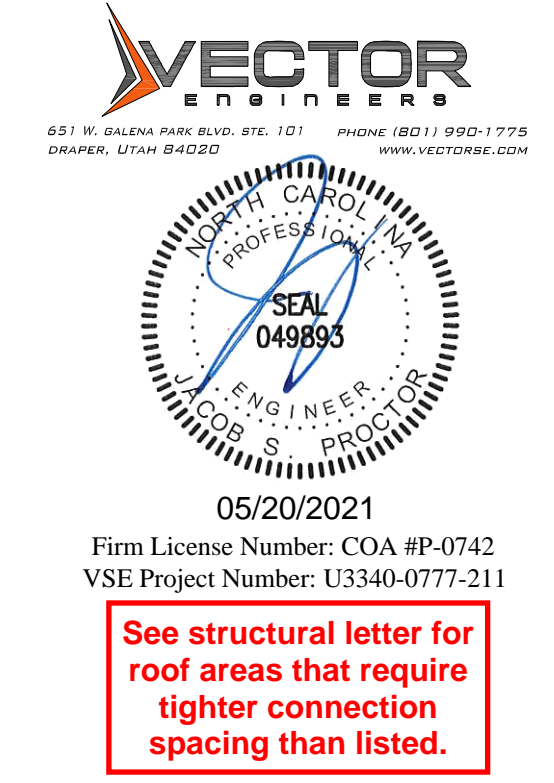

CONTRACTOR

MOXIE SOLAR
(855) 669-4387
INFO@MOXIESOLAR.COM
323 W CHERRY ST
NORTH LIBERTY, IA 52317

OWNER

DAVID STRICKLAND
(910) 591-7149
strickd@hotmail.com
342 E Jackson Blvd #A
Erwin, NC 28339

A H J

TOWN OF ERWIN

(910) 897-5140
P.O. BOX 459
ERWIN, NC 28339

UTILITY

DUKE ENERGY
(844) 388-7425

REVISIONS

04/22/21 PLAN SET JPM

DESIGN SUMMARY

BUILD SUMMARY

- **MODULE:** QTY (18) SPR-A410, 72.2"x 40"x 1.57" thick, 44 lbs
- **STRUCTURE:** Wood 2"x 4" rafters @ 16" OC
- **RACKING:** SunPower Invisimount series with S-5! SolarFoot metal roof flashing. Run rails across the trusses. Penetrate every 2.7ft or less into trusses. Installer must verify all penetrations are secure and centered in wood members. Any damaged wood members must be repaired immediately by scab, sister, or full replacement.
Max Rail Overhang = 19" from last attachment point. Module Overhang = 18"
- **ACCESS:** 1-story residence
- **INVERTERS:** Mount microinverters at module locations
- **MONITORING:** Online mySunPower Monitoring utilizing existing wireless router
- **ADDITIONAL WORK:** None

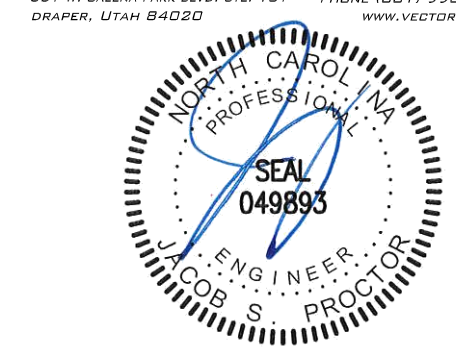

05/20/2021
Firm License Number: COA #P-0742
VSE Project Number: U3340-0777-211

See structural letter for roof areas that require tighter connection spacing than listed.

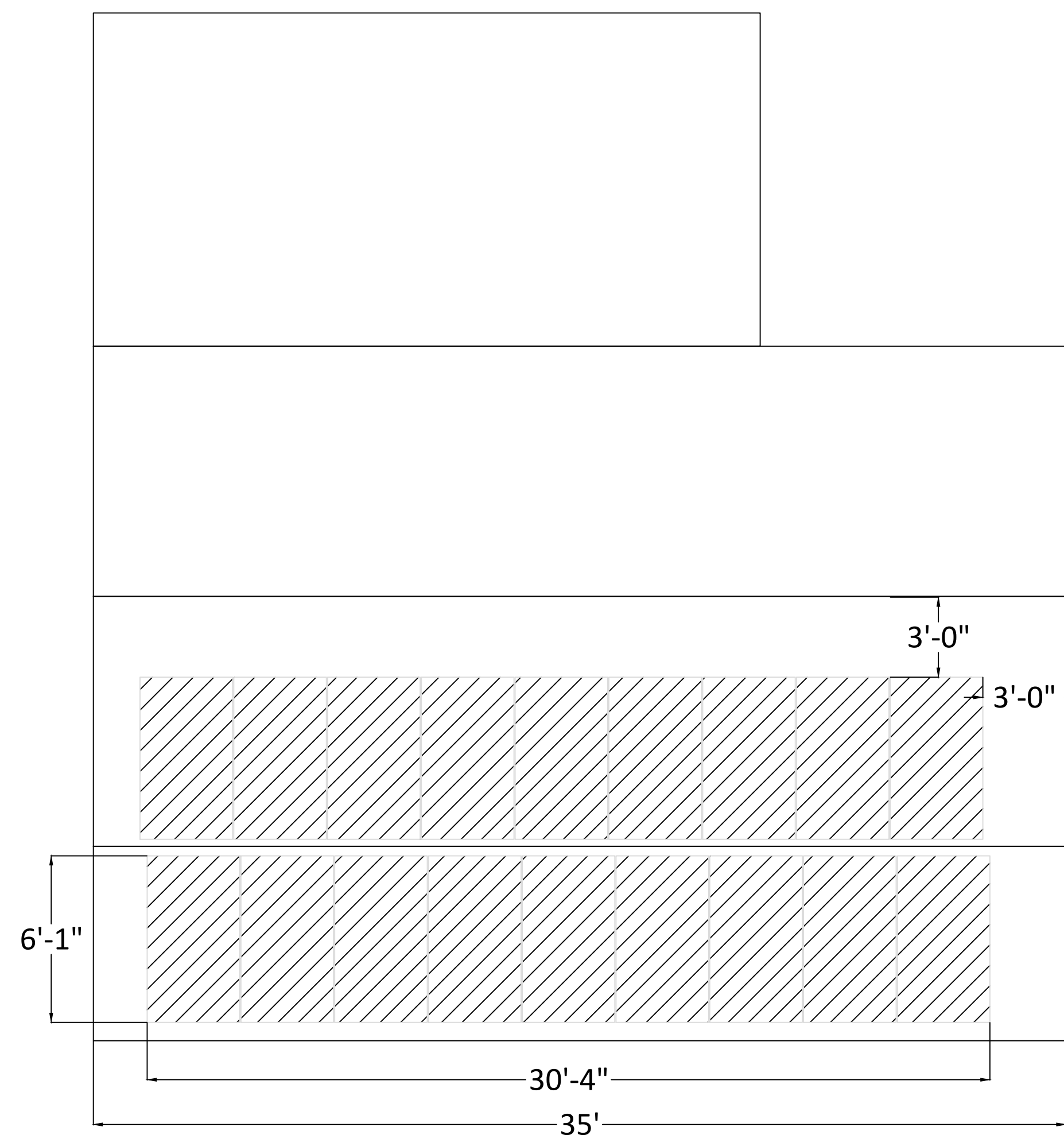

CONTRACTOR

MOXIE SOLAR

(855) 669-4387
INFO@MOXIESOLAR.COM
323 W CHERRY ST
NORTH LIBERTY, IA 52317

OWNER

DAVID STRICKLAND

(910) 591-7149
strickd@hotmail.com
342 E Jackson Blvd #A
Erwin, NC 28339

A H J

TOWN OF ERWIN

(910) 897-5140
P.O. BOX 459
ERWIN, NC 28339

UTILITY

DUKE ENERGY

(844) 388-7425

REVISIONS

04/22/21 PLAN SET JPM

BUILD SUMMARY

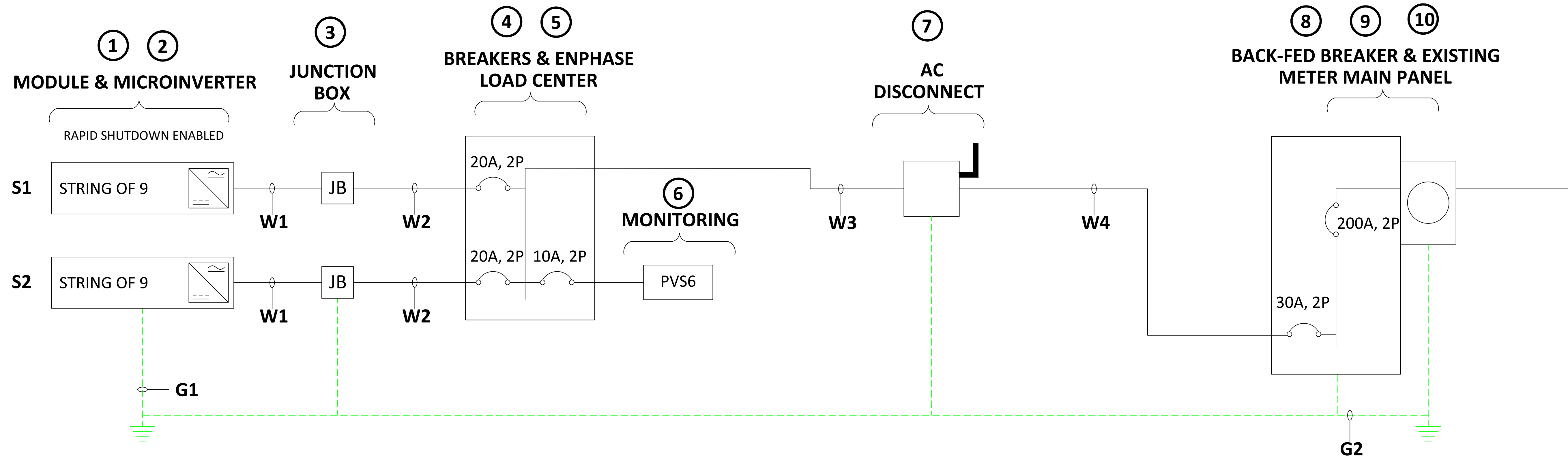

1 ONE-LINE ELECTRICAL DIAGRAM - 7.38 KW (DC)

03 NO SCALE

EQUIPMENT SCHEDULE						
TAG	ITEM	MAKE	MODEL	VOLTAGE	QTY	LOCATION
1	MODULE	SUNPOWER	SPR-A410	DC	18	ROOF TOP
2	MICROINVERTER	ENPHASE	IQ7X-96-2-US 315W (AC)	120/240V, 1Φ	18	ROOF TOP
3	JUNCTION BOX	VYNCKIER	RJ1	120/240V, 1Φ	2	ROOF TOP
4	BREAKERS	EATON	20A, 2-POLE BR220	120/240V, 1Φ	2	LOAD CENTER
5	LOAD CENTER	EATON	125A ENCLOSURE BR816L125RP	120/240V, 1Φ	1	BLD EXTERIOR
6	MONITORING	SUNPOWER	PVS6 SUPERVISOR	120/240V, 1Φ	1	BLD EXTERIOR
7	DISCONNECT	EATON	30A NON FUSED DG221URB, DG100NB	120/240V, 1Φ	1	BLD EXTERIOR
8	BACK-FED BREAKER	GE	30A, 2-POLE	120/240V, 1Φ	1	MAIN PANEL
9	MAIN PANEL	GE	200A ENCLOSURE 200A MAIN	120/240V, 1Φ	1	BLD INTERIOR
10	UTILITY METER	ITRON	CL200	120/240V, 1Φ	1	BLD EXTERIOR

WIRE SCHEDULE					
TAG	RUN	CONDUCTOR TYPE	GAUGE	CONDUIT	RUN LENGTH
W1	PV HOMERUNS	Q-CABLE Q-12-10-240-PORT	#12	-	60 FT
W2	JUNCTION BOX TO LOAD CENTER	THWN-2, Cu	#10	3/4"	30 FT
W3	LOAD CENTER TO DISCONNECT	THWN-2, Cu	#8	1"	5 FT
W4	DISCONNECT TO BACK-FED	THWN-2, Cu	#8	1"	5 FT
G1	GROUND ELECTRODE	BARE, Cu	#6	-	-
G2	EQUIPMENT GROUND (as per NEC 250.122)	THWN-2, Cu	#10 - #6	-	100 FT

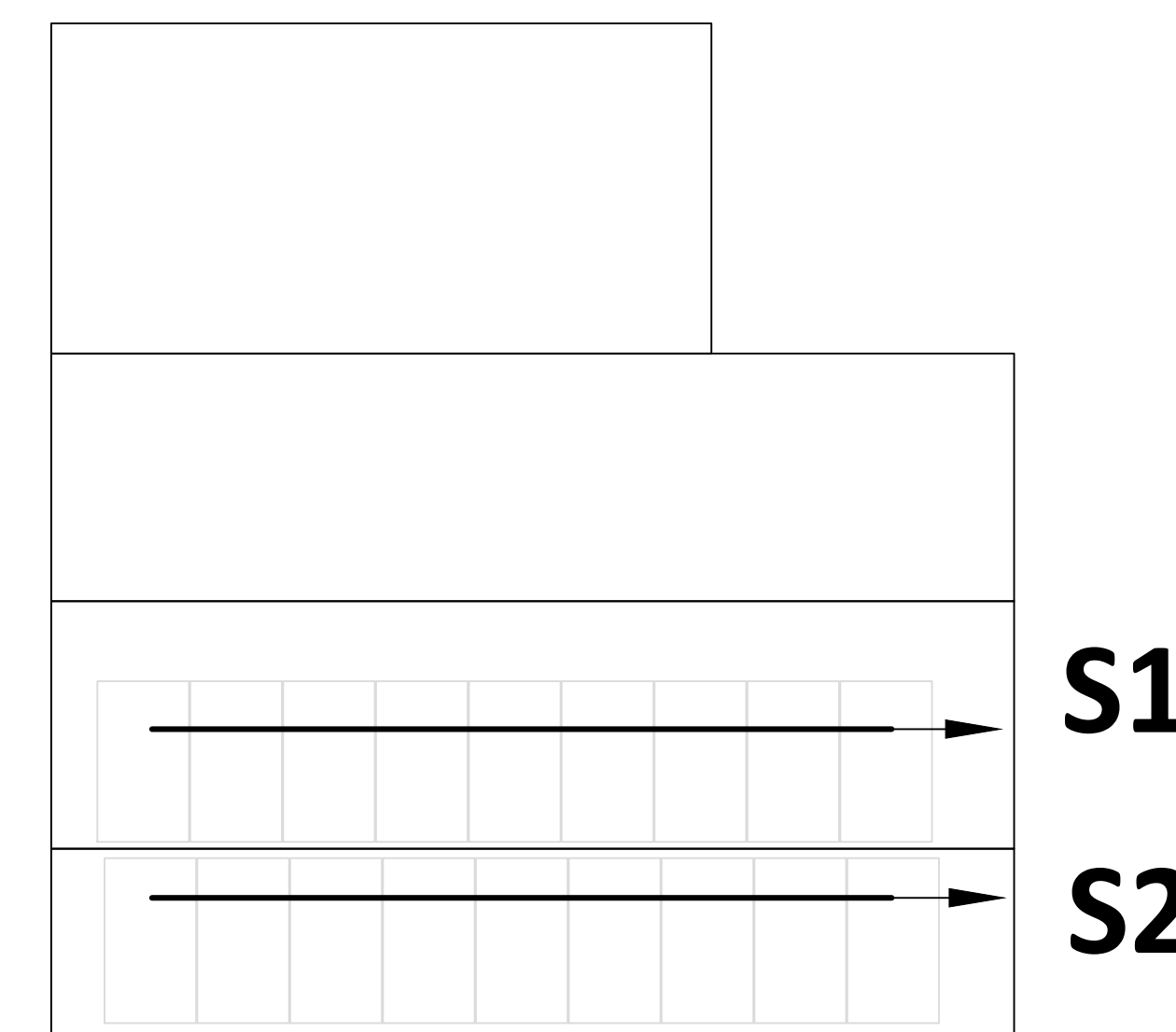

CONTRACTOR

MOXIE SOLAR

(855) 669-4387
 INFO@MOXIESOLAR.COM
 323 W CHERRY ST
 NORTH LIBERTY, IA 52317

OWNER

DAVID STRICKLAND

(910) 591-7149
 strickd@hotmail.com
 342 E Jackson Blvd #A
 Erwin, NC 28339

A H J

TOWN OF ERWIN

(910) 897-5140
 P.O. BOX 459
 ERWIN, NC 28339

UTILITY

DUKE ENERGY

(844) 388-7425

REVISIONS

04/22/21 PLAN SET JPM

ELECTRICAL

03

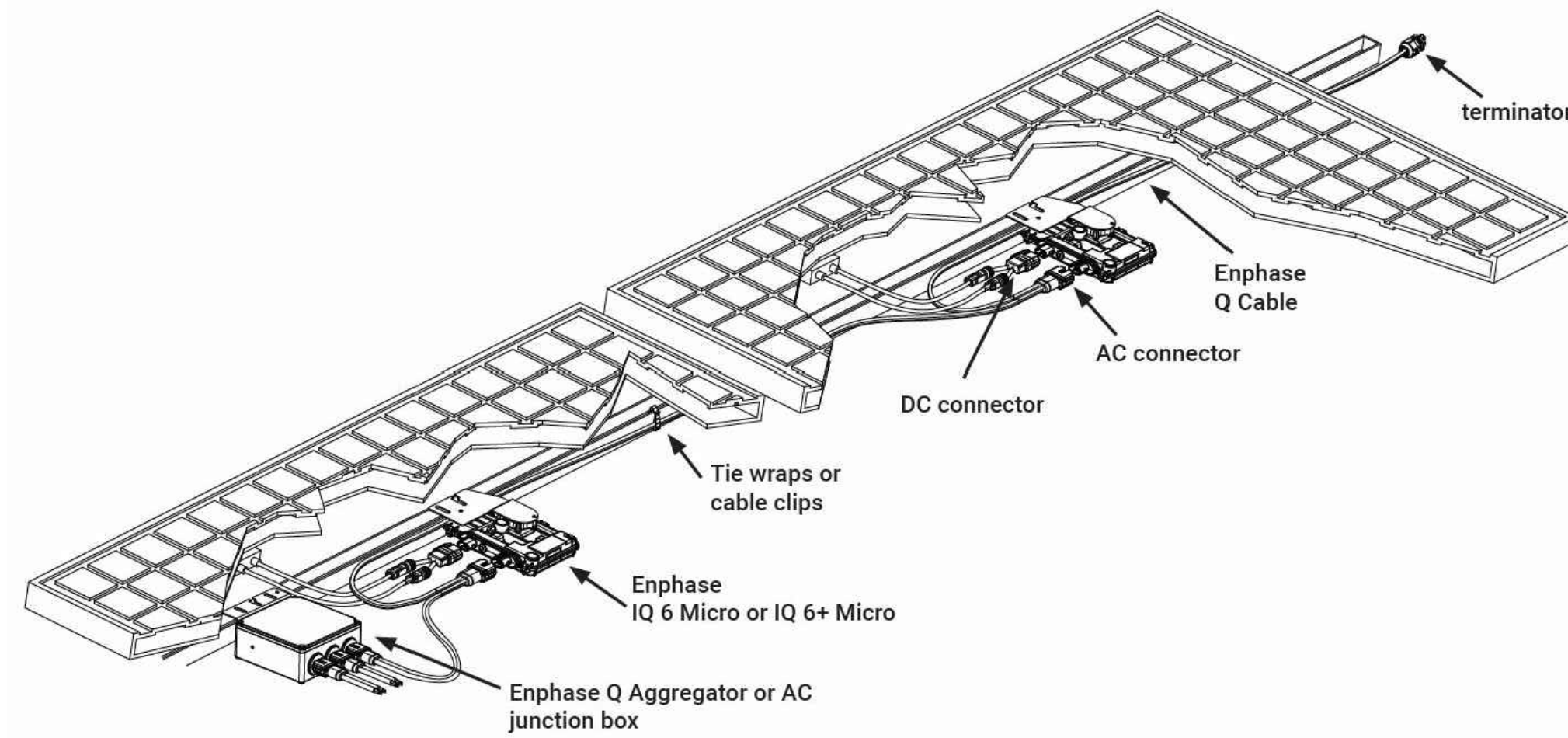

1
04 MODULE AND MICROINVERTER CONNECTION DETAIL
NO SCALE



2
04 S-5! SOLARFOOT DETAIL
NO SCALE

SYSTEM AC DISCONNECT AT SERVICE

PHOTOVOLTAIC SYSTEM AC DISCONNECT
 MAXIMUM OPERATING AC CURRENT: 23.58 AMPS
 NOMINAL OPERATING AC VOLTAGE: 120/240 VAC

3
04 PHOTOVOLTAIC MARKING AND LABELING
NO SCALE

CODE REVIEW & CALCULATIONS

SOLAR PHOTOVOLTAIC (PV) SYSTEM WITH ENPHASE

Inverter Type: Enphase IQ7X MicroInverter
 Minimum String Length: N/A
 Maximum String Length: 12
 Nominal String AC Voltage: 240V (AC)
 Nominal Output Current (Per MicroInverter): 1.31A

Sunpower SPR-A410

NEC 690.7 MAXIMUM VOLTAGE

690.7(A): Maximum Photovoltaic System Voltage
 SPR-A410 Module $V_{oc} = 48.20V$
 Module $V_{max} = ((-40^{\circ}C) - 25^{\circ}C)(-0.0029/^{\circ}C)(48.20V) + (48.20V) = 57.29V$ (DC)
 Module V_{max} Output = 57.29V (DC) < IQ7A MAX Input = 59V (DC)

NEC 690.8 CIRCUIT SIZING AND CURRENT

690.8(A)(1): Photovoltaic Source Circuit Currents
 Module to MicroInverter $I_{max} = 1.31A \times 18 \times 125\% = 29.48A$

690.8(A)(3): Inverter Output Circuit Current.
 MicroInverter Rated Continuous Output Power = 315W
 MicroInverter rated Continuous Output Current = 1.31A
 System $I_{max} = 29.48A$

NEC 690.9 OVERCURRENT PROTECTION

690.9(B): Overcurrent Device Ratings
 Disconnect Fuse: $1.31A \times 18 \times 125\% = 29.48A \rightarrow 30A$ OCPD

NEC 690.12 RAPID SHUTDOWN OF PV SYSTEMS ON BUILDINGS

PLAN: Rapid Shutdown enabled disconnect shall be located next to the service and be labeled in accordance with 690.56(B) and (C).



CONTRACTOR

MOXIE SOLAR

(855) 669-4387
 INFO@MOXIESOLAR.COM

323 W CHERRY ST
 NORTH LIBERTY, IA 52317

OWNER

DAVID STRICKLAND

(910) 591-7149
 strickd@hotmail.com

342 E Jackson Blvd #A
 Erwin, NC 28339

A H J

TOWN OF ERWIN

(910) 897-5140

P.O. BOX 459
 ERWIN, NC 28339

UTILITY

DUKE ENERGY

(844) 388-7425

REVISIONS

04/22/21 PLAN SET JPM

DETAILS & CALCULATIONS



VSE Project Number: U3340.0777.211

May 17, 2021

Moxie Solar
230 Sugar Creek Lane
North Liberty, IA 52317

REFERENCE: Strickland, David Residence: 342 East Jackson Boulevard, Erwin, NC 28339
Moxie Solar Project: NC-3662-1
Solar Array Installation

To Whom It May Concern:

Per your request, Elonzo Stroud, a representative of Vector Structural Engineering, LLC performed a site visit at the address above on May 10, 2021. The purpose of the visit was to observe the existing framing and determine the adequacy of the existing structure to support the proposed installation of solar panels on the roof.

Based upon our review, we conclude that the existing structure is adequate to support the proposed solar panel installation.

Design Parameters

Code: North Carolina Building Code, 2018 Edition (2015 IBC)

Risk Category: II

Design wind speed: 119 mph (3-sec gust) per ASCE 7-10

Wind exposure category: C

Ground snow load, Pg: 10 psf

Existing Roof Structure

Roof structure: 2x4 rafters @ 16" o.c.

Roofing material: metal corrugated

Roof 1: roof slope of 5°

Roof 2: roof slope of 14°

Connection to Roof

Mounting connection: (1) S-5! SolarFoot to 15/32" OSB w/ (4) 1/4"-14 x 1-1/2" wood screws

Maximum mounting spacing along rails:

Zone 1 (Beyond 4' from roof edge or ridge): 32" o.c.

Zone 2 (Within 4' of roof edge parallel or perpendicular to slope): 16" o.c.

Zone 3 (Within 4' of roof eave-eave corner or eave-ridge corner): 16" o.c.

(2) rails per row of panels, evenly spaced; panel length perpendicular to the rails not to exceed 67 in. Rail cantilever shall not exceed 50% of connection spacing.



Conclusions

Based upon our review, we conclude that the existing structure is adequate to support the proposed solar panel installation. In the area of the solar array, other live loads will not be present or will be greatly reduced (2018 NCBC, Section 1607.12.5). The gravity loads, and thus the stresses of the structural elements, in the area of the solar array are either decreased or increased by no more than 5%. Therefore, the requirements of Section 807.4 of the 2018 NCEBC (2015 IEBC) are met and the structure is permitted to remain unaltered.

The solar array will be flush-mounted (no more than 10" above the roof surface) and parallel to the roof surface. Thus, we conclude that any additional wind loading on the structure related to the addition of the proposed solar array is negligible. The attached calculations verify the capacity of the connections of the solar array to the existing roof against wind (uplift), the governing load case. Because the increase in lateral forces is less than 10%, this addition meets the requirements of the exception in Section 807.5 of the 2018 NCEBC (2015 IEBC). Thus the existing lateral force resisting system is permitted to remain unaltered.

Limitations

Installation of the solar panels must be performed in accordance with manufacturer recommendations. All work performed must be in accordance with accepted industry-wide methods and applicable safety standards. The contractor must notify Vector Structural Engineering, LLC should any damage, deterioration or discrepancies between the as-built condition of the structure and the condition described in this letter be found. Connections to existing roof framing must be staggered, except at array ends, so as not to overload any existing structural member. The use of solar panel support span tables provided by others is allowed only where the building type, site conditions, site-specific design parameters, and solar panel configuration match the description of the span tables. The design of the solar panel racking (mounts, rails, etc.) and electrical engineering is the responsibility of others. Waterproofing around the roof penetrations is the responsibility of others. Vector Structural Engineering assumes no responsibility for improper installation of the solar array.

VECTOR STRUCTURAL ENGINEERING, LLC

NC Firm License: COA #P-0742



05/17/2021

Jacob Proctor, P.E.

NC License: 049893 - Expires: 12/31/2021

Project Engineer

Enclosures

JSP/jeb



JOB NO.: U3340.0777.211
SUBJECT: WIND PRESSURE

PROJECT: Strickland, David Residence

Components and Cladding Wind Calculations

Label: Solar Panel Array

Note: Calculations per ASCE 7-10

SITE-SPECIFIC WIND PARAMETERS:

Basic Wind Speed [mph]: 119
 Exposure Category: C
 Risk Category: II

Notes:

ADDITIONAL INPUT & CALCULATIONS:

Height of Roof, h [ft]: 15 (Approximate)
 Comp/Cladding Location: Gable Roofs $\theta \leq 7^\circ$
 Enclosure Classification: Enclosed Buildings
 Zone 1 GC_p : 1.0 Figure 30.4-2A (enter negative pressure coefficients)
 Zone 2 GC_p : 1.8
 Zone 3 GC_p : 2.8
 α : 9.5 Table 26.9-1
 z_g [ft]: 900 Table 26.9-1
 K_h : 0.85 Table 30.3-1
 K_{zt} : 1 Equation 26.8-1
 K_d : 0.85 Table 26.6-1
 Velocity Pressure, q_h [psf]: 26.2 Equation 30.3-1
 GC_{pi} : 0 Table 26.11-1

PRESSURES: $p = q_h [(GC_p) - (GC_{pi})]$ Equation 30.9-1

Zone 1, p [psf]: 26.2 psf (1.0 W, Interior Zones, beyond 'a' from roof edge)
 Zone 2, p [psf]: 47.1 psf (1.0 W, End Zones, within 'a' from roof edge)
 Zone 3, p [psf]: 73.2 psf (1.0 W, Corner Zones, within 'a' from roof corner)
 (a= 3 ft)



JOB NO.: U3340.0777.211
SUBJECT: CONNECTION

PROJECT: Strickland, David Residence

Calculate Uplift Forces on Connection

	Pressure (0.6 Dead -0.6 Wind) (psf)	Max Trib. Width ¹ (ft)	Max Trib. Area ² (ft ²)	Max Uplift Force (lbs)
Zone 1	13.9	2.7	7.4	103
Zone 2	26.5	1.3	3.6	96
Zone 3	42.1	1.3	3.6	153

Calculate Connection Capacity

Roof Connector:	S-5! SolarFoot	
Additional Connection Info:	to 15/32" OSB w/ (4) 1/4"-14 x 1-1/2" wood screws	
Ultimate Capacity ³ [lbs/in]:	535	
Factor of Safety:	3	
Qty. of Connectors:	1	
Prying Coefficient:	1	
Total Capacity [lbs]:	178	

Determine Result

Maximum Demand:	153
Connection Capacity:	178

Result: **Capacity > Demand, Connection is adequate.**

Notes

1. 'Max Trib. Width' is the width along the rails tributary to the connection.
2. 'Max Trib Area' is the product of the 'Max. Trib Width' and 1/2 the panel width/height perpendicular to the rails. (2) rails per row of panels. Length of panels perpendicular to the rails shall not exceed 67".
3. Ultimate capacity values are from manufacturer testing.
4. Install metal roof connector per manufacturer's written instructions with recommended fasteners when indicated.



JOB NO.: U3340.0777.211
SUBJECT: GRAVITY LOADS

PROJECT: Strickland, David Residence

GRAVITY LOADS

Roof Pitch: :12

ROOF DEAD LOAD (D)	Design material weight [psf]	Increase due to pitch	Material weight [psf]
Metal Corrugated	3.0	1.00	3.0
1/2" Plywood	1.0	1.00	1.0
Framing	3.0		3.0
Insulation	0.0		0.0
1/2" Gypsum Clg.	0.0	1.00	0.0
M, E & Misc	0.0		0.0
Total Existing Roof DL	7.0		
PV Array DL	3.0	1.00	3

ROOF LIVE LOAD (Lr)

Existing Design Roof Live Load [psf]	<input type="text" value="20"/>	ASCE 7-10 Table 4-1
Roof Live Load With PV Array [psf]	<input type="text" value="0"/>	2018 NCBC, Section 1607.12.5

SNOW LOAD (S):

Existing w/ Solar Array

Roof Slope [x:12]:	<input type="text" value="1.0"/>	<input type="text" value="1.0"/>	
Roof Slope [°]:	<input type="text" value="5"/>	<input type="text" value="5"/>	
Ground Snow Load, p_g [psf]:	<input type="text" value="10"/>	<input type="text" value="10"/>	ASCE 7-10, Section 7.2
Terrain Category:	<input type="text" value="C"/>	<input type="text" value="C"/>	ASCE 7-10, Table 7-2
Exposure of Roof:	<input type="text" value="Fully Exposed"/>	<input type="text" value="Fully Exposed"/>	ASCE 7-10, Table 7-2
Exposure Factor, C_e :	<input type="text" value="0.9"/>	<input type="text" value="0.9"/>	ASCE 7-10, Table 7-2
Thermal Factor, C_t :	<input type="text" value="1.1"/>	<input type="text" value="1.1"/>	ASCE 7-10, Table 7-3
Risk Category:	<input type="text" value="II"/>	<input type="text" value="II"/>	ASCE 7-10, Table 1.5-1
Importance Factor, I_s :	<input type="text" value="1.0"/>	<input type="text" value="1.0"/>	ASCE 7-10, Table 1.5-2
Flat Roof Snow Load, p_f [psf]:	<input type="text" value="7"/>	<input type="text" value="7"/>	ASCE 7-10, Equation 7.3-1
Minimum Roof Snow Load, p_m [psf]:	<input type="text" value="10"/>	<input type="text" value="10"/>	ASCE 7-10, Section 7.3.4
Unobstructed Slippery Surface?	<input type="text" value="Yes"/>	<input type="text" value="Yes"/>	ASCE 7-10, Section 7.4
Slope Factor Figure:	<input type="text" value="Figure 7-2b"/>	<input type="text" value="Figure 7-2b"/>	ASCE 7-10, Section 7.4
Roof Slope Factor, C_s :	<input type="text" value="1.00"/>	<input type="text" value="1.00"/>	ASCE 7-10, Figure 7-2
Sloped Roof Snow Load, p_s [psf]:	<input type="text" value="7"/>	<input type="text" value="7"/>	ASCE 7-10, Equation 7.4-1
Design Snow Load, S [psf]:	<input type="text" value="10"/>	<input type="text" value="10"/>	



JOB NO.: U3340.0777.211
SUBJECT: LOAD COMPARISON

PROJECT: Strickland, David Residence

Summary of Loads

	Existing	With PV Array
D [psf]	7	10
Lr [psf]	20	0
S [psf]	10	10

Maximum Gravity Loads:

	Existing	With PV Array	
(D + Lr) / Cd [psf]	22	11	ASCE 7-10, Section 2.4.1
(D + S) / Cd [psf]	15	17	ASCE 7-10, Section 2.4.1

(Cd = Load Duration Factor = 0.9 for D, 1.15 for S, and 1.25 for Lr)

Maximum Gravity Load [psf]:	22	17
-----------------------------	----	----

Ratio Proposed Loading to Current Loading:

81%

OK

The gravity loads, and thus the stresses of the structural elements, in the area of the solar array are either decreased or increased by no more than 5%. Therefore, the requirements of Section 807.4 of the 2018 NCEBC (2015 IEBC) are met and the structure is permitted to remain unaltered.



420-390 W Residential AC Module

SunPower® Maxeon® Technology

Built specifically for use with the SunPower Equinox™ system, the only fully integrated solution designed, engineered, and warranted by one manufacturer.

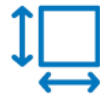

Highest Power Density Available.

SunPower's new Maxeon® Gen 5 cell is 65% larger than prior generations, delivering the most powerful cell and highest-efficiency module in residential solar. The result is more power per square meter than any commercially available solar.

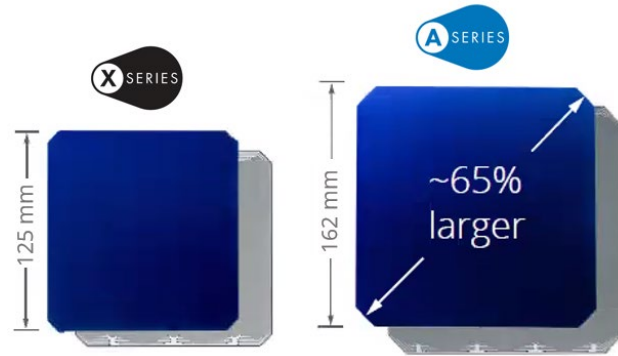

Fundamentally Different. And Better.

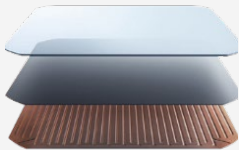

SunPower® Maxeon® Technology

- Most powerful cell in home solar ²
- Delivers unmatched reliability ³
- Patented solid metal foundation prevents breakage and corrosion



Factory-integrated Microinverter (MI)

- Highest-power integrated AC module in solar
- 60% lighter than prior SunPower MIs
- Engineered and calibrated by SunPower for SunPower AC modules



Highest Lifetime Energy and Savings.

Designed to deliver 60% more energy over 25 years in real-world conditions like partial shade and high temperatures.¹

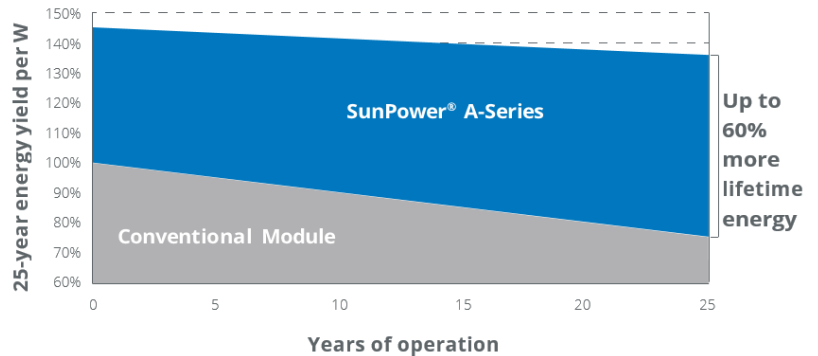

Best Reliability. Best Warranty.

With more than 25 million modules deployed around the world, SunPower technology is proven to last. That's why we stand behind our module and microinverter with the industry's best 25-year Combined Power and Product Warranty, including the highest Power Warranty in solar.



AC Electrical Data	
Inverter Model: Type G / SPWR-A4 (IQ 7AS)	@240 VAC
Peak Output Power	366 VA
Max. Continuous Output Power	349 VA
Nom. (L-L) Voltage/Range ² (V)	240 / 211–264
Max. Continuous Output Current (A)	1.45
Max. Units per 20 A (L-L) Branch Circuit ³	11
CEC Weighted Efficiency	97.0%
Nom. Frequency	60 Hz
Extended Frequency Range	47–68 Hz
AC Short Circuit Fault Current Over 3 Cycles	5.8 A rms
Overvoltage Class AC Port	III
AC Port Backfeed Current	18 mA
Power Factor Setting	1.0
Power Factor (adjustable)	0.7 lead. / 0.7 lag.

DC Power Data					
	A420-G-AC	A415-G-AC	A410-G-AC	A400-G-AC	A390-G-AC
Nom. Power ⁵ (Pnom) W	420	415	410	400	390
Power Tol.	+5/-0%				
Module Efficiency	22.5	22.3	22.0	21.5	20.9
Temp. Coef. (Power)	-0.29%/°C				
Shade Tol.	Integrated module-level max. power point tracking				

Tested Operating Conditions	
Operating Temp.	-40°F to +185°F (-40°C to +85°C)
Max. Ambient Temp.	122°F (50°C)
Max. Test Load ⁷	Wind: 125 psf, 6000 Pa, 611 kg/m ² back Snow: 187 psf, 9000 Pa, 917 kg/m ² front
Design Load	Wind: 75 psf, 3600 Pa, 367 kg/m ² back Snow: 125 psf, 6000 Pa, 611 kg/m ² front
Impact Resistance	1 inch (25 mm) diameter hail at 52 mph (23 m/s)

Mechanical Data	
Solar Cells	66 Monocrystalline Maxeon Gen 5
Front Glass	High-transmission tempered glass with anti-reflective coating
Environmental Rating	Outdoor rated
Frame	Class 1 black anodized (highest AAMA rating)
Weight	46.5 lbs (21.1 kg)
Recommended Max. Module Spacing	1.3 in. (33 mm)

1 SunPower 415 W, 22.3% efficient, compared to a Conventional Panel on same-sized arrays (260 W, 16% efficient, approx. 1.6 m²), 7.9% more energy per watt (based on PVSyst pan files for avg. US climate), 0.5%/yr slower degradation rate (Jordan, et. al. "Robust PV Degradation Methodology and Application." PVSC 2018).
 2 Based on search of datasheet values from websites of top 10 manufacturers per IHS, as of January 2019.
 3 #1 rank in "Fraunhofer PV Durability Initiative for Solar Modules: Part 3." PV Tech Power Magazine, 2015. Campeau, Z. et al. "SunPower Module Degradation Rate," SunPower white paper, 2013.
 4 Factory set to 1547a-2014 default settings. CA Rule 21 default settings profile set during commissioning.
 5 Standard Test Conditions (1000 W/m² irradiance, AM 1.5, 25°C). NREL calibration standard: SOMS current, LACCS FF and voltage. All DC voltage is fully contained within the module.
 6 This product is UL Listed as PVRSE and conforms with NEC 2014 and NEC 2017 690.12; and C22.1-2015 Rule 64-218 Rapid Shutdown of PV Systems, for AC and DC conductors; when installed according to manufacturer's instructions.
 7 Please read the safety and installation instructions for more information regarding load ratings and mounting configurations.

See www.sunpower.com/facts for more reference information.
 For more details, see extended datasheet www.sunpower.com/datasheets Specifications included in this datasheet are subject to change without notice.
 ©2020 SunPower Corporation. All Rights Reserved. SUNPOWER, the SUNPOWER logo, Equinox, and MAXEON are registered trademarks of SunPower Corporation in the U.S. and other countries as well. 1-800-SUNPOWER.

Warranties, Certifications, and Compliance	
Warranties	<ul style="list-style-type: none"> • 25-year limited power warranty • 25-year limited product warranty
Certifications and Compliance	<ul style="list-style-type: none"> • UL 1703 • UL 1741 / IEEE-1547 • UL 1741 AC Module (Type 2 fire rated) • UL 62109-1 / IEC 62109-2 • FCC Part 15 Class B • ICES-0003 Class B • CAN/CSA-C22.2 NO. 107.1-01 • CA Rule 21 (UL 1741 SA)⁴ (includes Volt/Var and Reactive Power Priority) • UL Listed PV Rapid Shutdown Equipment⁶ <p>Enables installation in accordance with:</p> <ul style="list-style-type: none"> • NEC 690.6 (AC module) • NEC 690.12 Rapid Shutdown (inside and outside the array) • NEC 690.15 AC Connectors, 690.33(A)-(E)(1) <p>When used with InvisiMount racking and InvisiMount accessories (UL 2703):</p> <ul style="list-style-type: none"> • Module grounding and bonding through InvisiMount • Class A fire rated <p>When used with AC module Q Cables and accessories (UL 6703 and UL 2238)⁶:</p> <ul style="list-style-type: none"> • Rated for load break disconnect
PID Test	Potential-induced degradation free

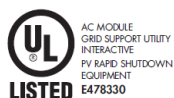
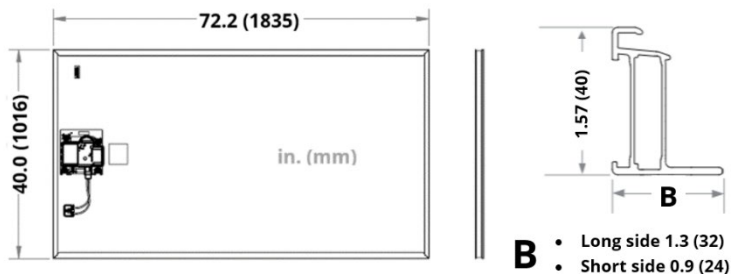

Module Fire Performance: Type 2
 Please read the Safety and Installation Instructions 532628 for additional details.

SUNPOWER®

Enphase IQ 7X Microinverter

The high-powered smart grid-ready **Enphase IQ 7X Micro™** dramatically simplifies the installation process while achieving the highest system efficiency for systems with 96-cell modules.

Part of the Enphase IQ System, the IQ 7X Micro integrates with the Enphase IQ Envoy™, Enphase IQ Battery™, and the Enphase Enlighten™ monitoring and analysis software.

The IQ Series Microinverters extend the reliability standards set forth by previous generations and undergo over a million hours of power-on testing, enabling Enphase to provide an industry-leading warranty of up to 25 years.



Easy to Install

- Lightweight and simple
- Faster installation with improved, lighter two-wire cabling
- Built-in rapid shutdown compliant (NEC 2014 & 2017)

Efficient and Reliable

- Optimized for high powered 96-cell* modules
- Highest CEC efficiency of 97.5%
- More than a million hours of testing
- Class II double-insulated enclosure
- UL listed

Smart Grid Ready

- Complies with advanced grid support, voltage and frequency ride-through requirements
- Remotely updates to respond to changing grid requirements
- Configurable for varying grid profiles
- Meets CA Rule 21 (UL 1741-SA)

* The IQ 7X is required to support 96-cell modules.



Enphase IQ 7X Microinverter

INPUT DATA (DC)		IQ7X-96-2-US	
Commonly used module pairings ¹	320 W - 460 W +		
Module compatibility	96-cell PV modules		
Maximum input DC voltage	79.5 V		
Peak power tracking voltage	53 V - 64 V		
Operating range	25 V - 79.5 V		
Min/Max start voltage	33 V / 79.5 V		
Max DC short circuit current (module I _{sc})	10 A		
Overvoltage class DC port	II		
DC port backfeed current	0 A		
PV array configuration	1 x 1 ungrounded array; No additional DC side protection required; AC side protection requires max 20A per branch circuit		
OUTPUT DATA (AC)		@ 240 VAC	@ 208 VAC
Peak output power	320 VA		
Maximum continuous output power	315 VA		
Nominal (L-L) voltage/range ²	240 V / 211-264 V	208 V / 183-229 V	
Maximum continuous output current	1.31 A (240 VAC)	1.51 A (208 VAC)	
Nominal frequency	60 Hz		
Extended frequency range	47 - 68 Hz		
AC short circuit fault current over 3 cycles	5.8 Arms		
Maximum units per 20 A (L-L) branch circuit ³	12 (240 VAC)	10 (208 VAC)	
Overvoltage class AC port	III		
AC port backfeed current	18 mA		
Power factor setting	1.0		
Power factor (adjustable)	0.85 leading ... 0.85 lagging		
EFFICIENCY		@240 VAC	@208 VAC
CEC weighted efficiency	97.5 %	97.0 %	
MECHANICAL DATA			
Ambient temperature range	-40°C to +60°C		
Relative humidity range	4% to 100% (condensing)		
Connector type (IQ7X-96-2-US)	MC4 (or Amphenol H4 UTX with optional Q-DCC-5 adapter)		
Dimensions (WxHxD)	212 mm x 175 mm x 30.2 mm (without bracket)		
Weight	1.08 kg (2.38 lbs)		
Cooling	Natural convection - No fans		
Approved for wet locations	Yes		
Pollution degree	PD3		
Enclosure	Class II double-insulated, corrosion resistant polymeric enclosure		
Environmental category / UV exposure rating	NEMA Type 6 / outdoor		
FEATURES			
Communication	Power Line Communication (PLC)		
Monitoring	Enlighten Manager and MyEnlighten monitoring options Compatible with Enphase IQ Envoy		
Disconnecting means	The AC and DC connectors have been evaluated and approved by UL for use as the load-break disconnect required by NEC 690.		
Compliance	CA Rule 21 (UL 1741-SA) UL 62109-1, UL1741/IEEE1547, FCC Part 15 Class B, ICES-0003 Class B, CAN/CSA-C22.2 NO. 107.1-01 This product is UL Listed as PV Rapid Shut Down Equipment and conforms with NEC-2014 and NEC-2017 section 690.12 and C22.1-2015 Rule 64-218 Rapid Shutdown of PV Systems, for AC and DC conductors, when installed according manufacturer's instructions.		

1. No enforced DC/AC ratio. See the compatibility calculator at <https://enphase.com/en-us/support/module-compatibility>.

2. Nominal voltage range can be extended beyond nominal if required by the utility.

3. Limits may vary. Refer to local requirements to define the number of microinverters per branch in your area.

To learn more about Enphase offerings, visit enphase.com



SunPower® InvisiMount™ | Residential Mounting System

Simple and Fast Installation

- Integrated module-to-rail grounding
- Pre-assembled mid and end clamps
- Levitating mid clamp for easy placement
- Mid clamp width facilitates even module spacing
- Simple, pre-drilled rail splice
- UL 2703 Listed integrated grounding

Flexible Design

- Addresses nearly all sloped residential roofs
- Design in landscape and portrait
- Rails enable easy obstacle management

Customer-Preferred Aesthetics

- #1 module and #1 mounting aesthetics
- Best-in-class system aesthetics
- Premium, low-profile design
- Black anodized components
- Hidden mid clamps and end clamps hardware, and capped, flush rails

Part of Superior System

- Built for use with SunPower DC and AC modules
- Best-in-class system reliability and aesthetics
- Combine with SunPower modules and monitoring app



Elegant Simplicity

SunPower® InvisiMount™ is a SunPower-designed rail-based mounting system. The InvisiMount system addresses residential sloped roofs and combines faster installation time, design flexibility, and superior aesthetics. The InvisiMount product was specifically envisioned and engineered to pair with SunPower modules. The resulting system-level approach will amplify the aesthetic and installation benefits for both homeowners and installers.

sunpower.com



SUNPOWER®



SunPower® InvisiMount™ | Residential Mounting System

InvisiMount Component Images

Module* / Mid Clamp and Rail

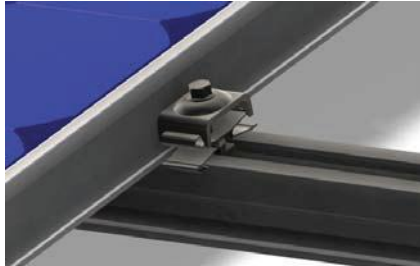

Module* / End Clamp and Rail

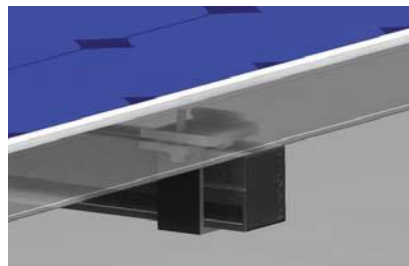

Mid Clamp



End Clamp



Rail & Rail Splice



Ground Lug Assembly



End Cap



InvisiMount Component Details		
Component	Material	Weight
Mid Clamp	Black oxide stainless steel AISI 304	63 g (2.2 oz)
End Clamp	Black anodized aluminum alloy 6063-T6	110 g (3.88 oz)
Rail	Black anodized aluminum alloy 6005-T6	830 g/m (9 oz/ft)
Rail Splice	Aluminum alloy 6005-T5	830 g/m (9 oz/ft)
Ground Lug Assembly	304 stainless (A2-70 bolt; tin-plated copper lug)	106.5 g/m (3.75 oz)
End Cap	Black acetal (POM) copolymer	10.4 g (0.37 oz)

InvisiMount Operating Conditions	
Temperature	-40° C to 90° C (-40° F to 194° F)
Max. Load	2400 Pa uplift 5400 Pa downforce

InvisiMount Warranties And Certifications	
Warranties	25-year product warranty 5-year finish warranty
Certifications	UL 2703 Listed Class A fire rating when distance between roof surface and bottom of SunPower module frame is ≤ 3.5"

Roof Attachment Hardware Supported by InvisiMount System Design Tool	
Application	<ul style="list-style-type: none"> • Composition Shingle Rafter Attachment • Composition Shingle Roof Decking Attachment • Curved and Flat Tile Roof Attachment • Universal Interface for Other Roof Attachments

Roof Attachment Hardware Warranties	
Refer to roof attachment hardware manufacturer's documentation	

*Module frame that is compatible with the InvisiMount system required for hardware interoperability.

© 2015 SunPower Corporation. All Rights Reserved. SUNPOWER, the SUNPOWER logo, and INVISIMOUNT are trademarks or registered trademarks of SunPower Corporation. All other trademarks are the property of their respective owners. Specifications included in this datasheet are subject to change without notice.