



# CERTIFICATE OF LIABILITY INSURANCE

DATE (MM/DD/YYYY)

10/01/2020

THIS CERTIFICATE IS ISSUED AS A MATTER OF INFORMATION ONLY AND CONFERS NO RIGHTS UPON THE CERTIFICATE HOLDER. THIS CERTIFICATE DOES NOT AFFIRMATIVELY OR NEGATIVELY AMEND, EXTEND OR ALTER THE COVERAGE AFFORDED BY THE POLICIES BELOW. THIS CERTIFICATE OF INSURANCE DOES NOT CONSTITUTE A CONTRACT BETWEEN THE ISSUING INSURER(S), AUTHORIZED REPRESENTATIVE OR PRODUCER, AND THE CERTIFICATE HOLDER.

**IMPORTANT:** If the certificate holder is an ADDITIONAL INSURED, the policy(ies) must have ADDITIONAL INSURED provisions or be endorsed. If SUBROGATION IS WAIVED, subject to the terms and conditions of the policy, certain policies may require an endorsement. A statement on this certificate does not confer rights to the certificate holder in lieu of such endorsement(s).

<b>PRODUCER</b> WOOMER Insurance 106 N Salem St.  Apex NC 27502		<b>CONTACT NAME:</b> Commercial Cert <b>PHONE (A/C, No. Ext):</b> (919)290-6000 <b>E-MAIL ADDRESS:</b> Biz@woomerinsurance.com <b>FAX (A/C, No):</b> (919)362-5661	
<b>INSURED</b> NC Solar Now Inc. 2517 Atlantic Avenue  Raleigh NC 27604		<b>INSURER(S) AFFORDING COVERAGE</b>	
		<b>INSURER A:</b> Builders Mutual Insurance Co	<b>NAIC #</b> 000000
		<b>INSURER B:</b> ERIE INS EXCH	<b>NAIC #</b> 26271
		<b>INSURER C:</b> Builders Mutual Insurance Co	<b>NAIC #</b> 000000
		<b>INSURER D:</b> Builders Mutual Insurance Co	<b>NAIC #</b> 000000
		<b>INSURER E:</b> Builders Mutual Insurance Co	<b>NAIC #</b> 000000
		<b>INSURER F:</b>	

**COVERAGES****CERTIFICATE NUMBER:****REVISION NUMBER:**

THIS IS TO CERTIFY THAT THE POLICIES OF INSURANCE LISTED BELOW HAVE BEEN ISSUED TO THE INSURED NAMED ABOVE FOR THE POLICY PERIOD INDICATED. NOTWITHSTANDING ANY REQUIREMENT, TERM OR CONDITION OF ANY CONTRACT OR OTHER DOCUMENT WITH RESPECT TO WHICH THIS CERTIFICATE MAY BE ISSUED OR MAY PERTAIN, THE INSURANCE AFFORDED BY THE POLICIES DESCRIBED HEREIN IS SUBJECT TO ALL THE TERMS, EXCLUSIONS AND CONDITIONS OF SUCH POLICIES. LIMITS SHOWN MAY HAVE BEEN REDUCED BY PAID CLAIMS.

INSR LTR	TYPE OF INSURANCE	ADDL INSD	SUBR WVD	POLICY NUMBER	POLICY EFF (MM/DD/YYYY)	POLICY EXP (MM/DD/YYYY)	LIMITS
A	<input checked="" type="checkbox"/> <b>COMMERCIAL GENERAL LIABILITY</b> <input type="checkbox"/> CLAIMS-MADE <input checked="" type="checkbox"/> OCCUR  GEN'L AGGREGATE LIMIT APPLIES PER: <input checked="" type="checkbox"/> POLICY <input type="checkbox"/> PRO-JECT <input type="checkbox"/> LOC OTHER:	N	N	CPP0067951-06	10/10/2020	10/10/2021	EACH OCCURRENCE \$ 1000000 DAMAGE TO RENTED PREMISES (Ea occurrence) \$ 100000 MED EXP (Any one person) \$ 5000 PERSONAL & ADV INJURY \$ 1000000 GENERAL AGGREGATE \$ 2000000 PRODUCTS - COMP/OP AGG \$ 2000000 \$
B	<b>AUTOMOBILE LIABILITY</b> <input checked="" type="checkbox"/> ANY AUTO <input checked="" type="checkbox"/> OWNED AUTOS ONLY <input type="checkbox"/> SCHEDULED AUTOS <input checked="" type="checkbox"/> HIRED AUTOS ONLY <input checked="" type="checkbox"/> NON-OWNED AUTOS ONLY	N	N	Q11-1930595	11/19/2019	11/19/2020	COMBINED SINGLE LIMIT (Ea accident) \$ 1000000 BODILY INJURY (Per person) \$ BODILY INJURY (Per accident) \$ PROPERTY DAMAGE (Per accident) \$ \$
C	<input checked="" type="checkbox"/> <b>UMBRELLA LIAB</b> <input checked="" type="checkbox"/> OCCUR <input type="checkbox"/> EXCESS LIAB <input type="checkbox"/> CLAIMS-MADE DED RETENTION \$	N	N	MUB0004920-04	10/10/2020	10/10/2021	EACH OCCURRENCE \$ 5000000 AGGREGATE \$ 5000000 \$
D	<b>WORKERS COMPENSATION AND EMPLOYERS' LIABILITY</b> ANY PROPRIETOR/PARTNER/EXECUTIVE OFFICER/MEMBER EXCLUDED? (Mandatory in NH) If yes, describe under DESCRIPTION OF OPERATIONS below	Y/N	N/A	WCP1041654-06	10/10/2020	10/10/2021	<input checked="" type="checkbox"/> PER STATUTE <input type="checkbox"/> OTH-ER E.L. EACH ACCIDENT \$ 1000000 E.L. DISEASE - EA EMPLOYEE \$ 1000000 E.L. DISEASE - POLICY LIMIT \$ 1000000
E	Business Property	N	N	CPP0067951-06	10/10/2020	10/10/2021	\$150,000 w/\$1000 deductible

DESCRIPTION OF OPERATIONS / LOCATIONS / VEHICLES (ACORD 101, Additional Remarks Schedule, may be attached if more space is required)

For Information Purposes Only

**CERTIFICATE HOLDER****CANCELLATION**

For Information Purposes Only

SHOULD ANY OF THE ABOVE DESCRIBED POLICIES BE CANCELLED BEFORE THE EXPIRATION DATE THEREOF, NOTICE WILL BE DELIVERED IN ACCORDANCE WITH THE POLICY PROVISIONS.

AUTHORIZED REPRESENTATIVE

Fax:

Email:

© 1988-2015 ACORD CORPORATION. All rights reserved.

ACORD 25 (2016/03)

The ACORD name and logo are registered marks of ACORD

**DO NOT REMOVE!**

**Details: Appointment of Lien Agent**

Entry #: 1400784

Filed on: 02/11/2021

Initially filed by: ncsolarnow

**Designated Lien Agent**

Chicago Title Company, LLC

**Online:** [www.liensnc.com](http://www.liensnc.com) (<http://www.liensnc.com>)

**Address:** 223 S. West Street, Suite 900 /  
Raleigh, NC 27603

**Phone:** 888-690-7384

**Fax:** 913-489-5231

**Email:** [support@liensnc.com](mailto:support@liensnc.com) (<mailto:support@liensnc.com>)

**Project Property**

70 Character Court  
Bunnlevel, NC 28323  
Harnett County

**Property Type**

1-2 Family Dwelling

**Print & Post**



**Contractors:**

Please post this notice on the Job Site.

**Suppliers and Subcontractors:**

Scan this image with your smart phone to view this filing. You can then file a Notice to Lien Agent for this project.

**Owner Information**

Frank Tucker  
70 Character Court  
Bunnlevel, NC 28323  
United States  
Email: [hndac143@gmail.com](mailto:hndac143@gmail.com)  
Phone: 910-574-4044

**Date of First Furnishing**

02/01/2021

View Comments (0)

**Technical Support Hotline:** (888) 690-7384

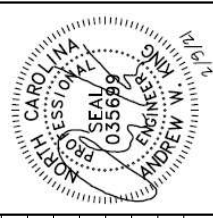

**CLIENT INFO**  
 FRANK W. TUCKER II  
 70 CHARACTER COURT  
 RAINLEVEL, NC 28323

**PROJECT INFO**  
 DC INPUT: 10.88kW  
 AC EXPORT: 10.00kW  
 DOWNSPT. METHOD: OPTION 2

**CODE REFERENCES**  
 NATIONAL ELECTRICAL CODE v. 2017  
 NC FIRE PROTECTION CODE v. 2016  
 NC BUILDING CODE v. 2018  
 NC RESIDENTIAL CODE v. 2018  
 ASCE v. 40

**SITE CONDITIONS**  
 WIND SPEED: 118 MPH  
 RISK CATEGORY: II  
 EXPOSURE: B  
 SNOW: 10 PSF

**SHEET INDEX**  
 PV-1: COVER SHEET  
 PV-2: PV STRUCTURAL  
 PV-3: PV ELECTRICAL  
 PV-4: PV EQUIPMENT LABELS  
 PV-5: PV INSTALL GUIDE

**DESIGNER INFO**  
 CRM  
 DESIGNER: ANDREW M. HESS  
 ENGINEER: ANDREW M. HESS  
 DATE: 2/5/2021  
 VERSION: P1

PV SYSTEM COVER  
 PAGE

PV-1.1

**PV MATERIAL SUMMARY: DISTRIBUTOR**

Q: PEAK DUO BLK-C6+340	32
P: 340	32
SE10000H-US0008NU4	1
SE4-ELL-8-R05-US-S-52	16
XR-10-168B	2
XR-10-204B	8
XR10-BOSS-01-M1	78
UFO-CL-01-B1	28
UFO-STP-32MM-B1	8
XR-LUG-01-A1	122
NANO DECK MOUNT	7
CC66803 Cececel Sealant	2
SOLADECK 0799-53	

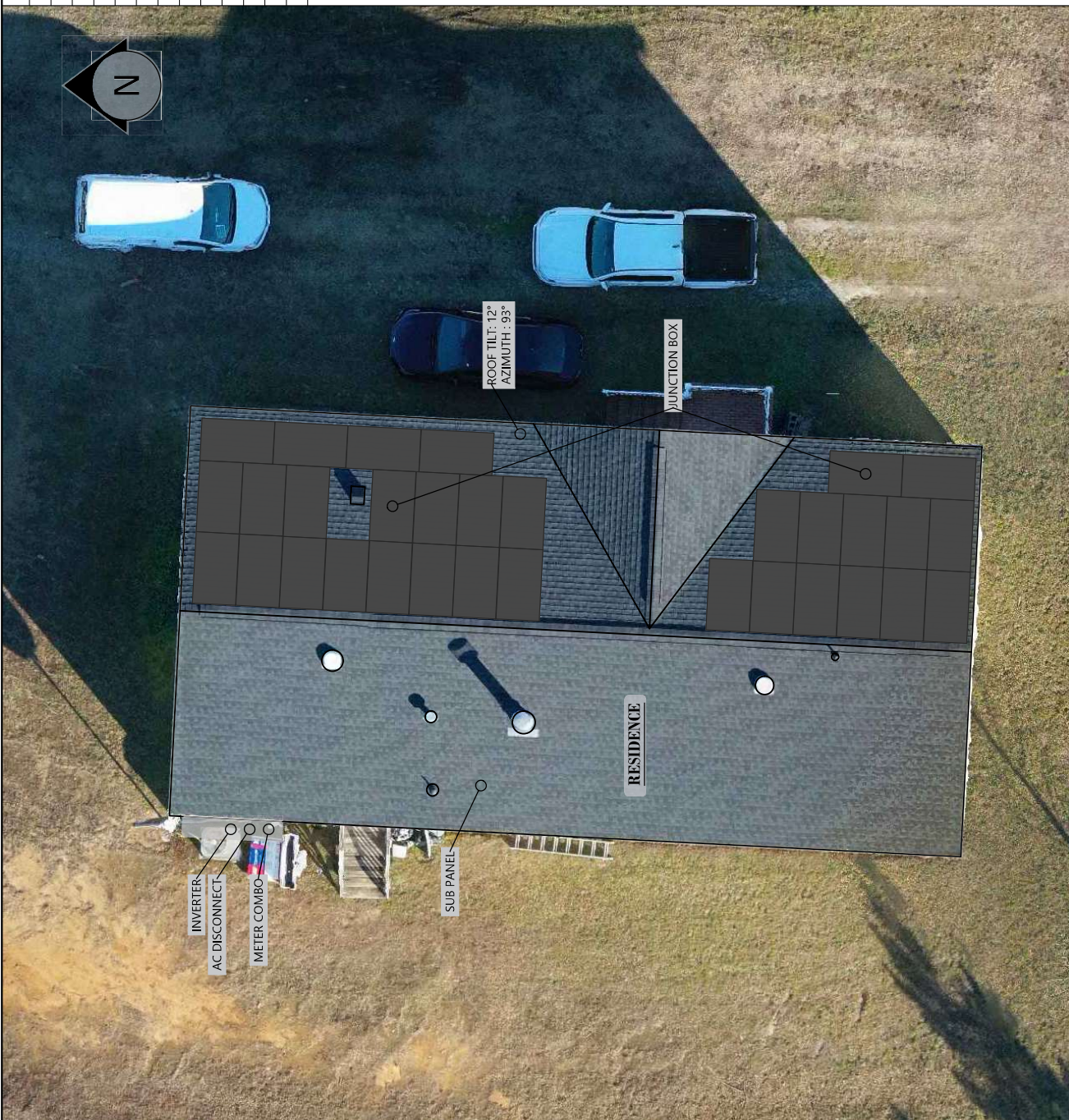

**STATEMENT OF STRUCTURAL COMPLIANCE**

THE EXISTING ROOF STRUCTURE HAS BEEN DESIGNED TO SUPPORT THE ADDITIONAL LOADS OF THE PROPOSED PV SYSTEM. IN ADDITION, THE RACKING AND FASTENING SYSTEM SHALL BE CAPABLE OF SECURING THE SYSTEM TO THE STRUCTURE UNDER DESIGN CONDITIONS WHEN INSTALLED PROPERLY AND IN ACCORDANCE WITH THE RACKING AND FASTENING ARRANGEMENT DETAILED WITHIN THESE DRAWINGS.

NAME: ANDREW W. KING, PE  
 SIGNED: 

**PV MODULES**

MAKE	HANWHA
MODEL	Q.PAK DUO BK-G66-340
WIDTH	40.60 IN
LENGTH	68.50 IN
THICKNESS	32 MM
WEIGHT	43.90 LBS
ARRAY AREA	618 SQ.FT.
ARRAY WEIGHT	1545 LBS

**ROOF SUMMARY**

STRUCTURE:	
TYPE	TRUSSES
MATERIAL	SOUTHERN PINE #2
SIZE	2 X 6
SPACING	24" O.C.
ALLOWABLE SPAN	88 FT
PITCH	0/12
DENSITY	30 LBS./CU.FT.
DICING:	
TYPE	OSB
MATERIAL	COMPOSITE
THICKNESS	7/16 IN
WEIGHT	1.60 LBS./SQ.FT.
ROOFING:	
TYPE	ASPHALT SHINGLE
MATERIAL	ASPHALT
WEIGHT	2.10 LBS./SQ.FT.

**ROOF MOUNT SUMMARY**

MAXIMUM (MIN) ANCHOR SPACING	RAIL OVERHANG
WIND ZONE 1	PORT 43 LAND 72
WIND ZONE 2	PORT 10 LAND 18
WIND ZONE 3	PORT 26 LAND 44
PORT 10 LAND 18	
PORT 17 LAND 20	PORT 7 LAND 12

**ROOF LOADING**

GROUND SNOW LOAD:	15 LBS./SQ.FT.
LIVE LOAD:	20 LBS./SQ.FT.
DEAD LOAD:	
ROOFING:	3.9 LBS./SQ.FT.
PV ARRAY:	2.5 LBS./SQ.FT.
TOTAL:	6.4 LBS./SQ.FT.
WIND LOAD:	
UPHIFT ZONE 1	-23.0 LBS./SQ.FT.
UPHIFT ZONE 2	-80.0 LBS./SQ.FT.
UPHIFT ZONE 3	-97.1 LBS./SQ.FT.
DOWNGRADE FASTENING:	13.6 LBS./SQ.FT.
UPHIFT ZONE 1	-23.1 LBS.
UPHIFT ZONE 2	-79.1 LBS.
UPHIFT ZONE 3	-97.9 LBS.
DOWNGRADE:	13.7 LBS.

**ROOF MOUNT & FASTENER**

ROOF MOUNT:	
MAKE	SUNMODO
MODEL	NANO DECK MOUNT
MATERIAL	ALUMINUM / SILICONE
FASTENER:	
MAKE	SUNMODO
MODEL	B1007-HR1
MATERIAL	STAINLESS STEEL
SIZE	1/4" X 3"
GENERAL:	
WEIGHT	4
FASTENERS PER MOUNT	4
MAX. PULL-OUT FORCE	4700 LBS.
SAFETY FACTOR	2
DESIGN PULL-OUT FORCE	2350 LBS.

**MOUNTING RAILS**

MAKE	IRONRIDGE
MODEL	XRD
MATERIAL	ALUMINUM
WEIGHT	0.425 LBS/LIN
SPACING	34 IN

**STATEMENT OF STRUCTURAL COMPLIANCE**

THE EXISTING ROOF STRUCTURE HAS BEEN DESIGNED TO SUPPORT THE ADDITIONAL LOADS OF THE PROPOSED PV SYSTEM. IN ADDITION, THE RACKING AND FASTENING SYSTEM SHALL BE CAPABLE OF SECURING THE SYSTEM TO THE STRUCTURE UNDER DESIGN CONDITIONS WHEN INSTALLED PROPERLY AND IN ACCORDANCE WITH THE RACKING AND FASTENING ARRANGEMENT DETAILED WITHIN THESE DRAWINGS.

NAME: ANDREW W. KING, PE  
 SIGNED: 

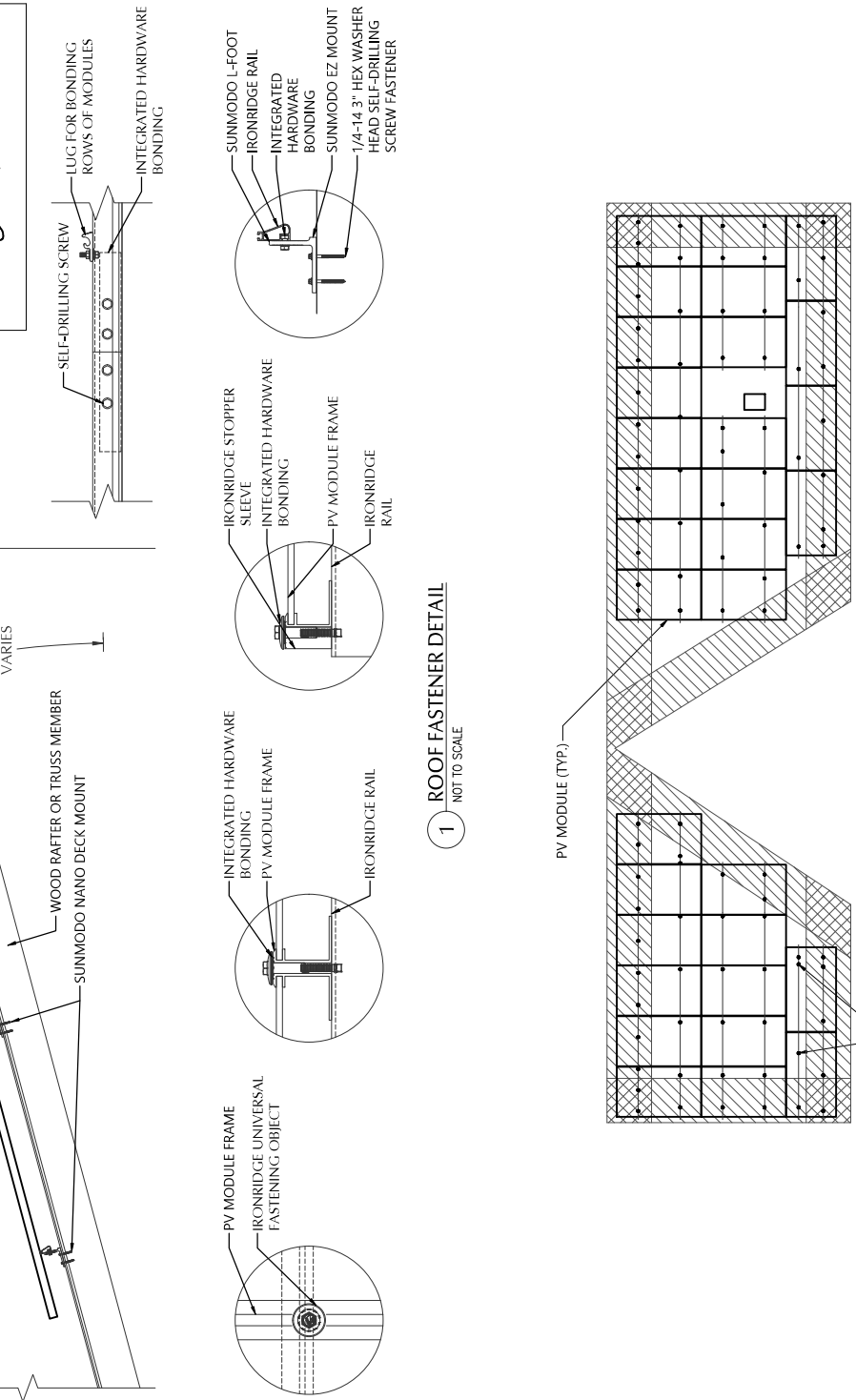

**CLIENT INFO**

FRANK W. TUCKER II  
 70 CHARACTER COURT  
 RAINLEVEL, NC 28323

**PROJECT INFO**

DC INPUT: 10.88 KW  
 AC INPUT: 10.00 KW  
 DC INSP. METHOD: OPTION 2

**CODE REFERENCES**

NATIONAL ELECTRICAL CODE v. 2017  
 NC FIRE PROTECTION CODE v. 2016  
 NC BUILDING CODE v. 2018  
 NC RESIDENTIAL CODE v. 2018  
 ASCE v. 7-10

**SITE CONDITIONS**

WIND SPEED: 118 MPH  
 RISK CATEGORY: II  
 EXPOSURE: B  
 SNOW: 10 PSF

**SHEET INDEX**

PC-1: COVER SHEET  
 PC-2: PV STRUCTURAL  
 PC-3: PV ELECTRICAL  
 PC-4: PV EQUIPMENT LABELS  
 PC-5: PV INSTALL GUIDE

**DESIGNER INFO**

CRM  
 ENGINEER: AWK  
 DATE: 2/5/2021  
 VERSION: P1

**PV SYSTEM STRUCTURAL**

**PV-2.1**



**DC / AC INVERTER**

MAKE	SOLAEDGE
MODEL	SE1000H4-5000WRL4
DC INPUT:	
NOM. POWER	15500 WATTS
VOLT. RANGE	400-480
NOM. VOLT.	400 VOLTS
MAX. CURRENT	27 AMPS
STRING INPUTS	3 STRINGS
AC OUTPUT:	
NOM. POWER	10000 WATTS
NOM. VOLT.	240 VOLTS
NOM. VOLT.	211-240-264
MAX. CURR.	42.00 AMPS
MAX. CURR.	YES
RATED TO DISCONNECT	YES
PHOTO VOLTAGE (V/N)	YES
UL LIST (V/N)	UL LIST: V/N
CONSUMPTION MONITOR	YES

**AC DISCONNECT**

MAKE	GENERIC
MODEL	NA
ENCL. RATING	NEMA 3R
VOLT. RATING	240 VOLTS
AMP. RATING	60 AMPS
UL LIST (V/N)	YES
FUSED (V/N)	YES
FUSE RATING	60 AMPS

**MODULE OPTIMIZER**

MAKE	SOLAEDGE
MODEL	P-140
DC INPUT:	
NOM. POWER (PNOM)	340 WATTS
NOM. VOLT. (VNMPP)	33.9 VOLTS
VOLT. RANGE	8 to 48
G.C. VOLT. (VOC)	40.7 VOLTS
MAX. SYS. VOLT.	11.0 AMPS
NOM. CURR. (INMPP)	10.0 AMPS
S.C. CURR. (ISC)	10.5 AMPS
TEMP. COEFF. (PPMPP)	-41.96 %/C
TEMP. COEFF. (VOC)	-41.27 %/C
MAX. SERIES FUSE	20 AMPS
UL LIST (V/N)	YES

**JUNCTION BOX**

MAKE	SOLAEDGE
MODEL	NEMA TYPE 3R
PROJECT RATING	YES
UL LIST (V/N)	YES

**MD PANEL (EXISTING)**

MAKE	GE
MODEL	NEMA 3R
ENCL. RATING	NEMA 3R
VOLT. RATING	240
BUS RATING	200 AMPS
UL LIST (V/N)	YES
MAIN BREAKER (V/N)	YES
MAIN BREAKER RATING	200 AMPS

**PV MODULE**

MAKE	HANWHA
MODEL	Q-PEAK DUO DIBK-G6+340
NOM. POWER (PNOM)	340 WATTS
NOM. VOLT. (VNMPP)	33.9 VOLTS
G.C. VOLT. (VOC)	40.7 VOLTS
MAX. SYS. VOLT.	11.0 AMPS
NOM. CURR. (INMPP)	10.0 AMPS
S.C. CURR. (ISC)	10.5 AMPS
TEMP. COEFF. (PPMPP)	-41.96 %/C
TEMP. COEFF. (VOC)	-41.27 %/C
MAX. SERIES FUSE	20 AMPS
UL LIST (V/N)	YES

**SUB PANEL (EXISTING)**

MAKE	CUTLER-HAMMER
MODEL	BR240B200CK
ENCL. RATING	NEMA 1
VOLT. RATING	240 VOLTS
BUS RATING	200 AMPS
UL LIST (V/N)	YES
MAIN BREAKER (V/N)	YES
MAIN BREAKER RATING	200 AMPS

**CONDUCTOR SCHEDULE**

TAG	CURRENT CARRYING CONDUCTORS		GROUNDING CONDUCTORS		CONDUIT/TRACEWAY		NOTES
	QTY.	SIZE	INSULATION	QTY.	SIZE	LOCATION	
C1	4	10 AWG	PV WIRE	1	6 AWG	BARE	FREE AIR
C2	4	10 AWG	THWN	1	3/4"	EXT/INT	2,4
C3	3	10 AWG	THWN	1	3/4"	EXTERIOR	2,4
C4	3	6 AWG	THWN	1	3/4"	EXTERIOR	2,4
NC	.	.	.	.	.	.	3

- NOTES:**
- MANUFACTURER PROVIDED, UL LISTED WIRING HARNESS FOR USE ON EXPOSED ROOFS
  - CONDUIT SIZE SHOWN IS CODE MINIMUM. LARGER SIZES ARE ALLOWED.
  - EXISTING CONDUCTORS, FIELD VERIFY
  - EQUIPMENT TERMINAL RATING SHALL BE A MINIMUM OF 75°C AT BOTH END OF CONDUCTOR

- LOAD-BREAK RATED
- VERIFY OPEN POSITION
- INSTALL ADJACENT TO METER
- DISCONNECT TO BE READILY ACCESSIBLE
- TO UTILITY COMPANY PERSONNEL AT ALL TIMES

- BACK-FEED SOLAR OUTPUT VIA LOAD SIDE
- TAP IN BETWEEN OUTDOOR MAIN BREAKER AND MAIN BREAKER IN SUB PANEL
- MAIN BREAKER SERVES AS SERVICE DISCONNECT SWITCH
- INCLUDE WARNING STICKER FOR NEC SECTION 705

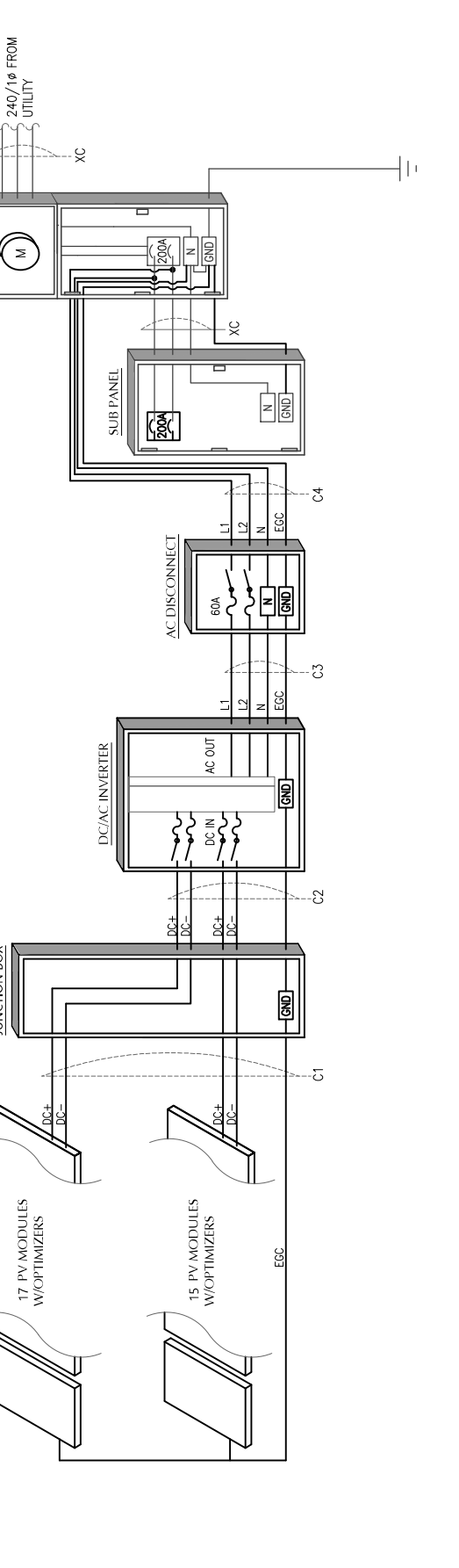

1 ELECTRICAL SCHEMATIC  
NTS

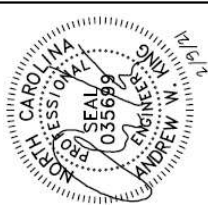

**CLIENT INFO**  
FRANK W. TUCKER II  
70 CHARACTER COURT  
RINNELEVE, NC 28223

**PROJECT INFO**  
DC INPUT: 10.88kW  
AC EXPORT: 10.00kW  
DC/INSP. METHOD: OPTION 2

**CODE REFERENCES**  
NATIONAL ELECTRICAL CODE V. 2017  
NC FIRE PROTECTION CODE V. 2008  
NC BUILDING CODE V. 2018  
NC RESIDENTIAL CODE V. 2018  
AGE: V. 740

**SITE CONDITIONS**  
WIND SPEED: 118 MPH  
RISK CATEGORY: II  
EXPOSURE: B  
SNOW: 10 PSF

**SHEET INDEX**  
P1-1: COVER SHEET  
P1-2: PV STRUCTURAL  
P1-3: PV ELECTRICAL  
P1-4: PV EQUIPMENT LABELS  
P1-5: PV INSTALL GUIDE

**DESIGNER INFO**  
CRM  
DESIGNER: ANW  
ENGINEER: 25/2021  
DATE: P1  
VERSION: P1

**PV SYSTEM EQUIPMENT LABELS**

**PV-4.1**

**CONSTRUCTION NOTES**

- ALL WORK IS TO BE PERFORMED IN ACCORDANCE WITH THE NEC, STATE, AND LOCAL APPLICABLE CODES.
- FOLLOW MANUFACTURER'S INSTALLATION INSTRUCTIONS, BEST PRACTICES, AND SPECIFICATIONS.
- ENSURE REQUIRED MAINTENANCE ACCESS AND CLEARANCES ARE MAINTAINED.
- WIRES SHALL BE RATED AND LABELED "SUNLIGHT RESISTANT" WHERE EXPOSED TO AMBIENT CONDITIONS.
- FUSES 0 - 600 AMPS SHALL BE UL CLASS "RK-1" LOW PEAK DUAL ELEMENT TIME DELAY WITH 200000 AMPERE INTERRUPTING RATING AS MANUFACTURED BY BUSSMANN, UNLESS NOTED OTHERWISE.
- ALL TERMINALS/PLUGS SHALL BE 75° RATED. ALL TERMINALS, SPlicing CONNECTORS, LUGS, ETC SHALL BE IDENTIFIED FOR USE WITH THE MATERIAL (CU/AL) OF THE CONDUCTOR AND SHALL BE PROPERLY INSTALLED.
- PROVIDE A PULLWIRE IN ALL EMPTY CONDUITS.
- ALL PENETRATIONS THROUGH EXTERIOR ROOFS SHALL BE FLASHED IN A WATERPROOF MANNER.
- ALL PENETRATIONS THROUGH ATTIC FIRE BARRIERS SHALL BE SEALED WITH FIRE-BARRIER SEALANT CAULK.
- SUPPORT ALL CONDUIT AND EQUIPMENT IN ACCORDANCE W/ NEC. ANY SUSPENDED MATERIALS SHALL BE DIRECTLY SUPPORTED BY THE BUILDING STRUCTURE.
- METAL CONDUIT COUPLINGS CAN BE COMPRESSION TYPE, THREADED, OR BE SET-SCREW TYPE. PLASTIC CONDUIT COUPLINGS TO BE SOCKET GLUED TYPE.
- A COMPLETE GROUNDING SYSTEM SHALL BE PRESENT OR PROVIDED AS SHOWN ON THE DRAWINGS.
- EACH ELECTRICAL APPLIANCE SHALL BE PROVIDED WITH A NAMEPLATE GIVING THE IDENTIFYING NAME AND THE RATING IN VOLTS AND AMPERES OR VOLTS AND WATTS. IF THE APPLIANCE IS TO BE USED ON A SPECIFIC FREQUENCY OR FREQUENCIES, IT SHALL BE SO MARKED.
- WHERE MOTOR OVERLOAD PROTECTION EXTERNAL TO THE APPLIANCE IS REQUIRED, THE APPLIANCE SHALL BE SO MARKED.
- WHERE APPLICABLE, GROUNDING ELECTRODE CONDUCTOR TO BE CONTINUOUS. GROUNDING CRIMPS TO BE IRREVERSIBLE.
- PHOTOVOLTAIC SYSTEMS SHALL BE PERMANENTLY MARKED AT VARIOUS EQUIPMENT LOCATIONS TO IDENTIFY THAT A PHOTOVOLTAIC SYSTEM IS INSTALLED AND THAT VARIOUS DANGERS ARE PRESENT.
- EACH PHOTOVOLTAIC SYSTEM DISCONNECTING MEANS SHALL BE PERMANENTLY MARKED TO IDENTIFY IT AS A PHOTOVOLTAIC SYSTEM DISCONNECT.
- WHERE ALL TERMINALS OF A DISCONNECTING MEANS MAY BE ENERGIZED IN THE OPEN POSITION, A WARNING SIGN SHALL BE MOUNTED ON OR ADJACENT TO THE DISCONNECT.
- A PERMANENT LABEL FOR THE DIRECT-CURRENT PHOTOVOLTAIC POWER SOURCE SHALL BE PROVIDED AT THE DC DISCONNECT MEANS.
- A PERMANENT PLAQUE OR DIRECTORY, DENOTING ALL ELECTRIC POWER SOURCES SERVING THE PREMISES, SHALL BE INSTALLED AT EACH SERVICE EQUIPMENT LOCATION AND AT LOCATIONS OF ALL POWER PRODUCTION SOURCES.
- ALL MODULE GROUND CONNECTIONS SHALL BE MADE IN ACCORDANCE WITH NEC SECTION 690.4(C).
- A NORTH CAROLINA REGISTERED DESIGN PROFESSIONAL WILL BE REQUIRED TO SEAL THE STRUCTURAL DESIGN AT THE TIME OF PERMIT APPLICATION IF ANY OF THE FOLLOWING EXIST AND ARE ATTESTED TO BY THE APPLICANT:
  - THE WEIGHT OF THE PV SYSTEM EXCEEDS THREE (3) POUNDS PER SQUARE FOOT (PSF).
  - THE ROOF POSSESSES MORE THAN ONE (1) LAYER OF ASPHALT SHINGLES.
  - THE ROOFING MATERIAL CONSISTS OF A TYPE OTHER THAN ASPHALT SHINGLES OR METAL.
  - THE ROOF IS LOCATED IN A 140 MPH OR GREATER WIND ZONE.

**LABEL NOTES**

- LABELS SHOWN ARE HALF THEIR ACTUAL REQUIRED SIZE.
- LABEL MATERIAL SHALL BE SUITABLE FOR THE EQUIPMENT ENVIRONMENT.
- DC CONDUIT SHALL BE MARKED WITH REQUIRED LABEL EVERY 10 FEET.
- LABELS WILL BE APPLIED IN ACCORDANCE WITH THE NEC. SOME LABELS MAY NOT BE NECESSARY.

**DC WIRING NOTES**

- CONDUCTORS SHALL BE COPPER, RATED AT NOT LESS THAN 600 VOLTS FOR RESIDENTIAL CONSTRUCTION AND NOT LESS THAN 1000 VOLTS FOR COMMERCIAL CONSTRUCTION.
- MINIMUM SIZE SHALL BE #10 AWG UNLESS OTHERWISE NOTED ON THE DRAWINGS.
- EXPOSED WIRING CONDUCTOR INSULATION SHALL BE TYPE PV WIRE, USE-2, OR RHW-2 WHERE THE OUTER LAYER OF THE INSULATION IS UV, SUNLIGHT, AND MOISTURE RESISTANT.
- EXTERIOR WIRING CONDUCTOR INSULATION SHALL BE TYPE THWN-2 AND INSTALLED IN ELECTRICAL METALLIC TUBING (EMT) OR RIGID POLYVINYL CHLORIDE CONDUIT (PVC), ALTERNATIVELY, METAL CLAD CABLE (MC), CAN BE USED AS WELL WHEN RATED FOR USE IN WET LOCATIONS.
- INTERIOR WIRING CONDUCTOR INSULATION SHALL BE TYPE THHN-2 AND INSTALLED IN ELECTRICAL METALLIC TUBING (EMT), FLEXIBLE METAL CONDUIT (FMC), OR METAL CLAD CABLE (MC).
- USE SCHEDULE 40 PVC OUTDOORS WHERE NOT SUBJECT TO PHYSICAL DAMAGE OR BELOW FLOOR SLAB. USE SCHEDULE 80 PVC OUTDOORS WHERE SUBJECT TO PHYSICAL DAMAGE.
- MINIMUM CONDUIT SIZE TO BE 1/2".
- WIRING METHODS TO CONFORM TO ARTICLES 330, 334, 348, 350, 352, 356, AND 358 OF THE 2017 NEC.

**AC WIRING NOTES**

- CONDUCTORS SHALL BE COPPER RATED AT NOT LESS THAN 600 VOLTS.
- MINIMUM SIZE SHALL BE #14 AWG UNLESS OTHERWISE NOTED ON THE DRAWINGS.
- EXTERIOR WIRING CONDUCTOR INSULATION SHALL BE TYPE THWN AND INSTALLED IN ELECTRICAL METALLIC TUBING (EMT), RIGID POLYVINYL CHLORIDE CONDUIT (PVC), LIQUID-TIGHT FLEXIBLE METAL CONDUIT (LFMC), OR LIQUID-TIGHT FLEXIBLE NON-METALLIC CONDUIT (LFNMC), ALTERNATIVELY, METAL CLAD CABLE (MC) CAN BE USED AS WELL WHEN RATED FOR USE IN WET LOCATIONS.
- INTERIOR WIRING CONDUCTOR INSULATION SHALL BE TYPE THHN AND INSTALLED IN ELECTRICAL METALLIC TUBING (EMT), FLEXIBLE METAL CONDUIT (FMC), METAL CLAD CABLE (MC), OR ROMEX.
- USE SCHEDULE 40 PVC OUTDOORS WHERE NOT SUBJECT TO PHYSICAL DAMAGE OR BELOW FLOOR SLAB. USE SCHEDULE 80 PVC OUTDOORS WHERE SUBJECT TO PHYSICAL DAMAGE.
- MINIMUM CONDUIT SIZE TO BE 1/2".
- WIRING METHODS TO CONFORM TO ARTICLES 330, 334, 348, 350, 352, 356, AND 358 OF THE 2017 NEC.

**WARNING**  
DUAL POWER SUPPLY  
SOURCES: UTILITY GRID AND PV SOLAR ELECTRIC SYSTEM

NEC 705.12(B)(4)  
PLACE ON ALL EQUIPMENT THAT IS SUPPLIED BY BOTH POWER SOURCES

**WARNING**  
POWER SOURCE OUTPUT CONNECTION DO NOT RELOCATE THIS OVERCURRENT DEVICE

NEC 705.12(B)(2)(b)(i)  
PLACE ADJACENT TO BACK-FED BREAKER

**WARNING**  
ELECTRIC SHOCK HAZARD TERMINALS ON THE LINE AND LOAD SIDES MAY BE ENERGIZED IN THE OPEN POSITION

NEC 690.13(B)  
PLACE ON PV SYSTEM DISCONNECTING MEANS

**SOLAR PV SYSTEM EQUIPPED WITH RAPID SHUTDOWN**

TURN RAPID SHUTDOWN SWITCH TO THE "OFF" POSITION TO AND REDUCE SHOCK HAZARD IN THE ARRAY

NEC 690.56(C)(4)(b)  
PLACE WITHIN 3 FT OF SERVICE DISCONNECTING MEANS TO WHICH THE PV SYSTEMS ARE CONNECTED AND SHALL INDICATE THE LOCATIONS OF RAPID SHUTDOWN SWITCHES

**WARNING: PHOTOVOLTAIC POWER SOURCE**

NEC 690.31(G)(3)(6)(4)  
PLACE ON ALL JUNCTION BOXES, EXPOSED RACEWAYS, AND OTHER WIRING ENCLOSURES, WALLS, PARTITIONS, CEILING, OR FLOORS

**RAPID SHUTDOWN SWITCH FOR SOLAR PV SYSTEM**

NEC 690.56(C)(4)  
PLACE ON RAPID SHUTDOWN SWITCH OR EQUIPMENT WITH INTEGRATED RAPID SHUTDOWN "REFLECTIVE"

**PHOTOVOLTAIC POWER SOURCE**  
OPERATING AC VOLTAGE 240 V  
MAXIMUM OPERATING AC OUTPUT CURRENT 42.0 A

NEC 690.54  
PLACE ON INTERCONNECTION DISCONNECTING MEANS

**PV SYSTEM DISCONNECT**

NEC 690.13(B)  
PLACE ON PV SYSTEM DISCONNECTING MEANS

**WARNING**  
TOTAL RATING OF ALL OVERCURRENT DEVICES EXCLUDING UTILITY OVERCURRENT DEVICE SHALL NOT EXCEED AMPACITY OF BUSBAR

NEC 705.12(B)(2)(3)(6)  
PLACE IN METER COMBO

**DIRECT CURRENT PHOTOVOLTAIC POWER SOURCE**  
MAXIMUM VOLTAGE 600 VDC  
MAX CIRCUIT CURRENT 30.0 AMPS

NEC 690.53  
PLACE ON ALL DC DISCONNECTING MEANS

**PV SYSTEM DISCONNECT**

NEC 690.13(B)  
PLACE ON PV SYSTEM DISCONNECTING MEANS

**WARNING**  
TOTAL RATING OF ALL OVERCURRENT DEVICES EXCLUDING UTILITY OVERCURRENT DEVICE SHALL NOT EXCEED AMPACITY OF BUSBAR

NEC 705.12(B)(2)(3)(6)  
PLACE IN METER COMBO



**CLIENT INFO**  
 FRANK W. TUCKER II  
 70 CHARACTER COURT  
 RAINLEVEL, NC 28323

**PROJECT INFO**  
 DC INPUT: 10.88kW  
 AC EXPORT: 10.00kW  
 DOWNSPT. METHOD: OPTION 2

**CODE REFERENCES**  
 NATIONAL ELECTRICAL CODE V. 2017  
 NC FIRE PROTECTION CODE V. 2016  
 NC BUILDING CODE V. 2018  
 NC RESIDENTIAL CODE V. 2018  
 ASCE V. 7-10

**SITE CONDITIONS**  
 WIND SPEED: 118 MPH  
 RISK CATEGORY: II  
 EXPOSURE: B  
 SNOW: 10 PSF

**SHEET INDEX**  
 PV-1: COVER SHEET  
 PV-2: PV STRUCTURAL  
 PV-3: PV ELECTRICAL  
 PV-4: PV EQUIPMENT LABELS  
 PV-5: PV INSTALL GUIDE

**DESIGNER INFO**  
 CRM  
 DESIGNER: AWK  
 ENGINEER: P1  
 DATE: 2/2/2021  
 VERSION: P1

**PV SYSTEM INSTALL GUIDE**

# PV-5.1

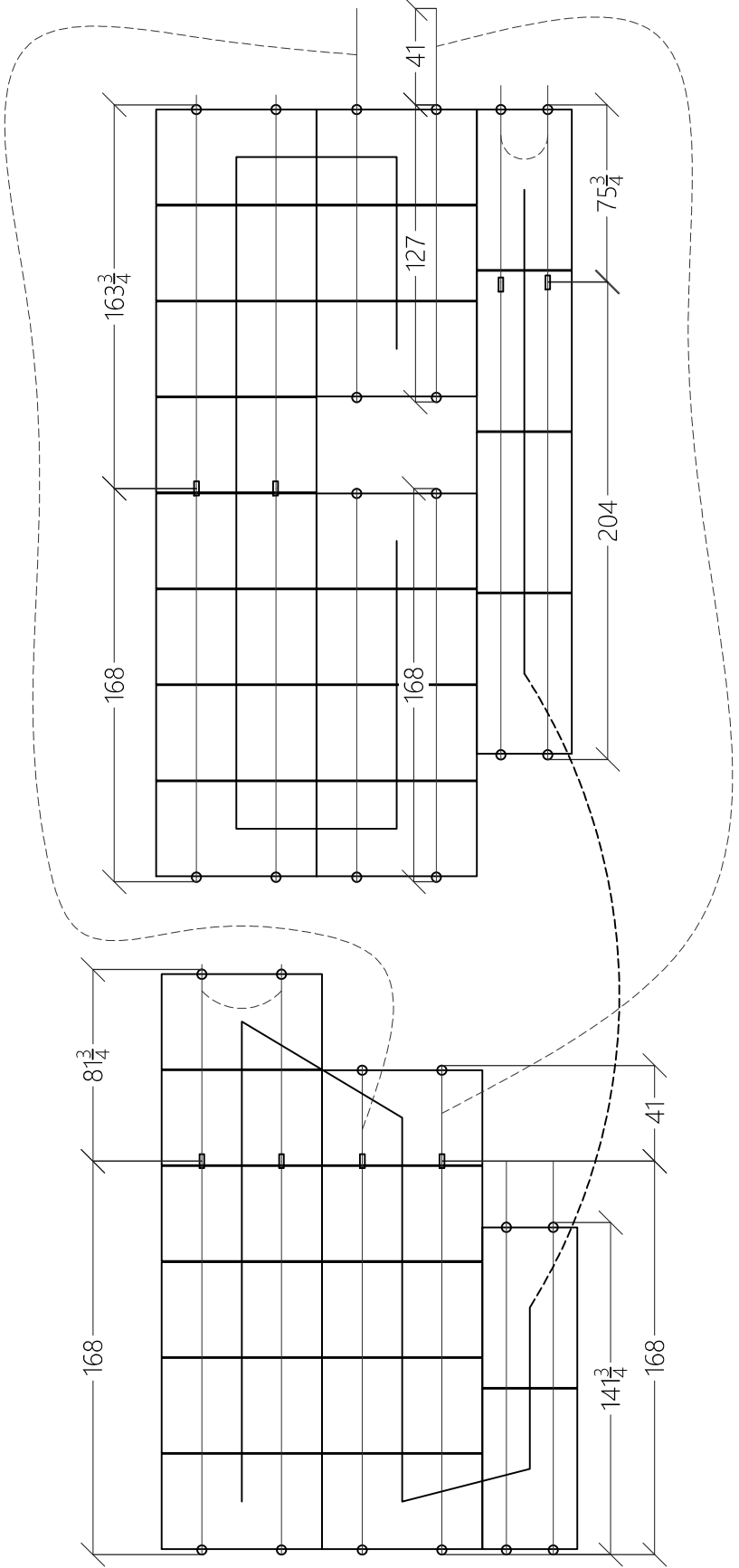

1 ARRAY LAYOUT DETAIL  
 NOT TO SCALE

NOTE: THERE MUST BE AT LEAST TWO ATTACHMENTS ON BOTH SIDES OF A SPLICE BAR

# Single Phase Inverter with HD-Wave Technology

for North America

SE3000H-US / SE3800H-US / SE5000H-US / SE6000H-US /  
SE7600H-US / SE10000H-US / SE11400H-US



## Optimized installation with HD-Wave technology

- / Specifically designed to work with power optimizers
- / Record-breaking efficiency
- / Quick and easy inverter commissioning directly from a smartphone using the SolarEdge SetApp
- / Fixed voltage inverter for longer strings
- / Integrated arc fault protection and rapid shutdown for NEC 2014 and 2017, per article 690.11 and 690.12
- / UL1741 SA certified, for CPUC Rule 21 grid compliance
- / Extremely small
- / Built-in module-level monitoring
- / Outdoor and indoor installation
- / Optional: Revenue grade data, ANSI C12.20 Class 0.5 (0.5% accuracy)



# / Single Phase Inverter with HD-Wave Technology for North America

SE3000H-US / SE3800H-US / SE5000H-US / SE6000H-US/  
SE7600H-US / SE10000H-US / SE11400H-US

Model Number	SE3000H-US	SE3800H-US	SE5000H-US	SE6000H-US	SE7600H-US	SE10000H-US	SE11400H-US	
APPLICABLE TO INVERTERS WITH PART NUMBER	SEXXXXH-XXXXXXBX4							
<b>OUTPUT</b>								
Rated AC Power Output	3000	3800 @ 240V 3300 @ 208V	5000	6000 @ 240V 5000 @ 208V	7600	10000	11400 @ 240V 10000 @ 208V	VA
Maximum AC Power Output	3000	3800 @ 240V 3300 @ 208V	5000	6000 @ 240V 5000 @ 208V	7600	10000	11400 @ 240V 10000 @ 208V	VA
AC Output Voltage Min.-Nom.-Max. (211 - 240 - 264)	✓	✓	✓	✓	✓	✓	✓	Vac
AC Output Voltage Min.-Nom.-Max. (183 - 208 - 229)	-	✓	-	✓	-	-	✓	Vac
AC Frequency (Nominal)	59.3 - 60 - 60.5 <sup>(1)</sup>							Hz
Maximum Continuous Output Current @240V	12.5	16	21	25	32	42	47.5	A
Maximum Continuous Output Current @208V	-	16	-	24	-	-	48.5	A
Power Factor	1, adjustable -0.85 to 0.85							
GFDI Threshold	1							A
Utility Monitoring, Islanding Protection, Country Configurable Thresholds	Yes							
<b>INPUT</b>								
Maximum DC Power @240V	4650	5900	7750	9300	11800	15500	17650	W
Maximum DC Power @208V	-	5100	-	7750	-	-	15500	W
Transformer-less, Ungrounded	Yes							
Maximum Input Voltage	480							Vdc
Nominal DC Input Voltage	380				400			Vdc
Maximum Input Current @240V <sup>(2)</sup>	8.5	10.5	13.5	16.5	20	27	30.5	Adc
Maximum Input Current @208V <sup>(2)</sup>	-	9	-	13.5	-	-	27	Adc
Max. Input Short Circuit Current	45							Adc
Reverse-Polarity Protection	Yes							
Ground-Fault Isolation Detection	600k $\Omega$ Sensitivity							
Maximum Inverter Efficiency	99	99.2						%
CEC Weighted Efficiency	99						99 @ 240V 98.5 @ 208V	%
Nighttime Power Consumption	< 2.5							W

<sup>(1)</sup> For other regional settings please contact SolarEdge support

<sup>(2)</sup> A higher current source may be used; the inverter will limit its input current to the values stated

# / Single Phase Inverter with HD-Wave Technology for North America

SE3000H-US / SE3800H-US / SE5000H-US / SE6000H-US/  
SE7600H-US / SE10000H-US / SE11400H-US

Model Number	SE3000H-US	SE3800H-US	SE5000H-US	SE6000H-US	SE7600H-US	SE10000H-US	SE11400H-US	
<b>ADDITIONAL FEATURES</b>								
Supported Communication Interfaces	RS485, Ethernet, ZigBee (optional), Cellular (optional)							
Revenue Grade Data, ANSI C12.20	Optional <sup>(3)</sup>							
Inverter Commissioning	with the SetApp mobile application using built-in Wi-Fi Access Point for local connection							
Rapid Shutdown - NEC 2014 and 2017 690.12	Automatic Rapid Shutdown upon AC Grid Disconnect							
<b>STANDARD COMPLIANCE</b>								
Safety	UL1741, UL1741 SA, UL1699B, CSA C22.2, Canadian AFCI according to T.I.L. M-07							
Grid Connection Standards	IEEE1547, Rule 21, Rule 14 (HI)							
Emissions	FCC Part 15 Class B							
<b>INSTALLATION SPECIFICATIONS</b>								
AC Output Conduit Size / AWG Range	1" Maximum / 14-6 AWG			1" Maximum /14-4 AWG				
DC Input Conduit Size / # of Strings / AWG Range	1" Maximum / 1-2 strings / 14-6 AWG			1" Maximum / 1-3 strings / 14-6 AWG				
Dimensions with Safety Switch (HxWxD)	17.7 x 14.6 x 6.8 / 450 x 370 x 174			21.3 x 14.6 x 7.3 / 540 x 370 x 185			in / mm	
Weight with Safety Switch	22 / 10	25.1 / 11.4	26.2 / 11.9	38.8 / 17.6			lb / kg	
Noise	< 25			<50			dBA	
Cooling	Natural Convection							
Operating Temperature Range	-40 to +140 / -40 to +60 <sup>(4)</sup>							°F / °C
Protection Rating	NEMA 4X (Inverter with Safety Switch)							

<sup>(3)</sup> Revenue grade inverter P/N: SExxxxH-US000BNC4

<sup>(4)</sup> Full power up to at least 50°C / 122°F; for power de-rating information refer to: <https://www.solaredge.com/sites/default/files/se-temperature-derating-note-na.pdf>

# Q.PEAK DUO BLK-G6+ 330-345

ENDURING HIGH  
PERFORMANCE



#### Q.ANTUM TECHNOLOGY: LOW LEVELIZED COST OF ELECTRICITY

Higher yield per surface area, lower BOS costs, higher power classes, and an efficiency rate of up to 19.5%.



#### INNOVATIVE ALL-WEATHER TECHNOLOGY

Optimal yields, whatever the weather with excellent low-light and temperature behavior.



#### ENDURING HIGH PERFORMANCE

Long-term yield security with Anti LID and Anti PID Technology<sup>1</sup>, Hot-Spot Protect and Traceable Quality Tra.Q™.



#### EXTREME WEATHER RATING

High-tech aluminum alloy frame, certified for high snow (5400 Pa) and wind loads (4000 Pa).



#### A RELIABLE INVESTMENT

Inclusive 25-year product warranty and 25-year linear performance warranty<sup>2</sup>.



#### STATE OF THE ART MODULE TECHNOLOGY

Q.ANTUM DUO combines cutting edge cell separation and innovative wiring with Q.ANTUM Technology.

<sup>1</sup> APT test conditions according to IEC/TS 62804-1:2015, method B (-1500 V, 168 h)

<sup>2</sup> See data sheet on rear for further information

#### THE IDEAL SOLUTION FOR:



Rooftop arrays on  
residential buildings

## MECHANICAL SPECIFICATION

Format	68.5 × 40.6 × 1.26 in (including frame) (1740 × 1030 × 32 mm)
Weight	43.9 lbs (19.9 kg)
Front Cover	0.13 in (3.2 mm) thermally pre-stressed glass with anti-reflection technology
Back Cover	Composite film
Frame	Black anodized aluminum
Cell	6 × 20 monocrystalline Q.ANTUM solar half cells
Junction Box	2.09-3.98 × 1.26-2.36 × 0.59-0.71 in (53-101 × 32-60 × 15-18 mm), Protection class IP67, with bypass diodes
Cable	4 mm <sup>2</sup> Solar cable; (+) ≥45.3 in (1150 mm), (-) ≥45.3 in (1150 mm)
Connector	Stäubli MC4, Hanwha Q CELLS HQC4, Amphenol UTX, Renhe 05-6, Tongling TL-Cable01S, JMTHY JM601; IP68 or Friends PV2e; IP67

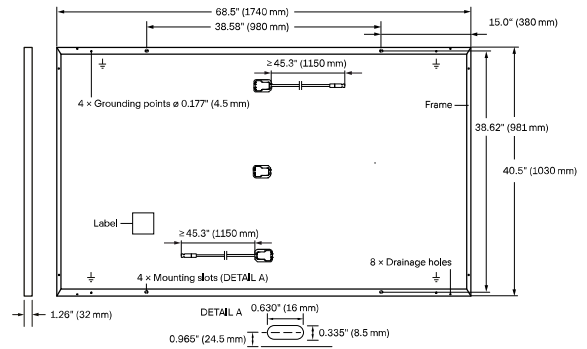

## ELECTRICAL CHARACTERISTICS

POWER CLASS		330	335	340	345	
MINIMUM PERFORMANCE AT STANDARD TEST CONDITIONS, STC <sup>1</sup> (POWER TOLERANCE +5 W / -0 W)						
Minimum	Power at MPP <sup>1</sup>	$P_{MPP}$ [W]	330	335	340	345
	Short Circuit Current <sup>1</sup>	$I_{SC}$ [A]	10.41	10.47	10.52	10.58
	Open Circuit Voltage <sup>1</sup>	$V_{OC}$ [V]	40.15	40.41	40.66	40.92
	Current at MPP	$I_{MPP}$ [A]	9.91	9.97	10.02	10.07
	Voltage at MPP	$V_{MPP}$ [V]	33.29	33.62	33.94	34.25
	Efficiency <sup>1</sup>	$\eta$ [%]	≥18.4	≥18.7	≥19.0	≥19.3
MINIMUM PERFORMANCE AT NORMAL OPERATING CONDITIONS, NMOT <sup>2</sup>						
Minimum	Power at MPP	$P_{MPP}$ [W]	247.0	250.7	254.5	258.2
	Short Circuit Current	$I_{SC}$ [A]	8.39	8.43	8.48	8.52
	Open Circuit Voltage	$V_{OC}$ [V]	37.86	38.10	38.34	38.59
	Current at MPP	$I_{MPP}$ [A]	7.80	7.84	7.89	7.93
	Voltage at MPP	$V_{MPP}$ [V]	31.66	31.97	32.27	32.57

<sup>1</sup>Measurement tolerances  $P_{MPP} \pm 3\%$ ;  $I_{SC}$ ;  $V_{OC} \pm 5\%$  at STC: 1000 W/m<sup>2</sup>, 25 ± 2 °C, AM 1.5 according to IEC 60904-3 • 800 W/m<sup>2</sup>, NMOT, spectrum AM 1.5

### Q CELLS PERFORMANCE WARRANTY

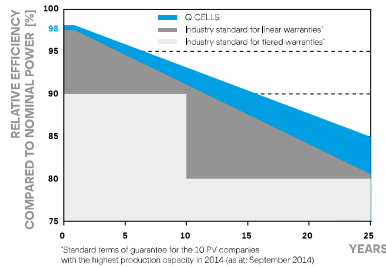

At least 98% of nominal power during first year. Thereafter max. 0.54% degradation per year. At least 93.1% of nominal power up to 10 years. At least 85% of nominal power up to 25 years.

All data within measurement tolerances. Full warranties in accordance with the warranty terms of the Q CELLS sales organization of your respective country.

### PERFORMANCE AT LOW IRRADIANCE

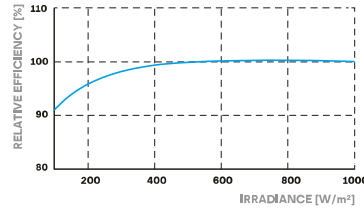

Typical module performance under low irradiance conditions in comparison to STC conditions (25 °C, 1000 W/m<sup>2</sup>)

### TEMPERATURE COEFFICIENTS

Temperature Coefficient of $I_{SC}$	$\alpha$ [% / K]	+0.04	Temperature Coefficient of $V_{OC}$	$\beta$ [% / K]	-0.27
Temperature Coefficient of $P_{MPP}$	$\gamma$ [% / K]	-0.36	Normal Module Operating Temperature	NMOT [°F]	109 ± 5.4 (43 ± 3 °C)

## PROPERTIES FOR SYSTEM DESIGN

Maximum System Voltage $V_{SYS}$	[V]	1000 (IEC)/1000 (UL)	Safety Class	II
Maximum Series Fuse Rating	[A DC]	20	Fire Rating based on ANSI / UL 1703	C (IEC) / TYPE 2 (UL)
Max. Design Load, Push / Pull <sup>3</sup>	[lbs / ft <sup>2</sup> ]	75 (3600 Pa) / 55 (2667 Pa)	Permitted Module Temperature on Continuous Duty	-40 °F up to +185 °F (-40 °C up to +85 °C)
Max. Test Load, Push / Pull <sup>3</sup>	[lbs / ft <sup>2</sup> ]	113 (5400 Pa) / 84 (4000 Pa)		

<sup>3</sup>See Installation Manual

## QUALIFICATIONS AND CERTIFICATES

UL 1703, VDE Quality Tested, CE-compliant, IEC 61215:2016, IEC 61730:2016, Application Class II, U.S. Patent No. 9,893,215 (solar cells)



## PACKAGING INFORMATION

Number of Modules per Pallet	32
Number of Pallets per 53' Trailer	28
Number of Pallets per 40' HC-Container	24
Pallet Dimensions (L × W × H)	71.5 × 45.3 × 48.0 in (1815 × 1150 × 1220 mm)
Pallet Weight	1505 lbs (683 kg)

**Note:** Installation instructions must be followed. See the installation and operating manual or contact our technical service department for further information on approved installation and use of this product.

Hanwha Q CELLS America Inc.

400 Spectrum Center Drive, Suite 1400, Irvine, CA 92618, USA | TEL +1 949 748 59 96 | EMAIL inquiry@us.q-cells.com | WEB www.q-cells.us



---

# Power Optimizer

For North America

P320 / P340 / P370 / P400 / P405 / P505



POWER OPTIMIZER

## PV power optimization at the module-level

- Specifically designed to work with SolarEdge inverters
- Up to 25% more energy
- Superior efficiency (99.5%)
- Mitigates all types of module mismatch losses, from manufacturing tolerance to partial shading
- Flexible system design for maximum space utilization
- Fast installation with a single bolt
- Next generation maintenance with module-level monitoring
- Meets NEC requirements for arc fault protection (AFCI) and Photovoltaic Rapid Shutdown System (PVRSS)
- Module-level voltage shutdown for installer and firefighter safety

# / Power Optimizer

## For North America

P320 / P340 / P370 / P400 / P405 / P505

Optimizer model (typical module compatibility)	P320 (for 60-cell modules)	P340 (for high-power 60-cell modules)	P370 (for higher-power 60 and 72-cell modules)	P400 (for 72 & 96-cell modules)	P405 (for thin film modules)	P505 (for higher current modules)	
<b>INPUT</b>							
Rated Input DC Power <sup>(1)</sup>	320	340	370	400	405	505	W
Absolute Maximum Input Voltage (Voc at lowest temperature)	48		60	80	125 <sup>(2)</sup>		Vdc
MPPT Operating Range	8 - 48		8 - 60	8 - 80	12.5 - 105	12.5 - 87	Vdc
Maximum Short Circuit Current (Isc)	11			10.1		14	Adc
Maximum DC Input Current	13.75			12.5		17.5	Adc
Maximum Efficiency	99.5						%
Weighted Efficiency	98.8					98.6	%
Overvoltage Category	II						
<b>OUTPUT DURING OPERATION (POWER OPTIMIZER CONNECTED TO OPERATING SOLAREEDGE INVERTER)</b>							
Maximum Output Current	15						Adc
Maximum Output Voltage	60				85		Vdc
<b>OUTPUT DURING STANDBY (POWER OPTIMIZER DISCONNECTED FROM SOLAREEDGE INVERTER OR SOLAREEDGE INVERTER OFF)</b>							
Safety Output Voltage per Power Optimizer	1 ± 0.1						Vdc
<b>STANDARD COMPLIANCE</b>							
EMC	FCC Part15 Class B, IEC61000-6-2, IEC61000-6-3						
Safety	IEC62109-1 (class II safety), UL1741						
Material	UL94 V-0, UV Resistant						
RoHS	Yes						
<b>INSTALLATION SPECIFICATIONS</b>							
Maximum Allowed System Voltage	1000						Vdc
Compatible inverters	All SolarEdge Single Phase and Three Phase inverters						
Dimensions (W x L x H)	129 x 153 x 27.5 / 5.1 x 6 x 1.1			129 x 153 x 33.5 / 5.1 x 6 x 1.3	129 x 159 x 49.5 / 5.1 x 6.3 x 1.9	129 x 162 x 59 / 5.1 x 6.4 x 2.3	mm / in
Weight (including cables)	630 / 1.4			750 / 1.7	845 / 1.9	1064 / 2.3	gr / lb
Input Connector	Single or dual MC4 <sup>(3)</sup>						
Input Wire Length	0.16 / 0.52						m / ft
Output Wire Type / Connector	Double Insulated / MC4						
Output Wire Length	0.9 / 2.95			1.2 / 3.9			m / ft
Operating Temperature Range	-40 - +85 / -40 - +185						°C / °F
Protection Rating	IP68 / NEMA6P						
Relative Humidity	0 - 100						%

<sup>(1)</sup> Rated power of the module at STC will not exceed the optimizer "Rated Input DC Power". Modules with up to +5% power tolerance are allowed

<sup>(2)</sup> NEC 2017 requires max input voltage be not more than 80V

<sup>(3)</sup> For other connector types please contact SolarEdge

PV System Design Using a SolarEdge Inverter <sup>(4)(5)</sup>	Single Phase HD-Wave	Single phase	Three Phase 208V	Three Phase 480V	
Minimum String Length (Power Optimizers)	P320, P340, P370, P400	8	10	18	
	P405 / P505	6	13 (12 with SE3K)	14	
Maximum String Length (Power Optimizers)		25	25	50 <sup>(6)</sup>	
Maximum Power per String	5700 (6000 with SE7600-US - SE11400-US)	5250	6000 <sup>(7)</sup>	12750 <sup>(8)</sup>	W
Parallel Strings of Different Lengths or Orientations	Yes				

<sup>(4)</sup> For detailed string sizing information refer to: [http://www.solaredge.com/sites/default/files/string\\_sizing\\_na.pdf](http://www.solaredge.com/sites/default/files/string_sizing_na.pdf)

<sup>(5)</sup> It is not allowed to mix P405/P505 with P320/P340/P370/P400 in one string

<sup>(6)</sup> A string with more than 30 optimizers does not meet NEC rapid shutdown requirements; safety voltage will be above the 30V requirement

<sup>(7)</sup> For SE14.4KUS/SE43.2KUS: It is allowed to install up to 6,500W per string when 3 strings are connected to the inverter (3 strings per unit for SE43.2KUS) and when the maximum power difference between the strings is up to 1,000W

<sup>(8)</sup> For SE30KUS/SE33.3KUS/SE66.6KUS/SE100KUS: It is allowed to install up to 15,000W per string when 3 strings are connected to the inverter (3 strings per unit for SE66.6KUS/SE100KUS) and when the maximum power difference between the strings is up to 2,000W

RSTC Enterprises, Inc.  
2214 Heimstead Road  
Eau Claire, WI 54703  
715-830-9997



## Outdoor Photovoltaic Enclosures

Composition/Cedar Roof System

### ETL listed and labeled

Report # 3171411PRT-002 Revised May, 2018

- UL50 Type 3R, 11 Edition Electrical equipment enclosures
- CSA C22.2 No. 290 Nema Type 3R
- Conforms to UL 1741 Standard

### 0799 Series Includes:

- |          |                  |
|----------|------------------|
| 0799 - 2 | Wire size 2/0-14 |
| 0799 - 5 | Wire size 14-6   |
| 0799 - D | Wire size 14-8   |

Models available in Grey, Black or Stainless Steel

### Basic Specifications

Material options:

- Powder coated, 18 gauge galvanized 90 steel (1,100 hours salt spray)
- Stainless steel

Process - Seamless draw (stamped)

Flashing - 15.25" x 17.25"

Height - 3"

Cavity - 255 Cubic inches

### Base Plate:

- Fastened to base using toggle fastening system
- 5 roof deck knockouts
- Knockout sizes: (3) .5", (1) .75" and (1) 1"
- 8", 35mm slotted din rail
- Ground Block

Passthrough and combiner kits are available for either AC or DC applications.

## 0799 Series



**Product data sheet**  
Characteristics

# D222NRB

Safety switch, general duty, fusible, 60A, 2 poles, 15 hp, 120 VAC, NEMA 3R, bolt-on provision, neutral factory installed

Product availability : Stock - Normally stocked in distribution facility



Price\* : 326.00 USD



### Main

Product	Single Throw Safety Switch
Current Rating	60 A
Certifications	UL listed file E2875
Enclosure Rating	NEMA 3R
Disconnect Type	Fusible disconnect switch
Factory Installed Neutral	Neutral (factory installed)
Short Circuit Current Rating	100 kA maximum depending on fuse H, K or R
Mounting Type	Surface
Number of Poles	2
Electrical Connection	Lugs
Duty Rating	General duty
Voltage Rating	240 V AC
Wire Size	AWG 12...AWG 3 aluminium AWG 14...AWG 3 copper

### Complementary

Maximum Horse Power Rating	1.5 hp 120 V AC 60 Hz 1 phase NEC 240.6 3 hp 120 V AC 60 Hz 3 phase NEC 430.52 3 hp 240 V AC 60 Hz 1 phase NEC 240.6 7.5 hp 240 V AC 60 Hz 3 phase NEC 240.6 10 hp 240 V AC 60 Hz 1 phase NEC 430.52 15 hp 240 V AC 60 Hz 3 phase NEC 430.52
Width	7.45 in (189.23 mm)
Height	14.88 in (377.95 mm)
Depth	4.87 in (123.70 mm)

\* Price is "List Price" and may be subject to a trade discount – check with your local distributor or retailer for actual price.



Tightening torque	35 lbf.in (3.95 N.m) 0.00...0.01 in <sup>2</sup> (2.08...5.26 mm <sup>2</sup> ) AWG 14...AWG 10) 35 lbf.in (3.95 N.m) AWG 14...AWG 10) 45 lbf.in (5.08 N.m) 0.01 in <sup>2</sup> (8.37 mm <sup>2</sup> ) AWG 8) 45 lbf.in (5.08 N.m) 0.02...0.03 in <sup>2</sup> (12.3...21.12 mm <sup>2</sup> ) AWG 6...AWG 4) 50 lbf.in (5.65 N.m) 0.04 in <sup>2</sup> (26.67 mm <sup>2</sup> ) AWG 3)
-------------------	---

## Ordering and shipping details

Category	00106 - D & DU SW,NEMA3R, 30-200A
Discount Schedule	DE1A
GTIN	00785901460640
Package weight(Lbs)	8.25 lb(US) (3.74 kg)
Returnability	Yes
Country of origin	US

## Packing Units

Package 2 Weight	1022.00 lb(US) (463.571 kg)
------------------	-----------------------------

## Offer Sustainability

Sustainable offer status	Green Premium product
California proposition 65	WARNING: This product can expose you to chemicals including: Lead and lead compounds, which is known to the State of California to cause cancer and birth defects or other reproductive harm. For more information go to <a href="http://www.P65Warnings.ca.gov">www.P65Warnings.ca.gov</a>
REACH Regulation	<a href="#">REACH Declaration</a>
REACH free of SVHC	Yes
EU RoHS Directive	Compliant <a href="#">EU RoHS Declaration</a>
Mercury free	Yes
RoHS exemption information	<a href="#">Yes</a>
China RoHS Regulation	<a href="#">China RoHS declaration</a> Product out of China RoHS scope. Substance declaration for your information.
Environmental Disclosure	<a href="#">Product Environmental Profile</a>
PVC free	Yes

## Contractual warranty

Warranty	18 months
----------	-----------



Connections and Wiring Diagrams

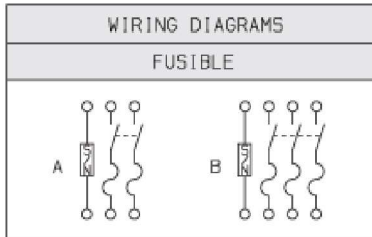

TERMINAL LUGS †			
AMPERES	MAX. WIRE	MIN. WIRE	TYPE
60	# 3 AWG	# 14 AWG	CU OR AL

† LUGS SUITABLE FOR 60°C OR 75°C CONDUCTORS.

CATALOG NUMBER	VOLTAGE RATINGS	WIRING DIAG.	AMPERE RATING	HORSEPOWER RATINGS			
				240VAC			
				STD.		MAX.	
				1 Ø	3 Ø	1 Ø	3 Ø
D222NRB	240VAC	A	60	3	7.50 ●	10	15 ●
D322NRB	240VAC	B	60	3 ✱	7.50	10	15

✱ USE OUTER SWITCHING POLES.

● FOR CORNER GROUNDED DELTA SYSTEMS ONLY.

# FLUSH MOUNT

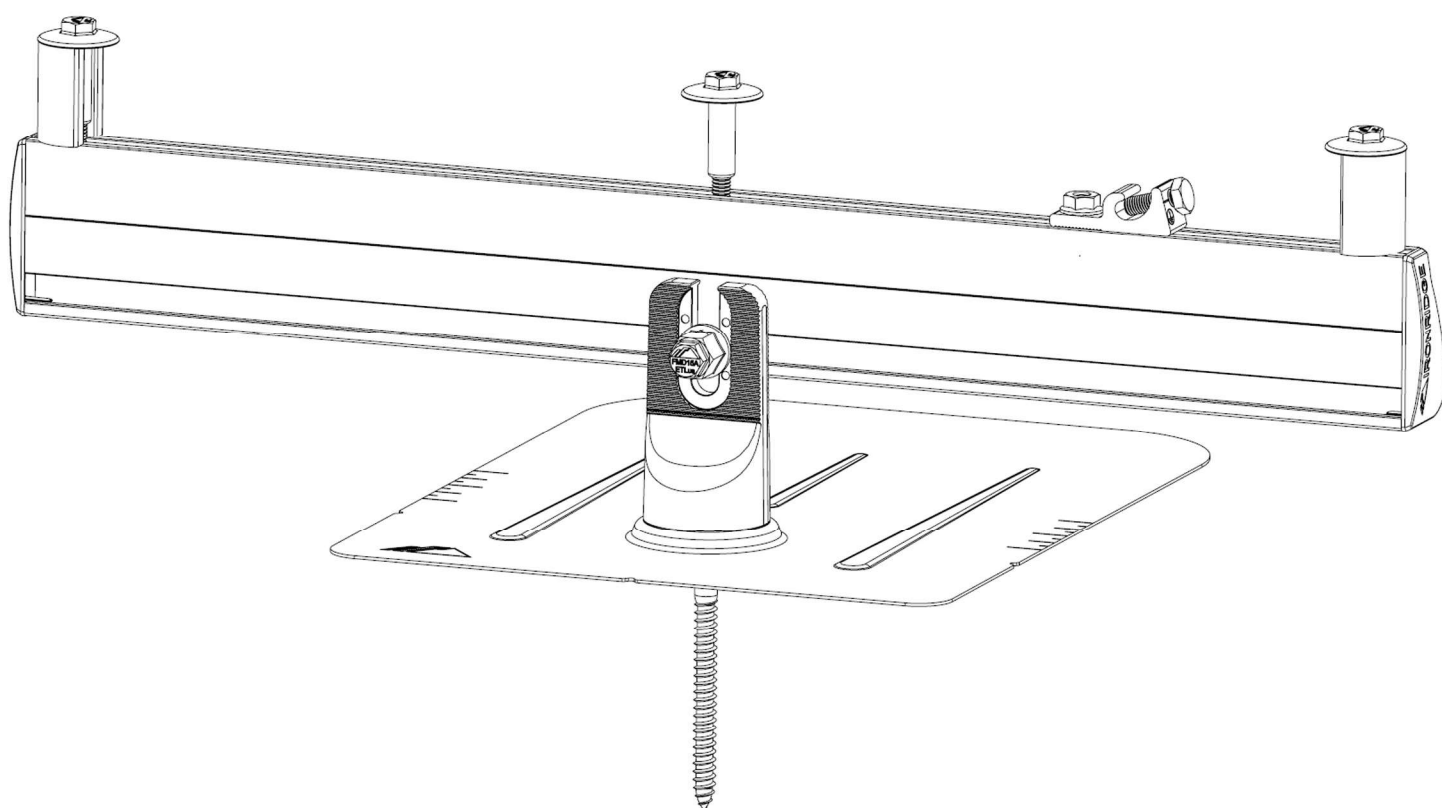



# CONTENTS

<b>DISCLAIMER</b>	<b>1</b>
<b>RATINGS</b>	<b>2</b>
<b>MARKINGS</b>	<b>2</b>
<b>CHECKLIST</b>	<b>3</b>
<b>1. ATTACH BASES</b>	<b>4</b>
<b>2. PLACE RAILS</b>	<b>4</b>
<b>3. SECURE LUGS</b>	<b>5</b>
<b>4. SECURE MODULES</b>	<b>5</b>
<b>CAMO</b>	<b>6</b>
<b>EXPANSION JOINTS</b>	<b>7</b>
<b>ELECTRICAL DIAGRAM</b>	<b>7</b>
<b>FLASHFOOT2</b>	<b>8</b>
<b>ALL TILE HOOK</b>	<b>8</b>
<b>KNOCKOUT TILE</b>	<b>8</b>
<b>FLAT ROOF ATTACHMENT</b>	<b>9</b>
<b>END CAPS</b>	<b>9</b>
<b>WIRE CLIPS</b>	<b>9</b>
<b>FLUSH STANDOFFS</b>	<b>9</b>
<b>MICROINVERTER KITS</b>	<b>10</b>
<b>SYSTEMS USING ENPHASE MICROINVERTERS OR SUNPOWER AC MODULES</b>	<b>10</b>
<b>SYSTEMS USING PHAZR MICROSTORAGE PRODUCTS</b>	<b>10</b>
<b>FRAMELESS MODULE KITS</b>	<b>11</b>
<b>MODULE COMPATIBILITY</b>	<b>11</b>

## DISCLAIMER

This manual describes proper installation procedures and provides necessary standards required for product reliability. Warranty details are [available on website](#). All installers must thoroughly read this manual and have a clear understanding of the installation procedures prior to installation. Failure to follow these guidelines may result in property damage, bodily injury or even death.

### IT IS THE INSTALLER'S RESPONSIBILITY TO:

- Ensure safe installation of all electrical aspects of the array. All electrical installation and procedures should be conducted by a licensed and bonded electrician or solar contractor. Routine maintenance of a module or panel shall not involve breaking or disturbing the bonding path of the system. All work must comply with national, state and local installation procedures, product and safety standards.
- Comply with all applicable local or national building and fire codes, including any that may supersede this manual.
- Ensure all products are appropriate for the installation, environment, and array under the site's loading conditions.
- Use only IronRidge parts or parts recommended by IronRidge; substituting parts may void any applicable warranty.
- Review the [Design Assistant](#) and [Certification Letters](#) to confirm design specifications.
- Ensure provided information is accurate. Issues resulting from inaccurate information are the installer's responsibility.
- Ensure bare copper grounding wire does not contact aluminum and zinc-plated steel components, to prevent risk of galvanic corrosion.
- If loose components or loose fasteners are found during periodic inspection, re-tighten immediately. If corrosion is found, replace affected components immediately.
- Provide an appropriate method of direct-to-earth grounding according to the latest edition of the National Electrical Code, including NEC 250: Grounding and Bonding, and NEC 690: Solar Photovoltaic Systems.
- Disconnect AC power before servicing or removing modules, AC modules, microinverters and power optimizers.
- Review module manufacturer's documentation for compatibility and compliance with warranty terms and conditions.

## RATINGS

### UL 2703 LISTED



**Intertek**

- Conforms to STD UL 2703 (2015) Standard for Safety First Edition: Mounting Systems, Mounting Devices, Clamping/Retention Devices, and Ground Lugs for Use with Flat-Plate Photovoltaic Modules and Panels.
- Max Overcurrent Protective Device (OCPD) Rating: 25A
- Max Module Size: 24ft<sup>2</sup>
- Module Orientation: Portrait or Landscape
- CAMO Specific Allowable Design Load Rating: 50 PSF downward, 50 PSF upward, 15 PSF lateral
- System Level Allowable Design Load Rating: meets minimum requirements of the standard (10 PSF downward, 5 PSF upward, 5 PSF lateral). Actual system structural capacity is defined by PE stamped [certification letters](#).

### CLASS A SYSTEM FIRE RATING PER UL 1703

- Any Roof Slope with Module Types 1, 2, and 3
- Any module-to-roof gap is permitted, with no perimeter guarding required. This rating is applicable with any third-party attachment.
- Class A rated PV systems can be installed on Class A, B, and C roofs without affecting the roof fire rating.

### WATER SEAL RATINGS: UL 441 & TAS 100(A)-95 (FLASHFOOT2, ALL TILE HOOK, KNOCKOUT TILE)

- Tested and evaluated without sealant.
- Any roofing manufacturer approved sealant is allowed. Ratings applicable for roof slopes between 2:12 and 12:12

### STRUCTURAL CERTIFICATION

- Designed and Certified for Compliance with the International Building Code & ASCE/SEI-7

## MARKINGS

Product markings are located on the 3/8" flange hex nut or Grounding Lug bolt head.

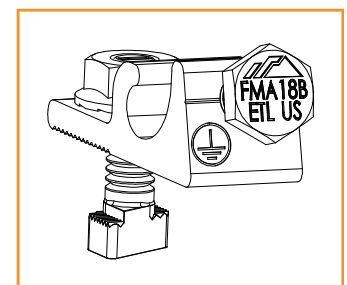
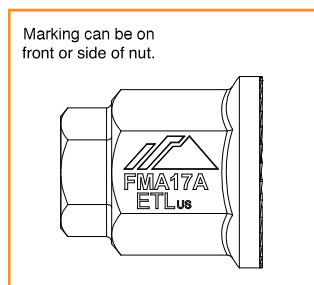
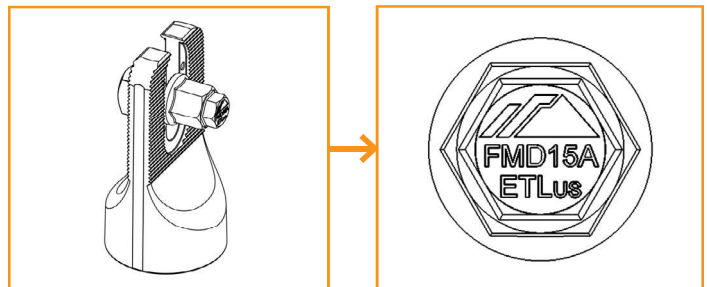

# CHECKLIST

## PRE-INSTALLATION

- Verify module compatibility. See [Page 10](#) for info.

## TOOLS REQUIRED

- Cordless Drill (non-impact)
- Impact Driver (for lag bolts)
- Torque Wrench (0-250 in-lbs)
- 5/16" Socket
- 7/16" Socket
- 1/2" Socket
- String Line

## TORQUE VALUES

- FlashFoot2 Lag Bolts (7/16" Socket): Fully Seat
- Bonded Splice Screws (5/16" Socket): 20 in-lbs
- Grounding Lug Nuts (7/16" Socket): 80 in-lbs
- Grounding Lug Terminal Screws (7/16" Socket): 20 in-lbs
- Universal Fastening Object (7/16" Socket): 80 in-lbs
- Expansion Joint Nuts (7/16" Socket): 80 in-lbs
- Flush Standoffs (1/2" Socket): 132 in-lbs
- Microinverter Kit Nuts (7/16" Socket): 80 in-lbs
- Frameless Module Kit Nuts (7/16" Socket): 80 in-lbs
- 3/8" Bonding Hardware Nuts (7/16" Socket): 250 in-lbs
- All Tile Hook Lags (7/16" Socket): Fully Seat
- All Tile Hook Carriage Bolts (7/16" Socket): 132 in-lbs
- Knockout Tile Lags (1/2" Socket): Fully Seat
- Knockout Tile Nuts (1/2" Socket): 132 in-lbs
- Flat Roof Attachment Nuts (9/16" Socket): 250 in-lbs

💡 If using previous version of: FlashFoot, Integrated Grounding Mid Clamps, Grounding Lug, End Clamps, and Expansion Joints please refer to Alternate Components Addendum (Version 1.20).

## IRONRIDGE COMPONENTS

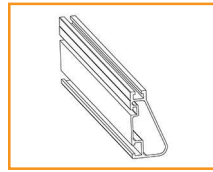

XR Rail

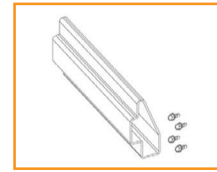

Bonded Splice

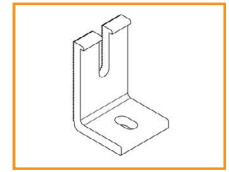

L-Foot

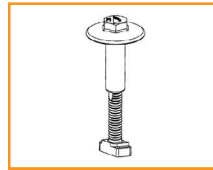

UFO

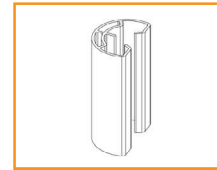

Stopper Sleeve

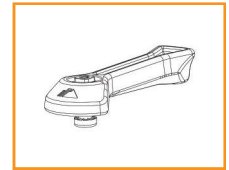

CAMO

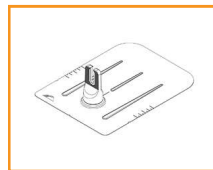

FlashFoot2

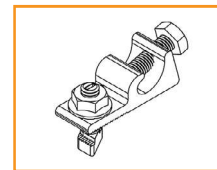

Grounding Lug

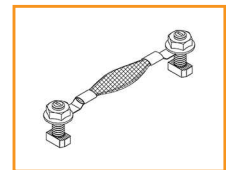

Expansion Joint



End Cap



Wire Clip



Flush Standoff

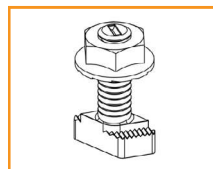

Microinverter Kit

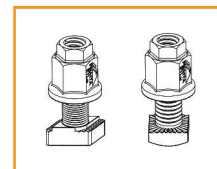

3/8" Bonding Hardware

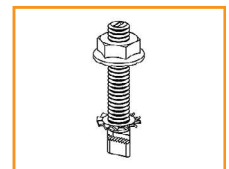

Frameless Module Kit

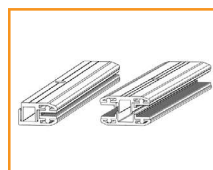

Frameless End/Mid Clamp

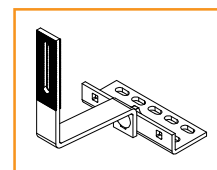

All Tile Hook

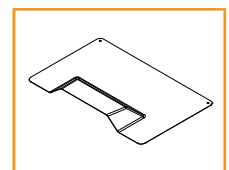

All Tile Hook Flashing

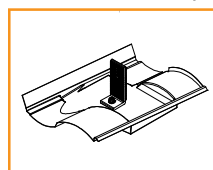

Knockout Tile

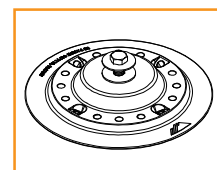

Flat Roof Attachment

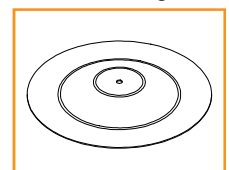

Membrane Flashing

# 1. ATTACH BASES

For composition roofs, refer to FlashFoot2 install instructions on [page 8](#). For tile roofs, refer to All Tile Hook and Knockout Tile install instructions on [page 8](#) and [9](#). For flat roofs, refer to Flat Roof Attachment install instructions on [page 9](#). When using approved third party attachments, refer to manufacturer's install instructions.

💡 **Tested or evaluated third-party roof attachments:**

- [Anchor Products](#) - U-Anchor
- [S-5! Standing Seam Metal Roof Clamps](#) - Certification of metal roof clamps includes bonding to both painted and galvalume metal roofs. Tighten S-5! and S-5! Mini set screws to 130-150 in-lbs ( $\geq 24$  gauge) or 160-180 in-lbs (22 gauge) roofs. Tighten S-5! M10 bolt to 240 in-lbs or S-5! Mini M8 bolt to 160 in-lbs. Use the following fastening guidelines for other S-5! roof clamps: ProteaBracket™ - firmly seat roof screws and tighten hinge bolt to 225 in-lbs; RibBracket™ - firmly seat roof screws and tighten M8 bolt (M8-1.25 x 22mm sold separately) to 160 in-lbs; and SolarFoot™ - firmly seat roof screws and tighten M8 flange nut to 160 in-lbs.
- [EcoFasten Green Fasten GF-1 Anchors](#)
- Rooftech RT-Mini - Attach to L-foot using 5/16-18 x 1.25" stainless steel bolt and nut torqued to 132 in-lbs.
- QuickMount PV [Roof Mounts](#) QMLM/QMLM - ST and [Tile Hooks](#) - Tile Hook attaches to XR Rail using 3/8" Bonding Hardware Kit torqued to 250 in-lbs.
- Quickscrews Solar Roof Hooks, Ejot Aluminum Roof Hooks, Unirac Creotecc Tile Hooks, or Solarhooks - Attach to XR Rails with L-Foot or 3/8" Bonding Hardware Kit torqued to 250 in-lbs.
- Pegasus Comp Mount - Attach to XR Rail using 3/8" Bonding Hardware kit torqued to 250 in-lbs.

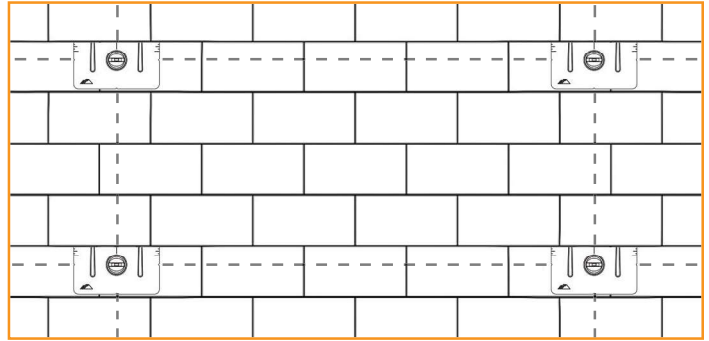

# 2. PLACE RAILS

## A. CONNECT SPLICES

Use Bonded Splices, when needed, to join multiple sections of rail. Insert Bonded Splice 6" into first rail and secure with two self-drilling screws, spacing them approximately 1" apart and tightening to **20 in-lbs**. Slide second rail over Bonded Splice and secure with two more self-drilling screws.

💡 Rows exceeding 100 feet of rail must use [Expansion Joints](#).

💡 For XR10 and XR100 rails, insert screws along the provided lines.

💡 Refer to [Structural Certification letters](#) for rail splice location requirements.

💡 Screws can be inserted on front or back of rails.

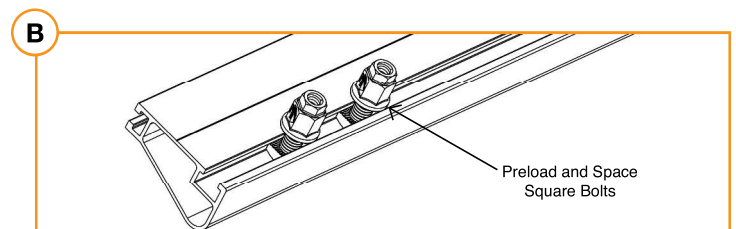
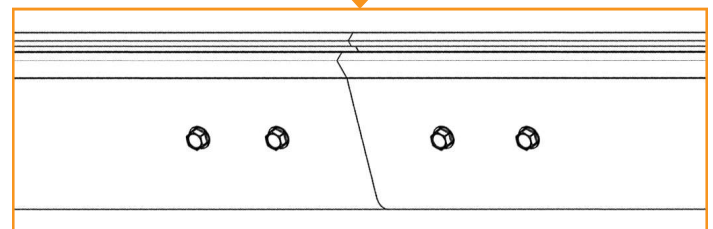
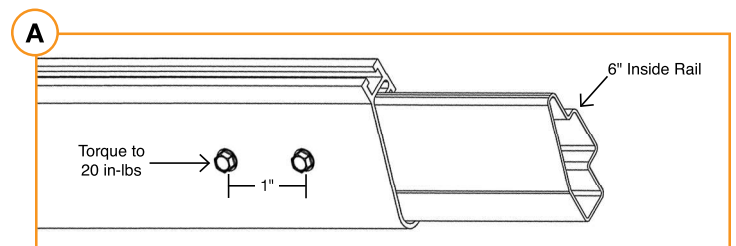

## B. PREPARE HARDWARE

Slide square-headed bolts into side-facing rail slot. Space out bolts to match attachment spacing.

💡 Tape ends of rail, to keep bolts from sliding out while moving.

💡 If using T-bolts, carry hardware onto roof and proceed.

## C. ATTACH RAILS

Drop rail with hardware into roof attachment. Level rail at desired height, then torque to **250 in-lbs**.

💡 Rail can face either upslope or downslope on roof.

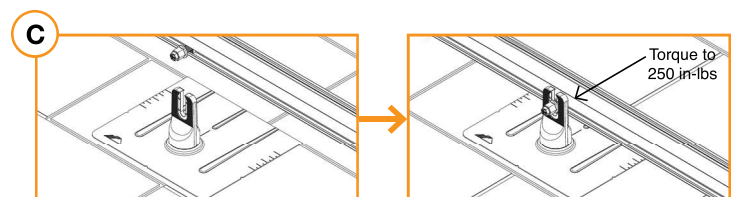

### 3. SECURE LUGS

Insert T-bolt in top rail slot and torque hex nut to **80 in-lbs**. Install a minimum 10 AWG solid copper or stranded grounding wire. Torque terminal screw to **20 in-lbs**.

- ⚡ Ground Lugs are only needed on one rail per continuous row of modules, regardless of row length (unless frameless modules are being used, see [Page 9](#)).
- ⚡ If using Enphase microinverters or Sunpower AC modules, Grounding Lugs may not be needed. See [Page 9](#) for more info.
- ⚡ Grounding Lugs can be installed anywhere along the rail and in either orientation shown. If installing lug underneath modules in areas with ground snow loads greater than 40 psf, place lug within 4 inches module frame edge.

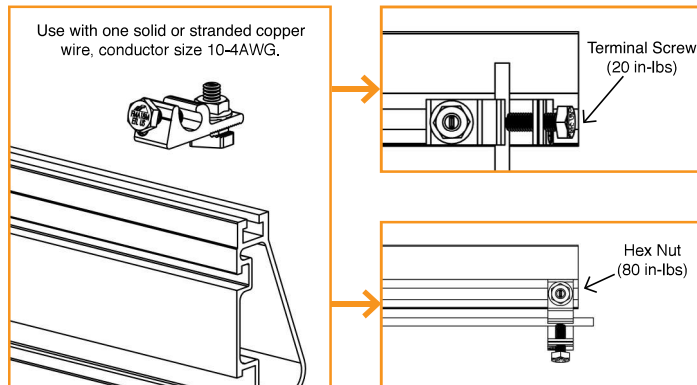

### 4. SECURE MODULES

#### A. SECURE FIRST END

Place first module in position on rails, a minimum of 1" from rail ends. Snap Stopper Sleeves onto UFO. Fasten module to rail using the UFO, ensuring that the UFO is hooked over the top of the module. Torque to **80 in-lbs**.

- ⚡ Ensure rails are square before placing modules.
- ⚡ Hold Stopper Sleeves on end while torquing to prevent rotation.
- ⚡ If using CAMO instead of UFO + Stopper Sleeve, refer to [Page 6](#) for CAMO installation procedure.

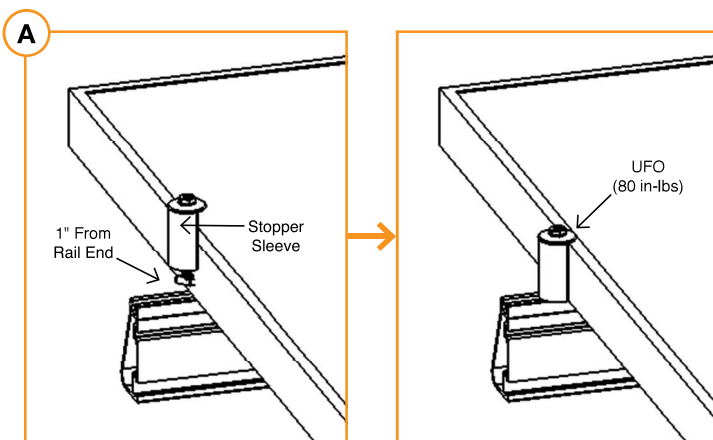

#### B. SECURE NEXT MODULES

Place UFO into each rail, placing them flush against first module. Slide second module against UFO. Torque to **80 in-lbs**. Repeat for each following module.

- ⚡ When reinstalling UFO, move modules a minimum of 1/16" so UFOs are in contact with a new section of module frame.
- ⚡ When UFOs are loosened and re-tightened, ensure UFO T-bolt bottoms out in rail channel before re-torquing UFO to achieve full engagement between T-bolt and rail.
- ⚡ If using Wire Clips, refer to [Page 9](#).

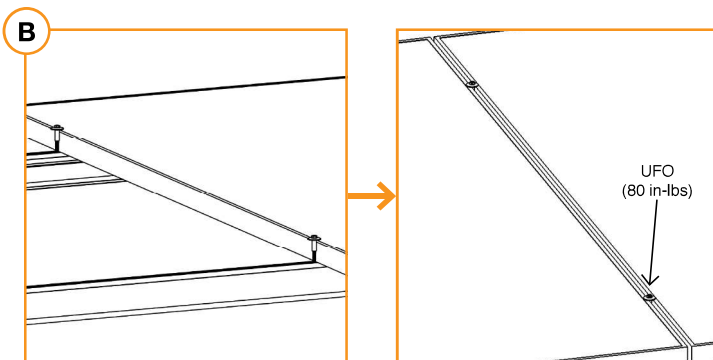

#### C. SECURE LAST END

Place last module in position on rails, a minimum of 1" from rail ends. Snap Stopper Sleeves onto UFO. Secure UFO Clamps on rails, ensuring they are hooked over top of module. Torque to **80 in-lbs**.

- ⚡ Hold Stopper Sleeves on end while torquing to prevent rotation.
- ⚡ Repeat all steps for each following row of modules, leaving a minimum 3/8" gap between rows.
- ⚡ If using CAMO instead of UFO + Stopper Sleeve, refer to [Page 6](#) for CAMO installation procedure.

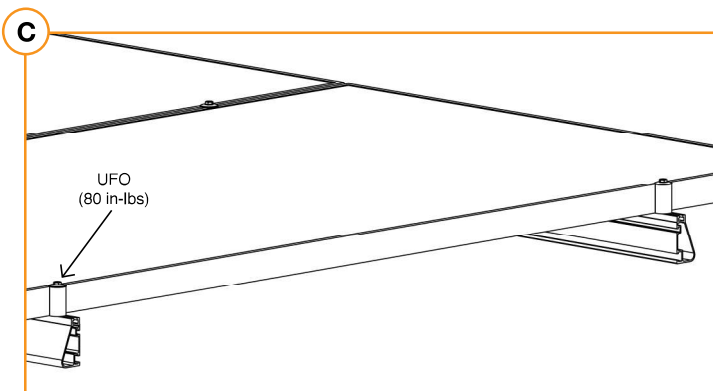



## A. SLIDE INTO RAIL

Slide CAMO into rail channel far enough to clear the module frame. CAMO requires 6" of clearance from end of rail.

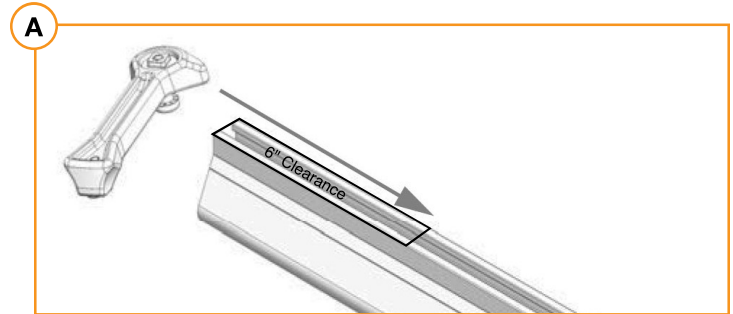

## B. PLACE MODULE

Place module on rails (module cells not shown for clarity). When installing CAMO the module can overhang the rail no more than 1/4".



## C. PULL TOWARDS END

Pull CAMO towards rail ends, at 45 degree angle, so the bonding bolt contacts the module flange edge.

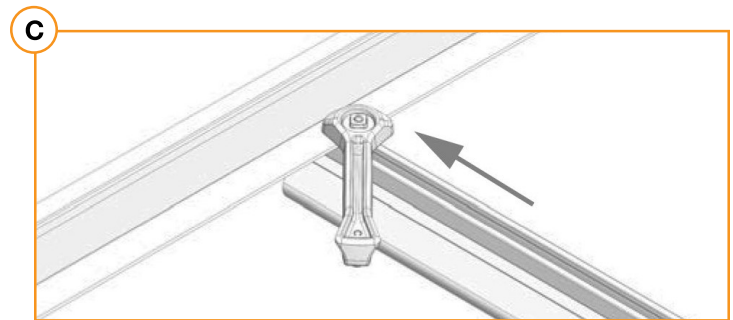

## D. SECURE TO FRAME

Rotate handle with an upwards motion until CAMO snaps into rail channel. Ensure CAMO bonding pins are fully seated on top of module frame.

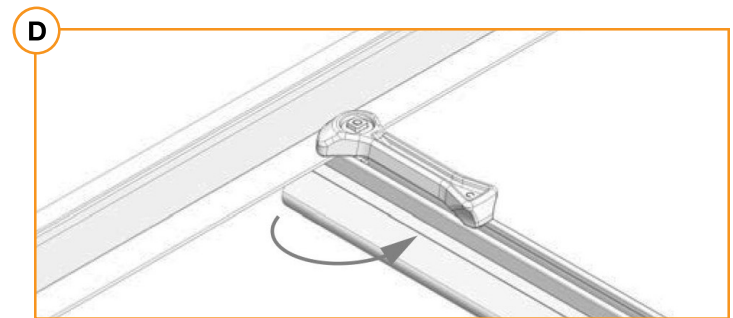

## FRAME COMPATIBILITY

CAMO has been tested or evaluated with all modules listed in the Module Compatibility section having frames within the referenced dimensions. Be sure the specific module being used meets the dimension requirements.

💡 For installations with Hanwha Q CELLS modules with 32 mm frame heights, the maximum ground snow is 45 PSF (33 PSF module pressure).

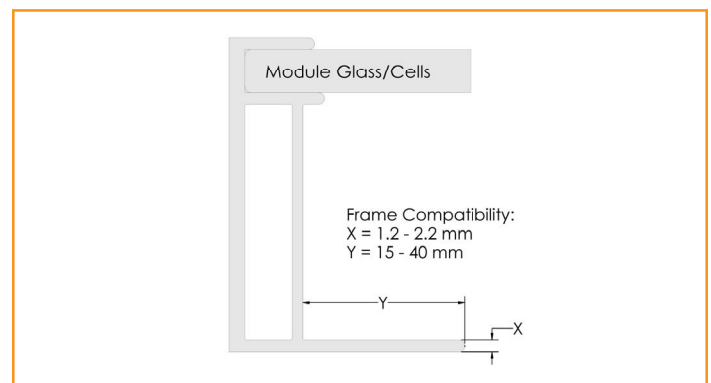



## EXPANSION JOINTS

### GROUNDING STRAP EXPANSION JOINT

Grounding Strap Expansion Joints are required for thermal expansion of rows exceeding 100 feet of rail.

Insert Internal Splice into first rail and secure with screw. Assemble and secure Grounding Strap 3/8" from rail end. Slide second rail over Internal Splice leaving 1" gap between rails. Attach other end of Grounding Strap with hardware, and torque hex nuts to **80 in-lbs**.

💡 **Second Bonded Splice screw is not used with Expansion Joints.**

💡 **Do not install module over top of expansion joint location.**

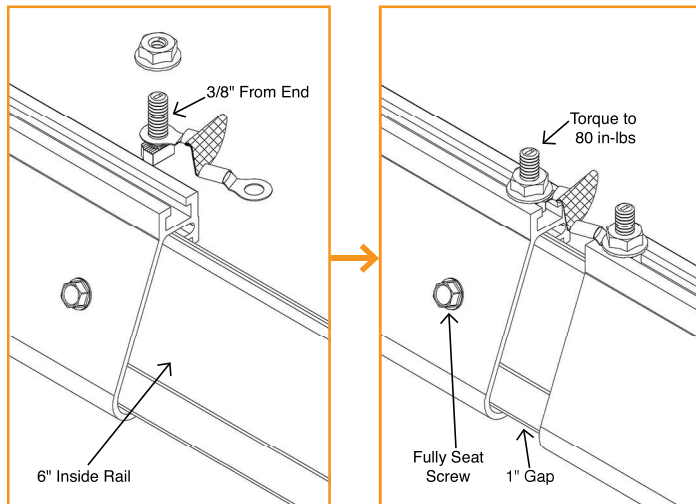

## ELECTRICAL DIAGRAM

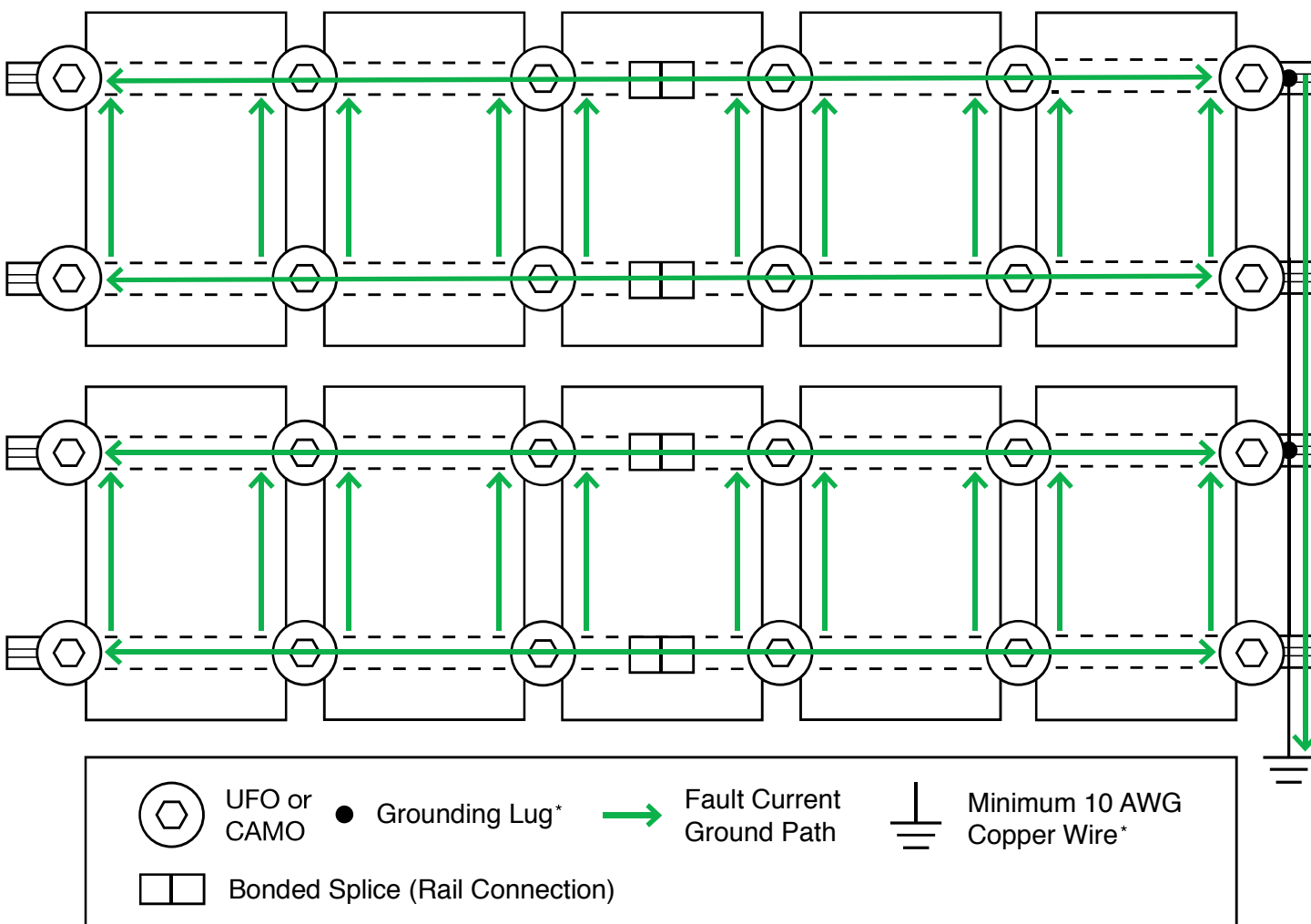

\*Grounding Lugs and wire are not required in systems using certain Enphase microinverters or certain Sunpower modules. Equipment grounding is achieved with the Engage cable for Enphase or the AC module cable system for Sunpower via their integrated EGC.

## FLASHFOOT2

Locate roof rafters and mark locations on roof. Drill 1/4" pilot holes and backfill with approved sealant. Slide flashing between 1st and 2nd course of shingles, ensuring flashing doesn't overhang the downhill shingle. Line up with pilot hole and insert supplied lag bolt with washer through flashing. Fully seat lag bolt. Place Cap onto flashing in desired orientation for E/W or N/S rails and rotate 180 degrees until it locks into place.

💡 Rail can be installed on either side of FlashFoot2 Cap.

💡 Standalone [FlashFoot2 manual](#) available on website.

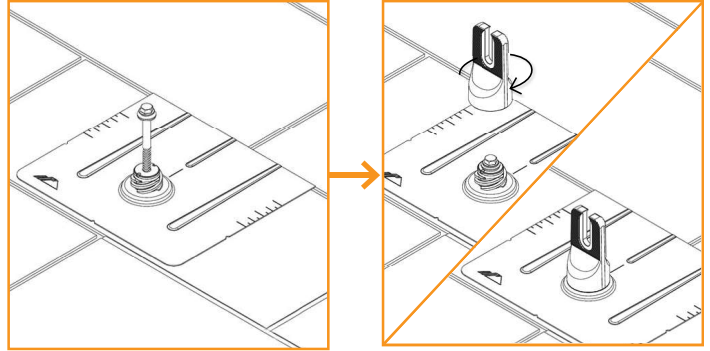

## ALL TILE HOOK

Remove tile and mark rafter. Position base over rafter, adjust arm if necessary and torque hardware to **132 in-lbs (11 ft-lbs)**. Use base as guide to drill 1/4" pilot holes, back fill with roofing manufacturer's approved sealant, then insert lag bolts and tighten until fully seated. Replace tiles and notch as necessary to ensure proper fit. Attach rails to either side of slot using bonding hardware and torque to **250 in-lbs (21-ft-lbs)**.

💡 Position arm near the center of valley for curved tiles.

💡 Position arm away from seam of joining flat tiles.

💡 Ensure top of hook does not extend above rail.

💡 IronRidge offers an optional aluminum deck flashing. Refer to **All Tile Hook Flashing Installation Manual**. Other approved flashing methods include user supplied adhesive backed flexible flashing.

💡 Standalone [All Tile Hook manual](#) available on website.

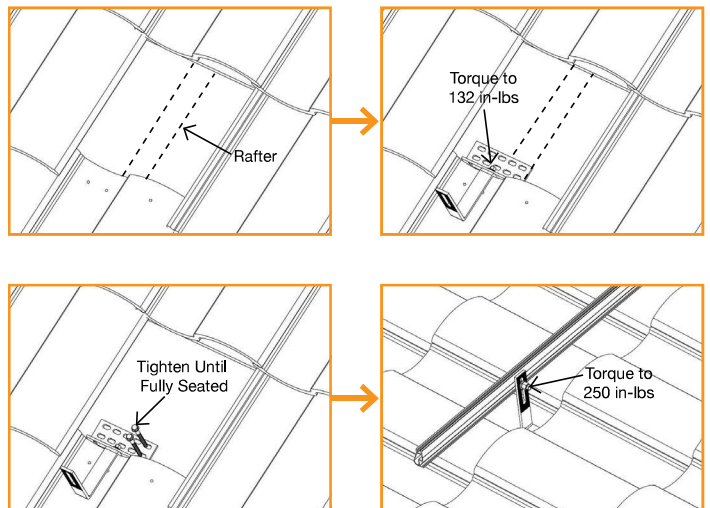

## KNOCKOUT TILE

Remove tile and mark rafter. Use base as guide to drill 1/4" pilot hole and fill with roofing manufacturer's approved sealant. Insert lag bolt with bonded washer through base and drive until fully seated. Insert Tile Replacement Flashing, lower onto base and apply pressure over the threaded post until it dimples the flashing. Place L-Foot over dimple and tap with hammer to punch threaded post through the flashing. Ensure punched pieces of flashing are cleared away. Form flashing as needed to sit flush with surrounding tiles, position L-Foot in desired orientation and torque hardware to **132 in-lbs (11 ft-lbs)**. Attach rail to either side of L-Foot with bonding hardware and torque to **250 in-lbs (21 ft-lbs)**.

💡 Base can be installed parallel or perpendicular to rafter.

💡 L-foot can be installed facing any direction.

💡 Ensure L-Foot does not extend above rail.

💡 If deck level flashing is required, approved flashing methods include user supplied adhesive backed flexible flashing.

💡 Standalone [Knockout Tile manual](#) available on website.

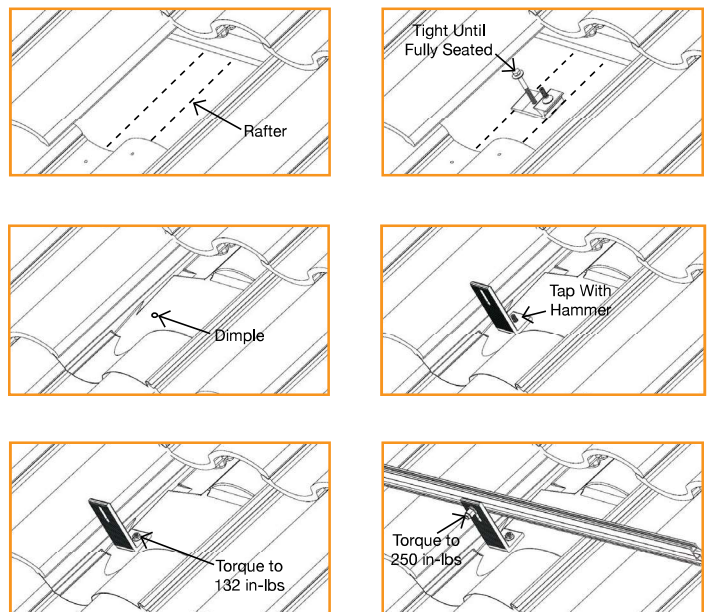

## FLAT ROOF ATTACHMENT

Flat Roof Attachment can be used with an L-foot for flush mounting modules on low sloped roofs. Mark locations for Flat Roof Attachment. Screws should be installed symmetrically to each other. If using a membrane flashing, remove the silicone washer's protective liner prior to attaching the membrane. Attach L-foot with washers and 3/8" hardware torqued to **250 in-lbs (21 ft-lbs)**. Seal attachment and/or membrane per roofing manufacturer's requirements.

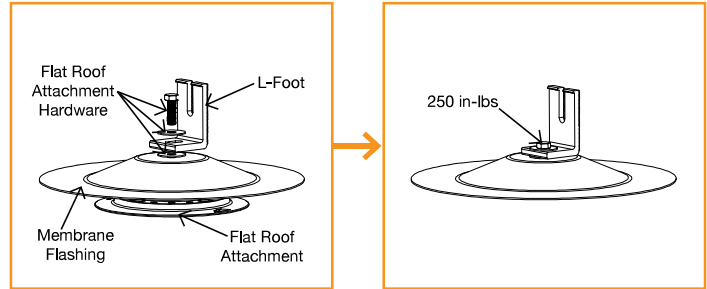

- 💡 **Type, size, and quantity of roof screws to be specified by Structural Engineer. Fastener size not to exceed #15.**
- 💡 **Membrane flashing available for TPO, PVC, and KEE roofs. Ensure membrane flashing is compatible with existing roofing material.**
- 💡 **If membrane flashing is not used, only washer on top of L-Foot is required.**
- 💡 Standalone [Flat Roof Attachment manual](#) available on website.

## END CAPS

End Caps add a completed look and keep debris and pests from collecting inside rail.

Firmly press End Cap onto rail end.

- 💡 **End Caps come in sets of left and right. Check that the proper amount of each has been provided.**

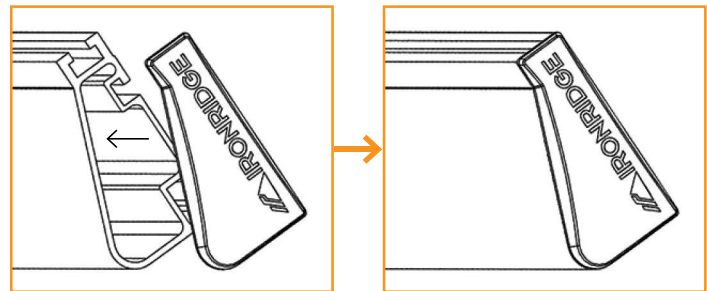

## WIRE CLIPS

Wire Clips offer a simple wire management solution.

Firmly press Wire Clip into top rail slot. Run electrical wire through open clip. Snap closed once all wires have been placed.

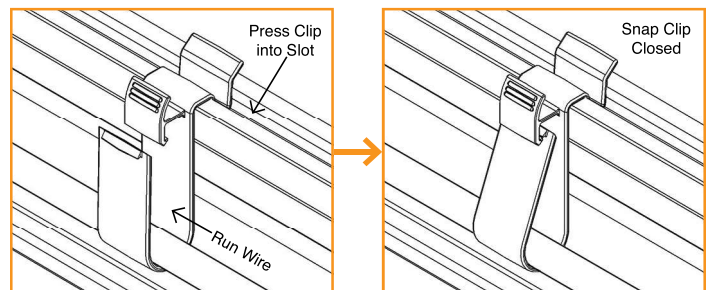

## FLUSH STANDOFFS

Attach Standoffs to roof locations with lag bolts (not included). Place flashing over Standoff. Attach L-Foot on Standoff washer with hardware. Torque to **132 in-lbs (11 ft-lbs)**.



## MICROINVERTER KITS

Use IronRidge's Microinverter Kit to bond compatible microinverters and power optimizers to the racking system.

Insert Microinverter Kit T-bolt into top rail slot. Place compatible microinverter or power optimizer into position and tighten hex nut to **80 in-lbs**.

💡 If installing in areas with ground snow loads greater than 40 psf, install MLPE devices directly next to module frame edge.

### COMPATIBLE PRODUCTS

#### Enphase

M250-72, 250-60, M215-60, C250-72, S230, S280, IQ 6, IQ 6+, IQ 7, IQ 7+, IQ 7X, Q Aggregator

#### Darfon

MIG240, MIG300, G320, G640

#### Solar Edge

P300, P320, P340, P370, P400, P405, P505, P600, P700, P730, P800p, P800s, P850, P860

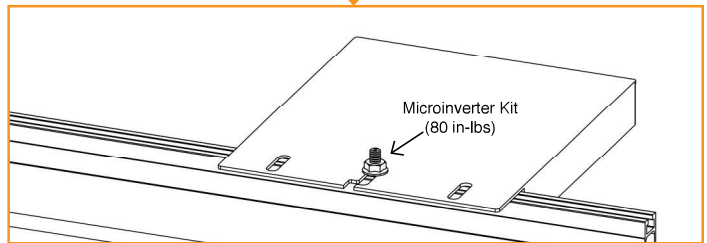
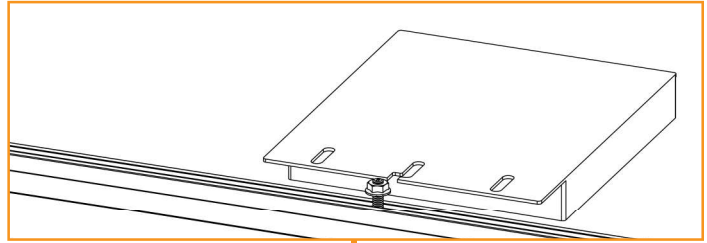

## SYSTEMS USING ENPHASE MICROINVERTERS OR SUNPOWER AC MODULES

IronRidge systems using approved Enphase products or SunPower modules eliminate the need for lay-in lugs and field installed equipment grounding conductors (EGC). This solution meets the requirements of UL 2703 for bonding and grounding and is included in this listing.

The following Sunpower modules are included in this listing: Modules with model identifier Ab-xxx-YY and InvisiMount (G5) 46mm frame; where "A" is either E, or X; "b" can be 17, 18, 19, 20, 21, or 22; and "YY" can be C-AC, D-AC, BLK-C-AC, or BLK-D-AC.

The following Enphase products are included in this listing: Microinverters M250-72, M250-60, M215-60, C250-72, and Engage cables ETXX-240, ETXX-208, ETXX-277.

💡 A minimum of two inverters mounted to the same rail and connected to the same Engage cable are required.

💡 The microinverters or Sunpower AC modules must be used with a maximum 20 A branch rated overcurrent protection device (OCPD).

💡 If an AC module is removed from a circuit for maintenance, you must first disconnect AC power and then install a temporary EGC to bridge the gap by inserting an AC extension cable (or via other NEC-compliant means), in order to maintain effective ground continuity to subsequent modules.

## SYSTEMS USING PHAZR MICROSTORAGE PRODUCTS

Bonding and grounding is achieved via the IronRidge system when using the Microinverter Kit. Running a separate equipment grounding conductor to the PHAZRs is not required.

💡 If installing in areas with ground snow loads greater than 40 psf and underneath a module, install PHAZR devices as close as possible to module frame edge.

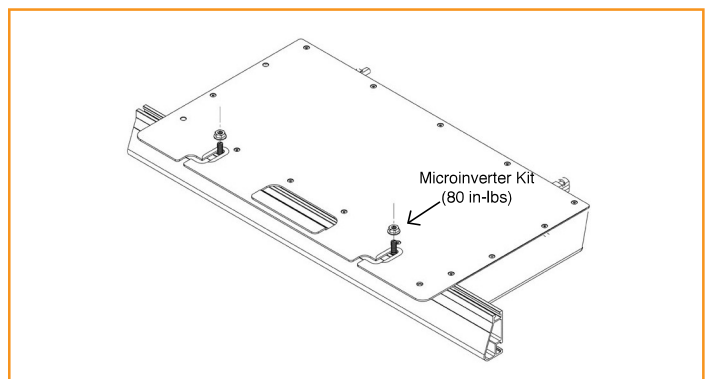

## FRAMELESS MODULE KITS

Insert Frameless Kit T-bolt in top rail slot. Place star washer over T-bolt, allowing it to rest on top of rail. Secure module clamps with a hex nut and torque to **80 in-lbs**.

💡 **Tested or evaluated module clamps:**

- Sunforson silver or black SFS-UTMC-200(B) mid and SFS-UTEC-200(B) end clamps.
- Sunpreme silver or black mid and end clamps with part numbers 7500105X where "X" is 1, 5, 6 or 7.
- IronRidge silver or black mid and end clamps with part numbers FMLS-XC-001-Y where "X" is E or M and "Y" is B or blank.

💡 Follow module manufacturer's installation instructions to install the module clamps.

💡 Frameless modules require using a Grounding Lug on every rail.

💡 For Sunpreme Modules Only: If required to use slide prevention hardware, see Module Slide Prevention Addendum (Version 1.10).

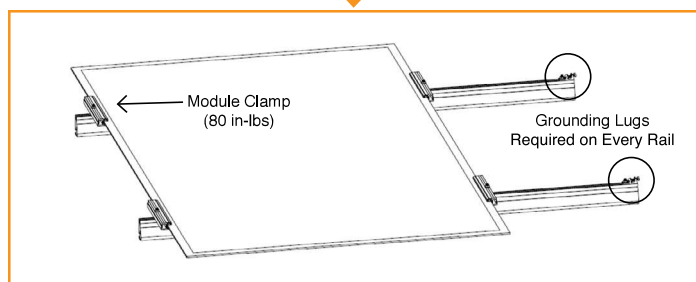
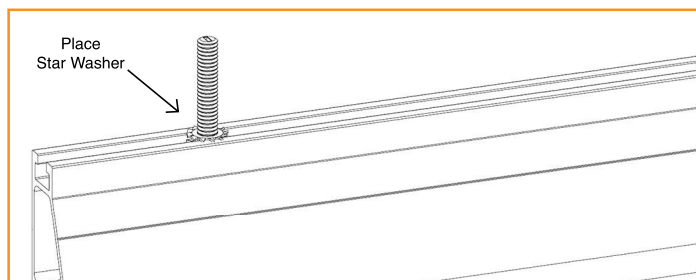

## MODULE COMPATIBILITY

The Flush Mount System may be used to ground and/or mount a PV module complying with UL 1703 only when the specific module has been evaluated for grounding and/or mounting in compliance with the included instructions. Unless otherwise noted, "xxx" refers to the module power rating and both black and silver frames are included in the certification.

MAKE	MODELS
Amerisolar	Modules with 35, 40 and 50mm frames and model identifier ASbYxxxZ; where "b" can be 5 or 6; "Y" can be M, P, M27, P27, M30, or P30; and "Z" can be blank, W or WB.
Astronergy Solar	Modules with 35, 40, and 45mm frames and model identifier aaSM66yyPzz-xxx; where "aa" can be CH or A; "yy" can be either 10 or 12; and "zz" can be blank, HV, (BF) or (BL). Frameless modules with model identifier CHSM6610P(DG)-xxx.
Auxin	Modules with 40mm frames and model identifier AXN6y6zAxxx; where "y" can be M or P; "z" can be 08, 09, 10, 11, or 12; and "A" can be F or T.
Axitec	Modules with 35 and 40mm frames and model identifier AC-xxxY/aa-ZZ; where "Y" can be M or P; "aa" can be 125 or 156; and "ZZ" can be 54S, 60S or 72S.
Boviet	Modules with 40mm frames and model identifier BVM66aaYY-xxx; where "aa" can be 9, 10 or 12; and "YY" is M or P.
BYD	Modules with 35mm frames and model identifier BYDxxxAY-ZZ; where "A" can be M6, P6, or PH; "Y" can be C or K; and "ZZ" can be 30 or 36.
Canadian Solar	Modules with 30, 35 and 40mm frames and model identifier CSbY-xxxZ; where "b" can be 1, 3 or 6; "Y" can be H, K, P, U, V, or X; and "Z" can be M, P, MS, PX, M-SD, P-AG, P-SD, MB-AG, PB-AG, MS-AG, or MS-SD. Frameless modules with model identifier CSbY-xxx-Z; where "b" can be 3 or 6; "Y" is K, P, U, or X; and "Z" can be M-FG, MS-FG, P-FG, MB-FG, or PB-FG.
CertainTeed	Modules with 35 and 40mm frames and model identifier CTxxxYZZ-AA; where "Y" can be M or P; "ZZ" can be 00,01, 10, or 11; and "AA" can be 01, 02 or 03.
CSUN	Modules with 35 and 40mm frames and model identifier YYxxx-zzAbb; where "YY" is CSUN or SST; "zz" is blank, 60, or 72; "A" is blank, P or M; and "bb" is blank, BB, BW, or ROOF.
Ecosolargy	Modules with 35, 40, and 50mm frames and model identifier ECOxxxYzZA-bbD; where "Y" can be A, H, S, or T; "zz" can be 125 or 156; "A" can be M or P; "bb" can be 60 or 72; and "D" can be blank or B.
ET Solar	Modules with 35, 40, or 50mm frames and model identifier ET-Y6ZZxxxAA; where "Y" is P, L, or M; "ZZ" is 60 or 72; and "AA" is WB, WW, BB, WBG, WWG, WBAC, WBCO, WWCO, WWBCO or BBAC.



## MODULE COMPATIBILITY

Flex	Modules with 35, 40, or 50mm frames and model identifier FXS-xxxYY-ZZ; where "xxx" is the module power rating; "YY" is BB or BC; and "ZZ" is MAA1B, MAA1W, MAB1W, SAA1B, SAA1W, SAC1B, SAC1W, SAD1W, SBA1B, SBA1W, SBC1B, or SBC1W.
GCL	Modules with 35 and 40mm frames and model identifier GCL-a6/YY xxx; where "a" can be M or P; and "YY" can be 60, 72, or 72H.
GigaWatt Solar	Modules with 40mm frames and model identifier GWxxxYY; where "YY" is either PB or MB.
Hansol	Modules with 35 and 40mm frames and model identifier HSxxxYY-zz; where "YY" can be TB, TD, UB or UD; and "zz" can be AN1, AN3, AN4.
Hanwha Solar	Modules with 40, 45, or 50mm frames and model identifier HSLaaP6-YY-1-xxxZ; where "aa" is either 60 or 72; "YY" is PA or PB; and "Z" is blank or B.
Hanwha Q CELLS	Modules with 32, 35, 40, and 42mm frames and model identifier aaYY-ZZ-xxx; where "aa" can be Q. or B.; "YY" can be PLUS, PRO, PEAK, LINE PRO, LINE PLUS, or PEAK DUO; and "ZZ" can be G3, G3.1, G4, G4.1, L-G2, L-G2.3, L-G3, L-G3.1, L-G3y, L-G4, L-G4.2, L-G4y, LG4.2/TAA, BFR-G3, BLK-G3, BFR-G3.1, BLK-G3.1, BFR-G4, BFR-G4.1, BFR G4.3, BLK-G4.1, G4/SC, G4.1/SC, G4.1/TAA, G4.1/MAX, BFR G4.1/TAA, BFR G4.1/MAX, BLK G4.1/TAA, BLK G4.1/SC, EC-G4.4, G5, BLK-G5, L-G5, L-G5.1, L-G5.2, L-G5.2/H, L-G5.3, G6, BLK-G6, L-G6, LG6.1, LG6.2, or LG6.3.
Heliene	Modules with 40mm frames and model identifier YYZZxxx; where "YY" is 36, 60, 72, or 96; and "ZZ" is M, P, or MBLK.
Hyundai	Modules with 35, 40 and 50mm frames and model identifier HiS-YxxxZZ; where "Y" can be M or S; and "ZZ" can be KI, MI, MF, MG, SG, RI, RG(BF), RG(BK), TI, or TG.
Itek	Modules with 40 or 50mm frames and model identifier IT-xxx-YY; where "YY" is blank, HE, or SE, or SE72.
JA Solar	Modules with 35, 40 and 45mm frames and model identifier JAyyzz-bb-xxx/aa; where "yy" can be M, P, M6 or P6; "zz" can be blank, (K), (L), (R), (V), (BK), (FA), (TG), (FA)(R), (L)(BK), (L)(TG), (R)(BK), (R)(TG), (V)(BK), (BK)(TG), or (L)(BK)(TG); "bb" can be 48, 60, 72, 60S01, 60S02, 60S03, 72S01, 72S02, 72S03; and "aa" can be MP, SI, SC, PR, PR/1500V, 3BB, 4BB, 4BB/RE, 4BB/1500V, 5BB.
Jinko	Modules with 35 and 40mm frames and model identifier JKMYxxxZZ-aa; where "Y" can either be blank or S; "ZZ" can be P, PP, M; and "aa" can be blank, 60, 60B, 60H, 60L, 60BL, 60HL, 60HBL, 60-J4, 60B-J4, 60B-EP, 60(Plus), 60-V, 60-MX, 72, 72-V, 72H-V, 72L-V, 72HL-V or 72-MX. Frameless modules with model identifier JKMxxxPP-DV.
Kyocera	Modules with 46mm frames and model identifier KYxxxZZ-AA; where "Y" is D or U; "ZZ" is blank, GX, or SX; and "AA" is LPU, LFU, UPU, LPS, LPB, LFB, LFBs, LFB2, LPB2, 3AC, 3BC, 3FC, 4AC, 4BC, 4FC, 4UC, 5AC, 5BC, 5FC, 5UC, 6BC, 6FC, 8BC, 6MCA, or 6MPA.
LG	Modules with 35, 40, and 46mm frames LGxxxYaZ-bb; where "Y" can be A, E, N, Q, S; "a" can be 1 or 2; "Z" can be C, K, T, or W; and "bb" can be A3, A5, B3, G3, G4, K4, or V5.
Longi	Modules with 40 and 45mm frames and model identifier LR6-YYZZ-xxxM; where "YY" can be 60 or 72; and "ZZ" can be BK, BP, HV, PB, PE, or PH.
Mission Solar	Modules with 40mm frames and model identifier MSexxxZZaa; where "ZZ" can be MM, SE, SO or SQ; and "aa" can be 1J, 4J, 4S, 5K, 5T, 6J, 6S, 6W, 8K, 8T, or 9S.
Mitsubishi	Modules with 46mm frames and model identifier PV-MYYxxxZZ; where "YY" is LE or JE; and "ZZ" is either HD, HD2, or FB.
Motech	IM and XS series modules with 40, 45, or 50mm frames.
Neo Solar Power	Modules with 35mm frames and model identifier D6YxxxZZaa; where "Y" can be M or P; "ZZ" can be B3A, B4A, E3A, E4A, H3A, H4A; and "aa" can be blank, (TF), ME or ME (TF).
Panasonic	Modules with 35 and 40mm frames and model identifier VBHNxxxYYzzA; where "YY" can be either SA or KA; "zz" can be either 01, 02, 03, 04, 06, 06B, 11, 11B, 15, 15B, 16, 16B, 17, or 18; and "A" can be blank, E or G.
Peimar	Modules with 40mm frames and model identifier SGxxxYzz; where "Y" can be M or P; and "zz" can be blank, (BF), or (FB).
Phono Solar	Modules with 35, 40, or 45mm frames and model identifier PSxxxY-ZZ/A; where "Y" is M or P; "ZZ" is 20 or 24; and "A" is F, T or U.



## MODULE COMPATIBILITY

Prism Solar	Frameless modules with model identifier BiYY-xxxBSTC; where "YY" can be 48, 60, 60S, 72 or 72S.
REC Solar	Modules with 30, 38 and 45mm frames and model identifier RECxxxYZZ; where "YY" can be M, NP, PE, TP, TP2, TP2M, TP2SM, or TP2S; and "ZZ" can be blank, Black, BLK, BLK2, SLV, or 72.
Renesola	Modules with 35, 40 or 50mm frames and model identifier JCxxxY-ZZ; where "Y" is F, M or S; and "ZZ" is Ab, Ab-b, Abh, Abh-b, Abv, Abv-b, Bb, Bb-b, Bbh, Bbh-b, Bbv, Bbv-b, Db, or Db-b.
Renogy	Modules with 40 or 50mm frames and model identifier RNG-xxxY; where "Y" is D or P.
S-Energy	Modules with 40mm frames and model identifier SNxxxY-ZZ; where "Y" is M or P; and "ZZ" is 10, or 15.
Seraphim Energy Group	Modules with 40mm frames and model identifier SEG-6YY-xxxZZ; where "YY" can be MA, MB, PA, PB; and "ZZ" can be BB, WB, or WW.
Seraphim USA	Modules with 40 and 50mm frames and model identifier SRP-xxx-6YY; where "YY" can be MA, MB, PA, PB, QA-XX-XX, and QB-XX-XX.
Sharp	Modules with 35 or 40mm frames and model identifier NUYYxxx; where "YY" is SA or SC.
Silfab	Modules with 38mm frames and model identifier SYY-Z-xxx; where "YY" is SA or LA; SG or LG; and "Z" is M, P, or X.
Solaria	Modules with 40mm frames and model identifier PowerXT xxxY-ZZ; where "Y" can be R or C; and "ZZ" can be AC, BD, BX, BY, PD, PX, PZ, WX or WZ.
SolarTech	Modules with 42mm frames and model identifier STU-xxxYY; where "YY" can be PERC or HJT.
SolarWorld AG / Industries GmbH	SolarWorld Sunmodule Plus, Protect, Bisun, XL, Bisun XL, may be followed by mono, poly, duo, black, bk, or clear; modules with 31, 33 or 46mm frames and model identifier SW-xxx.
SolarWorld Americas Inc.	SolarWorld Sunmodule Plus, Protect, Bisun, XL, Bisun XL, may be followed by mono, poly, duo, black, bk, or clear; modules with 33mm frames and model identifier SWA-xxx.
Stion	Thin film modules with 35mm frames and model identifier STO-xxx or STO-xxxA. Thin film frameless modules with model identifier STL-xxx or STL-xxxA.
SunEdison	Modules with 35, 40, or 50mm frames and model identifier SE-YxxxZABCDE; where "Y" is B, F, H, P, R, or Z; "Z" is 0 or 4; "A" is B, C, D, E, H, I, J, K, L, M, or N; "B" is B or W; "C" is A or C; "D" is 3, 7, 8, or 9; and "E" is 0, 1 or 2.
Suniva	Modules with 35, 38, 40, 46, or 50mm frames and model identifiers OPTxxx-AA-B-YYY-Z or MVXxxx-AA-B-YYY-Z; where "AA" is either 60 or 72; "B" is either 4 or 5; "YYY" is either 100,101,700,1B0, or 1B1; and "Z" is blank or B.
Sunpower	Modules with standard (G3 or G4) or InvisiMount (G5) 40 and 46mm frames with model identifier SPR-Zb-xxx-YY; where "Z" is either A, E, P or X; "b" can be blank, 17, 18, 19, 20, 21, or 22; and "YY" can be blank, NE, BLK, COM, C-AC, D-AC, E-AC, BLK-C-AC, or BLK-D-AC.
Sunpreme	Sunpreme modules with 35 and 40mm frames and model identifier SNPM-AxB-xxxYzz; where "A" can be G or H; "Y" can be blank or T; and "zz" can be blank, 4BB, SM or 4BB SM. Frameless modules with model identifier SNPM-GxB-xxxZZ; where "ZZ" can be blank, 4BB, SM or 4BB SM.
Sunspark	Modules with 40mm frames and model identifier SYY-xxZ; where "YY" can be MX or ST; and "Z" can be P or W.
Suntech	Vd, Vem, Wdb, Wde, and Wd series modules with 35, 40, or 50mm frames.
Talesun	Modules with 35 and 40mm frames and model identifier TP6yyZxxx-A; where "yy" can be 60, 72, H60 or H72; "Z" can be M, or P; and "A" can be blank, B, or T.
Trina	Modules with 35, 40 or 46mm frames and model identifier TSM-xxxYZZ; where "YY" is PA05, PC05, PD05, PA14, PC14, PD14, PE14, or DD05; and "ZZ" is blank, A, A.05, A.08, A.10, A.18, .05, .08, .10, .18, .08D, .18D, 0.82, A.082(II), .002, .00S, 05S, 08S, A(II), A.08(II), A.05(II), A.10(II), or A.18(II). Frameless modules with model identifier TSM-xxxYY; and "YY" is either PEG5, PEG5.07, PEG14, DEG5(II), DEG5.07(II), or DEG14(II).
Winaico	Modules with 35 or 40mm frames and model identifier Wsy-xxxz6; where "y" is either P or T; and "z" is either M or P.
Yingli	Panda, YGE, and YGE-U series modules with 35, 40, or 50 mm frames.