



**CONTRACTOR INFORMATION:**  
 PALMETTO  
 Address: 1505 King St,  
 EXT ST 114  
 Charleston SC 29405

**SITE INFORMATION:**  
 Chris Young  
 397 Cokesbury Park Ln, Fuquay, NC 27526  
 MAX CONTINUOUS AC SYSTEM SIZE: 10 kW AC  
 DC SYSTEM SIZE: 9.92 kW DC  
 Lat, Long: 35.5601366, -78.8810122  
 (31) Hanwha Q.Peak DUO-G5 320 PV MODULES  
 (1) SolarEdge SE10000H-US (240V) INVERTER

DATE: September 18, 2020  
 PAGE: PV01 SHEET NAME: COVER PAGE  
 DRAWN BY: SoloCAD

AERIAL VIEW:

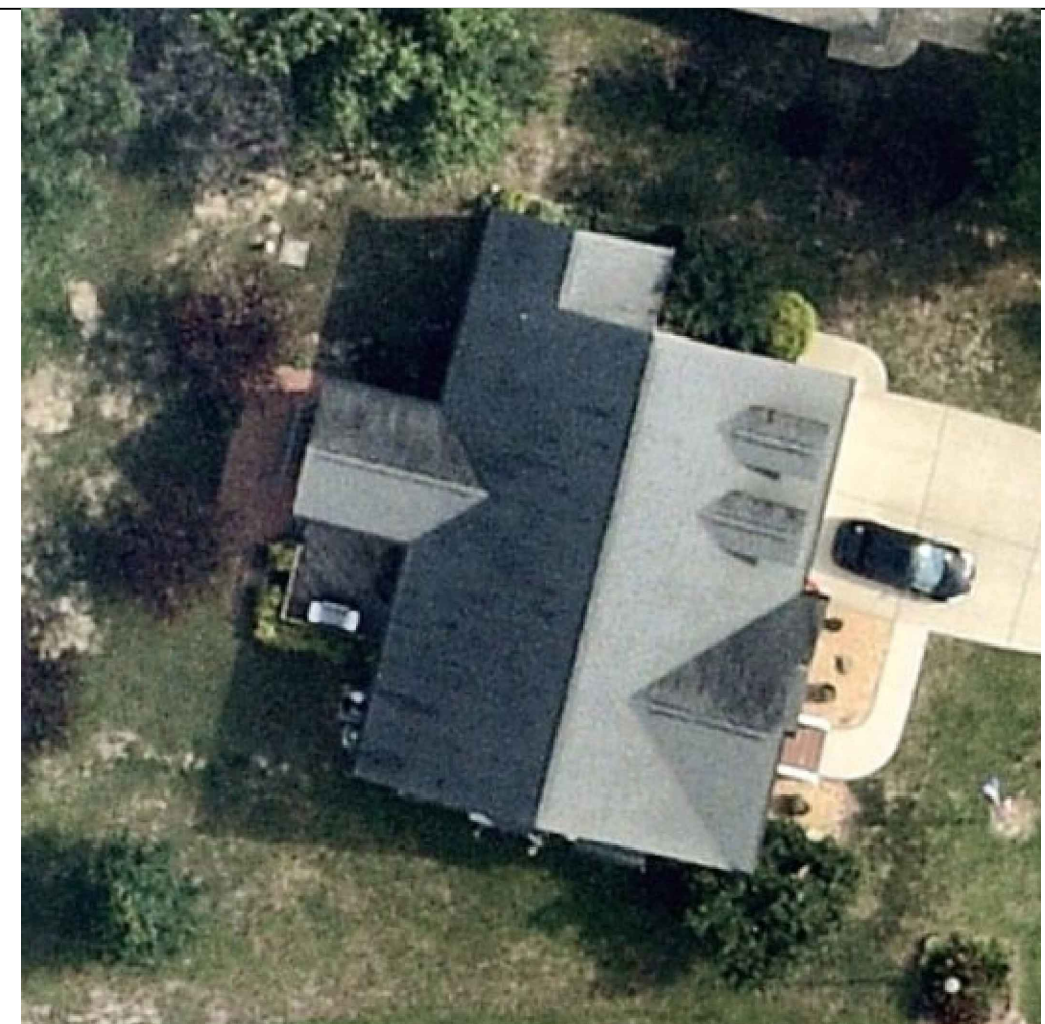

STREET VIEW:

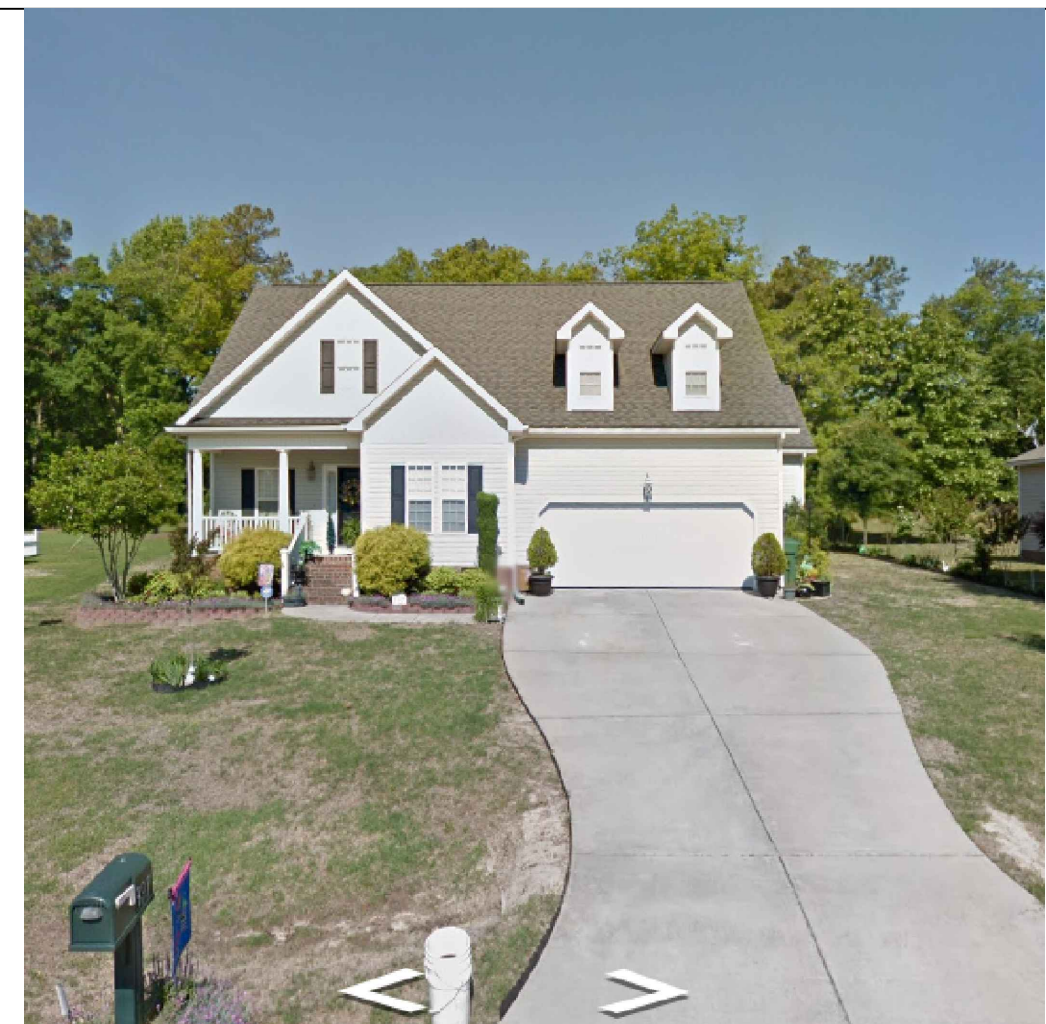

**SHEET INDEX:**

- PV01 COVER PAGE
- PV02 PROPERTY PLAN
- PV03 ROOF PLAN
- PV04 ROOF ATTACHMENTS + BOM
- PV05 MOUNTING DETAIL
- PV06 ELECTRICAL DIAGRAM
- PV07 LABELS
- PV08 PLACARD
- PV09 SITE PHOTOS

**GENERAL NOTES:**

1. INSTALLATION OF SOLAR PHOTOVOLTAIC SYSTEM SHALL BE IN ACCORDANCE WITH NEC ARTICLE 690, AND ALL OTHER APPLICABLE NEC CODES WHERE NOTED OR EXISTING.
2. PROPER ACCESS AND WORKING CLEARANCE AROUND EXISTING AND PROPOSED ELECTRICAL EQUIPMENT WILL COMPLY WITH NEC ARTICLE 110.
3. ALL WIRES, INCLUDING THE GROUNDING ELECTRODE CONDUCTOR SHALL BE PROTECTED FROM PHYSICAL DAMAGE IN ACCORDANCE WITH NEC ARTICLE 250
4. THE PV MODULES ARE CONSIDERED NON-COMBUSTIBLE; THIS SYSTEM IS UTILITY INTERACTIVE PER UL 1741 AND DOES NOT INCLUDE STORAGE BATTERIES OR OTHER ALTERNATIVE STORAGE SOURCES.
5. ALL DC WIRES SHALL BE SIZED ACCORDING TO [NEC 690.8]
6. DC CONDUCTORS SHALL BE WITHIN PROTECTED RACEWAYS IN ACCORDANCE WITH [NEC 690.31]
7. ALL SIGNAGE TO BE PLACED IN ACCORDANCE WITH LOCAL JURISDICTIONAL BUILDING CODE.

**DESCRIPTION OF DESIGN:**

INSTALLATION OF GRID -TIED, UTILITY INTERACTIVE PHOTOVOLTAIC SYSTEM

**EQUIPMENT:**

MAX CONTINUOUS AC SYSTEM SIZE: 10 kW AC  
 DC SYSTEM SIZE: 9.92 kW DC  
 (31) Hanwha Q.Peak DUO-G5 320 PV MODULES  
 (1) SolarEdge SE10000H-US (240V) INVERTER  
 RACKING: FLUSH MOUNT RAILING & ROOF ATTACHMENT SYSTEM - 48" O.C.

**APPLICABLE GOVERNING CODES:**

- 2017 NEC
- 2018 IRC
- 2018 IFC
- 2018 IBC
- 2018 NC RBC

**SITE SPECIFICATIONS:**

OCCUPANCY: R-3  
 ZONING: RESIDENTIAL





**CONTRACTOR INFORMATION:**  
**PALMETTO**  
 Address: 1505 King St,  
 EXT ST 114  
 Charleston SC 29405

**SITE INFORMATION:**  
 Chris Young  
 397 Cokesbury Park Ln, Fuquay, NC 27526  
 MAX CONTINUOUS AC SYSTEM SIZE: 10 KW AC  
 DC SYSTEM SIZE: 9.92 KW DC  
 Lat, Long: 35.5601366, -78.8810122  
 (31) Hanwha Q.Peak DUO-G5 320 PV MODULES  
 (1) SolarEdge SE10000H-US (240V) INVERTER

DATE: September 18, 2020  
 PAGE: PV02 SHEET NAME: PROPERTY PLAN  
 DRAWN BY: SoloCAD SCALE: 1" = 22.81'

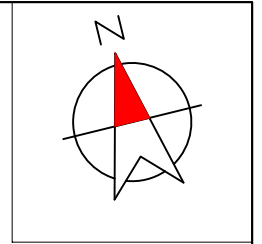

**EQUIPMENT LEGEND:**

- M UTILITY METER
- MSP MAIN SERVICE PANEL
- AC VISIBLE, LOCKABLE, LABELED AC DISCONNECT
- PV METER SOCKET (FOR UTILITY PV METER)
- INV INVERTER
- C COMBINER BOX
- LC LOAD CENTER
- FIRE ACCESS PATHWAY (3' TYP)
- PROPERTY LINE
- BATT BATTERY(IES)

VISIBLE, LOCKABLE, LABELED AC DISCONNECT LOCATED WITHIN 10' OF UTILITY METER

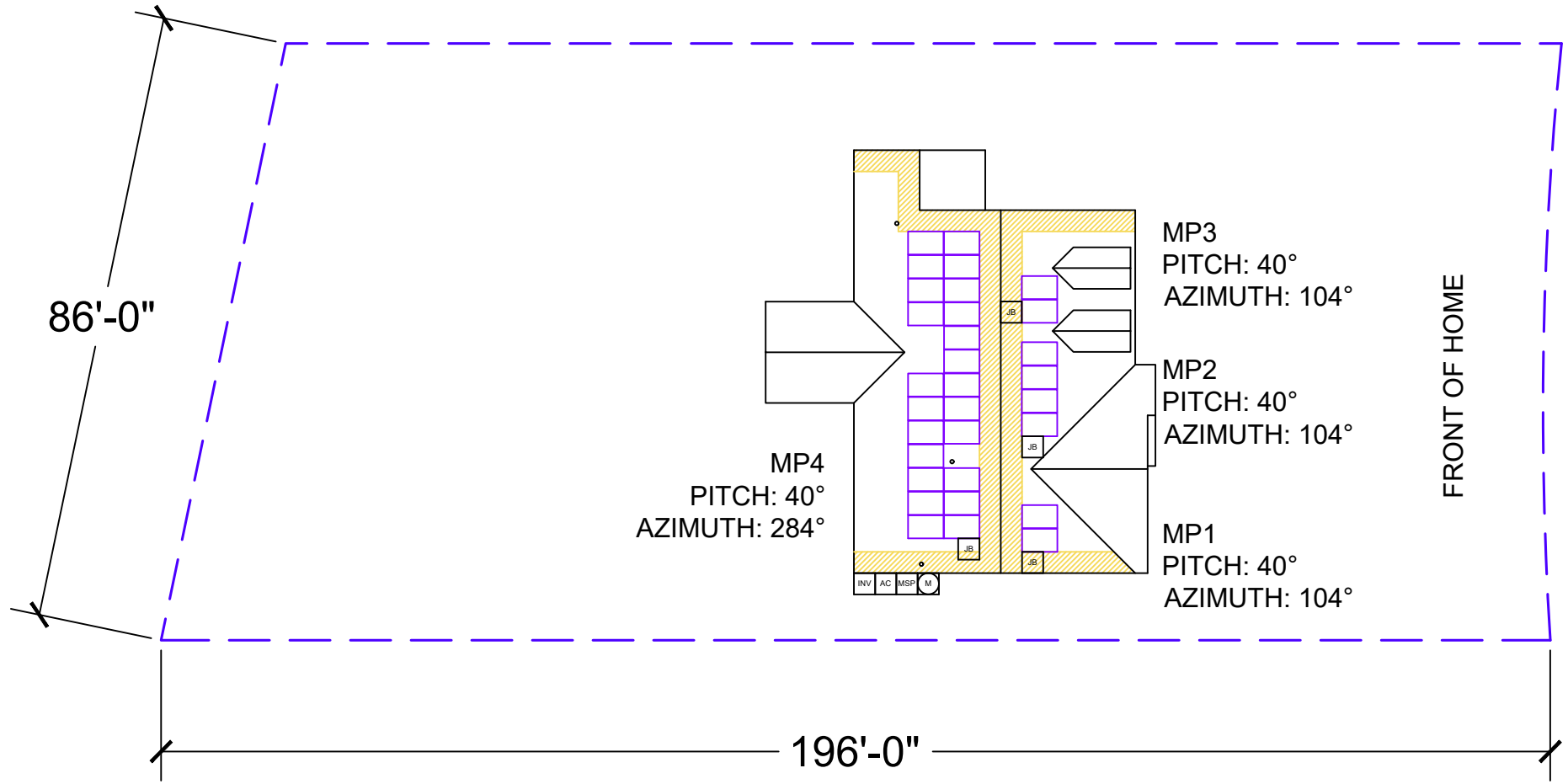



**CONTRACTOR INFORMATION:**  
**PALMETTO**  
 Address: 1505 King St,  
 EXT ST 114  
 Charleston SC 29405

**SITE INFORMATION:**  
 Chris Young  
 397 Cokesbury Park Ln, Fuquay, NC 27526  
 MAX CONTINUOUS AC SYSTEM SIZE: 10 KW AC  
 DC SYSTEM SIZE: 9.92 KW DC  
 Lat, Long: 35.5601366, -78.8810122  
 (31) Hanwha Q.Peak DUO-G5 320 PV MODULES  
 (1) SolarEdge SE10000H-US (240V) INVERTER

DATE: September 18, 2020  
 PAGE: PV03 SHEET NAME: ROOF PLAN  
 DRAWN BY: SoloCAD

**EQUIPMENT LEGEND:**

	UTILITY METER
	MAIN SERVICE PANEL
	VISIBLE, LOCKABLE, LABELED AC DISCONNECT
	METER SOCKET (FOR UTILITY PV METER)
	INVERTER
	COMBINER BOX
	LOAD CENTER
	FIRE ACCESS PATHWAY (3' TYP)
	BATTERY(IES)

VISIBLE, LOCKABLE, LABELED AC DISCONNECT LOCATED WITHIN 10' OF UTILITY METER

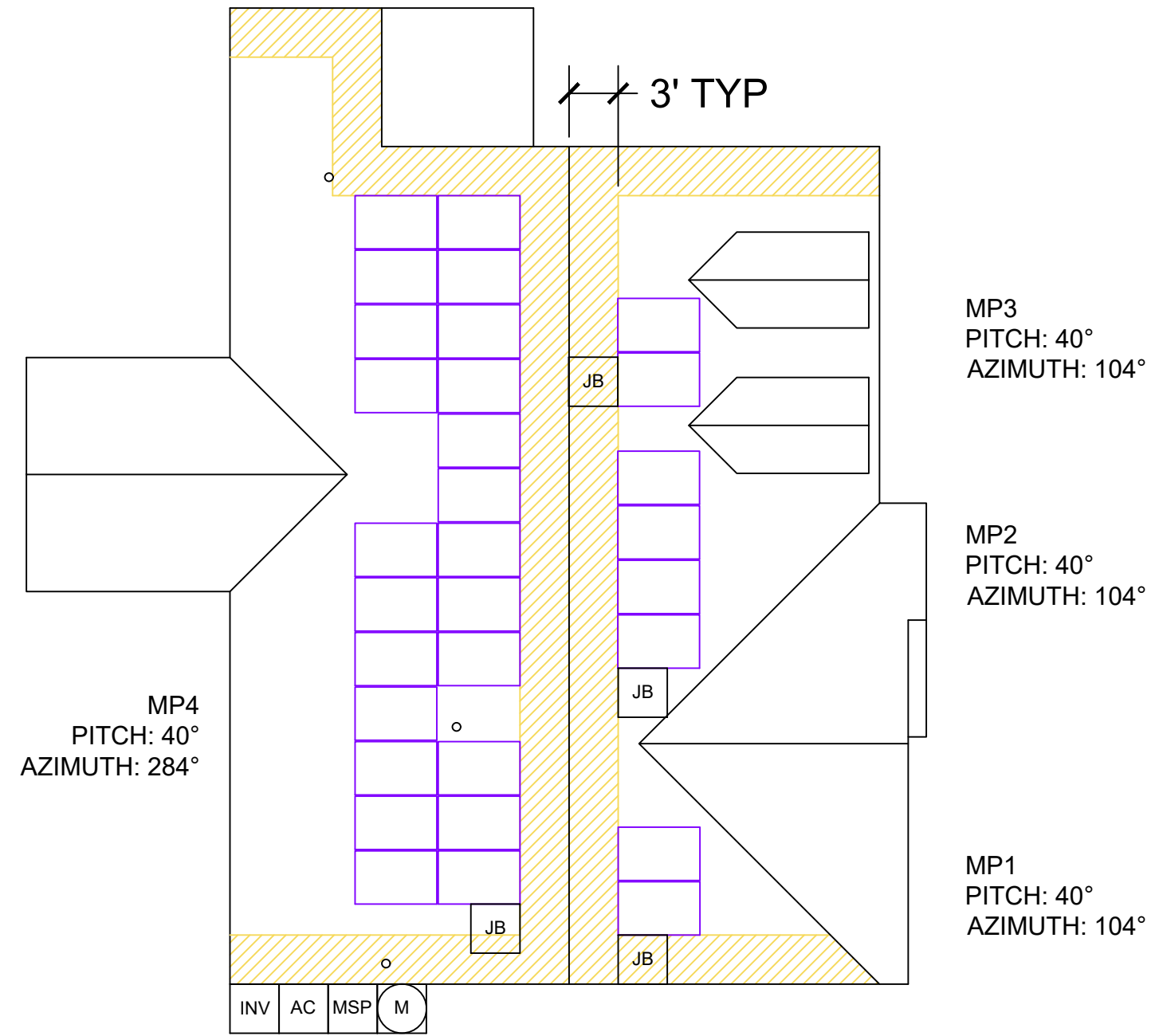
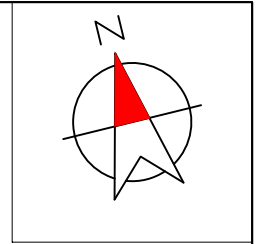



**CONTRACTOR INFORMATION:**  
**PALMETTO**  
 Address: 1505 King St,  
 EXT ST 114  
 Charleston SC 29405

**SITE INFORMATION:**  
 Chris Young  
 397 Cokesbury Park Ln, Fuquay, NC 27526  
 MAX CONTINUOUS AC SYSTEM SIZE: 10 kW AC  
 DC SYSTEM SIZE: 9.92 kW DC  
 Lat, Long: 35.5601366, -78.8810122  
 (31) Hanwha Q.Peak DUO-G5 320 PV MODULES  
 (1) SolarEdge SE10000H-US (240V) INVERTER

DATE: September 18, 2020  
 PAGE: PV04 SHEET NAME: ROOF ATTACHMENTS + BOM  
 DRAWN BY: SoloCAD

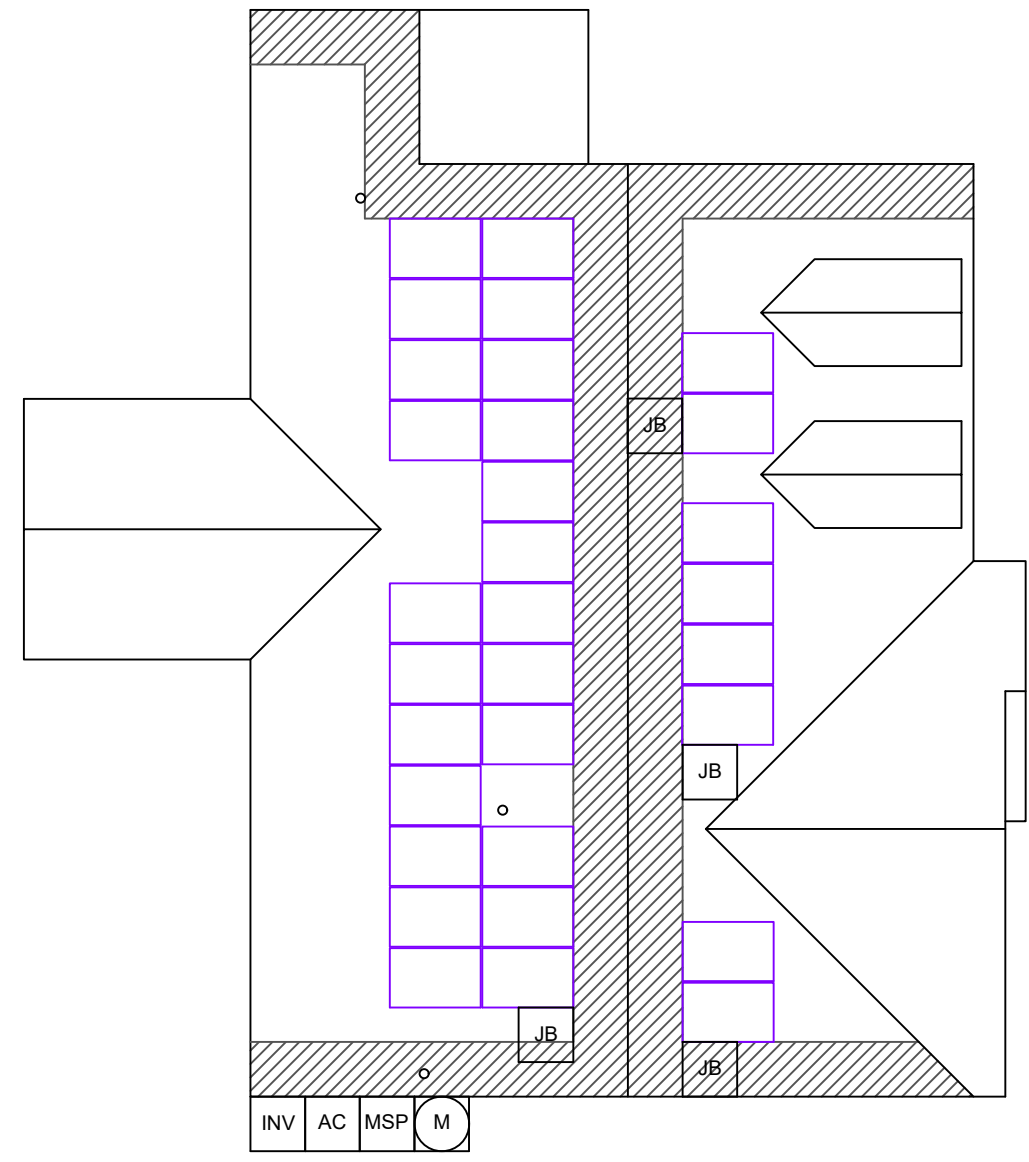
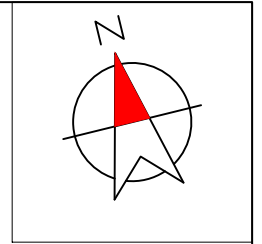

EQUIPMENT INFORMATION:		ROOF INFO:		PHOTOVOLTAIC ARRAY STRUCTURAL CRITERIA:	
RAIL MANUFACTURER	Unirac	ROOF TYPE	asphalt_shingle	ROOF ATTACHMENT COUNT:	64
RAIL PART NUMBER	SM	ROOF FRAMING	traditional_framing	PV MODULE COUNT:	31
ATTACHMENTS	Unirac - FLASHKIT PRO	RAFTER/TOP CHORD SIZE	2x8	ARRAY AREA:	MODULE COUNT * 18.06ft <sup>2</sup> = 559.86
ATTACHMENT QTY	64	RAFTER/TOP CHORD SPACING	16	ROOF AREA:	2593 ft <sup>2</sup>
MIDCLAMP QTY	48	ATTACHMENT SPACING	48	PERCENT OF ROOF COVERED:	22%
ENDCLAMP QTY	28			ARRAY WEIGHT:	MODULE COUNT * 50lbs = 1550
SPLICE QTY	8			DISTRIBUTED LOAD:	ARRAY LBS/ATTACHMENTS = 24.22
				POINT LOAD: (lbs/ft <sup>2</sup> )	(ARRAY) WEIGHT/AREA = 2.77 lbs/ft <sup>2</sup>



**CONTRACTOR INFORMATION:**  
**PALMETTO**  
 Address: 1505 King St,  
 EXT ST 114  
 Charleston SC 29405

**SITE INFORMATION:**  
 Chris Young  
 397 Cokesbury Park Ln, Fuquay, NC 27526  
 MAX CONTINUOUS AC SYSTEM SIZE: 10 KW AC  
 DC SYSTEM SIZE: 9.92 KW DC  
 Lat, Long: 35.5601366, -78.8810122  
 (31) Hanwha Q.Peak DUO-G5 320 PV MODULES  
 (1) SolarEdge SE10000H-US (240V) INVERTER

DATE: September 18, 2020  
 PAGE: PV05 SHEET NAME: MOUNTING DETAIL  
 DRAWN BY: SoloCAD

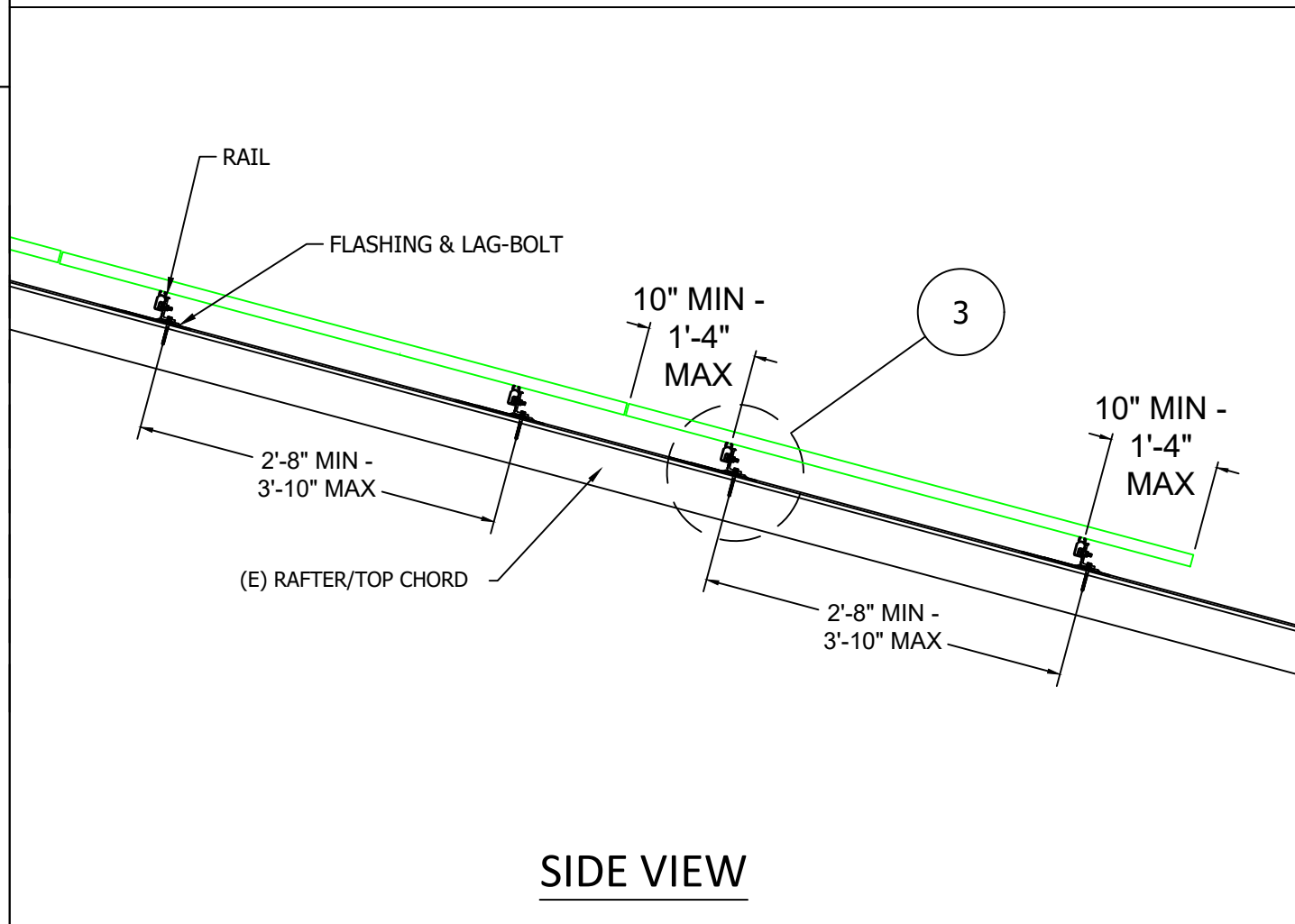
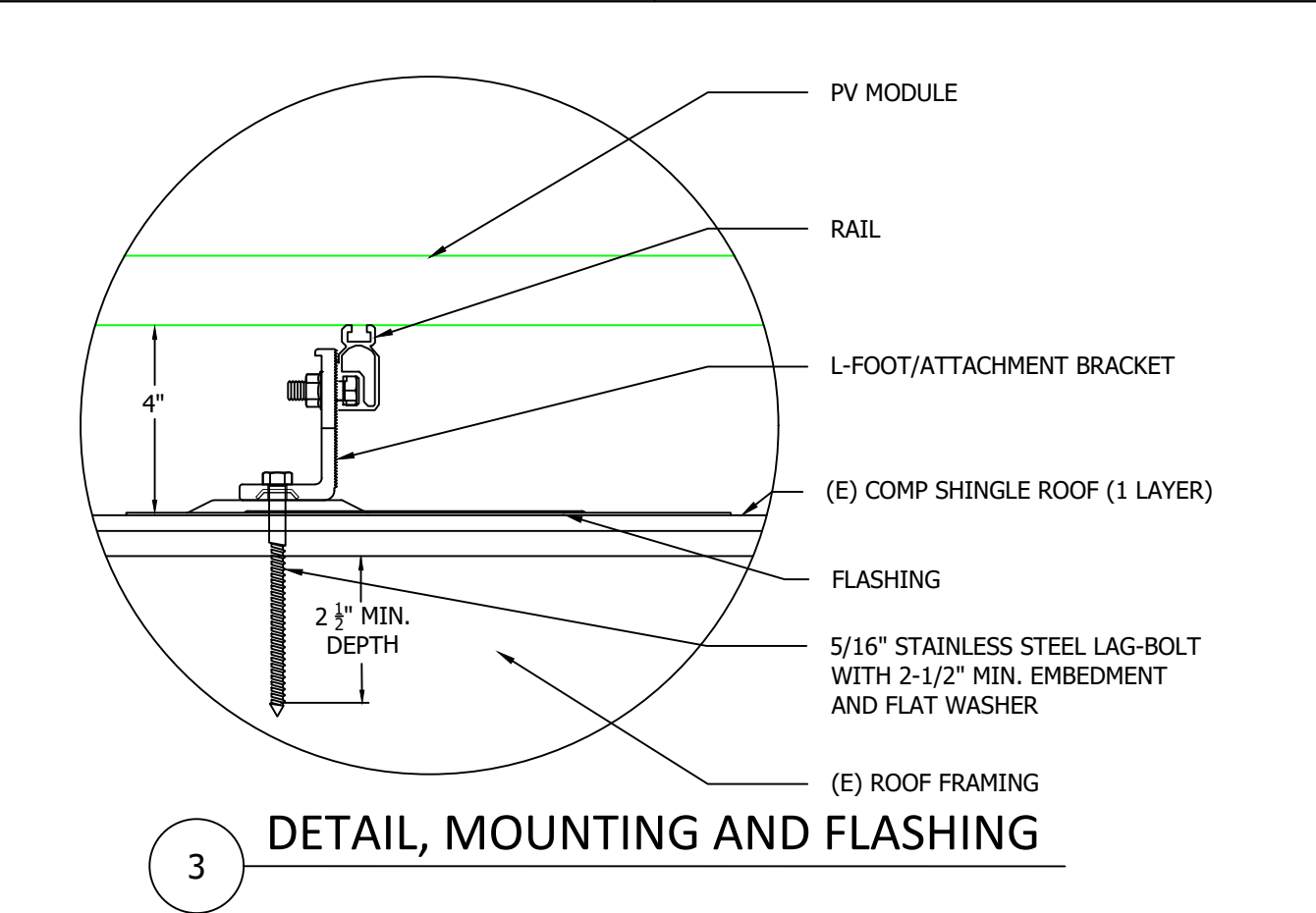
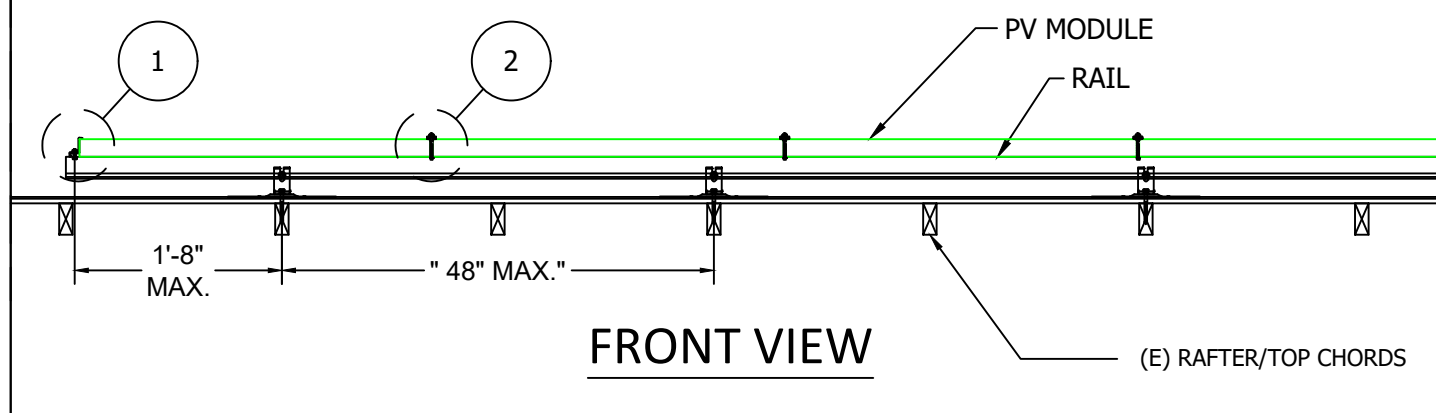
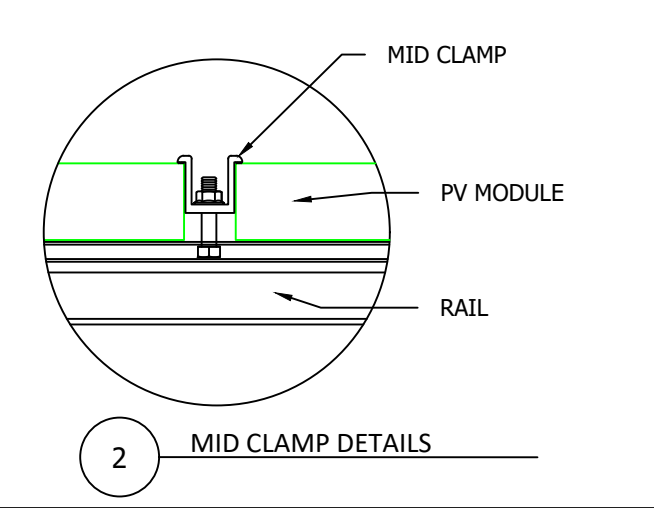
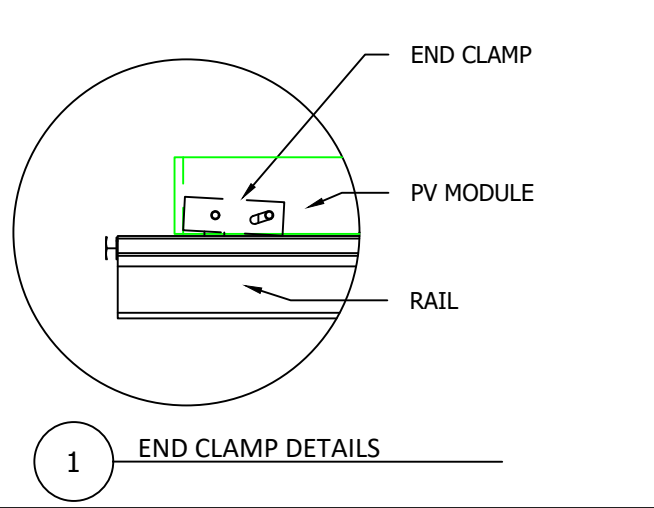

EQUIPMENT INFORMATION:		ROOF INFO:		PHOTOVOLTAIC ARRAY STRUCTURAL CRITERIA:	
RAIL MANUFACTURER	Unirac	ROOF TYPE	asphalt_shingle	ROOF ATTACHMENT COUNT:	64
RAIL PART NUMBER	SM	ROOF FRAMING	traditional_framing	PV MODULE COUNT:	31
ATTACHMENTS	Unirac - FLASHKIT PRO	RAFTER/TOP CHORD SIZE	2x8	ARRAY AREA:	MODULE COUNT * 18.06ft <sup>2</sup> = 559.86
ATTACHMENT QTY	64	RAFTER/TOP CHORD SPACING	16	ROOF AREA:	2593 ft <sup>2</sup>
MIDCLAP QTY	48	ATTACHMENT SPACING	48	PERCENT OF ROOF COVERED:	22%
ENDCLAMP QTY	28			ARRAY WEIGHT:	MODULE COUNT * 50lbs = 1550
SPLICE QTY	8			DISTRIBUTED LOAD:	ARRAY LBS/ATTACHMENTS = 24.22
				POINT LOAD: (lbs/ft <sup>2</sup> )	(ARRAY) WEIGHT/AREA = 2.77 lbs/ft <sup>2</sup>



**CONTRACTOR INFORMATION:**  
**PALMETTO**  
 Address: 1505 King St,  
 EXT ST 114  
 Charleston SC 29405

**SITE INFORMATION:**  
 Chris Young  
 397 Cokesbury Park Ln, Fuquay, NC 27526  
 MAX CONTINUOUS AC SYSTEM SIZE: 10 kW AC  
 DC SYSTEM SIZE: 9.92 kW DC  
 Lat, Long: 35.5601366, -78.8810122  
 (31) Hanwha Q.Peak DUO-G5 320 PV MODULES  
 (1) SolarEdge SE10000H-US (240V) INVERTER

DATE: September 18, 2020  
 PAGE: SHEET NAME:  
**PV06 ELECTRICAL DIAGRAM**  
 DRAWN BY:  
 SoloCAD

### WIRE SCHEDULE

<b>1</b>	(2) PV-WIRE - 10 AWG, USE-2, COPPER (OR CODE APPROVED EQUIVALENT)  (1) 6 AWG BARE, COPPER (GROUND)	<b>2</b>	(1) 10 AWG THWN-2, or THHN, or 10/2 NM-B COPPER - (POSITIVE) (1) 10 AWG THWN-2, or THHN, or 10/2 NM-B COPPER - (NEGATIVE) (1) 10 AWG THWN-2, or THHN, or 10/2 NM-B COPPER - (GROUND) (1) 3/4" LIQUID TIGHT OR EMT OR FMC (OR CODE APPROVED EQUIVALENT)	<b>3</b>	(2) 10 AWG THHN/THWN-2, COPPER - (POSITIVE) (2) 10 AWG THHN/THWN-2 COPPER - (NEGATIVE) (1) 10 AWG THHN/THWN-2 (GROUND) CONDUIT: 3/4" LIQUID TIGHT OR EMT (OR CODE APPROVED EQUIVALENT)	<b>4</b>	(1) 6 AWG THWN-2 COPPER - (L1) (1) 6 AWG THWN-2 COPPER - (L2) (1) 6 AWG THWN-2 COPPER - (NEUTRAL) (1) 10 AWG THWN-2 COPPER - (GROUND) (1) CONDUIT: 3/4" LIQUID TIGHT OR EMT (OR CODE APPROVED EQUIVALENT)
----------	--	----------	---	----------	---	----------	---

STRINGS:		SERVICE EQUIPMENT & PV OCPD RATINGS	
STRING 1	16 PV MODULES	MAIN	200
STRING 2	15 PV MODULES	BUS	200
		PV OCPD	60
		AC VOLTAGE	240V
		AC DISCONNECT RATING	60

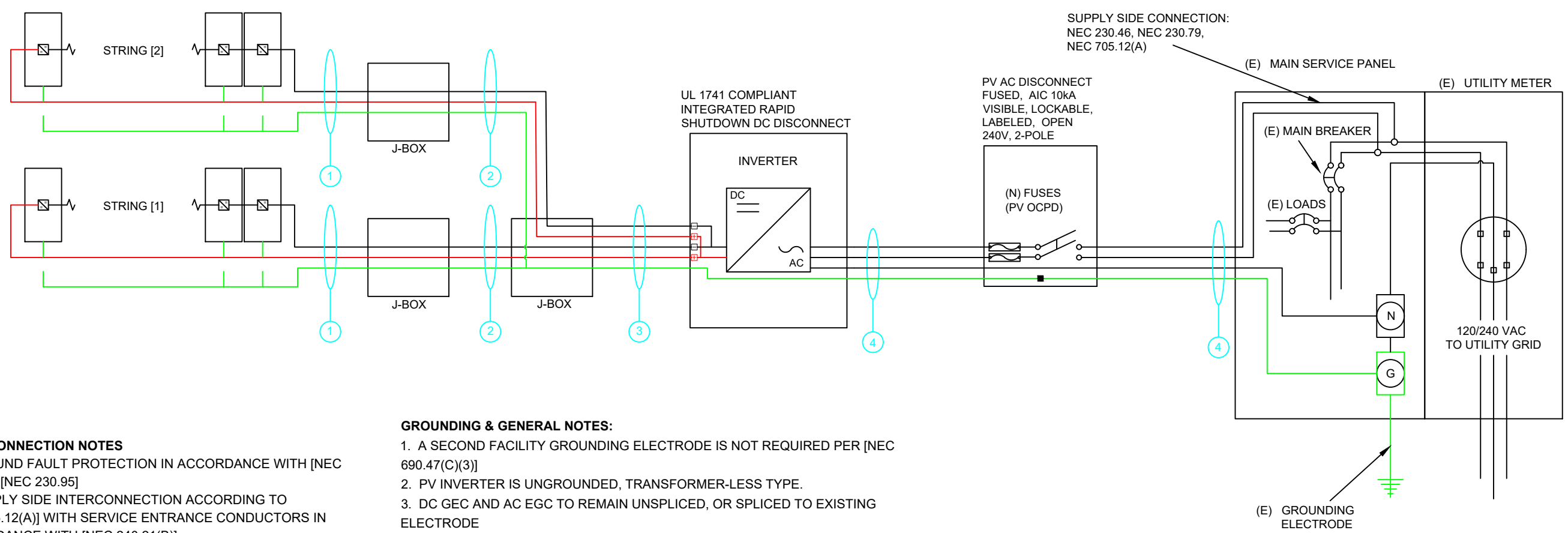

**INTERCONNECTION NOTES**

- GROUND FAULT PROTECTION IN ACCORDANCE WITH [NEC 215.9] & [NEC 230.95]
- SUPPLY SIDE INTERCONNECTION ACCORDING TO [NEC705.12(A)] WITH SERVICE ENTRANCE CONDUCTORS IN ACCORDANCE WITH [NEC 240.21(B)]

**DISCONNECT NOTES**

- DISCONNECTING SWITCHES SHALL BE WIRED SUCH THAT WHEN THE SWITCH IS OPENED THE CONDUCTORS REMAINING LIVE ARE CONNECTED TO THE TERMINALS MARKED "LINE SIDE" (TYPICALLY THE UPPER TERMINALS)
- AC DISCONNECT MUST BE ACCESSIBLE TO QUALIFIED UTILITY PERSONNEL, BE LOCKABLE, AND BE A VISIBLE-BREAK SWITCH.
- FUSED AC DISCONNECT TO BE USED.

**GROUNDING & GENERAL NOTES:**

- A SECOND FACILITY GROUNDING ELECTRODE IS NOT REQUIRED PER [NEC 690.47(C)(3)]
- PV INVERTER IS UNGROUNDED, TRANSFORMER-LESS TYPE.
- DC GEC AND AC EGC TO REMAIN UNSPLICED, OR SPLICED TO EXISTING ELECTRODE
- ANY EXISTING WIRING INVOLVED WITH PV SYSTEM CONNECTION THAT IS FOUND TO BE INADEQUATE PER CODE SHALL BE CORRECTED PRIOR TO FINAL INSPECTION.
- JUNCTION BOX QUANTITIES, AND PLACEMENT SUBJECT TO CHANGE IN THE FIELD - JUNCTION BOXES DEPICTED ON ELECTRICAL DIAGRAM REPRESENT WIRE TYPE TRANSITIONS.
- AC DISCONNECT NOTED IN EQUIPMENT SCHEDULE OPTIONAL IF OTHER AC DISCONNECTING MEANS IS LOCATED WITHIN '10' OF SERVICE DISCONNECT.

EQUIPMENT SCHEDULE:			
TYPE:	QTY:	DESCRIPTION:	RATING:
MODULES:	(31)	Hanwha Q.Peak DUO-G5 320	320 W
INVERTERS:	(1)	SolarEdge SE10000H-US (240V)	10000 W
AC DISCONNECT(S):	(1)	PV AC DISCONNECT, 240V, 2-POLE	60 A
DC OPTIMIZERS:	(31)	SolarEdge P320	15 Adc



**CONTRACTOR INFORMATION:**  
 PALMETTO  
 Address: 1505 King St,  
 EXT ST 114  
 Charleston SC 29405

**SITE INFORMATION:**  
 Chris Young  
 397 Cokesbury Park Ln, Fuquay, NC 27526  
 MAX CONTINUOUS AC SYSTEM SIZE: 10 kW AC  
 DC SYSTEM SIZE: 9.92 kW DC  
 Lat, Long: 35.5601366, -78.8810122  
 (31) Hanwha Q.Peak DUO-G5 320 PV MODULES  
 (1) SolarEdge SE1000H-US (240V) INVERTER

DATE: September 18, 2020  
 PAGE: PV07 SHEET NAME: LABELS  
 DRAWN BY: SoloCAD

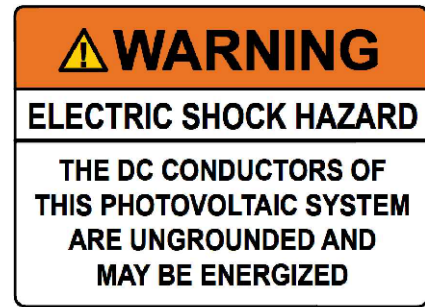

**LABEL 1**  
 AT EACH JUNCTION BOX, COMBINER BOX, DISCONNECT, AND DEVICE WHERE ENERGIZED UNGROUNDED CONDUCTORS MAY BE EXPOSED DURING SERVICE. NEC. 690.35(F)

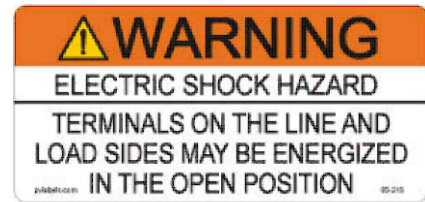

**LABEL 2**  
 FOR PV DISCONNECTING MEANS WHERE ALL TERMINALS OF THE DISCONNECTING MEANS MAY BE ENERGIZED IN THE OPEN POSITION. NEC 690.17(E), NEC 705.22

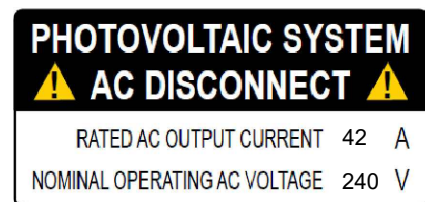

**LABEL 4**  
 AT POINT OF INTERCONNECTION, MARKED AT AC DISCONNECTING MEANS. NEC 690.54, NEC 690.13 (B)

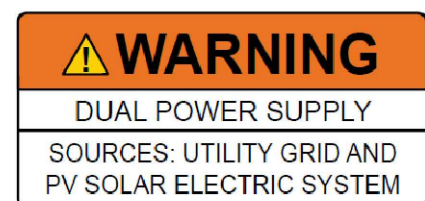

**LABEL 5**  
 AT POINT OF INTERCONNECTION FOR EQUIPMENT CONTAINING OVERCURRENT DEVICES IN CIRCUITS SUPPLYING POWER TO A BUSBAR OR CONDUCTOR SUPPLIED FROM MULTIPLE SOURCES, EACH SERVICE EQUIPMENT AND ALL ELECTRIC POWER PRODUCTION SOURCE LOCATIONS. NEC 705.12(D)(3)



**LABEL 6**  
 AT DIRECT-CURRENT EXPOSED RACEWAYS, CABLE TRAYS, COVERS AND ENCLOSURES OF JUNCTION BOXES, AND OTHER WIRING METHODS; SPACED AT MAXIMUM 10FT SECTION OR WHERE SEPARATED BY ENCLOSURES, WALLS, PARTITIONS, CEILINGS, OR FLOORS. NEC 690.31(G)(3&4)

LABEL VALUES:	
DESCRIPTION	VALUE:
DC IMP:	9.6
DC VMP:	33.32
DC VOC:	40.13
DC ISC:	SEE DATASHEET
DC SYSTEM SIZE (W):	9920
AC OPERATING CURRENT:	SEE DATASHEET
AC VOLTAGE:	240

- LABELING NOTES:**
1. LABELS CALLED OUT ACCORDING TO ALL COMMON CONFIGURATIONS. ELECTRICIAN TO DETERMINE EXACT REQUIREMENTS IN THE FIELD PER CURRENT NEC AND LOCAL CODES AND MAKE APPROPRIATE ADJUSTMENTS.
  2. LABELING REQUIREMENTS BASED ON THE 2017 NATIONAL ELECTRIC CODE, OSHA STANDARD 19010.145, ANSI Z535.
  3. MATERIAL BASED ON THE REQUIREMENTS OF THE AUTHORITY HAVING JURISDICTION.
  4. LABELS TO BE OF SUFFICIENT DURABILITY TO WITHSTAND THE ENVIRONMENT INVOLVED [NEC 110.21]
  5. LABELS TO BE A MINIMUM LETTER HEIGHT OF 3/8", WHITE ON RED BACKGROUND; REFLECTIVE, AND PERMANENTLY AFFIXED [IFC 605.11.1.1]



**LABEL 7**  
 PLACED ADJACENT TO THE BACK-FED BREAKER FROM THE INVERTER IF TIE IN CONSISTS OF LOAD SIDE CONNECTION TO BUSBAR. NEC 705.12(D)(2)(3)(B)

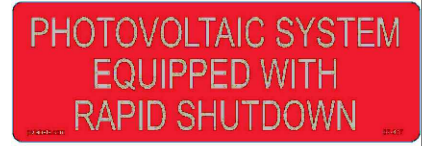

**LABEL 8**  
 SIGN LOCATED AT UTILITY SERVICE EQUIPMENT. NEC 690.56(C)



**LABEL 9 (ONLY IF 3 OR MORE SUPPLY SOURCES TO A BUSBAR)**  
 SIGN LOCATED AT LOAD CENTER IF CONTAINS 3 OR MORE POWER SOURCES. NEC 705.12(D)(2)(3)(C)

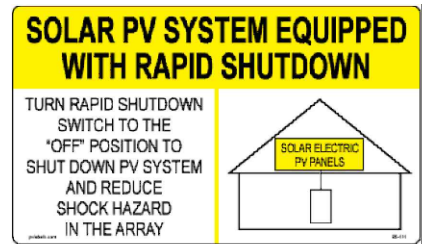

**LABEL 10**  
 FOR PV SYSTEMS THAT SHUT DOWN THE ARRAY AND CONDUCTORS LEAVING THE ARRAY:  
 SIGN TO BE LOCATED ON OR NO MORE THAN 3 FT AWAY FROM SERVICE DISCONNECTING MEANS TO WHICH THE PV SYSTEMS ARE CONNECTED AND SHALL INDICATE THE LOCATION OF ALL IDENTIFIED RAPID SHUTDOWN SWITCHES IF NOT AT THE SAME LOCATION. [NEC 690.56(C)(1)(A)]

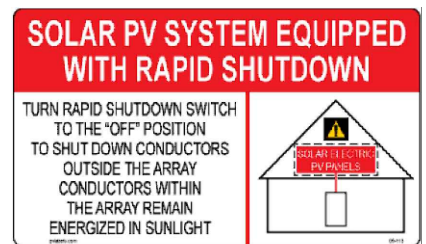

**LABEL 11**  
 FOR PV SYSTEMS THAT ONLY SHUT DOWN CONDUCTORS LEAVING THE ARRAY:  
 SIGN TO BE LOCATED ON OR NO MORE THAN 3 FT AWAY FROM SERVICE DISCONNECTING MEANS TO WHICH THE PV SYSTEMS ARE CONNECTED AND SHALL INDICATE THE LOCATION OF ALL IDENTIFIED RAPID SHUTDOWN SWITCHES IF NOT AT THE SAME LOCATION. [NEC 690.56(C)(1)(B)]

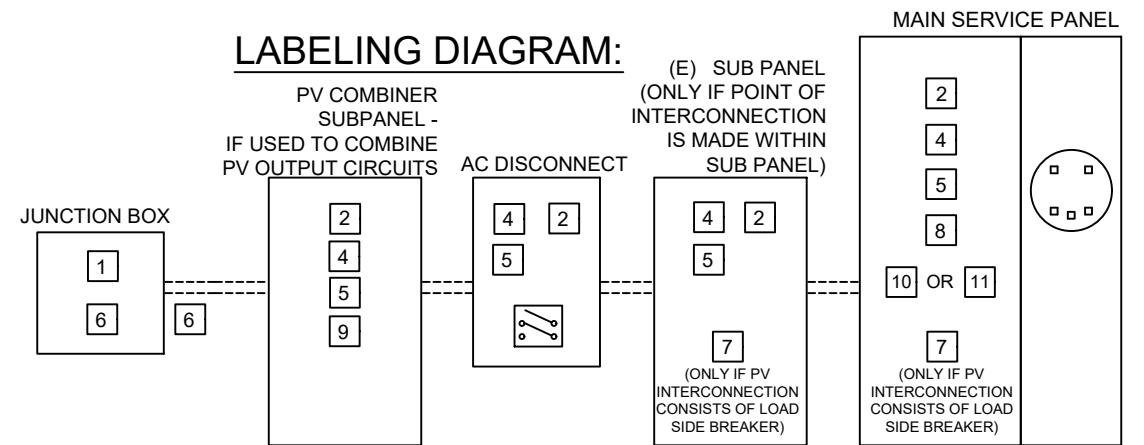

\*\* ELECTRICAL DIAGRAM SHOWN ABOVE IS FOR LABELING PURPOSES ONLY. NOT AN ACTUAL REPRESENTATION OF EQUIPMENT AND CONNECTIONS TO BE INSTALLED. LABEL LOCATIONS PRESENTED MAY VARY DEPENDING ON TYPE OF INTERCONNECTION METHOD AND LOCATION PRESENTED ELECTRICAL DIAGRAM PAGE. \*\*



**CONTRACTOR INFORMATION:**

**PALMETTO**  
Address: 1505 King St,  
EXT ST 114  
Charleston SC 29405

**SITE INFORMATION:**

Chris Young  
397 Cokesbury Park Ln, Fuquay, NC 27526  
MAX CONTINUOUS AC SYSTEM SIZE: 10 kW AC  
DC SYSTEM SIZE: 9.92 kW DC  
Lat, Long: 35.5601366, -78.8810122  
(31) Hanwha Q.Peak DUO-G5 320 PV MODULES  
(1) SolarEdge SE10000H-US (240V) INVERTER

DATE: September 18, 2020

PAGE: PV08 SHEET NAME: PLACARD

DRAWN BY: SoloCAD

# CAUTION

POWER TO THIS BUILDING IS ALSO SUPPLIED FROM ROOF MOUNTED SOLAR ARRAYS WITH SAFETY DISCONNECTS AS SHOWN:

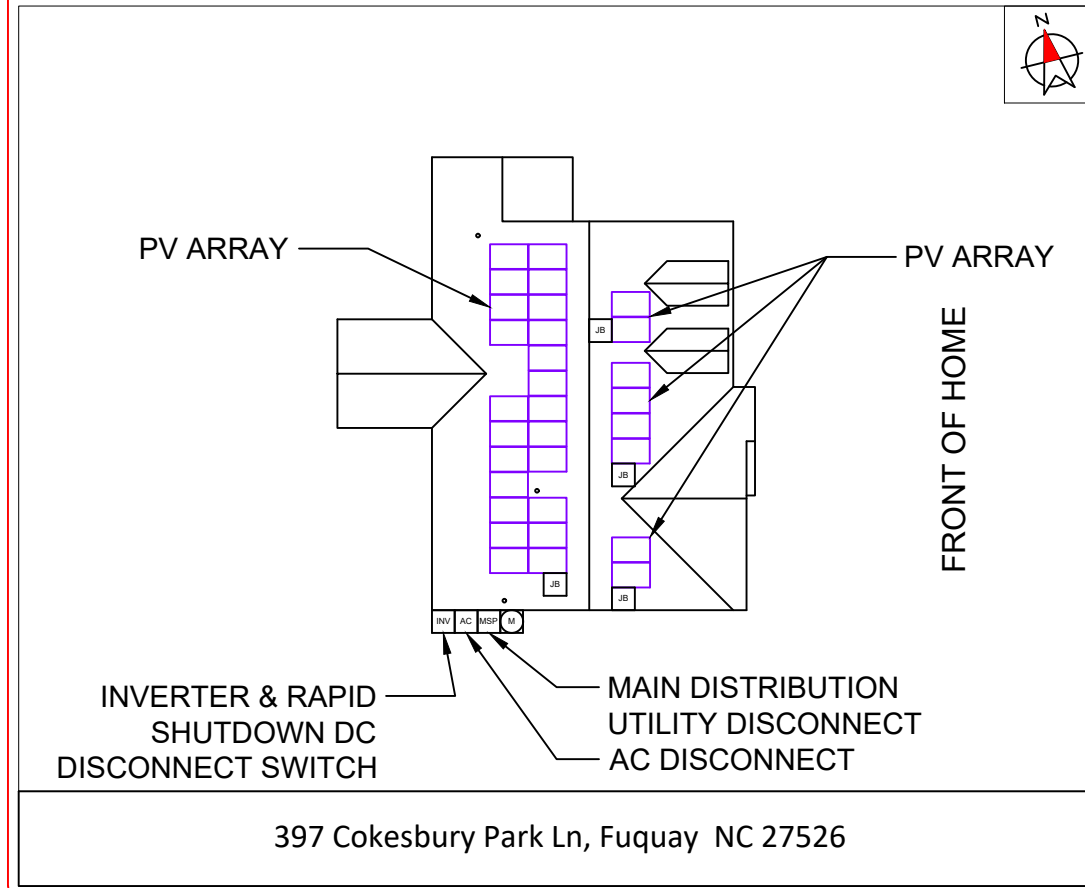

**DIRECTORY**

PERMANENT PLAQUE OR DIRECTORY PROVIDING THE LOCATION OF THE SERVICE DISCONNECTING MEANS AND THE PHOTOVOLTAIC SYSTEM.

(ALL PLAQUES AND SIGNAGE WILL BE INSTALLED AS OUTLINED WITHIN: NEC 690.56(B)&(C), [NEC 705.10])





SITE PHOTOS:

CONTRACTOR INFORMATION:  
PALMETTO  
Address: 1505 King St,  
EXT ST 114  
Charleston SC 29405



SITE INFORMATION:  
Chris Young  
397 Cokesbury Park Ln, Fuquay, NC 27526  
MAX CONTINUOUS AC SYSTEM SIZE: 10 KW AC  
DC SYSTEM SIZE: 9.92 KW DC  
Lat, Long: 35.5601366, -78.8810122  
(31) Hanwha Q.Peak DUO-G5 320 PV MODULES  
(1) SolarEdge SE10000H-US (240V) INVERTER



DATE: September 18, 2020  
PAGE: PV09 SHEET NAME: SITE PHOTOS  
DRAWN BY: SoloCAD



The new Q.PEAK DUO-G5 solar module from Q CELLS impresses thanks to innovative Q.ANTUM DUO Technology, which enables particularly high performance on a small surface. Q.ANTUM's world-record-holding cell concept has now been combined with state-of-the-art circuitry half cells and a six-busbar design, thus achieving outstanding performance under real conditions — both with low-intensity solar radiation as well as on hot, clear summer days.



**Q.ANTUM TECHNOLOGY: LOW LEVELISED COST OF ELECTRICITY**  
Higher yield per surface area, lower BOS costs, higher power classes, and an efficiency rate of up to 19.9%.



**INNOVATIVE ALL-WEATHER TECHNOLOGY**  
Optimal yields, whatever the weather with excellent low-light and temperature behaviour.



**ENDURING HIGH PERFORMANCE**  
Long-term yield security with Anti LID Technology, Anti PID Technology<sup>1</sup>, Hot-Spot Protect and Traceable Quality Tra.Q™.



**EXTREME WEATHER RATING**  
High-tech aluminium alloy frame, certified for high snow (5400 Pa) and wind loads (4000 Pa).



**A RELIABLE INVESTMENT**  
Inclusive 12-year product warranty and 25-year linear performance warranty<sup>2</sup>.



**STATE OF THE ART MODULE TECHNOLOGY**  
Q.ANTUM DUO combines cutting edge cell separation and innovative wiring with Q.ANTUM Technology.

### THE IDEAL SOLUTION FOR:



Rooftop arrays on residential buildings



Rooftop arrays on commercial/industrial buildings



www.VDEInfo.com  
ID: 40032587



<sup>1</sup> APT test conditions according to IEC/TS 62804-1:2015, method B (-1500V, 168 h)  
<sup>2</sup> See data sheet on rear for further information.

### MECHANICAL SPECIFICATION

<b>Format</b>	1685 mm × 1000 mm × 32 mm (including frame)
<b>Weight</b>	18.7 kg
<b>Front Cover</b>	3.2 mm thermally pre-stressed glass with anti-reflection technology
<b>Back Cover</b>	Composite film
<b>Frame</b>	Black anodised aluminium
<b>Cell</b>	6 × 20 monocrystalline Q.ANTUM solar half cells
<b>Junction box</b>	70-85 mm × 50-70 mm × 13-21 mm Protection class IP67, with bypass diodes
<b>Cable</b>	4 mm <sup>2</sup> Solar cable; (+) 1100 mm, (-) 1100 mm
<b>Connector</b>	Multi-Contact, MC4, IP65 and IP68

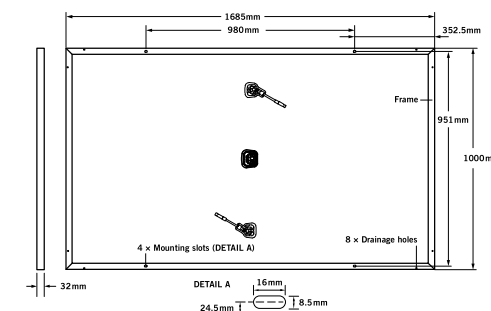

### ELECTRICAL CHARACTERISTICS

POWER CLASS		315	320	325	330	
MINIMUM PERFORMANCE AT STANDARD TEST CONDITIONS, STC <sup>1</sup> (POWER TOLERANCE +5 W / -0 W)						
Minimum	<b>Power at MPP<sup>2</sup></b>	<b>P<sub>MPP</sub></b> [W]	315	320	325	330
	<b>Short Circuit Current*</b>	<b>I<sub>SC</sub></b> [A]	10.04	10.09	10.14	10.20
	<b>Open Circuit Voltage*</b>	<b>V<sub>OC</sub></b> [V]	39.87	40.13	40.40	40.66
	<b>Current at MPP*</b>	<b>I<sub>MPP</sub></b> [A]	9.55	9.60	9.66	9.71
	<b>Voltage at MPP*</b>	<b>V<sub>MPP</sub></b> [V]	32.98	33.32	33.65	33.98
	<b>Efficiency<sup>2</sup></b>	<b>η</b> [%]	≥ 18.7	≥ 19.0	≥ 19.3	≥ 19.6
MINIMUM PERFORMANCE AT NORMAL OPERATING CONDITIONS, NOC <sup>3</sup>						
Minimum	<b>Power at MPP<sup>2</sup></b>	<b>P<sub>MPP</sub></b> [W]	233.4	237.2	240.9	244.6
	<b>Short Circuit Current*</b>	<b>I<sub>SC</sub></b> [A]	8.09	8.14	8.18	8.22
	<b>Open Circuit Voltage*</b>	<b>V<sub>OC</sub></b> [V]	37.30	37.54	37.79	38.04
	<b>Current at MPP*</b>	<b>I<sub>MPP</sub></b> [A]	7.51	7.56	7.60	7.64
	<b>Voltage at MPP*</b>	<b>V<sub>MPP</sub></b> [V]	31.07	31.39	31.70	32.01

<sup>1</sup>1000 W/m<sup>2</sup>, 25 °C, spectrum AM 1.5 G <sup>2</sup>Measurement tolerances STC ±3%; NOC ±5% <sup>3</sup>800 W/m<sup>2</sup>, NOCT, spectrum AM 1.5 G \* typical values, actual values may differ

### Q CELLS PERFORMANCE WARRANTY

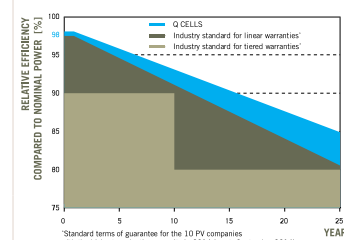

At least 98% of nominal power during first year. Thereafter max. 0.54% degradation per year. At least 93.1% of nominal power up to 10 years. At least 85% of nominal power up to 25 years.

All data within measurement tolerances. Full warranties in accordance with the warranty terms of the Q CELLS sales organisation of your respective country.

### PERFORMANCE AT LOW IRRADIANCE

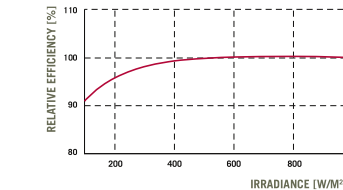

Typical module performance under low irradiance conditions in comparison to STC conditions (25 °C, 1000 W/m<sup>2</sup>).

### TEMPERATURE COEFFICIENTS

<b>Temperature Coefficient of I<sub>SC</sub></b>	<b>α</b> [%/K]	+0.04	<b>Temperature Coefficient of V<sub>OC</sub></b>	<b>β</b> [%/K]	-0.28
<b>Temperature Coefficient of P<sub>MPP</sub></b>	<b>γ</b> [%/K]	-0.37	<b>Normal Operating Cell Temperature</b>	<b>NOCT</b> [°C]	45

### PROPERTIES FOR SYSTEM DESIGN

<b>Maximum System Voltage</b>	<b>V<sub>sys</sub></b> [V]	1000	<b>Safety Class</b>	II
<b>Maximum Reverse Current</b>	<b>I<sub>r</sub></b> [A]	20	<b>Fire Rating</b>	C
<b>Push/Pull Load (Test-load in accordance with IEC 61215)</b>	<b>[Pa]</b>	5400/4000	<b>Permitted Module Temperature On Continuous Duty</b>	-40 °C up to +85 °C

### QUALIFICATIONS AND CERTIFICATES

VDE Quality Tested, IEC 61215 (Ed. 2); IEC 61730 (Ed. 1), Application class A  
This data sheet complies with DIN EN 50380.



**NOTE:** Installation instructions must be followed. See the installation and operating manual or contact our technical service department for further information on approved installation and use of this product.

Hanwha Q CELLS GmbH  
Sonnentallee 17-21, 06766 Bitterfeld-Wolfen, Germany | TEL +49 (0)3494 66 99-23444 | FAX +49 (0)3494 66 99-23000 | EMAIL sales@q-cells.com | WEB www.q-cells.com

Engineered in Germany

**Q CELLS**

Engineered in Germany

**Q CELLS**

# Single Phase Inverter with HD-Wave Technology

for North America

SE3000H-US / SE3800H-US / SE5000H-US / SE6000H-US / SE7600H-US / SE10000H-US / SE11400H-US

12-25  
YEAR  
WARRANTY



INVERTERS

## Optimized installation with HD-Wave technology

- Specifically designed to work with power optimizers
- Record-breaking efficiency
- Fixed voltage inverter for longer strings
- Integrated arc fault protection and rapid shutdown for NEC 2014 and 2017, per article 690.11 and 690.12
- UL1741 SA certified, for CPUC Rule 21 grid compliance
- Extremely small
- Built-in module-level monitoring
- Outdoor and indoor installation
- Optional: Revenue grade data, ANSI C12.20 Class 0.5 (0.5% accuracy)

solaredge.com



## Single Phase Inverter with HD-Wave Technology for North America

SE3000H-US / SE3800H-US / SE5000H-US / SE6000H-US / SE7600H-US / SE10000H-US / SE11400H-US

	SE3000H-US	SE3800H-US	SE5000H-US	SE6000H-US	SE7600H-US	SE10000H-US	SE11400H-US		
<b>OUTPUT</b>									
Rated AC Power Output	3000	3800 @ 240V 3300 @ 208V	5000	6000 @ 240V 5000 @ 208V	7600	10000	11400 @ 240V 10000 @ 208V	VA	
Maximum AC Power Output	3000	3800 @ 240V 3300 @ 208V	5000	6000 @ 240V 5000 @ 208V	7600	10000	11400 @ 240V 10000 @ 208V	VA	
AC Output Voltage Min.-Nom.-Max. (211 - 240 - 264)	✓	✓	✓	✓	✓	✓	✓	Vac	
AC Output Voltage Min.-Nom.-Max. (183 - 208 - 229)	-	✓	-	✓	-	-	✓	Vac	
AC Frequency (Nominal)	59.3 - 60 - 60.5 <sup>1)</sup>							Hz	
Maximum Continuous Output Current @240V	12.5	16	21	25	32	42	47.5	A	
Maximum Continuous Output Current @208V	-	16	-	24	-	-	48.5	A	
GFDI Threshold	1							A	
Utility Monitoring, Islanding Protection, Country Configurable Thresholds	Yes								
<b>INPUT</b>									
Maximum DC Power @240V	4650	5900	7750	9300	11800	15500	17650	W	
Maximum DC Power @208V	-	5100	-	7750	-	-	15500	W	
Transformer-less, Ungrounded	Yes								
Maximum Input Voltage	480							Vdc	
Nominal DC Input Voltage	380				400			Vdc	
Maximum Input Current @240V <sup>2)</sup>	8.5	10.5	13.5	16.5	20	27	30.5	Adc	
Maximum Input Current @208V <sup>2)</sup>	-	9	-	13.5	-	-	27	Adc	
Max. Input Short Circuit Current	45							Adc	
Reverse-Polarity Protection	Yes								
Ground-Fault Isolation Detection	600ka Sensitivity								
Maximum Inverter Efficiency	99	99.2						%	
CEC Weighted Efficiency	99						99 @ 240V 98.5 @ 208V	%	
Nighttime Power Consumption	< 2.5							W	
<b>ADDITIONAL FEATURES</b>									
Supported Communication Interfaces	RS485, Ethernet, ZigBee (optional), Cellular (optional)								
Revenue Grade Data, ANSI C12.20	Optional <sup>3)</sup>								
Rapid Shutdown - NEC 2014 and 2017 690.12	Automatic Rapid Shutdown upon AC Grid Disconnect								
<b>STANDARD COMPLIANCE</b>									
Safety	UL1741, UL1741 SA, UL1699B, CSA C22.2, Canadian AFCI according to T.I.L. M-07								
Grid Connection Standards	IEEE1547, Rule 21, Rule 14 (H)								
Emissions	FCC Part 15 Class B								
<b>INSTALLATION SPECIFICATIONS</b>									
AC Output Conduit Size / AWG Range	1" Maximum / 14-6 AWG				1" Maximum / 14-4 AWG				
DC Input Conduit Size / # of Strings / AWG Range	1" Maximum / 1-2 strings / 14-6 AWG				1" Maximum / 1-3 strings / 14-6 AWG				
Dimensions with Safety Switch (HxWxD)	17.7 x 14.6 x 6.8 / 450 x 370 x 174				21.3 x 14.6 x 7.3 / 540 x 370 x 185				in / mm
Weight with Safety Switch	22 / 10	25.1 / 11.4	26.2 / 11.9	38.8 / 17.6				lb / kg	
Noise	< 25				< 50				dBA
Cooling	Natural Convection								
Operating Temperature Range	-13 to +140 / -25 to +60 <sup>4)</sup> (-40°F / -40°C option) <sup>5)</sup>							°F / °C	
Protection Rating	NEMA 4X (Inverter with Safety Switch)								

<sup>1)</sup> For other regional settings please contact SolarEdge support

<sup>2)</sup> A higher current source may be used; the inverter will limit its input current to the values stated

<sup>3)</sup> Revenue grade inverter P/N: SE000H-US000NNC2

<sup>4)</sup> For power de-rating information refer to: <https://www.solaredge.com/sites/default/files/se-temperature-derating-note-na.pdf>

<sup>5)</sup> -40 version P/N: SE000H-US000NNU4

# Power Optimizer

For North America

P320 / P340 / P370 / P400 / P405 / P505



POWER OPTIMIZER

## PV power optimization at the module-level

- Specifically designed to work with SolarEdge inverters
- Up to 25% more energy
- Superior efficiency (99.5%)
- Mitigates all types of module mismatch losses, from manufacturing tolerance to partial shading
- Flexible system design for maximum space utilization
- Fast installation with a single bolt
- Next generation maintenance with module-level monitoring
- Meets NEC requirements for arc fault protection (AFCI) and Photovoltaic Rapid Shutdown System (PVRSS)
- Module-level voltage shutdown for installer and firefighter safety

solaredge.com



# Power Optimizer For North America

P320 / P340 / P370 / P400 / P405 / P505

Optimizer model (typical module compatibility)	P320 (for 60-cell modules)	P340 (for high-power 60-cell modules)	P370 (for higher-power 60 and 72-cell modules)	P400 (for 72 & 96-cell modules)	P405 (for thin film modules)	P505 (for higher current modules)	
<b>INPUT</b>							
Rated Input DC Power <sup>(1)</sup>	320	340	370	400	405	505	W
Absolute Maximum Input Voltage (Voc at lowest temperature)	48		60	80	125 <sup>(2)</sup>	87 <sup>(2)</sup>	Vdc
MPPT Operating Range	8 - 48		8 - 60	8 - 80	12.5 - 105	12.5 - 87	Vdc
Maximum Short Circuit Current (Isc)	11			10.1		14	Adc
Maximum DC Input Current	13.75			12.5		17.5	Adc
Maximum Efficiency	99.5						%
Weighted Efficiency	98.8					98.6	%
Overvoltage Category	II						
<b>OUTPUT DURING OPERATION (POWER OPTIMIZER CONNECTED TO OPERATING SOLAREEDGE INVERTER)</b>							
Maximum Output Current	15						Adc
Maximum Output Voltage	60			85			Vdc
<b>OUTPUT DURING STANDBY (POWER OPTIMIZER DISCONNECTED FROM SOLAREEDGE INVERTER OR SOLAREEDGE INVERTER OFF)</b>							
Safety Output Voltage per Power Optimizer	1 ± 0.1						Vdc
<b>STANDARD COMPLIANCE</b>							
EMC	FCC Part15 Class B, IEC61000-6-2, IEC61000-6-3						
Safety	IEC62109-1 (class II safety), UL1741						
Material	UL94 V-0, UV Resistant						
RoHS	Yes						
<b>INSTALLATION SPECIFICATIONS</b>							
Maximum Allowed System Voltage	1000						Vdc
Compatible inverters	All SolarEdge Single Phase and Three Phase inverters						
Dimensions (W x L x H)	129 x 153 x 27.5 / 5.1 x 6 x 1.1		129 x 153 x 33.5 / 5.1 x 6 x 1.3	129 x 159 x 49.5 / 5.1 x 6.3 x 1.9	129 x 162 x 59 / 5.1 x 6.4 x 2.3		mm / in
Weight (including cables)	630 / 1.4		750 / 1.7	845 / 1.9	1064 / 2.3		gr / lb
Input Connector	Single or dual MC4 <sup>(3)</sup>						
Input Wire Length	0.16 / 0.52						m / ft
Output Wire Type / Connector	Double Insulated / MC4						
Output Wire Length	0.9 / 2.95		1.2 / 3.9				m / ft
Operating Temperature Range	-40 - +85 / -40 - +185						°C / °F
Protection Rating	IP68 / NEMA6P						
Relative Humidity	0 - 100						%

<sup>(1)</sup> Rated power of the module at STC will not exceed the optimizer "Rated Input DC Power". Modules with up to +5% power tolerance are allowed

<sup>(2)</sup> NEC 2017 requires max input voltage be not more than 80V

<sup>(3)</sup> For other connector types please contact SolarEdge

PV System Design Using a SolarEdge Inverter <sup>(4)(5)</sup>	Single Phase HD-Wave	Single phase	Three Phase 208V	Three Phase 480V	
Minimum String Length (Power Optimizers)	P320, P340, P370, P400 P405 / P505	8	10	18	
Maximum String Length (Power Optimizers)		6	13 (12 with SE3K)	14	
Maximum String Length (Power Optimizers)		25	25	50 <sup>(6)</sup>	
Maximum Power per String	5700 (6000 with SE7600-US - SE11400-US)	5250	6000 <sup>(7)</sup>	12750 <sup>(8)</sup>	W
Parallel Strings of Different Lengths or Orientations	Yes				

<sup>(4)</sup> For detailed string sizing information refer to: [http://www.solaredge.com/sites/default/files/string\\_sizing\\_na.pdf](http://www.solaredge.com/sites/default/files/string_sizing_na.pdf)

<sup>(5)</sup> It is not allowed to mix P405/P505 with P320/P340/P370/P400 in one string

<sup>(6)</sup> A string with more than 30 optimizers does not meet NEC rapid shutdown requirements; safety voltage will be above the 30V requirement

<sup>(7)</sup> For SE14.4KUS/SE43.2KUS: It is allowed to install up to 6,500W per string when 3 strings are connected to the inverter (3 strings per unit for SE43.2KUS) and when the maximum power difference between the strings is up to 1,000W

<sup>(8)</sup> For SE30KUS/SE33.3KUS/SE66.6KUS/SE100KUS: It is allowed to install up to 15,000W per string when 3 strings are connected to the inverter (3 strings per unit for SE66.6KUS/SE100KUS) and when the maximum power difference between the strings is up to 2,000W

© SolarEdge Technologies Ltd. All rights reserved. SOLAREEDGE, the SolarEdge logo, OPTIMIZED BY SOLAREEDGE are trademarks or registered trademarks of SolarEdge Technologies, Inc. All other trademarks mentioned herein are trademarks of their respective owners. Date: 07/2019/V01/ENG NAM. Subject to change without notice.

CE RoHS

# SOLARMOUNT



**SOLARMOUNT** is the professionals' choice for residential PV mounting applications. Every aspect of the system is designed for an easier, faster installation experience. SOLARMOUNT is a complete solution with revolutionary universal clamps, FLASHKIT PRO, full system UL 2703 certification and 25-year warranty. Not only is SOLARMOUNT easy to install, but best-in-class aesthetics make it the most attractive on any block!

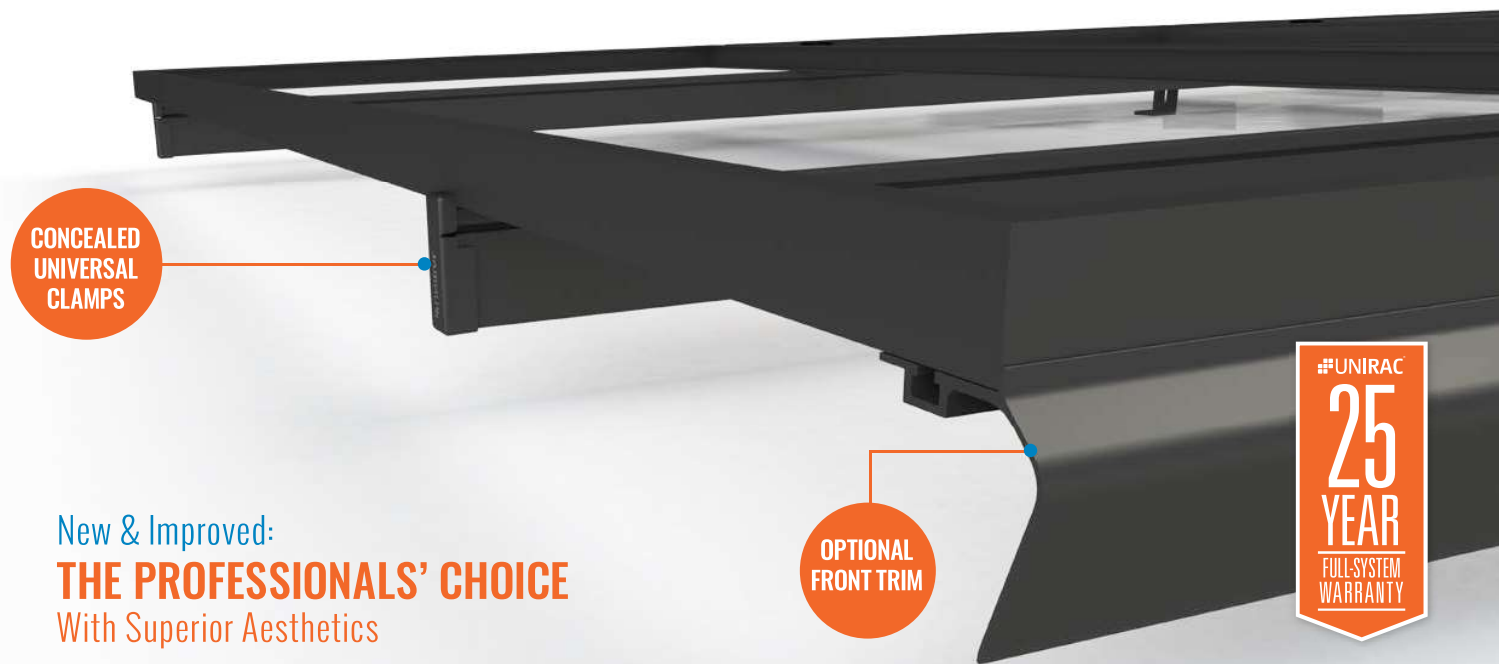

New & Improved:  
**THE PROFESSIONALS' CHOICE**  
With Superior Aesthetics



**NOW FEATURING FLASHKIT PRO**  
The Complete Roof Attachment Solution  
FEATURING **EcoFasten Solar** TECHNOLOGY



**NOW WITH UNIVERSAL MIDCLAMPS**  
Accommodates 30mm-51mm module frames  
One tool, one-person installs are here!



**REVOLUTIONARY NEW ENDCLAMPS**  
Concealed design and included End Caps

## THE PROFESSIONALS' CHOICE FOR RESIDENTIAL RACKING

BEST INSTALLATION EXPERIENCE • CURB APPEAL • COMPLETE SOLUTION • UNIRAC SUPPORT

# SOLARMOUNT



## BETTER DESIGNS

### TRUST THE INDUSTRY'S BEST DESIGN TOOL

Start the design process for every project in our U-Builder on-line design tool. It's a great way to save time and money.

## BETTER SYSTEMS

### ONE SYSTEM - MANY APPLICATIONS

Quickly set modules flush to the roof on steep pitched roofs. Orient a large variety of modules in Portrait or Landscape. Tilt the system up on flat or low slow roofs. Components available in mill, clear, and dark finishes to optimize your design financials and aesthetics.

## BETTER RESULTS

### MAXIMIZE PROFITABILITY ON EVERY JOB

Trust Unirac to help you minimize both system and labor costs from the time the job is quoted to the time your teams get off the roof. Faster installs. Less Waste. More Profits.

## BETTER SUPPORT

### WORK WITH THE INDUSTRIES MOST EXPERIENCED TEAM

Professional support for professional installers and designers. You have access to our technical support and training groups. Whatever your support needs, we've got you covered. Visit [Unirac.com/solarmount](http://Unirac.com/solarmount) for more information.



### CONCEALED UNIVERSAL ENDCLAMPS

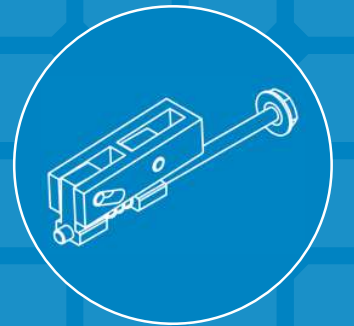

### END CAPS INCLUDED WITH EVERY ENDCLAMP

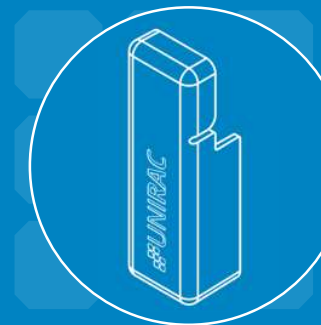

### UNIVERSAL SELF-STANDING MIDCLAMPS

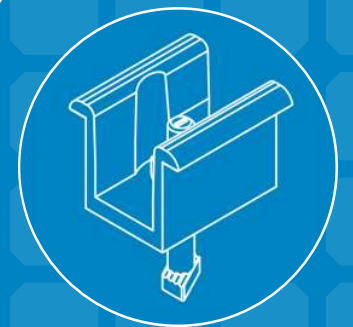

### U-BUILDER ONLINE DESIGN TOOL SAVES TIME & MONEY

Visit [design.unirac.com](http://design.unirac.com)

## UNIRAC CUSTOMER SERVICE MEANS THE HIGHEST LEVEL OF PRODUCT SUPPORT

UNMATCHED EXPERIENCE	CERTIFIED QUALITY	ENGINEERING EXCELLENCE	BANKABLE WARRANTY	DESIGN TOOLS	PERMIT DOCUMENTATION
----------------------	-------------------	------------------------	-------------------	--------------	----------------------

### TECHNICAL SUPPORT

Unirac's technical support team is dedicated to answering questions & addressing issues in real time. An online library of documents including engineering reports, stamped letters and technical data sheets greatly simplifies your permitting and project planning process.

### CERTIFIED QUALITY PROVIDER

Unirac is the only PV mounting vendor with ISO certifications for 9001:2008, 14001:2004 and OHSAS 18001:2007, which means we deliver the highest standards for fit, form, and function. These certifications demonstrate our excellence and commitment to first class business practices.

### BANKABLE WARRANTY

Don't leave your project to chance, Unirac has the financial strength to back our products and reduce your risk. Have peace of mind knowing you are providing products of exceptional quality. SOLARMOUNT is covered by a 25 year limited product warranty and a 5 year limited finish warranty.

ENHANCE YOUR REPUTATION WITH QUALITY RACKING SOLUTIONS BACKED BY ENGINEERING EXCELLENCE AND A SUPERIOR SUPPLY CHAIN

PUB2016MAY16 - PRINTED UPDATE

# FLASHKIT PRO



FLASHKIT PRO is the complete attachment solution for composition shingle roofs. Featuring Unirac's patented SHED & SEAL technology, a weather proof system which provides the ultimate protection against roof leaks. Kitted in 10 packs for maximum convenience, flashings and hardware are available in Mill or Dark finishes. With FLASHKIT pro, you have everything you need for a quick, professional installation.



**TRUSTED WATER SEAL FLASHINGS**  
FEATURING SHED & SEAL TECHNOLOGY



**YOUR COMPLETE SOLUTION**  
Flashings, lags, continuous slot L-Feet and hardware



**CONVENIENT 10 PACKS**  
Packaged for speed and ease of handling

# FLASHKIT PRO

## INSTALLATION GUIDE



FLASHKIT PRO IS THE COMPLETE FLASHING AND ATTACHMENT SOLUTION FOR COMPOSITION ROOFS.



**STEP 1**  
INSTALL FLASHKIT PRO FLASHING



**STEP 2**  
INSTALL L-FOOT



**STEP 3**  
ATTACH L-FOOT TO RAIL

### PRE-INSTALL

- Locate roof rafters and snap chalk lines to mark the installation point for each roof attachment.
- Drill a 7/32" pilot hole at each roof attachment. Fill each pilot hole with sealant.

### STEP 1 INSTALL FLASHKIT PRO FLASHING

- Add a U-shaped bead of roof sealant to the underside of the flashing with the open side of the U pointing down the roof slope. Slide the aluminum flashing underneath the row of shingles directly up slope from the pilot hole as shown. Align the indicator marks on the lower end of the flashing with the chalk lines on the roof to center the raised hole in the flashing over the pilot hole in the roof. When installed correctly, the flashing will extend under the two courses of shingles above the pilot hole.

### STEP 2 INSTALL L-FOOT

- Fasten L-foot and Flashing into place by passing the included lag bolt and pre-installed stainless steel-backed EPDM washer through the L-foot EPDM grommet, and the raised hole in the flashing, into the pilot hole in the roof rafter.

- Drive the lag bolt down until the L-foot is held firmly in place. It is normal for the EPDM on the underside of the stainless steel backed EPDM washer to compress and expand beyond the outside edge of the steel washer when the proper torque is applied.

#### TIP:

- Use caution to avoid over-torquing the lag bolt if using an impact driver.
- Repeat Steps 1 and 2 at each roof attachment point.

### STEP 3 ATTACH L-FOOT TO RAIL

- Insert the included 3/8" -16 T-bolts into the lower slot on the Rail (sold separately), spacing the bolts to match the spacing between the roof attachments.
- Position the Rail against the L-Foot and insert the threaded end of the T-Bolt through the continuous slot in the L-Foot. Apply anti-seize to bolt threads to prevent galling of the T-bolt and included 3/8" serrated flange nut. Place the 3/8" flange nut on the T-bolt and finger tighten. Repeat STEP 3 until all L-Feet are secured to the Rail with a T-bolt. Adjust the level and height of the Rail and torque each bolt to 30ft-lbs.

## THE COMPLETE ROOF ATTACHMENT SOLUTION

FOR QUESTIONS OR CUSTOMER SERVICE VISIT UNIRAC.COM OR CALL (505) 248-2702

## FASTER INSTALLATION. 25-YEAR WARRANTY.

FOR QUESTIONS OR CUSTOMER SERVICE VISIT UNIRAC.COM OR CALL (505) 248-2702