

November 27, 2020

PowerHome Solar
 919 N. Main St
 Mooresville, NC 28115

RE: Bennett Residence
538 Tripp Road, Lillington, NC 27546
Client Project #: 538BENN
PFE Project #: 205183

On behalf of PowerHome Solar, Penn Fusion Engineering LLC (PFE) performed a site visit and structural analysis of the roof design at the above referenced location. The purpose of our analysis was to determine if the existing design of the roof system is structurally sufficient to support the new photovoltaic modules in addition to the code required design loads. Information used for this analysis was determined by a site survey performed by a representative of PFE and is isolated only to the areas where the modules are intended to be placed. If any discrepancies are found by the contractor during installation, please contact PFE.

System Specifications:

 Panel Specs: (26) Hanwha – Q Cells
 Racking System: Quick Mount PV – QRail Light

The modules are to be located on the following roof planes:

Mounting Plane	Rafter Size	Rafter Spacing	Horizontal Span	Collar Ties	Collar Tie Spacing	Sheathing	Shingle Type	Number of Shingle Layers	Ceiling Profile
1	2x8	16"	10ft. 4in.	N/A	0"	CDX 1/2"	Asphalt Shingles	1	Flat
2	2x6	24"	7ft. 5in.	N/A	0"	CDX 1/2"	Asphalt Shingles	1	Flat
3	2x4	24"	11ft. 6in.	N/A	0"	CDX 1/2"	Asphalt Shingles	1	Flat

The roof design has been analyzed in accordance with the 2018 North Carolina Residential/Building Code with design loads as follows:

 Ground Snow (Pg): 15 psf
 Wind Speed (V): 120 mph

Mounting Plane 1

The calculations for these structural members are attached. It has been determined by this office that the roof, as specified above, is adequate to support the new PV modules in addition to the code required design loading.

Attach the module rail brackets to the roof with 5/16" lag bolts at 48 on center maximum with staggered penetration such that load is distributed evenly among roof members. Provide a minimum of 2" of penetration into the wood members.

Mounting Plane 2

The calculations for these structural members are attached. It has been determined by this office that the roof, as specified above, is adequate to support the new PV modules in addition to the code required design loading.

Attach the module rail brackets to the roof with 5/16" lag bolts at 48 on center maximum with staggered penetration such that load is distributed evenly among roof members. Provide a minimum of 2" of penetration into the wood members.

Mounting Plane 3

The calculations for these structural members are attached. It has been determined by this office that the rafters, as specified above, exceed the allowable span for the total design loading. Attached are repair details that, when installed, will render the roof design structurally adequate to support the new PV modules in addition to the code required design loading.

Attach the module rail brackets to the roof with 5/16" lag bolts at 48 on center maximum with staggered penetration such that load is distributed evenly among roof members. Provide a minimum of 2" of penetration into the wood members.

If you have any questions regarding this analysis, please feel free to contact us.

 Best Regards,
Penn Fusion Engineering LLC
 Firm License No. P-1848

 Andrew D. Leone, P.E.
 Principal

Client Name: PowerHome Solar
 PFE Project Number: 205183
 Client Project Number: 538BENN
 Project: Bennett Residence
 Address: 538 Tripp Road
 Lillington, NC 27546
 Description: Mounting Plane 1
 Calculations By: ADL
 Date: November 27, 2020

Roof Construction

2x8 Rafters at 16" on center

A=	10.88 in ²
Ix=	47.63 in ⁴
Sx=	13.14 in ³
Wood Species=	Doug-Fir Larch #2
Fb=	900 psi
Fv=	180 psi
E=	1600000 psi
Roof Slope=	22 °
Rafter Span=	10.35 ft
Ceiling Attached to Rafters?:	No

Design Criteria

Ground Snow (P _g):	15 psf
Design Wind Speed:	120 mph
Live Load:	20 psf
Dead Load:	4.76 psf
PV Modules:	3.24 psf

Wind Calculations

Directionality Factor (K _d):	0.85
Topographic Factor (K _{zt}):	1
Velocity Pressure Exposure Coefficient (K _z):	0.7
Importance Factor (I):	1
Velocity Pressure (q _z):	21.93 psf
Tributary Square Footage on Component:	10.83 ft ²
Component Roof Pressures:	14.76 / -60.52 psf

Snow Load Calculations

Exposure Factor (C _e):	1
Thermal Factor (C _t):	1
Importance Factor (I):	1
Flat Roof Snow Loads (P _f):	10.5 psf
Roof Slope Factor (C _s):	1
Sloped Snow Loads (P _s):	10.5 psf
Unbalanced Snow Load:	15 psf

Member Calculations

Bending

M_d :	500.22 ft*lb		
f_b :	456.8 psi		
Load Duration Factor (C_d):	1.15		
Stability Factor (C_L):	1		
Wet Service Factor (C_M):	1		
Temperature Factor (C_T):	1		
Size Factor (C_F):	1.2		
Flat Use Factor (C_{fu}):	1		
Incising Factor (C_i):	1		
Repetitive Member Factor (C_r):	1.15		
F_b :	900 psi		
F'_b :	1428.3 psi	456.8 <= 1428.3	OK in Bending

Shear

V_d :	193.26 lb		
f_v :	26.66 psi		
Load Duration Factor (C_d):	1.15		
Wet Service Factor (C_M):	1		
Temperature Factor (C_T):	1		
Size Factor (C_F):	1.2		
Flat Use Factor (C_{fu}):	1		
Incising Factor (C_i):	1		
F_v :	180 psi		
F'_v :	207 psi	26.66 <= 207	OK in Shear

Deflection

Live Load Deflection (Δ_L):	0.09 in	L/1373	OK in Live Load Deflection
Total Load Deflection (Δ_T):	0.13 in	L/981	OK in Total Load Deflection

Uplift Calculation

Tributary Square Footage on Component:	10.83 ft ²
Uplift Pressure:	-60.52 psf
Uplift per Lag:	-655.63 lbs
Lag Screw Diameter:	5/16 in
Allowable Withdrawal per Inch:	490.99 lbs/in
Minimal Screw Penetration:	1.34 in

Install 5/16" diameter lag screws @ 48 on center with minimum penetration of 2" into rafter.

Client Name: PowerHome Solar
 PFE Project Number: 205183
 Client Project Number: 538BENN
 Project: Bennett Residence
 Address: 538 Tripp Road
 Lillington, NC 27546
 Description: Mounting Plane 2
 Calculations By: ADL
 Date: November 27, 2020

Roof Construction

2x6 Rafters at 24" on center

A=	8.25 in ²
Ix=	20.8 in ⁴
Sx=	7.56 in ³
Wood Species=	Doug-Fir Larch #2
Fb=	900 psi
Fv=	180 psi
E=	1600000 psi
Roof Slope=	22 °
Rafter Span=	7.42 ft
Ceiling Attached to Rafters?:	No

Design Criteria

Ground Snow (P _g):	15 psf
Design Wind Speed:	120 mph
Live Load:	20 psf
Dead Load:	4.01 psf
PV Modules:	3.24 psf

Wind Calculations

Directionality Factor (K _d):	0.85
Topographic Factor (K _{zt}):	1
Velocity Pressure Exposure Coefficient (K _z):	0.7
Importance Factor (I):	1
Velocity Pressure (q _z):	21.93 psf
Tributary Square Footage on Component:	10.83 ft ²
Component Roof Pressures:	14.76 / -60.52 psf

Snow Load Calculations

Exposure Factor (C _e):	1
Thermal Factor (C _t):	1
Importance Factor (I):	1
Flat Roof Snow Loads (P _f):	10.5 psf
Roof Slope Factor (C _s):	1
Sloped Snow Loads (P _s):	10.5 psf
Unbalanced Snow Load:	15 psf

Member Calculations

Bending

M_d :	374.73 ft*lb		
f_b :	594.61 psi		
Load Duration Factor (C_d):	1.15		
Stability Factor (C_L):	1		
Wet Service Factor (C_M):	1		
Temperature Factor (C_T):	1		
Size Factor (C_F):	1.3		
Flat Use Factor (C_{fu}):	1		
Incising Factor (C_i):	1		
Repetitive Member Factor (C_r):	1.15		
F_b :	900 psi		
F'_b :	1547.33 psi	594.61 <= 1547.33	OK in Bending

Shear

V_d :	202.08 lb		
f_v :	36.74 psi		
Load Duration Factor (C_d):	1.15		
Wet Service Factor (C_M):	1		
Temperature Factor (C_T):	1		
Size Factor (C_F):	1.3		
Flat Use Factor (C_{fu}):	1		
Incising Factor (C_i):	1		
F_v :	180 psi		
F'_v :	207 psi	36.74 <= 207	OK in Shear

Deflection

Live Load Deflection (Δ_L):	0.08 in	L/1087	OK in Live Load Deflection
Total Load Deflection (Δ_T):	0.11 in	L/798	OK in Total Load Deflection

Uplift Calculation

Tributary Square Footage on Component:	10.83 ft ²
Uplift Pressure:	-60.52 psf
Uplift per Lag:	-655.63 lbs
Lag Screw Diameter:	5/16 in
Allowable Withdrawal per Inch:	490.99 lbs/in
Minimal Screw Penetration:	1.34 in

Install 5/16" diameter lag screws @ 48 on center with minimum penetration of 2" into rafter.

Client Name: PowerHome Solar
 PFE Project Number: 205183
 Client Project Number: 538BENN
 Project: Bennett Residence
 Address: 538 Tripp Road
 Lillington, NC 27546
 Description: Mounting Plane 3
 Calculations By: ADL
 Date: November 27, 2020

Roof Construction

2x4 Rafters at 24" on center

A=	5.25 in ²
Ix=	5.36 in ⁴
Sx=	3.06 in ³
Wood Species=	Doug-Fir Larch #2
Fb=	900 psi
Fv=	180 psi
E=	1600000 psi
Roof Slope=	27 °
Rafter Span=	11.51 ft
Ceiling Attached to Rafters?:	No

Design Criteria

Ground Snow (P _g):	15 psf
Design Wind Speed:	120 mph
Live Load:	20 psf
Dead Load:	3.88 psf
PV Modules:	3.37 psf

Wind Calculations

Directionality Factor (K _d):	0.85
Topographic Factor (K _{zt}):	1
Velocity Pressure Exposure Coefficient (K _z):	0.7
Importance Factor (I):	1
Velocity Pressure (q _z):	21.93 psf
Tributary Square Footage on Component:	10.83 ft ²
Component Roof Pressures:	14.76 / -60.52 psf

Snow Load Calculations

Exposure Factor (C _e):	1
Thermal Factor (C _t):	1
Importance Factor (I):	1
Flat Roof Snow Loads (P _f):	10.5 psf
Roof Slope Factor (C _s):	1
Sloped Snow Loads (P _s):	10.5 psf
Unbalanced Snow Load:	15 psf

Member Calculations

Bending

M_d :	902.19 ft*lb		
f_b :	3535.12 psi		
Load Duration Factor (C_d):	1.15		
Stability Factor (C_L):	1		
Wet Service Factor (C_M):	1		
Temperature Factor (C_T):	1		
Size Factor (C_F):	1.5		
Flat Use Factor (C_{fu}):	1		
Incising Factor (C_i):	1		
Repetitive Member Factor (C_r):	1.15		
F_b :	900 psi		
F'_b :	1785.38 psi	3535.12 > 1785.38	No Good in Bending

Shear

V_d :	313.56 lb		
f_v :	89.59 psi		
Load Duration Factor (C_d):	1.15		
Wet Service Factor (C_M):	1		
Temperature Factor (C_T):	1		
Size Factor (C_F):	1.5		
Flat Use Factor (C_{fu}):	1		
Incising Factor (C_i):	1		
F_v :	180 psi		
F'_v :	207 psi	89.59 <= 207	OK in Shear

Deflection

Live Load Deflection (Δ_L):	1.84 in	L/75	No Good in Live Load Deflection
Total Load Deflection (Δ_T):	2.51 in	L/55	No Good in Total Load Deflection

Uplift Calculation

Tributary Square Footage on Component:	10.83 ft ²
Uplift Pressure:	-60.52 psf
Uplift per Lag:	-655.63 lbs
Lag Screw Diameter:	5/16 in
Allowable Withdrawal per Inch:	490.99 lbs/in
Minimal Screw Penetration:	1.34 in

Install 5/16" diameter lag screws @ 48 on center with minimum penetration of 2" into rafter.

Client Name: PowerHome Solar
PFE Project Number: 205183
Client Project Number: 538BENN
Project: Bennett Residence
Address: 538 Tripp Road
Lillington, NC 27546
Description: Mounting Plane 3
Calculations By: ADL
Date: November 27, 2020

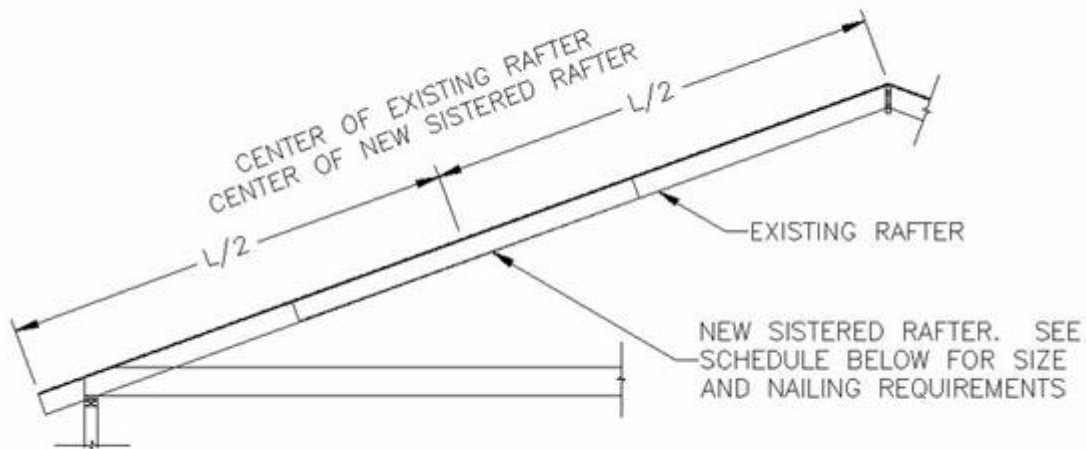

New Sistered Rafter Size: 2x4x8' Doug-Fir Larch #2 or better*

Nailing Requirements: (2) 10d Nails @ 12" on center with (3) additional 10d Nails at each end

10d = .12" shank diameter x 3" long minimum

Note: Apply repair to each rafter under PV system

*Suitable Alternate Species:

- Spruce-Pine-Fir #2 or #1
- Southern-Yellow-Pine #2 or #1