

MAP VIEW

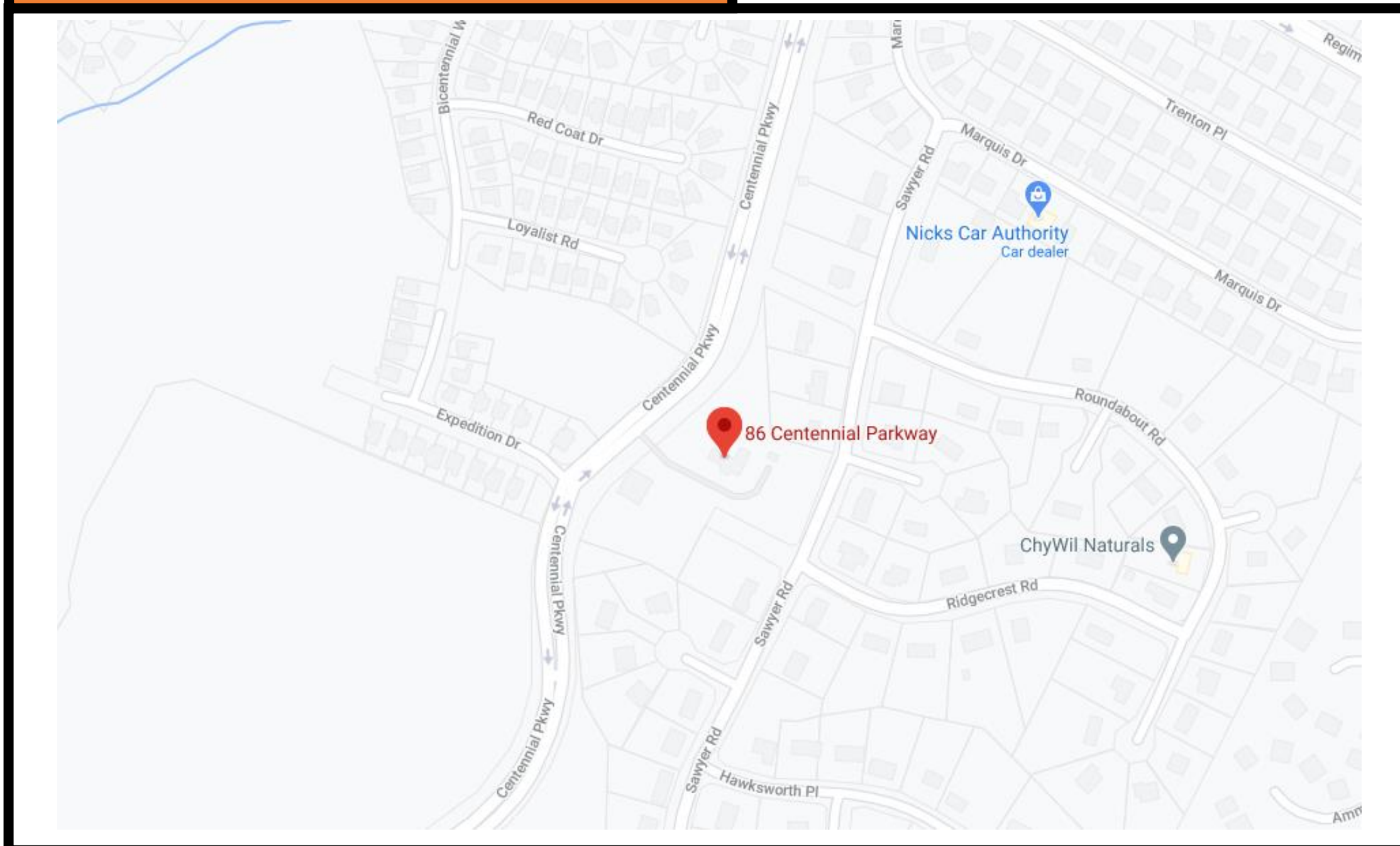

AERIAL VIEW



PLAN VIEW

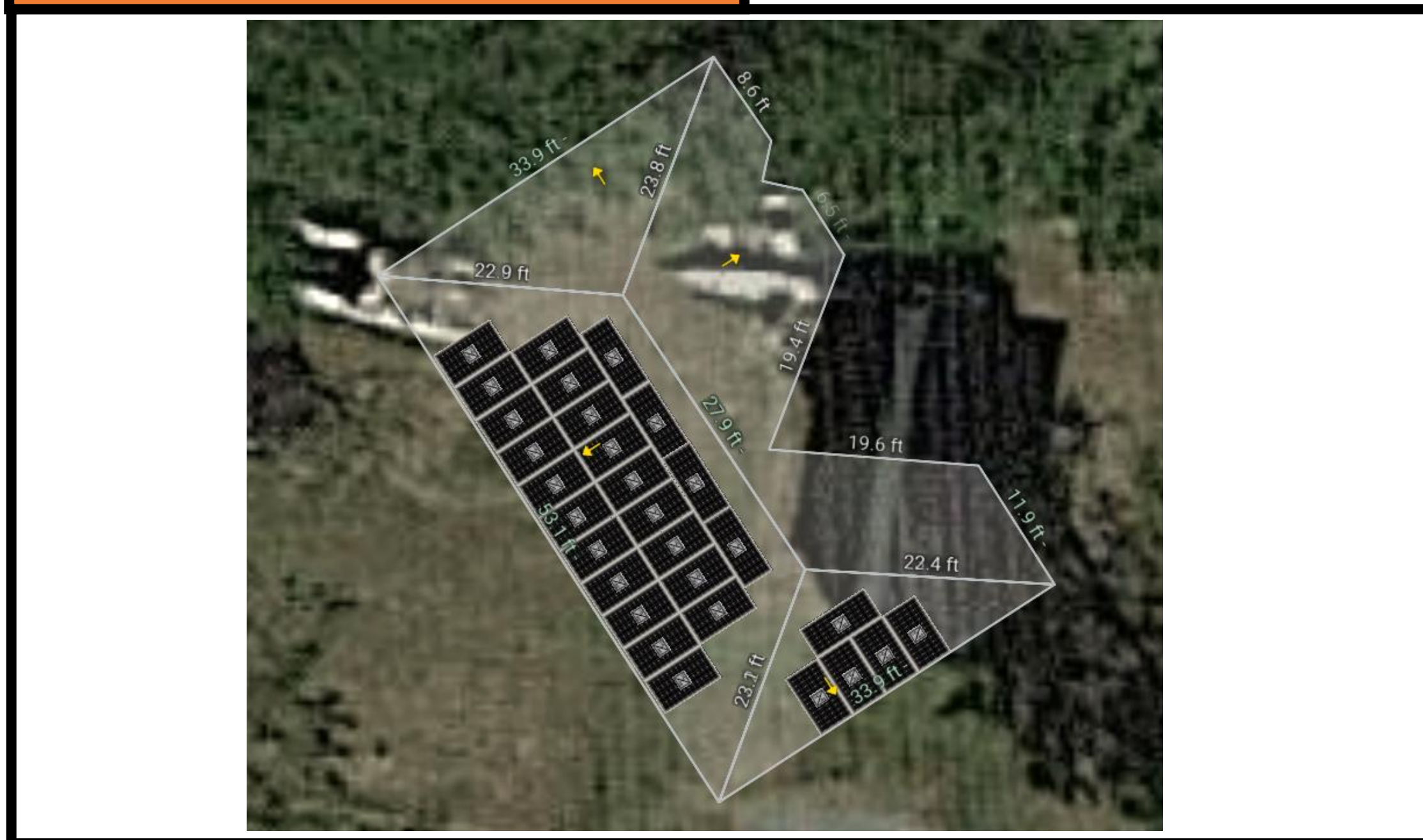

CODE SUMMARY

BUILDING	ELECTRICAL	STATE	FIRE
2018 IBC	2017 NEC	NORTH CAROLINA	NFPA 2015 EDITION 1

TABLE OF CONTENT

- C-1: COVER PAGE
- E-1: ELECTRICAL AND CALCULATIONS
- S-1: STRUCTURAL DIAGRAM
- S-2: STRUCTURAL CALCULATIONS

PROJECT/PERMITTING NOTES

PROJECT: INSTALLATION OF GRID-TIED PHOTOVOLTAIC SYSTEM

SEAL:



REVISION/NOTES:

PROJECT: Dawkins, Andre
86 Centennial Parkway
Cameron, NC 283226
Cover Page



SCALE: NTS
DRAWN BY: B.G.
DATE: 09/16/2020
PAGE:

C-1

XR Rails

XR10 Rail
A low-profile mounting rail for regions with light snow.

XR100 Rail
The ultimate residential solar mounting rail.

XR1000 Rail
A heavyweight mounting rail for commercial projects.

Internal Splices
All rails use internal splices for seamless connections.

Attachments

FlashFoot
Anchor, flash, and mount with all-in-one attachments.

Slotted L-Foot
Drop-in design for rapid rail attachment.

Standoffs
Raise flush or tilted systems to various heights.

Tilt Legs
Tilt assembly to desired angle, up to 45 degrees.

Clamps & Grounding

End Clamps
Slide in clamps and secure modules at ends of rails.

Grounding Mid Clamps
Attach and ground modules in the middle of the rail.

T-Bolt Grounding Lugs
Ground system using the rail's top slot.

Accessories
Provide a finished and organized look for rails.

Free Resources

Design Assistant
Go from rough layout to fully engineered system. For free. Go to IronRidge.com/vm

NABCEP Certified Training
Earn free continuing education credits, while learning more about our systems. Go to IronRidge.com/training

Tech Brief

XR Rail Family

The XR Rail Family offers the strength of a curved rail in three targeted sizes. Each size supports specific design loads, while minimizing material costs. Depending on your location, there is an XR Rail to match.

XR10
XR10 is a sleek, low-profile mounting rail, designed for regions with light or no snow. It achieves 6 foot spans, while remaining light and economical.

XR100
XR100 is the ultimate residential mounting rail. It supports a range of wind and snow conditions, while also maximizing spans up to 8 feet.

XR1000
XR1000 is a heavyweight among solar mounting rails. It's built to handle extreme climates and spans 12 feet or more for commercial applications.

Rail Selection

The following table was prepared in compliance with applicable engineering codes and standards. Values are based on the following criteria: ASCE 7-10, Roof Zone 1, Exposure B, Roof Slope of 7 to 27 degrees and Mean Building Height of 30 ft. Visit IronRidge.com for detailed span tables and certifications.

Allowable Spans

The following table was prepared by IronRidge to translate common site conditions into wind uplift pressures and span values (engineering assumptions below). Alternatively, the prescriptive roof pressures defined in RAS 127 tables 1 & 2 can be used.

Roof Zone	Exposure Category	Parameters		Approved Span (in)										
		Wind Speed (MPH)	Uplift (PSF)	16	24	32	36	48	60	84	72			
1	B & C	150	-28	XR10									XR100	
		160	-32											
		170	-36											
		175	-39											
	D	180	-41											
		150	-34											
		160	-38											
		170	-43											
2	B	150	-20											
		160	-23											
		170	-26											
		150	-48											
	C	160	-54											
		170	-61											
		175	-65											
		180	-69											
D	150	-57	XR100 (or XR10 3-Rail)											
	160	-64												
	170	-73												
	175	-77												

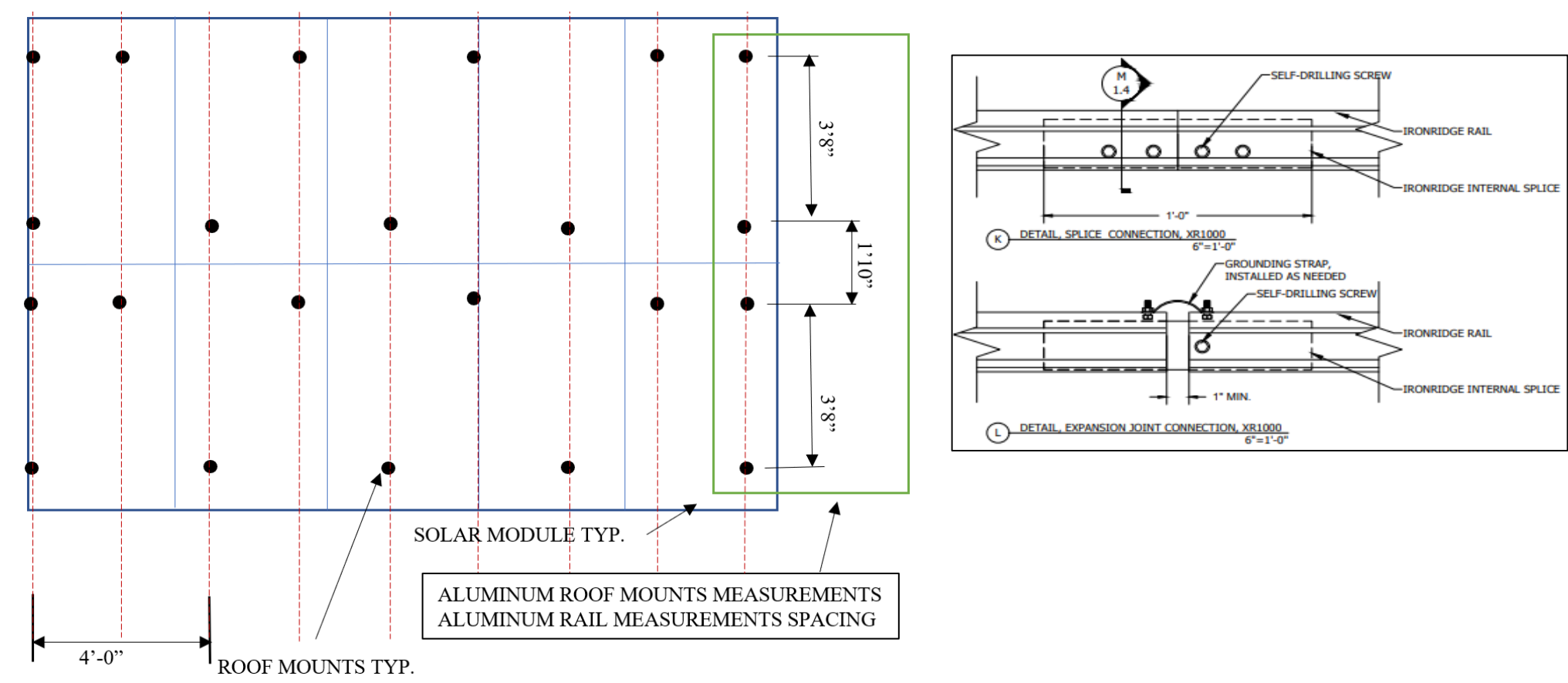

ROOF AREA

EXISTING SHINGLE ROOF
TOTAL ROOF AREA: 3,574 sq-ft
TOTAL PHOTOVOLTAIC AREA: 774 sq-ft
PERIMETER WIDTH: 4.3'
PRESSURE ZONE: 1 & 2
ROOF SLOPE: 12:12
TRUSS SIZE: 2 x 4
TOTAL MODULES: 29
MIN. ROOF MOUNTS: 66
TOTAL POINT OF CONNECTIONS PER MODULE: 4
ALUMINUM RAILS: 2

SEAL:

REVISION/NOTES:



SM SOLAR MOUNT

CODE COMPLIANCE NOTES

INSTALLATION GUIDE

SYSTEM LEVEL FIRE CLASSIFICATION

The system fire class rating requires installation in the manner specified in the SOLARMOUNT Installation Guide. SOLARMOUNT has been classified to the system level fire portion of UL 1703. This UL 1703 classification has been incorporated into our UL 2703 product certification. SOLARMOUNT has achieved system level performance for steep sloped roofs. System level fire performance is inherent in the SOLARMOUNT design, and no additional mitigation measures are required. The fire classification rating is only valid on roof pitches greater than 2:12 (slopes > 2 inches per foot, or 9.5 degrees). The system is to be mounted over fire resistant roof covering rated for the application. There is no required minimum or maximum height limitation above the roof deck to maintain the system fire rating for SOLARMOUNT. Module Types & System Level Fire Ratings are listed below:

Rail Type	Module Type	System Level Fire Rating	Rail Direction	Module Orientation	Mitigation Required
Standard Rail	Type 1, Type 2, Type 3 & Type 10	Class A, Class B & Class C	East-West	Landscape OR Portrait	None Required
			North-South	Landscape OR Portrait	None Required
Light Rail	Type 1 & Type 2	Class A, Class B & Class C	East-West	Landscape OR Portrait	None Required
			North-South	Landscape OR Portrait	None Required

This racking system may be used to ground and/or mount a PV module complying with UL1703 only when the specific module has been evaluated for grounding and/or mounting in compliance with the included instructions.

UL2703 CERTIFICATION MARKING LABEL

Unirac SOLARMOUNT is listed to UL 2703. Certification marking is embossed on all mid clamps as shown. Labels with additional information will be provided. After the racking system is fully assembled, a single label should be applied to the SOLARMOUNT rail at the edge of the array. Note: The sticker label should be placed such that it is visible, but not outward facing.

SM STANDARD RAIL

SM LIGHT RAIL

JINKO 400W

39.45"

79.06"

ALLOWABLE LOAD: (5,400psf) 113 psf

NOTE: Install mid clamps between modules and end clamps at the end of each row of modules.

SOLAR MODULE

NOTE: ALUMINUM RAILS SHOULD ALWAYS BE SUPPORTED BY MORE THAN ONE FOOTING ON BOTH SIDES OF THE SPLICE.

BONDING MIDCLAMP ASSEMBLY

- 1 Stainless steel Midclamp points, 2 per module, pierce module frame anodization to bond module to module through clamp.
- 2 Serrated flange nut bonds stainless steel clamp to stainless steel T-bolt
- 3 Serrated T-bolt head penetrates rail anodization to bond T-bolt, nut, clamp, and modules to grounded SM rail.

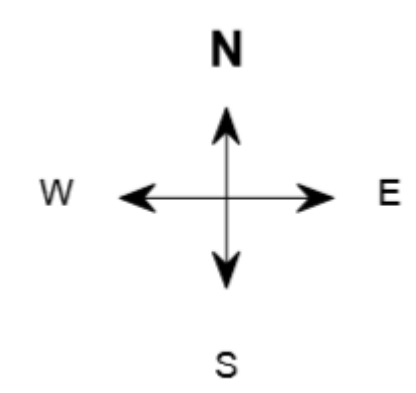

SCALE: NTS
DRAWN BY: B.G.
DATE: 09/16/2020
PAGE:
S-1

PROJECT: Dawkins, Andre
86 Centennial Parkway
Cameron, NC 283226
Structural Diagram

G SOLAR POWER™

933 Clint Moore Road
Boca Raton, FL 33487
(800) 530-9597
CVC56962

DESIGN WIND PRESSURE CALCULATIONS FOR SOLAR MODULES INSTALLED ON ROOFS

IBC EDITION	2018	RISK CATEGORY	II
MEAN ROOF HEIGHT (ft.)	14	EXPOSURE CATEGORY	C
LENGTH (ft.)	57	ROOF SLOPE (SHINGLE)	12:12
WIDTH (ft.)	49	ROOF SLOPE (DEGREE)	45.0°
EFFECTIVE WIND AREA (ft ²)	18.0	ROOF TYPE	GABLE
PARAPET HEIGHT (ft.)	0	ULTIMATE WIND SPEED	175 mph
MODULE LENGTH (in)	65	NOMINAL WIND SPEED	136 mph
MODULE WIDTH (in)	39.38	KD	0.85
		KZT	1.0
		KZ	0.85

DESIGN CALCULATIONS:
 VELOCITY PRESSURE (q) = 0.00256(KZ)(KZT)(KD)(V²)
 VELOCITY PRESSURE (qh) = 33.9 psf EQUATION 26.8-1
 INTERNAL PRESSURE COEFFICIENT (+/-) = 0.18

DESIGN PRESSURE EQUATION 30.9-1	DIRECTION - UP PSF	DIRECTION - DOWN PSF
ZONE 1	-39.2	35.8
ZONE 2	-60.0	35.8
ZONE 3	-81.0	35.8

GCP: FIGURE 30.4-2 B	DIRECTION - UP	DIRECTION - DOWN
ZONE 1	-1.0	0.9
ZONE 2	-1.6	0.9
ZONE 3	-2.2	0.9

ASCE 7-16 VELOCITY PRESSURE
 $q_z = 0.00256 K_z K_{DT} V^2$
 where:
 q_z = ASCE 7-16 velocity pressure evaluated at mean roof height (psf)
 K_z = velocity pressure exposure coefficient
 K_{DT} = topographic factor
 K_D = wind directionality factor
 V = basic wind speed (mph) from ASCE 7-16 maps referred to as ultimate wind speed maps in 2018 IBC.

As an example, for an array having an array of 158.04 sq.-ft., the total uplifting (resultant) force acting on the array would be -39.1 psf x 158.04 sq.-ft. = -6,179.364 lb. Knowing this resultant force, the design engineer can now determine the number of attached points and the size of the mounting hardware necessary to safely carry this load.

LIVE LOADS:
 Live loads associated with photovoltaic systems are usually assumed to be distributed uniformly and are small, on the order of 4 psf or less.

NOTES:
 These calculations are based on the C&C Wind Loads for Enclosed Buildings. Design wind pressures are calculated using ASCE 7-10 equation in 30.6-1. All notes in Figures 30.4-1, and 30.4-2 (A, B, AND C) have been incorporated. Mean roof height must be less than 60 feet.

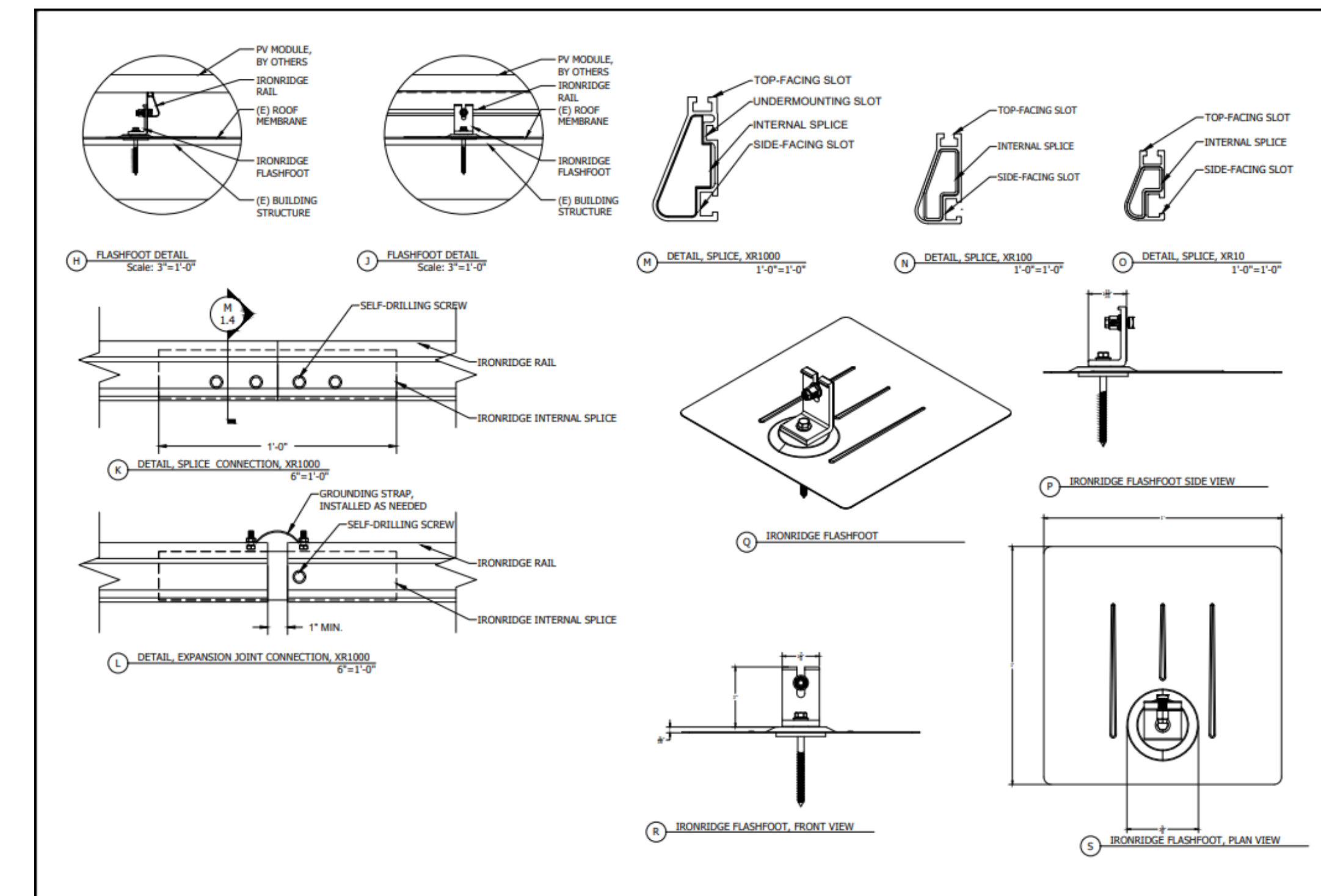

Lag Screw Installation Guidelines

- Determine location for the L-Bracket on roof by drilling through the center of truss from bottom with 5/32" drill bit.
- Mark mounting holes for L-Bracket on underlayment. Mounting holes should be centered on the trusses.
- Drill 15/64" pilot hole.
- Apply sealant to bottom of L-Bracket.
- Place L-Bracket over roof underlayment with holes in roof.
- Apply sealant to bottom of L-Bracket, apply sealant to lag screws, and fasten L-Bracket securely to trusses.
- Apply additional sealant to top assembly to be sure all penetrations are sealed.

Species	Spec'ic gravity	1/4" shaft, * per inch thread depth
Douglas Fir, Larch	0.50	266
Douglas Fir, South	0.46	235
Engelmann Spruce, Lodgepole Pine (MSR 1650 ft & higher)	0.46	235
Hem, Fir, Redwood (close grain)	0.43	212
Hem, Fir (North)	0.46	235
Southern Pine	0.55	307
Spruce, Pine, Fir	0.42	205
Spruce, Pine, Fir (E of 2 million psi and higher grades of MSR and MEL)	0.50	266

Sources: American Wood Council, NDS 2005, Table 11.2A, 11.3.2A
 Notes: (1) Truss must be embedded in the side grain of a trusses or other structural member integral with the building structure.
 (2) Lag bolts must be located in the middle third of the structural member.
 (3) These values are not valid for wet service.
 (4) This table does not include shear capacities. If necessary, contact a local engineer to specify lag bolt size with regard to shear forces.
 (5) Install lag bolts with head and washer flush to surface (no gap). Do not over-torque.
 (6) Withdrawal design values for lag screw connections shall be multiplied by applicable adjustment factors if necessary. See Table 10.3.1 in the American Wood Council NDS for Wood Construction.

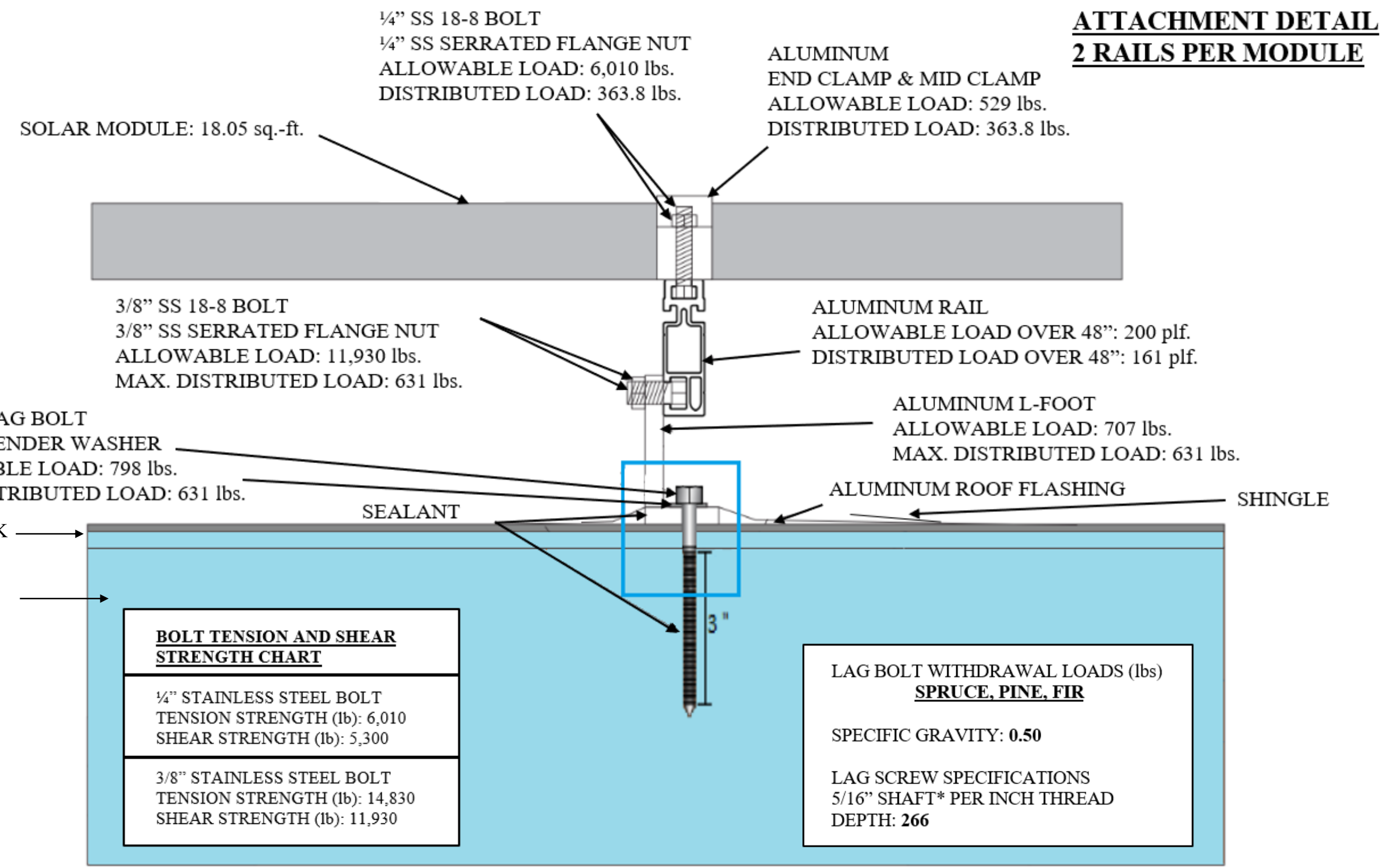

*Rails, L-Foot, Mid-clamps & End-clamps are extruded using one of the following aluminum alloys: 6005-T5, 6105-T5, 6061-T6 Sources: American Wood Council, NDS 2005, Table 11.2A, 11.3.2A

Array Wind Load Calculations		Lag Bolt Pull Out Calculations	
Solar Panel	11	Spruce, Pine	Per Inch Thread Depth 266 lbs.
Total Area (sq.ft.)	198.55	SS Lag Bolt 5/16" x 4"	Min. Thread Depth 3"
Wind Load (psf.)	-60.0	Wood Strength x Thread Depth = Pull Out Strength	
Total Wind Loads (lbs.)	-11,913.0	266 lbs. x 3" = 789 lbs.	
Total Roof Mounts (#)	22	Allowable Pull Out Strength Required per Lag Bolt	798 lbs.
Tension Force per Mount (lbs.)	-531.5725	Max. Pull Out Strength Required per Lag Bolt	-531.6 lbs.
Tension force per LAG-BOLT (lbs.)	-531.6	Lag Bolt Pull Out Strength Safety Factor	1.5

Technical Data Sheet Polyether Technology CSI Section No. 07 92 13

CHEM LINK Construction & Maintenance
 Telephone: 300-526-1681
 Fax: 269-679-4448
 353 E. Lyons Street
 Schoolcraft, MI 49087
www.chemlink.com

Product Description
 DuraLink 50 is an extremely elastic moisture curing sealant designed for use in cementitious siding, metal architecture, curtain wall construction and joints subject to movement. DuraLink 50's adhesion to difficult surfaces permits its use on anodized metal and coatings such as Kynar 500® PVDF. DuraLink 50 will not stain absorbent stone substrates like limestone or marble. DuraLink 50's unique polyether chemistry eliminates out-gassing on green concrete and protects against "sun tanning" or discoloration when exposed to ultraviolet light.

Advantages

- Bonds to Kynar 500® PVDF coated metal
- Solvent free, 100% solids will not shrink
- Non-slump, applies vertically and overhead
- 40 minute skin over
- No outgassing on damp surfaces
- Available in a wide range of roofing & siding colors
- Color stability will not suntan
- Paintable within 24 hours (See limitations)
- +/- 50% joint movement

Colors
 Please refer to applied color board or chemlink.com for a full list of roofing and siding colors. Special colors are available upon request.

Packaging

- 10.1 oz (300 ml) Euro / 4inch nozzle
- 12 cartridges/carton, 105 cartons/pallet
- 24 cartridges/carton, 45 cartons/pallet
- 20 oz (600 ml)
- 12 sausages/carton, 40 cartons/pallet
- 2 and 5 gallon pails or 50 gallon drums available by special order

Regulatory Compliance

- Conforms to OTC Rule for Sealants
- Meets requirements of California Regs: CARB, BAAQMD and SCAQMD
- This product does not contain cancer causing chemicals listed in California Proposition 65
- Conforms to USDA Requirements for Non-food Contact

Green Standards:

- LEED 2.2 for New Construction and Major Renovations: Low Emitting Materials (Section 4.1) 1 Point
- NAHB Model Green Home Building Guidelines: 5 Global Impact Points
- VOC Content: less than 22 grams / liter ASTM D2369 EPA Method 24 (tested at 240°F / 115°C)

The Strongest Attachment in Solar

IronRidge FlashFoot2 raises the bar in solar roof protection. The unique water seal design is both elevated and encapsulated, delivering redundant layers of protection against water intrusion. In addition, the twist-on Cap perfectly aligns the rail attachment with the lag bolt to maximize mechanical strength.

Twist-On Cap
 FlashFoot2's unique Cap design encapsulates the lag bolt and locks into place with a simple twist. The Cap helps FlashFoot2 deliver superior structural strength, by aligning the rail and lag bolt in a concentric load path.

Three-Tier Water Seal
 FlashFoot2's seal architecture utilizes three layers of protection. An elevated platform diverts water away, while a stack of rugged components raises the seal an entire inch. The seal is then fully encapsulated by the Cap. FlashFoot2 is the first solar attachment to pass the TAS-100 Wind-Driven Rain Test.

Single Socket Size
 A custom-design lag bolt allows you to install FlashFoot2 with the same 7/16" socket size used on other Flash Mount System components.

Water-Shedding Design
 An elevated platform diverts water away from the water seal.

SEAL:



REVISION/NOTES:

PROJECT: Dawkins, Andre
 86 Centennial Parkway
 Cameron, NC 283226
 Structural Calculations

933 Clint Moore Road
 Boca Raton, FL 33487
 (800) 530-9597
 CVC56962

SCALE: NTS
 DRAWN BY: B.G.
 DATE: 09/16/2020
 PAGE: