



10345 Nations Ford Rd Charlotte, NC 28273  
 Array@accelerate-solar.com  
 (877) 997-7652

Customer Name	Address	Date	Phone
Michele Florence	50 Atkins Pl Cir, Fuquay-Varina, NC 27526	8/18/2020	(757) 206-4804



Component	Name	Size
Modules	(22) Silfab SIL330BL (2020)	7.3 kW-DC
Inverter(s)	(1) SolarEdge SE6000H-US	6 kW-AC
Optimizers	(22) SolarEdge Optimizers	

### GENERAL NOTES

1	Inverter and AC disconnect shall be installed in locations that satisfy minimum working clearances per NEC section 110.26.
2	Contractor shall use only components listed by a nationally recognized testing laboratory for the intended use.
3	Contractor is responsible for furnishing all related equipment, cables, additional conduits, boxes, raceways, and other accessories necessary for a complete and operational PV system.
4	The system shall comply with all manufacturers listing and installation instructions, as well as all relevant sections of the 2017 NEC (NFPA 70) and all other codes specified by the authority having jurisdictions (AHJ).
5	Where DC PV source or DC PV output circuits are run inside the building, they shall be contained in metal raceways, type MC metal-clad cable, or metal enclosures from the point of penetration into the building to the first readily accessible disconnecting means, per NEC section 690.31(G).

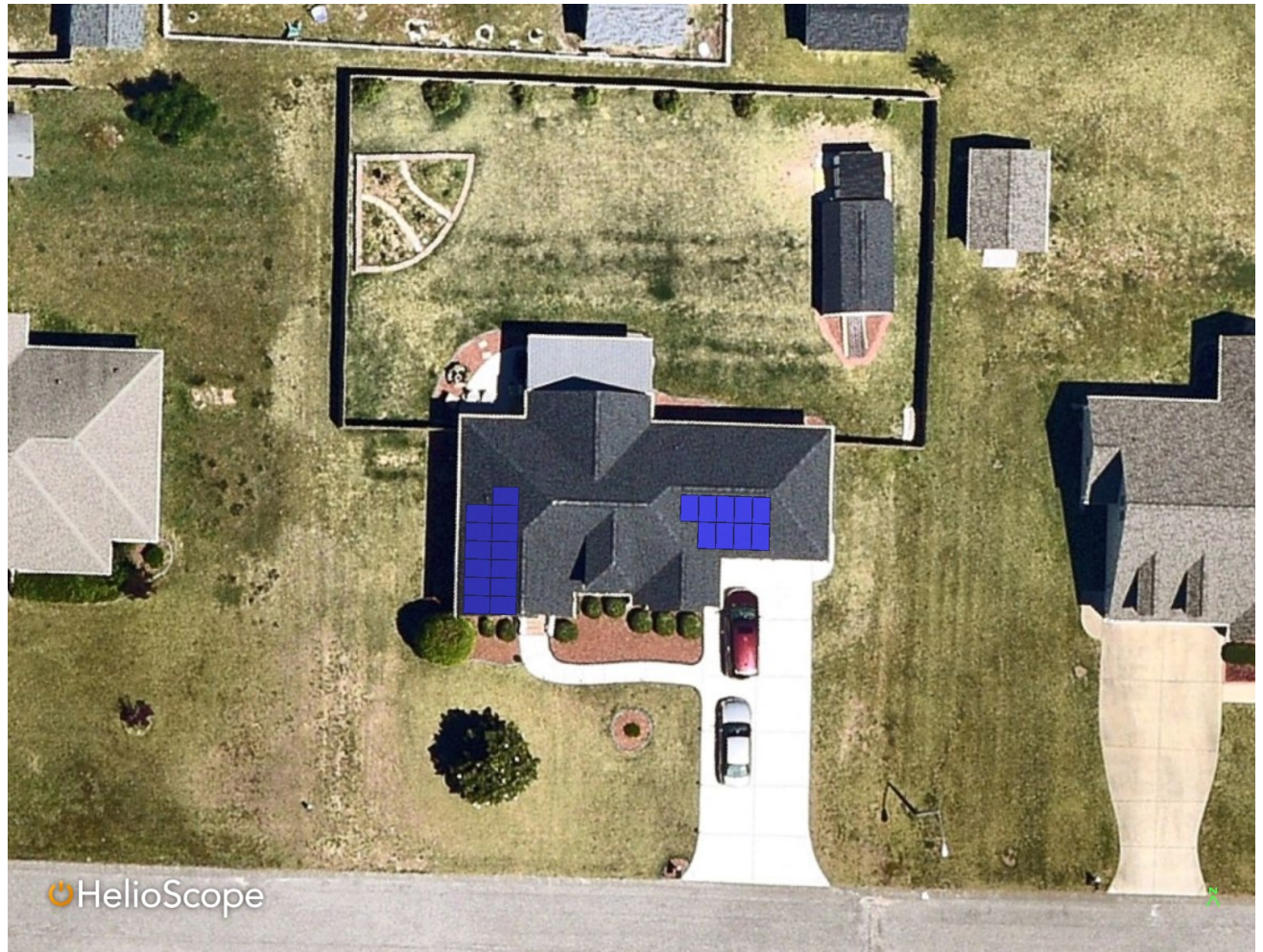

SITE PLAN (Aerial View)

THIS DOCUMENT HAS BEEN CREATED FOR THE PURPOSE OF DESCRIBING THE DESIGN OF A PROPOSED PHOTOVOLTAIC POWER SYSTEM WITH ENOUGH DETAIL TO DEMONSTRATE COMPLIANCE WITH ALL APPLICABLE CODES AND REGULATIONS. THE DOCUMENT SHOULD NOT BE RELIED UPON AS A SUBSTITUTE FOR FOLLOWING MANUFACTURER INSTALLATION MANUALS. INSTALLER SHALL INSTALL ALL EQUIPMENT IN ACCORDANCE WITH MANUFACTURER INSTALLATION MANUALS. NOTHING IN THIS DOCUMENT SHOULD BE INTERPRETED IN A WAY THAT OVERRIDES THE INSTRUCTIONS IN MANUFACTURER INSTALLATION MANUALS.



# ACCELERATE SOLAR

10345 Nations Ford Rd Charlotte, NC 28273  
Array@accelerate-solar.com  
(877) 997-7652

Customer Name	Address	Date	Phone
Michele Florence	50 Atkins Pl Cir, Fuquay-Varina, NC 27526	8/18/2020	(757) 206-4804

Component	Name	Size
Modules	(22) Silfab SIL330BL (2020)	7.3 kW-DC
Inverter(s)	(1) SolarEdge SE6000H-US	6 kW-AC
Optimizers	(22) SolarEdge Optimizers	



# DUKE ENERGY®

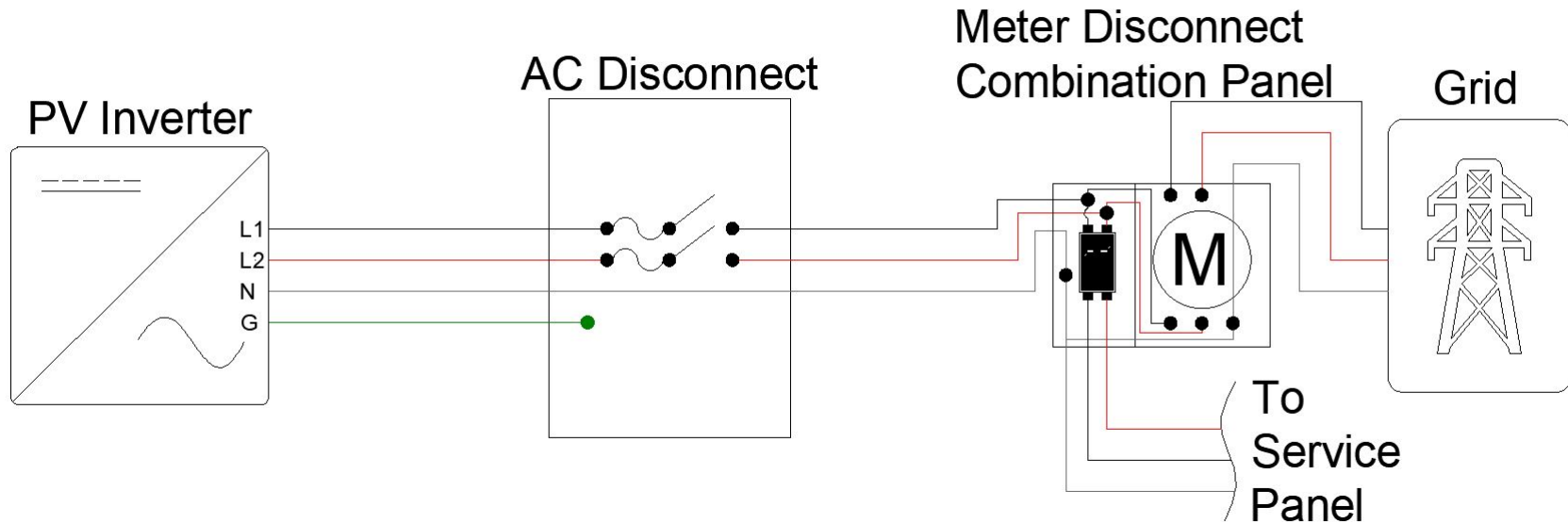

## INTERCONNECTION DIAGRAM ( )

THIS DOCUMENT HAS BEEN CREATED FOR THE PURPOSE OF DESCRIBING THE DESIGN OF A PROPOSED PHOTOVOLTAIC POWER SYSTEM WITH ENOUGH DETAIL TO DEMONSTRATE COMPLIANCE WITH ALL APPLICABLE CODES AND REGULATIONS. THE DOCUMENT SHOULD NOT BE RELIED UPON AS A SUBSTITUTE FOR FOLLOWING MANUFACTURER INSTALLATION MANUALS. INSTALLER SHALL INSTALL ALL EQUIPMENT IN ACCORDANCE WITH MANUFACTURER INSTALLATION MANUALS. NOTHING IN THIS DOCUMENT SHOULD BE INTERPRETED IN A WAY THAT OVERRIDES THE INSTRUCTIONS IN MANUFACTURER INSTALLATION MANUALS.



# ACCELERATE SOLAR

10345 Nations Ford Rd Charlotte, NC 28273  
 Array@accelerate-solar.com  
 (877) 997-7652

Customer Name	Address	Date	Phone
Michele Florence	50 Atkins Pl Cir, Fuquay-Varina, NC 27526	8/18/2020	(757) 206-4804

### SOLAR PV OVERVIEW

PV Array:	7.3 kW-DC
Inverter(s):	6 kW-AC - 25 A
AC Utility:	240 VAC - 60 Hz

### MODULE SPECIFICATIONS

Panels	(22) Silfab SIL330BL (2020)
STC Rating	325 W
Vmp	33 V
Imp	9 A
Voc	40 V
Isc	10 A

### INVERTER SPECIFICATIONS

Inverter(s)	(1) SolarEdge SE6000H-US
Max AC Power	6 kW-AC
Max Input Voltage	480 V
Min AC Power	0 W
Min Input Voltage	340 V

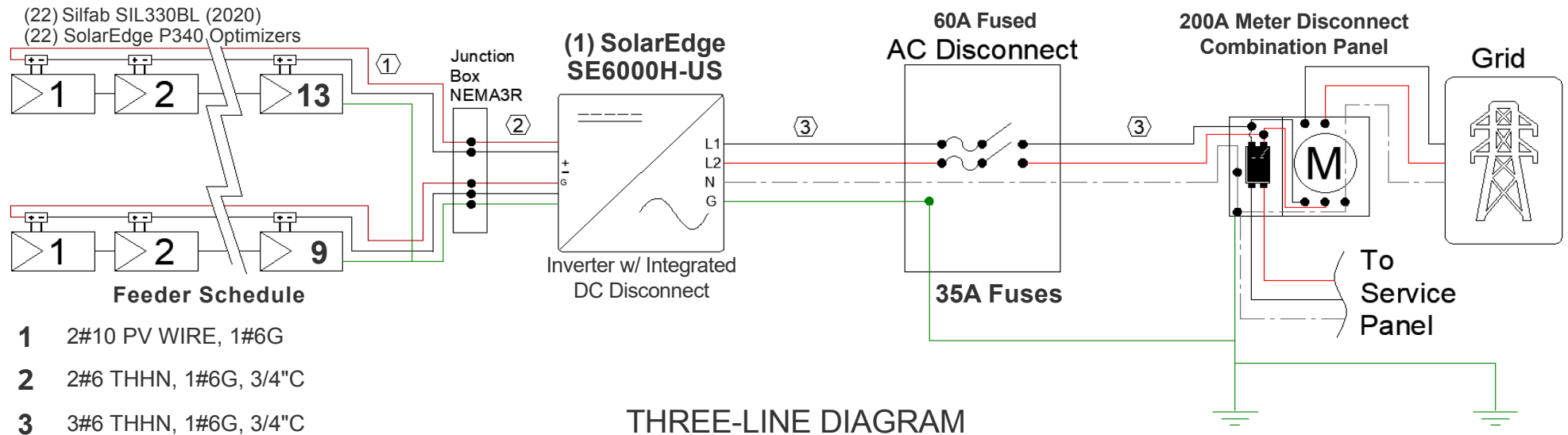

### GROUNDING NOTES

1	ALL EQUIPMENT SHALL BE PROPERLY GROUNDED PER THE REQUIREMENTS OF NEC ARTICLES 250 & 690
2	PV MODULES SHALL BE GROUNDED TO MOUNTING RAILS USING MODULE LUGS OR RACKING INTEGRATED GROUNDED CLAMPS AS ALLOWED BY LOCAL JURISDICTION. ALL OTHER EXPOSED METAL PARTS SHALL BE GROUNDED USING UL-LISTED LAY-IN LUGS
3	GROUNDED SYSTEM COMPONENTS SHALL BE LISTED FOR THEIR PURPOSE
4	IF THE EXISTING MAIN SERVICE PANEL DOES NOT HAVE A VERIFIABLE GROUNDED ELECTRODE, IT IS THE CONTRACTOR'S RESPONSIBILITY TO INSTALL A SUPPLEMENTAL GROUNDED ELECTRODE
5	AC SYSTEM GROUNDED ELECTRODE CONDUCTOR (GEC) SHALL BE A MINIMUM SIZE #8 AWG WHEN INSULATED, #6 AWG IF BARE WIRE
6	EQUIPMENT GROUNDED CONDUCTORS SHALL BE SIZED ACCORDING TO NEC ARTICLE 690.45, AND BE A MINIMUM OF #10 AWG WHEN NOT EXPOSED TO DAMAGE, AND #6 AWG SHALL BE USED WHEN EXPOSED TO DAMAGE
7	GROUNDED AND BONDING CONDUCTORS, IF INSULATED, SHALL BE COLOR CODED GREEN, OR MARKED GREEN IF #4 AWG OR LARGER





# ACCELERATE SOLAR

10345 Nations Ford Rd Charlotte, NC 28273

Array@accelerate-solar.com

(877) 997-7652

Customer Name	Address	Date	Phone
Michele Florence	50 Atkins Pl Cir, Fuquay-Varina, NC 27526	8/18/2020	(757) 206-4804

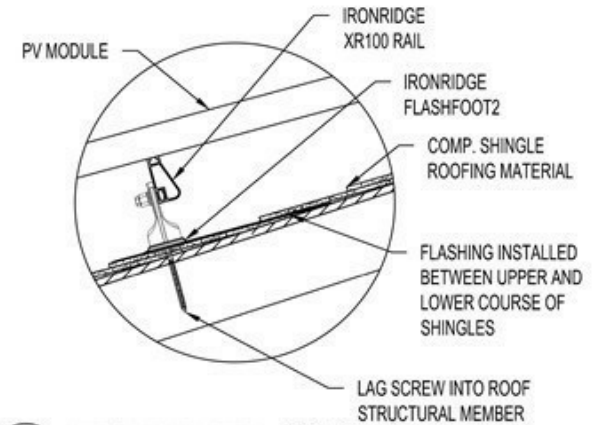
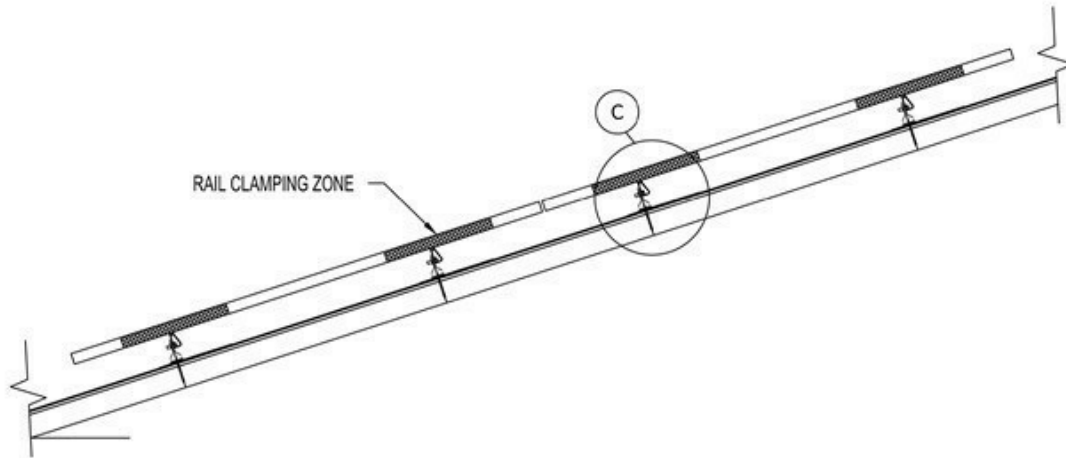

**C ATTACHMENT DETAIL (TRANSVERSE VIEW)**  
PV-6 SCALE: NTS

### MOUNTING NOTES

- |   |                                                                                                                                                    |
|---|----------------------------------------------------------------------------------------------------------------------------------------------------|
| 1 | FLASHING SHALL BE APPLIED IN ACCORDANCE WITH MANUFACTURERS' PRINTED INSTRUCTIONS.                                                                  |
| 2 | IF THERE IS ANY CONFLICT BETWEEN WHAT IS DEPICTED HERE AND INSTRUCTIONS PROVIDED BY THE MANUFACTURER, MANUFACTURERS' INSTRUCTIONS SHALL SUPERCEDE. |

**A RACKING ELEVATION (TRANSVERSE VIEW)**  
PV-6 SCALE: NTS

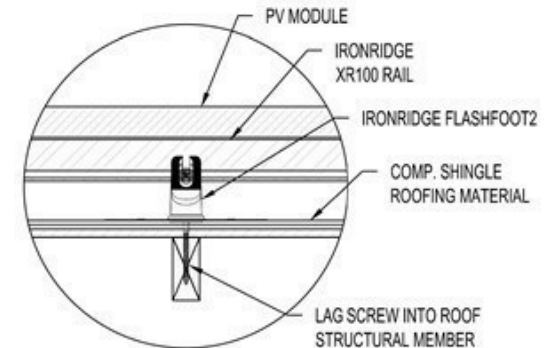
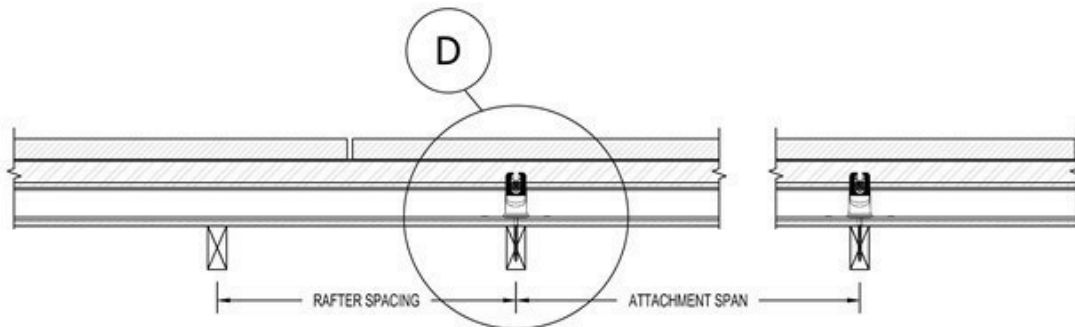

**D ATTACHMENT DETAIL (LONGITUDINAL VIEW)**  
PV-6 SCALE: SCALE

**B RACKING ELEVATION (LONGITUDINAL VIEW)**  
PV-6 SCALE: NTS





# ACCELERATE SOLAR

10345 Nations Ford Rd Charlotte, NC 28273  
Array@accelerate-solar.com  
(877) 997-7652

Customer Name	Address	Date	Phone
Michele Florence	50 Atkins Pl Cir, Fuquay-Varina, NC 27526	8/18/2020	(757) 206-4804

## ! WARNING

ELECTRICAL SHOCK HAZARD

1

WARNING: PHOTOVOLTAIC POWER SOURCE

2

PHOTOVOLTAIC SYSTEM EQUIPPED WITH  
RAPID SHUTDOWN.

3

! WARNING - DUAL POWER SOURCE  
SECOND SOURCE IS PHOTOVOLTAIC SYSTEM

4

PHOTOVOLTAIC  
DC DISCONNECT

5

PHOTOVOLTAIC AC DISCONNECT  
MAX AC OPERATING CURRENT: \_\_\_A  
NOM OPERATING AC VOLTAGE: \_\_\_V

6

! CAUTION  
PHOTOVOLTAIC SYSTEM IS BACKFED

7



### DC RACEWAYS

2

### MAIN SERVICE PANEL

4, 7

### INVERTER w/ DC DISCONNECT

1, 3, 5

### AC COMBINER PANEL

1, 4

### AC DISCONNECT

1, 4, 6

### UTILITY METER

4

### LABELING NOTES

1	ALL PLAQUES AND SIGNAGE REQUIRED BY 2014 NEC AND 2015 IFC WILL BE INSTALLED AS REQUIRED.
2	LABELS, WARNING(S) AND MARKING SHALL COMPLY WITH ANSI Z535.4, WHICH REQUIRES THAT DANGER, WARNING, AND CAUTION SIGNS USED THE STANDARD HEADER COLORS, HEADER TEXT, AND SAFETY ALERT SYMBOL ON EACH LABEL. THE ANSI STANDARD REQUIRES A HEADING THAT IS AT LEAST 50% TALLER THAN THE BODY TEXT, IN ACCORDANCE WITH NEC SECTION 110.21(B).
3	A PERMANENT PLAQUE OR DIRECTORY SHALL BE INSTALLED PROVIDING THE LOCATION OF THE SERVICE DISCONNECTING MEANS AND THE PHOTOVOLTAIC SYSTEM DISCONNECTING MEANS IF NOT IN THE SAME LOCATION IN COMPLIANCE NEC SECTION 690.56(B).
4	WHERE THE INVERTERS ARE REMOTELY LOCATED FROM EACH OTHER, A DIRECTORY SHALL BE INSTALLED AT EACH DC PHOTOVOLTAIC SYSTEM DISCONNECTING MEANS, AT EACH AC IS CONNECTING MEANS, AND AT THE MAIN SERVICE DISCONNECTING MEANS SHOWING THE LOCATION OF ALL AC AND DC PHOTOVOLTAIC SYSTEM DISCONNECTING MEANS IN THE BUILDING, IN ACCORDANCE WITH NEC SECTION 690.4(H).
5	LABEL(S) WITH MARKING "WARNING: PHOTOVOLTAIC POWER SOURCE" SHALL BE LOCATED AT EVERY 10 FEET OF EACH DC RACEWAY AND WITHIN ONE FOOT OF EVERY TURN OR BEND AND WITHIN ONE FOOT ABOVE AND BELOW ALL PENETRATIONS OF ROOF/CEILING ASSEMBLIES, WALLS AND BARRIERS. THE LABEL SHALL HAVE 3/8" TALL LETTERS AND BE REFLECTIVE WITH WHITE TEXT ON A RED BACKGROUND.
6	LABEL(S) WITH MARKING "PHOTOVOLTAIC SYSTEM EQUIPPED WITH RAPID SHUTDOWN" SHALL BE LOCATED AT POINT-OF-INTERCONNECTION OR AT MAIN SERVICE DISCONNECT. THE LABEL SHALL HAVE 3/8" TALL LETTERS AND BE REFLECTIVE WITH WHITE TEXT ON A RED BACKGROUND.



# BC Series SIL-330 BL



## 126 Cell Monocrystalline PV Module

### INDUSTRY LEADING WARRANTY

All our products include an industry leading 25-year product workmanship and 30-year performance warranty.

### MAXIMUM ENERGY OUTPUT

Silfab BC Series utilizes next generation Back Contact technology to reduce production/manufacturing steps and improve quality while maximizing power. Ideal for residential and commercial projects where maximum power density is preferred.

### NORTH AMERICAN QUALITY

Silfab is the leading automated solar module manufacturer in North America. Utilizing premium quality materials and strict quality control management to deliver the highest efficiency, premium quality PV modules 100% made in North America.

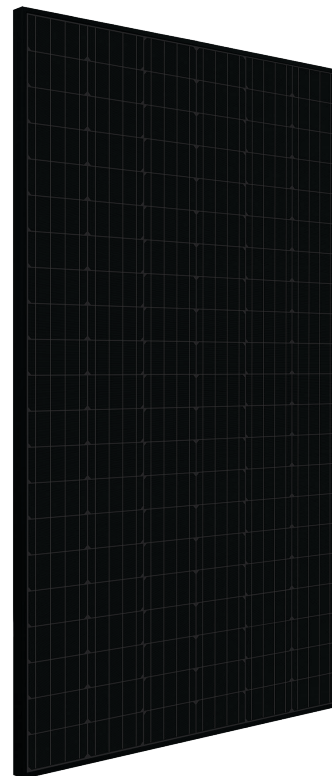

CHUBB®

\* Chubb provides error and omission insurance to Silfab Solar Inc.

### PROVIDES MAXIMUM EFFICIENCY

126 high-efficiency half-cut cells combined with a black conductive back-sheet resulting in a maximum power rating of 330Wp.

### 35+ YEARS OF SOLAR INNOVATION

Leveraging over 35+ years of worldwide experience in the solar industry, Silfab is dedicated to superior manufacturing processes and innovations such as Bifacial and Back Contact technologies to ensure our partners have the latest in solar innovation.

### BAA / ARRA COMPLIANT

Silfab panels are designed and manufactured to meet Buy American Act Compliance. The US State Department, US Military and FAA have all utilized Silfab panels in their solar installations.

### LIGHT AND DURABLE

Engineered to accommodate low load bearing structures up to 5400Pa. The light-weight frame is exclusively designed for wide-ranging racking compatibility and durability.

### QUALITY MATTERS

Total automation ensures strict quality controls during the entire manufacturing process at our ISO certified facilities.

### DOMESTIC PRODUCTION

Silfab Solar manufactures PV modules in two automated locations within North America. Our 500+ North American team is ready to help our partners win the hearts and minds of customers, providing customer service and product delivery that is direct, efficient and local.

### SUPERIOR POWER

Super power achieved through relocation of tabbing ribbon to reduce shading on module front service and circuit resistance.

### AESTHETICALLY PLEASING

Sleek aesthetics from black cells to black back-sheet without tabbing or bus-bar ribbons, ideal for residential applications.

### STABLE PERFORMANCE

Enhanced life-time performance through reduced thermal stresses and increased current flow paths.

### PID RESISTANT

PID Resistant due to advanced cell technology and material selection. In accordance to IEC 62804-1.

Electrical Specifications		SIL-330 BL mono PERC MWT Technology	
Test Conditions		STC	NOCT
Module Power (Pmax)	Wp	330	246.8
Maximum power voltage (Vpmax)	V	34.72	32.51
Maximum power current (Ipmax)	A	9.51	7.59
Open circuit voltage (Voc)	V	42.24	39.6
Short circuit current (Isc)	A	9.83	7.92
Module efficiency	%	19.4	18.14
Maximum system voltage (VDC)	V		1000
Series fuse rating	A		20
Power Tolerance	Wp		0 to +10

Measurement conditions: STC 1000 W/m<sup>2</sup> • AM 1.5 • Temperature 25 °C • NOCT 800 W/m<sup>2</sup> • AM 1.5 • Measurement uncertainty ≤ 3%  
 • Sun simulator calibration reference modules from Fraunhofer Institute. Electrical characteristics may vary by ±5% and power by 0 to +10W.

Temperature Ratings		SIL-330 BL mono PERC MWT Technology	
Temperature Coefficient Isc			+0.046 %/°C
Temperature Coefficient Voc			-0.279 %/°C
Temperature Coefficient Pmax			-0.377 %/°C
NOCT (± 2°C)			43.5 °C
Operating temperature			-40/+85 °C

Mechanical Properties and Components		SIL-330 BL mono PERC MWT Technology	
	Metric	Imperial	
Module weight	18.2 kg	40.1±0.4 lbs	
Dimensions (H x L x D)	1700 mm x 1000 mm x 38 mm	66.9 in x 39.4 in x 1.5 in	
Maximum surface load (wind/snow)*	4000 Pa rear load / 5400 Pa front load	83.5/112.8 lb/ft <sup>2</sup>	
Hail impact resistance	∅ 25 mm at 83 km/h	∅ 1 in at 51.6 mph	
Cells	126 high-efficiency half-cut mono-PERC MWT c-Si cells	126 high-efficiency half-cut mono-PERC MWT c-Si cells	
Glass	3.2 mm high transmittance, tempered, DSM anti-reflective coating	0.126 in high transmittance, tempered, DSM anti-reflective coating	
Cables and connectors (refer to installation manual)	Positive (1000 mm), Negative (1500 mm), ∅ 5.7 mm, MC4 compatible	Positive (39.4 in), Negative (59 in), ∅ 0.22 in, MC4 compatible	
Backsheet	Multilayer, integrated insulation film and electrically conductive backsheet		
Frame	Anodized Aluminum (Black)		
Bypass diodes	3 diodes-30SQ045T (45V max DC blocking voltage, 30A max forward rectified current)		
Junction Box	UL 3730 Certified, IP67 rated		

Warranties		SIL-330 BL mono PERC MWT Technology			
Module product workmanship warranty		25 years**			
Linear power performance guarantee		30 years			
		≥ 97% end 1 <sup>st</sup> year	≥ 90% end 12 <sup>th</sup> year	≥ 82% end 25 <sup>th</sup> year	≥ 80% end 30 <sup>th</sup> year

Certifications		SIL-330 BL mono PERC MWT Technology			
Product		ULC ORD C1703, UL 1703, CEC listed. Product durability proven up to 3 x IEC, climate chamber tests up to DH3000-TC600-HF30, UL Fire Rating: Type 1			
Factory		ISO9001:2015			

- Modules Per Pallet: 26
- Pallets Per Truck: 36
- Modules Per Truck: 936

\*Please refer to the Safety and Installation Manual for mounting specifications.

\*\*12 year extendable to 25 years subject to registration and conditions outlined under "Warranty" at [www.silfabsolar.com](http://www.silfabsolar.com).

\* ⚠ Warning: Read the installation and User Manual before handling, installing and operating modules.

Third-party generated pan files from Fraunhofer-Institute for Solar Energy Systems ISE are available for download at: [www.silfabsolar.com/downloads](http://www.silfabsolar.com/downloads)

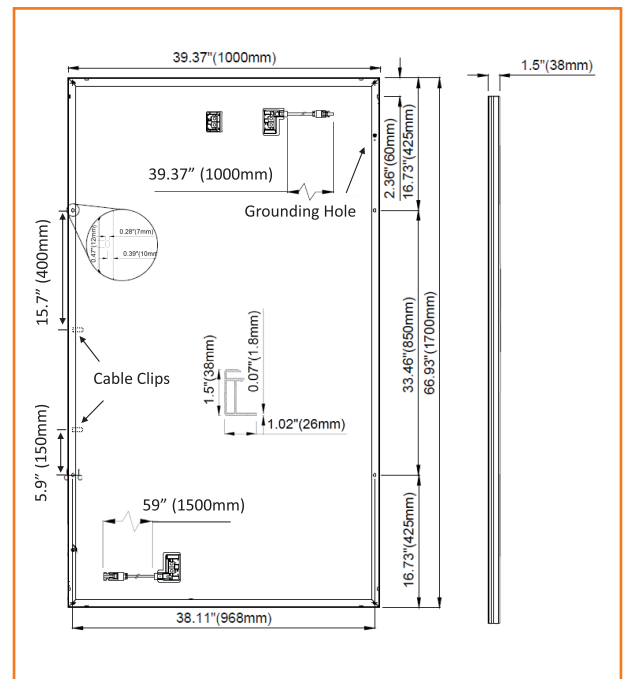

Silfab Solar Inc.  
 240 Courtneypark Drive East  
 Mississauga ON L5T 2Y3 Canada  
 Tel +1 905-255-2501 | Fax +1 905-696-0267  
 info@silfabsolar.com | www.silfabsolar.com



Silfab Solar Inc.  
 800 Cornwall Ave  
 Bellingham WA 98225 USA  
 Tel +1 360-569-4733



# Single Phase Inverter with HD-Wave Technology

for North America

SE3000H-US / SE3800H-US / SE5000H-US / SE6000H-US / SE7600H-US / SE10000H-US / SE11400H-US



INVERTERS

## Optimized installation with HD-Wave technology

- Specifically designed to work with power optimizers
- Record-breaking efficiency
- Quick and easy inverter commissioning directly from a smartphone using the SolarEdge SetApp
- Fixed voltage inverter for longer strings
- Integrated arc fault protection and rapid shutdown for NEC 2014 and 2017, per article 690.11 and 690.12
- UL1741 SA certified, for CPUC Rule 21 grid compliance
- Extremely small
- Built-in module-level monitoring
- Outdoor and indoor installation
- Optional: embedded consumption metering and production revenue grade metering, ANSI C12.20 Class 0.5 (0.5% accuracy)

[solaredge.com](http://solaredge.com)



## Single Phase Inverter with HD-Wave Technology for North America

SE3000H-US / SE3800H-US / SE5000H-US / SE6000H-US / SE7600H-US / SE10000H-US / SE11400H-US

MODEL NUMBER	SE3000H-US	SE3800H-US	SE5000H-US	SE6000H-US	SE7600H-US	SE10000H-US	SE11400H-US	
APPLICABLE TO INVERTERS WITH PART NUMBER	SEXXXH-XXXXBXX4							
<b>OUTPUT</b>								
Rated AC Power Output	3000	3800 @ 240V 3300 @ 208V	5000	6000 @ 240V 5000 @ 208V	7600	10000	11400 @ 240V 10000 @ 208V	VA
Maximum AC Power Output	3000	3800 @ 240V 3300 @ 208V	5000	6000 @ 240V 5000 @ 208V	7600	10000	11400 @ 240V 10000 @ 208V	VA
AC Output Voltage Min.-Nom.-Max. (211 - 240 - 264)	✓	✓	✓	✓	✓	✓	✓	Vac
AC Output Voltage Min.-Nom.-Max. (183 - 208 - 229)	-	✓	-	✓	-	-	✓	Vac
AC Frequency (Nominal)	59.3 - 60 - 60.5 <sup>(1)</sup>							Hz
Maximum Continuous Output Current @240V	12.5	16	21	25	32	42	47.5	A
Maximum Continuous Output Current @208V	-	16	-	24	-	-	48.5	A
Power Factor	1, adjustable -0.85 to 0.85							
GFDI Threshold	1							A
Utility Monitoring, Islanding Protection, Country Configurable Thresholds	Yes							
<b>INPUT</b>								
Maximum DC Power @240V	4650	5900	7750	9300	11800	15500	17650	W
Maximum DC Power @208V	-	5100	-	7750	-	-	15500	W
Transformer-less, Ungrounded	Yes							
Maximum Input Voltage	480							Vdc
Nominal DC Input Voltage	380				400			Vdc
Maximum Input Current @240V <sup>(2)</sup>	8.5	10.5	13.5	16.5	20	27	30.5	Adc
Maximum Input Current @208V <sup>(2)</sup>	-	9	-	13.5	-	-	27	Adc
Max. Input Short Circuit Current	45							Adc
Reverse-Polarity Protection	Yes							
Ground-Fault Isolation Detection	600k $\Omega$ Sensitivity							
Maximum Inverter Efficiency	99	99.2						%
CEC Weighted Efficiency	99						99 @ 240V 98.5 @ 208V	%
Nighttime Power Consumption	< 2.5							W

<sup>(1)</sup> For other regional settings please contact SolarEdge support

<sup>(2)</sup> A higher current source may be used; the inverter will limit its input current to the values stated

---

# Power Optimizer

For North America

P320 / P340 / P370 / P400 / P401 / P405 / P485 / P505

POWER OPTIMIZER



## PV power optimization at the module-level

- Specifically designed to work with SolarEdge inverters
- Up to 25% more energy
- Superior efficiency (99.5%)
- Mitigates all types of module mismatch losses, from manufacturing tolerance to partial shading
- Flexible system design for maximum space utilization
- Fast installation with a single bolt
- Next generation maintenance with module-level monitoring
- Meets NEC requirements for arc fault protection (AFCI) and Photovoltaic Rapid Shutdown System (PVRSS)
- Module-level voltage shutdown for installer and firefighter safety

# Power Optimizer For North America

P320 / P340 / P370 / P400 / P401 / P405 / P485 / P505

Optimizer model (typical module compatibility)	P320 (for 60-cell modules)	P340 (for high-power 60-cell modules)	P370 (for higher-power 60 and 72-cell modules)	P400 (for 72 & 96-cell modules)	P401 (for high power 60 and 72 cell modules)	P405 (for high-voltage modules)	P485 (for high-voltage modules)	P505 (for higher current modules)		
<b>INPUT</b>										
Rated Input DC Power <sup>(1)</sup>	320	340	370	400		405	485	505	W	
Absolute Maximum Input Voltage (Voc at lowest temperature)	48		60	80	60	125 <sup>(2)</sup>		83 <sup>(2)</sup>	Vdc	
MPPT Operating Range	8 - 48		8 - 60	8 - 80	8-60	12.5 - 105		12.5 - 83	Vdc	
Maximum Short Circuit Current (Isc)	11			10.1	11.75	11		14	Adc	
Maximum DC Input Current	13.75			12.5	14.65	12.5		17.5	Adc	
Maximum Efficiency	99.5								%	
Weighted Efficiency	98.8							98.6	%	
Overtoltage Category	II									
<b>OUTPUT DURING OPERATION (POWER OPTIMIZER CONNECTED TO OPERATING SOLAREEDGE INVERTER)</b>										
Maximum Output Current	15								Adc	
Maximum Output Voltage	60					85			Vdc	
<b>OUTPUT DURING STANDBY (POWER OPTIMIZER DISCONNECTED FROM SOLAREEDGE INVERTER OR SOLAREEDGE INVERTER OFF)</b>										
Safety Output Voltage per Power Optimizer	1 ± 0.1								Vdc	
<b>STANDARD COMPLIANCE</b>										
EMC	FCC Part15 Class B, IEC61000-6-2, IEC61000-6-3									
Safety	IEC62109-1 (class II safety), UL1741									
Material	UL94 V-0, UV Resistant									
RoHS	Yes									
<b>INSTALLATION SPECIFICATIONS</b>										
Maximum Allowed System Voltage	1000								Vdc	
Compatible inverters	All SolarEdge Single Phase and Three Phase inverters									
Dimensions (W x L x H)	129 x 153 x 27.5 / 5.1 x 6 x 1.1			129 x 153 x 33.5 / 5.1 x 6 x 1.3	129 x 153 x 29.5 / 5.1 x 6 x 1.16	129 x 159 x 49.5 / 5.1 x 6.3 x 1.9		129 x 162 x 59 / 5.1 x 6.4 x 2.3	mm / in	
Weight (including cables)	630 / 1.4			750 / 1.7	655 / 1.5	845 / 1.9		1064 / 2.3	gr / lb	
Input Connector	MC4 <sup>(3)</sup>						Single or dual MC4 <sup>(3)(4)</sup>	MC4 <sup>(3)</sup>		
Input Wire Length	0.16 / 0.52								m / ft	
Output Wire Type / Connector	Double Insulated / MC4									
Output Wire Length	0.9 / 2.95			1.2 / 3.9						m / ft
Operating Temperature Range <sup>(5)</sup>	-40 - +85 / -40 - +185								°C / °F	
Protection Rating	IP68 / NEMA6P									
Relative Humidity	0 - 100								%	

(1) Rated power of the module at STC will not exceed the optimizer "Rated Input DC Power". Modules with up to +5% power tolerance are allowed

(2) NEC 2017 requires max input voltage be not more than 80V

(3) For other connector types please contact SolarEdge

(4) For dual version for parallel connection of two modules use P485-4NMDMRM. In the case of an odd number of PV modules in one string, installing one P485 dual version power optimizer connected to one PV module. When connecting a single module seal the unused input connectors with the supplied pair of seals.

(5) For ambient temperature above +85°C / +185°F power de-rating is applied. Refer to Power Optimizers Temperature De-Rating Technical Note for more details.

PV System Design Using a SolarEdge Inverter <sup>(6)(7)</sup>	Single Phase HD-Wave	Single phase	Three Phase for 208V grid	Three Phase for 277/480V grid	
Minimum String Length (Power Optimizers)	P320, P340, P370, P400, P401	8	10	18	
	P405, P485, P505	6	8	14	
Maximum String Length (Power Optimizers)		25	25	50 <sup>(8)</sup>	
Maximum Power per String	5700 (6000 with SE7600-US - SE11400-US)	5250	6000 <sup>(9)</sup>	12750 <sup>(10)</sup>	W
Parallel Strings of Different Lengths or Orientations	Yes				

(6) For detailed string sizing information refer to: [http://www.solaredge.com/sites/default/files/string\\_sizing\\_na.pdf](http://www.solaredge.com/sites/default/files/string_sizing_na.pdf)

(7) It is not allowed to mix P405/P485/P505 with P320/P340/P370/P400/P401 in one string

(8) A string with more than 30 optimizers does not meet NEC rapid shutdown requirements; safety voltage will be above the 30V requirement

(9) For 208V grid: it is allowed to install up to 6,500W per string when the maximum power difference between each string is 1,000W

(10) For 277/480V grid: it is allowed to install up to 15,000W per string when the maximum power difference between each string is 2,000W



## Application Note - SolarEdge String Sizing, North America

### Introduction

There are two primary criteria for string sizing in a SolarEdge system. Maximum (STC) power per string, and minimum and maximum string lengths. This document explains how these values are determined and provides the string sizing rules for the different inverter and optimizer combinations. For additional system design information refer to the inverter and optimizer datasheets.

Sizing rules typically depend on the type of inverters and optimizers used:

- Inverters: single phase or three phase
- Optimizers: general or commercial

Commercial optimizers can be used only with three phase inverters, while general optimizers can be used with both single and three phase inverters.

General optimizers typically have one PV module per optimizer, and commercial optimizers typically have two modules. However these are not fixed requirements and as long as the cumulative power and voltage/current of the modules meets the optimizer specifications as detailed in the datasheet, connecting additional modules per optimizer is permitted (for example connecting 2x120W modules in series to a single P300 general optimizer). Refer to the Connecting Multiple Modules to Power Optimizers [application note](#) for details.

#### NOTE

In the context of this document, string length refers to the number of optimizers and modules in the string. When designing the installation make sure to maintain the maximum **physical** string length as well: The total cable length of the string (excluding power optimizers' conductors) should not exceed 1000ft./300m from DC+ to DC- of the inverter (2,300ft./700m when using the SE14.4KUS and SE33.3KUS inverters).

### Maximum String Power

Maximum string power is simply the "Inverter Nominal DC Input Voltage" multiplied by the "Optimizer Maximum Output Current". These values can be found on the inverter and optimizer datasheets respectively. Table 1 details the values of available products.

Inverter Model	AC Grid Voltage [V]	Inverter Nominal DC Input Voltage [V]	Optimizer Max Output Current [A]	Maximum String Power [Wp]
Single phase inverters SE3000A-US – SE11400A-US	240	350	15	5,250
Single phase HD-Wave Inverters SE3000H-US – SE6000H-US	240	380	15	5,700
Single phase HD-Wave Inverter SE7600H-US	240	400	15	6000
SE9KUS, SE14.4KUS	120/208	400	15	6000 (or 6500 in some cases <sup>1</sup> )
			18 (P800)	7200
SE10KUS, SE20KUS, SE33.3KUS	277/480	850	15	12750 (or 15000 in some cases <sup>2</sup> )
			18 (P800)	15300

Table 1: Maximum string power

<sup>1</sup> For SE14.4KUS only, when used with P600/P700/P730, it is allowed to install up to 6500W per string when 3 strings are connected to the inverter and when the maximum power difference between the strings is up to 1000W.

<sup>2</sup> For SE33.3KUS only, when used with P600/P700/P730, it is allowed to install up to 15000W per string when 3 strings are connected to the inverter and when the maximum power difference between the strings is up to 2000W.

### Minimum and Maximum String Length

The minimum number of optimizers per string depends on the "Maximum Output Voltage" of the optimizer and on the "Nominal DC Input Voltage" of the inverter: the optimizers connected in series in the string must be able to achieve the inverter's nominal voltage. There is a buffer added to ensure the operability of the string also in some shading or fault conditions.

The maximum number of optimizers per string was established to ensure proper communications between the optimizers and inverter.

#### NOTE

When connecting multiple modules to commercial optimizers, in case of an odd number of modules per string it is allowed to connect one optimizer with one module, as long the minimum number of modules per string is maintained as well.

		General optimizers	Commercial optimizers
Single phase inverters	Minimum	8	N/A
	Maximum	25	N/A
SE9KUS, SE14.4KUS	Minimum	10	8 optimizers, 16 modules
	Maximum	25	30 optimizers
SE10KUS, SE20KUS, SE33.3KUS	Minimum	18	13 optimizers, 26 modules
	Maximum	50	30 optimizers

Table 2: Minimum and maximum string length

## Rapid Shutdown Kit - Installation and Configuration (Single Phase Inverters)

This document describes how to install the rapid shutdown kit in the SolarEdge Safety Switch, and how to enable the rapid shutdown feature in the inverter in order to provide the functionality described in the Rapid Shutdown clause of NEC2014 690.12 (1) through (4).

### Kit Contents

- Rapid shutdown cables
- Micro-SD card and SD card adapter with firmware files (Note: DO NOT THROW AWAY THE CARD AND THE ADAPTER; keep them for installation of other rapid shutdown kits)

### Cable Installation

Perform this procedure before connecting the strings to the Safety Switch [Chapter 4: Connecting the AC and the Strings to the Safety Switch in the *SolarEdge Installation Guide*].

- 1 Turn the inverter ON/OFF switch to OFF. If installing the kit in an inverter that is already operating, wait until the LCD indicates that the DC voltage is safe (<50V), or wait five minutes before continuing to the next step.
- 2 Turn the Safety Switch and the AC switch on the main circuit board to OFF.



#### WARNING!

If you cannot see the inverter panel, or if a malfunction is indicated on the LCD panel, wait five minutes for the input capacitors of the inverter to discharge.

- 3 Loosen the four Allen screws on the front cover of the Safety Switch, and open the cover.
- 4 Carefully disconnect the two DC cables from the left side of the switch and from the DC connection spring clamp terminals, as illustrated below<sup>1</sup>. Use a standard straight-bladed screwdriver to disconnect the cables from the terminals.

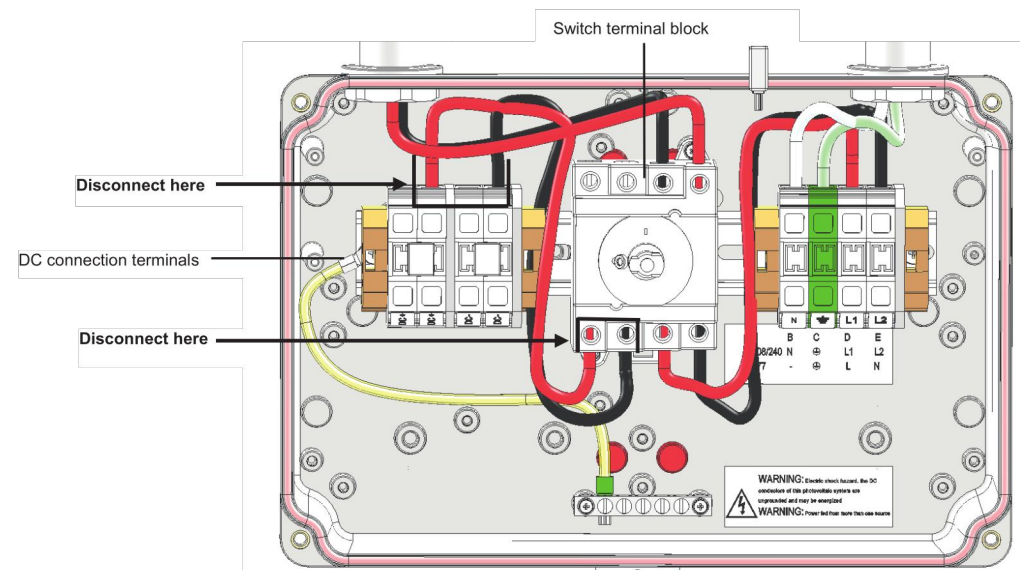

Figure 1: Inside the AC/DC Safety Switch

<sup>1</sup> The internal components may vary depending on the Safety Switch model; the figures in this documents show the AC/DC Safety Switch for single phase 7.6-11.4 kW inverters.

- 5 The rapid shutdown cables have a resistor connected to one end (on the red cable). Connect these ends to the switch, making sure that the red and black cables are reversed relative to the cables connected at the top of the switch (going into the DC side conduit between the inverter and the Safety Switch), as detailed below. Apply a torque of 2 N\*m (18 lb\*in):
  - If the cables at the top are red and black from left to right, connect as shown below.

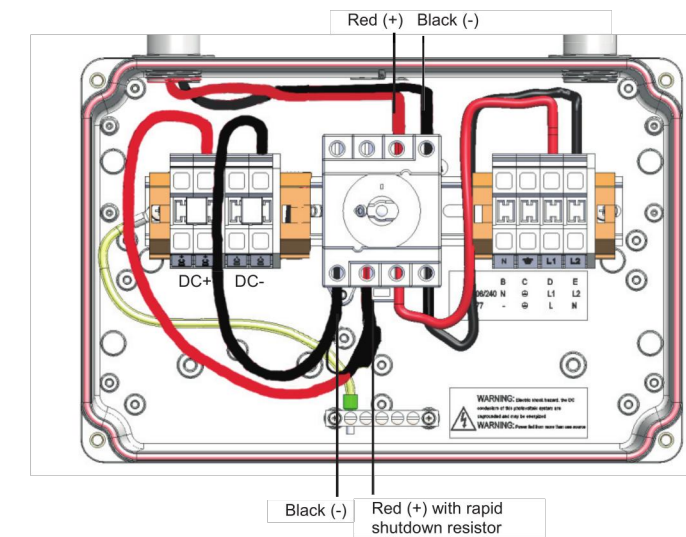

Figure 2: Rapid shutdown cable connected – option 1

- If the cables at the top are black and red from left to right, connect as shown below.

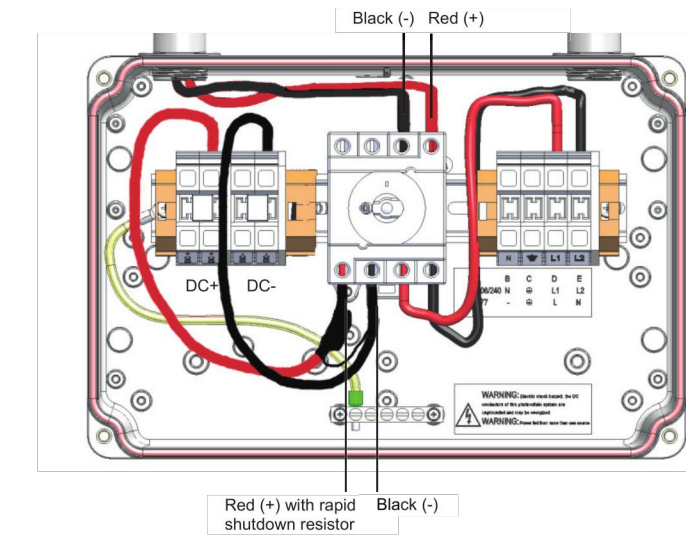

Figure 3: Rapid shutdown cable connected – option 2

- 6 Use a standard straight-bladed screwdriver to connect the other end of the rapid shutdown cables to the DC connection spring-clamp terminals: Connect the black cable from the switch to the DC- terminal block, and connect the red cable from the switch to the DC+ terminal block.
- 7 Check that the cables are located and connected in the correct positions to ensure the rapid shutdown functionality.
- 8 Close the cover: Attach the switch cover and secure it by tightening the four screws with a torque of 0.9 ft.\*lb / 1.2 N\*m.





# Integrated Grounding System

## Simplified Grounding For Greater Safety & Lower Cost

Traditionally, solar modules are grounded by attaching lugs, bolts or clips to the module frame, then connecting these to a copper conductor that runs throughout the array. This process adds time and cost to the installation, and often results in improper grounding, creating significant long-term safety risks.

The IronRidge Integrated Grounding System solves these challenges by bonding modules directly to the mounting rails. This approach eliminates separate module grounding hardware, and it creates many parallel grounding paths throughout the array, providing greater safety for system owners.

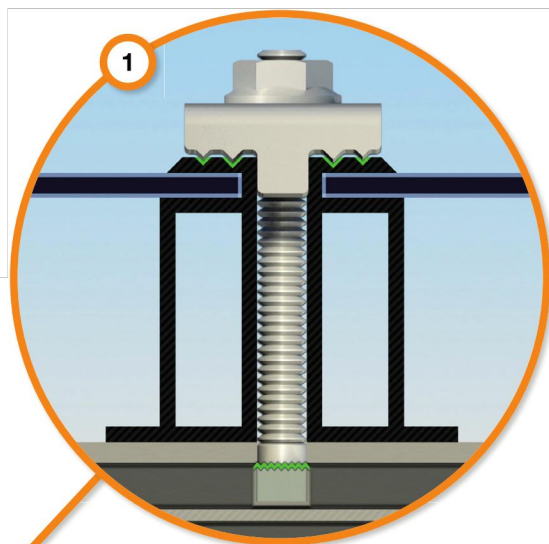

### Grounding Mid Clamp

Each Grounding Mid Clamp pierces through the anodized coatings of both the module frame and the mounting rail to form secure electrical bonds, which are repeated throughout the array.

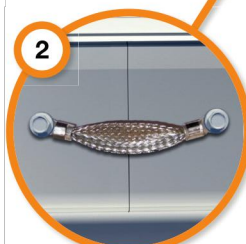
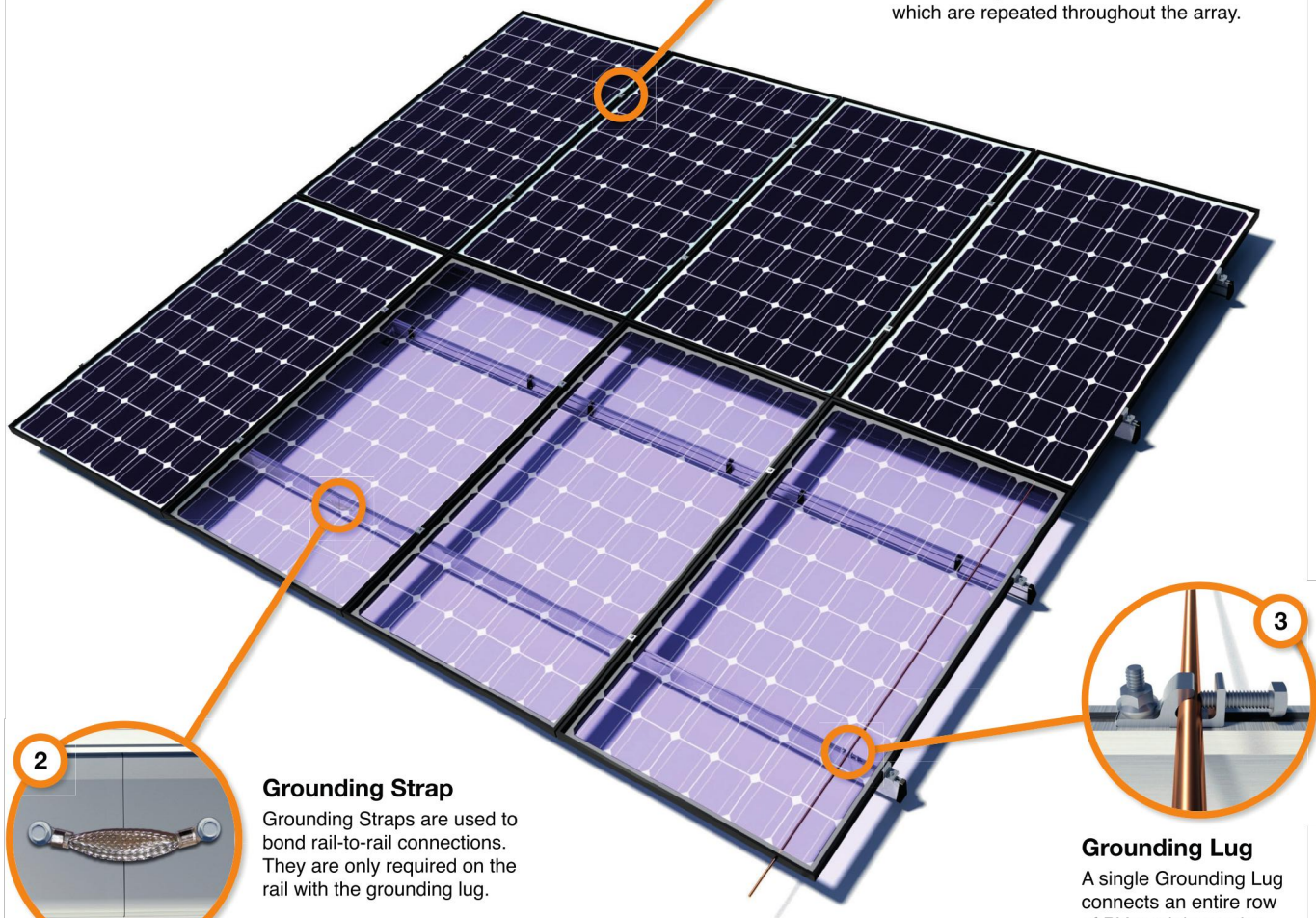

### Grounding Strap

Grounding Straps are used to bond rail-to-rail connections. They are only required on the rail with the grounding lug.

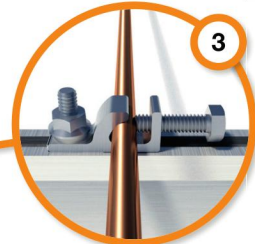

### Grounding Lug

A single Grounding Lug connects an entire row of PV modules to the grounding conductor.

## Installation Overview

- 1 Install Roof Attachments**
  - Install appropriate roof flashing and/or standoff for roof type.
  - Attach L-Feet to flashing or standoff.
- 2 Prepare Rail Connections**
  - Insert splice into first rail, then secure with Grounding Strap and self-drilling screw.
  - Slide second rail over splice, then secure with opposite end of Grounding Strap and self-drilling screw.
- 3 Mount & Ground Rails**
  - Attach rails to L-Feet and level rails.
  - Install one Grounding Lug per row of modules.
  - Connect Grounding Lug to grounding conductor.
- 4 Install Modules & Clamps**
  - Install first module using End Clamps and Grounding Mid Clamps.
  - Install additional modules using Grounding Mid Clamps.
  - Finish row with a second pair of End Clamps.

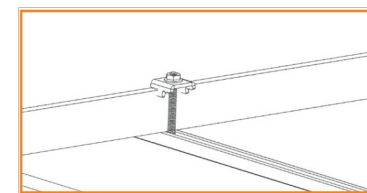
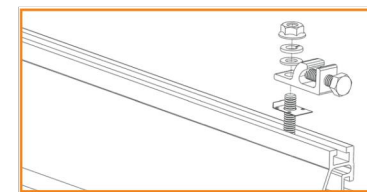
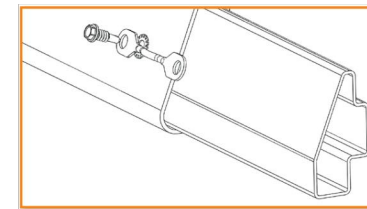
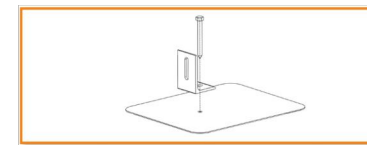

## Testing & Certification

The IronRidge Integrated Grounding System has been tested and certified to UL 2703 by Intertek Group plc.

UL 2703 is a proposed UL standard for evaluating solar module mounting and clamping devices. It ensures these devices will maintain strong electrical and mechanical connections over an extended period of time in extreme outdoor environments.

The testing process closely mirrors that of UL 1703, the solar module testing standard, including temperature and humidity cycling, electrical and mechanical load testing, and manufacturing quality reviews.

### Module Frame Compatibility

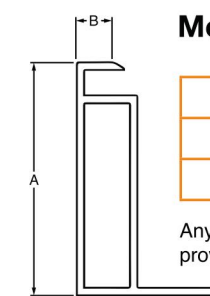

Dimension	Range
A	31.0mm - 51.0mm
B	5.08mm (minimum)

Any module frames whose parameters are not listed in the provided table have not been tested for compatibility.

The Grounding Clamp has proven robust in grounding 60-cell and 72-cell solar module frames with box construction and a range of anodization thicknesses.

All solar modules listed to UL 1703 and with frame construction within the parameters stated above are compatible with the IronRidge Integrated Grounding System.

[Go to ironridge.com/ig](http://ironridge.com/ig)





# FlashFoot2

## The Strongest Attachment in Solar

IronRidge FlashFoot2 raises the bar in solar roof protection. The unique water seal design is both elevated and encapsulated, delivering redundant layers of protection against water intrusion. In addition, the twist-on Cap perfectly aligns the rail attachment with the lag bolt to maximize mechanical strength.

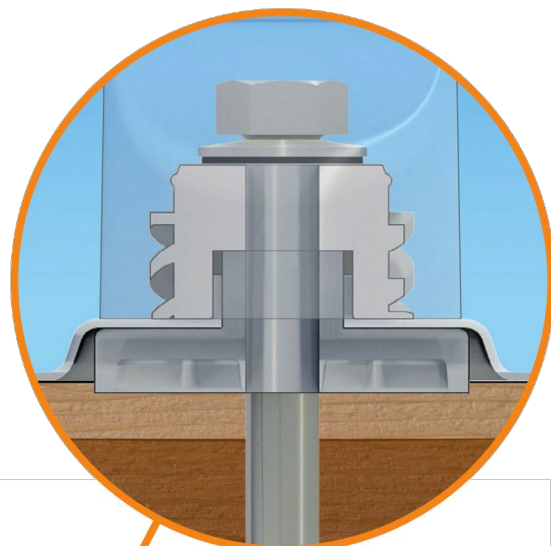

### Twist-On Cap

FlashFoot2's unique Cap design encapsulates the lag bolt and locks into place with a simple twist. The Cap helps FlashFoot2 deliver superior structural strength, by aligning the rail and lag bolt in a concentric load path.



### Three-Tier Water Seal

FlashFoot2's seal architecture utilizes three layers of protection. An elevated platform diverts water away, while a stack of rugged components raises the seal an entire inch. The seal is then fully-encapsulated by the Cap. FlashFoot2 is the first solar attachment to pass the TAS-100 Wind-Driven Rain Test.

### Single Socket Size

A custom-design lag bolt allows you to install FlashFoot2 with the same 7/16" socket size used on other Flush Mount System components.

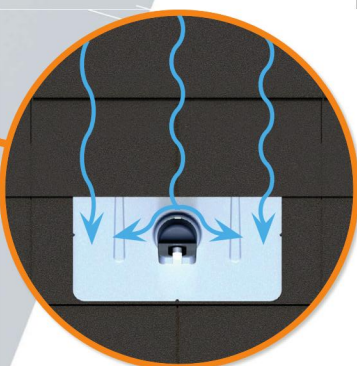

### Water-Shedding Design

An elevated platform diverts water away from the water seal.

## Installation Features

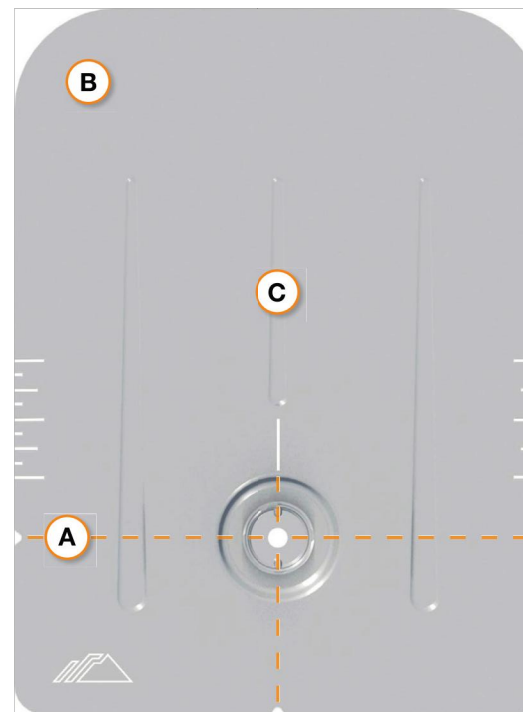

### A Alignment Markers

Quickly align the flashing with chalk lines to find pilot holes.

### B Rounded Corners

Makes it easier to handle and insert under the roof shingles.

### C Reinforcement Ribs

Help to stiffen the flashing and prevent any bending or crinkling during installation.

## Benefits of Concentric Loading

Traditional solar attachments have a horizontal offset between the rail and lag bolt, which introduces leverage on the lag bolt and decreases uplift capacity.

FlashFoot2 is the only product to align the rail and lag bolt. This concentric loading design results in a stronger attachment for the system.

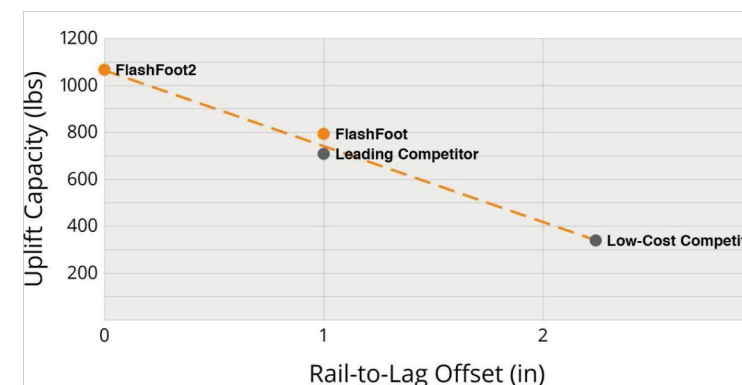

## Testing & Certification

### Structural Certification

Designed and Certified for Compliance with the International Building Code & ASCE/SEI-7.

### Water Seal Ratings

Water Sealing Tested to UL 441 Section 27 "Rain Test" and TAS 100-95 "Wind Driven Rain Test" by Intertek. Ratings applicable for composition shingle roofs having slopes between 2:12 and 12:12.

### UL 2703

Conforms to UL 2703 Mechanical and Bonding Requirements. See Flush Mount Install Manual for full ratings.





# XR Rail Family

## Solar Is Not Always Sunny

Over their lifetime, solar panels experience countless extreme weather events. Not just the worst storms in years, but the worst storms in 40 years. High winds capable of ripping panels from a roof, and snowfalls weighing enough to buckle a panel frame.

XR Rails are the structural backbone preventing these results. They resist uplift, protect against buckling and safely and efficiently transfer loads into the building structure. Their superior spanning capability requires fewer roof attachments, reducing the number of roof penetrations and the amount of installation time.

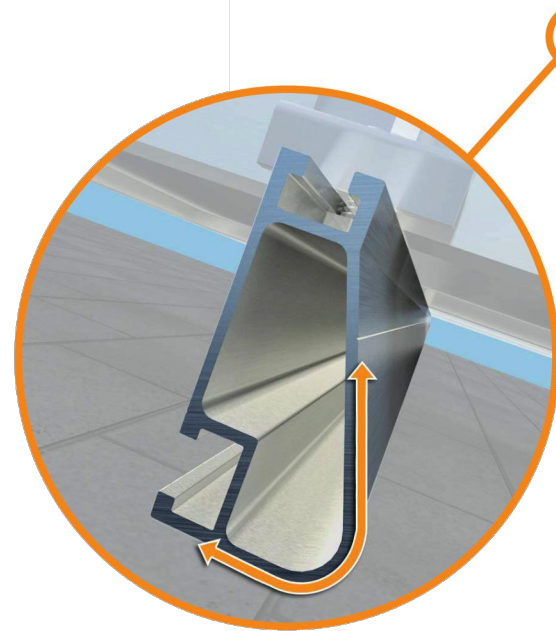
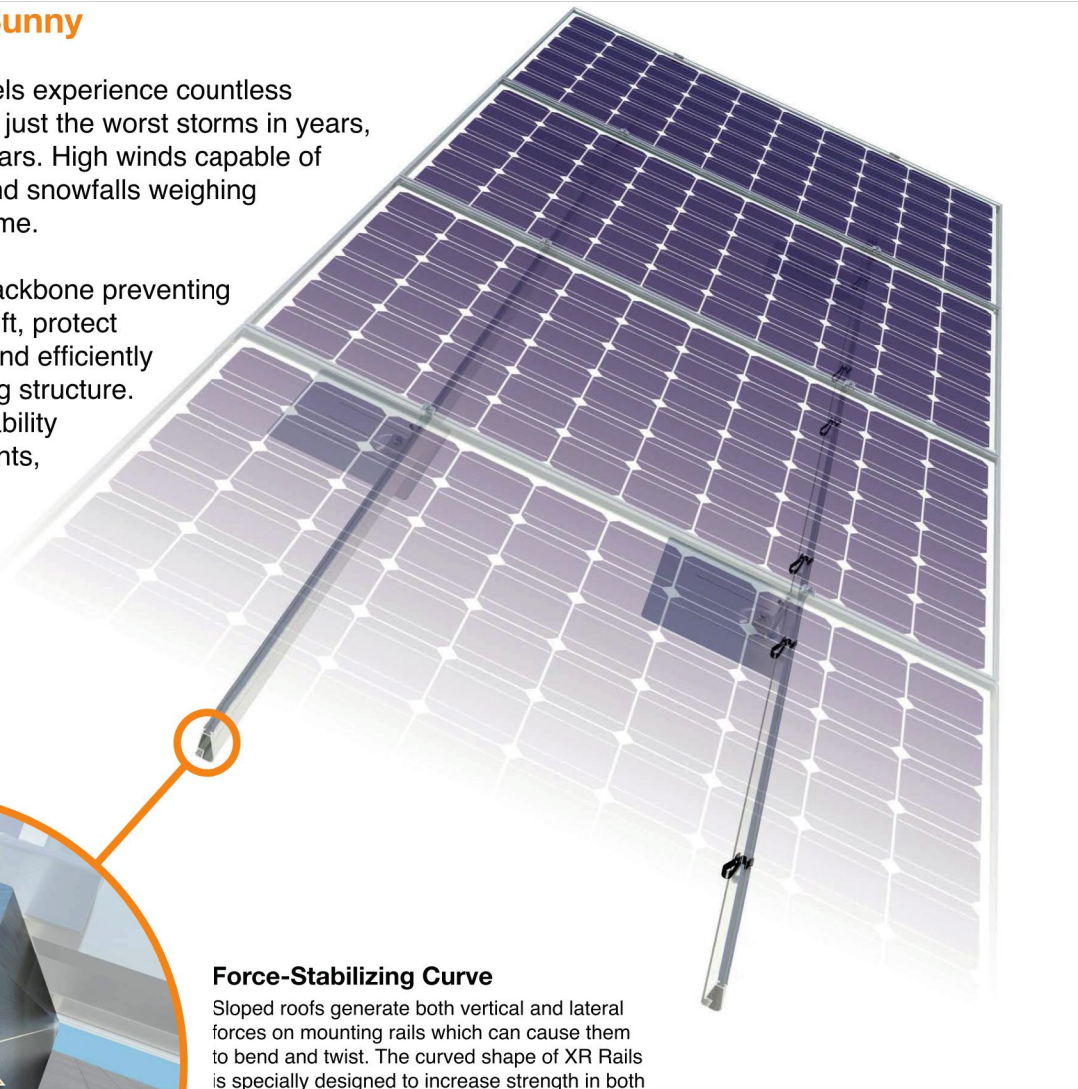

### Force-Stabilizing Curve

Sloped roofs generate both vertical and lateral forces on mounting rails which can cause them to bend and twist. The curved shape of XR Rails is specially designed to increase strength in both directions while resisting the twisting. This unique feature ensures greater security during extreme weather and a longer system lifetime.



# XR10 Rail

See Description / Length

Rail Section Properties	
Property	Value
Total Cross-Sectional Area	0.363 in <sup>2</sup>
Section Modulus (X-axis)	0.136 in <sup>3</sup>
Moment of Inertia (X-axis)	0.124 in <sup>4</sup>
Moment of Inertia (Y-axis)	0.032 in <sup>4</sup>
Torsional Constant	0.076 in <sup>3</sup>
Polar Moment of Inertia	0.033 in <sup>4</sup>

Clear Part Number	Black Part Number	Description / Length	Material	Weight
XR-10-132A	XR-10-132B	XR10, Rail 132" (11 Feet)	6000-Series Aluminum	4.67 lbs.
XR-10-168A	XR-10-168B	XR10, Rail 168" (14 Feet)		5.95 lbs.
XR-10-204A	XR-10-204B	XR10, Rail 204" (17 Feet)		7.22 lbs.

v1.0

### Compatible with Flat & Pitched Roofs

XR Rails are compatible with FlashFoot and other pitched roof attachments.

IronRidge offers a range of tilt leg options for flat roof mounting applications.

### Corrosion-Resistant Materials

All XR Rails are made of marine-grade aluminum alloy, then protected with an anodized finish. Anodizing prevents surface and structural corrosion, while also providing a more attractive appearance.

# Flush Mount System

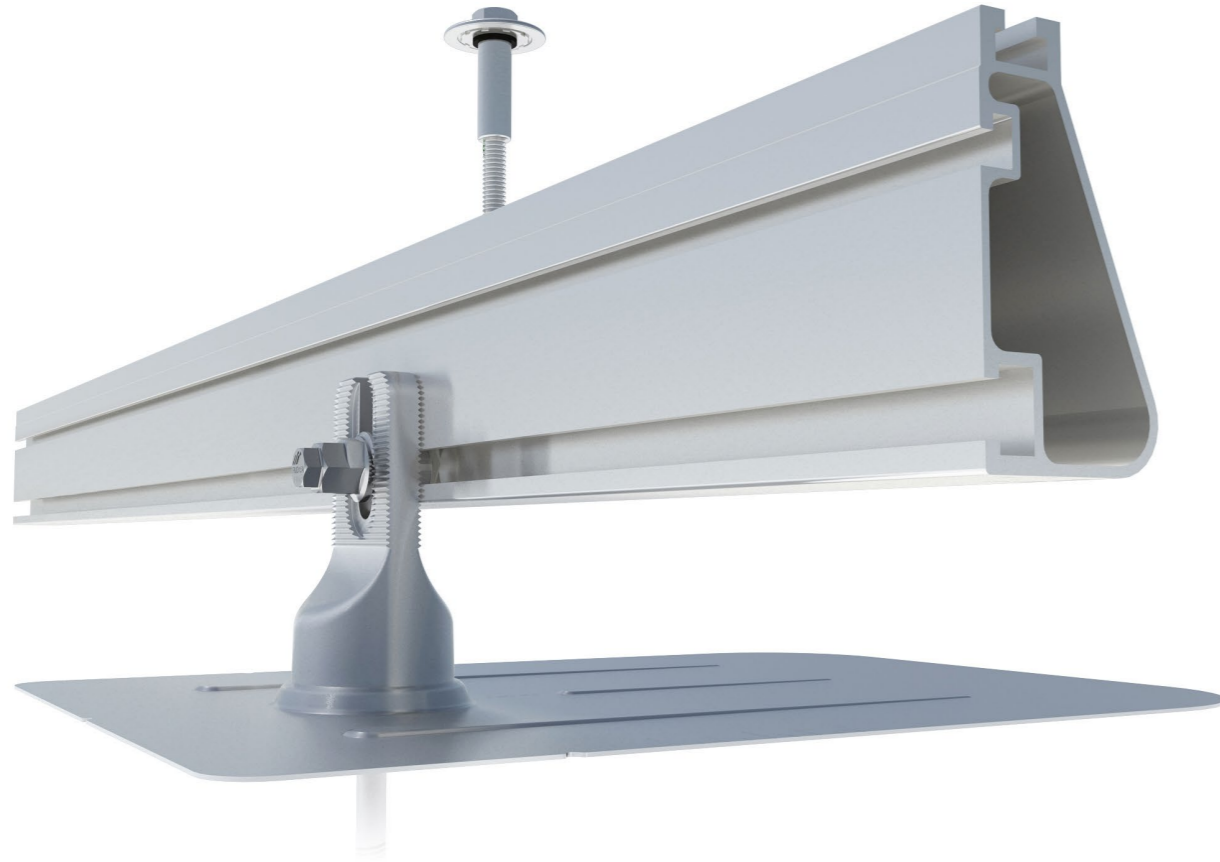

## Built for solar's toughest roofs.

IronRidge builds the strongest mounting system for pitched roofs in solar. Every component has been tested to the limit and proven in extreme environments.

Our rigorous approach has led to unique structural features, such as curved rails and reinforced flashings, and is also why our products are fully certified, code compliant and backed by a 20-year warranty.



### Strength Tested

All components evaluated for superior structural performance.



### Class A Fire Rating

Certified to maintain the fire resistance rating of the existing roof.



### UL 2703 Listed System

Entire system and components meet newest effective UL 2703 standard.



### PE Certified

Pre-stamped engineering letters available in most states.



### Design Assistant

Online software makes it simple to create, share, and price projects.



### 20-Year Warranty

Twice the protection offered by competitors.

## XR Rails ☺

### XR10 Rail



A low-profile mounting rail for regions with light snow.

- 6' spanning capability
- Moderate load capability
- Clear & black anod. finish

### XR100 Rail



The ultimate residential solar mounting rail.

- 8' spanning capability
- Heavy load capability
- Clear & black anod. finish

### XR1000 Rail



A heavyweight mounting rail for commercial projects.

- 12' spanning capability
- Extreme load capability
- Clear anodized finish

### Bonded Splices



All rails use internal splices for seamless connections.

- Self-drilling screws
- Varying versions for rails
- Forms secure bonding

## Clamps & Grounding ☺

### UFOs



Universal Fastening Objects bond modules to rails.

- Fully assembled & lubed
- Single, universal size
- Clear & black finish

### Stopper Sleeves



Snap onto the UFO to turn into a bonded end clamp.

- Bonds modules to rails
- 6 different sizes
- Clear & black anod. finish

### Grounding Lugs



Connect arrays to equipment ground.

- Low profile
- Single tool installation
- Mounts in any direction

### Microinverter Kits

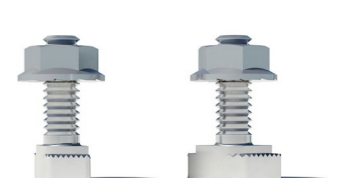

Mount MIs or POs to XR Rails.

- Bonds devices to rails
- Kit comes assembled
- Listed to UL 2703

## Attachments ☺

### FlashFoot2



Flash and mount XR Rails with superior waterproofing.

- Twist-on Cap eases install
- Wind-driven rain tested
- Mill & black finish

### Slotted L-Feet



Drop-in design for rapid rail attachment.

- Secure rail connections
- Slot for vertical adjusting
- Clear & black anod. finish

### Bonding Hardware

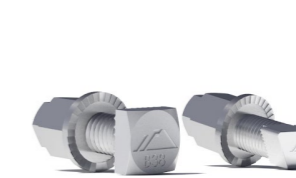

Bond and attach XR Rails to certified attachments.

- T & Square Bolt options
- Nut uses 7/16" socket
- Assembled & lubricated

### Flush Standoffs



Raise Flush Mount System to various heights.

- Works with vent flashing
- 4" and 7" lengths
- Ships assembled

## Resources



### Design Assistant

Go from rough layout to fully engineered system. For free.

[Go to IronRidge.com/design](http://IronRidge.com/design)



### NABCEP Certified Training

Earn free continuing education credits, while learning more about our systems.

[Go to IronRidge.com/training](http://IronRidge.com/training)



# SolaDeck

FLASHED PV ROOF-MOUNT COMBINER/ENCLOSURE

## Basic Features

- Stamped Seamless Construction
- 18 Gauge Galvanized Steel
- Powder Coated Surfaces
- Flashes into the roof deck
- 3 Roof deck knockouts .5", .75", 1"
- 5 Centering dimples for entry/exit fittings or conduit
- 2 Position Ground lug installed
- Mounting Hardware Included



SolaDeck Model SD 0783



## SolaDeck UL50 Type 3R Enclosures

Available Models:

Model SD 0783 - (3" fixed Din Rail)

Model SD 0786 - (6" slotted Din Rail)



## SolaDeck UL 1741 Combiner/Enclosures

Models SD 0783-41 and SD 0786-41 are labeled and ETL listed UL STD 1741 according to the UL STD 1741 for photovoltaic combiner enclosures.

Max Rated - 600VDC, 120AMPS

**Model SD 0783-41** 3" Fixed Din Rail fastened using Norlock System

### \*\*Typical System Configuration

- 4- Din Rail Mounted Fuse Holders 600VDC 30 AMP
- 1- Power Distribution Block 600VDC 175AMP
- 1- Bus Bar with UL lug

**Model SD 0786-41** 6" Slotted Din Rail fastened using steel studs

### \*\*Typical System Configuration

- 4- Din Rail Mounted Fuse Holders 600VDC 30 AMP
- 4- Din Rail Mounted Terminal Blocks
- Bus Bars with UL lug

\*\*Fuse holders and terminal blocks added in the field must be UL listed or recognized and meet 600 VDC 30 AMP 110C for fuse holders, 600V 50 AMP 90C for rail mounted terminal blocks and 600 V 175 AMP 90C for Power Distribution Blocks. Use Copper Wire Conductors.



Cover is trimmed to allow conduit or fittings, base is center dimpled for fitting locations.



Model SD 0783-41, wired with Din Rail mounted fuse holders, bus bar and power distribution block.



Model SD 0786-41, wired with Din Rail mounted fuse holders, terminal blocks and bus bars.