

EGGKITPO

DESIGNED AND MANUFACTURED FOR COMMERCIAL KITCHENS

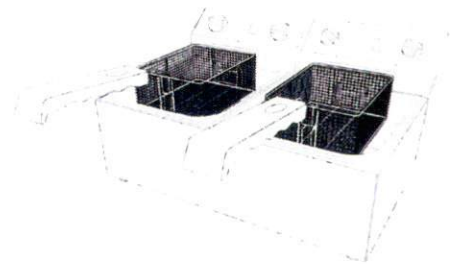
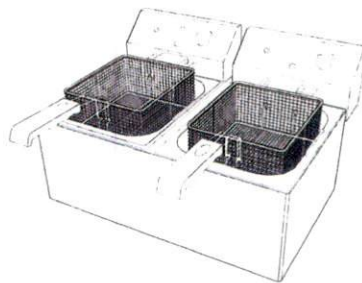
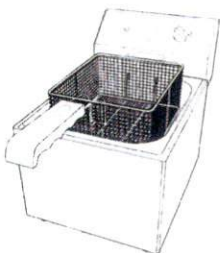
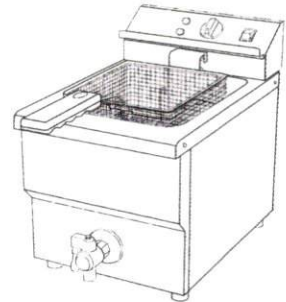
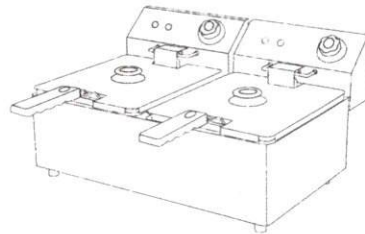
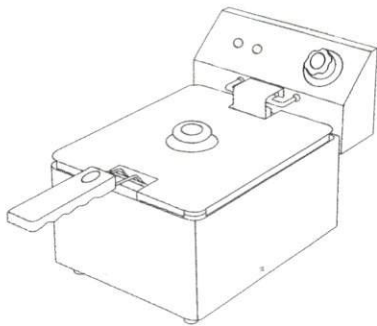

EGGKITPO Commercial Deep Fryer

Model :	EGEF-10L	EGEF-10L-2
	EGEF-12L	EGEF-12L-2
	EGEF-101V	EGEF-101V-2
	EGEF-12V	EGEF-12V-2



Please carefully read this manual before using this product. Please pay extra attention to those wording in "RED" and "Bold Black".

Make sure you are familiar with all of the safety and usage instructions.

Keep this manual in a safe place for future reference.



SAFETY INFORMATION



WARNING: The installation, maintenance and servicing of this product must be carried out by a qualified technician.

You should consult local and national standards to comply with the following:

- Health & safety at work legislation
- Fire precautions
- IEE Wiring regulations
- Building regulations

WARNING: Incorrect installation, unauthorized modifications, refitting, adjustments, dismantling or maintenance could result in damage to the product, damage to property or serious injury.

All repairs, maintenance and adjustments must be carried out by a qualified technician.

WARNING: RISK OF SEVERE BURNS. Take caution when using this product.

WARNING: RISK OF ELECTRIC SHOCK. DO NOT use when the power cord is damaged.

WARNING: For safety reasons, this product **MUST** be earthed.

WARNING: RISK OF FIRE. Do not operate the product with oil level below the minimum indicated.

WARNING: RISK OF FIRE. Position the fryer away from surfaces or areas that may exceed 300°C. Hot oil splashing onto hot surfaces will cause fire.

WARNING: This is a commercial product and must only be used by a trained operative who has read and fully understands this manual. It must not be used by children or persons with reduced physical, sensory or mental capabilities. Before using the product, ensure the ratings marked on the product conforms to the electricity supply. Check power cord for damage prior to every use. If damaged it can only be replaced by the manufacturer or a qualified technician.

IMPORTANT: The product should be given a visual safety check over every day to help prevent accidents.

IMPORTANT: The product should not be used if operator feels there is anything wrong with it. The problem should be referred to the manufacturer or a qualified technician. Incorrect use of the product, other than its intended use, can cause damage to it and be dangerous. The product surfaces and control panel may be damaged by hard or sharp objects.

DO NOT use a power supply that is not compatible with safety standards.

DO NOT store any type of flammable liquid, gas or other similar items near or around this product.

DO NOT knock or bump the product or place objects on top of it.

DO NOT operate or disconnect this product with wet hands.

DO NOT ever handle or move the product when it contains hot oil.

CAUTION: Be aware that surfaces of the product may be hot before and after the product has been used - **RISK OF SEVERE BURNS.**

DO NOT use the product during a thunderstorm. To avoid the product being damaged by a lightning strike, unplug removing it from electricity supply prior to the storm. Allow the product to cool before cleaning. Before cleaning, unplug the product from the mains power supply.

DO NOT spray or splash water directly onto the product - **RISK OF ELECTRIC SHOCK.**

DO NOT submerge product, electric plug or power lead in water or other liquids.

DO NOT use old oil, this will have a reduced flash point and be more prone to surge boiling.

DO NOT use a water jet to clean this product.

DO NOT use wet cloths, steel wool pads or abrasive creams to clean the product plates, surface of the product or power cord. When not in use, turn the temperature control to the 'MIN' position and unplug the product from the mains power supply. Store product in a safe, clean, dry, well ventilated place if it is not going to be used for any length of time.

EXTREME CAUTION: Failure to follow instructions could result in damage to product, damage to property or serious injury. To avoid risk of suffocation to children or animals, dispose of the plastic bags and packaging correctly.

For use with an earthed wall socket. For indoor use only. Must **NOT** be used outdoors. Not suitable for use with an extension cable.

Keep product and power cord out of reach of children and keep pets clear during use.

DO NOT position or use product underneath or near flammable items such as curtains, shelves, cupboards etc - FIRE HAZARD

DO NOT cover the product with anything - FIRE HAZARD

DO NOT allow the power cord to hang over the edge of a table or work surface on which the product stands.

DO NOT allow the power cord to come into contact with a heat source.

DO NOT use on or near direct heat sources.

DO NOT operate product if cracked, or the power cord, plug or it is damaged in any way.

DO NOT leave product unattended when in use.

DO NOT attempt to service the product yourself. Contact qualified technician.

CAUTION: Do not pull or drag the product by the power cord. The product must be placed and operated on a safe, flat and stable surface.

Children should be supervised to ensure that they do not play with the appliance.

Introduction of the EGGKITPO ELECTRIC DEEP FRYERS

Thank you for purchasing this Electric Fryer. It's perfect for cooking, frying and warming food. Each model features easy to use controls and fast heat up elements.

For extra total operator safety, All EGGKITPO Fryers are equipped with a micro-switch that deactivates the whole unit when the Fryer head is removed. Always place the fryer head firmly in the right place and make sure that the micro-switch (located on the bottom of the fryer head) is in touch with the main body.

In addition to that, All EGGKITPO deep fryers has a built-in thermal cut-off device that will shut-off the fryers automatically to avoid overheating. Manual reset please refer to troubleshooting "Temperature safety reset switch".

NOTES ON THE PLUG

This appliance has a grounded 3-prong plug. Connect to a properly grounded outlet only. If the plug does not fit fully into the outlet, contact a qualified electrician. Do not attempt to modify the plug in any way.



EF-10L, EF-10L-2, EF-101V, EF-101V-2

– 120V 1800W; NEMA 5-15 PLUG ETLus, need 5-15R Receptacles

Accordingly, dual units need two 5-15R receptacles

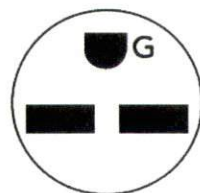

EF-12L, EF-12L-2, EF-12V, EF-12V-2

– 240V 3300W; NEMA 6-15 PLUG ETLus, need 6-15R Receptacles

accordingly, dual units need two 6-15R Receptacles

NOTES ON THE CORD

A short power supply cord has been provided to reduce the hazards resulting from becoming entangled in or tripping over a longer cord. An extension cord may be used with this appliance if care is properly exercised in its use. If an extension cord is used, the marked electrical rating of the extension cord must be at least as great as the electrical rating on this appliance. The longer cord should be arranged so that it will not drape over the counter top or table top where it can be pulled on by children or another person or tripped over accidentally.

ELECTRIC POWER

If the electrical circuit is overloaded with other appliances, your appliance may not operate properly. It should be operated on a separate electrical circuit from other appliances.

Features and Controls

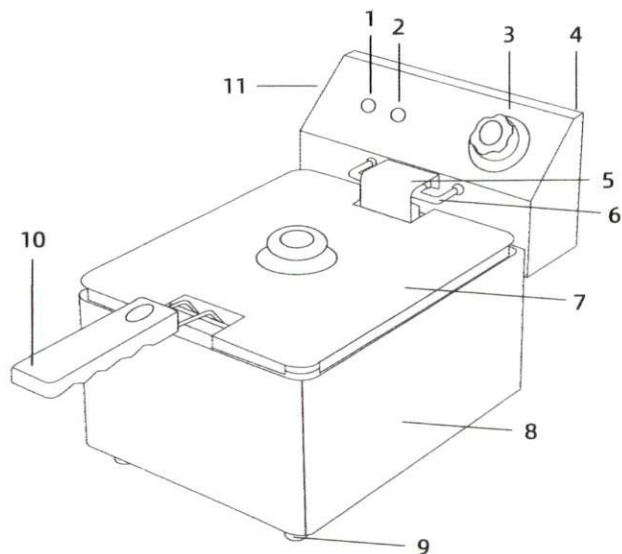

Electric Fryer Parts EGEF-10L:

1. Power indicator (green)
2. Thermostat indicator (yellow)
3. Temperature control knob
4. Reset button - located on back of machine
5. Heating element cover
6. **Basket hook**
7. **Night cover**
8. Main housing
9. **Rubber feet**
10. **Basket handle(basket not shown)**

Note: The Double Fryer has 2 plugs, one plug supplying power to each side.

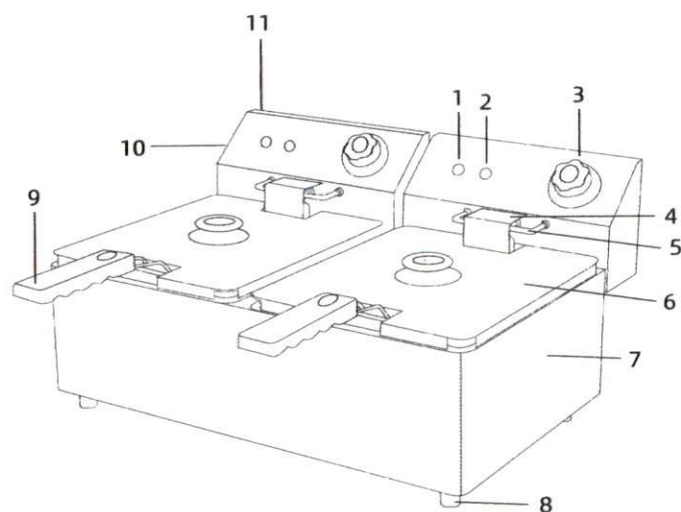

Electric Fryer Parts EGEF-10L-2:

1. Power indicator (green)
2. Thermostat indicator (yellow)
3. Temperature control knob
4. Heating element cover
5. Basket hook
6. **Night cover**
7. **Main housing**
8. **Rubber feet**
9. **Basket handle(basket not shown)**
10. **Reset button - located on back of machine**

Note: The Dual Fryer has 2 plugs, one plug supplying power to each side.

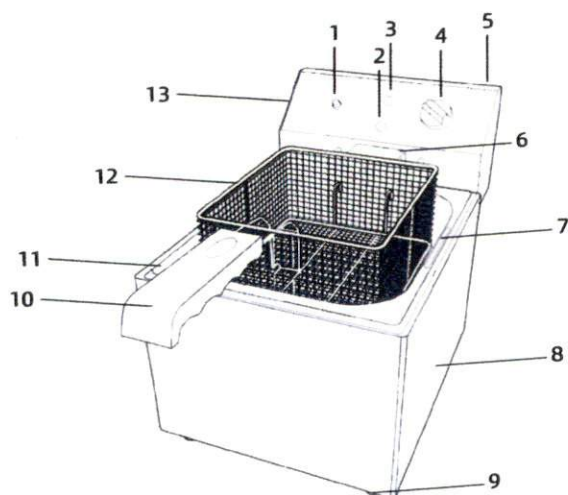

Electric Fryer Parts EGEF-12L:

1. **Reset button**
2. Thermostat indicator (yellow)
3. Power indicator (green)
4. Temperature control knob
5. **Micro switch**
6. **Heating element cover**
7. **Oil tank handle**
8. **Main housing**
9. **Rubber feet**
10. **Basket handle**
11. **Oil tank**
12. **basket**
13. **Night cover-located on top of the fryer when not in use(not shown)**

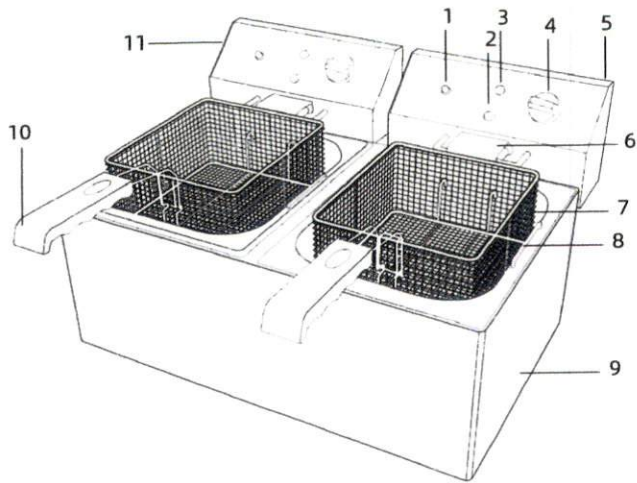

Electric Fryer Parts EGEF-12L-2:

1. Reset button
2. Thermostat indicator (yellow)
3. Power indicator (green)
4. Temperature control knob
5. Micro switch
6. Heating element cover
7. Oil tank handle
8. Main housing
9. Rubber feet
10. Basket handle
11. Oil tank
12. basket
13. Night cover-located on top of the fryer when not in use(not shown)

Note: This Dual Fryer has 2 plugs, one plug supplying power to each side.

Electric Fryer Parts EGEF-101V:

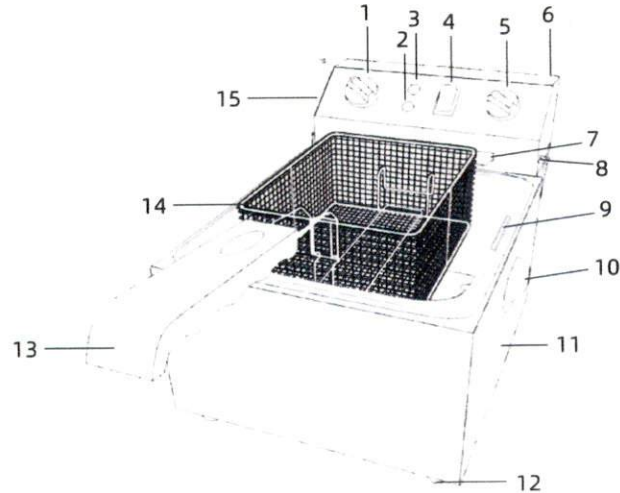

1. Temperature control knob
2. Thermostat indicator (yellow)
3. Power indicator (green)
4. Timer on-off switch
5. Timer control knob
6. Reset button-located on the back of the fryer
7. Basket hanger
8. Fryer head hanger
9. Oil tank
10. Fryer handle
11. Main housing
12. Rubber feet
13. Basket handle
14. Basket
15. Night cover-located on top of the fryer when not in use(not shown)

Electric Fryer Parts EGEF-101V-2:

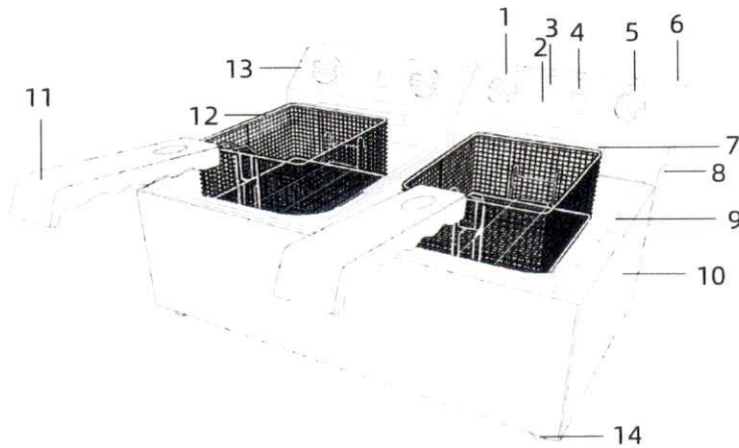

1. Temperature control knob
2. Power indicator (green)
3. Thermostat indicator (yellow)
4. Timer on-off switch
5. Timer control knob
6. Reset button-located on the back of the fryer
7. Basket hanger
8. Fryer head hanger
9. Oil tank
10. Main housing
11. Basket handle
12. Basket
13. Night cover-located on top of the fryer when not in use(not shown)

Note: This Dual Fryer has 2 plugs, one plug

supplying power to each side.

Electric Fryer Parts EGEF-12V:

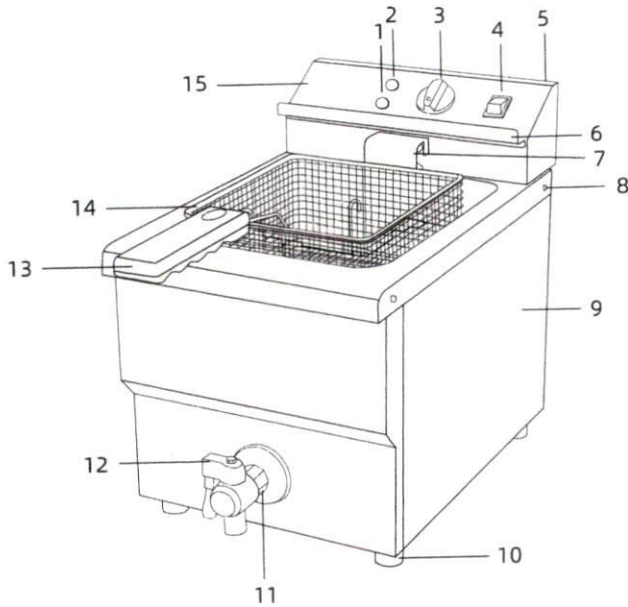

1. Power indicator (green)
2. Thermostat indicator (yellow)
3. Temperature control Knob
4. Main switch
5. Reset button-located on the back of the fryer
6. Basket hanger
7. Heating element cover
9. Main housing
10. Rubber feet
11. Oil drain valve
12. Oil drain tap
13. Basket handle
14. Basket
15. Night cover-located on top of the fryer when not in use(not shown)

Specifications

Model Number	Voltage	Power	Plug	Temp. Controls	Temp. Range	Oil Tank Capacity	Baskets	Overall Size (mm)
EGEF-10L	120VAC	1.8kW	NEMA 5-15P	1	50~200°C	10L	1	265*415*290
EGEF-10L-2	120VAC	1.8kW+1.8kW	NEMA 5-15P(2)	2	50~200°C	10L+10L	2	550*415*290
EGEF-101V	120VAC	1.8kW	NEMA 5-15P	1	50~200°C	10L	1	265*415*290
EGEF-101V-2	120VAC	1.8kW+1.8kW	NEMA 5-15P(2)	2	50~200°C	10L+10L	2	550*415*290
EGEF-12L	240VAC	3.3kW	NEMA 6-15P	1	50~200°C	12L	1	260*410*345
EGEF-12L-2	240VAC	3.3kW+3.3kW	NEMA 6-15P(2)	2	50~200°C	12L+12L	2	550*410*345
EGEF-12V	240VAC	3.3kW	NEMA 6-15P	1	50~200°C	12L	1	285*395*405
EGEF-12V-2	240VAC	3.3kW+3.3kW	NEMA 6-15P(2)	2	50~200°C	12L+12L	2	575*395*405

Remarks: "-2" at the end of Model No. means dual version of single version. For instance, EF-10L-2 means dual version of EF-10L. Each working station of Dual deep fryers are identical to Single deep fryer.

OPERATING INSTRUCTIONS

These fryers are plug-in products but commercial safety regulations require additional earthing to be carried out. Only a qualified technician should install the product. There is an earth bolt  at the back of the fryer. Complying fully with safety regulations, connect the earth wire with suitable Cable. A suitable switch, fuse breaker and plug socket should be installed near the fryer. You may see smoke coming from the elements when the machine is first switched on, this is normal.

NOTE: During the first use of the Deep Fryer, the oil pan and frying basket may emit a slight odor. This is normal and will quickly dissipate.

WARNING! This unit should not be used to boil water.

WARNING!: This appliance generates heat and escaping steam during use. Use proper precautions to prevent the risk of burns, fires, or other injury to persons or damage to property.

WARNING!: RISK OF SEVERE BURNS. When in use, parts of the fryer will be too hot to touch.

Please make sure that the basket handle is securely locked in the right place.

1. Before using this product, ensure that the electricity supply conforms to the rating markings on the fryer and check there is no damage to the

2. Always ensure the element cover is in place within the oil tank. It sits on top of the heating element and is designed to protect it.
3. Add oil to the tank. Be aware of the oil indication marks. For safe operation of the product, **DO NOT** allow the level of oil to exceed the 'H' High mark when adding oil. The oil level **MUST** also exceed the 'L' low mark for safe usage.
4. Ensure the fryer is plugged into the socket and that power is switched on. The green power indicator lights up.
5. Rotate the temperature control clockwise to required setting. A yellow, thermostat indicator lights up showing that the oil is being heated. The green power indicator remains lit.
6. When the oil reaches the selected temperature the yellow thermostat indicator goes out. The light will cycle on and off as the thermostat maintains the selected temperature of the oil.

For EF-101V and EF-101V-2 (with Timer) Models only:

If you don't want to use the "TIMER" function, keep the "TIMER" switch at "OFF" position.

If you want to use the "TIMER" function, follow the steps below:

- **Rotate the temperature control knob to the desired temperature.**
- **Turn on the "TIMER" switch.**
- **Rotate the timer dial to the desired time. When the desired time reaches, there will be a "DING" sound to remind you and the fryer will cutoff power automatically. The basket can now be taken out of the oil and hang on the drainage rod on the fryer head.**

7. The frying basket is for cooking small food items. **Before using ensure the handle is securely locked in place.** Lower the basket containing the food for frying into the hot oil. When food is cooked the basket can be lifted to a draining position by placing the hook located on the basket into the rods on tank.

WARNING: RISK OF SEVERE BURNS. Ensure the lid/cover is not wet or covered in condensation when placed on the fryer. Overly wet food can cause surge boiling. Even small amounts of water in hot oil can burn you.

8. If the cooking temperature gets too high, an overheat facility will cut in and turn the fryer off. The product can be reset by allowing the unit to cool to room temperature then pushing the reset button found at the back (or front) of the fryer. Seek advice from a qualified technician if the overheat facility repeatedly cuts in.

9. When frying is completed, the temperature control must be turned anti clockwise to the 'MIN' position and the power switch turned off.

10. Unplug the fryer from the mains power when not in use.

11. When cooking is finished, the oil must be removed from the fryer and stored elsewhere. This procedure **MUST** only be carried out when the oil is **COMPLETELY COOL**. **Take caution: Oil can stay hot for 6-7 hours.** Ensure that the fryer is unplugged from the mains. **WARNING: RISK OF SEVERE BURNS. Hot oil is capable of causing severe burns.**

For fryer with detachable oil tank models (EF-10L, EF-10L-2, EF-101V, EF-101V-2, EF-12L, EF-12L-2) only:

- 12a. When temperature of the oil cools down, remove the heating element cover, control box and element then pour the old oil out of pot.

For EF-12v and EF-12V model only:

- 12b. Please pour the old oil out of pot when temperature of oil cools down. First, turn off power, allow the hot oil to cool down, then put a oil tray under the oil drain tap and open the drain tap to pour oil into the oil tray.

13. It is suggested to clean the oil tank and heating element when oil has been removed from it.

WARNING: Do not open the drain valve until the pressure has been reduced to approximately atmospheric pressure.

NOTE: There is a safety micro-switch which will activate and turn off the heating elements when the control box is lifted up or moves out of position. The micro-switch works at once. It cuts off power to protect personal safety and to prevent the electric heating tube being burned out.

Care, Maintenance, Storage and Transportation

IMPORTANT: Always unplug fryer from the mains power socket and allow to cool completely before cleaning.

Take caution: Oil can stay hot for 6-7 hours.

DO NOT spray or splash water directly onto the product or use a water jet to clean it.

DO NOT submerge any part including the control box, elements, electric plug or mains lead in water or other liquids.

DO NOT use wet cloths, steel wool pads or abrasive creams to clean the grill plates, outer body of the grill or power cord. When not in use, turn the temperature control to the 'MIN' position, turn off power switch and unplug fryer from the mains power Supply. Store fryer in a safe, clean, dry, well ventilated place if it is not going to be used for any length of time.

DO NOT handle the fryer when it contains hot oil.

DO NOT turn the fryer upside down. This will help prevent the possibility of damaging it.

WARNING! Allow the Deep Fryer to cool fully before emptying the oil and cleaning the appliance.

1. Make sure your Deep Fryer is unplugged and the filled oil pan has cooled completely.
2. Remove the night cover.
3. Remove the frying basket from the oil pan.
4. Gently pull up to remove the control panel/heater assembly. Use caution as oil may splash out of the oil pan. Wipe control panel/heater assembly with a damp cloth and dry completely. Handle the heating element and assembly with care.

CAUTION: Do not immerse the control panel/heater assembly in water. Doing so could permanently damage the Deep Fryer.

5. Grasp oil pan handles. They will slide up and out to allow oil pan removal from Deep Fryer body.
6. **CAUTION:** Oil in oil pan is heavy! Use care when moving.
7. Carefully strain the oil from the oil pan into a suitable container. (See DRAINING & RECYCLING OIL for complete details.)

NOTE: It is best to work over a sink or garbage can in case of any spillage.

9. **Seasoning the Frying Basket:** Place the clean and dry, empty frying basket in the oil. Set temperature to 390°F. When the temperature is reached, remove the frying basket. Allow it to cool. Then repeat the procedure. After seasoning, the frying basket can be placed in the dishwasher for a thorough cleaning.

10. **Oil Pan Cleaning:** Soak in hot, soapy water. Use a stiff nylon brush to remove stubborn or burned-on residue. Do not use harsh or abrasive cleaning products they may damage the surface of the oil pan.

11. **The frying baskets should be hand washed before first use and should be seasoned in oil before going into the dishwasher for the first time. Dry parts thoroughly after cleaning.**

12. Wash deep fryer body in hot, soapy water by hand. Dry all parts thoroughly. **IMPORTANT:** Make sure the heating element cover and oil pan are completely dry after washing and before use.

HELPFUL HINTS

Frying

- Never over-fill the frying basket with food. Maximum basket capacity is 2/3 full.
- Fry more batches of smaller amounts of food. Best results are obtained when the hot oil can freely circulate all around the food.
- In general, pre-cooked foods require higher temperatures and less cooking time.
- Cut or sort food into uniform sizes. Cook same-size pieces together so they will be cooked in the same amount of time.
- Avoid spatter foam. Dry damp foods before placing into oil. Be sure foods are free from ice crystals and excess moisture before frying.
- When using a breading, evenly coat the food to be fried. Fine, uniform crumbs stick better than coarse, uneven ones. Shake off all extra breading to help keep oil clean.
- To prevent contamination of the oil, do not add salt or other spices to the food during frying or when the food is draining above the oil.
- Space coated foods so they do not touch while cooking.
- For best results when frying doughs or foods dipped in a liquid batter, place the foods into the basket first and then lower the frying basket into the hot oil.
- **WARNING!** Never, under any circumstances, add water or any other liquid to the oil.
- Never over-fill or under-fill the oil pan. Before frying, check to make sure the oil level is between the MIN and MAX marks on the inside of the oil pan.
- **WARNING:** Under- or over-filling the oil tank may damage the Deep Fryer and could result in serious personal injury.
- See **RECOMMENDED OILS FOR DEEP FAT FRYING** for the best oils to use and approximate smoke points.
- Never use hard fats (melt first).
- Never mix different oils together to fry foods.
- Never use butter or margarine to fry foods.
- When frying fish or seafood, the oil may absorb a “fishy” taste or odor. To eliminate transferring any “fishy” taste or odor to other foods, the oil must be changed.

DRAINING & RECYCLING OIL

WARNING! Allow the Deep Fryer to cool fully before draining and recycling the oil.

1. Although oil does not have to be changed after every use, frying oil should be filtered and recycled regularly.

2. Following the detailed procedures described in Care & Cleaning Instructions, remove the frying basket and heating element cover.

3. Using a large funnel, filter the cooled oil through a fine sieve into a wide-neck, airtight, covered container.

NOTE: Alternatively, place a piece of clean cotton material into the frying basket to filter used oil.

4. This process is safe to repeat after 3 or 4 frying sessions without the oil deteriorating.

5. When oil is mainly used to fry potatoes, and is filtered after every use, oil may be used up to 8 times.

6. As oil will absorb food flavors and odors, it's a good idea to label containers with the type of food that was cooked in the oil. For example: sweet desserts, vegetables, chicken, fish, etc.

NOTE: DO NOT pour used oil down any drain. Discard used oil into a lidded container and dispose properly.

TROUBLE SHOOTING

If a problem occurs that does not appear on this table, stop using the fryer and seek help from the manufacturer, a qualified technician or an authorized dealer.

Temperature safety reset switch

This unit is equipped with a switch that cuts off power if the oil temperature reaches 465°F (240°C). This switch has a manual reset. The reset switch and cover is usually located on the back panel of the unit, EF-12L series on the Front. Determine what caused the safety switch to activate and correct it.

Possible causes include: dirty oil, low oil level and element not properly submerged in oil.

To reset the temperature safety switch, follow the 4 steps below:

1. Wait until the oil has cooled to 300°F (148°C) or below.

2. Remove the switch cover by unscrewing the cover counterclockwise.

3. Use a pen or similar narrow tool and press the reset button down. The button should stay in the down or in the set position.

4. Place the switch cover back on and secure by screwing clockwise.

Micro Switch

This unit is equipped with a Micro Switch. The switch allows power to the heating element when it is in the correct position. See Figure below. Micro Switch:

1. When the head (C) is in the correct or down position the Micro Switch (A) is pushed in from pad (B) and the heating element will be supplied with power.

2. When the head (F) is in the up position or removed from the unit and pad, (E) switch goes to the "OFF" (D) position and cuts power to the heating element.

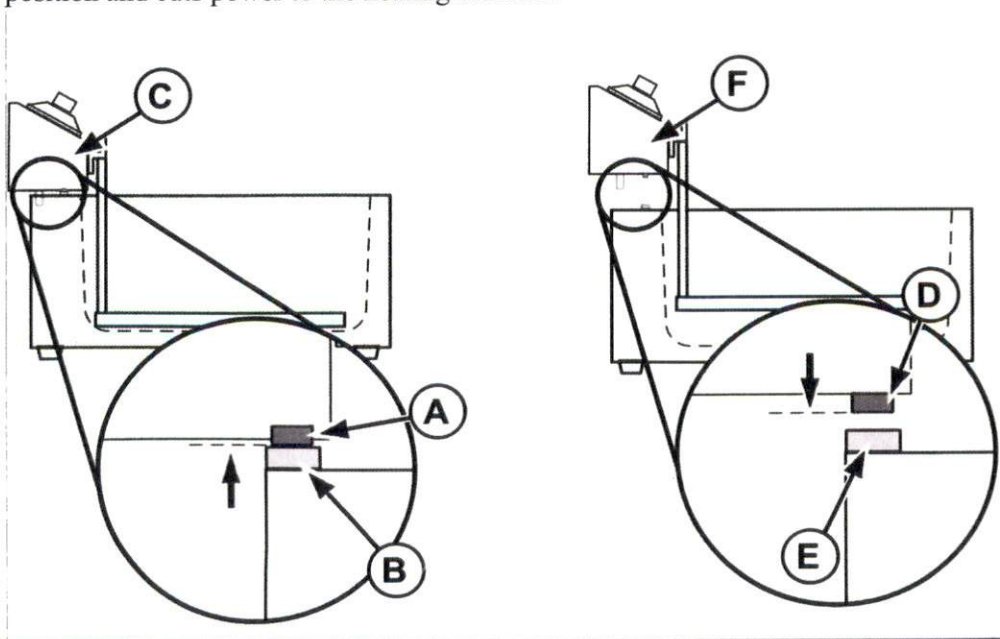

Other Possible Troubleshooting Chart

Problem	Cause(s)	Solution(s)
Power indicator not on when fryer plugged in.	<ol style="list-style-type: none"> 1. Plug is not in socket properly. 2. Fuse has blown 	<ol style="list-style-type: none"> 1. Remove plug and insert correctly. 2. Replace suitable fuse
Thermostat indicator not working and fryer not heating up.	<ol style="list-style-type: none"> 1. Safety overheat stat maybe activated 2. Connection to heating element faulty. 3. Heating element is faulty. 	<ol style="list-style-type: none"> 1. Press the safety reset button on the back of the machine, check and service the machine. Contact a qualified technician or an authorized dealer if safety reset repeatedly needs resetting during normal use. 2. Contact a qualified technician or an authorized dealer for heating element fault. 3. Contact a qualified technician or an authorized dealer for heating element fault.
Power indicator on but fryer not heating up.	Temperature control is faulty.	Contact a qualified technician or an authorized dealer.
Temperature control is working but power indicator is not on.	Power indicator is faulty	Contact a qualified technician or an authorized dealer.
After heating up, heating element no longer seems to be maintaining temperature.	Overheat facility has cut in	Push the reset button at the back (or front) of the fryer.