

Specifications

Description

Adcraft's granita/slushy machines are perfect for any establishment wanting to offer cold or frozen drinks. It's compact and streamlined design allows it to fit even in the smallest of areas. The powerful 1/3 HP motor cools the product inside quickly. The continuous agitator system and stainless steel cooling cylinder keeps the product inside the clear polycarbonate hopper moving and fresh while in use. The non-drip tap is easy to use and prevents product leakage when serving. Nighttime running feature is great for conserving energy after hours of operation. LED lighting built into the top panel helps brighten the product inside the hopper. 115V/60Hz. 6' power cord with a NEMA 5-15P plug. This unit is CE Certified and backed by Adcraft's 1 year replace or repair warranty.

Construction

- Clear 3 gallon polycarbonate hoppers with lighted top panel
- Frame is constructed of stainless steel and durable high impact plastic
- Non-drip tap mechanism is easy to use and prevents leakage
- Removable drip tray with float indicator for easy cleaning
- Non-slip feet for stability

Cooling and Agitator System

- Refrigeration system uses R-404A refrigerant
- Adjustable digital thermostat with cold drink/slushy settings
- Continuous agitator system keeps product fresh and mixed while in use
- Stainless steel cooling cylinder keeps the product cold/frozen
- Nighttime running feature helps to conserve energy

Electrical

- Separate on/off switches for power and agitator(s) gives you complete control of the unit's operation
- LED lighting built into the top panel helps illuminate the product inside the hopper
- 115V/60Hz electrical connection
- 6' power cord with NEMA 5-15 plug

Certifications/Approvals



Granita/Frozen Beverage Dispensers

Models:

SGM-1

SGM-2



SGM-1



SGM-2

Warranty: This product is protected by Admiral Craft Equipment Corporation's 1 year limited warranty. Should your product fail under normal use it will be repaired or replaced up to one year from date of purchase.



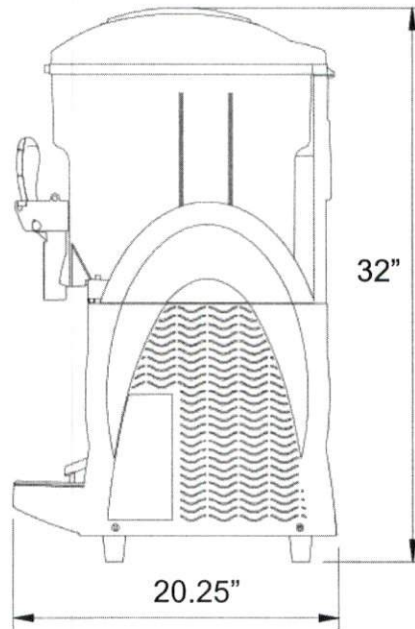

Granita/Frozen Beverage Dispensers - SGM-1 and SGM-2

Plan View



Specifications

Item Number	Description	Total Capacity	Volts	Wattage	Amps	NEMA Plug
SGM-1	Single Hopper Granita/Slushy Dispenser	3 Gallons	115V	500W	4.3	5-15P 
SGM-2	Double Hopper Granita/Slushy Dispenser	6 Gallons	115V	960W	8.3	5-15P 

Item Number	Item Dimensions	Refrigerant
SGM-1	10.5"W x 20.25"D x 32"H	R-404A
SGM-2	18.5"W x 20.25"D x 32"H	R-404A

Shipping Info

Item Number	Box Dimensions	Gross Weight	Net Weight
SGM-1	13.75"W x 23"D x 39"H	84 lbs	70.5 lbs
SGM-2	21.5"W x 23"D x 39"H	145 lbs	132 lbs

For more information about this or any of our other products go to www.admiralcraft.com. This item is listed on AutoQuotes. For full explanation of warranty coverage on this product please refer to warranty page located in the owner's manual and warranty section at www.admiralcraft.com. Specifications subject to change without notice. Please confirm at time of order.

©2015 Admiral Craft Equipment Corp.

Admiral Craft Equipment Corp.

940 South Oyster Bay Rd. • Hicksville, NY 11801 • P: 800-223-7750 • F: 800-447-7751 • www.admiralcraft.com

Specifications

[Store Locator](#)

[Cart](#)

[Accessibility](#)

[Terms & Conditions](#)

[Privacy](#)

[Interest-Based Ads](#)

[State Privacy Rights](#)

[Health Data Privacy](#)

[Do Not Sell/Share My Personal Information](#)

[Limit Use of My Sensi Personal Information](#)

In-store pricing may vary. Prices and off subject to change. © 2014 Best Buy. All rights reserved. BEST BUY, 1 BEST BUY are trademarks of Best Buy and/or its affiliates.

Insignia™ 5.0 Cu. Ft. Garage Ready Chest Freezer - White

[4.8 \(7,339 Reviews\)](#)

Capacity 5 cubic feet

Color Finish White

General

Product Name 5.0 Cu. Ft. Garage Ready-Chest Freezer

Brand Insignia™

Model Number NS-CZ50WHO

Color White

Color Finish White

Dimension

Product Height 33 1/2 inches

Product Width 24 15/16 inches

Product Depth 21 3/4 inches





[Store Locator](#)

[Pickup](#)
[Choose a store](#)
Cart

[Shipping](#)
Enter zip code

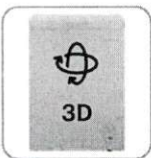
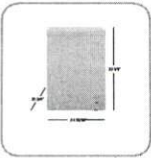

Specifications

Insignia™ - 5.0 Cu. Ft. Garage Ready-Chest Freezer - White

4.8 (7,339 Reviews)



[More Buy](#)

Open Box for
\$139.99

Capacity 5 cubic feet

Color Finish White

General

Product Name 5.0 Cu. Ft. Garage Ready-Chest Freezer

Brand Insignia™

Model Number NS-CZ50WHO

Color White

Color Finish White

Dimension

Product Height 33 1/2 inches

Product Width 24 15/16 inches

Product Depth 21 3/4 inches

Specifications

Product Height 33 1/2 inches

Product Width 24 15/16 inches

