

## GENERAL NOTES AND REQUIREMENTS.

- Workmanship shall conform to NECA installation standards including NECA 1.
- Installation shall comply with National Electrical Code (NEC/ NFPA 70), state building code, and all requirements of the local inspector (furnish inspection certificate). All work shall be by licensed electrical contractor.
- The contractor shall refer to the architectural plans for floor plan dimensions and not scale these drawings. The location of all wall mounted devices, including mounting heights, shall be field verified with the architect prior to rough-in. Coordinate locations of all light fixtures with the reflected ceiling plans. Light fixtures installed in mechanical areas shall avoid mechanical piping, equipment, ductwork, etc.
- Contractor shall comply with all requirements of the 2018 NC Building Code and Accessibility Code which are applicable to this project regardless of whether all details are indicated on plans. All receptacles, switches, and other electrical devices required to be ADA accessible shall be mounted per ANSI 117.1 sections 308 AND 309.
- All electrical equipment shall be installed so that all code required and manufacturer recommended working/ servicing clearances are maintained. Installation shall fully comply with NEC 110.26 and NEC 408.18 for clearance requirements.
- All wall outlet boxes, receptacles, switches, cover plates, etc. shall be commercial grade, standard or heavy duty except where specified. Verify color/ material for all devices and cover plates prior to order. Provide label for each device identifying the circuit serving the device. Verify if label should be on inside or outside face of cover plate with building management/ tenant. All 15 and 20 amp, 125V and 250V non-locking receptacles shall be listed as tamper resistant, per NEC 406.12, when installed in the following areas: dwelling units in areas specified by NEC 210.52 and 550.13, guest rooms and suites of hotels, child care facilities, preschool and elementary education facilities, and in patient rooms, bathrooms, playrooms and activity rooms of pediatric or similar facilities.
- The electrical contractor shall coordinate any and all work with other trades involved in the project, prior to installation of electrical equipment, so as to avoid conflicts during construction and to allow for optimum maintenance and working space.
- All branch circuits shall be in 3/4" minimum zinc-coated EMT, IMC, or RMC as permitted or required by the NEC. LFMC (or FMC as permitted) shall be used for final connections to equipment subject to vibration. A deduct price for MC cable may be offered for approval, where permitted by owner and NEC and conduits completely concealed from view. Schedule 40 PVC conduit may be used for underground feeders/ branch circuits or underground low voltage system conduits located below slab on grade or buried outside of the building, or in concrete block walls. PVC schedule 80 conduit may be used on the building exterior where permitted by code. Contractor shall include cost of painting all exposed conduits subject to public view. Conduit sizes noted on these plans are based on EMT conduit. Where other permitted raceway types are used, contractor shall adjust conduit sizes as necessary based on type of raceway used and allowable fill. Provide pull wire in all empty conduit. Junction box covers shall be permanently labeled and conduit shall be labeled every 10'.
- All wire and conduit sizes are based on 75° C THHN/THWN copper conductors unless otherwise noted. All conductors, terminations & devices shall be rated for minimum 75° C. All conductor and conduit sizes are calculated based on installation of no more than 3 current carrying conductors per conduit, neutral(s) included. Unless otherwise noted, contractor shall not install more than 3 current carrying conductors per conduit with the following exception: up to 9 current carrying conductors may be used in a single raceway where permitted by the NEC when minimum #12 AWG (THHN 90°c) is used and when all included circuits are protected upstream by 20 amp overcurrent devices and no other derating conditions exist.
- All conductors shall be copper type THHN, or XHHW, solid for #10 AWG or #12 AWG, and stranded for all larger sizes. Minimum conductor size shall be #12.
- Conduits and cables shall be concealed wherever possible by either routing above ceiling, in interstitial spaces or running exposed in unfinished spaces where possible. Conduits may be run exposed in mechanical areas or other areas not subject to public view where approved by the owner. Wherever conduits or cables are approved to be exposed, conduits and cables shall be run parallel or perpendicular to structural elements and shall be run and bundled in groups, and the installation shall be neat and orderly. Even when exposed, conduits and cables shall be routed to minimize view from personnel. Seal all penetrations air tight around all conduits passing through walls or floors. Use appropriate penetration protection when conduit passes into or through rated assemblies.
- Where branch circuit total length is greater than sixty five (65') feet from the panel, see voltage drop schedule for wire size adjustment.
- All mounting heights indicated are given to the bottom of the device, unless noted otherwise.
- Where used in these documents, the word "provide" shall mean to furnish and install the item or equipment as well as make the final connection required.
- All light fixtures shall be supported independently of the suspended ceiling system.
- The electrical contractor shall provide all necessary disconnects, switches, receptacles, etc. under the electrical bid and shall include all necessary circuits to and make final connections to the equipment furnish by all suppliers. Coordinate closely with other trades.
- All breakers, disconnect switches, and fuses sizes, indicated for mechanical equipment, shall be verified with equipment supplier and mechanical contractor, before the purchase or installation of that equipment.
- All disconnect switches are to be fusible type. Fuses shall be the appropriate type for the load served by Busmann or equal. Unless unsuitable, fuses rated 1200A or higher shall be Class I, fast-acting, and shall have a clearing time of 0.07 seconds at the available fault current per NEC 240.67. Submit fuse trip curves along with available fault current at the service entrance for engineer verification prior to beginning work or ordering equipment. The contractor shall compare all installed equipment nameplate information with the electrical plans/ schedules and notify the engineer immediately of any discrepancies. The contractor shall coordinate all fuse sizes with actual installed equipment nameplate information prior to purchasing or installing fuses. Where the nameplate information does not indicate an overcurrent protection size or maximum ampacity rating, fuses shall be installed per the electrical plans assuming other equipment parameters are in agreement with nameplate data.
- Provide grounding conductor for all circuits per NEC. Building ground shall meet all requirements of NEC 250.
- Ground telephone equipment per NEC. If telephone service is not located within 20' of electrical service, then provide separate grounding electrode as required per NEC 800.
- All multiwire branch circuits shall have multipole breakers as required by NEC 210.7.
- All circuits 100 amp and larger shall be megger tested prior to energizing. All other circuits shall be tested for continuity prior to energizing.
- The contractor is responsible for properly disposing of all waste materials, demo materials and other trash. This includes but is not limited to proper disposal of mercury containing lamps, batteries, recyclable materials.
- Contractor shall provide engineer with shop drawings/ submittal data for lights, switchgear/ panels, floor boxes, fire alarm devices, and any other products deemed necessary for review. Provide these in editable pdf format via email through project manager, GC, architect or other proper channel. Expected review duration, and industry standard, is 2 weeks from date of receipt by engineer. All submissions should include and acknowledge this review duration unless otherwise specifically discussed and agreed upon in advance.
- It is the sole responsibility of the contractor to coordinate w/ all other trades regarding voltages, loads, circuit breakers, etc. prior to beginning any work.
- All switchgear/ panels shall be commercial grade from a reputable national manufacturer such as Square D, Eaton, Siemens and GE. Panels shall be rated as indicated on panel schedules/ electrical riser diagram. If discrepancies are found, contact engineer immediately.
- Engineer has reserved the right to choose the software package(s) deemed most efficient to deliver these plans for permitting, bid, and construction. Engineer considers any other digital files created during this process as instruments of service, and as such remain the property of the engineer. The contractor should not assume that digital files in any format will be made available during bidding or after award other than PDFs. If digital files are requested, engineer reserves the right to selectively provide them when available and/or may request additional considerations for the time incurred to prepare them.
- Contractor shall verify all areas that are used as a return plenum with mechanical contractor and provide plenum rated cable for all cables not in metal conduit. PVC is not allowed in plenum space. This "cable" includes all telecommunications, fire alarm, or control wiring above ceiling.
- Contractor shall comply with all applicable seismic requirements of the area.
- All underground raceway entering the building, (i.e. through a foundation wall or through the floor) shall be sealed in accordance with NEC 225.27 and 300.5(F). raceway seals and sealants shall be approved and listed for the specific application and materials.
- Contractor shall provide support bushings/conduit stops for vertical branch circuits and feeders where required per NEC 300.19(A).
- Buildings equipped with a Bi-Directional Antenna system (BDA) contractor shall test the areas of construction before and after construction activities per NC Fire Code section 510.6.1 and possibly supplement the existing system to meet the requirements of NC Fire Code section 510.
- Electrical boxes, conduit, and wiring shall not be recessed into or penetrate structural members. Boxes/conduits shall be surface mounted to structural member and/or recessed in stud wall where possible. Coordinate with architect.
- All equipment associate with or connected to the electrical, fire alarm or data systems or otherwise included in the drawings/ scope of work shall be listed and labeled by a third party that is acceptable to the AHJ.
- All non-locking type 125 volt, 15 and 20 amp receptacles that are controlled by an automatic control device or that incorporate control features that remove power from the outlet for the purpose of energy management or building automation shall be labeled per NEC 406.3(E).
- All wiring for this assembly occupancy shall be per NEC 518.4

## Electrical Abbreviations

A	above- indicates a device is to be mounted with the bottom of box 2" above back splash unless noted otherwise.
AFF	above finished floor
AG	combination of 'A' and 'GFCI' (above counter and ground fault circuit interrupter)
ARCH	architect
C	ceiling- indicates a device is to be mounted in flush ceiling tile.
EC	electrical contractor
EX	existing
EXT	exterior
FA	fire alarm
FURN	furniture
G	GFCI- indicates a device with integral ground fault circuit interrupter (GFCI) protection and/or protected by upstream GFCI outlet.
GF/I GFCI	same as 'G'
HG	hospital grade
IG	device shall have isolated ground and will require isolated ground circuitry back to an isolated ground bar in panelboard.
JB	junction box
MC	MC cable (when referring to NEC, wiring methods, or wiring type)
MC	mechanical contractor (when not referring to NEC wiring methods or type)
MECH	mechanical contractor
NTS	not to scale
OC	on center
PC	plumbing contractor
PLUMB	plumbing contractor
S	surface- indicates device is to be surface mounted.
TP	tamper proof device per NEC 406.12
W/	with
WP	indicates a device rated for exterior use and is weatherproof or weather resistant with an approved weatherproof in-use cover.

## Voltage Drop Schedule

120 V branch circuits up to 8 amps (1.0 kVA)		
Distance of run, in feet		Wire size
1'	- 120'	#12
121'	- 190'	#10
191'	- 300'	#8
301'	- 470'	#6

120 V branch circuits from 8 to 14 amps (1.7 kVA)		
Distance of run, in feet		Wire size
1'	- 65'	#12
66'	- 110'	#10
111'	- 170'	#8
171'	- 270'	#6

277 V branch circuits up to 14 amps (3.9 kVA)		
Distance of run, in feet		Wire size
1'	- 160'	#12
161'	- 250'	#10
251'	- 390'	#8
391'	- 620'	#6

Contractor shall upsize branch circuit conductors based on load and length as indicated in schedule above. Wire sizes indicated in general notes and schedules are minimum wire sizes and shall be adjusted for length.

## Renovation Notes:

- See architectural drawings for the extent of renovations. Locations where an existing ceiling is being raised, or a new ceiling is being installed, the contractor shall include all costs associated with relocating existing devices and systems components necessary to accommodate the installation of the new ceiling. This shall also include relocating any equipment requiring access when a new or changed ceiling does not provide access (hard ceiling).
- Contractor shall field verify existing conditions prior to bid.
- Reconnect circuits as shown on plans. Devices/fixtures shown to remain shall remain connected to their existing circuit. If circuit is broken during demolition, device/fixture shall be reconnected to existing circuit as necessary for complete and working system. Portions of circuits or circuits in their entirety broken during demolitions shall be removed (conductors and conduit). If the entire circuit, remove conductors and conduit back to panel, turn breaker off and mark as spare.
- Existing light fixtures shown without circuits or controls are existing to remain as circled and/or controlled. Existing fixtures shown with new circuitry or controls shall be connected and/or controlled as indicated.
- If existing panel serving existing to remain equipment is demolished or relocated, the existing to remain equipment shall be reconnected to relocated or new panel as required.
- Clean all existing light fixtures to remain and replace defective parts as necessary for a complete and functional fixture (IE driver/ballast, battery, lens, etc). Relamp if necessary.
- Test all existing emergency batteries in fixtures and/or in emergency battery units in the space. Replace defective batteries.
- Mount all new switches, outlets, or other electrical devices flush in existing walls. Boxes and conduit shall be concealed

## Electrical Legend

Symbols shown below are indicative of new devices. See Linetype Legend for distinction of existing and demolition devices.

### Floor Plans

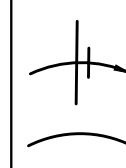

Home run to panel/ branch circuit connection- short cross line(s) represent phase conductor(s) (hot), long cross line(s) represent grounded conductor(s) (neutral), equipment grounding conductor (ground) required but not shown. minimum size per NEC requirements based on circuit breaker / schedule / voltage drop table.

All duplex and quad receptacles shall be NEMA 5-20R unless otherwise noted.

Duplex receptacle  
Power receptacle  
Quad receptacle  
Isolated ground duplex receptacle

16" AFF or as otherwise noted

Telecommunications wall outlet - 16" AFF or as noted (run 3/4" EMT to accessible point above ceiling.) Provide pull wire. Outlet/devices, bushings, and cables provided by tenant/ cabling contractor.

Television wall outlet - 16" AFF. Run RG6 in 3/4" EMT to telephone backboard or as indicated on plans.

AV display wall box - confirm height prior to rough-in. Provide Legrand wall box (IEF5B2) with duplex power and separate AV compartment with 2" conduit to above accessible ceiling w/ bushing and pull string. Verify device plates with tenant/AV contractor.

Junction box w/ whip for power for furniture system. Verify exact location and requirements with system supplier prior to rough-in and connect as required.

Junction box adequately sized to accept 2" conduit for telecommunications for furniture system. Verify exact location and requirements with system supplier prior to rough-in. Stub 2" conduit to accessible point above ceiling with pull wire.

Card reader- verify mounting height with tenant prior to beginning work. Stub 3/4" EMT to above ceiling with pull wire. Outlet/device and all low voltage wiring by tenant/security contractor. Coordinate with tenant/security contractor.

Junction box above ceiling for furniture systems. Power poles provided by furniture manufacturer/vendor. Verify location & requirements w/ furniture manufacturer/vendor prior to beginning work. Connect furniture systems as required.

Junction box

Telephone backboard - 4'x8'x3/4" fire-treated plywood. Pull #6 ground wire and terminate with 1/4" x 2" x 12" ground bar with holes every 1". Mount to backboard with stand-off insulators.

Electrical panel

Step-down transformer

Electrical disconnect

Motor rated switch

All lighting control switches shall be mounted at 44" AFF unless otherwise noted.

Single pole switch  
Dimmer switch (slide type) appropriate for load served  
Line voltage motion-sensing switch. Wattstopper #PW-301  
3-way wall switch  
4-way wall switch  
Line voltage motion-sensing 0-10v dimmer switch. Wattstopper #PW-311  
Line voltage dual relay motion-sensing switch. Wattstopper #PW-302. To be connected as double switch control.  
Double switch (used when two switch legs are connected to each fixture for bi-level switching, step dimming or similar.)  
Low voltage wall/ceiling mounted motion sensor. Wattstopper #DT-200. Mount on wall at 10' AFF where ceilings are not present or are over 10' AFF. Mount to ceiling where ceilings are 10' AFF or lower.

120/277V to 24V power pack. Wattstopper #BZ-150  
Low voltage 360° ceiling mounted motion sensor. Wattstopper #DT-300  
Low voltage 360° ceiling mounted motion sensor. Wattstopper #DT-305-3  
Low voltage 360° ceiling mounted daylighting sensor. Wattstopper #LS-301.

See fire alarm legend for fire alarm symbols & specifications

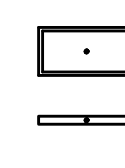

Overhead fixture unless otherwise noted. See fixture schedule



Downlight / pendant style fixture. See fixture schedule.

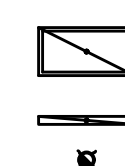

Slash or shading indicates fixture connected ahead of switch/controls and to operate as night lights (fixture will be on 24/7 unless otherwise noted)



Exit sign, faces and arrows as indicated. See fixture schedule.



Emergency wallpack fixture. See fixture schedule.

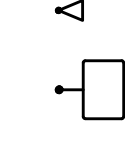

Combo emergency / exit fixture. See fixture schedule.

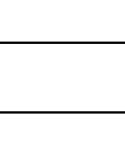

Wall sconce/ mount fixture. See fixture schedule.

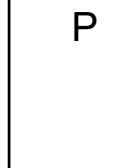

Flood light/ track head style fixture. See fixture schedule.

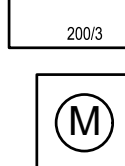

Pole mounted fixture. See fixture schedule.

## Detail Sheets

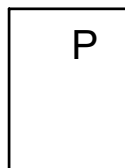

Electrical panelboard

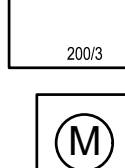

Main breaker or minimum ampacity

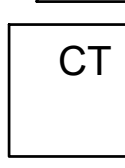

Meter in meter base

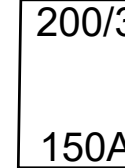

CT cabinet



Frame size/ number of poles

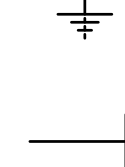

Fusible disconnect, frame and fuse size as indicated or noted.

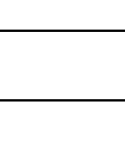

Fuse size

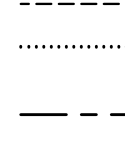

Transformer designation

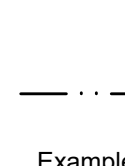

Transformer size

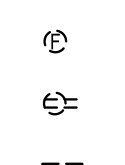

Transformer, size and designation as indicated. Primary voltage as noted in panel schedule/ for primary feed. Secondary voltage as noted in panel schedule/ for load supplied.

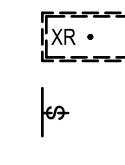

Service ground

## Linetypes

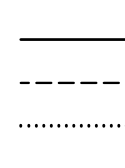

New device unless otherwise noted



Existing device to remain

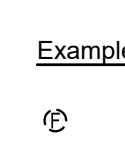

Existing device to be demolished

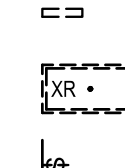

New underslab or underground connection. Existing and demo underground noted with existing or demo linetype. New connections not specifically shown to be underground are not necessarily required to be run overhead unless noted as such.



Low voltage wiring

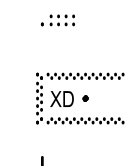

Examples of existing and demolition symbols using above linetypes.

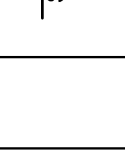

Existing floor box to remain

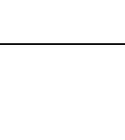

Existing duplex receptacle to remain



Existing panel to remain



Existing light fixture to remain



Existing switch to remain



Existing light fixture to remain



Existing switch to remain



Existing duplex receptacle to be demolished



Existing panel to be demolished or relocated



Existing light fixture to be demolished or relocated



Existing switch to be demolished or relocated

See wall rating legend for wall types and symbols

TABLE "A" WORKING CLEARANCES			
VOLTAGE TO GROUND	CONDITION: 1	2	3
(Normal)	(MINIMUM CLEAR DISTANCE)		
0-150	3'	3'	3'
151-600	3'	3 1/2'	4'

Where the "conditions" are as follows:

- Exposed live parts on one side and no live or grounded parts on the other side of the working space, or exposed live parts on both sides effectively guarded by suitable wood or other insulating materials, insulated wire or insulated busbars operating at not over 300 volts shall not be considered live parts.
- Exposed live parts on one side and grounded parts on the other side.
- Exposed live parts on both sides of the work space (Not guarded as provided in condition 1) with the operator between.

**NOTES:**

- This figure illustrates the working space in front of electrical equipment required by NEC section 110-26.
- This includes but is not limited to panel boards, safety switches, motor starters, junction boxes and other electrical equipment.

6 1/2" MINIMUM OR HEIGHT OF EQUIPMENT

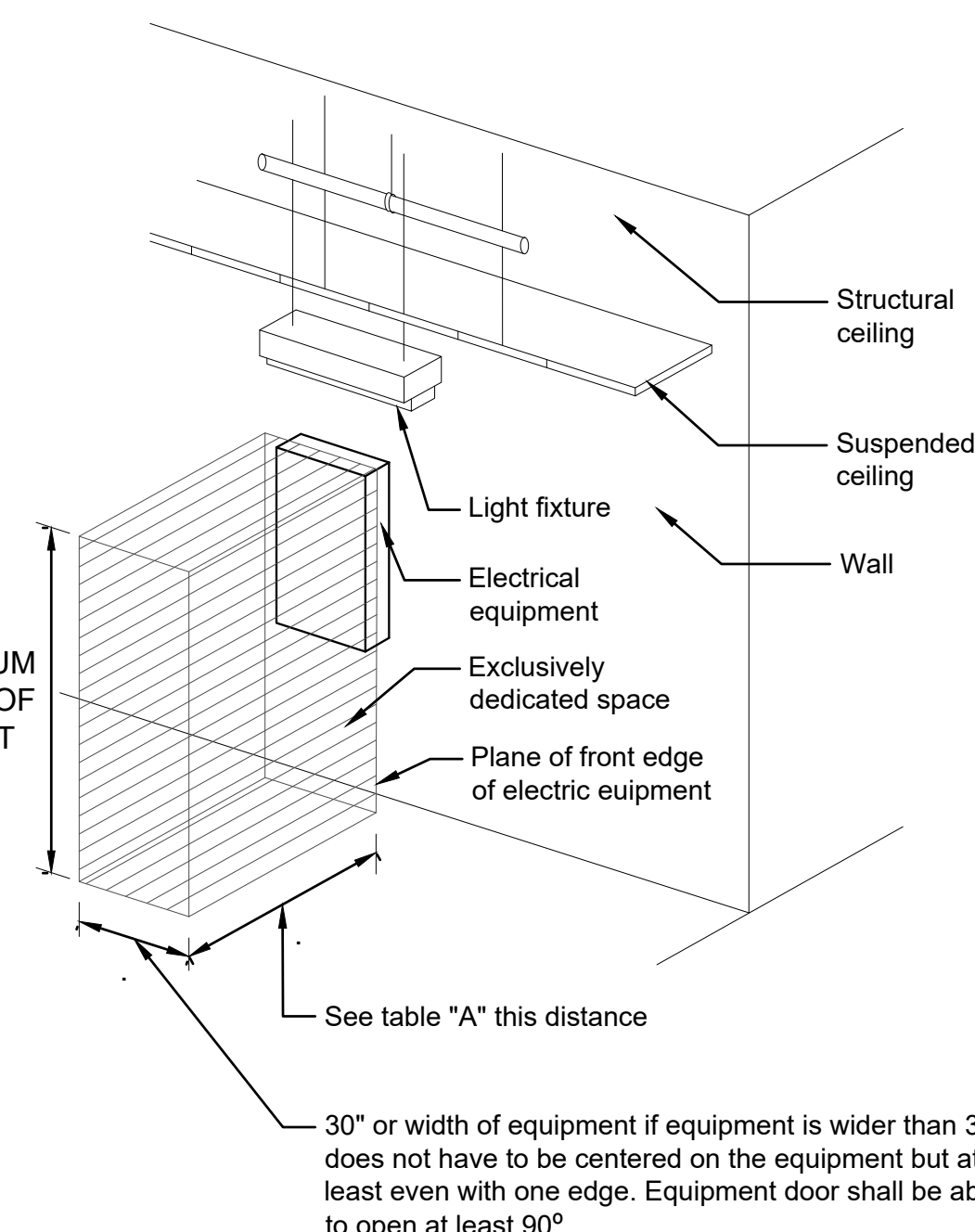

## NEC Article 110.26 Working Clearance For Electrical Equipment

2

Scale: None

**System No. W-L-1054**

ANSI/UL1479 (ASTM E814)	CANULC S115
F Ratings — 1 and 2 Hr (See Items 1 and 3)	F Ratings — 1 and 2 Hr (See Items 1 and 3)
T Rating — 0 Hr	FT Rating — 0 Hr
L Rating (Without Movement) at Ambient — Less Than 1 CFM/sq ft	FH Ratings — 1 and 2 Hr (See Items 1 and 3)
L Rating (Without Movement) at 400°F — Less Than 1 CFM/sq ft	FTH Rating — 0 Hr
M Rating (Movement) — See Table 1	FTH Rating — 0 Hr
	L Rating at Ambient — Less Than 5.1 L/sq/m <sup>2</sup>
	L Rating at 204°C — Less Than 5.1 L/sq/m <sup>2</sup>

**1. Wall Assembly** — The 1 or 2 hr fire-rated gypsum wallboard/stud wall assembly shall be constructed of the materials and in the manner specified in the individual U300 or U400 Series Wall and Partition Designs in the UL Fire Resistance Directory and shall include the following construction features:

A. Studs — Wall framing may consist of either wood studs or steel channel studs. Wood studs to consist of nom 2 by 4 in. (51 by 102 mm) lumber spaced 16 in. (406 mm) OC. Steel studs to be min 2-1/2 in. (64 mm) wide and spaced max 24 in. (610 mm) OC. For M Rating, steel studs to be min 3-5/8 in. (92 mm) wide. When steel studs are used and the diam of opening exceeds the width of stud cavity, the opening shall be framed on all sides using lengths of steel stud installed between the vertical studs and screw-attached to the steel studs at each end. The framed opening in the wall shall be 4 to 6 in. (102 to 152 mm) wider and 4 to 6 in. (102 to 152 mm) higher than the diam of the penetrating item such that, when the penetrating item is installed in the opening, a 2 to 3 in. (51 to 76 mm) clearance is present between the penetrating item and the framing on all four sides.

B. Gypsum Board — 5/8 in. (16 mm) thick, 4 ft (122 cm) wide with square or tapered edges. The gypsum board type, thickness, number of layers, fastener type and sheet orientation shall be as specified in the individual U300 or U400 Series Design in the UL Fire Resistance Directory. Max diam of opening is 32-1/4 in. (819 mm) for steel stud walls. Max diam of opening is 14-1/2 in. (368 mm) for wood stud walls. The F and FH Ratings of the firestop system are equal to the fire rating of the wall assembly. The M Rating is applicable only to 1 hr rated walls.

2. Through-Penetrants — One metallic pipe, conduit or tubing to be installed either concentrically or eccentrically within the firestop system. The annular space shall be min 0 in. to max 2-1/4 in. (57 mm). Pipe may be installed with continuous point contact. Pipe, conduit or tubing to be rigidly supported on both sides of wall assembly. The following types and sizes of metallic pipes, conduits or tubing may be used:

A. Steel Pipe — Nom 30 in. (762 mm) diam (or smaller) Schedule 10 (or heavier) steel pipe.

B. Iron Pipe — Nom 30 in. (762 mm) diam (or smaller) cast or ductile iron pipe.

C. Conduit — Nom 4 in. (102 mm) diam (or smaller) steel electrical metallic tubing or 6 in. (152 mm) diam steel conduit.

D. Copper Tubing — Nom 6 in. (152 mm) diam (or smaller) Type L (or heavier) copper tubing.

E. Copper Pipe — Nom 6 in. (152 mm) diam (or smaller) regular (or heavier) copper pipe.

3. Fill, Void or Cavity Material — Sealant — Min 5/8 in. (16 mm) thickness of fill material applied within the annulus, flush with both surfaces of wall. At the point or continuous contact locations between pipe and wall, a min 1/2 in. (13 mm) diam bead of fill material shall be applied at the pipe wall interface on both surfaces of wall.

HILTI CONSTRUCTION CHEMICALS, DIV OF HILTI INC — FS-ONE MAX Intumescent Sealant

Movement Direction	Penetrant Item	Nominal Penetrant Diameter	Annular Space	Movement	Sealant Depth	F-Rating	L Rating with Movement
Y	2A, 2C*	2 in.	Max 2-1/4 in.	5%	5/8 in.	1 hr	N/A
Z	2A, 2C*	2 in.	2-1/4 in.	0.25 in.	5/8 in.	1 hr	N/A

\* Indicates such products shall bear the UL or cUL Certification Mark for jurisdictions employing the UL or cUL Certification (such as Canada), respectively.

**HILTI Firestop Systems**

Reproduced by HILTI, Inc. Courtesy of Underwriters Laboratories, Inc. January 21, 2020

## Gypsum Framed Walls 1 or 2 Hour Penetration Firestop Metallic Pipe, Conduit, or Tubing

1

Scale: None

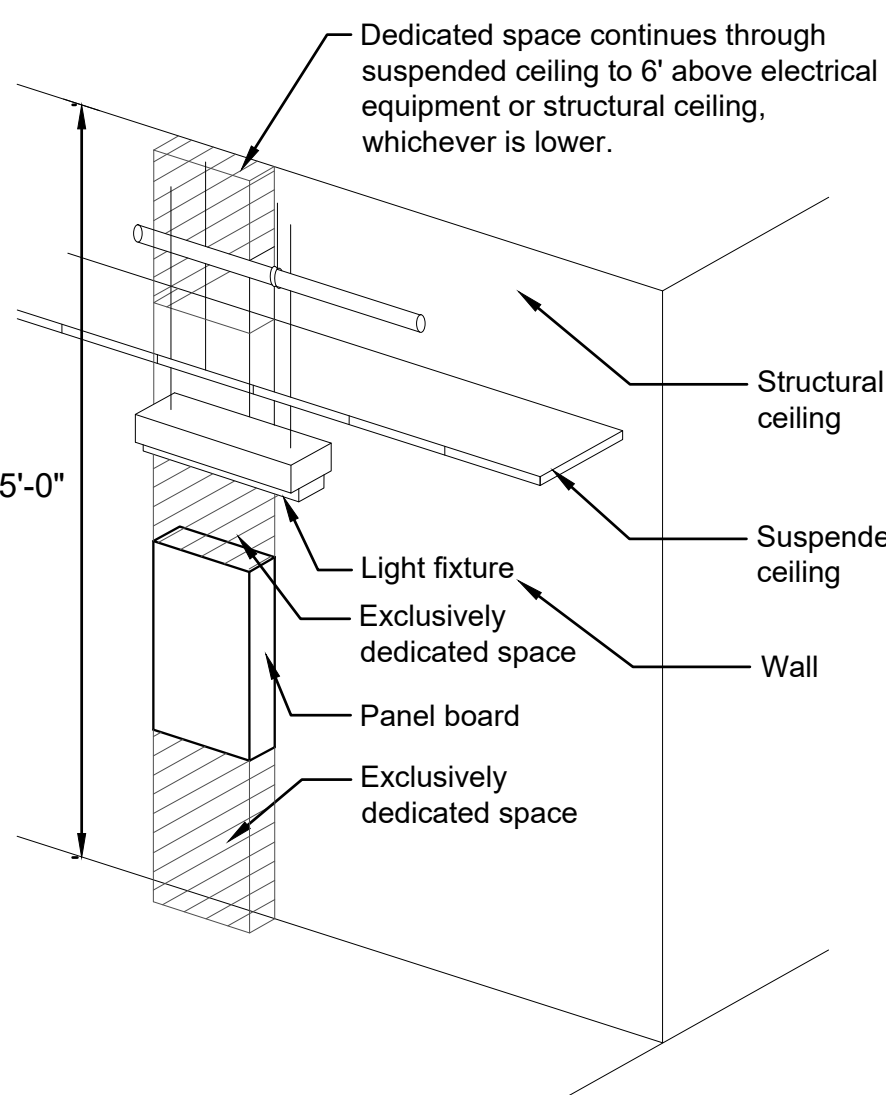

**NOTES:**

- This figure illustrates the additional exclusively dedicated space required over and under panel boards for cables, raceways, etc. to and from panel boards required by NEC section 110-26.
- No piping ductwork or equipment foreign to the electrical equipment or architectural appurtenances shall be permitted to be installed in, enter or pass through the dedicated spaces shown. For exceptions see NEC section 110-26(E).

## NEC Article 110.26 (E) Dedicated Equipment Space For Electrical Equipment

3

Scale: None

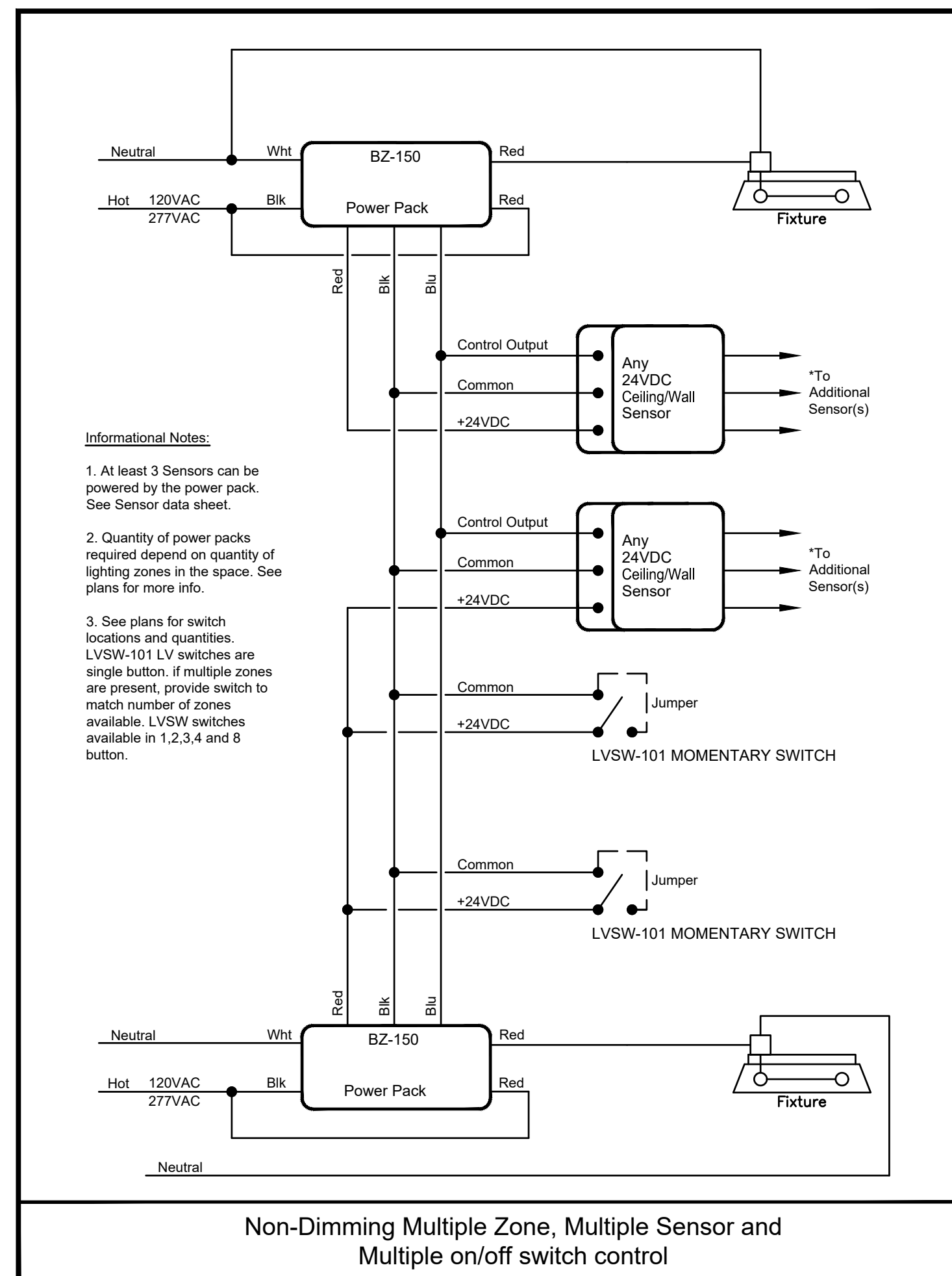

Non-Dimming Multiple Zone, Multiple Sensor and Multiple on/off switch control

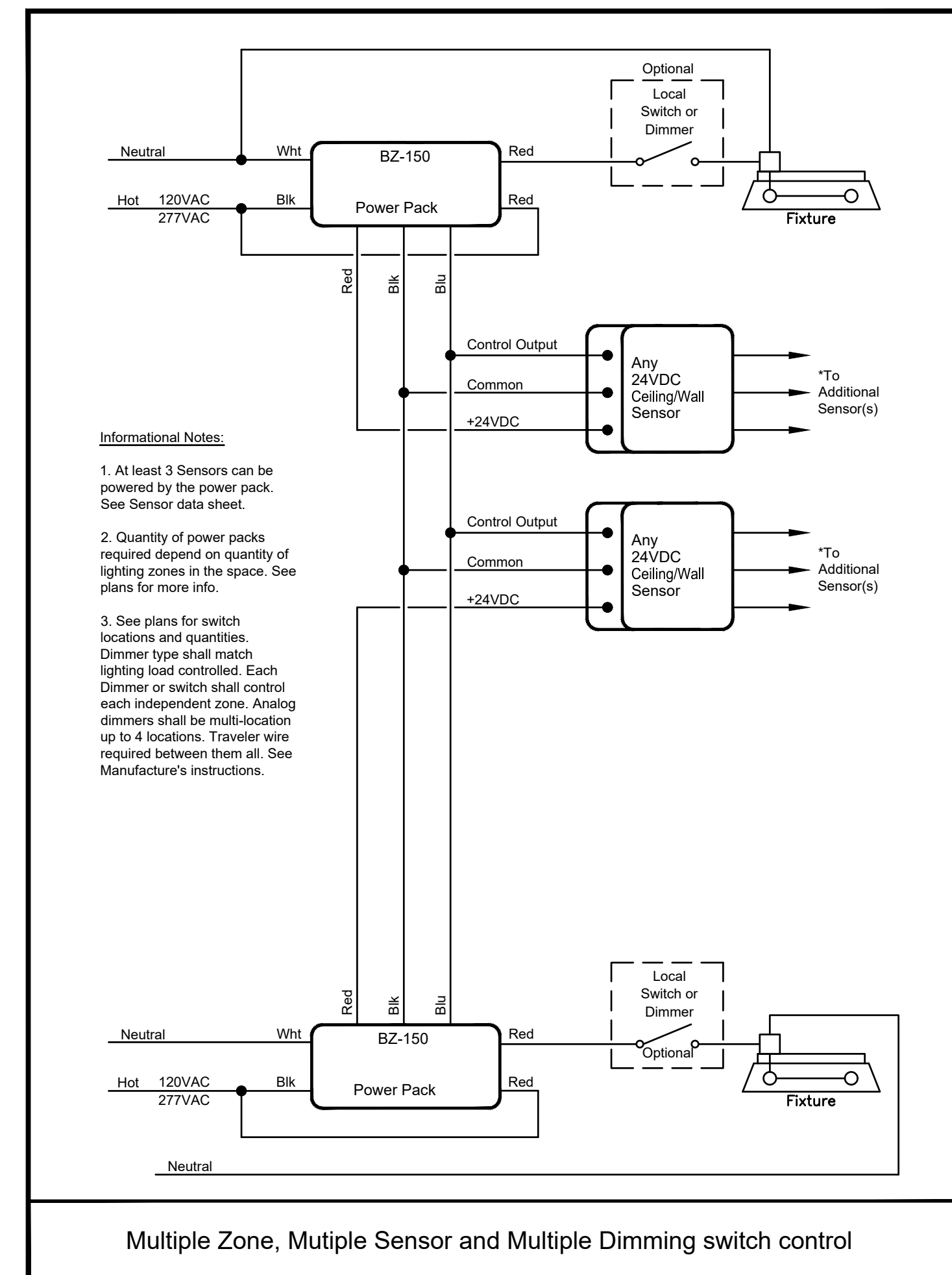

Multiple Zone, Multiple Sensor and Multiple Dimming switch control

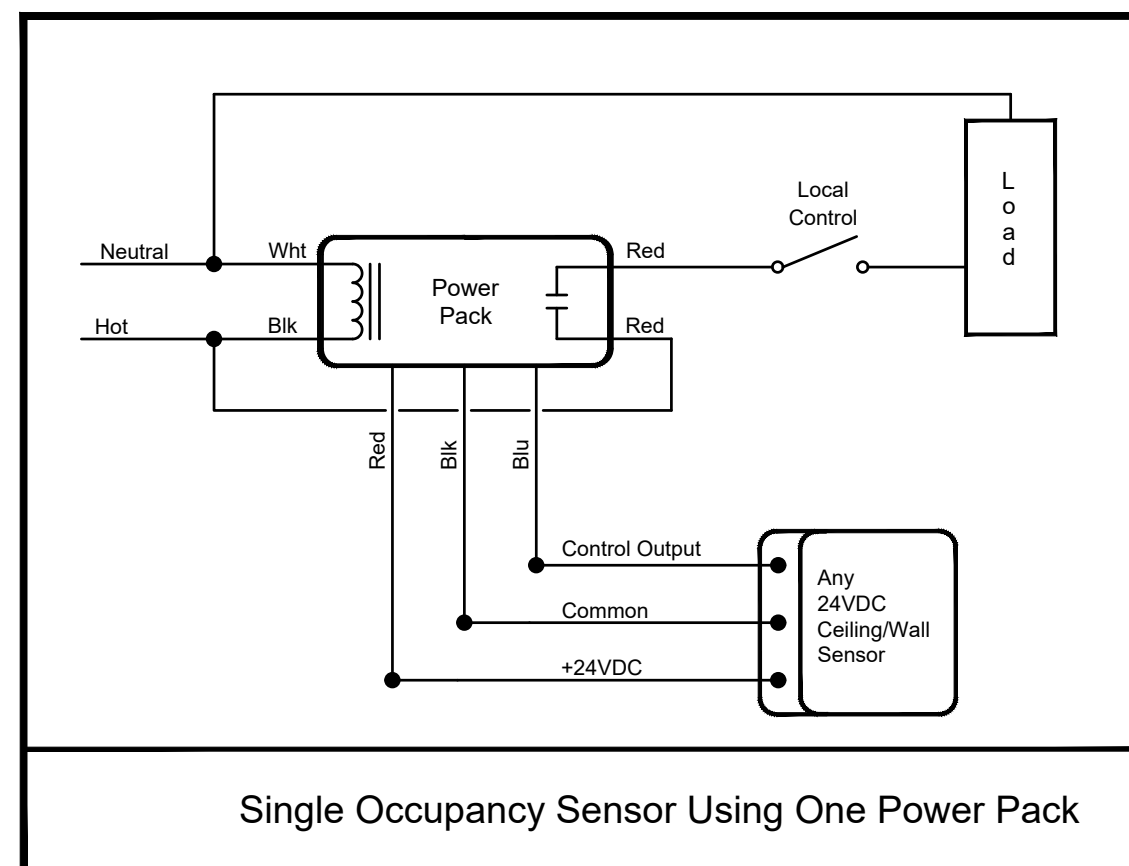

Single Occupancy Sensor Using One Power Pack

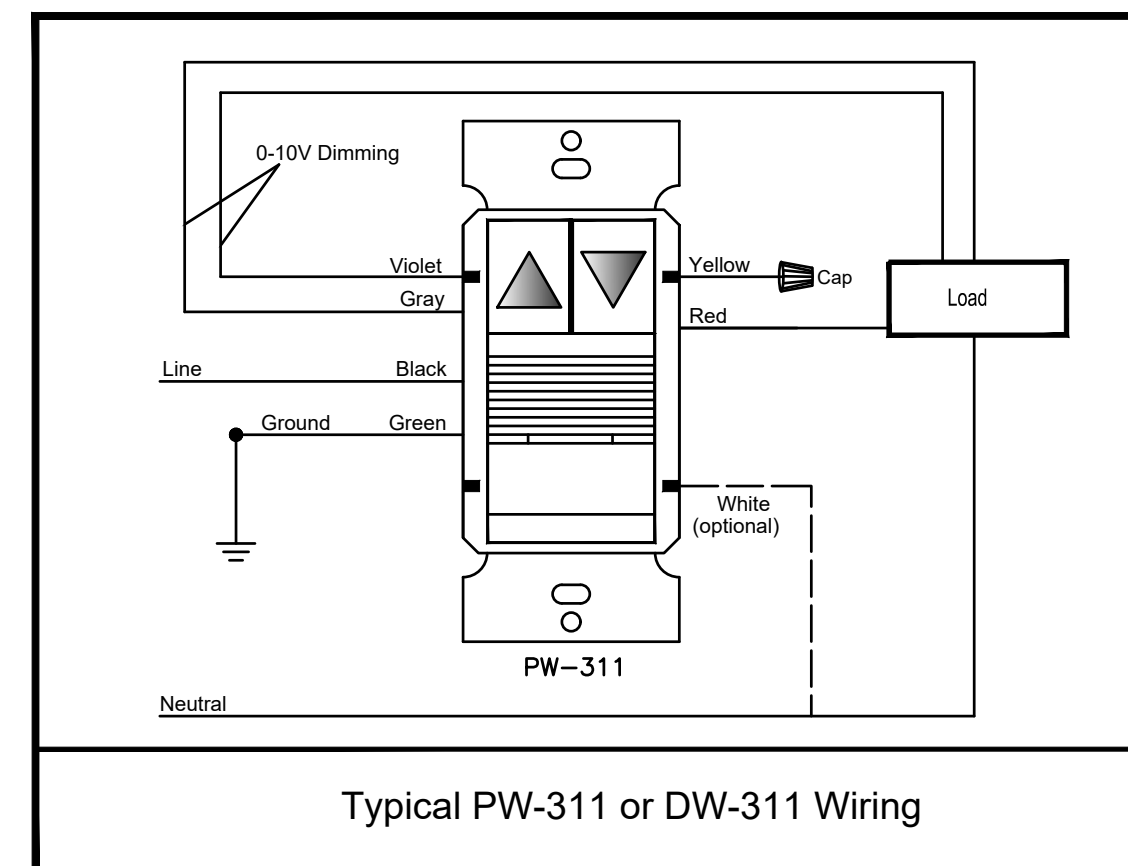

Typical PW-311 or DW-311 Wiring

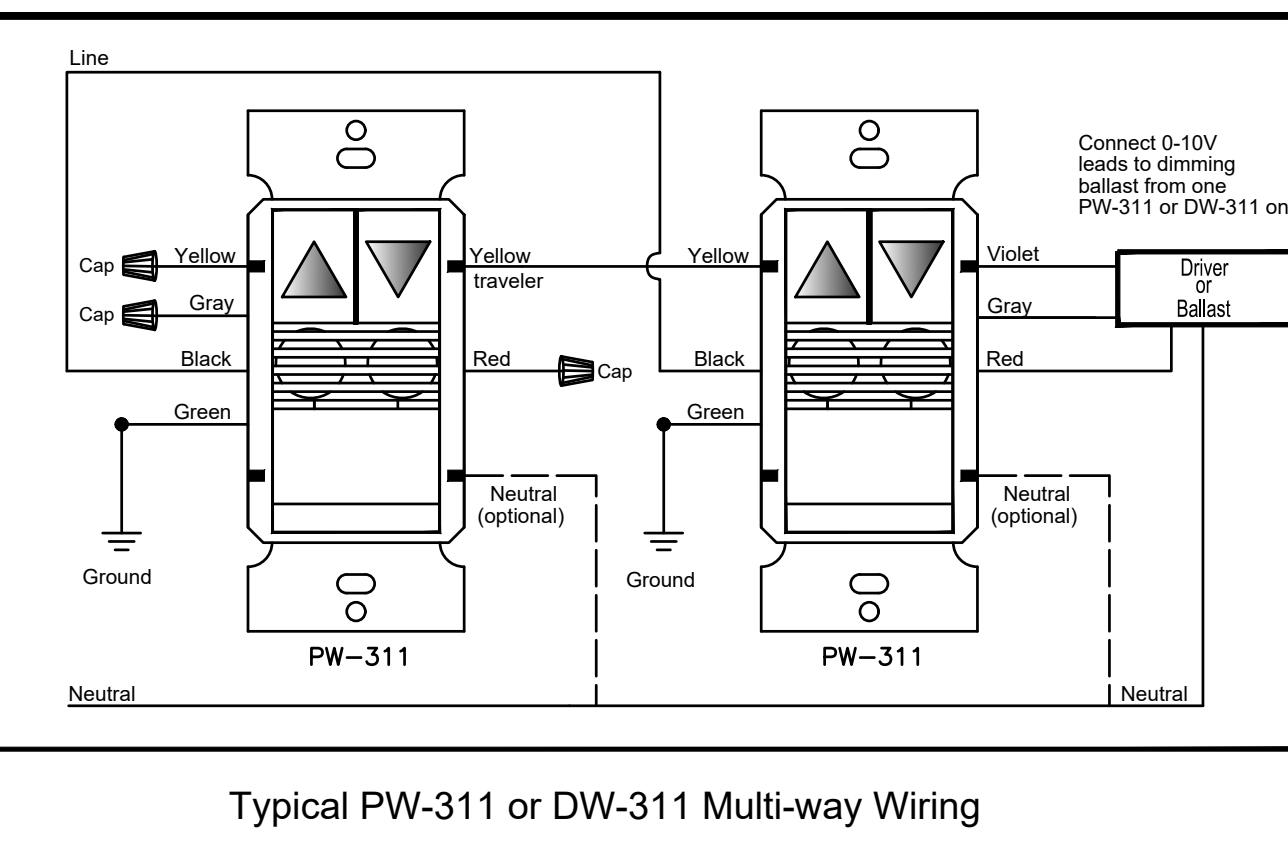

Typical PW-311 or DW-311 Multi-way Wiring

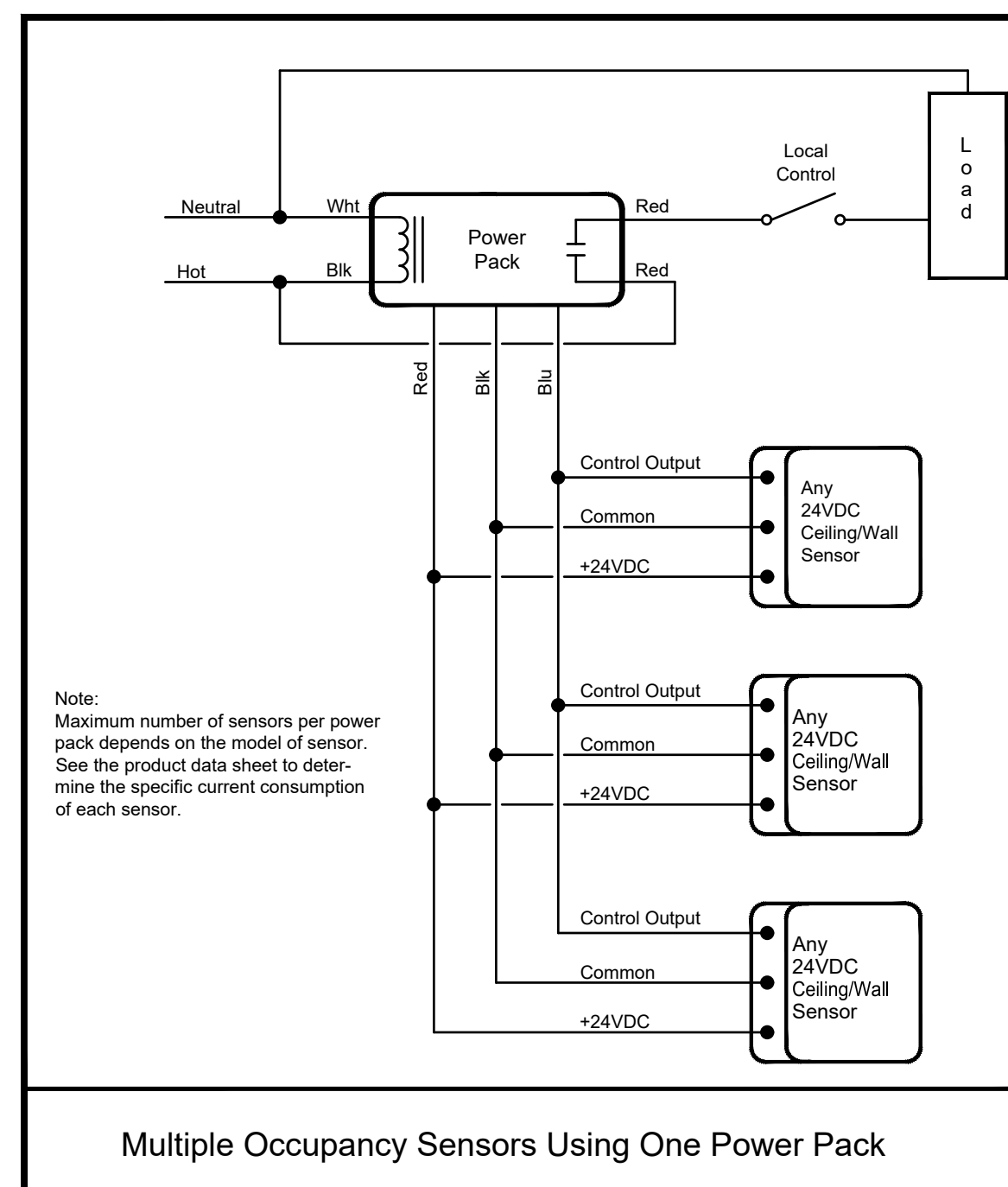

Multiple Occupancy Sensors Using One Power Pack

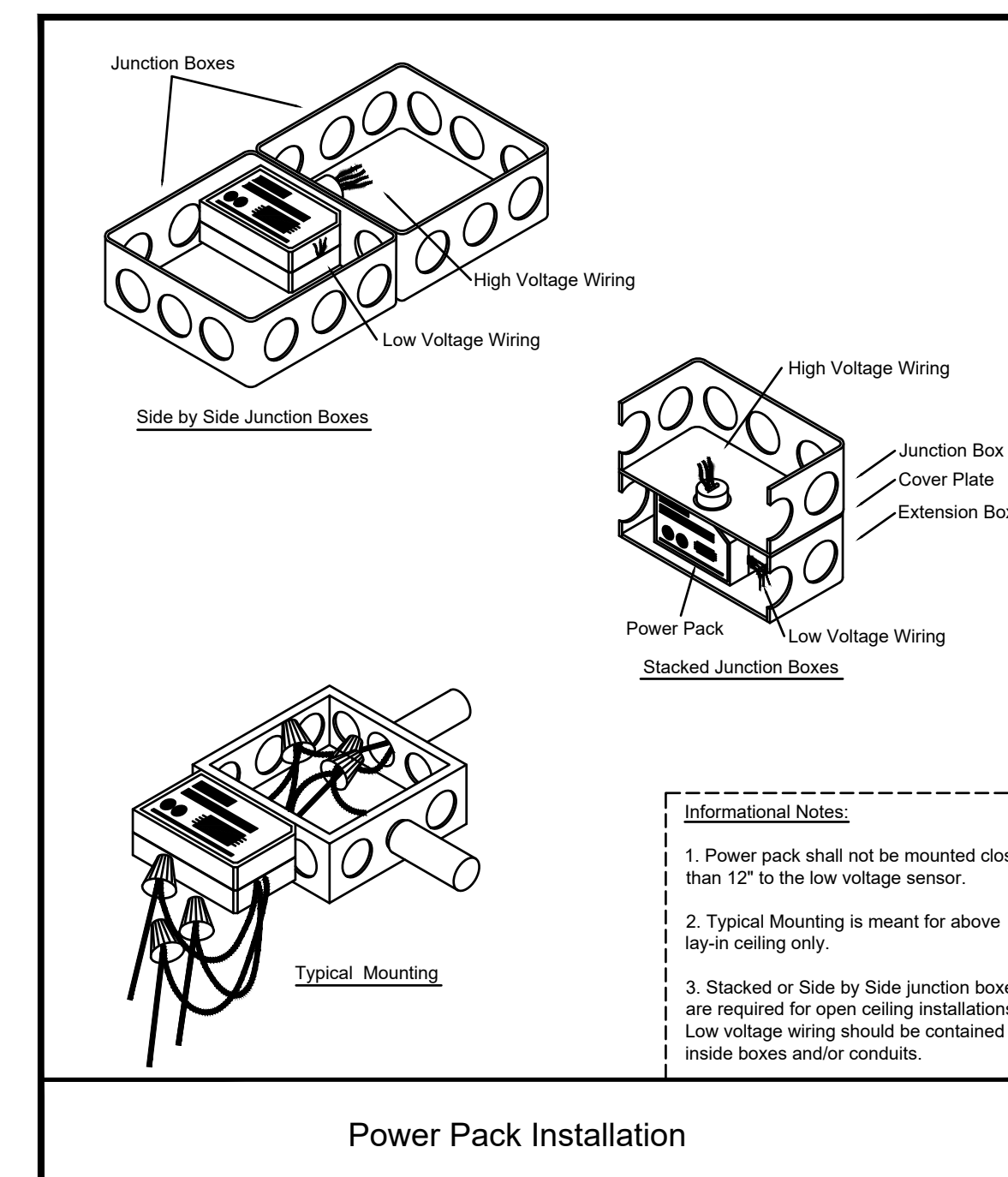

Power Pack Installation



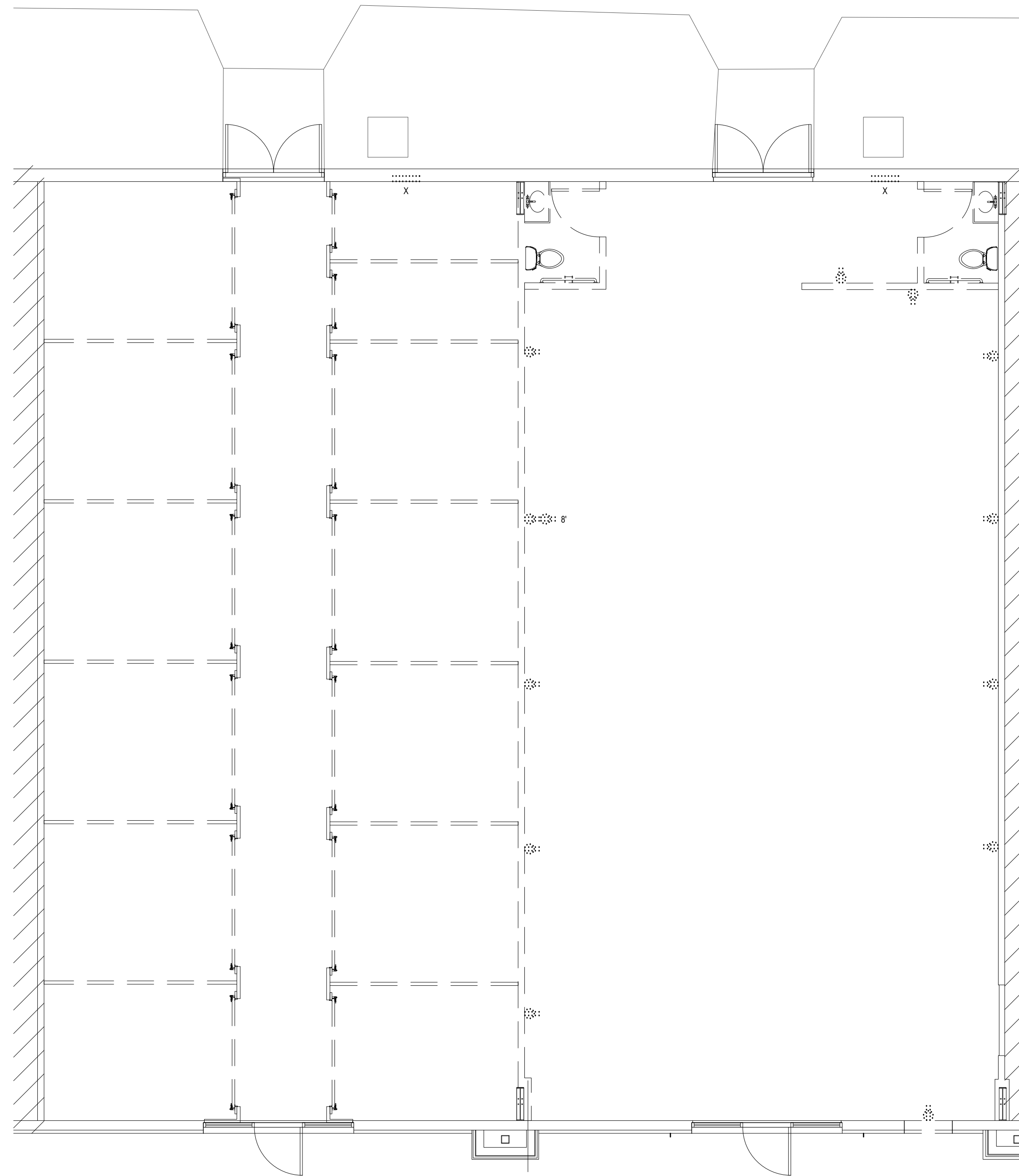

**1 Floor Plan - Demolition Power**  
Scale: 3/16" = 1' - 0"

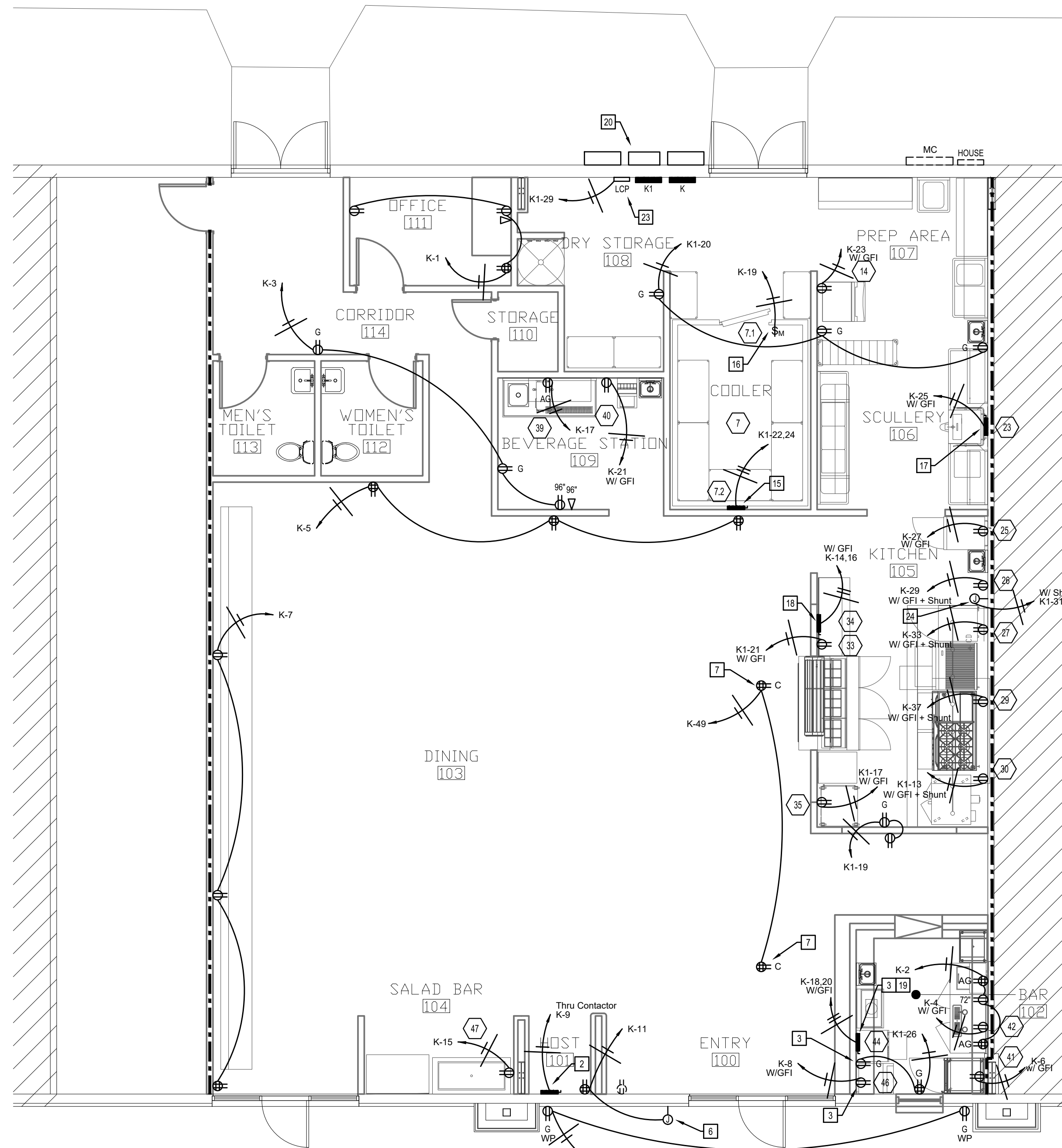

**2 Floor Plan - Power**  
Scale: 3/16" = 1' - 0"

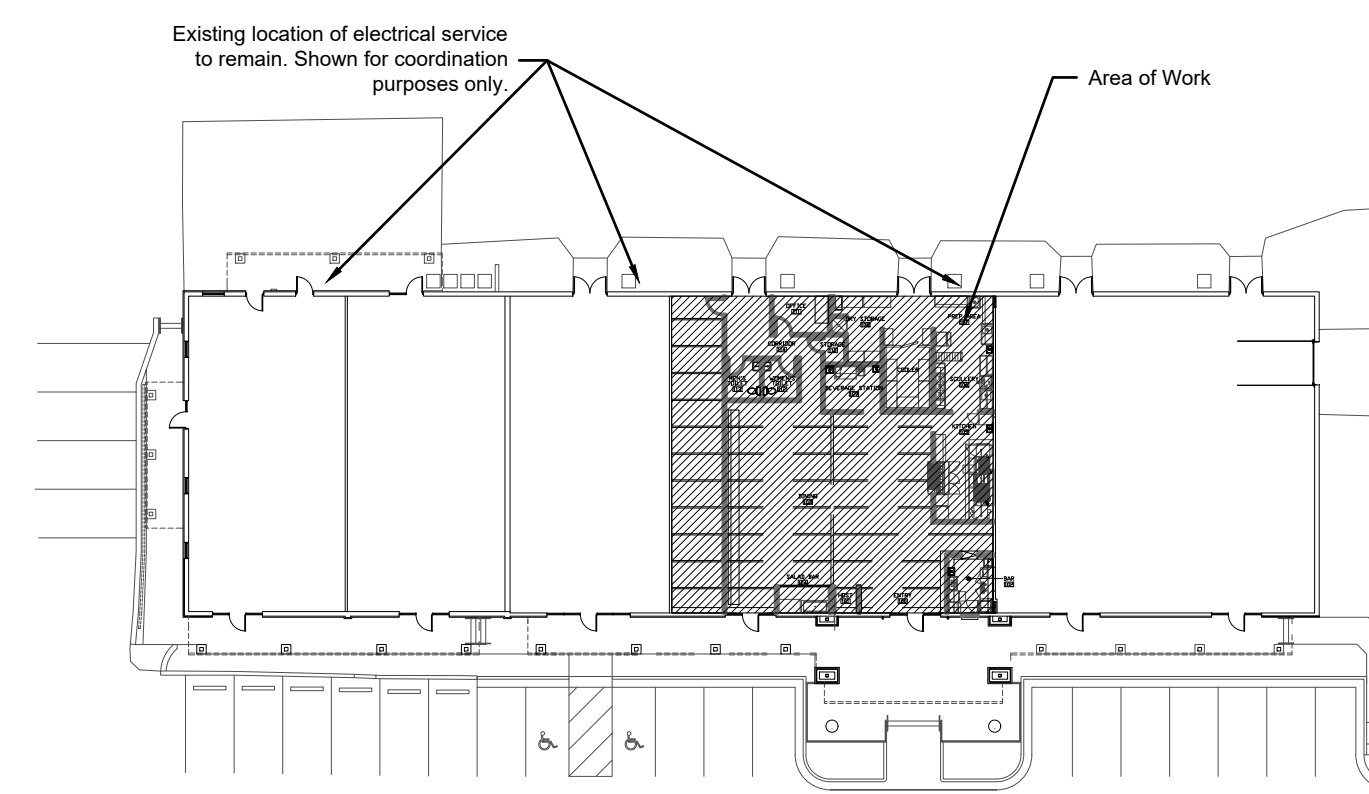

**3 Key Plan**  
Scale: None

**Sheet Notes:**

- All electrical boxes mounted in rated walls shall comply with all requirements of the 2018 NCSBC, section 714.3.2. All electrical boxes mounted in rated ceilings/horizontal assemblies shall comply with all requirements of the 2018 NCSBC, section 714.4.2. Devices shown in rated assemblies shall be flush with conduit concealed, unless otherwise indicated. Provide rated boxes, horizontal separation, putty pads, etc. as required for proper installation. Low voltage electrical devices mounted in rated assemblies shall be protected in accordance with the sections listed above as well.
- Individual branch circuits are shown with a dedicated neutral unless otherwise noted. When multi-wire branch circuits are to be installed, provide multi-pole circuit breakers as required. NEC 210.7
- See voltage drop schedule for wire sizing information for all branch circuits over 65' in length.
- All receptacles within 6 feet from the outside edge of any sink shall be GFCI. NEC 210.8(B)(5). All GFCI trip-reset receptacles shall be readily accessible. NEC 210.8.

**Plan Notes:** (All notes not used on all sheets)

- WP GFI receptacle on roof for maintenance. Connect as required. Coordinate exact locations with mechanical.
- Provide lockable 30/1 disconnect fused at 20 amps up high on wall for sign circuit per NEC 600.5. Connect as required.
- Mount device in millwork. Coordinate exact location and requirements with architect/millwork contractor prior to rough-in.
- Connect exhaust fan controlled by switch as required. Coordinate with mechanical.
- Connect gas water heater as required. Coordinate with plumbing.
- Junction box for illuminated menu holder. Coordinate exact location and requirements with Owner prior to rough-in. Connect as required.
- Ceiling mounted receptacles for decor. Coordinate exact location with Owner prior to rough-in. Connect as required.
- Connect air handler as required. Coordinate with mechanical.
- Connect heat pump as required. Coordinate with mechanical.
- Connect hood controls and lighting circuit as required. Coordinate requirements with equipment supplier.
- To hood supply fan, located on roof. Connect as required. Coordinate requirements with equipment supplier and mechanical contractor.
- To hood exhaust fan, located on roof. Connect as required. Coordinate requirements with equipment supplier and mechanical contractor.
- Provide receptacle for fly fan. Coordinate exact location with owner/mechanical contractor and connect as required.
- To kitchen hood controller. Connect as required. Coordinate requirements and exact location with equipment supplier.
- Connect walk-in condenser as required. Coordinate exact location and requirements with equipment supplier.
- Connect walk-in lights, controls, and defrost (if applicable) Coordinate exact location and requirements with equipment supplier.
- Connect dish machine as required. Coordinate exact location and requirements with equipment supplier.
- Connect heat lamp as required. Coordinate exact location and requirements with requirements with equipment supplier.
- Connect under counter glass washer as required. Coordinate exact location and requirements with equipment supplier.
- New electrical service. See Riser Diagram.
- Connect to circuit K1-5' with other WP GFI receptacle for maintenance as required.
- Connect booster pump as required. Coordinate with plumbing.
- Connect lighting control panel as required. Coordinate exact location with Owner before beginning work.
- Junction box for gas solenoid valve. Coordinate location and requirements with mechanical. Connect as required.

**Kitchen Notes:**

- See kitchen equipment shop drawings and kitchen equipment schedule for all device locations, mounting heights, etc. Verify all kitchen equipment requirements, locations, connection types, etc. with kitchen equipment supplier and/or kitchen equipment manufacturer's literature prior to rough-in. Do not install any kitchen equipment connections until approved kitchen equipment shop drawings have been received.
- Coordinate all kitchen equipment connection requirements with equipment supplier. Provide cord and plug where necessary. All final connections between outlet, motor switch, junction box, or disconnect to equipment shall be by the electrical contractor. Connections to equipment shall provide the complete and working system to allow the equipment to operate as intended.
- Seal any and all penetrations through walk-in cooler/freezer as required per NEC 300.7
- All 120V and 208V receptacles in kitchen and food prep areas shall be GFCI protected per NEC 210.8.
- All light fixtures mounted over food prep, cooking, serving areas shall have an approved lens.
- Connect hood fire suppression system as required. Coordinate with equipment supplier.
- Connect fire suppression system to gas solenoid and shunt trip breakers as required. Activation of the fire suppression system shall de-energize electrical equipment under hoods and close gas valve.

**Demo Note:**

The existing locations shown on demo plan to be removed or relocated are for reference only and shall be field verified by contractor prior to beginning work. Any items required to be removed or relocated shall be included in contractor's cost, whether shown on this plan or not. Unless noted otherwise, where a device or fixture is noted to be demolished, the work shall include removing all associated boxes, conduits, hangers, conductors, cables etc. and shall include any patch, repair, paint or refinishing necessary to restore the location to match the surroundings. The contractor may reuse any existing conductors, boxes etc. where they have been inspected and are determined to be acceptable to the owner and/or in like-new condition.

**Wall Ratings and Types Legend**

See architectural sheets for more information on ratings and additional rated constructions including structure where applicable. Protect all rated constructions as required.

Existing Wall to Remain	_____
New Wall being Constructed	_____
One Hour Fire Barrier	_____
Existing Wall being Demolished	_____





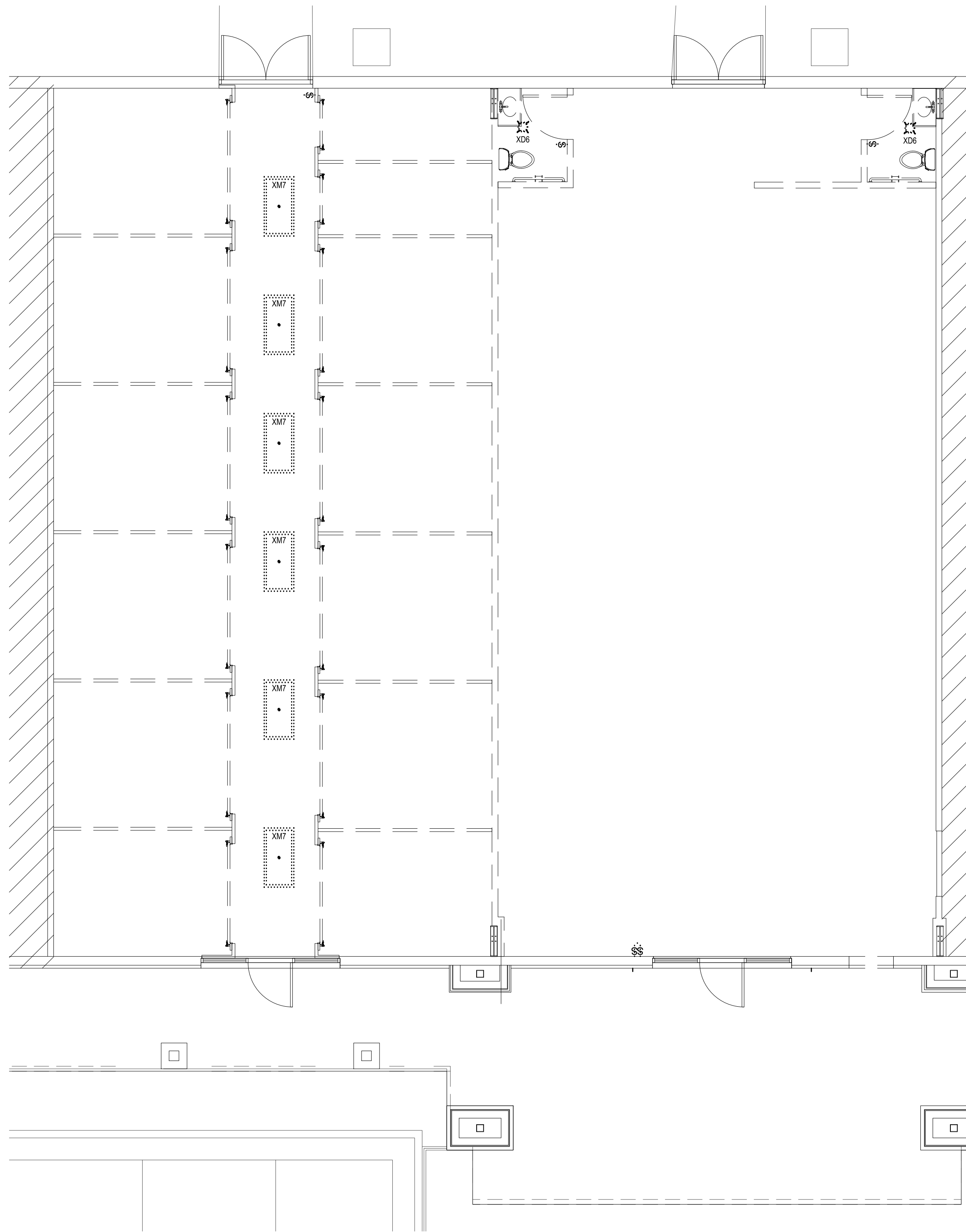

**1** Floor Plan - Demolition Lighting  
Scale: 3/16" = 1' - 0"

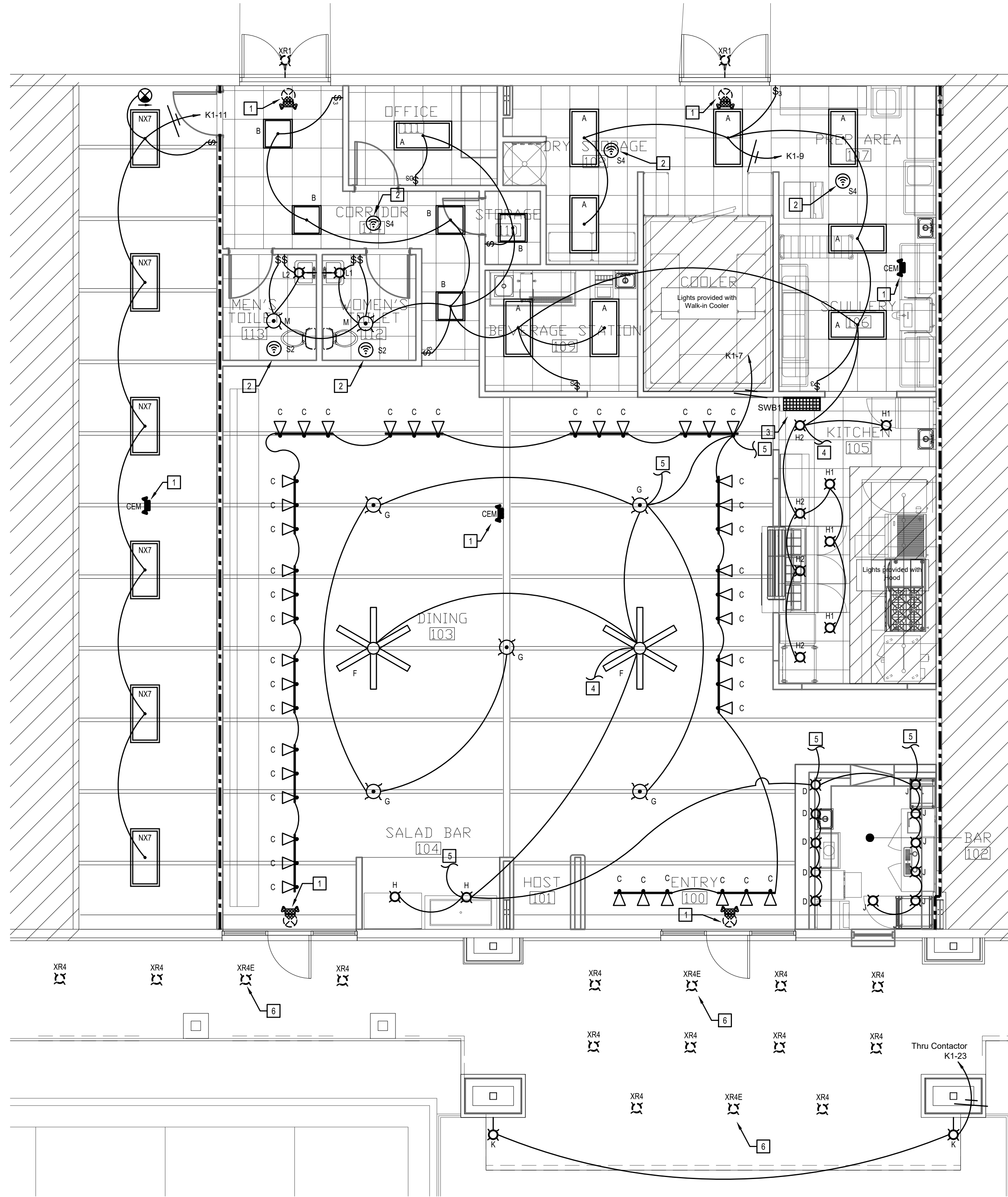

**2** Floor Plan - Lighting  
Scale: 3/16" = 1' - 0"

**Sheet Notes:**

- All electrical boxes mounted in rated walls shall comply with all requirements of the 2018 NCSCB, section 714.3.2. All electrical boxes mounted in rated ceilings/horizontal assemblies shall comply with all requirements of the 2018 NCSCB, section 714.4.2. Devices shown in rated assemblies shall be flush with conduit concealed, unless otherwise indicated. Provide rated boxes, horizontal separation, putty pads, etc. as required for proper installation. Low voltage electrical devices mounted in rated assemblies shall be protected in accordance with the sections listed above and well.
- Connect wall packs or other normally off emergency lights, exit signs and night lights ahead of local switches and/or controls. (total fixture unswitched). Where lights are not indicated as night lights, fixtures with emergency batteries shall be connected with the battery ahead of switch so that the emergency battery comes on only in the event of power loss. Fixture is normally controlled with the other lights under normal conditions.
- See motion sensor details for specifications and wiring details.
- Lighting controls including occupancy sensors, automatic time switches, automatic shut-off controls, or daylight/occupant sensing automatic controls, the electrical contractor shall be responsible for testing the lighting controls per section C408.3 of the 2018 NC Energy Conservation Code. Ensure that control devices, components, and systems are calibrated, adjusted and operate in accordance with the approved plans and/or specifications. Sequences of operation shall be functionally tested to ensure they operate in accordance with the approved plans and/or specifications.
- Individual branch circuits are shown with a dedicated neutral unless otherwise noted. When multi-wire branch circuits are to be installed, provide multi-pole circuit breakers as required. NEC 210.7
- See voltage drop schedule for wire sizing information for all branch circuits over 65' in length.
- Contractor may reuse existing emergency/ exit light, given that the device is in proper working order and it matches the established standard for the space. Replace chevrons and rotate as shown on plans.

**Plan Notes:**

- Connect emergency and exit lights ahead of local switch/controls so that total fixture is unswitched. Connect as required.
- Motion sensor to control all lights in this room. See motion sensor wiring diagrams. Provide required power packs to control all lights with override off switches as shown.
- Switchbank 1 consist of 2 single pole and 6 dimmer switches. Provide engraved labeling for each switch and do not gang more than 8 switches together. Connect as required.
- To Single Pole switch in Switchbank 1. Connect as required.
- To Dimmer switch in Switchbank 1. Connect as required.
- Confirm existing emergency light is connect such that it is illuminated upon loss of power.

**Demo Note:**

The existing locations shown on demo plan to be removed or relocated are for reference only and shall be field verified by contractor prior to beginning work. Any items required to be removed or relocated shall be included in contractor's cost, whether shown on this plan or not. Unless noted otherwise, where a device or fixture is noted to be demolished, the work shall include removing all associated boxes, conduits, hangers, conductors, cables etc. and shall include any patch, repair, paint or refinishing necessary to restore the location to match the surroundings. The contractor may reuse any existing conductors, boxes etc. where they have been inspected and are determined to be acceptable to the owner and/or in like-new condition.

Wall Ratings and Types Legend	
See architectural sheets for more information on ratings and additional rated constructions including structure where applicable. Protect all rated constructions as required.	
Existing Wall to Remain	_____
New Wall being Constructed	_____
One Hour Fire Barrier	_____
Existing Wall being Demolished	_____



Demand Loads Panel K1		
Load Type		Load
Lights (@ 125%)		2.4 KVA
Receptacles and Miscellaneous		5.0 KVA
Kitchen Equipment (Calculated per NEC 220.54)		4.6 KVA
Gas Water Heaters		1.0 KVA
Air Handling Units		13.9 KVA
Tracking Lighting (Calculated Per NEC 410.151(B))		4.2 KVA
Fans		5.4 KVA
	Total:	36.5 KVA
152.1 AMPS @ 240V/1Ø		

**Panel: K1**  
 Voltage: 120/240  
 Poles: 42  
 Phase: 1  
 Wires: 3  
 Main Type: Main Lugs Only  
 Main Rating: 300 Amps  
 Fed From: Utility  
 Manufacture: Square D NQOB  
 Mounting: Surface

Load Type	kVA	Breaker Size	Ø	Breaker Size	kVA	Load Type
GMVHs	0.5	20/1	1 A	2	6/02	6.9
GVH	0.5	20/1	3 B	4		7.0
Roof W/P/GFI Rec.	0.2	20/1	5 A	6	15/2	1.2
Lights	1.0	20/1	7 B	8		1.2
Lights	0.7	20/1	9 A	10	20/1	-
Lights	0.6	20/1	11 B	12	20/2	1.5
Gas Convection Oven	0.9	20/1 (G)	13 A	14		1.5
Shunt Trip	-	-	15 B	16	20/1	-
Heated Holding Cabinet	1.9	20/1 (G)	17 A	18	15/1	0.5
Conv. Recs.	0.4	20/1	19 B	20	20/1	0.6
Refrigerator	0.7	20/1 (G)	21 A	22	20/2	1.6
Exterior Lights	0.1	20/1	23 B	24		1.5
Booster Pump	1.2	20/2	25 A	26	20/1	0.4
LCP	0.5	20/1	27 B	28	-	-
Gas Solenoid Valve	0.5	20/1	31 B	32	-	-
Space	-	-	33 A	34	-	-
Space	-	-	35 B	36	-	-
Space	-	-	37 A	38	-	-
Space	-	-	39 B	40	-	-
Space	-	-	41 A	42	-	-

**Demand Load Summary:**

Lighting: 2.3 kVA @ 125%	2.9 kVA	Phase A: 16.9 kVA	141.0 Amps
Largest Motor: kVA @ 125%	kVA	Phase B: 16.0 kVA	133.1 Amps
Gen Receptacles: 1.6 kVA @ 100%	1.6 kVA		
Kitchen Equipment: 7.1 kVA Diversified	4.6 kVA	Total Panel Load: 32.9 kVA	137.0 Amps
All Other: 23.8 kVA @ 100%	23.8 kVA		

- UL SE rated
- Separate Neutral Bar
- Ground bar
- Feed thru lugs
- Existing Panel

- All breakers shall be 10,000 AIC and series rated to 42,000 AIC with fuse feeding this panel.
- Kitchen equipment diversification taken per NEC 220.54.

**Panel: K**  
 Voltage: 120/240  
 Poles: 42  
 Phase: 1  
 Wires: 3  
 Main Type: Main Lugs Only  
 Main Rating: 300 Amps  
 Fed From: Utility  
 Manufacture: Square D NQOB  
 Mounting: Surface

Load Type	kVA	Breaker Size	Ø	Breaker Size	kVA	Load Type
Office Recs.	0.8	20/1	1 A	2	20/1	1.0
Conv. Recs.	0.6	20/1	3 B	4	20/1	0.3
Dining Recs.	1.2	20/1	5 A	6	20/1	0.3
Dining Recs.	0.8	20/1	7 B	8	20/1	0.9
Sign Circuit	0.5	20/1	9 A	10	20/1	0.4
POS/Illuminate Menu	0.4	20/1	11 B	12	20/1	0.2
Exterior GFI Recs.	0.4	20/1	13 A	14	20/2 (G)	1.5
Cold Food Station	1.5	20/1	15 B	16		1.5
Coffee Brewer	1.7	20/1	17 A	18	45/2	4.0
Walk-In Cooler Lts./Door Heater	0.1	20/1	19 B	20		3.9
Beverage Dispenser	0.1	20/1 (G)	21 A	22	50/2	3.8
Ice Maker	1.2	20/1 (G)	23 B	24		3.9
Warewasher	1.9	20/1 (G)	25 A	26	40/2	3.1
Freezer	0.3	20/1 (G)	27 B	28		3.1
UC Refrigerator	0.3	20/1 (G)	29 A	30	40/2	3.1
Shunt Trip	-	-	31 B	32		3.1
Refrigerator Shorty	1.0	20/1 (G)	33 A	34	60/2	7.0
Shunt Trip	-	-	35 B	36		6.9
Gas Range	0.7	20/1 (G)	37 A	38	60/2	6.9
Shunt Trip	-	-	39 B	40		7.0
Spare	-	-	41 A	42	-	-

**Demand Load Summary:**

Lighting: kVA @ 125%	kVA	Phase A: 35.7 kVA	297.3 Amps
Largest Motor: kVA @ 125%	kVA	Phase B: 32.3 kVA	269.2 Amps
Gen Receptacles: 5.2 kVA @ 100%	5.2 kVA		
Kitchen Equipment: 21.2 kVA Diversified	13.8 kVA	Total Panel Load: 68.0 kVA	283.3 Amps
All Other: 49.0 kVA @ 100%	49.0 kVA		

- UL SE rated
- Separate Neutral Bar
- Ground bar
- Feed thru lugs
- Existing Panel

- All breakers shall be 10,000 AIC and series rated to 42,000 AIC with fuse feeding this panel.
- Kitchen equipment diversification taken per NEC 220.54.

**Panel Schedule Notes (All Panels, All Sheets):**

- All panel directories shall be completed in accordance with NEC 408.4.
- Values for demand loads include all code factors such as 125% for continuous loads, 125% largest motor, etc.
- Breaker sizes shown in panel schedules for new equipment are for reference only, see equipment connection schedule for additional information. Where breaker / fuse size between schedules conflict, the equipment connection schedule shall take precedence. Contractor shall ultimately confirm breaker size with equipment provider.
- Circuit breakers used as overcurrent protection for HVAC equipment shall be "HACR" type.
- Contractor shall provide identification for new feeders and any new branch circuits per NEC 200.6, 210.5, and 215.12.
- Contractor shall label breakers feeding emergency and exit lighting per NEC 700.12(F).
- Provide arc flash hazard warning labels as required on all panels affected by this work to comply with NEC 110.16.
- Where circuit breakers or fuses are noted to be series rated, the equipment shall be listed per NEC 110.22 as applicable. Tested series combination systems, the placard shall state the following "Caution - Series Combination System Rated \_\_\_\_\_ Amperes. Identified Replacement Components Required." See NEC 110.22(b), for engineered series combination systems placarding language.
- Contractor shall provide multiple breakers in place of all single pole breakers shown, when multiwire branch circuits are installed per NEC 210.4(B).
- Breakers indicated as (G) shall have GFCI protection provided. 20/1(G) means a 20 amp single pole breaker with GFCI protection.

**Electrical Riser Notes**

- Grounds for all services shall be bonded together per NEC 250.58 and shall meet all requirements of NEC 250.104.
- The design is based on an estimated fault current of 42,000. The contractor shall coordinate with the utility power company to confirm the available fault current at the transformer and service entrance conductor length. This information shall be submitted to engineer as part of the gear submittal, prior to beginning work.
- The service equipment enclosure(s) shall be legibly marked in the field to indicate the available fault current prior to final inspection, NEC 110.24. The electrical contractor shall contact the power company and obtain the actual available fault current at the transformer. The contractor shall contact the engineer with this value, the verified length of conductors run from the transformer to the service enclosure, as well as the conductor type for the calculation of the available fault current. The resulting calculated value shall be placarded on the exterior of the service enclosure and shall read as follows:  
  
 AVAILABLE FAULT CURRENT: \_\_\_\_\_  
 CALCULATED DATE: \_\_\_\_\_
- Provide plaques per NEC 230.2(E) and graphic key plans for each service and service disconnecting means for each building service. All disconnecting means for each service shall be grouped. Label each disconnecting means for each service as disconnect # \_\_\_\_\_ of 2 for service number # \_\_\_\_\_ of 3. Provide labeling and graphic key plan at main electrical panel (or panels) showing the location and identification of their disconnecting means.
- Where circuit breakers or fuses are applied in compliance with the series combination ratings marked on the equipment by the manufacturer, the equipment enclosure(s) shall be legibly marked in the field to indicate the equipment has been applied with a series combination rating. The placard shall be readily visible and state the following "CAUTION - SERIES COMBINATION SYSTEM RATED \_\_\_\_\_ AMPERES. IDENTIFIED REPLACEMENT COMPONENTS REQUIRED." NEC 110.22
- Contractor shall meet all requirements of NEC 250.50 for service grounding. Connect to structural steel, rebar, metal water piping and any other available at the structured served. See service ground detail for more information.

Demand Loads Panel K		
Load Type		Load
Receptacles and Miscellaneous		5.6 KVA
Heat Pumps (includes 125% factor for largest motor)		20.1 KVA
Air Handling Units		27.8 KVA
Fans		0.2 KVA
Sign Circuit		0.5 KVA
Kitchen Equipment (Calculate per NEC 220.54)		13.8 KVA
	Total:	68.0 KVA
283.3 AMPS @ 240V/1Ø		

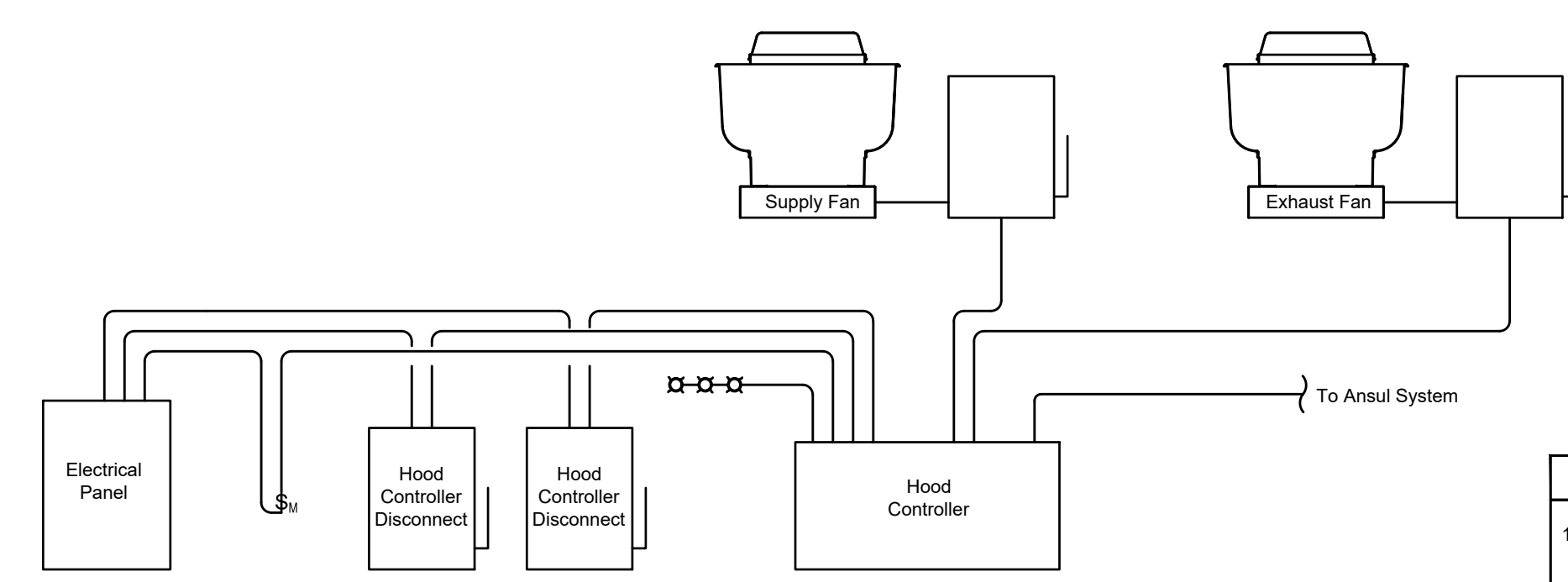

**Hood Notes:**

- Refer to hood drawings by kitchen equipment vendor or hood supplier for exact location of components and wiring requirements.
- See plans for locations for electrical panels, hood controller disconnects, switches, disconnects, etc. See equipment schedule for exact fan and controller disconnect, fuses, and wire sizing.

**1 Hood Wiring Diagram**  
 Scale: None

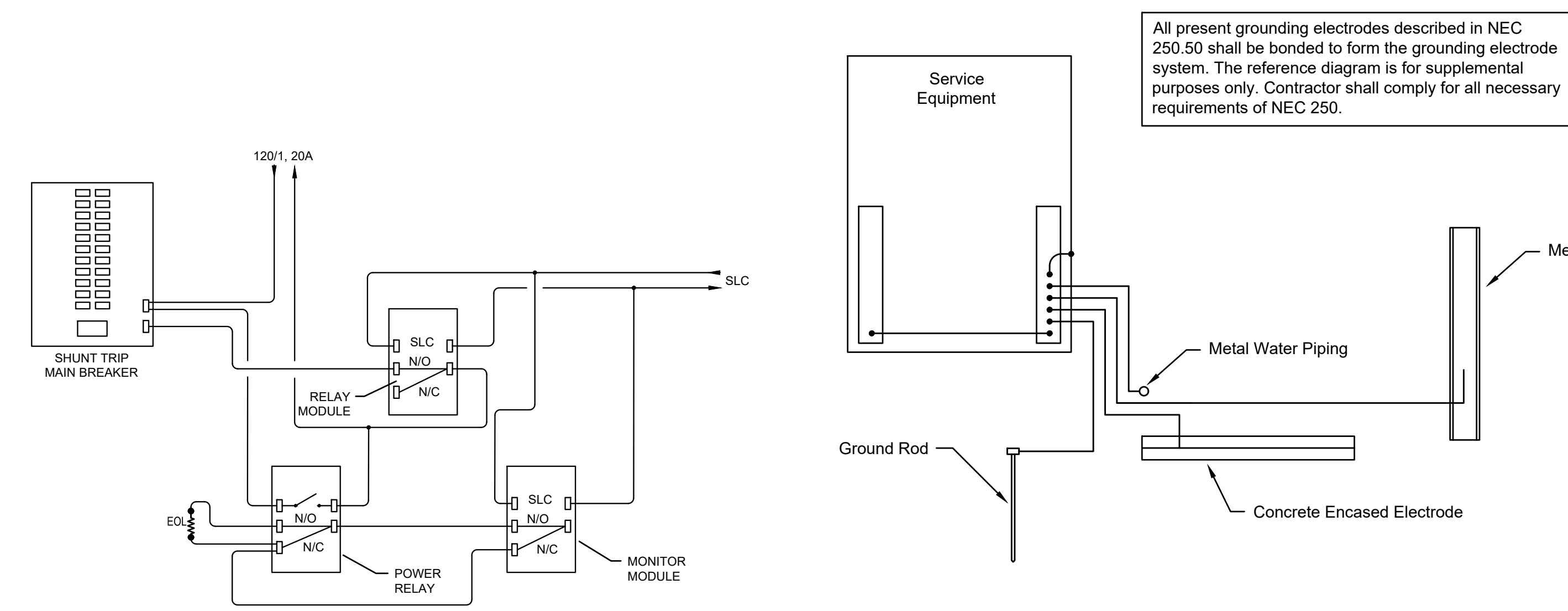

All present grounding electrodes described in NEC 250.50 shall be bonded to form the grounding electrode system. The reference diagram is for supplemental purposes only. Contractor shall comply for all necessary requirements of NEC 250.

**2 Shunt Trip Breaker Detail**  
 Scale: NTS

**3 Grounding Electrode System Detail**  
 Scale: None

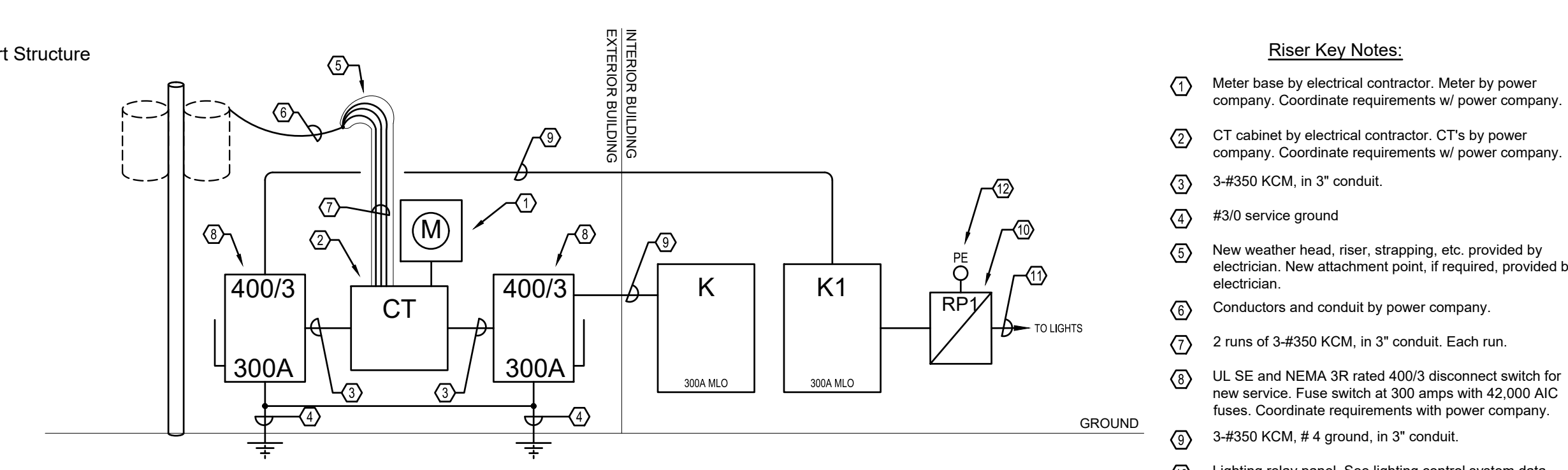

- Riser Key Notes:**
- Meter base by electrical contractor. Meter by power company. Coordinate requirements w/ power company.
  - CT cabinet by electrical contractor. CT's by power company. Coordinate requirements w/ power company.
  - 3-#350 KCM, in 3" conduit.
  - #3/0 service ground
  - New weather head, riser, strapping, etc. provided by electrician. New attachment point, if required, provided by electrician.
  - Conductors and conduit by power company.
  - 2 runs of 3-#350 KCM, in 3" conduit. Each run.
  - UL SE and NEMA 3R rated 400/3 disconnect switch for new service. Fuse switch at 300 amps with 42,000 AIC fuses. Coordinate requirements with power company.
  - 3-#350 KCM, # 4 ground, in 3" conduit.
  - Lighting relay panel. See lighting control system data riser diagram for specifications.
  - Circuits as specified on plans. All tenant lighting loads shall be connected thru lighting control system.
  - Photocell on roof facing north. Adjust sensitivity as required for proper operation.

**4 Electrical Riser Diagram**  
 Scale: None

**i-design**  
 ARCHITECTURE + INTERIORS  
 1111 Hayes Street, Suite 103  
 Raleigh, North Carolina 27604  
 t. 919.833.5400  
 www.i-design.com

**ALIGN**  
 ENGINEERING  
 919.275.1935  
 NC License #P-2998

PROFESSIONAL SEAL  
 36841  
 7/28/23

A Tenant Alteration for  
**HARVEY JOHNS STEAKHOUSE**  
 1501 N. Raleigh Street, Suite G  
 Angier, NC

JOB #:  
 23HARVEYJOHNS

DWG BY:  
 CHK BY:  
 DATE: 07/28/23  
 REV NO DATE

ELECTRICAL  
 DETAILS

SHEET NUMBER  
**E-6**



Kitchen Equipment Connection Schedule															
Tag	Callout	Furnished By	KVA	HP	Voltage	FLA	MCA	Disconnect Size	Provided By	Nema Configuration	Fuse/Breaker Size	Feeder Size	Ground Size	Conduit Size	Note
7	Walk-In Cooler														
7.1	Lights/Door Heater	Others	0.1	-	120/1	0.88	-	M	Electrical	1	20/1	2 - #12	#12	3/4"	-
7.2	Condensor	Others	3.1	-	240/1	12.9	-	30/2	Electrical	1	20/2	3 - #12	#12	3/4"	-
14	Ice Maker	Others	1.2	-	120/1	9.6	-	Nema 5-20R	Electrical	1	20/1	2 - #12	#12	3/4"	-
23	Washer	Others	1.9	-	120/1	16	-	30/1	Electrical	1	20/1	2 - #12	#12	3/4"	-
25	Freezer	Others	0.3	-	120/1	2.62	-	Nema 5-20R	Electrical	1	20/1	2 - #12	#12	3/4"	-
26	Undercounter Refrigerator	Others	0.3	-	120/1	2.2	-	Nema 5-20R	Electrical	1	20/1	2 - #12	#12	3/4"	-
27	Refrigerator - Shorty	Others	1.0	-	120/1	8	-	Nema 5-20R	Electrical	1	20/1	2 - #12	#12	3/4"	-
29	Gas Range	Others	0.7	-	120/1	5.9	-	30/2	Electrical	1	20/1	2 - #12	#12	3/4"	-
30	Gas Convection Oven	Others	0.9	-	120/1	7.9	-	Nema 5-20R	Electrical	1	20/1	2 - #12	#12	3/4"	-
33	Refrigerator - Sandwich/Salad Prep	Others	0.7	-	120/1	6	-	Nema 5-20R	Electrical	1	20/1	2 - #12	#12	3/4"	-
34	Heat Lamp	Others	3.0	-	240/1	12.3	-	30/2	Electrical	1	20/2	3 - #12	#12	3/4"	-
35	Heated Holding Cabinet	Others	1.9	-	120/1	16	-	Nema 5-20R	Electrical	1	20/1	2 - #12	#12	3/4"	-
39	Coffee/Tea Brewer	Others	1.7	-	120/1	14	-	Nema 5-20R	Electrical	1	20/1	2 - #12	#12	3/4"	-
40	Beverage Dispenser	Others	0.1	-	120/1	1	-	Nema 5-20R	Electrical	1	20/1	2 - #12	#12	3/4"	-
41	Refrigerated Display Case	Others	0.3	-	120/1	2.7	-	Nema 5-20R	Electrical	1	20/1	2 - #12	#12	3/4"	-
42	Beer Dispenser	Others	0.3	-	120/1	2.8	-	Nema 5-20R	Electrical	1	20/1	2 - #12	#12	3/4"	-
44	Undercounter Glasswasher	Others	7.9	-	240/1	33	-	60/2	Electrical	1	45/2	3 - #8	#10	3/4"	-
46	Ice Maker	Others	0.9	-	120/1	7.2	-	Nema 5-20R	Electrical	1	20/1	2 - #12	#12	3/4"	-
47	Cold Food Station	Others	1.5	-	120/1	12.2	-	Nema 5-20R	Electrical	1	20/1	2 - #12	#12	3/4"	-

Electrical contractor shall verify all requirements, mounting height, voltage, load, connection type, etc. with equipment supplier.

Light Fixture Schedule						
Mark	Manufacturer	Fixture Description	Voltage	Driver Type	Lamp Type/Quantity	Total Wattage
XD6	Existing Fixture to be demolished	Square Recessed Light	120/1	Verify	Verify	Verify
XM7	Existing Fixture to be Relocated	2x4 Fluorescent Light	120/1	Verify	Verify	Verify
XR1	Existing Fixture to Remain	Exterior Wall mounted Light	120/1	Verify	Verify	Verify
XR4	Existing Fixture to Remain	Recessed Can light	120/1	Verify	Verify	Verify
XR4E	Same as 'XR4' with a battery	Recessed Can light	120/1	Verify	Verify	Verify
XR5	Existing Fixture to Remain	Exterior spot Light	120/1	Verify	Verify	Verify
NX7	New Location of Existing Fixture	2x4 Fluorescent Light	120/1	Verify	Verify	Verify
A	Elite #24-FPL1-LED-3000/4000/5000L-DIM10-MVOLT-30K-85	2x4 LED Light	120/1	1-LED Driver	3000 Lumen LED Light Engine	34
B	Elite #22-FPL1-LED-3000/4000/5000L-DIM10-MVOLT-30K-85	2x2 LED Light	120/1	1-LED Driver	3000 Lumen LED Light Engine	31
C	Furnished by Owner installed by GC	Track Lighting	120/1	N/A	1-8.5W LED	9
D	Furnished by Owner installed by GC	Pendant Light	120/1	N/A	1-8W LED	8
F	Furnished by Owner installed by GC	Ceiling Fan	120/1	N/A	N/A	67
G	Furnished by Owner installed by GC	Chandelier Light Fixture	120/1	N/A	8-4W LEDs	32
H	Elite #V60FCRU-2030K-F6060-*-SDM	6" Recessed Can	120/1	1-LED Driver	2000 Lumen LED Light Engine	26
H1	Elite #V60FCRU-1130K-F6060-*-SDM	6" Recessed Can	120/1	1-LED Driver	1100 Lumen LED Light Engine	15
H2	Elite #V60FCRU-1530K-F6060-*-SDM	6" Recessed Can	120/1	1-LED Driver	1500 Lumen LED Light Engine	22
J	Elite #HH4-LED-1500L-DIM10-MD-MVOLT-30K-90	4" Recessed Can	120/1	1-LED Driver	1500 Lumen LED Light Engine	18
K	Furnished by Owner installed by GC	Exterior Wall Sconce	120/1	N/A	3-4W LEDs	12
L1	Furnished by Owner installed by GC	Vanity Fixture	120/1	N/A	4-8W LEDs	32
L2	Furnished by Owner installed by GC	Vanity Fixture	120/1	N/A	3-8W LEDs	24
M	Furnished by Owner installed by GC	Bathroom Pendant	120/1	N/A	1-8W LED	8
EM	Isolite #BUG-3W-VH-SD	Emergency Wallpack (w/ Battery)	120/1			
⊗	Furnished by Owner installed by GC	Emergency Exit Light (w/ Battery)	120/1			
⊕	Furnished by Owner installed by GC	Emergency Exit Light (w/ Battery)	120/1			

**General Notes:**

- All fixtures and components shall comply with NC Building Code, 2018 North Carolina Energy Conservation Code and shall be UL listed. All led drivers shall comply with NEMA 410.
- All new, relocated, or rewired fixtures that utilize ballasts shall be provided with a luminaire disconnect where required per NEC section 410.130(G). Use Ideal PowerPlug or equal inside fixture.
- All fixtures noted as emergency shall have emergency illumination functionality as described below. Batteries must be rated for the environment in which they are installed, in all cases.
  - Interior linear led and fluorescent fixtures shall have 1,100 lumen (minimum) output, 90 minute battery. Led and fluorescent downlights shall have a 500 lumen (minimum) output, 90 minute battery. Otherwise fixture shall be provided with a full output inverter.
  - Exterior emergency fixtures shall have an integral exterior rated (0° F) or remotely mounted 1,100 lumen (minimum) output, 90 minute battery.
  - Test switches for emergency batteries/inverter shall be integral to the fixture/device served, unless otherwise noted.
  - Emergency fixtures shall operate at least one lamp where multiple emergency fixtures are to be installed in that area, and shall operate at least two lamps where the loss of a single lamp would leave the space in total darkness during emergency operation.
  - Where emergency lights provide emergency illumination in areas normally illuminated by metal halide fixtures (or similar) with restrike delay, the emergency battery shall be provided with a minimum 15 minute time delay to maintain battery illumination after the restoration of normal power.
  - Emergency lighting design is based on fixtures lumen outputs as described above. Contractor shall verify all existing emergency batteries to ensure lumen outputs are as indicated and shall replace any batteries rated less outlined above.
  - Emergency lighting units with dedicated emergency heads are spaced based on their unique output. If contractor selects an alternate fixture, they are responsible for ensuring an average of 1 foot candle is provided along the paths of egress for at least 90 minutes.
- Lamp color temperature for new lamps shall match existing to remain lamps, and all lamp colors for different fixture types and sources shall be consistent throughout the space or area unless specifically noted otherwise. Contractor shall ensure that all interior and exterior lamps are the same color temperature.
- Light fixtures indicated as dimmable shall be provide with all necessary components (driver, switch etc.) necessary to achieve 5% minimum dimming unless another specific minimum dimming level is noted.
- Light fixtures noted as "furnished by others" shall be included in the contractor's cost. The contractor shall either verify the allowance amount or specification with the architect, prior to pricing. Verify that the cost of light fixtures noted as "furnished by others" can be excluded from the contractor's price but the contractor should price installation of furnished fixtures. Verify rough-in requirements for all fixtures prior to beginning work. Unless specifically noted otherwise, the contractor is responsible for including the installation of and connection to all fixtures in their price.

Equipment Connection Schedule														
Tag	Callout	Furnished By	kVA	HP	Voltage	FLA	MCA	Disconnect Size	Provided By	Nema Configuration	Fuse/Breaker Size	Feeder Size	Ground Size	Conduit Size
AHU-1	Air Handler	Mechanical	13.9	-	240/1	-	58.0	60/2	Elec	1	60/2	3-#6	1-#10	1"
AHU-2	Air Handler	Mechanical	13.9	-	240/1	-	58.0	60/2	Elec	1	60/2	3-#6	1-#10	1"
AHU-3	Air Handler	Mechanical	13.9	-	240/1	-	58.0	60/2	Elec	1	60/2	3-#6	1-#10	1"
HP-1	Heat Pump	Mechanical	7.7	-	240/1	-	32.0	60/2	Elec	3R	50/2	3-#8	1-#10	3/4"
HP-2	Heat Pump	Mechanical	6.2	-	240/1	-	26.0	60/2	Elec	3R	40/2	3-#8	1-#10	3/4"
HP-3	Heat Pump	Mechanical	6.2	-	240/1	-	26.0	60/2	Elec	3R	40/2	3-#8	1-#10	3/4"
EF-1	Exhaust Fan	Mechanical	0.1	-	120/1	0.8	-	⌀	Elec	1	15/1	2-#12	1-#12	3/4"
EF-2	Exhaust Fan	Mechanical	0.1	-	120/1	0.8	-	⌀	Elec	1	15/1	2-#12	1-#12	3/4"
Hood														
KSF-1	Kitchen Supply Fan	Others	3.0	-	240/1	-	12.5	30/2	Elec	3R	20/2	2-#12	1-#12	3/4"
KEF-1	Kitchen Exhaust Fan	Others	2.4	-	240/1	10.0	-	30/2	Elec	3R	15/2	2-#12	1-#12	3/4"
-	Lights/Controls	Others	0.5	-	120/1	4.2	-	⌀	Elec	1	20/1	2-#12	1-#12	3/4"
FF-1	Fly Fan	Others	0.4	-	120/1	3.2	-	5-20R	Elec	1	20/1	2-#12	1-#12	3/4"
GWH	Gas Water Heater	Plumbing	0.5	-	120/1	4.0	-	⌀	Elec	1	20/1	2-#12	1-#12	3/4"
GIWH-1	Gas Instant. Water Heater	Plumbing	0.5	-	120/1	4.0	-	⌀	Elec	3R	20/1	2-#12	1-#12	3/4"
GIWH-2	Gas Instant. Water Heater	Plumbing	0.5	-	120/1	4.0	-	⌀	Elec	3R	20/1	2-#12	1-#12	3/4"
-	Booster Pump	Plumbing	2.4		208/1	11.6		30/2	Elec	1	20/2	3-#12	1-#12	3/4"

Breaker sizes for all equipment sized at MOCP where applicable.  
All disconnects for equipment shall be of fusible type and shall be fused as indicated.

**Energy Code Section C406 Compliance:**  
This project is complying with section C406 for the energy code under the provisions of C406.2 (Reduced lighting power density). The remaining provisions are therefore not required and have not been included in this design.

**Electrical System and Equipment Energy Code Compliance**  
Compliance Method: Prescriptive  
Total Interior Wattage Specified vs Allowed: **2321 vs 3434**  
See Light Fixtures Schedule for interior fixture lamp type, quantity, driver, total fixture wattage and additional information.  
Engineer Statement:  
To the best of my belief, understanding, and knowledge; the design of electrical system of this building complies with the NC State Building Code and the 2018 NC Energy Conservation Code.  
Name: Richard D. Copeland, Jr. PE

**Electrical System and Equipment Energy Code Compliance**  
Compliance Method: Prescriptive  
Total Exterior Wattage Calculation per table C405.5.1(2)  
Specified vs Allowed: 1124 vs 1200  
Base Site Allowance Zone 3 750 W  
Building Entrances and Exits:  
Main Entries 30 W/LF for 9 LF of door width  
Other Doors 20 W/LF for 9 LF of door width  
See Light Fixtures Schedule for fixture lamp type, quantity, driver, total fixture wattage and additional information.  
Engineer Statement:  
To the best of my belief, understanding, and knowledge; the design of electrical system of this building complies with the NC State Building Code and the 2018 NC Energy Conservation Code.  
Name: Richard D. Copeland, Jr. PE

