

**Project:**



Tortilleria &amp; Rosticeria Don Chon

**From:**

Cary Restaurant Equipment  
 Aziz El Qarnani  
 7050 Old Wake Forest Rd  
 Raleigh, NC 27616  
 919-655-1376  
 919-655-1376 (Contact)

Item	Qty	Description	Sell	Sell Total
<u>1</u>	1 ea	<b>WORK TABLE, STAINLESS STEEL TOP</b> Atosa USA, Inc. Model No. SSTW-3072 MixRite Work Table, 72"W x 30"D x 34"H, 18/430 stainless steel top with turned down edges, 18/430 stainless steel adjustable undershelf & legs, adjustable bullet feet, NSF, KD	\$515.00	\$515.00
			<b>ITEM TOTAL:</b>	<b>\$515.00</b>
<u>2</u>	1 ea	<b>HOT FOOD SERVING COUNTER / TABLE</b> BevLes Company Model No. BVST-4-240 Steam Table, electric, dry heat, 58"W x 22"D x 34"H, (4) open pan wells, Calrod heating elements per well, individual infinite temperate controls, LED indicator light, polyethylene cutting board, undershelf, stainless steel top and well liners, galvanized steel undershelf & legs, adjustable feet, 4000 watts, 208-230v/50-60/1-ph, cord, NEMA 6-30P, cETLus, ETL-Sanitation	\$1,300.00	\$1,300.00
	1 ea	BVSG-18-4 Sneezeguard, 18"W, for (4) well steam table	\$500.00	\$500.00
			<b>ITEM TOTAL:</b>	<b>\$1,800.00</b>
<u>3</u>	1 ea	<b>ICE MAKER WITH BIN, CUBE-STYLE</b> Atosa USA, Inc. Model No. YR280-AP-161 Ice Maker with Bin, cube-style, air-cooled, self-contained condenser, 23.7"W x 28.5"D x 38.6"H, production capacity up to 283-lb/24 hours, 88 lb storage capacity, stainless steel exterior, 6" adjustable legs, includes: ice scoop, removable air filter, R290 Hydrocarbon refrigerant, 115v/60/1-ph, 7.2 amps, cETLus, ETL-Sanitation, NSF, ENERGY STAR® (drain required)	\$2,520.00	\$2,520.00
	1 ea	2 year labor & parts warranty, 5 years warranty on compressor (continental USA only)		

Initial: \_\_\_\_\_

Item	Qty	Description	Sell	Sell Total
			<b>ITEM TOTAL:</b>	<b>\$1,940.00</b>
<u>8</u>	1 ea	<b>THREE (3) COMPARTMENT SINK</b> Atosa USA, Inc. Model No. MRSA-3-D MixRite Sink, 3-compartment, 90"W x 24"D x 44-1/2"H overall, (3) 18"W x 18" front-to-back x 12" deep sink compartments, 18" left & right drainboards, 18 gauge stainless steel, galvanized legs, adjustable ABS feet, NSF (must be purchased in quantities of (6 each), unless doing will call pick up)	\$970.00	\$970.00
			<b>ITEM TOTAL:</b>	<b>\$970.00</b>
<u>9</u>	1 ea	<b>DUNNAGE RACK</b> Serv-Ware Model No. CWP-DR-246012 Dunnage Rack, 60"W x 24"D x 12"H, 2000 lbs weight capacity, 1-1/2" square all welded aluminum construction, NSF	\$84.59	\$84.59
			<b>ITEM TOTAL:</b>	<b>\$84.59</b>
<u>10</u>	1 ea	<b>REFRIGERATED MERCHANDISER</b> True Mfg. - General Foodservice Model No. GDM-49-HC~TSL01 Refrigerated Merchandiser, two-section, True standard look version 01, (8) shelves, (2) double pane thermal insulated glass hinged doors, LED interior lights, powder coated steel exterior, white interior with stainless steel floor, R290 Hydrocarbon refrigerant, 1/2 HP, 115v/60/1-ph, 8.5 amps, NEMA 5-15P, cULus, UL EPH Classified, Made in USA, ENERGY STAR® 1 ea NOTE: Commonly stocked model in black exterior, & white exterior; verify availability with factory 1 ea Self-contained refrigeration standard 1 ea Warranty - 5 year parts & labor, please visit <a href="http://www.Truemfg.com">www.Truemfg.com</a> for specifics 1 ea Warranty - 7 year compressor (self-contained only), please visit <a href="http://www.Truemfg.com">www.Truemfg.com</a> for specifics 1 ea Left door hinged left, right door hinged right standard 1 ea Exterior: Black powder coated steel, standard 1 ea Interior: White aluminum, with white shelving, standard 1 ea Illuminated sign decal: S-TS-02 "TRUE Stripe" graphic, standard	\$5,700.00	\$5,700.00
			<b>ITEM TOTAL:</b>	<b>\$5,700.00</b>
			Merchandise	\$21,269.59
			Subtotal	\$21,269.59
			Total	\$21,269.59

Prices Good Until: 10/20/2022

Acceptance: \_\_\_\_\_ Date: \_\_\_\_\_

Printed Name: \_\_\_\_\_

Project Grand Total: \$21,269.59





**"MAKE THIS STEEL RITE!"**

Toll Free: 855-855-0399 Email: info@atosausa.com

www.atosa.com | www.atosausa.com

California, Colorado, Florida, Georgia, Illinois, Massachusetts, New Jersey, Ohio, Texas, Washington

# Work Tables (30 Inch Series)

## Standard Features

- 18 gauge, 430 stainless steel table including the undershelf and legs
- Entire top mechanically polished to a satin finish
- Top is sound deadened
- All edges are turned down as a safety feature
- Stainless steel tubular legs and undershelf are standard features on all models
- Under shelf can be adjusted to desired height
- Adjustable bullet feet
- Ships K.D
- Easy to assemble

## MODELS:

SSTW-3030 / SSTW-3036 / SSTW-3048  
SSTW-3060 / SSTW-3072 / SSTW-3084 / SSTW-3096



Models	Undershelf Dimensions	Top Shelf Capacity	Under Shelf Capacity
SSTW-3030	24" x 24"	440 lbs.	330 lbs.
SSTW-3036	30" x 24"	470 lbs.	350 lbs.
SSTW-3048	42" x 24"	500 lbs.	370 lbs.
SSTW-3060	54" x 24"	520 lbs.	390 lbs.
SSTW-3072	66" x 24"	540 lbs.	410 lbs.
SSTW-3084	78" x 24"	660 lbs.	460 lbs.
SSTW-3096	90" x 24"	680 lbs.	480 lbs.



90 DAYS WARRANTY ON WORKMANSHIP





Atosa USA, Inc.

SSTW-3072 ()

Item#: 1



**"WE MAKE THE KITCHEN BETTER!"**

Toll Free: 855-855-0399 Email: [info@atosausa.com](mailto:info@atosausa.com)

[www.atosa.com](http://www.atosa.com) | [www.atosausa.com](http://www.atosausa.com)

California, Colorado, Florida, Georgia, Illinois,  
Massachusetts, New Jersey, Ohio, Texas, Washington



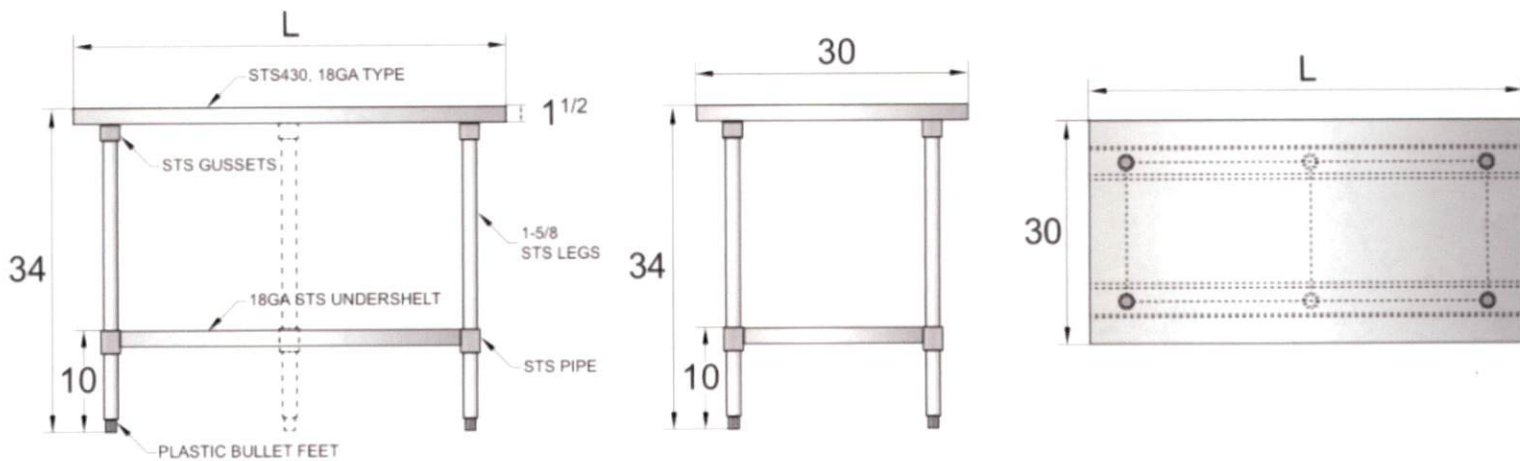

### SPECIFICATIONS

Models	Legs	Ga.	Exterior Dimensions(inch)	Packaging Dimensions(inch)	Net Weight(lbs)	Gross Weight(lbs)
SSTW-3030	4	18	30(L)×30×34	35×32×4	41	45
SSTW-3036	4	18	36(L)×30×34	37×32×4	45	51
SSTW-3048	4	18	48(L)×30×34	50×32×4	57	62
SSTW-3060	4	18	60(L)×30×34	62×32×4	67	73
SSTW-3072	4	18	72(L)×30×34	74×32×4	77	86
SSTW-3084	6	18	84(L)×30×34	86×32×4	93	103
SSTW-3096	6	18	96(L)×30×34	98×32×4	103	115

### PLAN VIEW



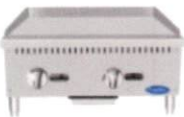

Item	Qty	Description	Sell	Sell Total
	1 ea	3M™ ICE120-S Water Filter System included		
			<b>ITEM TOTAL:</b>	<b>\$2,520.00</b>
<b>4</b>	1 ea	<b>REACH-IN FREEZER</b>	\$3,700.00	\$3,700.00
		Hoshizaki Model No. EF2A-FS Economy Series Freezer, reach-in, two-section, 38.54 cu. ft., bottom mounted self-contained refrigeration, (6) adjustable epoxy coated shelves, (2) full-height solid hinged doors with locks, digital temperature display/controls, temperature alarms, LED interior lighting, stainless steel interior floor, aluminum interior sides, rear, & top, stainless steel front, gray painted steel exterior sides, top & rear, (6) 4" casters (2 with brakes), R290 Hydrocarbon refrigerant, 1/2 HP, NEMA 5-15P, UL EPH Classified, cULus		
	1 ea	Warranty: 2-Year parts & labor on entire machine		
	1 ea	Warranty: 5-Year parts on compressor		
	1 ea	115v/60/1-ph, 4.7 amps, standard		
			<b>ITEM TOTAL:</b>	<b>\$3,700.00</b>
<b>5</b>	1 ea	<b>REACH-IN REFRIGERATOR</b>	\$3,170.00	\$3,170.00
		Hoshizaki Model No. ER2A-FS Economy Series Refrigerator, reach-in, two-section, 38.61 cu. ft., bottom mounted self-contained refrigeration, (6) adjustable epoxy coated shelves, (2) full-height solid hinged doors with locks, digital temperature display/controls, temperature alarms, LED interior lighting, stainless steel interior floor, aluminum interior sides, rear, & top, stainless steel front, gray painted steel exterior sides, top & rear, (6) 4" casters (2 with brakes), R290 Hydrocarbon refrigerant, 1/3 HP, NEMA 5-15P, UL EPH Classified, cULus, ENERGY STAR®		
	1 ea	Warranty: 2-Year parts & labor on entire machine		
	1 ea	Warranty: 5-Year parts on compressor		
	1 ea	115v/60/1-ph, 4.3 amps, standard		
			<b>ITEM TOTAL:</b>	<b>\$3,170.00</b>
<b>6</b>	1 ea	<b>GRIDDLE, GAS, COUNTERTOP</b>	\$870.00	\$870.00
		Atosa USA, Inc. Model No. ATMG-24 CookRite Heavy Duty Griddle, gas, countertop, 24"W x 28-3/5"D x 15-1/5"H, (23-9/10"W x 19-9/10"D cooking area), 3/4" thick griddle plate, (2) stainless steel burners, standby pilots, independent manual controls, stainless steel structure, adjustable stainless steel legs, 60,000 total BTU's, cETLus, ETL-Sanitation		
	1 ea	1 year parts & labor warranty (continental USA only)		
	1 ea	Gas type to be specified		
			<b>ITEM TOTAL:</b>	<b>\$870.00</b>
<b>7</b>	1 ea	<b>RANGE, 36" 6 OPEN BURNERS</b>	\$1,940.00	\$1,940.00
		Atosa USA, Inc. Model No. AGR-6B-NG CookRite Range, natural gas, 36"W x 31"D x 57-3/8"H, (6) 32,000 BTU open burners, removable cast iron top grates, (1) 26-1/2"W oven, (2) adjustable chrome oven racks, pilot light, drip tray, stainless steel front, back sides, kick plate, back guard & over shelf, (4) casters, 219,000 total BTU's, cETLus, ETL-Sanitation		
	1 ea	1 year parts & labor warranty (continental USA only)		



# ER1A-FS/ER2A-FS

One and Two Section Full Stainless Refrigerator

## W x D x H

27" x 29.63" x 81.63"  
(including 4" casters)



## W x D x H

54.38" x 29.63" x 81.63"  
(including 4" casters)



Item #: \_\_\_\_\_

Project: \_\_\_\_\_

Qty: \_\_\_\_\_

AIA#: \_\_\_\_\_

## Features

- Energy efficient interior LED light
- Environmentally friendly R290 hydrocarbon refrigerant
- Solid state digital controller with temperature alarm and LED display (Fahrenheit or Celsius)
- Self-closing door(s) is field reversible
- Stainless steel exterior door(s) come standard with lock(s)
- Stainless steel interior floor with aluminum sides, and top
- Time initiated automatic defrost
- Energy efficient heated condensate removal
- Heavy duty grey epoxy coated shelves are adjustable in 1/2" increments; 3 per section. 105 lbs. capacity
- Aluminum shelf supports
- Standard with 4" casters (two with brakes)
- 9 ft. cord and plug
- Container Qty:

ER1A-FS: 47

ER2A-FS: 28



## Dimensions / Capacity

Interior Storage Capacity (CF) (AHAM)

Overall Width x Depth

Height (including 4" casters)

Door Opening (W x H)

Depth with Door Open at 90°

Adjustable Shelves

Shelf Dimensions (W x D)

Crated Shipping Weight

Crated Length x Depth x Height

## One Section ER1A-FS

17.8 ft<sup>3</sup>

27" x 29.63"

81.63"

22.25" x 52.1"

55.38"

3

21.5" x 23.1"

279 lbs

31.5" x 28.75" x 84"

## Two Section ER2A-FS

38.61 ft<sup>3</sup>

54.38" x 29.63"

81.63"

22.9" x 52.1"

55.38"

6

24.3" x 21.7"

523 lbs

58" x 31.5" x 84"

## Electrical / Refrigeration

Voltage

HACR Breaker

Electrical Connection (NEMA)

Voltage Range

Ambient Temp. Range

Control Setpoint Range

Amperage

Energy Consumption (kWh/day) @ASHRAE

Approx. Nominal Compress. BTU/HR (HP)

Refrigerant / Charge Amount (oz.)

## One Section ER1A-FS

115/60/1

15.0 Amps

5-15P Ⓢ

103-127

45° to 100°F

33° to 39°F

2

1.06

1960(1/5HP)

R290 / (2.3oz)

## Two Section ER2A-FS

115/60/1

15.0 Amps

5-15P Ⓢ

103-127

45° to 100°F

33° to 39°F

4.3

2.1

4291(1/3HP)

R290 / (3.7oz)

## Options

Additional epoxy shelves

HS-5511(1 section)

## Warranty

\* 2 Year - Parts and Labor on entire machine.

5 Year - Parts on Compressor



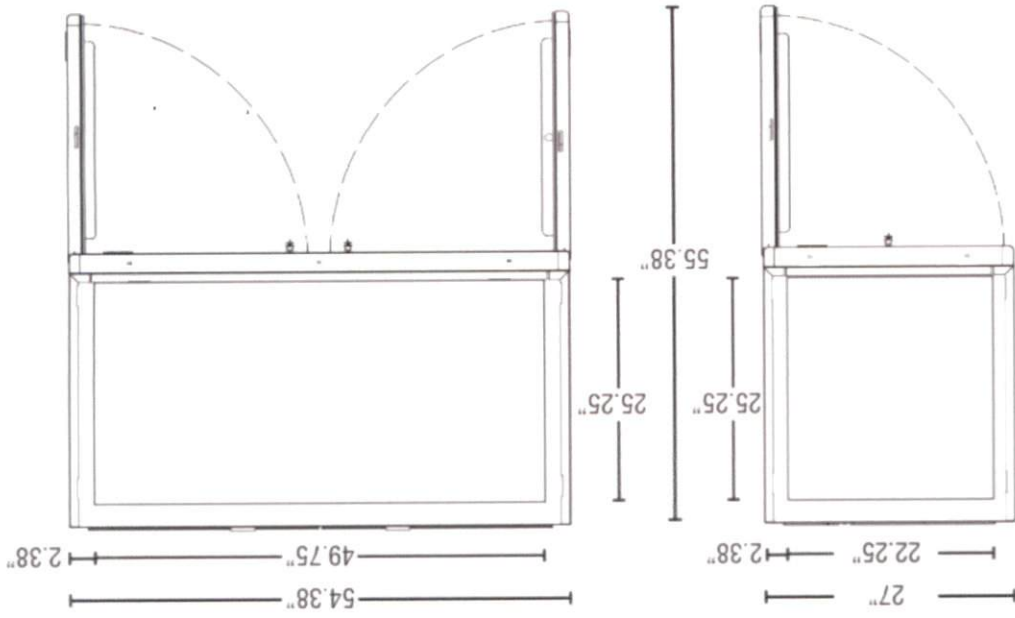

PLAN VIEW

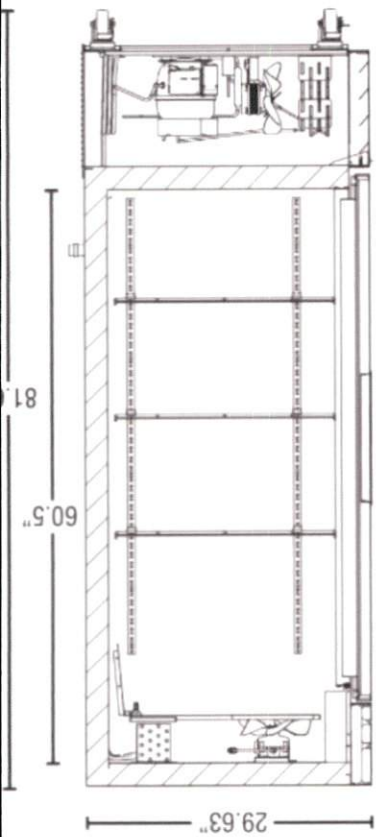

SIDE VIEW

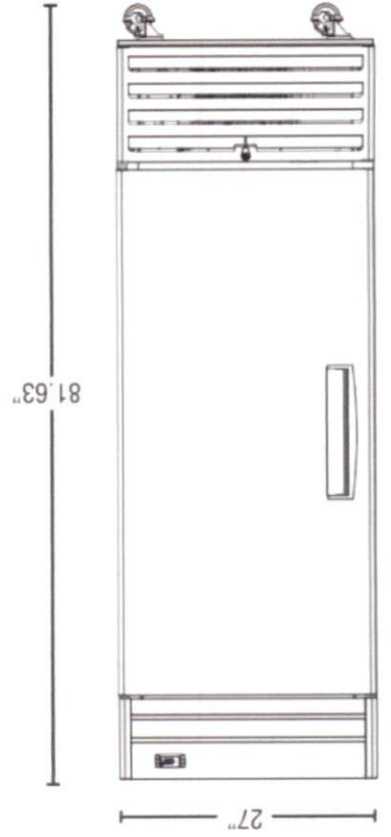
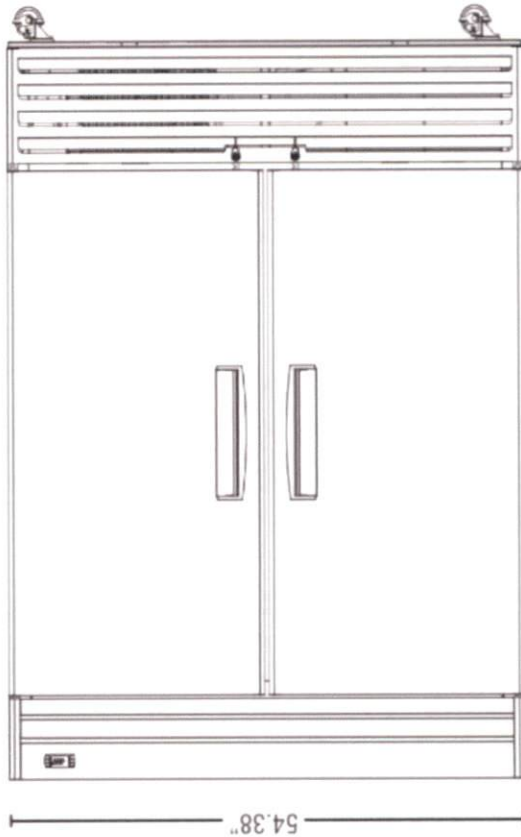

FRONT VIEW

# EF1A-FS/EF2A-FS

One and Two Section Full Stainless Freezer



Hoshizaki

EF2A-FS ( )

Item#: 4

EF1A-FS/EF2A-FS  
10/3  
Item # 1

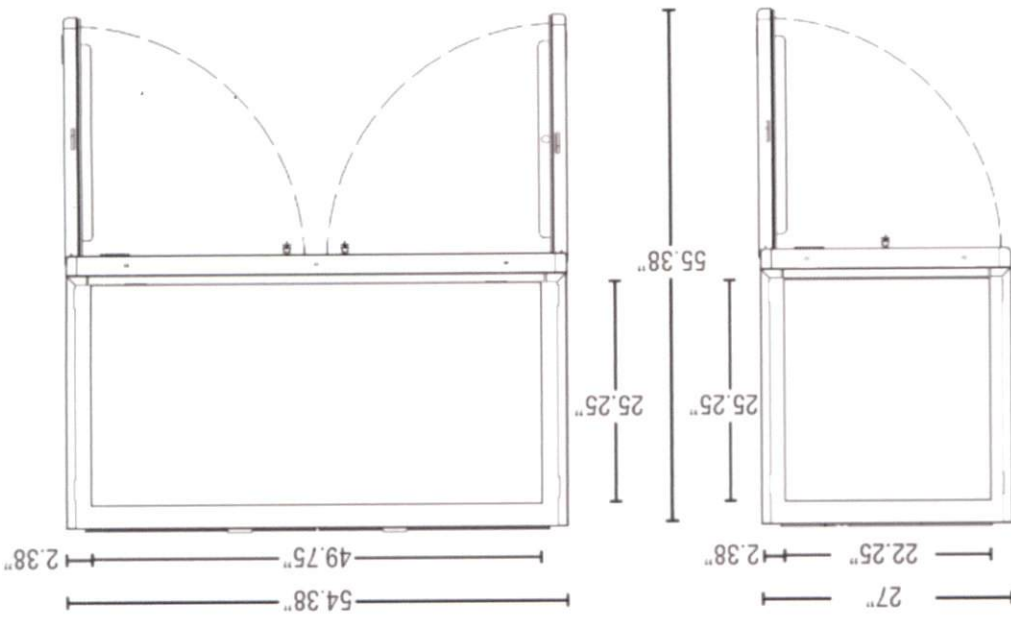

PLAN VIEW

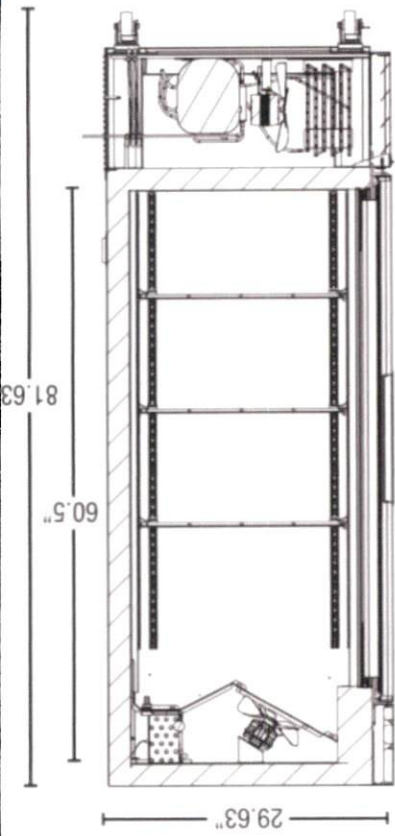

SIDE VIEW

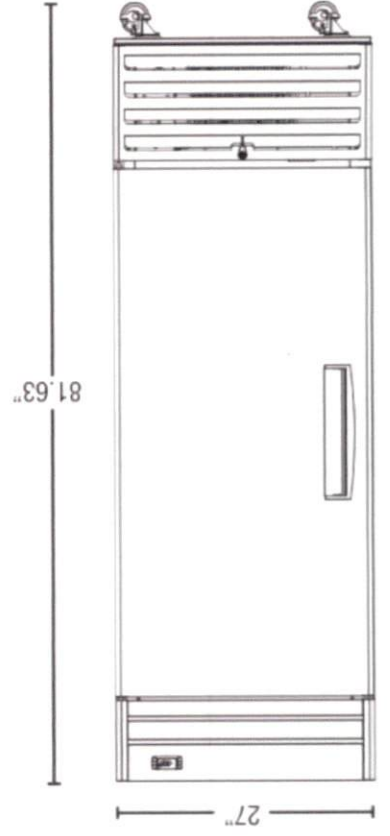

FRONT VIEW

# ER1A-FS/ER2A-FS

One and Two Section Full Stainless Refrigerator



Hoshizaki

ER2A-FS ( )

Item#: 5

ER1A-FS/ER2A-FS  
10/30  
Item # 13



**SPECIFICATIONS**

Models	Burners and control method	Gas type	Intake-tube pressure (in.W.C.)	Per BTU B.T.U./h	Total BTU B.T.U./h	Regulator	Work area (inch)	Net weight (lbs)	Gross weight (lbs)
ATMG-24	2 Burners Independent Manual Control	NG	4	30,000	60,000	4" w.c.	23 <sup>9/10</sup> × 19 <sup>9/10</sup>	160.9	194.5
		LP	10	30,000	60,000	10" w.c.			
ATMG-36	3 Burners Independent Manual Control	NG	4	30,000	90,000	4" w.c.	35 <sup>7/10</sup> × 19 <sup>9/10</sup>	229	280.9
		LP	10	30,000	90,000	10" w.c.			
ATMG-48	4 Burners Independent Manual Control	NG	4	30,000	120,000	4" w.c.	47 <sup>9/10</sup> × 19 <sup>9/10</sup>	294	414
		LP	10	30,000	120,000	10" w.c.			

**PLAN VIEW**

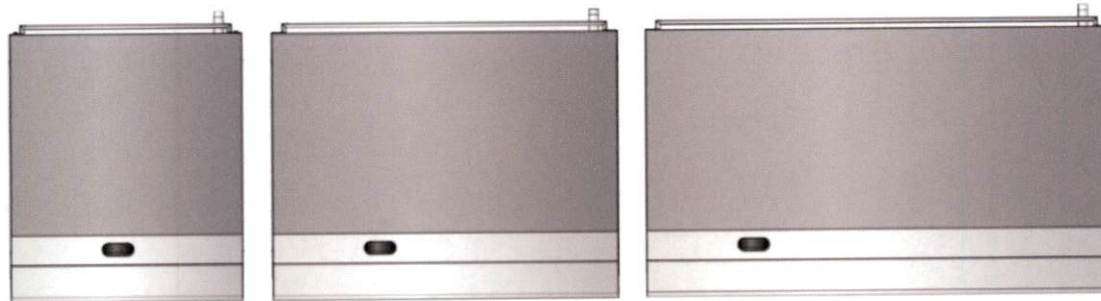
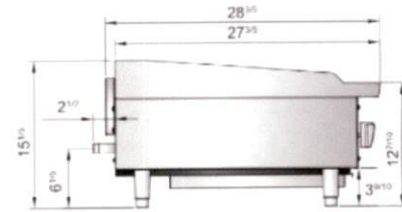
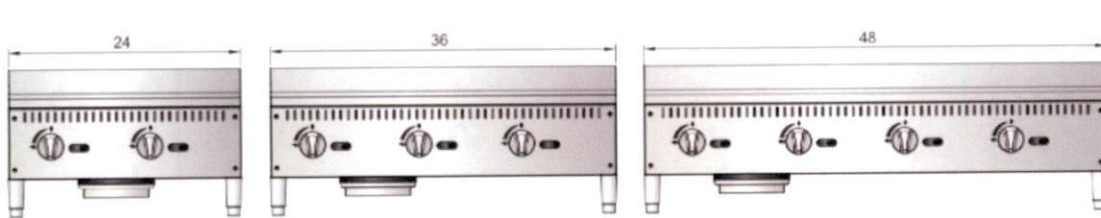

**ATMG-24**

**ATMG-36**

**ATMG-48**

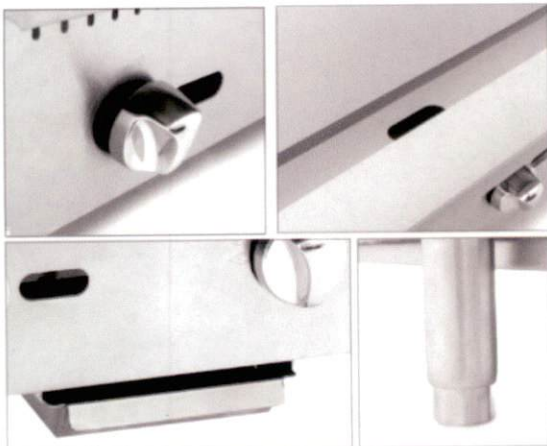



Toll Free: 855-855-0399 Email: info@atosausa.com  
 www.atosa.com | www.atosausa.com  
 California, Colorado, Florida, Georgia, Illinois,  
 Massachusetts, New Jersey, Ohio, Texas, Washington

# Three Comp. Sink & Three Comp. Bakery Sheet Pan Sink

**MODELS:**  
 MRSA-3-D / MRSB-3-D

## Standard Features

- Entire sink is formed from a single sheet, fused and polished creating a one-piece sanitary unit
- MRSA model has 18" drainboards
- MRSB model has 24" drainboards
- All exposed welds are ground smooth and polished to blend with adjacent surfaces providing a satin finish
- Large radius on all corners both vertically and horizontally
- Creased and angled drain boards for easy drainage
- Galvanized legs are standard on all models
- Adjustable ABS bullet feet
- Faucets sold separately



MRSA-3-D



MRSB-3-D

## Optional Features

- Leg cross bar (pair) part #: MRPN007

Models	Ga.	Bowl Size (inch) (L×D×H*)	Leg Size (inch)	Exterior Dimensions (inch) (L×D×H)	Net Weight (lbs)
MRSB-3-D	16	24 × 24 × 14	19 <sup>1/2</sup>	120 × 30 × 44 <sup>1/2</sup>	161
MRSA-3-D	18	18 × 18 × 12	21 <sup>1/2</sup>	90 × 24 × 44 <sup>1/2</sup>	84

## PLAN VIEW

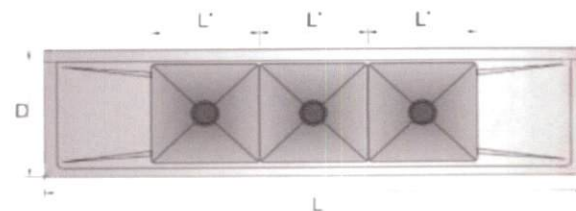
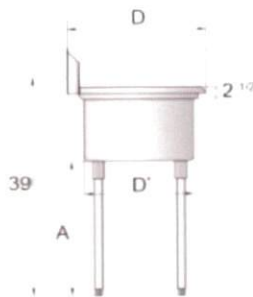
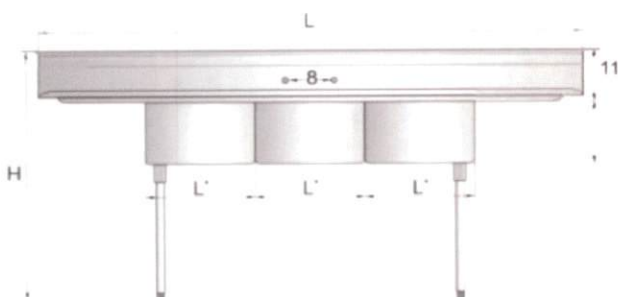





**"TO COOK NICELY!"**

Toll Free: 855-855-0399 Email: info@atosausa.com  
 www.atosa.com | www.atosausa.com  
 California, Colorado, Florida, Georgia, Illinois,  
 Massachusetts, New Jersey, Ohio, Texas, Washington

**SPECIFICATIONS**

Models	Gas Type	Burner Name	Total BTU B.T.U./h	Number of Burners	Valve Types	Oven Size (inch)	Hot Plates Working Area (inch)	Exterior Dimensions (inch)	Net Weight (lbs)	Gross Weight (lbs)
AGR-4B	NG	Hot plates	128,000	4	Pilot light	20×26×14	4pcs 11 <sup>4/2</sup> ×11 <sup>4/2</sup>	24×31×57 <sup>3/8</sup>	326	428
		Oven	24,000	1						
	LP	Hot plates	128,000	4						
		Oven	24,000	1						
AGR-6B	NG	Hot plates	192,000	6	Pilot light	26 <sup>1/2</sup> ×26×14	6pcs 11 <sup>4/2</sup> ×11 <sup>4/2</sup>	36×31×57 <sup>3/8</sup>	440	568
		Oven	27,000	1						
	LP	Hot plates	192,000	6						
		Oven	27,000	1						
AGR-8B	NG	Hot plates	256,000	8	Pilot light	20×26×14	8pcs 11 <sup>4/2</sup> ×11 <sup>4/2</sup>	48×31×57 <sup>3/8</sup>	607	765
		Oven	48,000	2						
	LP	Hot plates	256,000	8						
		Oven	48,000	2						
AGR-10B	NG	Hot plates	320,000	10	Pilot light	26 <sup>1/2</sup> ×26×14	10pcs 11 <sup>4/2</sup> ×11 <sup>4/2</sup>	60×31×57 <sup>3/8</sup>	732	897
		Oven	54,000	2						
	LP	Hot plates	320,000	10						
		Oven	54,000	2						

**PLAN VIEW**



Heavy duty burners    Chrome oven rack    Stainless steel knobs

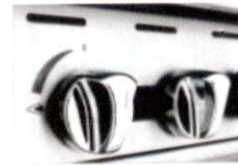
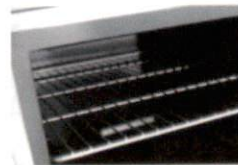





**"TO COOK NICELY!"**

Toll Free: 855-855-0399 Email: [info@atosausa.com](mailto:info@atosausa.com)  
[www.atosa.com](http://www.atosa.com) | [www.atosausa.com](http://www.atosausa.com)  
 California, Colorado, Florida, Georgia, Illinois,  
 Massachusetts, New Jersey, Ohio, Texas, Washington

# Gas Ranges

## (4, 6, 8 & 10 Burner models)

### MODELS:

AGR-4B / AGR-6B / AGR-8B / AGR-10B

### Standard Features

- Stainless steel exterior including front, back sides, kick plate, back guard and over shelf
- Heavy duty 12" X 12" removable, cast iron top grates
- Drip tray provided under burners to catch grease drippings
- 32,000 BTU top burners & 27,000 BTU oven burners
- Oven temperature range between 175°F to 550°F
- Standing pilot for open top burners
- Oven pilot with 100% safety shut off
- Enamel interior oven for easy cleaning
- Multiple position oven rack guides
- Two(2) chrome oven rack per oven standard
- Available in Natural and Propane
- 3/4" NPT rear gas connection and regulator provided
- Four(4) casters standard

### Optional Accessories

- Leg part #: 301110006
- AGR-4B/AGR-8B extra oven rack part #: 301100013
- AGR-6B/AGR-10B extra oven rack part #: 301100012



AGR-4B



AGR-10B



AGR-6B



AGR-8B



1 YR WARRANTY ON ALL PARTS AND LABOR (US ONLY)



Complies to ANSI  
 Z127.2-110-2005 (2011)  
 Complies to CSA  
 Z127.1-110-2005 (2011)  
 Complies to NSF  
 3-A-2011 (2011)





# EF1A-FS/EF2A-FS

One and Two Section Full Stainless Freezer

## W x D x H

27" x 29.63" x 81.63"  
(including 4" casters)

## W x D x H

54.38" x 29.63" x 81.63"  
(including 4" casters)

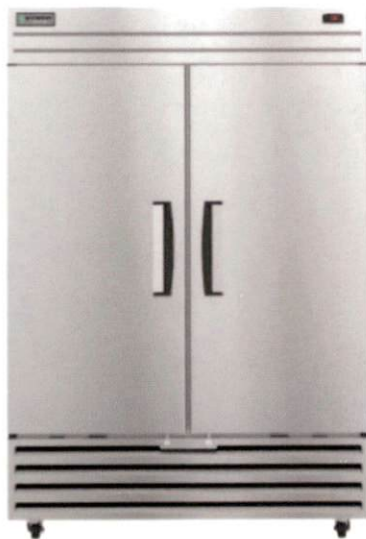

## Dimensions / Capacity

Interior Storage Capacity (CF) (AHAM)

Overall Width x Depth

Height (including 4" casters)

Door Opening (W x H)

Depth with Door Open at 90°

Adjustable Shelves

Shelf Dimensions (W x D)

Crated Shipping Weight

Crated Length x Depth x Height

## One Section EF1A-FS

17.74 ft<sup>3</sup>

27" x 29.63"

81.63"

22.25" x 52.1"

55.38"

3

21.5" x 23.1"

279 lbs

31.5" x 28.75" x 84"

## Two Section EF2A-FS

38.54 ft<sup>3</sup>

54.38" x 29.63"

81.63"

22.9" x 52.1"

55.38"

6

24.3" x 21.7"

523 lbs

58" x 31.5" x 84"

## One Section EF1A-FS

115/60/1

15.0 Amps

5-15P (1)

103-127

45° to 100°F

-5° to 5°F

3.2

4.62

1399(1/3HP)

R290 / (3.5oz)

## Two Section EF2A-FS

115/60/1

15.0 Amps

5-15P (1)

103-127

45° to 100°F

-5° to 5°F

4.7

8.8

2074(1/2HP)

R290 / (4.2oz)

## Options

Additional epoxy shelves

HS-5511(1 section)

## Warranty

\* 2 Year - Parts and Labor on entire machine.

5 Year - Parts on Compressor

Item #: \_\_\_\_\_

Project: \_\_\_\_\_

Qty: \_\_\_\_\_

AIA#: \_\_\_\_\_

## Features

- Energy efficient interior LED light
- Environmentally friendly R290 hydrocarbon refrigerant
- Solid state digital controller with temperature alarm and LED display (Fahrenheit or Celsius)
- Self-closing door(s) is field reversible
- Stainless steel exterior door(s) come standard with lock(s)
- Stainless steel interior floor with aluminum sides, and top
- Time initiated automatic defrost
- Energy efficient heated condensate removal
- Heavy duty grey epoxy coated shelves are adjustable in 1/2" increments; 3 per section. 105 lbs. capacity
- Aluminum shelf supports
- Standard with 4" casters (two with brakes)
- 9 ft. cord and plug
- Container Qty:  
ER1A-FS: 47  
ER2A-FS: 28





**"WE MAKE THE KITCHEN BETTER!"**

Toll Free: 855-855-0399 Email: [info@atosausa.com](mailto:info@atosausa.com)

[www.atosa.com](http://www.atosa.com) | [www.atosausa.com](http://www.atosausa.com)

California, Colorado, Florida, Georgia, Illinois,  
Massachusetts, New Jersey, Ohio, Texas, Washington

## MODELS:

YR280-AP-161

# 280 lb. Ice Machine

## Standard Features

- Up to 283 lb. production ice machine (per 24 hrs)
- Built-in storage capacity of 88 lbs. (under counters)
- Durable stainless steel exterior
- Slanted black plastic bin door
- Ice scoop included
- Height includes leg levelers
- Air cooled condenser
- Removable air filter
- Power switch accessible without panel removal
- For freestanding or built-in applications
- Requires use of a drain
- ETL Listed and ETL Sanitation Listed
- Ice machine includes a 3M water filter system Model #ICE120-S



All Atosa Ice machines should have the included 3M water filter system & cartridge installed. Recommended 3M cartridge replacement is recommended every 6 months. *(may vary based on water quality)*

**Maintenance and cleaning are not covered under warranty**

Half-diced cube



Inlet hose



Drain hose



Ice scoop



Dimension(inch)

3/8×7/8×7/8

1. Don't forget to leave the unit some room to breathe!
2. Please clean the condenser frequently to give the unit more fresh air.



2 YEAR PARTS AND LABOR WARRANTY (US ONLY)







**"WE MAKE THE KITCHEN BETTER"**

Toll Free: 855-855-0399 Email: info@atosausa.com

www.atosa.com | www.atosausa.com

California, Colorado, Florida, Georgia, Illinois, Massachusetts, New Jersey, Ohio, Texas, Washington

**SPECIFICATIONS**

Model	Type	Refrigerant	Voltage (V/Hz/Ph)	Amps(A)	Watts(W)	kWh/100 lbs Ice	Ice-Making Capacity (lbs/hr)	Leg (inch)	Exterior Dimensions (inch)	Gr Wei (lb)
YR280-AP-161	Cube ice	R290	115/60/1	7.2	704	5.97	283/24	6	23 <sup>1/2</sup> ×28 <sup>1/2</sup> ×38 <sup>3/5</sup>	18

**PLAN VIEW**

YR280-AP-161 Front View

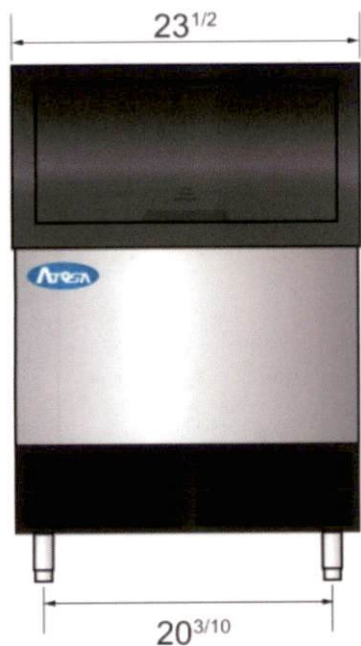

YR280-AP-161 Top View

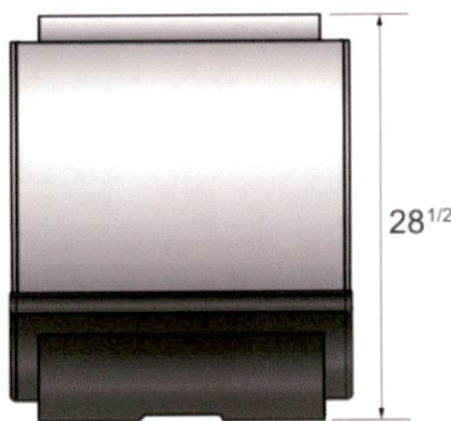

YR280-AP-161 Side View



**Ice machine comparison**

Models	Type	Refrigerant	Voltage (V/Hz/Ph)	Amps(A)	Watts(W)	kWh/100 lbs Ice	Ice-Making Capacity (lbs/hr)	Leg (inch)	Exterior Dimensions (inch)	Gr Wei (lb)
YR140-AP-161	Cube ice	R290	115/60/1	3.1	363	6.13	142/24	6	23 <sup>1/2</sup> ×28 <sup>1/2</sup> ×38 <sup>3/5</sup>	11
YR450-AP-161	Cube ice	R290	115/60/1	9.6	965	5.04	460/24	6	30 <sup>1/5</sup> ×24 <sup>9/20</sup> ×21 <sup>7/10</sup>	15
YR800-AP-261	Cube ice	R-404a	220/60/1	7.5	1750	5.18	810/24	6	30 <sup>1/5</sup> ×24 <sup>9/20</sup> ×31 <sup>7/10</sup>	23

True Mfg. - General Foodservice

GDM-49-HC~TSL01 ( )

Item#: 10



**TRUE MANUFACTURING CO., INC.**  
U.S.A. FOODSERVICE DIVISION

2001 East Terra Lane • O'Fallon, Missouri 63366-4434 • (636)240-2400  
Fax (636)272-2408 • Toll Free (800)325-6152 • Intl Fax# (001)636-272-7546  
Parts Dept. (800)424-TRUE • Parts Dept. Fax# (636)272-9471 • www.truemfg.com

Project Name: \_\_\_\_\_

Location: \_\_\_\_\_

Item #: \_\_\_\_\_ Qty: \_\_\_\_\_

Model #: \_\_\_\_\_

A/A #

S/S #

Model:

**GDM-49-HC~TSL01**

**Glass Door Merchandiser:**

*Swing Door Refrigerator with Hydrocarbon Refrigerant~True Standard Look Version 01*



**GDM-49-HC~TSL01**

- ▶ The world's #1 manufacturer of glass door merchandisers.
- ▶ Factory engineered, self-contained, capillary tube system using environmentally friendly R290 hydrocarbon refrigerant that has zero (0) ozone depletion potential (ODP), & three (3) global warming potential (GWP).
- ▶ High capacity, factory balanced, refrigeration system holds 33°F to 38°F (.5°C to 3.3°C) for best food preservation in extreme conditions.
- ▶ Exterior - non-peel or chip black powder coated cold rolled steel; durable and permanent.
- ▶ Interior - attractive, NSF approved, white aluminum interior liner with stainless steel floor.
- ▶ Double pane thermal insulated glass swing doors. Black powder coated.
- ▶ Self closing doors. Positive seal, torsion type closure system.
- ▶ LED interior lighting provides more even lighting throughout the cabinet. Safety shielded.
- ▶ Entire cabinet structure is foamed-in-place using a high density, polyurethane insulation that has zero ozone depletion potential (ODP) and zero global warming potential (GWP).

**Bottom mounted units feature:**

- ▶ "No stoop" lower shelf to maximize product visibility.
- ▶ Storage on top of cabinet.
- ▶ Easily accessible condenser coil for cleaning.

Exterior Color Options



Standard Black Exterior



Optional White Exterior



Optional Stainless Exterior

**ROUGH-IN DATA**

Specifications subject to change without notice.  
Chart dimensions rounded up to the nearest 1/8" (millimeters rounded up to next whole number).

Model	Doors	Shelves	Cabinet Dimensions (inches) (mm)			HP	Voltage	Amps	NEMA Config.	Cord Length (total ft.) (total m)	Crated Weight (lbs.) (kg)
			W	D†	H						
GDM-49-HC~TSL01	2	8	54 1/8 1375	29 7/8 759	78 3/8 1998	1/2 N/A	115/60/1	7.3 N/A	5-15P	9 2.74	465 211

† Depth does not include 1 1/8" (42 mm) for door handles.



APPROVALS:

AVAILABLE AT:





## ELECTRIC STEAM TABLES

FRONT VIEW

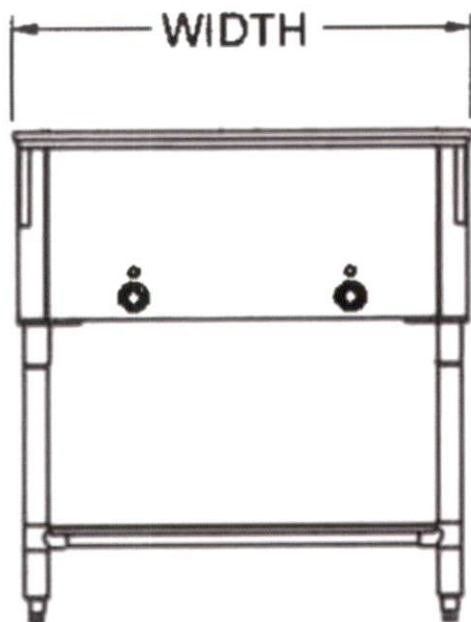

SIDE VIEW

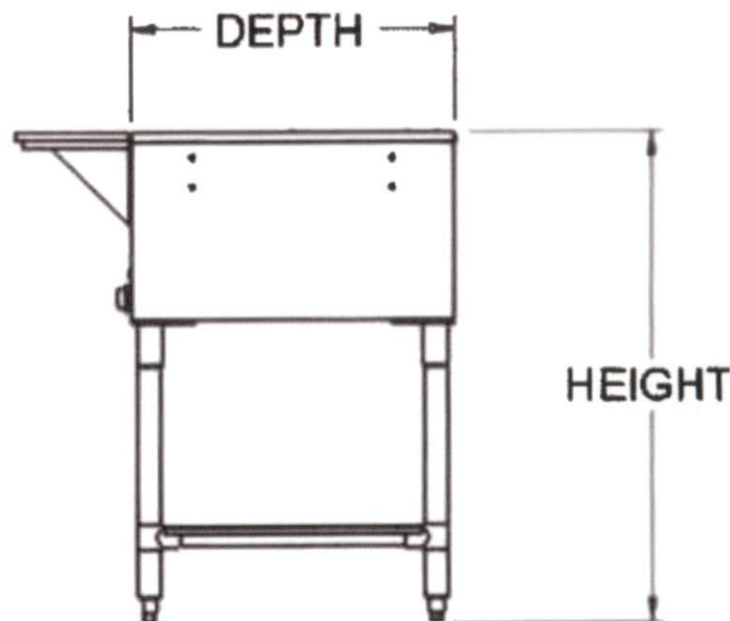

MODEL	VOLTAGE	WATTS	PLUG	WIDTH	DEPTH	HEIGHT	SHIPPING WEIGHT
BVST2-120	120V / 60Hz / 1 Ph	1000N	NEMA 5-15P	30" 762 mm	22" 572 mm	34" 864 mm	95 lbs 43 kg
BVST3-120	120V / 60Hz / 1 Ph	1500N	NEMA 5-15P	44" 1118 mm	22" 572 mm	34" 864 mm	R-290A 3.0 oz (85 g)
BVST4-120	120V / 60 Hz / 1 Ph	2000N	NEMA 5-30P	58" 1473 mm	22" 572 mm	34" 864 mm	160 lbs 73 kg
BVST2-240	208-230V / 50-60Hz / 1 Ph	1500 / 2000N	NEMA 6-20P	30" 762 mm	22" 572 mm	34" 864 mm	95 lbs 43 kg
BVST3-240	208-230V / 50-60Hz / 1 Ph	2250 / 3000N	NEMA 6-20P	44" 1118 mm	22" 572 mm	34" 864 mm	128 lbs 58 kg
BVST4-240	208-230V / 50-60Hz / 1 Ph	3000 / 4000N	NEMA 6-30P	58" 1473 mm	22" 572 mm	34" 864 mm	160 lbs 73 kg
BVST5-240	208-230V / 50-60Hz / 1 Ph	3750 / 5000N	NEMA 6-30P	72" 1828 mm	22" 572 mm	34" 864 mm	197 lbs 89 kg



Item# \_\_\_\_\_

Project: \_\_\_\_\_

Qty: \_\_\_\_\_

# Aluminum Dunnage Rack

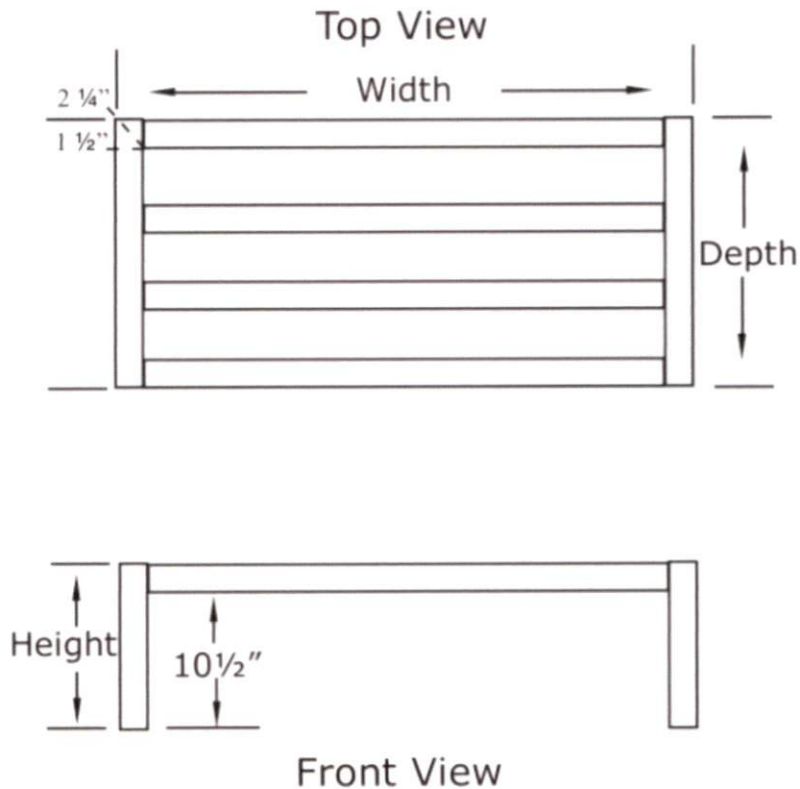

<b>Model</b>	<b>Size</b> (D x W x H)	<b>Capacity</b>	<b>Weight/lbs</b> (Shipping)
CWP-DR-203612	20" x 36" x 12"	2500 lbs	9
CWP-DR-204812	20" x 48" x 12"	2200 lbs	11
CWP-DR-206012	20" x 60" x 12"	2000 lbs	13
CWP-DR-243612	24" x 36" x 12"	2500 lbs	10
CWP-DR-244812	24" x 48" x 12"	2200 lbs	13
CWP-DR-246012	24" x 60" x 12"	2000 lbs	15

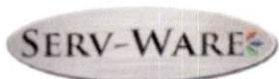

Serv-Ware  
www.servware.com

Phone:(800).768.5953

Fax:(800).976.1299

Revised 1/17

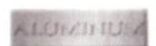

Item# \_\_\_\_\_  
Project: \_\_\_\_\_  
Qty: \_\_\_\_\_

# *Aluminum Dunnage Rack*

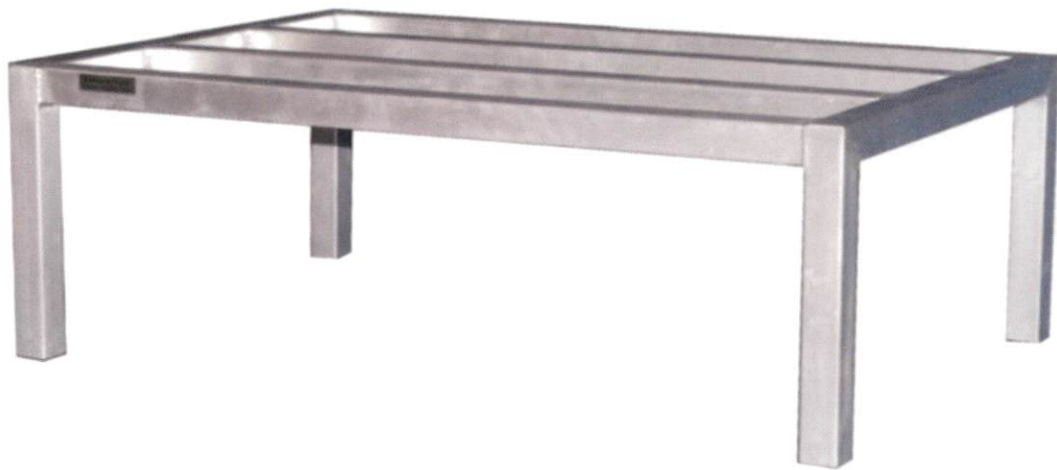

## **Features**

- Heavy Duty 1½" Square Aluminum all Welded Construction
- 1½" x 2" Angles
- For Use in Walk-in Coolers and Freezers, Dry Storage or Display
- Extends Product Life by Circulating Air Underneath
- Capacity 2,200 lbs. to 2,500 lbs.



Model:  
**GDM-49-HC~TSL01**

**Glass Door Merchandiser:**  
*Swing Door Refrigerator with Hydrocarbon Refrigerant~True Standard Look Version 01*



**STANDARD FEATURES**

**DESIGN**

- True's commitment to using the highest quality materials and oversized refrigeration systems provides the user with colder product temperatures, and lower utility costs in an attractive merchandiser that brilliantly displays packaged food and beverages.

**REFRIGERATION SYSTEM**

- Factory engineered, self-contained, capillary tube system using environmentally friendly R290 hydrocarbon refrigerant that has zero (0) ozone depletion potential (ODP), & three (3) global warming potential (GWP).
- High capacity, factory balanced refrigeration system that maintains cabinet temperatures of 33°F to 38°F (.5°C to 3.3°C) for the best in food preservation.
- State of the art, electronically commutated evaporator and condenser fan motors. ECM motors operate at higher peak efficiencies and move a more consistent volume of air which produces less heat, reduces energy consumption and provides greater motor reliability.
- Bottom mounted condensing unit positioned for easy maintenance. "No stoop" lower shelf maximizes visibility by raising merchandised product to higher level.

**CABINET CONSTRUCTION**

- Exterior - non-peel or chip black powder coated cold rolled steel; durable and permanent.
- Interior - attractive, NSF approved, white aluminum liner with stainless steel floor.

- Insulation - entire cabinet structure is foamed-in-place using a high density, polyurethane insulation that has zero ozone depletion potential (ODP) and zero global warming potential (GWP).
- Welded, heavy duty steel frame rail, black powder coated for corrosion protection.
- Frame rail fitted with leg levelers.
- Illuminated exterior sign panel. Variety of sign options available.

**DOORS**

- Double pane thermal insulated glass swing doors. Black powder coated frames.
- Each door fitted with 12" (305 mm) long extruded handle.
- Self closing doors. Positive seal, torsion type closure system.
- Magnetic door gaskets of one piece construction, removable without tools for ease of cleaning.

**SHELVING**

- Eight (8) adjustable, heavy duty PVC coated wire shelves 24 3/8" L x 22 1/2" D (624 mm x 572 mm). Four (4) chrome plated shelf clips included per shelf.
- Shelf support pilasters made of same material as cabinet interior; shelves are adjustable on 1/2" (13 mm) increments.

**LIGHTING**

- LED interior lighting provides more even lighting throughout the cabinet. Safety shielded.

**MODEL FEATURES**

- Evaporator is epoxy coated to eliminate the potential of corrosion.

- See our website [www.truemfg.com](http://www.truemfg.com) for latest color and sign offerings.
- Listed under NSF/ANSI Standard 7 for the storage and/or display of packaged or bottled product.

**ELECTRICAL**

- Unit completely pre-wired at factory and ready for final connection to a 115/60/1 phase, 15 amp dedicated outlet. Cord and plug set included.



115/60/1  
NEMA-5-15R

**OPTIONAL FEATURES/ACCESSORIES**

Upcharge and lead times may apply.

- White exterior.
- Stainless steel exterior.
- Black aluminum interior liner with black shelving.
- Stainless steel interior liner.
- 6" (153 mm) standard legs.
- 6" (153 mm) seismic/flanged legs.
- 2 1/2" (64 mm) diameter castors.
- 4" (102 mm) diameter castors.
- Wine racks.
- Additional shelves.
- TrueFlex gravity feed organizers.
- Pricing strips.
- Padlock.
- Barrel Locks located in grill assembly (requires one per door)

**PLAN VIEW**

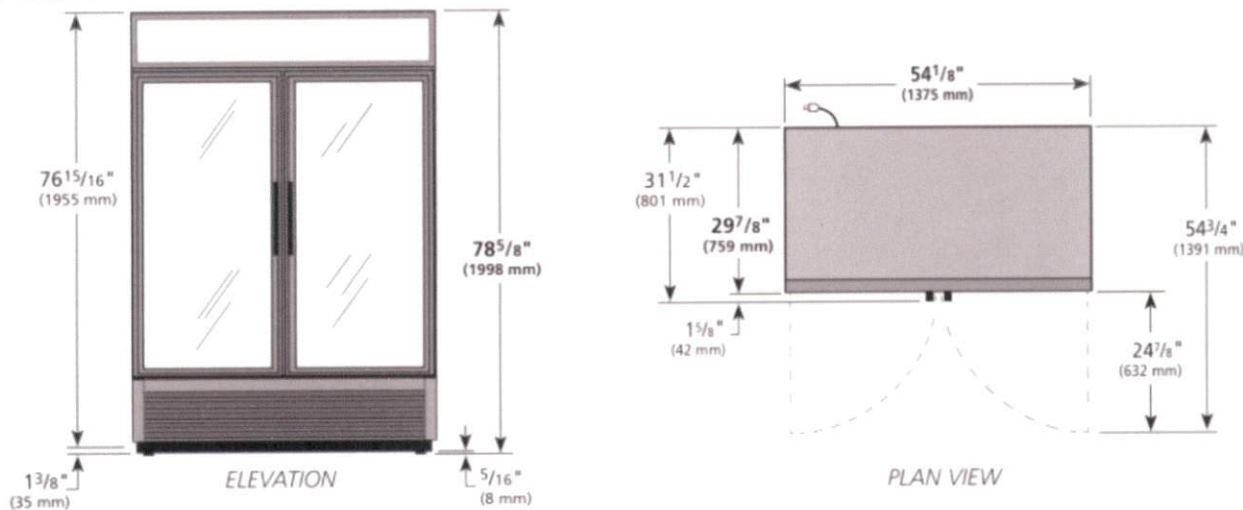

**WARRANTY**  
 Three year warranty on all parts and labor and an additional 2 year warranty on compressor. (U.S.A. only)

METRIC DIMENSIONS ROUNDED UP TO THE NEAREST WHOLE MILLIMETER  
 SPECIFICATIONS SUBJECT TO CHANGE WITHOUT NOTICE

	Model	Elevation	Right	Plan	3D	Back
	GDM-49-HC-TSL01					

**TRUE MANUFACTURING CO., INC.**



Project Name: \_\_\_\_\_

Location: \_\_\_\_\_

Item #: \_\_\_\_\_ Qty: \_\_\_\_\_

Model: \_\_\_\_\_

# ELECTRIC STEAM TABLES

- MODEL:  BVST-2-120  BVST-3-120  BVST-4-120  
 BVST-2-240  BVST-3-240  BVST-4-240  BVST-5-240

BevLes dry well steam tables are engineered for efficiency. Each well features a single formed calrod heating element with independent temperature control, designed to hold a variety of foods at precise serving temperature. Dry wells can be used with standard steam table pans or with optional spillage pans when additional moisture is needed.



BVST-2-120



BVST-3-120



BVST-4-120



BVST-5-240

## FEATURES AND CONSTRUCTION

- Heavy duty stainless steel top and well liners with 1" insulation on all four sides and bottom
- Each well provides precise individual infinite control
- Supplied with 8" wide x 1/2" thick polyethylene cutting board
- Well openings measure 12" x 20" x 8" deep
- Legs constructed of galvanized steel with adjustable feet
- Adjustable galvanized steel undershelf
- Red LED indicator lights display which wells are "ON"

## AVAILABLE OPTIONS

- TC5-5B – Four 5" diameter locking swivel casters
- BVWP – 12" x 20" spillage pan
- 12" Wide over shelf:
  - BVOS-12-2 12" Wide for 2 wells
  - BVOS-12-3 12" Wide for 3 wells
  - BVOS-12-4 12" Wide for 4 wells
  - BVOS-12-5 12" Wide for 5 wells
- 18" Wide over shelf:
  - BVOS-18-2 18" Wide for 2 wells
  - BVOS-18-3 18" Wide for 3 wells
  - BVOS-18-4 18" Wide for 4 wells
  - BVOS-18-5 18" Wide for 5 wells
- 12" Wide sneeze guard:
  - BVSG-12-2 12" Wide for 2 wells
  - BVSG-12-3 12" Wide for 3 wells
  - BVSG-12-4 12" Wide for 4 wells
  - BVSG-12-5 12" Wide for 5 wells
- 18" Wide sneeze guard:
  - BVSG-18-2 18" Wide for 2 wells
  - BVSG-18-3 18" Wide for 3 wells

## ELECTRIC

-120 Models: 120V / 60Hz / 1Ph

-240 Models: 208-230V / 50-60Hz / 1Ph



NEMA 5-15P



NEMA 5-20P



NEMA 5-30P



NEMA 6-20P



NEMA 6-30P

## 3RD PARTY APPROVALS







ATOSA USA, INC.

Toll Free: 855-855-0399 Email: [info@atosausa.com](mailto:info@atosausa.com)  
[www.atosa.com](http://www.atosa.com) / [www.atosausa.com](http://www.atosausa.com)  
 California, Colorado, Florida, Georgia, Illinois,  
 Massachusetts, New Jersey, Ohio, Texas, Washington

## MODELS:

ATMG-24 / ATMG- 36 / ATMG-48

# Manual Griddles

## Standard Features

- Stainless steel exterior & interior
- Stainless steel grease drawer
- Heavy duty 3/4" thick polished steel griddle plate
- 30,000 BTU Burners per 12" section with standby pilots
- Independent manual controls for each 12" section
- Stainless steel legs standard
- 3/4" NPT rear gas connection and regulator standard

ATMG-24



ATMG-36



ATMG-48

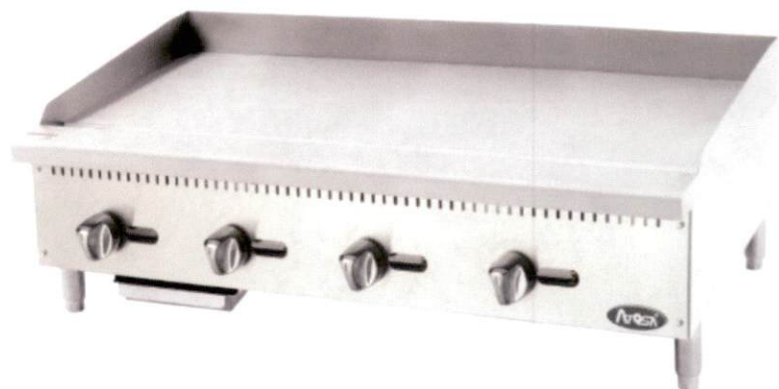

1 YR WARRANTY ON ALL PARTS AND LABOR (US ONLY)



Complies to ANSI  
 Z39.1-2004 (2011)  
 Certified to CSA



# Invoice



Cary Restaurant Equipment Inc  
 7050 Old Wake Forest Rd  
 Raleigh, NC 27616  
 Office Phone: 919-655-1376  
 sales@usedrestaurantequipmentnc.com

Invoice Number: 1220906545  
 Invoice Date: 09/06/2022  
 Payment Terms: Due On Receipt  
 Invoice Due Date: 09/06/2022  
 Invoice Amount: 21,910.48  
 Created By: Aziz Elqarnani

**Bill To**  
 Tortilleria & Rosticeria Don Chon  
 2116 W Cumberland St  
 Dunn, NC 28334  
 Office Phone: 919-264-4233

**Ship To**  
 Tortilleria & Rosticeria Don Chon  
 Office Phone: 919-264-4233

Item #	Item Name	Quantity	Unit Price	Taxable	Total
Winco-UT-16	Utility Tong Utility Tongs, 16", coiled spring, scalloped edge, heavy weight 0.9 millimeter stainless steel	3.00	3.99	X	11.97
BSON-15	BSON-15 Basting Spoon, 15" long, solid, one-piece, stainless steel, Prime, NSF (Qty Break = 12 each)	2.00	2.99	X	5.98
842169131047.00	winco BHPN-15	2.00	3.99	X	7.98
5398	LDIN-4 Ladle, 4 oz., one-piece, stainless steel, Prime, NSF (Qty Break = 12 each)	2.00	3.99	X	7.98
Winco LDIN-6	Ladle 6oz. Ladle, 6 oz. Stainless Steel, Prime, NSF	2.00	4.59	X	9.18
W5683	W5683 Turner, 8" x 3", stainless steel blade, molded white polypropylene handle, treated with sanitized antimicrobial protection, NSF	1.00	15.99	X	15.99
842169132594.00	Dough Cutter/ Scrapper White handle DSC-2W Dough Scraper, 6" x 3", stainless steel blade, white plastic handle, NSF	1.00	2.99	X	2.99
BP666	BP666 Take-A-Part Kitchen Shears, 8", stainless steel blades, black plastic handles (blister pack)	1.00	19.99	X	19.99
TMT-RF1	TMT-RF1 Refrigerator/Freezer Thermometer, tube style, temperature range -26°F to 86°F (-30°C to 30°C), 2-7/8" x 5/8" face, with suction cup, NSF (2 pieces per pack) (Qty Break = 12 pack)	2.00	6.99	X	13.98
FN-16	FN-16	1.00	4.99	X	4.99

*Makin de tortillas*



	French Whip, 16" long, stainless steel (Qty Break = 12 each)				
842169145907.00	Oven Mitt OMNP-15 15" oven mitt, Neoprene, Black	2.00	13.99	X	27.98
811642003133.00	Fry Pan AFP-7XC-H Gladiator Fry Pan, 7" dia., round, without lid, riveted handle, with blue silicone sleeve, scratch-resistant, aluminum, 3.5mm thick, PFOA-free, Excalibur non-stick coating, NSF	1.00	11.99	X	11.99
6364	wf14-cwp sink Faucet	1.00	58.99	X	58.99
Serv-Ware WFMK-CWP	Faucet, Parts Wall Mount Faucet Kit	1.00	15.99	X	15.99
Winco ALSP-10	10qt Alu Fryer/ Pasta pan	1.00	37.59	X	37.59
1737	used containers	4.00	5.00	X	20.00
6366	Used Bussing bin	2.00	3.00	X	6.00
6368	Used Scraper	1.00	8.00	X	8.00
6324	omcan 11367	2.00	24.99	X	49.98
Winco CBK-1520GR	Cutting Board STATIKBoard Cutting Board, 15" x 20" x 1/2" thick, rectangular, with rubber grip hook, dishwasher safe, BPA free, co-polymer, green, NSF	1.00	27.59	X	27.59
6205	CBK-1520RD Cutting board 15" x 20"	1.00	27.59	X	27.59
Winco SPSCH	Steam Table Pan Cover, SSH Steam Table Pan Cover, 1/2 Size, solid, with handle, 25-gauge standard weight, 18/8 stainless steel, NSF	2.00	5.99	X	11.98
1231	Used SS Pan	3.00	10.00	X	30.00
842169130477.00	Steam Table Pan Cover Winco C-HFC1	2.00	17.99	X	35.98
Winco SPJM-104	Steam Table Pan, SS Winco SPJM-104 Steam Table Pan, full size, 20-3/4" x 12-3/4" x 4" deep, 24 gauge, anti-jamming, 18/8 stainless steel, NSF	3.00	19.99	X	59.97
5205	SPJM-106 Steam Table Pan, full size, 20-3/4" x 12-3/4" x 6" deep, 24 gauge, anti-jamming, 18/8 stainless steel, NSF (Qty Break = 6 each)	2.00	24.99	X	49.98
842169109299.00	Water Spillage Pan Winco C-WPF6 Spillage Pan, Full-Size, 6", Upright Standing	4.00	25.00	X	100.00
31398	Omcan USA31398 (31398) Menu Chalk Board, natural color frame, includes chalks, markers, & eraser	1.00	65.99	X	65.99

2797	Used ingredient container	2.00	75.00	X	150.00
43373	Omcan USA 43373 (43373) Stock Pot, 60 quart, 16-1/2" diameter x 17-1/2" deep, dual handles, aluminum construction, NSF	1.00	159.99	X	159.99
842169146706.00	Manual Can opener Winco CO-3N Manual Can Opener, Heavy Duty, 19" Table Mounting.	1.00	139.99	X	139.99
Winco SPJM-204	Steam Table Pan, SS NEEDS THIS Steam Table Pan, 1/2 size, 10-3/8" x 12-3/4" x 4" deep, 24 gauge, anti-jamming, 18/8 stainless steel, NSF	3.00	12.99	X	38.97
Ser-Ware CWP-DR-246012	Dunage Rack	3.00	84.59	X	253.77
6367	mrs-3-d	1.00	970.00	X	970.00
6365	True Used Cooler 1-4827811	1.00	2,000.00	X	2,000.00
6369	USed Crathco for Drinkf	1.00	550.00	X	550.00
6370	USed Tables (Redish/Brown)	5.00	25.00	X	125.00
6371	USed SS Equipment Stand Table	1.00	180.00	X	180.00
Atosa AGR-6B-NG	CookRite Range 36" 6 Burner NG CookRite Range, Natural gas, 36"W x 31"D x 57-3/8"H, (6) 32,000 BTU open burners, removable cast iron top grates, (1) 26-1/2"W oven, (2) adjustable chrome oven racks, pilot light, drip tray, stainless steel front, back sides, kick plate, back guard & over shelf, (4) casters, 219,000 total BTU's, cETLus, ETL-Sanitation	1.00	1,940.00	X	1,940.00
6372	Used Saba Fryer	1.00	600.00	X	600.00
Atosa ATMG-24	Gas Countertop Griddle CookRite Heavy Duty Griddle, gas, countertop, 24"W x 28-3/5"D x 15-1/5"H, (23-9/10"W x 19-9/10"D cooking area), 3/4" thick griddle plate, (2) stainless steel burners, standby pilots, independent manual controls, stainless steel structure, adjustable stainless steel legs, 60,000 total BTU's, cETLus, ETL-Sanitation	1.00	870.00	X	870.00
5538	ER2A-FS Two Door Stainless Steel Refrigerator	1.00	3,170.00	X	3,170.00
EF2A-FS	EF2A-FS Economy Series Freezer, reach-in, two-section, 38.54 cu. ft., bottom mounted self-contained refrigeration, (6) adjustable epoxy coated shelves, (2) full-height solid hinged doors with locks, digital temperature display/controls, temperature alarms, LED interior lighting, stainless steel interior floor, aluminum interior sides, rear, & top, stainless steel front, gray painted steel exterior sides, top & rear, (6) 4" casters (2 with brakes), R290 Hydrocarbon refrigerant, 1/2 HP, NEMA 5-15P, UL EPH Classified, cULus Warranty: 2-Year parts & labor on entire machine Warranty: 5-Year parts on compressor 115v/60/1-ph, 4.7 amps, standard	1.00	3,700.00	X	3,700.00



Atosa YR280-AP-161	Ice Maker with Bin, Cube-Style Ice Maker with Bin, cube-style, air-cooled, self-contained condenser, 23.7"W x 28.5"D x 38.6"H, production capacity up to 283-lb/24 hours, 88 lb storage capacity, stainless steel exterior, 6" adjustable legs, includes: ice scoop, removable air filter, includes: 3M ICE120-S Water Filter System, R290 Hydrocarbon refrigerant, 115v/60/1-ph, 7.2 amps, cETLus, ETL-Sanitation, NSF, ENERGY STAR (drain required)	1.00	2,520.00	X	2,520.00
BVST-4-240	Hot Food Serving Counter / Table Steam Table, electric, dry heat, 58"W x 22"D x 34"H, (4) open pan wells, Calrod heating elements per well, individual infinite temperate controls, LED indicator light, polyethylene cutting board, undershelf, stainless steel top and well liners, galvanized steel undershelf & legs, adjustable feet, 4000 watts, 208-230v/50-60/1-ph, cord, NEMA 6-30P, cETLus, ETL-Sanitation	1.00	1,300.00	X	1,300.00
BVSG-18-4	Hot Food Serving Counter / Table Sneezeguard, 18"W, for (4) well steam table	1.00	500.00	X	500.00
Atosa SSTW-3072	Work Table, Stainless Steel Top MixRite Work Table, 72"W x 30"D x 34"H, 18/430 stainless steel top with turned down edges, adjustable stainless steel undershelf, stainless steel legs, adjustable bullet feet, NSF, KD	1.00	515.00	X	515.00

Subtotal: \$ 20,429.35  
NC Rate: 7.25%  
NC Amount: 1,481.13  
**Invoice Amount \$ 21,910.48**  
Check #101 on 09/06/2022: (21,910.48)  
**Invoice Balance: \$ 0.00**

**Terms & Conditions:**

Delivery Fee is to the front door only. Any additional installation requests will be billed at \$55.00 for up to first hour. Any damage resulting from installation is the sole responsibility of the customer. (removal of wheels, manually having to carry the unit, Stairs, etc...)

It is the customers responsibility to make sure the unit purchased will fit.

All unused returns will be subjected to restocking fees of 25%.

All returns must be returned within 7 days from the pickup or the delivery day.

We only accept unused items. No returns on special ordered items.

All new equipment come with manufacture warranty.

All used refrigeration equipment come with 30 day warranty parts and labor.

Warranty Not valid on Discounted or sale items.

# Invoice



Cary Restaurant Equipment Inc  
7050 Old Wake Forest Rd  
Raleigh, NC 27616  
Office Phone: 919-655-1376  
sales@usedrestaurantequipmentnc.com

Invoice Number: 1220906546  
Invoice Date: 09/06/2022  
Payment Terms: Due On Receipt  
Invoice Due Date: 09/06/2022  
Invoice Amount: 2,574.00  
Created By: Aziz Elqarnani

**Bill To**  
Tortilleria & Rosticeria Don Chon  
2116 W Cumberland St  
Dunn, NC 28334  
Office Phone: 919-264-4233

**Ship To**  
Tortilleria & Rosticeria Don Chon  
Office Phone: 919-264-4233

Item #	Item Name	Quantity	Unit Price	Taxable	Total
Atosa MSF8302GR	Sandwich / Salad Preparation Refrigerator Atosa Sandwich/Salad Top Refrigerator, two-section, 48-1/5"W x 30"D x 44-3/10"H, includes (12) 1/6 stainless steel pans, rear-mounted, self-contained refrigeration, 13.4 cu. ft., (2) solid hinged self-closing doors, digital temperature control, 33°F to 40°F temperature range, (2) adjustable shelves, 10" poly cutting board, ventilated refrigeration, automatic evaporation, air defrost, stainless steel interior & exterior, galvanized steel back, 5" casters, R290 Hydrocarbon refrigerant, 1/7 HP, 115v/60/1-ph, 2.3 amps, cord, NEMA 5-15P, cETLus, ETL-Sanitation	1.00	2,400.00	X	2,400.00

Subtotal: \$ 2,400.00  
NC Rate: 7.25%  
NC Amount: 174.00  
**Invoice Amount \$ 2,574.00**  
Check #102 on 09/06/2022: (2,574.00)  
**Invoice Balance: \$ 0.00**

### Terms & Conditions:

Delivery Fee is to the front door only. Any additional installation requests will be billed at \$55.00 for up to first hour. Any damage resulting from installation is the sole responsibility of the customer. (removal of wheels, manually having to carry the unit, Stairs, etc...)

It is the customers responsibility to make sure the unit purchased will fit.

All unused returns will be subjected to restocking fees of 25%.

All returns must be returned within 7 days from the pickup or the delivery day.

We only accept unused items. No returns on special ordered items.

All new equipment come with manufacture warranty.

All used refrigeration equipment come with 30 day warranty parts and labor.

Warranty Not valid on Discounted or sale items.



# Invoice

Cary Restaurant Equipment Inc  
 7050 Old Wake Forest Rd  
 Raleigh, NC 27616  
 Office Phone: 919-655-1376  
 caryused@gmail.com

Invoice Number: 1220906545  
 Invoice Date: 09/06/2022  
 Payment Terms: Due On Receipt  
 Invoice Due Date: 09/06/2022 (Past Due)  
 Invoice Amount: 22,700.90  
 Created By: Aziz Elqarnani

**Bill To**  
 Tortilleria & Rosticeria Don Chon  
 2116 W Cumberland St  
 Dunn, NC 28334  
 Office Phone: 919-264-4233

**Ship To**  
 Tortilleria & Rosticeria Don Chon  
 Office Phone: 919-264-4233

Item #	Item Name	Quantity	Unit Price	Taxable	Total
Winco-UT-16	Utility Tong Utility Tongs, 16", coiled spring, scalloped edge, heavy weight 0.9 millimeter stainless steel	3.00	3.99	X	11.97
BSON-15	BSON-15 Basting Spoon, 15" long, solid, one-piece, stainless steel, Prime, NSF (Qty Break = 12 each)	2.00	2.99	X	5.98
842169131047.00	winco BHPN-15	2.00	3.99	X	7.98
5398	LDIN-4 Ladle, 4 oz., one-piece, stainless steel, Prime, NSF (Qty Break = 12 each)	2.00	3.99	X	7.98
Winco LDIN-6	Ladle 6oz. Ladle, 6 oz. Stainless Steel, Prime, NSF	2.00	4.59	X	9.18
W5683	W5683 Turner, 8" x 3", stainless steel blade, molded white polypropylene handle, treated with sanitized antimicrobial protection, NSF	1.00	15.99	X	15.99
842169132594.00	Dough Cutter/ Scrapper White handle DSC-2W Dough Scraper, 6" x 3", stainless steel blade, white plastic handle, NSF	1.00	2.99	X	2.99
BP666	BP666 Take-A-Part Kitchen Shears, 8", stainless steel blades, black plastic handles (blister pack)	1.00	19.99	X	19.99

TMT-RF1	TMT-RF1 Refrigerator/Freezer Thermometer, tube style, temperature range -26°F to 86°F (-30°C to 30°C), 2-7/8" x 5/8" face, with suction cup, NSF (2 pieces per pack) (Qty Break = 12 pack)	2.00	6.99	X	13.98
FN-16	FN-16 French Whip, 16" long, stainless steel (Qty Break = 12 each)	1.00	4.99	X	4.99
842169145907.00	Oven Mitt OMNP-15 15" oven mitt, Neoprene, Black	2.00	13.99	X	27.98
811642003133.00	Fry Pan AFP-7XC-H Gladiator Fry Pan, 7" dia., round, without lid, riveted handle, with blue silicone sleeve, scratch-resistant, aluminum, 3.5mm thick, PFOA-free, Excalibur non-stick coating, NSF	1.00	11.99	X	11.99
Serv-Ware WFMK-CWP	Faucet, Parts Wall Mount Faucet Kit	1.00	15.99	X	15.99
Winco ALSP-10	10qt Alu Fryer/ Pasta pan	1.00	37.59	X	37.59
1737	used containers	4.00	5.00	X	20.00
6366	Used Bussing bin	2.00	3.00	X	6.00
6368	Used Scraper	1.00	8.00	X	8.00
6324	omcan 11367	2.00	24.99	X	49.98
Winco CBK-1520GR	Cutting Board STATIKBoard Cutting Board, 15" x 20" x 1/2" thick, rectangular, with rubber grip hook, dishwasher safe, BPA free, co-polymer, green, NSF	1.00	27.59	X	27.59
6205	CBK-1520RD Cutting board 15" x 20"	1.00	27.59	X	27.59
Winco SPSCH	Steam Table Pan Cover, SS H Steam Table Pan Cover, 1/2 Size, solid, with handle, 25-gauge standard weight, 18/8 stainless steel, NSF	2.00	5.99	X	11.98
1231	Used SS Pan	3.00	10.00	X	30.00
842169130477.00	Steam Table Pan Cover Winco C-HFC1	2.00	17.99	X	35.98
Winco SPJM-104	Steam Table Pan, SS Winco SPJM-104 Steam Table Pan, full size, 20-3/4" x 12-	3.00	19.99	X	59.97



	3/4" x 4" deep, 24 gauge, anti-jamming, 18/8 stainless steel, NSF				
5205	SPJM-106 Steam Table Pan, full size, 20-3/4" x 12-3/4" x 6" deep, 24 gauge, anti-jamming, 18/8 stainless steel, NSF (Qty Break = 6 each)	2.00	24.99	X	49.98
842169109299.00	Water Spillage Pan Winco C-WPF6 Spillage Pan, Full-Size, 6", Upright Standing	4.00	25.00	X	100.00
31398	Omcan USA31398 (31398) Menu Chalk Board, natural color frame, includes chalks, markers, & eraser	1.00	65.99	X	65.99
2797	Used ingredient container	2.00	75.00	X	150.00
43373	Omcan USA 43373 (43373) Stock Pot, 60 quart, 16-1/2" diameter x 17-1/2" deep, dual handles, aluminum construction, NSF	1.00	159.99	X	159.99
842169146706.00	Manual Can opener Winco CO-3N Manual Can Opener, Heavy Duty, 19" Table Mounting.	1.00	139.99	X	139.99
Winco SPJM-204	Steam Table Pan, SS NEEDS THIS Steam Table Pan, 1/2 size, 10-3/8" x 12-3/4" x 4" deep, 24 gauge, anti-jamming, 18/8 stainless steel, NSF	3.00	12.99	X	38.97
Ser-Ware CWP-DR-246012	Dunage Rack	3.00	84.59	X	253.77
6367	mrs-3-d	1.00	970.00	X	970.00
6365	True Used Cooler 1-4827811	1.00	2,000.00	X	2,000.00
6369	USed Crathco for Drinkf	1.00	550.00	X	550.00
6370	USed Tables (Redish/Brown)	5.00	25.00	X	125.00
6371	USed SS Equipment Stand Table	1.00	180.00	X	180.00
Atosa AGR-6B-NG	CookRite Range 36" 6 Burner NG CookRite Range, Natural gas, 36"W x 31"D x 57-3/8"H, (6) 32,000 BTU open burners, removable cast iron top grates, (1) 26-1/2"W oven, (2) adjustable chrome oven racks, pilot light, drip tray, stainless steel front, back sides, kick plate, back guard & over shelf, (4) casters, 219,000 total BTU, cETLus, ETL-Sanitation	1.00	1,940.00	X	1,940.00

6372	Used Saba Fryer	1.00	600.00	X	600.00
Atosa ATMG-24	Gas Countertop Griddle CookRite Heavy Duty Griddle, gas, countertop, 24"W x 28-3/5"D x 15-1/5"H, (23-9/10"W x 19-9/10"D cooking area), 3/4" thick griddle plate, (2) stainless steel burners, standby pilots, independent manual controls, stainless steel structure, adjustable stainless steel legs, 60,000 total BTU's, cETLus, ETL-Sanitation	1.00	870.00	X	870.00
5538	ER2A-FS Two Door Stainless Steel Refrigerator	1.00	3,170.00	X	3,170.00
EF2A-FS	EF2A-FS Economy Series Freezer, reach-in, two-section, 38.54 cu. ft., bottom mounted self-contained refrigeration, (6) adjustable epoxy coated shelves, (2) full-height solid hinged doors with locks, digital temperature display/controls, temperature alarms, LED interior lighting, stainless steel interior floor, aluminum interior sides, rear, & top, stainless steel front, gray painted steel exterior sides, top & rear, (6) 4" casters (2 with brakes), R290 Hydrocarbon refrigerant, 1/2 HP, NEMA 5-15P, UL EPH Classified, cULus Warranty: 2-Year parts & labor on entire machine Warranty: 5-Year parts on compressor 115v/60/1-ph, 4.7 amps, standard	1.00	3,700.00	X	3,700.00
Atosa YR280-AP-161	Ice Maker with Bin, Cube-Style Ice Maker with Bin, cube-style, air-cooled, self-contained condenser, 23.7"W x 28.5"D x 38.6"H, production capacity up to 283-lb/24 hours, 88 lb storage capacity, stainless steel exterior, 6" adjustable legs, includes: ice scoop, removable air filter, includes: 3M?? ICE120-S Water Filter System, R290 Hydrocarbon refrigerant, 115v/60/1-ph, 7.2 amps, cETLus, ETL-Sanitation, NSF, ENERGY STAR?? (drain required)	1.00	2,520.00	X	2,520.00
BVST-4-240	Hot Food Serving Counter / Table Steam Table, electric, dry heat, 58"W x 22"D x 34"H, (4) open pan wells, Calrod heating elements per well, individual infinite temperate controls, LED indicator light, polyethylene cutting board, undershelf, stainless steel top and well	1.00	1,300.00	X	1,300.00



	liners, galvanized steel undershelf & legs, adjustable feet, 4000 watts, 208-230v/50-60/1-ph, cord, NEMA 6-30P, cETLus, ETL-Sanitation				
BVSG-18-4	Hot Food Serving Counter / Table Sneezeguard, 18"W, for (4) well steam table	1.00	500.00	X	500.00
Atosa SSTW-3072	Work Table, Stainless Steel Top MixRite Work Table, 72"W x 30"D x 34"H, 18/430 stainless steel top with turned down edges, adjustable stainless steel undershelf, stainless steel legs, adjustable bullet feet, NSF, KD	1.00	515.00	X	515.00
6432	ServWare Add-On AF-18DJ-CWP	1.00	57.00	X	57.00
BKF-VSMPR-WB-G	BK Resources BKF-VSMPR-WB-G WorkForce Pre-Rinse Assembly, splash-mounted, 8" OC, triple ply hose, 12" wall bracket, 1/4 turn ceramic valves, 1/2" female inlets, lead free 1 year warranty, standard	1.00	319.99	X	319.99
44372	Omcan USA 44372 (44372) Display Case, countertop, curved front glass, 21.8"W x 14.8"D x 14.8"H, 45L capacity, attendant serve, rear hinged door, (1) shelf, non-refrigerated, glass and stainless steel construction	1.00	399.99	X	399.99
6433	Soup Bowl	18.00	0.50	X	9.00
6434	Used Tortilla Holder	5.00	2.00	X	10.00

paid check # 108  
\$ 790.42

Subtotal: \$ 21,166.34  
 NC Rate: 7.25%  
 NC Amount: 1,534.56  
**Invoice Amount \$ 22,700.90**  
 Check #101 on 09/06/2022: (21,910.48)  
**Invoice Balance: \$ 790.42**

**Terms & Conditions:**

Delivery Fee is to the front door only. Any additional installation requests will be billed at \$55.00 for up to first hour. Any damage resulting from installation is the sole responsibility of the customer, (removal of wheels, manually having to carry the unit, Stairs, etc...)

It is the customers responsibility to make sure the unit purchased will fit.

All unused returns will be subjected to restocking fees of 25%.

All returns must be returned within 7 days from the pickup or the delivery day.

We only accept unused items. No returns on special ordered items.

All new equipment come with manufacture warranty.

All used refrigeration equipment come with 30 day warranty parts and labor.

Warranty Not valid on Discounted or sale items.