



# Halifax FTHP530 Type 1 Concession Trailer / Food Truck Hood System - 5' x 30"

Item #421FTHP530

## Technical Data

Length	5 Feet
Depth	30 Inches
Fire Suppression	Optional Fire Suppression
Made in America	Yes
Plug Type	Hardwire
Style	Food Truck Hood Systems
Type	Type 1

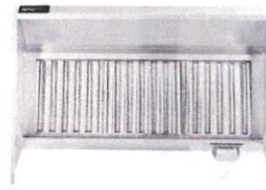

## Features

- o Type 1 hood for grease-producing equipment; exhaust-only system with no makeup air
- o Includes sloped-front hood canopy and exhaust fan
- o 18-gauge 430 stainless steel construction on all exposed surfaces
- o For food truck and concession trailer installations
- o 115V direct-drive exhaust fan (1000 CFM)

## Certifications



## Plan View

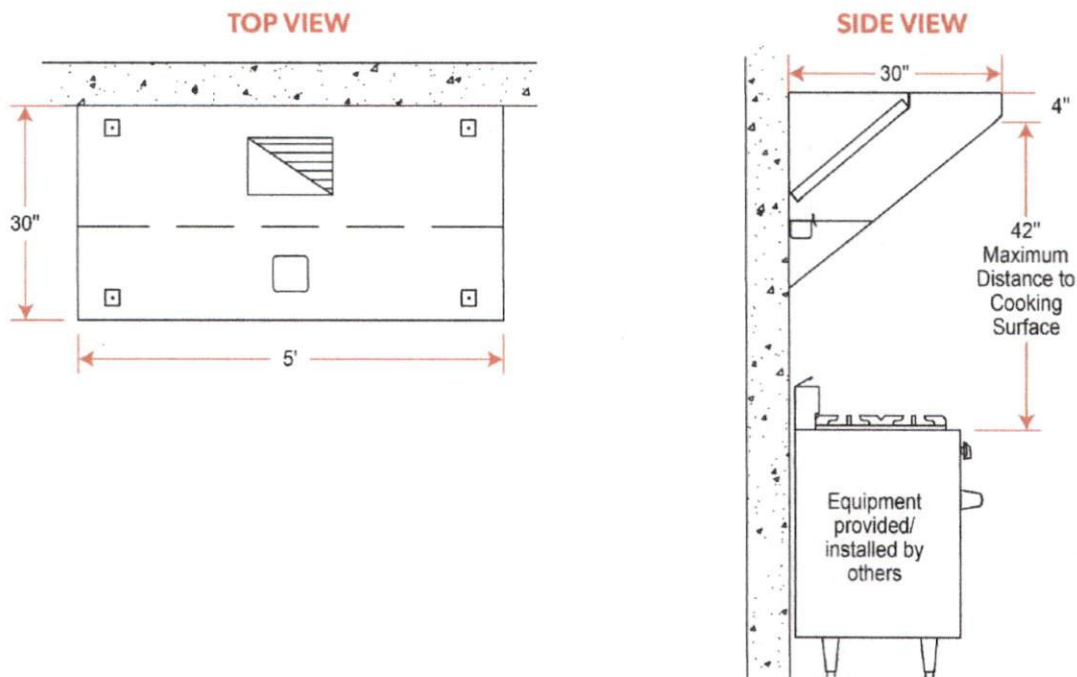

## Notes & Details

Keep your kitchen free of hazardous grease buildup with this Halifax FTHP530 5' x 30" type 1 concession trailer / food truck hood system. This unit is suitable for use over any equipment that has a surface operating temperature under 700 degrees Fahrenheit, and that is required by fire code to have a type 1 hood when installed in a food truck or concession trailer - this includes fryers, griddles, charbroilers, conveyor pizza ovens, or any equipment that produces grease during the cooking process. The hood removes the grease-laden vapors produced by your equipment and prevents them from accumulating in places where they could become a fire or sanitation hazard, leaving your kitchen clean and safe to use! It is an exhaust-only system with no makeup or supply fan and also contains a 115V direct-drive exhaust fan designed for 1000 CFM. To make installation easy, it also includes a 2" high concession curb for the fan, a 12" length of duct work, a curb plate, and 12" x 9" side curtains. A variable dial control makes it easy to adjust the fan speed as needed to account for higher or lower ventilation needs.

The hood uses (3) 20" x 20" baffle-type filters, and the filters are made from stainless steel to provide durability and make cleaning easy. Grease extracted by the filter is collected in a grease trough, which drains into a stainless steel grease cup for disposal. 18-gauge 430 stainless steel is used on all exposed surfaces to give it excellent durability and cleanability, while the MIG-welded frame provides seamless, liquid-tight joints. The hood features a sloped-front canopy design that is great for low ceilings, providing extra front clearance and comfort for chefs, and dropping down close to the equipment in the back.

2 pre-wired lights (sent loose or installed) illuminate the equipment under your hood so that you can easily see what you're doing while cooking, and they require a 115V electrical connection to the junction box. The smooth top on this hood is great for tight installations because it allows maximum clearance. 4 hanger brackets can be included at your option to make installation easy. It must be hard-wired, cords and plugs are not included.

**WARNING:** This product can expose you to chemicals including lead, which are known to the State of California to cause cancer, birth defects, or other reproductive harm. For more information, go to [www.p65warnings.ca.gov](http://www.p65warnings.ca.gov).

## 30" Electric Countertop Griddle

### ITEM NUMBER

#177EG30N

### SPECIAL FEATURES

- Stainless steel housing
- Stainless steel feet that are adjustable from 3½" to 5½"
- Adjustable temperature range of 150-570°F
- 3" steel splashguards on sides and back
- 208/240V, 1 Phase; 3375-4500W

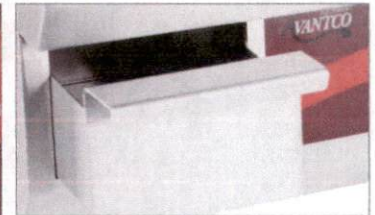
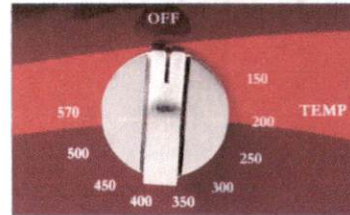

### RECOMMENDED COMPANION PRODUCTS

Item Number	Product Description
147FORMULAD	Noble Chemical Formula-D Decarbonizer and Degreaser
181GS6	Garde Grill Scraper
579GRILLGEAR	Griddle Gear Cleaning Kit
147QPGRIDDLE	Noble Chemical Griddle Kleen Packets

### TECHNICAL DATA

Dimensions	30½" x 19¾" x 13"-15"
Cooking Surface Dimensions	30"W x 15½"D
Number of Burners	3
Controls	Thermostatic
Temperature Range	150-570°F
Wattage	3375-4500W
Hertz	60
Voltage	208/240V
Amps	16.23-18.75



Intertek



6-20P

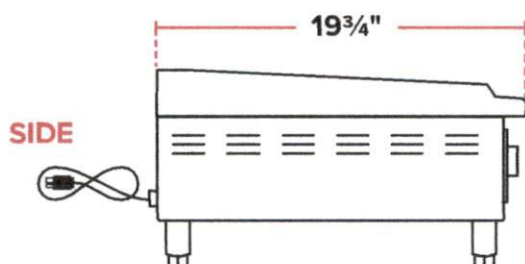
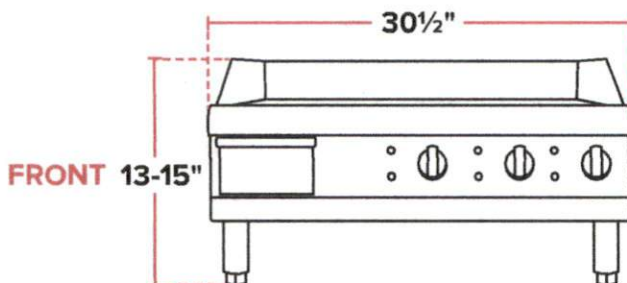

SIDE



FRONT



1. Name of the object: \_\_\_\_\_  
 2. Material: \_\_\_\_\_  
 3. Scale: \_\_\_\_\_  
 4. Date: \_\_\_\_\_  
 5. Signature: \_\_\_\_\_  
 6. Roll No.: \_\_\_\_\_



1. The object is a rectangular block with a cylindrical hole through its center.  
 2. The drawing shows the object from the front and side views.  
 3. The front view shows the rectangular shape with a circular hole in the center.  
 4. The side view shows the rectangular shape with a dashed line indicating the hidden edge of the hole.

1. The object is a rectangular block with a cylindrical hole through its center.

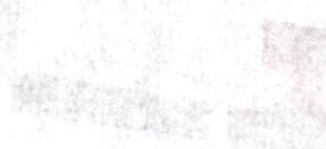

1. The object is a rectangular block with a cylindrical hole through its center.  
 2. The drawing shows the object from the front and side views.  
 3. The front view shows the rectangular shape with a circular hole in the center.  
 4. The side view shows the rectangular shape with a dashed line indicating the hidden edge of the hole.

1. The object is a rectangular block with a cylindrical hole through its center.

1. The object is a rectangular block with a cylindrical hole through its center.

1. The object is a rectangular block with a cylindrical hole through its center.

1. The object is a rectangular block with a cylindrical hole through its center.

1. The object is a rectangular block with a cylindrical hole through its center.

1. The object is a rectangular block with a cylindrical hole through its center.

1. The object is a rectangular block with a cylindrical hole through its center.



B



# Countertop Electric Range

## CER-200 Dual Solid French-Style Burner

### ITEM NUMBER

#177CER200

### SPECIAL FEATURES

- Features dual 9" round french-style cast iron element plates that can safely accommodate up to a 40 qt. stockpots
- Independent infinite controls allow for a maximum plate temperature of 800°F
- Heats up to 650°F in just 10 minutes
- Stainless steel housing with an attractive bull-nose front and with bullet feet that adjust from 3½" to 5" high
- 208/240V, 3,000-4,000W

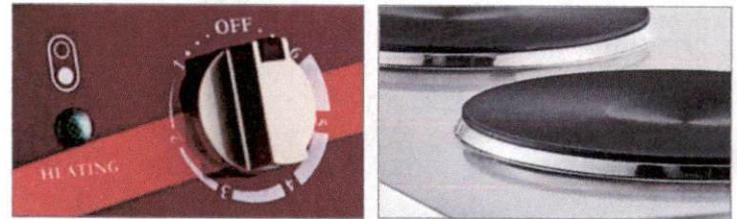

### RECOMMENDED COMPANION PRODUCTS

Item Number	Product Description
999EXCEL	Noble Chemical Excel Stainless Steel Cleaner / Metal Polish
473SSPOT20	Vigor 20 Qt. Heavy-Duty Stainless Steel Aluminum-Clad Stock Pot with Cover

### TECHNICAL DATA

Width	15"
Depth	25"
Height	11¼"
Burner Diameter	9"
Voltage	208/240V
Wattage	3,000-4,000W
Control Type	Infinite
Number of Burners	2
Power Type	Electric

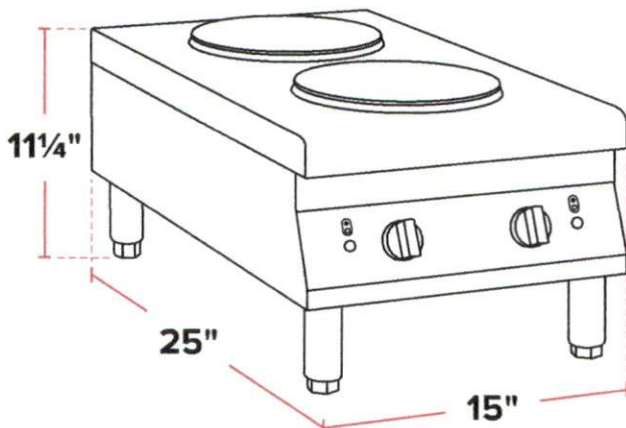

PROJECT: \_\_\_\_\_ **D**

MODEL: \_\_\_\_\_

ITEM #: \_\_\_\_\_ QUANTITY: \_\_\_\_\_

APPROVAL: \_\_\_\_\_ DATE: \_\_\_\_\_

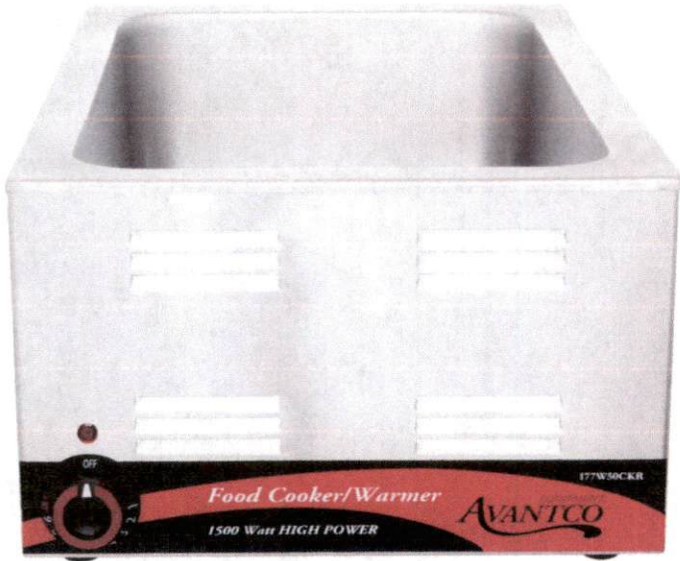

## Full Size Electric Countertop Food Cooker/Warmer

### ITEM NUMBER

#177W50CKR

### SPECIAL FEATURES

- Cooks and holds your products at foodsafe temperatures
- Durable stainless steel food well
- Holds a full size 12" x 20" food pan or fractional size food pans (sold separately)
- 120-212°F temperature range; reaches 212°F in less than 30 minutes



### TECHNICAL DATA

Interior Dimensions	12" x 20" x 6¼"
Exterior Dimensions	14½" x 22½" x 9¼"
Temperature Range	120-212°F
Voltage	120V
Wattage	1500W
Hertz	60Hz
Amps	12.5 Amps
Phase	1



5-15P

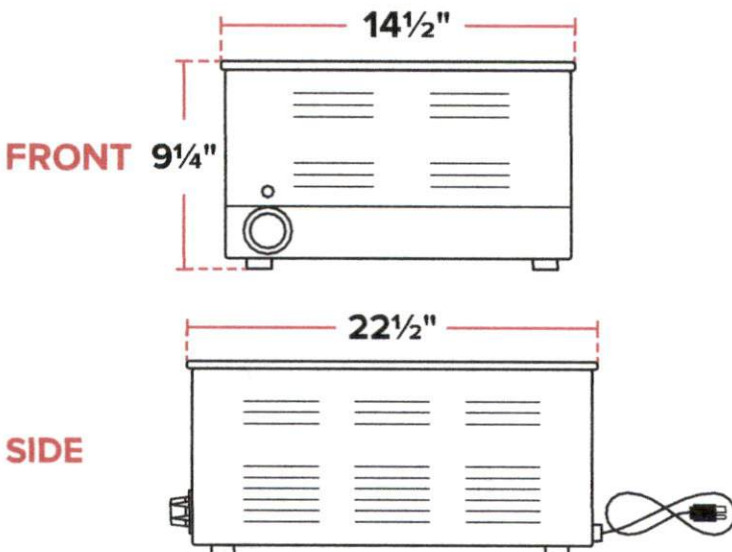



www.AvantcoRefrigeration.com

PROJECT: \_\_\_\_\_ **E**

MODEL: \_\_\_\_\_

ITEM #: \_\_\_\_\_ QUANTITY: \_\_\_\_\_

APPROVAL: \_\_\_\_\_ DATE: \_\_\_\_\_

# SSPT Series Salad/Sandwich Prep Table MEGA TOP

MODEL #178SSPT48MHC

## SSPT SERIES - SANDWICH & SALAD PREP

Ample prep space to create subs, salads, and sandwiches with convenient cold ingredient storage

### CABINET CONSTRUCTION

Heavy duty construction includes 430 type stainless steel exterior with a 304 type stainless steel interior and an overall 35¼" working height.

Foamed-in-place CFC- and HCFC-free polyurethane insulation enhances the structural strength of the cabinet and helps increase energy efficiency. Insulated lid helps maintain safe product temperatures.

Full length, 8" deep cutting board for easy prep work.

Easy-to-use recessed full-length stainless steel handles. Door stays open past 90° for easy loading, but will self-close under 90° to save energy.

### REFRIGERATION SYSTEM

Environmentally safe R290 refrigerant. Rear-mounted condensing unit positioned for easy maintenance.

### SHELVING

2 epoxy-coated wire shelves accommodate up to 90 lb. each.

### MODEL FEATURES

Preprogrammed digital controller features auto-defrost function.

Top pan rail holds up to (18) 1/6 size, 6" deep food pans. Pan rail is air cooled from the bottom.

## SPECIAL FEATURES

- Eco-friendly R290 hydrocarbon refrigerant
- Top holds up to (18) 1/6 size, 6" deep food pans (sold separately)
- Full length, 3/4" thick, 8" deep cutting board for easy prep work
- Insulated lid helps maintain safe product temperatures
- Double self-closing swing doors with recessed full-length stainless steel handles
- 2 epoxy coated wire shelves
- 430 type stainless steel exterior and 304 type stainless steel interior
- Digital temperature controls hold at 33-40°F
- 115V, 1/4 hp
- Pan rail is air cooled from the bottom



## WARRANTY

RESIDENTIAL: Avantco assumes no liability for parts or labor coverage for component failure, factory defect or any other damages for units installed in non-commercial foodservice or residential applications.



Parts & Labor



Compressor

10/2020 Intertek Intertek

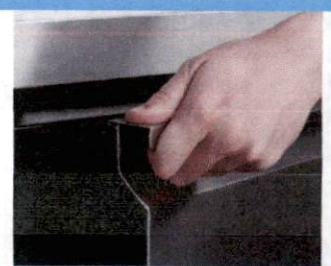
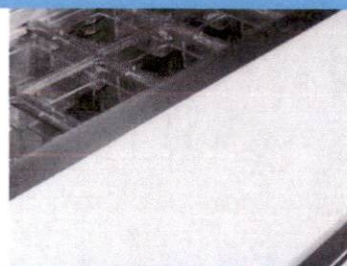

# SSPT Series

## Salad/Sandwich Prep Table

### MEGA TOP

MODEL #178SSPT48MHC



www.AvantcoRefrigeration.com

#### TECHNICAL DATA

##### Dimensions

Exterior Dimensions	46 <sup>3</sup> / <sub>4</sub> "W x 35"D x 45 <sup>7</sup> / <sub>8</sub> "H
Interior Dimensions	42 <sup>7</sup> / <sub>8</sub> "W x 23 <sup>3</sup> / <sub>4</sub> "D x 23 <sup>1</sup> / <sub>2</sub> "H
Working Height	35 <sup>1</sup> / <sub>4</sub> "
Overall Height (Lid Open)	51 <sup>3</sup> / <sub>4</sub> "
Net Volume	12 cu. ft.
Net Weight	319 lb.
Gross Weight	374 lb.
Packaging Dimensions	51"W x 39 <sup>1</sup> / <sub>4</sub> "D x 49"H

##### Construction

Exterior Material	Type 430 Stainless Steel
Interior Material	Type 304 Stainless Steel
Insulation Material	Foamed-in -place polyurethane
Shelf Size	(2) 20 <sup>3</sup> / <sub>4</sub> " x 17 <sup>1</sup> / <sub>16</sub> "
Shelf Material	Epoxy-coated steel
Shelf Load Capacity	90 lb.

##### Cooling

Temperature Range	33°F - 40°F
Refrigerant	R290
Max. Ambient Temperature	90°F
Defrosting	Automatic
Temperature Controller	Digital
Horsepower	1/4

##### Electrical

Voltage	115
Amps	7.8
Hz	60
Phase	1
Plug Type	NEMA 5-15P
Electrical Cord Length	84"

#### PLAN VIEW

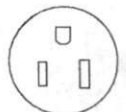
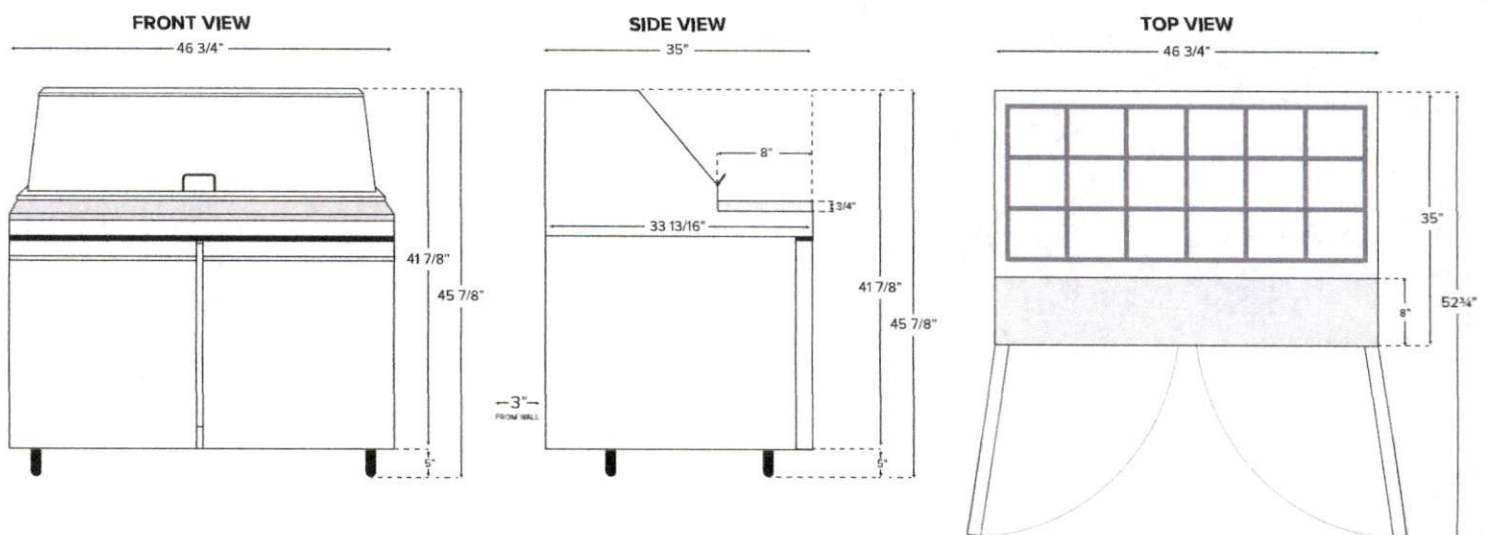

NEMA 5-15P



## Galaxy CF10HC Commercial Chest Freezer - 9.6 cu. ft.

Item #177CF10HC

### Special Features

- Durable aluminum interior, painted steel exterior; 9.6 cu. ft. of interior storage space with lock
- Foamed in place polyurethane insulation helps maintain performance even in 100 degree ambient
- Includes 1 epoxy-coated steel basket with a weight capacity of 33 lb.
- Designed and NSF-7 certified by ETL for commercial use to provide reliability, durability, and ease of use
- 1/5 hp; uses eco-friendly R600a refrigerant

### Technical Data

Width	40 5/8 Inches
Depth	29 3/4 Inches
Height	33 Inches
Interior Width	34 5/8 Inches
Interior Depth	20 5/8 Inches
Interior Height	25 1/2 Inches
Amps	1.5 Amps
Hertz	60 Hertz
Voltage	115 Volts
Wattage	172.5 Watts
Capacity	9.6 cu. ft.
Door Style	Swing
Door Type	Solid
Horsepower	1/5 HP
Number of Doors	1 Doors
Plug Type	NEMA 5-15P
Refrigerant Type	R-600a
Temperature Range	0 - 8 Degrees F



### Certifications



ETL Sanitation



ETL US



5-15P

**WARNING:** This product can expose you to chemicals including Lead, which are known to the State of California to cause cancer, birth defects, or other reproductive harm. For more information, go to [www.p65warnings.ca.gov](http://www.p65warnings.ca.gov).





Enter Search Term(s)

# 1-800-SHAVED-ICE

Recommendations, Tips & More  
[Shaved Ice University](#)

- [Getting Started](#)
- [Machines](#)
- [Syrups](#)
- [Flavor Concentrates](#)
- [Supplies & Accessories](#)
- [Business Packages](#)

Home // Shaved Ice & Snow Cone Machines // Shaved Ice Machines // Block Ice Shavers // Swan SI-100E Block Ice Shaver

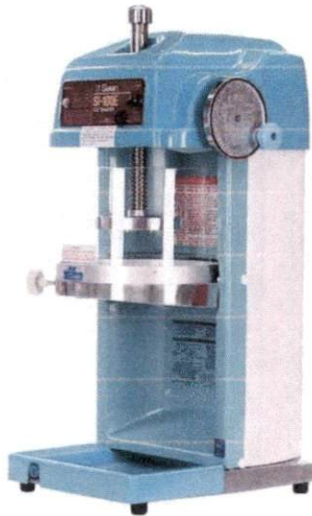

## Swan SI-100E Block Ice Shaver





Item #SI100EA  
★★★★★  
(2 reviews)

IN STOCK

WAS: \$2,350.00  
**NOW: \$1,995.00** (You Save 15%)

QTY:

### Additional Products We Recommend

Add?	Qty	
<input type="checkbox"/>	1	 Replacement Swan SI-100E Blade NOW: \$48.24
<input type="checkbox"/>	1	 Round Ice Mold NOW: \$4.24
<input type="checkbox"/>	1	 Aluminum Shaved Ice Drip Tray NOW: \$67.99
<input type="checkbox"/>	1	Warranty for Shaved Ice Machine  Choose Warranty Option Below NOW: \$99.00



[Add to Cart](#)

Finance as Low as...  
**\$55 / month**  
[Click to Apply Now!](#)

- [DESCRIPTION](#)
- [SPECS](#)
- [SHIPPING](#)

The Swan SI-100E is one of our best selling upright block ice shavers and is perfect for high-volume shaved ice business locations. It creates ultra-fine snow that absorbs flavoring quickly and can produce 4.6 pounds of shaved ice per minute.

This Swan shaved ice machine can hold a 7-pound square or round block of ice and features nearly 10 inches of clearance beneath the shaving disc for easy access with large cups. We recommend your ice be no larger than 6" wide by 6" tall if you are using a square block and no larger than 8" in diameter by 6" tall using a round block. At 1-800-Shaved-Ice, we carry the Swan block ice shaver in other models, including 220-volt (international) or 12-volt (battery operated). Each machine, including this model, includes a pre-installed blade plus an additional spare blade.

This machine has a 1/4 horsepower motor, is NSF approved and comes with a 1 year manufacturer's warranty. This Hawaiian style shaver is the signature Swan teal blue color which has always been an added plus for this machine.

The Swan SI-100E is incredibly durable with a metal frame masked with a high-quality plastic casing. The convenient drip tray with drain tube is perfect for redirecting and draining any ice overspray. However, we do recommend adding a larger drip pan with this model to ensure you have additional protection from overspray under your machine.

The machine weighs about 74 pounds and we recommend installing it on a sturdy and level surface. It does not include a hands-free foot pedal, however, we do suggest adding one to your shopping cart, you'll be glad you did. By doing so, you can easily use two hands to collect falling snow into your cup!

If you're unfamiliar with the Swan SI-100E or any of the other block ice shavers, we recommend checking out our Shaved Ice University to learn more and encourage you to watch the video we provided above. We suggest you thoroughly understand your machine before making a purchase and know the tempering process (allowing your ice to warm up before shaving). You may also refer to the user's manual below or call us any time with questions you may have.

### YOU MAY ALSO LIKE



**New Orleans Block Shaved Ice Machine**  
WAS: \$2,477.99  
**NOW: \$2,389.50**



**Hatsuyuki HF-500E Block Shaved Ice Machine**



## SPECS

- Machine Dimensions: 12" W x 15" D x 28" H
- Machine Weight: 68 lbs.
- Motor Size: 1/4 HP
- Electrical: 115V 4.5A 200W
- Ice Block Size: 6" x 6" x 6" (±)
- Shaving Capacity: 4.6 lbs. per minute
- Blade Life: 3,000 - 4,000 servings
- Shipping Weight: 74 lbs.
- Shipping Dimensions: 22" x 37" x 23"
- Manufacturers Warranty: 1 Year
- Certifications: NSF Certified
- Ice Consistency on our [Fluffiness Scale](#): 10

[Swan SI-100E Block Ice Shaver Owner's Manual](#)

## SHIPPING

 This item ships in 1-2 business days from our warehouse.

Transit times vary based on the shipping destination. This item is shipped via LTL Freight. Shipping costs are based on the weight and dimensions of the item along with distance from our warehouse to the destination. Someone 18 years or older must be available to sign for this machine upon delivery.

View our [shipping policy](#) for additional details or feel free to give us a call to discuss shipping options.

## Customer Reviews for Swan SI-100E Block Ice Shaver

★★★★★

(based on 2 reviews)

### The Super Shaver!!

★★★★★

By Nick from Boulder, CO | on 06/1/2017

Man I love this machine. I have been in business for about 10 years. I recently had to purchase another SWAN due to high volume. This is the only machine I will ever use. It gets the ice so fine and fluffy it's crazy. My customers love my product. It is also very easy to find parts for my older SWAN machine when I need them. SWAN The SUPER Shaver!!!!

### Smooth Operator

★★★★★

By Calvin Jones from USA | on 04/15/2016

The Swan SI-100E is the best Ice shaver I ever owned, well made and it will last. Mine is 15 years old and still shaving.

## RECENTLY VIEWED



Subscribe to our [E-Newsletter](#) to get deals, business tips, industry updates, and much more!

Enter Your Email

SIGN UP!

CALL US TODAY! 1-800-742-8334

321 GOLDSBORO STREET | NEWTON GROVE, NC 28366

## STORE INFO

[Home](#)  
[About Us](#)  
[Contact Us](#)  
[FAQ](#)  
[Shipping Info](#)  
[Returns](#)  
[Privacy Policy](#)

Need a recommendation or help knowing where to start?

## WHAT OUR CUSTOMERS SAY

*The flavors I have tried so far have been outstanding, can't wait to taste the others. Customer service was great and pleasant to deal with. I would definitely recommend [...]*  
-Sylvia, MN

[Read More Testimonials](#)

## CONNECT WITH US!

With Products Featured in...

AMERICA

WINDMILL

WSJ

competitor

SAVEUR

# ADC Series Ice Cream Dipping Cabinet

MODEL #360ADC4HC

REFRIGERATION  
**AVANTCO**

[www.AvantcoRefrigeration.com](http://www.AvantcoRefrigeration.com)

## ADC SERIES - DIPPING CABINETS

Great for displaying, merchandising and serving a delicious variety of ice cream flavors.

### CABINET CONSTRUCTION

Sturdy design features white powder-coated steel exterior and painted steel interior.

Foamed-in-place CFC- and HCFC-free polyurethane insulation enhances the structural integrity of the cabinet and promotes energy efficiency.

Locking glass lid provides constant product visibility to showcase a variety of ice cream flavors.

### REFRIGERATION SYSTEM

Environmentally-safe R290 refrigerant. Side-mounted condensing unit for side and rear ventilation. Cold wall design prevents cold air from escaping.

### STORAGE

Displays (4) 3-gallon tubs of ice cream at the perfect height for service. Additional storage for (2) 3-gallon tubs underneath.

### MODEL FEATURES

Pre-drilled holes for dipper well installation on back of the cabinet.

2" diameter casters provide mobility for easy cleaning and service.

Drain plug located on backside of unit.

## SPECIAL FEATURES

- Displays up to 4 ice cream tubs; space beneath display to store up to 2 back-up tubs
- White, curved-front design with painted steel construction
- Holds temperatures between -13 and 0°F; manual temperature control
- Environmentally-safe R290 refrigerant; manual defrost feature
- Perfect for ice cream shops, dessert bars, and cafeterias
- 115V, 1/4 hp

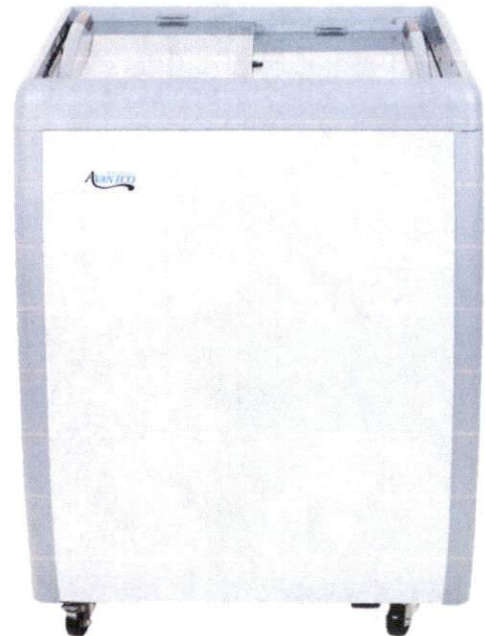

## WARRANTY

RESIDENTIAL: Avantco assumes no liability for parts or labor coverage for component failure, factory defect or any other damages for units installed in non-commercial foodservice or residential applications.



Replacement

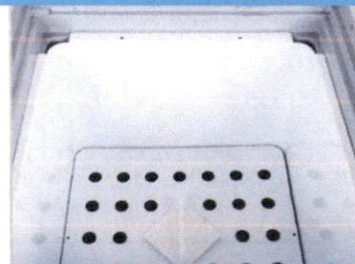
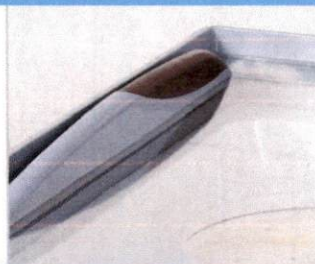

# ADC Series Ice Cream Dipping Cabinet

MODEL #360ADC4HC



[www.AvantcoRefrigeration.com](http://www.AvantcoRefrigeration.com)

## TECHNICAL DATA

### Dimensions

Exterior Dimensions	26 $\frac{1}{8}$ "W x 28 $\frac{1}{8}$ "D x 34 $\frac{1}{2}$ "H
Interior Dimensions	24 $\frac{3}{8}$ "W x 27"D x 20 $\frac{7}{8}$ "H
Net Volume	4.25 cu. ft.
Net Weight	124 lb.
Gross Weight	137 lb.
Packaging Dimensions	26 $\frac{1}{4}$ "W x 30"D x 37 $\frac{1}{2}$ "H
Tubs Displayed	4
Tubs Stored	2

### Construction

Exterior Material	Painted Steel
Interior Material	Painted Steel
Insulation Material	Foamed-In-Place Polyurethane
Tub Holder Material	Painted Steel

### Cooling

Temperature Range	(-13) - 0°F
Refrigerant	R290
Max. Ambient Temperature	90°F
Defrosting	Manual
Temperature Controller	Manual
Horsepower	1/4
BTU	682

### Electrical

Voltage	115
Amps	3
Hz	60
Phase	1
Plug Type	NEMA 5-15P
Electrical Cord Length	70"

## PLAN VIEW

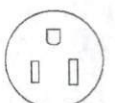
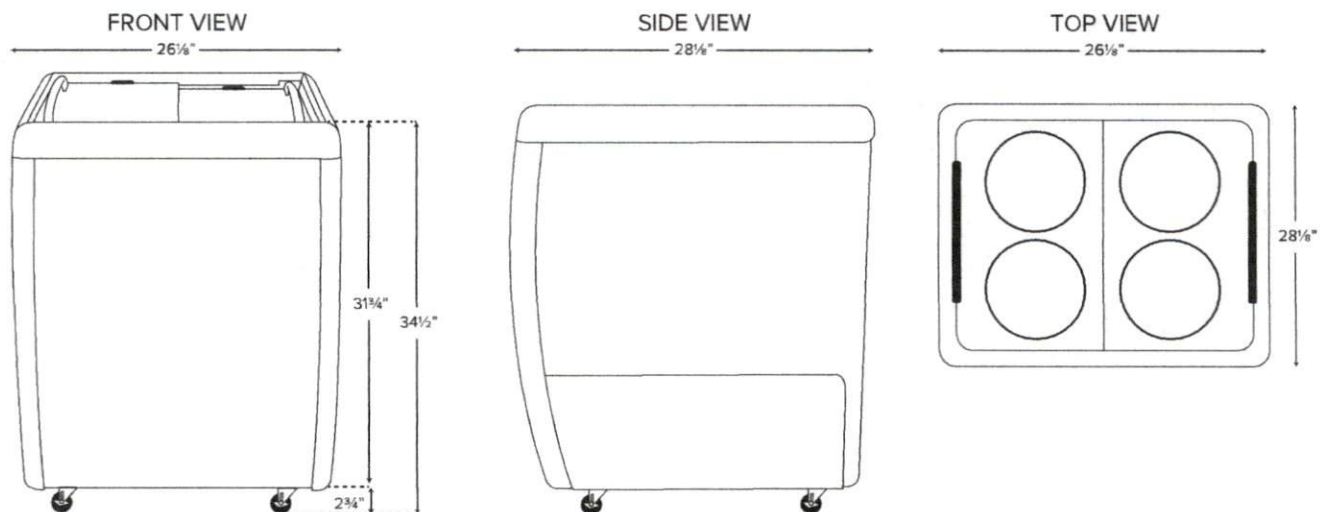

NEMA 5-15P

# STAINLESS STEEL THREE BOWL UNDERBAR HAND SINK WITH SWING FAUCET & DRAINBOARD

ITEM #: \_\_\_\_\_ QUANTITY: **1**

PROJECT: \_\_\_\_\_

APPROVAL: \_\_\_\_\_

DATE: \_\_\_\_\_

**REGENCY**  
Tables and Sinks

## FEATURES

- 18 gauge type 304 stainless steel top, bowl, and backsplash
- 20 gauge type 304 stainless steel apron
- Galvanized steel legs & sockets with plastic bullet feet
- (1) 11<sup>3</sup>/<sub>4</sub>" corrugated drainboard
- Holes punched on 4" centers accommodate included 10" swing spout, wall mounted faucet (600FW410LL)
- 3" high backsplash helps protect walls and contain splashes



## SPECIFICATIONS

ITEM	LENGTH	DEPTH	HEIGHT (Total)	HEIGHT (Work)	BOWL DEPTH	BOWL L to R	BOWL F to B	NUMBER OF DRAINBOARDS	SIDE	NET WEIGHT
600B3101413 RT	48"	18 <sup>3</sup> / <sub>4</sub> "	33"	30"	10"	10"	14"	1	Right	66.5 lb.



REGENCYTABLESANDSINKS.COM



**STAINLESS STEEL THREE BOWL  
UNDERBAR HAND SINK  
WITH SWING FAUCET & DRAINBOARD**

**REGENCY**  
Tables and Sinks

**TOP**

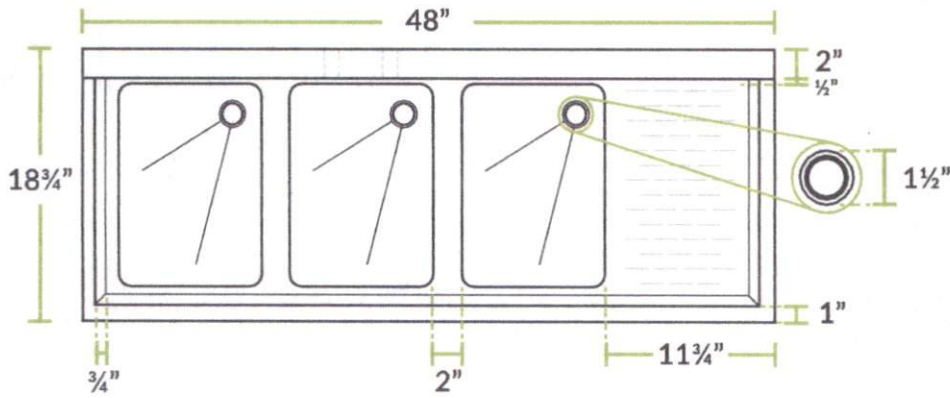

**FAUCET**

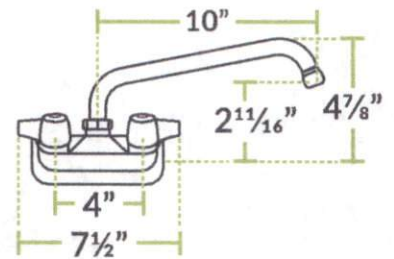

**FRONT**

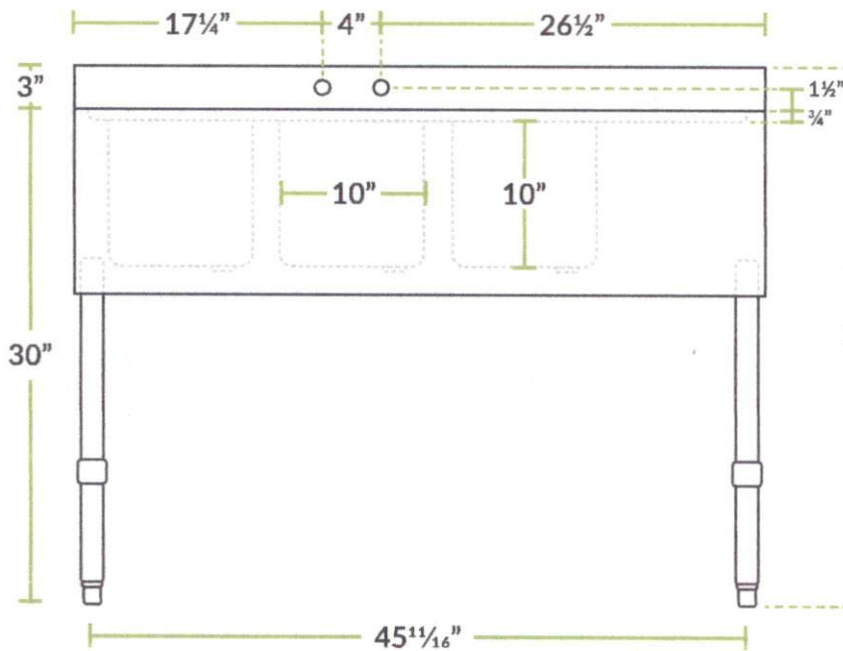

**SIDE**

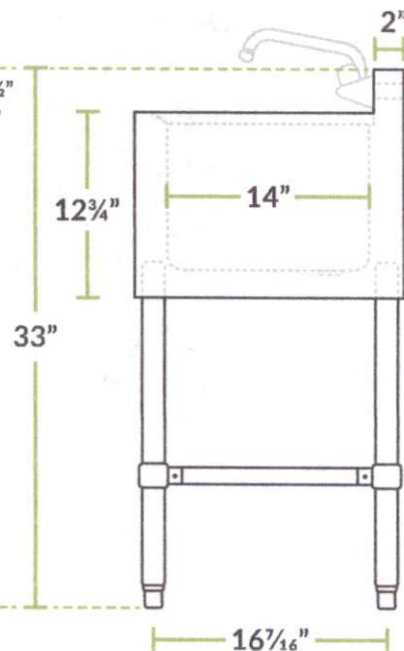

**STAINLESS STEEL WALL MOUNTED  
HAND SINKS**  
WITH GOOSENECK FAUCETS & SIDE SPLASHES

ITEM #: \_\_\_\_\_ QUANTITY: **J**  
PROJECT: \_\_\_\_\_  
APPROVAL: \_\_\_\_\_  
DATE: \_\_\_\_\_



**REGENCY**  
Tables and Sinks

**FEATURES**

- 20-gauge type 304 stainless steel
- Single bowl with 1½" IPS drain basket
- Easy-to-install 8" gooseneck faucet included
- Holes punched on 4" centers
- 8" backsplash
- 18-gauge type 304 stainless steel side splashes help prevent contamination



**SPECIFICATIONS**

ITEM	OVERALL (LEFT TO RIGHT)	OVERALL (FRONT TO BACK)	OVERALL (HEIGHT)	BOWL (LEFT TO RIGHT)	BOWL (FRONT TO BACK)	BOWL DEPTH	SIDE SPLASH
600HS12SP	12"	16"	10"	9"	9"	4"	Left & Right
600HS17SP	17"	15"	13½"	14"	10"	5½"	Left & Right

01/2019

STAINLESS STEEL WALL MOUNTED  
**HAND SINKS**  
 WITH GOOSENECK FAUCETS & SIDE SPLASHES



**600HSI2SP • 12" X 16"**

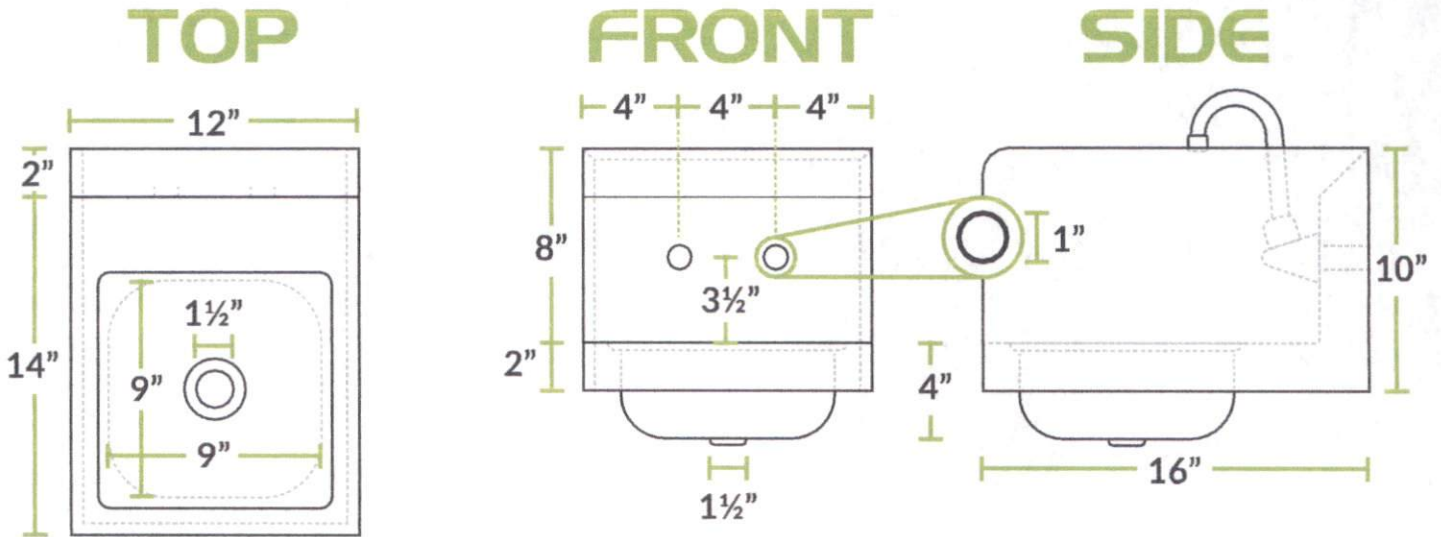

**600HSI7SP • 17" X 15"**

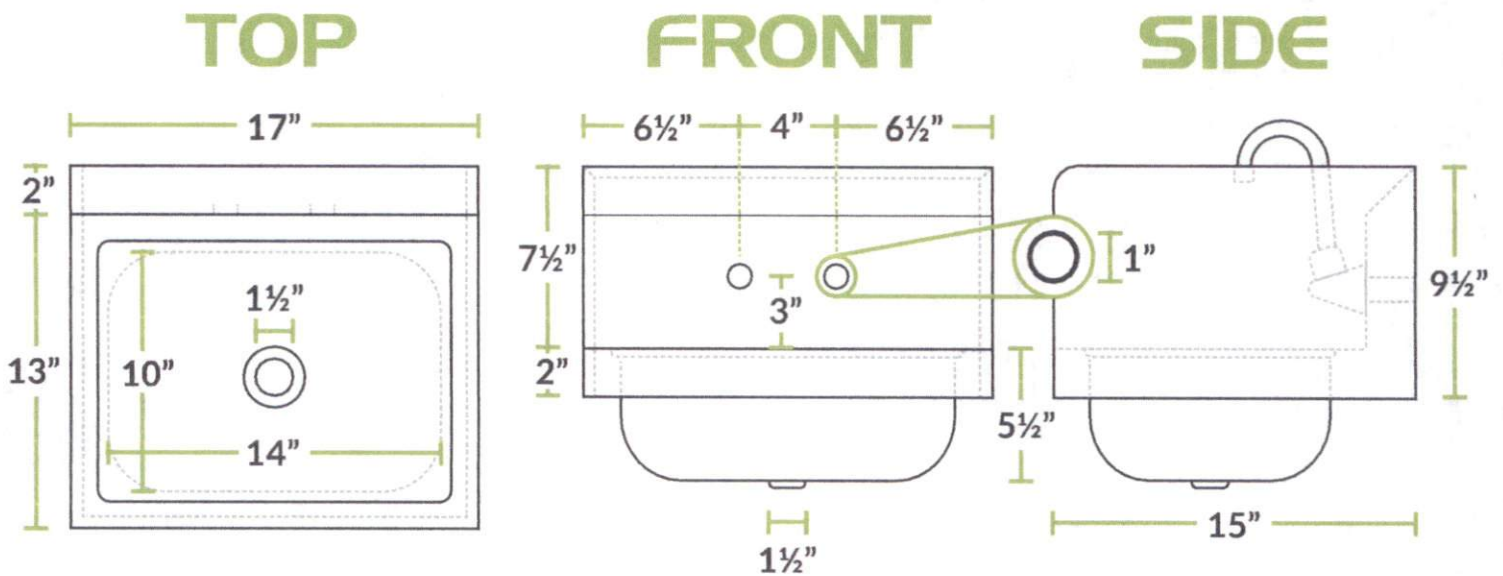



# WGen9500 Generator

★★★★★ 4.8 (16485) Write a review

- Up To 12 Hour Run Time with Remote and Electric Start
- Transfer and ST Switch Ready, Ideal for Home Backup Power
- 12500 Peak Watts and 9500 Rated Watts

MSRP **\$1,149.00**

### Where To Buy:

amazon

Walmart



ACME TOOLS

WENMART



Out of Stock

amazon.ca



Out of Stock

Out of Stock



## OVERVIEW

## SPECIFICATIONS

## MANUALS

## REVIEWS

The Westinghouse WGen9500 Portable Generator with 12,500 peak watts and 9,500 running watts is the perfect solution to your home back-up power needs. The heavy-duty 457cc 4-Stroke OHV Westinghouse Engine is constructed of a durable cast iron sleeve and runs for up to 12 hours on a 6.6 gallon (25 L) gasoline tank, keeping you powered through the day with built-in fuel gauge, automatic low oil shutdown, and GFCI outlets. Push-Button Electric Start makes starting this generator effortless while the remote start key fob offers the ease of distance ignition. Its intuitive control panel spotlights the Transfer Switch Ready L14-30R and larger 14-50R outlets to power all your major appliances like your air conditioner, refrigerator, and sump pump as well as lights or entertainment centers at the same time with a single cord hookup. VFT Data Center displays volt output, frequency, and lifetime hours to keep you up to date with real-time information and regular maintenance. Conveniently portable with an included set of heavy-duty never-flat wheels, foam grip handle, and lift bracket, it'll have your house, travel trailer, or job site powered in seconds. The WGen9500 is complete with a 3-Year Limited Warranty and Lifetime Technical Support backed by our nationwide customer service and support network.

- Perfect as a backup power source for larger homes or a dependable source of portable power
- 9,500 rated watts and 12,500 peak watts
- Runs for up to 12 hours on a 6.6 gal. fuel tank with built-in fuel gauge
- Powered by a heavy duty 457cc 4-Stroke OHV Westinghouse Engine constructed with a durable cast iron sleeve
- Push-Button Electric Start pairs with remote start key fob and is backed by emergency recoil start
- Weighing 208 lb. with as low as 74 dBA operating volume
- (2) GFCI 5-20R household duplex outlets, (1) Transfer Switch Ready L14-30R 120/240-Volt twist-lock, (1) 120/240V 14-50R receptacle, and (2) USB ports with rubber outlet covers
- VFT display gives you real time updates with the voltage output, frequency, and lifetime hours
- Safe and convenient with automatic low oil shutdown, automatic voltage regulation, and overload protection
- Hardened steel frame with foam grip handle and rugged never-flat wheels make portability easy
- All Westinghouse portable generators are functionally tested in the factory and may contain minimum residual oil and/or fuel odor

## CONTROL PANEL

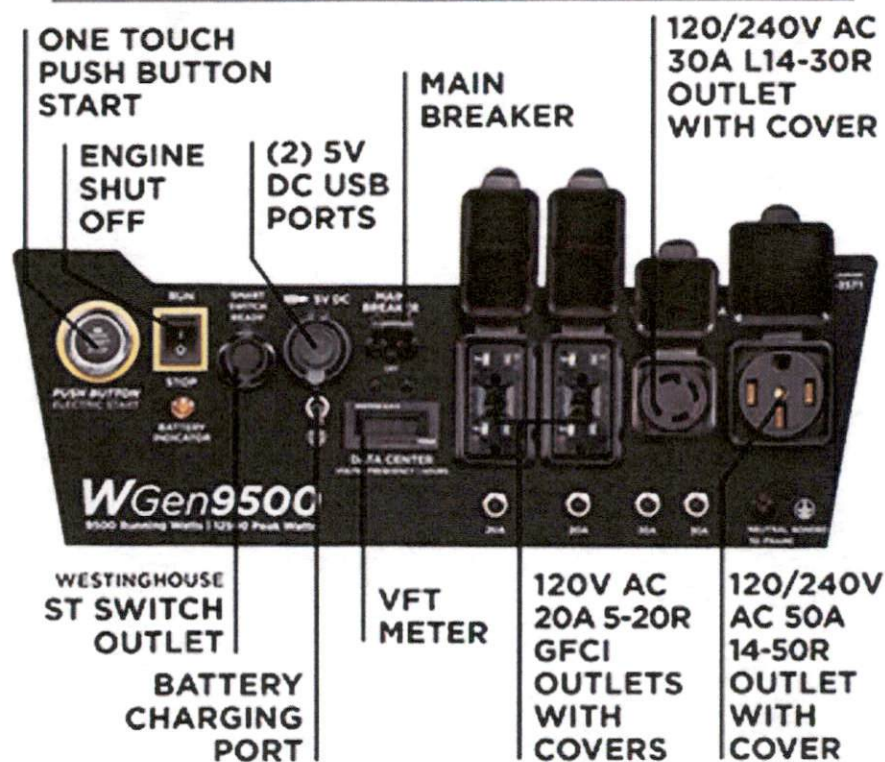

## WGen9500 Generator

OVERVIEW

SPECIFICATIONS

MANUALS

REVIEWS

WHERE TO BUY

Gasoline Peak Watts	12500	Gasoline Running Watts	9500
Gasoline Peak Amps	52A - 240V 104A - 120V	Gasoline Running Amps	39.5A - 240V 79A - 120V
AC Voltage	120/240V	AC Frequency	60 Hz
Outlets	2 Duplex 120V 5-20R 1 120/240V L14-30R 1 120/240V 14-50R 2 USB ports ST Switch	Total Harmonic Distortion	<23%
CFCI Outlets	Yes	Outlet Covers	Yes
Transfer Switch Ready	Yes	RV Ready	Yes
ST Switch Ready	Yes	Display Type	Digital Readout
Noise Level	74 dBA	Fuel Gauge	Yes
Fuel Tank Capacity	6.6 gal (25 L)	Gasoline Run Time @ 25%	12 hrs.
Gasoline Run Time @ 50%	8 hrs.	Starter Type	Electric, Remote, Recoil
Choke Type	Automatic	Engine Displacement	457cc
Engine Type	OHV 4-Stroke	Oil Capacity	37.2 oz. (1.1 qt.)
Engine Oil Type	10W30	Automatic Low Oil Shutdown	Yes
Carbon Monoxide (CO) Sensor	No	Overload Protection	Yes
CARB Compliant	Yes	Grounding System	Bonded Neutral
Battery Included	Yes	Included Accessories	Oil Bottle, Oil Funnel, Spark Plug Wrench, Remote, Battery Float Charger
Warranty (Residential)	3 Year Limited	Warranty (Commercial)	1 Year Limited
Product Dimensions	27.2L x 26.1W x 26.5H in.	Dry Unit Weight	208 lb. (94.3 kg)
Packaging Dimensions	31L x 21.5W x 25H in.	Shipping Weight	221 lb. (100.2 kg)
UPC	853544008199		



# 18" STAINLESS STEEL DROP-IN ICE BIN

**REGENCY**  
Tables and Sinks

M

600DIIB1824

## TOP

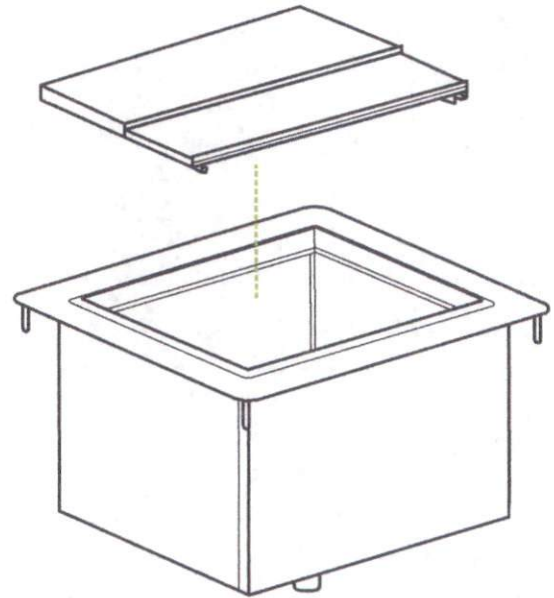
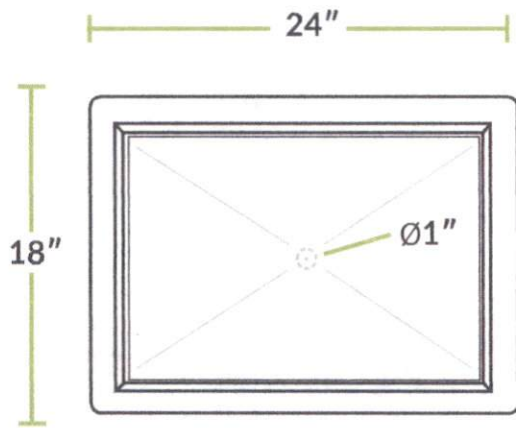

## FRONT

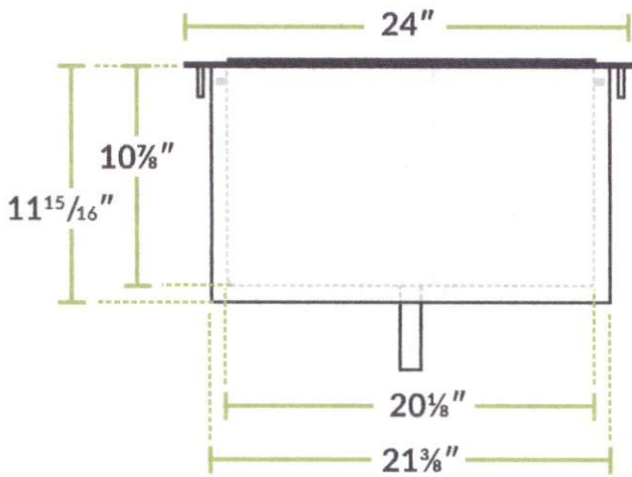

## SIDE

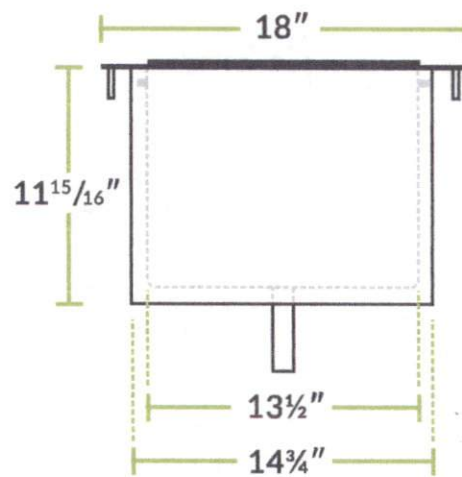

# 18" STAINLESS STEEL DROP-IN ICE BIN

ITEM #: \_\_\_\_\_ QUANTITY: \_\_\_\_\_

PROJECT: \_\_\_\_\_

APPROVAL: \_\_\_\_\_

DATE: \_\_\_\_\_

**REGENCY**  
Tables and Sinks

## FEATURES

- Made of 20 gauge, 304 stainless steel
- 1" NPT drain tubing
- Stainless steel sliding lid included
- Perfect for storing ice conveniently close at hand

**NSF**

## SPECIFICATIONS

ITEM	OVERALL (LEFT TO RIGHT)	OVERALL (FRONT TO BACK)	OVERALL (HEIGHT)	ICE BIN (LEFT TO RIGHT)	ICE BIN (FRONT TO BACK)	ICE BIN DEPTH	ICE BIN CAPACITY
600DIIB1824	24"	18"	11 <sup>15</sup> / <sub>16</sub> "	20 <sup>7</sup> / <sub>8</sub> "	13 <sup>1</sup> / <sub>2</sub> "	10 <sup>7</sup> / <sub>8</sub> "	50 lb.
600DIIB1830	30"	18"	11 <sup>15</sup> / <sub>16</sub> "	26 <sup>7</sup> / <sub>8</sub> "	13 <sup>1</sup> / <sub>2</sub> "	10 <sup>7</sup> / <sub>8</sub> "	62 lb.
600DIIB1836	36"	18"	11 <sup>15</sup> / <sub>16</sub> "	32 <sup>7</sup> / <sub>8</sub> "	13 <sup>1</sup> / <sub>2</sub> "	10 <sup>7</sup> / <sub>8</sub> "	75 lb.

09/2019

REGENCYTABLESANDSINKS.COM



### DHC Classic Technical Specifications

N

#### Technical Data



Certified to ANSI/UL Std. 499  
Conforms to CSA Std. E335-1/3E  
& E60335-2-35



Tested and certified by WQA  
against NSF/ANSI 372 for lead  
free compliance.

ISO 9001  
CERTIFIED

Model	DHC 3-1 Classic	DHC 3-2 Classic	DHC 4-2 Classic	DHC 4-3 Classic	DHC 5-2 Classic	DHC 6-2 Classic	DHC 6-3 Classic	DHC 8-2 Classic	DHC 9-3 Classic	DHC 10-2 Classic
Item no.	202646	202647	202648	202649	202650	202651	202652	202653	202654	202655
Phase - 50/60 Hz	1									
Voltage	120 V	240 V 208 V	240 V 208 V	277 V	240 V 208 V	240 V 208 V	277 V	240 V 208 V	277 V	240 V 208 V
Wattage	3.0 kW	3.3 kW 2.5 kW	3.8 kW 2.9 kW	4.5 kW	4.8 kW 3.6 kW	6.0 kW 4.5 kW	6.0 kW	7.2 kW 5.4 kW	9.0 kW	9.6 kW 7.2 kW
Amperage	25 A	14 A 12 A	16 A 14 A	17 A	20 A 18 A	25 A 22 A	21.7 A	30 A 26 A	32.5 A	40 A 35 A
Min. recommended circuit breaker size <sup>1</sup>	25 A	15 A 15 A	20 A 15 A	20 A	20 A 20 A	25 A 25 A	25 A	30 A 30 A	35 A	40 A 35 A
Min. recommended wire size <sup>2</sup>	10/2 AWG	14/2 AWG	12/2 AWG 14/2 AWG	12/2 AWG	12/2 AWG	10/2 AWG	10/2 AWG	10/2 AWG	8/2 AWG	8/2 AWG
Minimum water flow to activate unit	0.32 gpm (1.2 l/min)	0.32 gpm (1.2 l/min)	0.43 gpm (1.6 l/min)	0.43 gpm (1.6 l/min)	0.43 gpm (1.6 l/min)	0.48 gpm (1.8 l/min)	0.48 gpm (1.6 l/min)	0.69 gpm (2.6 l/min)	0.8 gpm (3.0 l/min)	0.8 gpm (3.0 l/min)
Weight	5.5 lb (2.5 kg)	4.6 lb (2.1 kg)	4.6 lb (2.1 kg)	4.6 lb (2.1 kg)	4.6 lb (2.1 kg)	5.5 lb (2.5 kg)	5.5 lb (2.5 kg)	5.5 lb (2.5 kg)	5.5 lb (2.5 kg)	5.5 lb (2.5 kg)
Dimensions	Width 7 <sup>15</sup> / <sub>16</sub> " (20.2 cm) x Height 14 <sup>3</sup> / <sub>16</sub> " (36.0 cm) x Depth 3 <sup>1</sup> / <sub>8</sub> " (9.8 cm)									
Nominal water volume	0.13 gal (0.5 l)									
Max. permissible inlet temperature	86 °F (30 °C)									
Minimum pressure	30 psi (2 bar)									
Working pressure	150 psi (10 bar)									
Tested to pressure	300 psi (20 bar)									
Water connections <sup>3</sup>	1/2" NPT									

DHC 3-1, 3-2, 4-2 Classic ship with a 0.5 gpm (1.9 l/min) pressure compensating flow-reducer/aerator that must be installed.

<sup>1</sup> This is our recommendation for overcurrent protection sized at 100% of load (DP for 240/208/277 V & SP for 120 V models). Check local codes for compliance if necessary. Tankless water heaters are considered a non-continuous load.

<sup>2</sup> Copper must be used. Conductors should be sized to maintain a voltage drop of less than 3% under load.

<sup>3</sup> Suitable for supply with cold water only.

Scroll for temp. rise charts. ↓

rev. 9.2020 Due to our continuous process of engineering and technological advancement, specifications may change without notice.

STIEBEL ELTRON

Simply the Best

W

Technical Data

[Redacted header information]

[Redacted technical specifications and data]

[Redacted technical specifications and data]

Vertical text on the left margin, possibly a reference or model number.

## DHC Classic Technical Specifications

Temperature Rise vs. Flow Rate at Maximum Rated Voltage

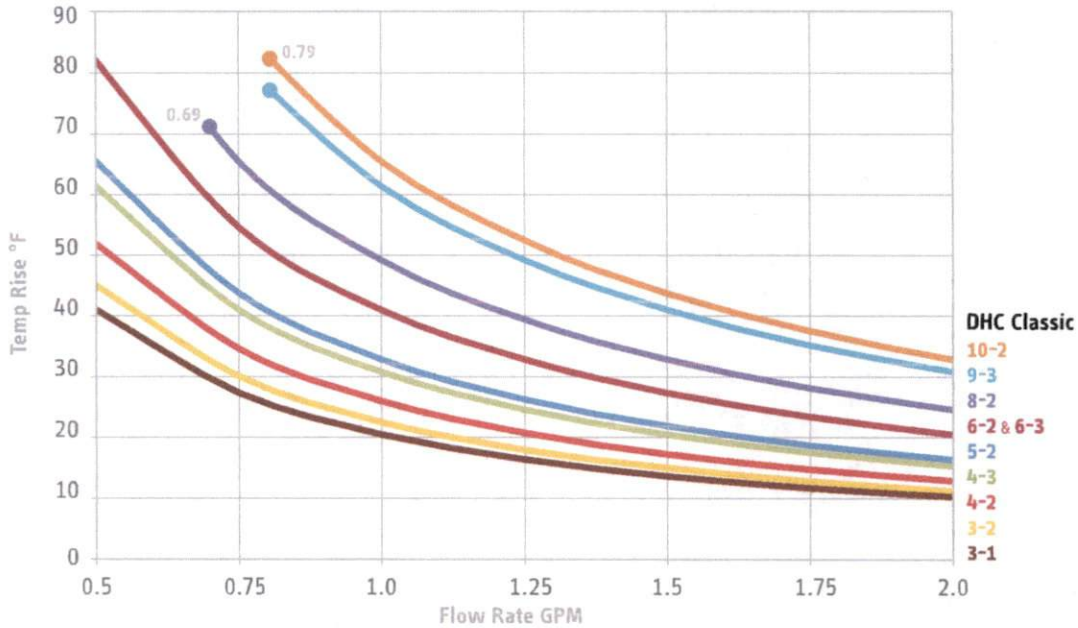

Temperature Rise vs. Flow Rate at 208 V

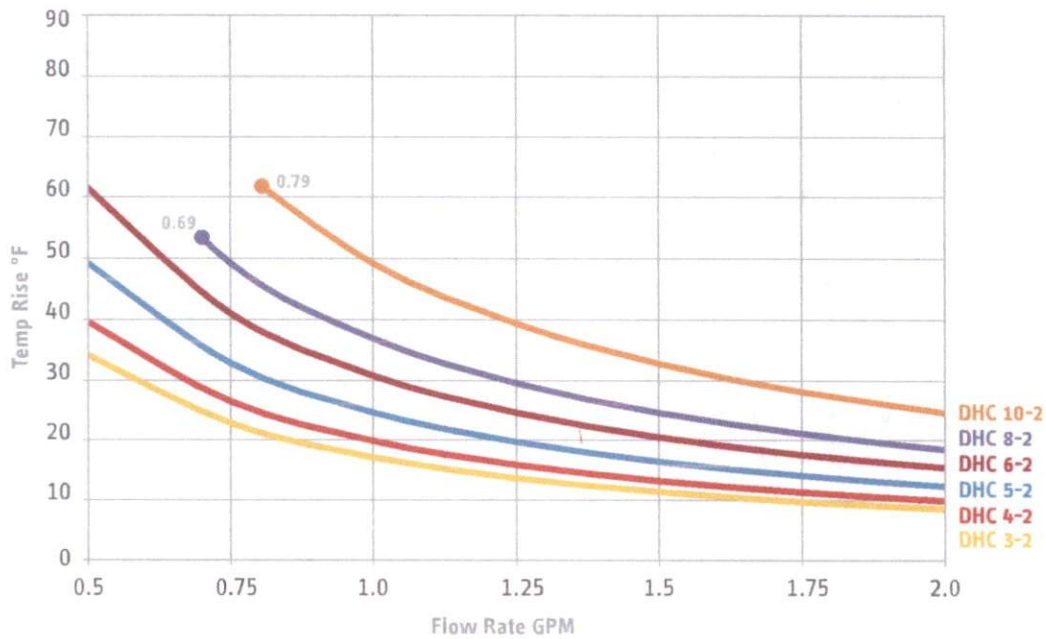

rev. 9.2020 Due to our continuous process of engineering and technological advancement, specifications may change without notice.



Item#: \_\_\_\_\_ Quantity: \_\_\_\_\_  
 Project: \_\_\_\_\_ Approval: \_\_\_\_\_ Date: \_\_\_\_\_



# 18-Gauge Stainless Steel Work Tables

## Features

- Smooth type 430 stainless steel work surface makes cleaning a breeze
- Galvanized steel legs, undershelf, and hat channels provide unparalleled stability
- Adjustable bullet feet ensure leveling on uneven surfaces
- Simple assembly and installation requires little effort



## Specifications



ITEM	LENGTH	WIDTH	WORK HEIGHT	UNDERSHELF DIMENSIONS	TOP SHELF CAPACITY	UNDERSHELF CAPACITY	WEIGHT
522ETSG2424	24"	24"	34"	19¼" x 18"	485 lb.	297 lb.	28.4 lb.
522ETSG2430	30"	24"	34"	25¼" x 18"	529 lb.	330 lb.	29.7 lb.
522ETSG2436	36"	24"	34"	31¼" x 18"	573 lb.	330 lb.	36.3 lb.
522ETSG2448	48"	24"	34"	43¼" x 18"	606 lb.	363 lb.	44.4 lb.
522ETSG2460	60"	24"	34"	55¼" x 18"	650 lb.	396 lb.	52.4 lb.
522ETSG2472	72"	24"	34"	67¼" x 18"	705 lb.	396 lb.	61.6 lb.
522ETSG2496	96"	24"	34"	91¼" x 18"	1102 lb.	462 lb.	85.4 lb.
522ETSG3030	30"	30"	34"	25¼" x 24"	551 lb.	330 lb.	36.7 lb.
522ETSG3036	36"	30"	34"	31¼" x 24"	595 lb.	363 lb.	40.7 lb.
522ETSG3048	48"	30"	34"	43¼" x 24"	639 lb.	363 lb.	51.5 lb.
522ETSG3060	60"	30"	34"	55¼" x 24"	679 lb.	396 lb.	62.0 lb.
522ETSG3072	72"	30"	34"	67¼" x 24"	750 lb.	396 lb.	72.6 lb.
522ETSG3096	96"	30"	34"	91¼" x 24"	1157 lb.	484 lb.	99 lb.

NOTE: 96" Work Tables Feature (6) Six Legs for Added Stability

N

Stalton

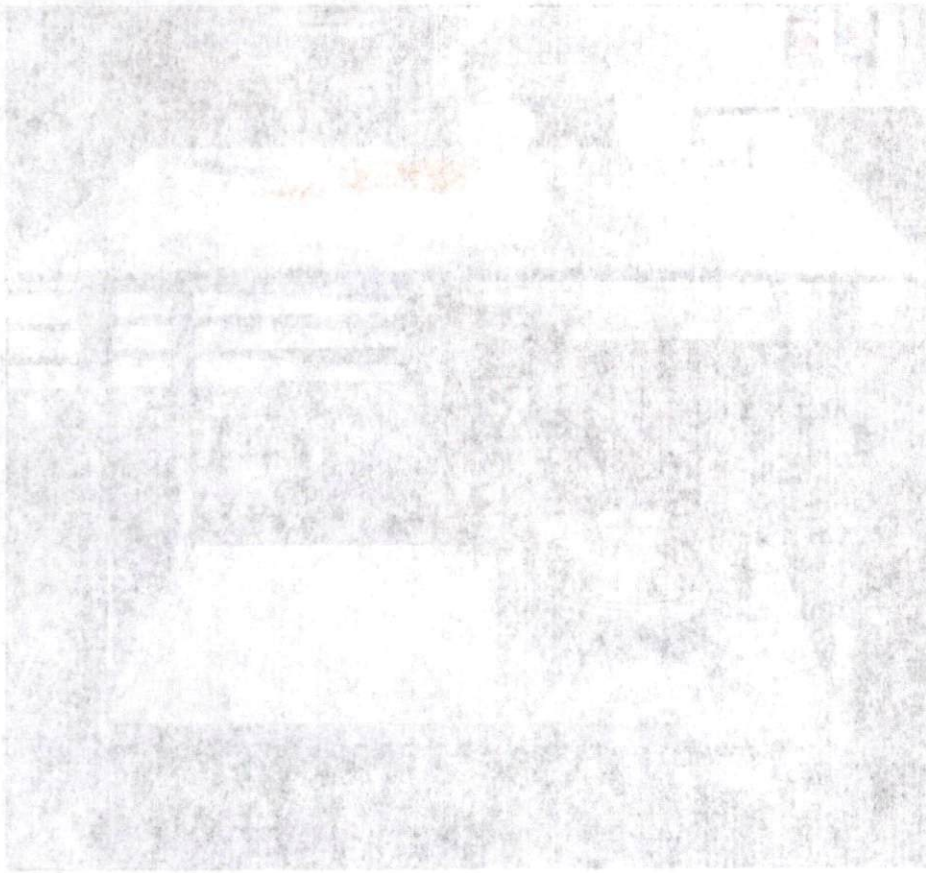

Work Table

STALTON

Adjustable height  
Stainless steel  
Work Table

Specifications

Model	Height	Width	Depth	Weight	Material	Finish
ST-100	30"	48"	30"	150 lbs	Stainless Steel	Brushed
ST-150	32"	54"	36"	180 lbs	Stainless Steel	Brushed
ST-200	34"	60"	42"	220 lbs	Stainless Steel	Brushed
ST-250	36"	66"	48"	260 lbs	Stainless Steel	Brushed
ST-300	38"	72"	54"	300 lbs	Stainless Steel	Brushed
ST-350	40"	78"	60"	340 lbs	Stainless Steel	Brushed
ST-400	42"	84"	66"	380 lbs	Stainless Steel	Brushed
ST-450	44"	90"	72"	420 lbs	Stainless Steel	Brushed
ST-500	46"	96"	78"	460 lbs	Stainless Steel	Brushed
ST-550	48"	102"	84"	500 lbs	Stainless Steel	Brushed
ST-600	50"	108"	90"	540 lbs	Stainless Steel	Brushed



Item#: \_\_\_\_\_ Quantity: \_\_\_\_\_  
Project: \_\_\_\_\_ Approval: \_\_\_\_\_ Date: \_\_\_\_\_

# TOP

LENGTH

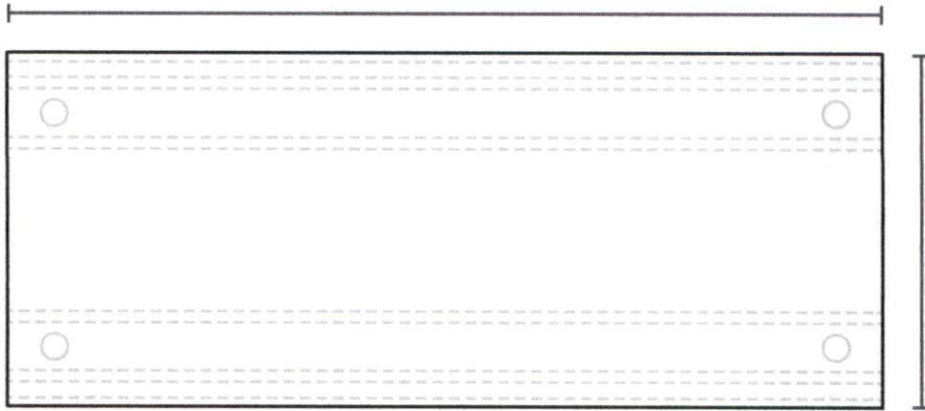

# FRONT

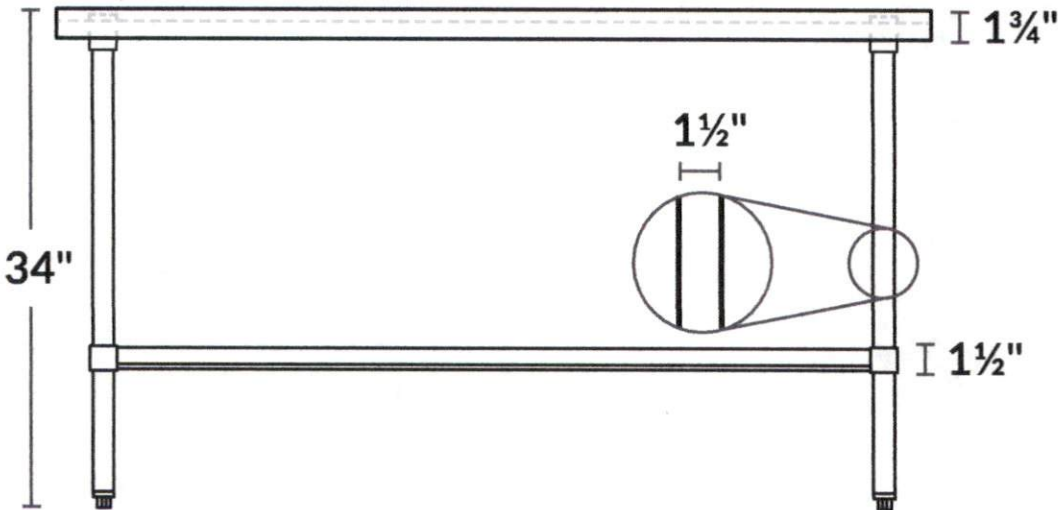

# SIDE

